

**25HCC5
Performance™ 15 Heat Pump
with Puron® Refrigerant
1–1/2 To 5 Nominal Tons**



Product Data



Performance
SERIES

Carrier's heat pumps with Puron® refrigerant provide a collection of features unmatched by any other family of equipment. The 25HCC5 has been designed utilizing Carrier's Puron refrigerant. The environmentally sound refrigerant allows consumers to make a responsible decision in the protection of the earth's ozone layer. This product has been designed and manufactured to meet Energy Star® criteria for energy efficiency when matched with appropriate coil components. Refer to the combination ratings in the Product Data for system combinations that meet Energy Star® guidelines.

NOTE: Ratings contained in this document are subject to change at any time. Always refer to the AHRI directory (www.ahridirectory.org) for the most up-to-date ratings information.

INDUSTRY LEADING FEATURES / BENEFITS

Efficiency

- 13.0 - 15.3 SEER/ 11.0 - 13.0 EER/ 7.7 - 9.0 HSPF (Nominal)
- Microtube Technology™ refrigeration system
- Indoor air quality accessories available

Sound

- Sound level as low as 68 dBA

Comfort

- System supports Thermidistat™ or standard thermostat controls

Reliability

- Puron® refrigerant - environmentally sound, won't deplete the ozone layer and low lifetime service cost.
- Front-seating service valves
- Scroll compressor
- Internal pressure relief valve
- Internal thermal overload
- High pressure switch
- Loss of charge switch
- Filter drier
- Balanced refrigeration system for maximum reliability

Durability

WeatherArmor Ultra™ protection package:

- Solid, durable sheet metal construction
- Steel louver coil guard
- Baked-on, complete coverage, powder paint

Applications

- Long-line - up to 250 feet (76.20 m) total equivalent length, up to 200 feet (60.96 m) condenser above evaporator, or up to 80 ft. (24.38 m) evaporator above condenser (See Longline Guide for more information.)
- Low ambient (down to -20°F/-28.9°C) with accessory kit

MODEL NUMBER NOMENCLATURE

1	2	3	4	5	6	7	8	9	10	11	12	13
N	N	A	A	A/N	N	N	N	A/N	A/N	A/N	N	N
2	5	H	C	C	5	3	6	A	0	0	3	1
Product Series	Product Family	Tier	Major Series	SEER	Cooling Capacity	Variations	Open	Open	Voltage	Minor Series		
25 = HP	H = RES HP	C=Performance	C = Puron	5=15 SEER		A = Standard	0=Not Defined	0=Not Defined	3=208/230-1	0, 1, 2...		



Use of the AHRI Certified TM Mark indicates a manufacturer's participation in the program. For verification of certification for individual products, go to www.ahridirectory.org.



ISO 9001
QMI-SAI Global



This product has been designed and manufactured to meet Energy Star® criteria for energy efficiency when matched with appropriate coil components. However, proper refrigerant charge and proper air flow are critical to achieve rated capacity and efficiency. Installation of this product should follow all manufacturing refrigerant charging and air flow instructions. **Failure to confirm proper charge and air flow may reduce energy efficiency and shorten equipment life.**

STANDARD FEATURES

Feature	18	24	30	36	42	48	60
Puron Refrigerant	X	X	X	X	X	X	X
Maximum SEER Rating*	14.5	15.3	15.0	15.0	15.3	15.0	15.0
Scroll Compressor	X	X	X	X	X	X	X
Louvered Coil Guard	X	X	X	X	X	X	X
Field Installed Filter Drier	X	X	X	X	X	X	X
Front Seating Service Valves	X	X	X	X	X	X	X
Internal Pressure Relief Valve	X	X	X	X	X	X	X
Internal Thermal Overload	X	X	X	X	X	X	X
Long Line capability	X	X	X	X	X	X	X
Low Ambient capability with Kit	X	X	X	X	X	X	X
Suction Line Accumulator	X	X	X	X	X	X	X
High Pressure Switch	X	X	X	X	X	X	X
Loss of Charge Switch	X	X	X	X	X	X	X

* Based on tested combination ratings
X = Standard

PHYSICAL DATA

UNIT SIZE SERIES	18	24	30	36	42	48	60
Operating Weight lb (kg)	169	200	196	215	245	260	294
Shipping Weight lb (kg)	207	233	242	257	290	303	345
Compressor Type	Scroll						
REFRIGERANT	R-410A						
Control	TXV (R-410A Hard Shutoff)						
Charge (lb)	5.6	7.6	7.0	7.4	8.9	9.6	12.5
COND FAN	Propeller Type, Direct Drive						
Air Discharge	Vertical						
Air Qty (CFM)	2233	3223	3223	3810	3810	4046	4046
Motor HP	1/12	1/12	1/12	1/5	1/5	1/4	1/4
Motor RPM	800	800	800	800	800	800	800
COND COIL							
Face Area (Sq ft)	15.09	20.12	20.12	22.63	17.60	20.12	25.15
Fins per In.	20	20	20	20	20	20	20
Rows	1	1	1	1	2	2	2
Circuits	4	5	5	6	7	7	9
VALVE CONNECT. (In. ID)							
Vapor	5/8	5/8	3/4	3/4	7/8	7/8	7/8
Liquid	3/8						
REFRIGERANT TUBES (In. OD)							
Rated Vapor*	5/8	5/8	3/4	3/4	7/8	7/8	1-1/8
Max Liquid Line	3/8"						

*Units are rated with 25 ft (7.6 m) of lineset length. See *Vapor Line Sizing and Cooling Capacity Loss* table when using other sizes and lengths of lineset.

Note: See unit Installation Instruction for proper installation.

25HCC5

VAPOR LINE SIZING AND COOLING CAPACITY LOSS

Acceptable vapor line diameters provide adequate oil return to the compressor while avoiding excessive capacity loss. The suction line diameters shown in the chart below are acceptable for HP systems with Puron refrigerant:

VAPOR LINE SIZING AND COOLING CAPACITY LOSSES - PURON® REFRIGERANT 1- STAGE HEAT PUMP APPLICATIONS

Unit Nominal Size (Btuh)	Maximum Liquid Line Diameters (In. OD)	Vapor Line Diameters (In.) OD	Cooling Capacity Loss (%) Total Equivalent Line Length ft. (m)								
			Standard Application		Long Line Application Requires Accessories						
			26-50 (7.9-15.2)	51-80 (15.5-24.4)	81-100 (24.7-30.5)	101-125 (30.8-38.1)	126-150 (38.4-45.7)	151-175 (46.0-50.3)	176-200 (53.6-60.0)	201-225 (61.3-68.6)	226-250 (68.9-76.2)
18,000 1-Stage HP with Puron	3/8	1/2	1	2	3	4	6	7	8	9	10
		5/8	0	0	1	1	1	2	2	3	3
24,000 1-Stage HP with Puron	3/8	5/8	0	1	1	2	3	3	4	4	5
		3/4	0	0	0	0	1	1	1	1	1
30,000 1-Stage HP with Puron	3/8	5/8	1	2	3	3	4	5	6	7	8
		3/4	0	0	1	1	1	2	2	2	3
		7/8	0	0	0	0	1	1	1	1	1
36,000 1-Stage HP with Puron	3/8	5/8	1	2	4	5	6	7	9	10	11
		3/4	0	0	1	1	2	2	3	3	4
		7/8	0	0	0	0	1	1	1	1	2
42,000 1-Stage HP with Puron	3/8	3/4	0	1	2	2	3	4	4	5	6
		7/8	0	0	1	1	1	2	2	2	3
48,000 1-Stage HP with Puron	3/8	3/4	0	1	2	3	4	5	5	6	7
		7/8	0	0	1	1	2	2	2	3	3
60,000+ 1-Stage HP with Puron	3/8	3/4	1	2	4	5	6	7	9	10	11
		7/8	0	1	2	2	3	4	4	5	5
		1-1/8	0	0	0	1	1	1	1	1	1

Standard Length = 80 ft. (24.4 m) or less total equivalent length

Applications in this area are long line. Accessories are required as shown recommended on Long Line Application Guidelines

Applications in this area may have height restrictions that limit allowable total equivalent length, when outdoor unit is below indoor unit. See Long Line Application Guidelines

REFRIGERANT PIPING LENGTH LIMITATIONS

Maximum Line Lengths:

The maximum allowable total equivalent length for heat pumps varies depending on the vertical separation. See the tables below for allowable lengths depending on whether the outdoor unit is on the same level, above or below the indoor unit.

MAXIMUM LINE LENGTHS FOR HEAT PUMP APPLICATIONS

	MAXIMUM ACTUAL LENGTH ft (m)	MAXIMUM EQUIVALENT LENGTH† ft (m)	MAXIMUM VERTICAL SEPARATION ft (m)
Units on equal level	200 (61)	250 (76.2)	N/A
Outdoor unit ABOVE indoor unit	200 (61)	250 (76.2)	200 (61)
Outdoor unit BELOW indoor unit	See Table 'Maximum Total Equivalent Length: Outdoor Unit BELOW Indoor Unit'		

† Total equivalent length accounts for losses due to elbows or fitting. See the Long Line Guideline for details.

MAXIMUM TOTAL EQUIVALENT LENGTH† - OUTDOOR UNIT BELOW INDOOR UNIT

Size	Liquid Line Diameter w/ TXV	HP with Puron® Refrigerant – Maximum Total Equivalent Length† Vertical Separation ft (m) Outdoor unit BELOW indoor unit;						
		0–20 (0 – 6.1)	21–30 (6.4 – 9.1)	31–40 (9.4 – 12.2)	41–50 (12.5 – 15.2)	51–60 (15.5 – 18.3)	61–70 (18.6 – 21.3)	71–80 (21.6 – 24.4)
18000 HP with Puron	3/8	250*	250*	250*	250*	250*	250*	250*
24000 HP with Puron	3/8	250*	250*	250*	250*	250*	250*	250*
30000 HP with Puron	3/8	250*	250*	250*	250*	250*	250*	250*
36000 HP with Puron	3/8	250*	250*	250*	250*	250*	250*	250*
42000 HP with Puron	3/8	250*	250*	250*	250*	250*	250*	150
48000 HP with Puron	3/8	250*	250*	250*	250*	230	160	--
60000 HP with Puron	3/8	250*	225*	190	150	110	--	--

* Maximum actual length not to exceed 200 ft (61 m)

† Total equivalent length accounts for losses due to elbows or fitting. See the Long Line Guideline for details.

-- = outside acceptable range

LONG LINE APPLICATIONS

An application is considered Long Line when the refrigerant level in the system requires the use of accessories to maintain acceptable refrigerant management for systems reliability. Defining a system as long line depends on the liquid line diameter, actual length of the tubing, and vertical separation between the indoor and outdoor units.

For Heat Pump systems, the chart below shows when an application is considered Long Line. Beyond these lengths, long line accessories are required:

HP WITH PURON® REFRIGERANT LONG LINE DESCRIPTION FT (M) BEYOND THESE LENGTHS, LONG LINE ACCESSORIES ARE REQUIRED

Liquid Line Size	Units On Same Level	Outdoor Below Indoor	Outdoor Above Indoor
3/8	80 (24.4)	20 (6.1) vertical or 80 (24.4) total	80 (24.4)

Note: See Long Line Guideline for details

ACCESSORIES

ORDER NUMBER	DESCRIPTION	18-30	24-30	30-30	36-30	42-30	48-30	60-30
KAACH1701AAA	CRANKCASE HTR	X	X	X				
KAACH1401AAA	CRANKCASE HTR				X			
KAACH1601AAA	CRANKCASE HTR					X		
KAACH1201AAA	CRANKCASE HTR						X	
Standard	CRANKCASE HTR							S
KSACY0101AAA	CYCLE PROTECTOR	X	X	X	X	X	X	X
KAFT0101AAA	FREEZE THERMOSTAT	X	X	X	X	X	X	X
KSAHS1701AAA	HARD START (CAP/RELAY)	X	X	X	X	X	X	X
KHAIR0101AAA	ISOLATION RELAY	X	X	X	X	X	X	X
KSALA0301410	LOW AMBIENT PSW	X	X	X	X	X	X	X
HC32GE229	MOTOR FAN BALL BEARING	X	X	X				
HC38GE228	MOTOR FAN BALL BEARING				X	X		
HC40GE228	MOTOR FAN BALL BEARING						X	X
KSALA0601AAA	MOTORMASTER 230V	X	X	X	X	X	X	X
KHAOT0201SEC	OUTDOOR THERMOSTAT	X	X	X	X	X	X	X
KHAOT0301FST	OUTDOOR THERMOSTAT	X	X	X	X	X	X	X
KHASS0606MPK*	HEAT PUMP SNOW RACK	X	X	X	X	X	X	X
KHALS0401LLS	SOLENOID VALVE	X	X	X	X	X	X	X
KAACS0201PTC	START ASSIST PTC	X	X	X	X	X	X	X
KSASF0101AAA	SUPPORT FEET	X	X	X	X	X	X	X
KAATD0101TDR	TIME DELAY	X	X	X	X	X	X	X
KSATX0201PUR	TXV PURON HSO	X	X	X				
KSATX0301PUR	TXV PURON HSO				X	X		
KSATX0401PUR	TXV PURON HSO						X	
KSATX0501PUR	TXV PURON HSO							X

x = Accessory S = Standard

* Order through RCD – Totaline, part number KHASS0606MPK (qty 6).

25HCC5

ACCESSORY THERMOSTATS

PART NUMBER	PROGRAM	GAS	ELECTRIC	HEAT PUMP	HYBRID HEAT	HEAT	COOL
Performance							
TP-PRH01-A	7-Day	√	√	√	√	3	2
TP-PHP01	7-Day		√	√		3	2
TP-NRH01-A	NP	√	√	√	√	3	2
TP-NHP01	NP		√	√		3	2

THERMOSTAT ACCESSORIES		
PART NUMBER	BRIEF DESCRIPTION	THERMOSTATS USED WITH
SYSTXCCRRS01	Indoor Remote Room Temperature Sensor	All TP- thermostats
TP-EXP01-A	ExP Computer Programming Accessory	TP-P thermostats
TSTATXXCNV10*	Thermostat Conversion Kit (4 to 5 wire) – 10 pack	All Carrier branded thermostats
TX-LBP01	Large Decorative Backplate	TP-Pxx, TP-Nxx, TC-Pxx
TSTATXXSEN01-B†	Outdoor Air Temperature Sensor	All TP- thermostats

* Thermostat conversion kit is a 24-vac accessory that can turn a 4-wire thermostat application into a 5-wire application. This kit can also be used to replace a broken thermostat wire, or add an extra wire when needed.

† Outdoor temperature sensor is an accessory for all Carrier electronic thermostats, except the non-programmable air conditioner version and builder;s thermostats. It allows the temperature at a remote location (outdoors) to be displayed on the thermostat. The outdoor air temperature sensor must be used with the HybridHeat™ (dual fuel) thermostat. The outdoor air temperature sensor is included with the Thermidistat Control and HybridHeat™ (dual fuel) thermostat.

ACCESSORY USAGE GUIDELINE

Accessory	REQUIRED FOR LOW – AMBIENT COOLING APPLICATIONS (Below 55°F / 12.8°C)	REQUIRED FOR LONG LINE APPLICATIONS*	REQUIRED FOR SEA COAST APPLICATIONS (Within 2 miles / 3.22 km)
Accumulator	Standard	Standard	Standard
Ball Bearing Fan Motor	Yes†	No	No
Compressor Start Assist Capacitor and Relay	Yes	Yes	No
Crankcase Heater	Yes	Yes	No
Evaporator Freeze Thermostat	Yes	No	No
Hard Shutoff TXV	Yes	Yes	Yes
Isolation Relay	Yes	No	No
Liquid Line Solenoid Valve	No	See Long-Line Application Guideline	No
Motor Master® Control or Low Ambient Switch	Yes	No	No
Support Feet	Recommended	No	Recommended

* For tubing line sets between 80 and 200 ft. (24.38 and 60.96 m) and/or 20 ft. (6.09 m) vertical differential, refer to Residential Piping and Longline Guideline.

† Additional requirement for Low-Ambient Controller (full modulation feature) MotorMaster® Control.

Accessory Description and Usage (Listed Alphabetically)

1. Ball-Bearing Fan Motor

A fan motor with ball bearings which permits speed reduction while maintaining bearing lubrication.

Usage Guideline:

Required on all units when using MotorMaster®

2. Compressor Start Assist - Capacitor and Relay

Start capacitor and relay gives a "hard" boost to compressor motor at each start up.

Usage Guideline:

Required for reciprocating compressors in the following applications:

- Long line
- Low ambient cooling
- Hard shut off expansion valve on indoor coil
- Liquid line solenoid on indoor coil

Required for single-phase scroll compressors in the following applications:

- Long line
- Low ambient cooling

Suggested for all compressors in areas with a history of low voltage problems.

3. Compressor Start Assist — PTC Type

Solid state electrical device which gives a "soft" boost to the compressor at each start-up.

Usage Guideline:

Suggested in installations with marginal power supply.

4. Crankcase Heater

An electric resistance heater which mounts to the base of the compressor to keep the lubricant warm during off cycles. Improves compressor lubrication on restart and minimizes the chance of liquid slugging.

Usage Guideline:

- Required in low ambient cooling applications.
- Required in long line applications.
- Suggested in all commercial applications.

5. Evaporator Freeze Thermostat

An SPST temperature-actuated switch that stops unit operation when evaporator reaches freeze-up conditions.

Usage Guideline:

Required when low ambient kit has been added.

6. Isolation Relay

An SPDT relay which switches the low-ambient controller out of the outdoor fan motor circuit when the heat pump switches to heating mode.

Usage Guideline:

Required in all heat pumps where low ambient kit has been added.

7. Liquid-Line Solenoid Valve (LLS)

An electrically operated shutoff valve which stops and starts refrigerant liquid flow in response to compressor operation. It is to be installed at the outdoor unit to control refrigerant off cycle migration in the heating mode.

Usage Guideline:

An LLS is required in all long line heat pump applications to control refrigerant off cycle migration in the heating mode. See Long Line Guideline.

8. Low-Ambient Pressure Switch Kit

A long life pressure switch which is mounted to outdoor unit service valve. It is designed to cycle the outdoor fan motor in order to maintain head pressure within normal operating limits. The control will maintain working head pressure at low-ambient temperatures down to 0°F (-17.8°C) when properly installed.

Usage Guideline:

A Low-Ambient Pressure Switch or MotorMaster® Low-Ambient Controller must be used when cooling operation is used at outdoor temperatures below 55°F (12.8°C).

9. MotorMaster® Low-Ambient Controller

A fan-speed control device activated by a temperature sensor, designed to control condenser fan motor speed in response to the saturated, condensing temperature during operation in cooling mode only. For outdoor temperatures down to -20°F (-28.9°C), it maintains condensing temperature at 100°F ±10°F (37.8°C ± 6.5°C).

Usage Guideline:

A MotorMaster® Low Ambient Controller or Low-Ambient Pressure Switch must be used when cooling operation is used at outdoor temperatures below 55°F (12.8°C).

Suggested for all commercial applications.

Accessory Description and Usage (Listed Alphabetically) - CONTINUED

10. Outdoor Air Temperature Sensor

Designed for use with Carrier Thermostats listed in this publication. This device enables the thermostat to display the outdoor temperature. This device also is required to enable special thermostat features such as auxiliary heat lock out.

Usage Guideline:

Suggested for all Carrier thermostats listed in this publication.

11. Outdoor Thermostat

An SPDT temperature-actuated switch which turns on supplemental electric heaters when outdoor air temperature drops below a user-selected set point.

Usage Guideline:

Electric supplemental heat applications in non-variable speed indoor units when electric heat staging is desired.

12. Secondary Outdoor Thermostat

An SPDT temperature-actuated switch which turns on third-stage of supplemental electric heaters when outdoor air temperature drops below the second-stage set point.

Usage Guideline:

Outdoor thermostat applications where electric heater is capable of three-stage operation.

13. Snow Stand

Coated wire rack which supports unit 18 in. (457.2 mm) above mounting pad to allow for drainage from unit base.

Usage Guideline:

Suggested in the following applications:

Heat pump installations in heavy snowfall areas.

Heat pump installations in snow drift locations.

Heat pump installations in areas of prolonged subfreezing temperatures.

All commercial installations.

14. Thermostatic Expansion Valve (TXV) Bi-Flow

A modulating flow-control valve which meters refrigerant liquid flow rate into the evaporator in response to the superheat of the refrigerant gas leaving the evaporator.

Usage Guideline:

Accessory required to meet AHRI rating and system reliability, where indoor not equipped.

Required in all heat pump applications designed with Puron refrigerant.

15. Time-Delay Relay

An SPST delay relay which briefly continues operation of indoor blower motor to provide additional cooling after the compressor cycles off.

Note: Most indoor unit controls include this feature. For those that do not, use the guideline below.

Usage Guideline:

Accessory required to meet AHRI rating, where indoor not equipped.

ELECTRICAL DATA

UNIT SIZE	V/PH	OPER VOLTS*		COMPR		FAN	MCA	MIN WIRE SIZE†	MIN WIRE SIZE†	MAX LENGTH ft (m)††	MAX LENGTH ft (m)††	MAX FUSE** or CKT BRK AMPS
		MAX	MIN	LRA	RLA	FLA		60° C	75° C	60° C	75° C	
18-30	208/230/1	253	197	48.0	9.00	0.5	11.8	14	14	67 (20.4)	63 (19.2)	20
24-30				58.3	12.80	0.5	16.5	14	14	48 (14.6)	45 (13.7)	25
30-30				73.0	14.10	0.5	18.1	14	14	44 (13.4)	41 (12.5)	30
36-30				79.0	16.70	1.2	22.1	12	12	57 (17.4)	54 (16.5)	35
42-30				109.0	21.10	1.2	27.6	10	10	72 (21.9)	69 (21.0)	40
48-30				117.0	21.80	1.2	28.5	10	10	70 (21.3)	67 (20.4)	40
60-30				134.0	26.40	1.2	34.2	8	10	91 (27.7)	56 (17.1)	50

* Permissible limits of the voltage range at which the unit will operate satisfactorily

† If wire is applied at ambient greater than 30°C, consult table 310-16 of the NEC (ANSI/NFPA 70). The ampacity of non-metallic-sheathed cable (NM), trade name ROMEX, shall be that of 60°C conditions, per the NEC (ANSI/NFPA 70) Article 336-26. If other than uncoated (no-plated), 60 or 75°C insulation, copper wire (solid wire for 10 AWG or smaller, stranded wire for larger than 10 AWG) is used, consult applicable tables of the NEC (ANSI/NFPA 70).

‡ Length shown is as measured 1 way along wire path between unit and service panel for voltage drop not to exceed 2%.

** Time-Delay fuse.

FLA - Full Load Amps

LRA - Locked Rotor Amps

MCA - Minimum Circuit Amps

RLA - Rated Load Amps

NOTE: Control circuit is 24-V on all units and requires external power source. Copper wire must be used from service disconnect to unit.

All motors/compressors contain internal overload protection.

Complies with 2007 requirements of ASHRAE Standards 90.1

25HCC5

A-WEIGHTED SOUND POWER

UNIT SIZE - VOLTAGE, SERIES	STANDARD RATING (dBA)	TYPICAL OCTAVE BAND SPECTRUM (dBA, without tone adjustment)						
		125	250	500	1000	2000	4000	8000
18-30	72	50.5	60.0	65.0	67.5	64.5	61.5	53.5
24-30	68	49.5	58.5	61.5	62.0	61.0	58.5	51.5
30-30	69	50.5	58.5	61.5	64.0	61.5	58.5	51.5
36-30	70	54.5	57.5	63.0	66.0	64.0	61.0	54.0
42-30	72	56.5	64.5	66.5	66.5	64.5	61.0	54.5
48-30	72	58.5	63.0	65.5	67.0	63.5	60.0	52.0
60-30	73	58.5	62.5	65.0	67.0	64.0	61.0	56.5

NOTE: Tested in accordance with AHRI Standard 270-08 (not listed in AHRI).

CHARGING SUBCOOLING (TXV-TYPE EXPANSION DEVICE)

UNIT SIZE - VOLTAGE, SERIES	REQUIRED SUBCOOLING ° F (° C)
18-30	12 (6.7)
24-30	14 (7.8)
30-30	10 (5.6)
36-30	8 (4.4)
42-30	10 (5.6)
48-30	11 (6.1)
60-30	10 (5.6)

DIMENSIONS - ENGLISH

UNIT	SERIES	ELECTRICAL CHARACTERISTICS	A	B	C	D	E	F	G	K	L	M	N	P	OPERATING WEIGHT (lbs)	SHIPPING WEIGHT (lbs)	SHIPPING DIMENSIONS (L x W x H)
25HCC518	0	X 0 0 0	31 3/16"	28 15/16"	3 3/4"	5/8"	6 9/16"	24 11/16"	9 1/8"	2 13/16"	1/2"	16"	15"	14"	169	207	32 5/16" X 35 1/2" X 32 9/16"
25HCC524	0	X 0 0 0	35"	32 5/16"	3 3/4"	5/8"	6 9/16"	28 7/16"	9 1/8"	2 13/16"	1/2"	15 3/4"	16 3/4"	16 1/2"	200	233	36 1/8" X 39 1/4" X 35 15/16"
25HCC530	0	X 0 0 0	35"	32 5/16"	3 3/4"	3/4"	6 9/16"	28 7/16"	9 1/8"	2 13/16"	1/2"	16 1/4"	16"	15 1/2"	196	242	36 1/8" X 39 1/4" X 35 15/16"
25HCC536	0	X 0 0 0	35"	35 3/4"	3 3/4"	3/4"	6 9/16"	28 7/16"	9 1/8"	2 13/16"	1/2"	15 3/4"	16 3/4"	17"	215	257	36 1/8" X 39 1/4" X 39 3/8"
25HCC542	0	X 0 0 0	35"	28 15/16"	3 7/8"	7/8"	6 9/16"	28 7/16"	9 1/8"	2 15/16"	5/8"	17"	16 3/4"	14 3/4"	245	290	36 1/8" X 39 1/4" X 32 9/16"
25HCC548	0	X 0 0 0	35"	28 15/16"	3 7/8"	7/8"	6 9/16"	28 7/16"	9 1/8"	2 15/16"	5/8"	16 3/4"	16 1/4"	14"	260	303	36 1/8" X 39 1/4" X 32 9/16"
25HCC560	0	X 0 0 0	35"	39 1/8"	3 7/8"	7/8"	6 9/16"	28 7/16"	9 1/8"	2 15/16"	5/8"	17 1/4"	16 1/4"	18 1/4"	294	345	36 1/8" X 39 1/4" X 42 3/4"

NOTES:

1. ALLOW 30" CLEARANCE TO SERVICE SIDE OF UNIT, 48" ABOVE UNIT, 6" ON ONE SIDE, 12" ON REMAINING SIDE, AND 24" BETWEEN UNITS FOR PROPER AIRFLOW.
2. MINIMUM OUTDOOR OPERATING AMBIENT IN COOLING MODE IS 35°F, MAX. 125°F.
3. SERIES DESIGNATION IS THE 13TH POSITION OF THE UNIT MODEL NUMBER.
4. CENTER OF GRAVITY 
5. ALL DIMENSIONS ARE IN *INCHES* UNLESS NOTED.

X = YES
0 = NO

208-230-160	230-160	208/230-3-60	460-3-60
-------------	---------	--------------	----------

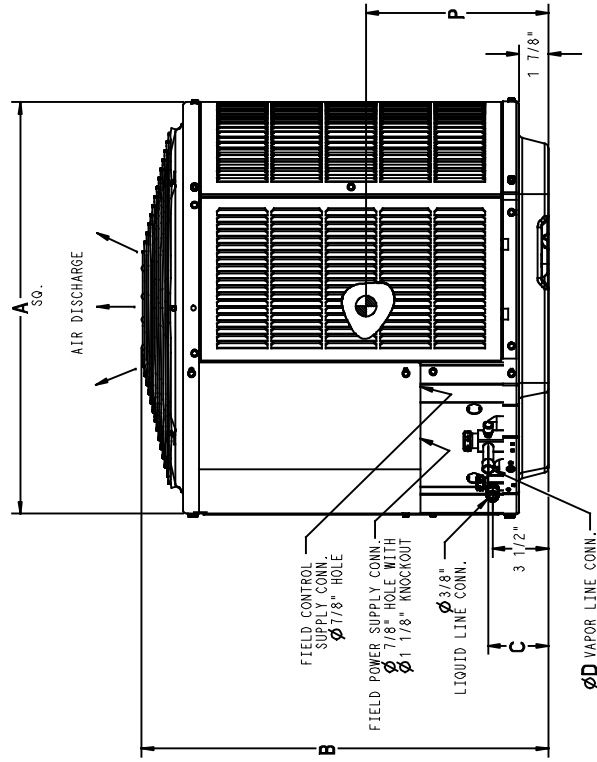
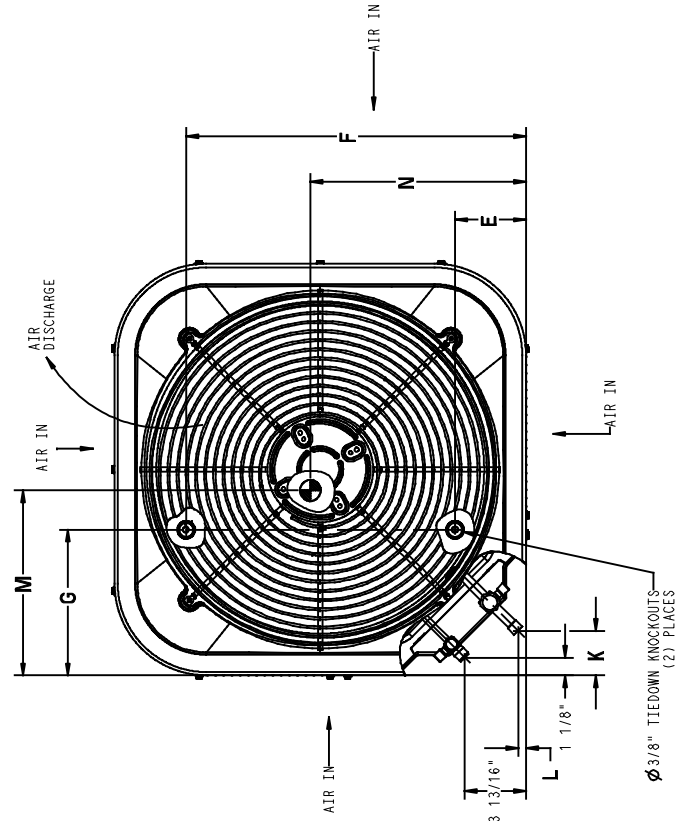

UNIT SIZE	MINIMUM MOUNTING PAD DIMENSIONS
-	26" X 26"
18	31 1/2" X 31 1/2"
24, 30, 36, 42, 48, 60	35" X 35"

25HCC5

25HC518

DIMENSIONS - SI

UNIT	SERIES	ELECTRICAL CHARACTERISTICS	DIMENSIONS (mm)													OPERATING WEIGHT (Kgs)	SHIPPING WEIGHT (Kgs)	SHIPPING DIMENSIONS (L x W x H)
			A	B	C	D	E	F	G	K	L	M	N	P				
25HC518	0	X 0 0 0	792.5	734.8	95.6	15.9	166.1	626.3	231.3	231.3	70.9	12.8	406.4	381.0	355.6	16.7	93.9	821.2 X 901.2 X 826.8
25HC524	0	X 0 0 0	889.0	821.2	95.6	15.9	166.1	722.8	231.3	231.3	70.9	12.8	400.1	425.5	419.1	90.8	105.7	917.7 X 997.7 X 913.2
25HC530	0	X 0 0 0	889.0	821.2	95.6	19.1	166.1	722.8	231.3	231.3	70.9	12.8	406.4	406.4	393.7	88.9	109.8	917.7 X 997.7 X 913.2
25HC536	0	X 0 0 0	889.0	907.5	95.6	19.1	166.1	722.8	231.3	231.3	70.9	12.8	400.1	425.5	431.8	91.5	116.6	917.7 X 997.7 X 999.5
25HC542	0	X 0 0 0	889.0	734.8	97.9	22.2	166.1	722.8	231.3	231.3	74.5	16.3	431.8	425.5	374.7	111.1	131.5	917.7 X 997.7 X 826.8
25HC548	0	X 0 0 0	889.0	734.8	97.9	22.2	166.1	722.8	231.3	231.3	74.5	16.3	425.5	412.8	355.6	117.9	137.4	917.7 X 997.7 X 826.8
25HC560	0	X 0 0 0	889.0	993.9	97.9	22.2	166.1	722.8	231.3	231.3	74.5	16.3	438.2	412.8	463.6	113.4	156.5	917.7 X 997.7 X 1085.9

X = YES
0 = NO

460-3-60	208/230-3-60	208-230-1-60
230-1-60		

- NOTES:
- ALLOW 762.0 CLEARANCE TO SERVICE SIDE OF UNIT.
1219.2 ABOVE UNIT 152.4 ON ONE SIDE 304.8 ON REMAINING SIDE,
AND 609.6 BETWEEN UNITS FOR PROPER AIRFLOW.
 - MINIMUM OUTDOOR OPERATING AMBIENT IN COOLING MODE IS 13°C, MAX. 52°C.
 - SERIES DESIGNATION IS THE 13TH POSITION OF THE UNIT MODEL NUMBER.
 - CENTER OF GRAVITY
 - ALL DIMENSIONS ARE IN "MM" UNLESS NOTED.

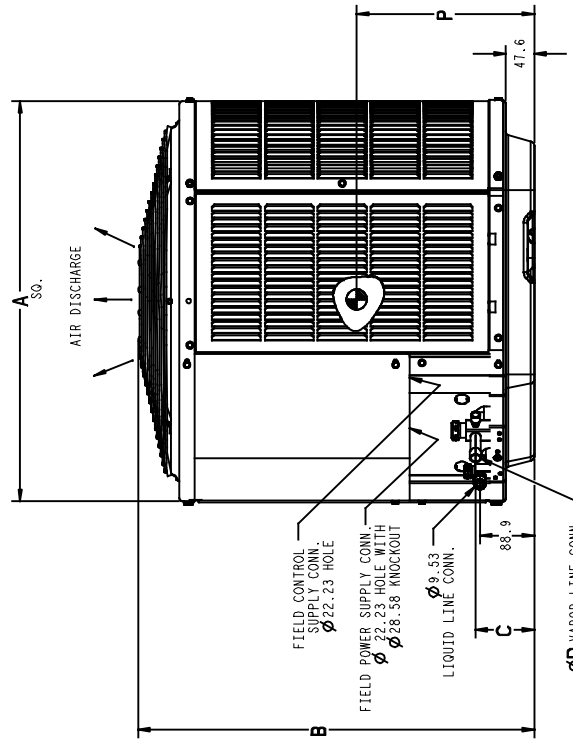
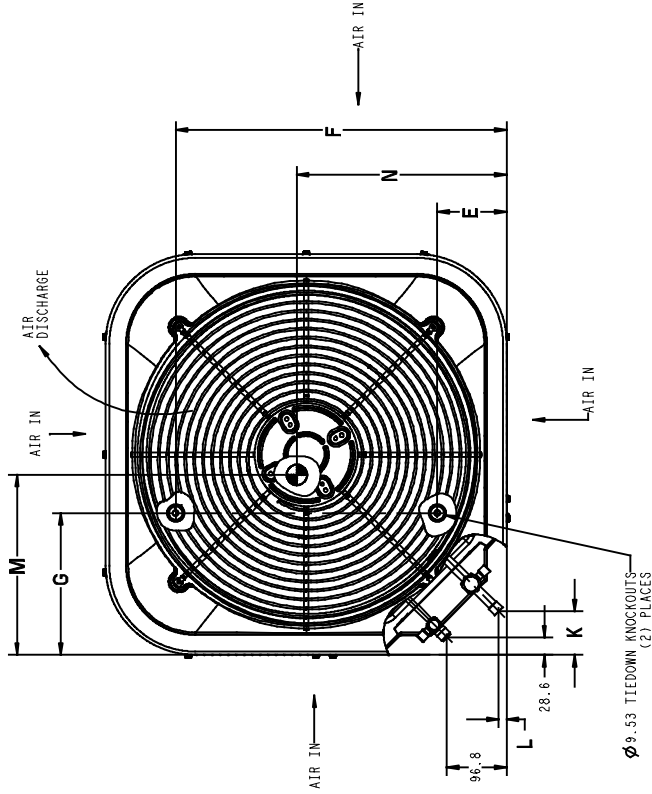

UNIT SIZE	MINIMUM MOUNTING PAD DIMENSIONS
-	660.4 X 660.4
18	800.1 X 800.1
24, 30, 36, 42, 48, 60	885.0 X 885.0

25HCC5 BALANCE POINT WORKSHEET

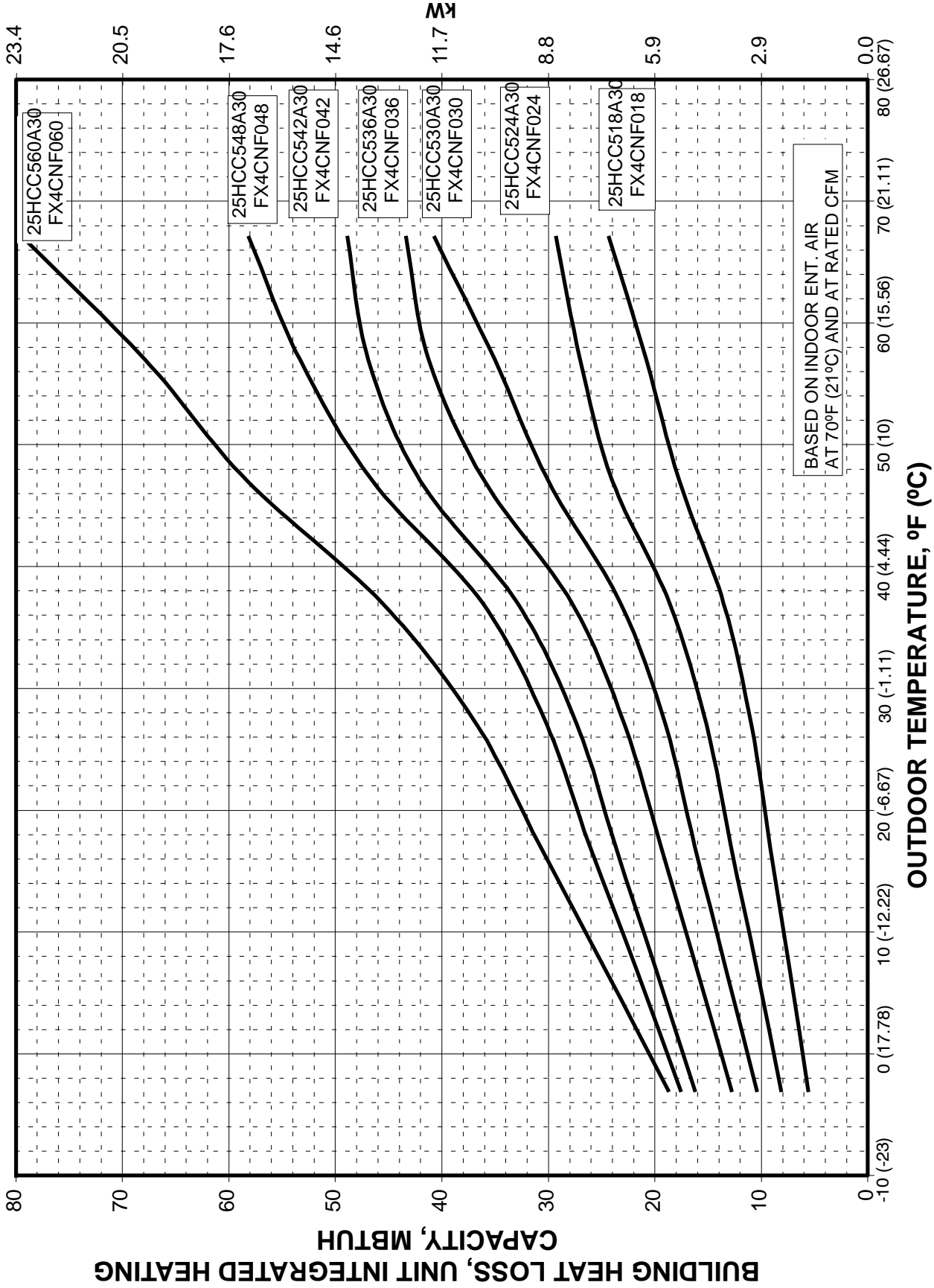

25HCC5

CLEARANCES

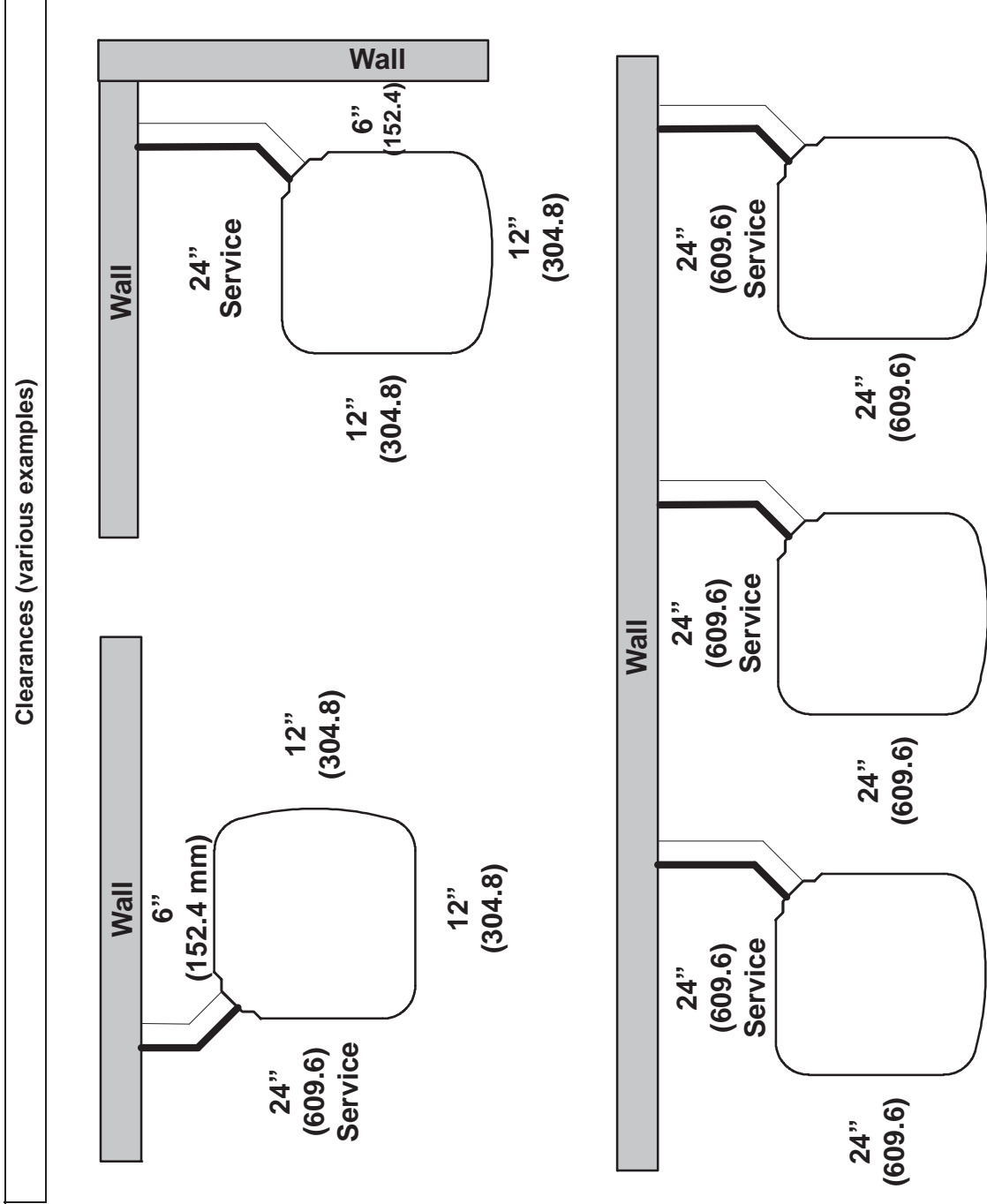

Note: Numbers in () = mm

IMPORTANT: When installing multiple units in an alcove, roof well, or partially enclosed area, ensure there is adequate ventilation to prevent re-circulation of discharge air.

TESTED AHRI COMBINATION RATINGS*

NOTE: Ratings contained in this document are subject to change at any time.

For AHRI ratings certificates, please refer to the AHRI directory www.ahridirectory.org

Additional ratings and system combinations can be accessed via the Carrier database at:

http://cactaxcredits.info/carrier-ratings/ac_ratings_srch.php

Equipment performance calculator can be accessed at: <http://rpmob.wrightsoft.com/>

Model Number	Coil Model Number	Furnace Model Number	Cooling Capacity	EER	SEER	High Temp		HSPF	Low Temp	
						E Capacity	E COP		H Capacity	H COP
25HCC518A**30	FX4DNF019		17,800	12.6	15.3	17,400	3.88	8.6	10,600	2.56
25HCC524A**30	FX4DNF025		24,000	12.5	15.3	24,000	3.94	8.7	14,800	2.70
25HCC530A**30	FX4DN(B,F)031		28,400	12.5	15.3	28,400	3.98	8.7	17,000	2.66
25HCC536A**30	FX4DN(B,F)037		34,800	12.5	15.0	35,200	3.88	8.7	22,000	2.64
25HCC542A**30	FX4DN(B,F)043		41,500	12.5	15.0	41,500	3.80	8.7	26,800	2.60
25HCC548A**30	FX4DN(B,F)049		47,500	12.5	15.0	46,500	3.84	8.7	28,000	2.66
25HCC560A**30	FX4DN(B,F)061		57,000	12.5	15.0	57,000	3.84	8.5	35,400	2.68

* AHRI = Air Conditioning, Heating & Refrigeration Institute

Ratings are net values reflecting the effects of circulating fan heat. Supplemental electric heat is not included. Ratings are based on:

Cooling Standard: 80°F (27°C) db 67°F (19°C) wb indoor entering air temperature and 95°F (35°C) db air entering outdoor unit.

High-Temp Heating Standard: 70°F (21°C) db indoor entering air temperature and 47°F (8°C) db 43°F (6°C) wb air entering outdoor unit.

Low-Temp Heating Standard: 70°F (21°C) db indoor entering air temperature and 17°F (-8°C) db 15°F (-9°C) wb air entering outdoor unit.

COP — Coefficient of Performance

EER — Energy Efficiency Ratio

HSPF — Heating Seasonal Performance Factor

SEER — Seasonal Energy Efficiency Ratio

25HCC5

DETAILED COOLING CAPACITIES#

EVAPORATOR AIR		CONDENSER ENTERING AIR TEMPERATURES ° F (° C)																	
		75 (23.9)			85 (29.4)			95 (35)			105 (40.6)			115 (46.1)			125 (51.7)		
		CFM	EWB ° F (° C)	Capacity Total	Capacity MBtu/ht Sens†	Total Sys-tem KW**	Capacity Total	Capacity MBtu/ht Sens†	Total Sys-tem KW**	Capacity Total	Capacity MBtu/ht Sens†	Total Sys-tem KW**	Capacity Total	Capacity MBtu/ht Sens†	Total Sys-tem KW**	Capacity Total	Capacity MBtu/ht Sens†	Total Sys-tem KW**	
25HCC518A30 Outdoor Section With FX4DNF019 Indoor Section																			
525	72 (22.2)	21.38	11.10	1.10	20.34	10.70	1.25	19.25	10.28	1.42	18.10	9.85	1.60	16.88	9.40	1.80	15.59	8.93	2.03
	67 (19.4)	19.37	13.52	1.10	18.43	13.12	1.25	17.43	12.70	1.41	16.38	12.26	1.59	15.26	11.81	1.79	14.08	11.33	2.02
	63 (17.2)††	17.92	13.00	1.10	17.05	12.60	1.25	16.12	12.18	1.41	15.14	11.74	1.59	14.10	11.28	1.79	12.99	10.80	2.01
	62 (16.7)	17.54	15.88	1.10	16.69	15.47	1.25	15.79	15.04	1.41	14.85	14.58	1.59	13.91	13.91	1.78	13.03	13.03	2.01
	57 (13.9)	16.80	16.80	1.10	16.15	16.15	1.25	15.45	15.45	1.41	14.70	14.70	1.59	13.89	13.89	1.78	13.01	13.01	2.01
600	72 (22.2)	21.87	11.69	1.11	20.79	11.28	1.26	19.64	10.85	1.43	18.44	10.41	1.61	17.17	9.95	1.81	15.83	9.47	2.04
	67 (19.4)	19.84	14.44	1.11	18.85	14.03	1.26	17.80	13.60	1.42	16.70	13.15	1.60	15.54	12.69	1.80	14.31	12.20	2.03
	63 (17.2)††	18.37	13.86	1.11	17.45	13.45	1.26	16.48	13.02	1.42	15.45	12.57	1.60	14.37	12.10	1.80	13.22	11.61	2.02
	62 (16.7)	18.01	17.11	1.11	17.13	16.68	1.26	16.21	16.12	1.42	15.36	15.36	1.60	14.49	14.49	1.80	13.56	13.56	2.02
	57 (13.9)	17.61	17.61	1.11	16.90	16.90	1.26	16.15	16.15	1.42	15.34	15.34	1.60	14.47	14.47	1.80	13.54	13.54	2.02
675	72 (22.2)	22.26	12.24	1.12	21.13	11.82	1.27	19.94	11.39	1.44	18.70	10.94	1.62	17.39	10.48	1.82	16.02	10.00	2.05
	67 (19.4)	20.21	15.33	1.12	19.17	14.90	1.27	18.08	14.47	1.43	16.95	14.01	1.61	15.75	13.53	1.81	14.49	13.03	2.04
	63 (17.2)††	18.73	14.69	1.12	17.76	14.27	1.27	16.76	13.83	1.43	15.70	13.37	1.61	14.58	12.89	1.81	13.40	12.38	2.03
	62 (16.7)	18.42	18.24	1.12	17.56	17.56	1.27	16.76	16.76	1.43	15.90	15.90	1.61	14.98	14.98	1.81	14.00	14.00	2.04
	57 (13.9)	18.29	18.29	1.12	17.54	17.54	1.27	16.74	16.74	1.43	15.88	15.88	1.61	14.96	14.96	1.81	13.98	13.98	2.04

EVAPORATOR AIR		CONDENSER ENTERING AIR TEMPERATURES ° F (° C)																	
		75 (23.9)			85 (29.4)			95 (35)			105 (40.6)			115 (46.1)			125 (51.7)		
		CFM	EWB ° F (° C)	Capacity Total	Capacity MBtu/ht Sens†	Total Sys-tem KW**	Capacity Total	Capacity MBtu/ht Sens†	Total Sys-tem KW**	Capacity Total	Capacity MBtu/ht Sens†	Total Sys-tem KW**	Capacity Total	Capacity MBtu/ht Sens†	Total Sys-tem KW**	Capacity Total	Capacity MBtu/ht Sens†	Total Sys-tem KW**	
25HCC524A30 Outdoor Section With FX4DNF025 Indoor Section																			
700	72 (22.2)	28.25	14.67	1.50	27.04	14.21	1.70	25.76	13.71	1.91	24.38	13.19	2.15	22.88	12.63	2.41	21.23	12.03	2.71
	67 (19.4)	25.63	17.92	1.48	24.52	17.44	1.67	23.33	16.94	1.88	22.05	16.40	2.12	20.66	15.83	2.38	19.12	15.20	2.68
	63 (17.2)††	23.76	17.24	1.46	22.71	16.76	1.66	21.59	16.25	1.87	20.38	15.71	2.10	19.07	15.13	2.37	17.61	14.49	2.68
	62 (16.7)	23.28	21.08	1.46	22.25	20.58	1.65	21.17	20.06	1.87	20.00	19.48	2.10	18.77	18.68	2.37	17.59	17.59	2.68
	57 (13.9)	22.30	22.30	1.46	21.50	21.50	1.65	20.65	20.65	1.86	19.72	19.72	2.10	18.70	18.70	2.37	17.56	17.56	2.68
800	72 (22.2)	28.87	15.41	1.53	27.60	14.93	1.73	26.26	14.44	1.94	24.83	13.91	2.17	23.27	13.34	2.44	21.57	12.73	2.73
	67 (19.4)	26.21	19.09	1.50	25.04	18.60	1.69	23.80	18.09	1.90	22.47	17.55	2.14	21.02	16.96	2.40	19.44	16.32	2.71
	63 (17.2)††	24.31	18.34	1.48	23.21	17.84	1.68	22.04	17.33	1.89	20.78	16.77	2.12	19.42	16.18	2.39	17.92	15.53	2.70
	62 (16.7)	23.85	22.64	1.48	22.80	22.10	1.68	21.69	21.51	1.89	20.58	20.58	2.12	19.49	19.49	2.39	18.28	18.28	2.70
	57 (13.9)	23.30	23.30	1.48	22.45	22.45	1.67	21.53	21.53	1.89	20.55	20.55	2.12	19.46	19.46	2.39	18.26	18.26	2.70
900	72 (22.2)	29.34	16.11	1.56	28.03	15.63	1.75	26.65	15.12	1.96	25.17	14.59	2.20	23.56	14.01	2.46	21.82	13.39	2.76
	67 (19.4)	26.65	20.21	1.52	25.44	19.71	1.72	24.16	19.19	1.98	22.79	18.68	2.16	21.30	18.03	2.43	19.68	17.38	2.73
	63 (17.2)††	24.73	19.38	1.50	23.59	18.88	1.70	22.39	18.35	1.91	21.09	17.78	2.14	19.69	17.17	2.41	18.16	16.50	2.71
	62 (16.7)	24.35	24.04	1.50	23.29	23.29	1.70	22.31	22.31	1.91	21.27	21.27	2.15	20.12	20.12	2.41	18.86	18.86	2.72
	57 (13.9)	24.14	24.14	1.50	23.24	23.24	1.70	22.28	22.28	1.91	21.24	21.24	2.15	20.10	20.10	2.41	18.84	18.84	2.72

See note on pg. 17

DETAILED COOLING CAPACITIES# CONTINUED

EVAPORATOR AIR		CONDENSER ENTERING AIR TEMPERATURES ° F (° C)																	
		75 (23.9)			85 (29.4)			95 (35)			105 (40.6)			115 (46.1)			125 (51.7)		
		CFM	EWB ° F (° C)	Capacity MBtu/ht		Total Sys-tem KW**	Capacity MBtu/ht		Total Sys-tem KW**	Capacity MBtu/ht		Total Sys-tem KW**	Capacity MBtu/ht		Total Sys-tem KW**	Capacity MBtu/ht		Total Sys-tem KW**	
				Total	Sens†		Total	Sens†		Total	Sens†		Total	Sens†		Total	Sens†		Total
25HCC550A30 Outdoor Section With FX4DNF031 Indoor Section																			
	72 (22.2)	34.40	17.74	32.81	17.14	2.05	31.16	16.52	2.29	29.42	15.88	2.56	27.55	15.20	2.87	25.53	14.48	3.23	
	67 (19.4)	31.23	21.80	29.80	21.20	2.04	28.29	20.57	2.28	26.69	19.93	2.55	24.96	19.24	2.86	23.10	18.49	3.22	
875	63 (17.2)††	28.95	20.97	27.62	20.37	2.03	26.22	19.74	2.27	24.73	19.09	2.54	23.11	18.39	2.86	21.35	17.64	3.22	
	62 (16.7)	28.38	25.74	27.09	25.12	2.03	25.75	24.46	2.26	24.33	23.73	2.54	22.91	22.91	2.86	21.51	21.51	3.22	
	57 (13.9)	27.40	27.40	26.39	26.39	2.02	25.32	25.32	2.26	24.15	24.15	2.54	22.88	22.88	2.86	21.48	21.48	3.22	
	72 (22.2)	35.08	18.63	33.43	18.02	2.08	31.71	17.39	2.32	29.89	16.74	2.59	27.95	16.05	2.90	25.86	15.32	3.25	
	67 (19.4)	31.88	23.23	30.37	22.61	2.06	28.80	21.98	2.30	27.13	21.31	2.58	25.35	20.60	2.89	23.43	19.84	3.24	
1000	63 (17.2)††	29.57	22.30	28.18	21.68	2.05	26.71	21.05	2.29	25.16	20.38	2.57	23.47	19.66	2.88	21.67	18.88	3.24	
	62 (16.7)	29.06	27.61	27.73	26.92	2.05	26.39	26.39	2.29	25.13	25.13	2.57	23.77	23.77	2.88	22.28	22.28	3.24	
	57 (13.9)	28.58	28.58	27.49	27.49	2.05	26.34	26.34	2.29	25.10	25.10	2.57	23.74	23.74	2.88	22.26	22.26	3.24	
	72 (22.2)	35.61	19.48	33.89	18.86	2.11	32.11	18.22	2.35	30.24	17.56	2.62	28.25	16.86	2.93	26.10	16.12	3.28	
	67 (19.4)	32.37	24.59	30.81	23.96	2.09	29.18	23.31	2.33	27.47	22.63	2.60	25.64	21.90	2.91	23.68	21.10	3.27	
1125	63 (17.2)††	30.05	23.56	28.60	22.94	2.08	27.09	22.29	2.32	25.49	21.60	2.59	23.78	20.86	2.91	21.93	20.05	3.27	
	62 (16.7)	29.68	29.51	28.45	28.45	2.08	27.22	27.22	2.32	25.91	25.91	2.60	24.49	24.49	2.91	22.92	22.92	3.27	
	57 (13.9)	29.56	29.56	28.41	28.41	2.08	27.19	27.19	2.32	25.88	25.88	2.59	24.46	24.46	2.91	22.89	22.89	3.27	

EVAPORATOR AIR		CONDENSER ENTERING AIR TEMPERATURES ° F (° C)																	
		75 (23.9)			85 (29.4)			95 (35)			105 (40.6)			115 (46.1)			125 (51.7)		
		CFM	EWB ° F (° C)	Capacity MBtu/ht		Total Sys-tem KW**	Capacity MBtu/ht		Total Sys-tem KW**	Capacity MBtu/ht		Total Sys-tem KW**	Capacity MBtu/ht		Total Sys-tem KW**	Capacity MBtu/ht		Total Sys-tem KW**	
				Total	Sens†		Total	Sens†		Total	Sens†		Total	Sens†		Total	Sens†		Total
25HCC556A30 Outdoor Section With FX4DNF037 Indoor Section																			
	72 (22.2)	41.59	22.07	39.75	21.35	2.51	37.77	20.58	2.79	35.67	19.78	3.11	33.40	18.93	3.48	30.96	18.02	3.90	
	67 (19.4)	37.90	27.12	36.20	26.38	2.48	34.37	25.90	2.77	32.42	24.78	3.09	30.32	23.91	3.45	28.05	22.97	3.88	
1050	63 (17.2)††	35.22	26.13	33.62	25.39	2.47	31.90	24.60	2.75	30.07	23.77	3.07	28.09	22.88	3.44	25.96	21.93	3.87	
	62 (16.7)	34.53	32.04	32.97	31.27	2.47	31.31	30.44	2.75	29.55	29.53	3.07	27.74	27.74	3.44	26.04	26.04	3.87	
	57 (13.9)	33.22	33.22	32.01	32.01	2.46	30.68	30.68	2.74	29.25	29.25	3.06	27.70	27.70	3.44	26.00	26.00	3.86	
	72 (22.2)	42.40	23.16	40.48	22.43	2.54	38.44	21.66	2.83	36.24	20.84	3.15	33.91	19.98	3.51	31.38	19.05	3.93	
	67 (19.4)	38.68	28.89	36.90	28.13	2.52	35.00	27.94	2.80	32.97	26.50	3.12	30.79	25.60	3.49	28.46	24.65	3.91	
1200	63 (17.2)††	35.97	27.78	34.30	27.02	2.50	32.52	26.22	2.78	30.61	25.37	3.10	28.56	24.46	3.47	26.36	23.49	3.90	
	62 (16.7)	35.34	34.38	33.74	33.54	2.50	32.07	31.86	2.78	30.45	30.45	3.10	28.80	28.80	3.47	26.99	26.99	3.90	
	57 (13.9)	34.65	34.65	33.35	33.35	2.50	31.93	31.93	2.78	30.41	30.41	3.10	28.76	28.76	3.47	26.96	26.96	3.90	
	72 (22.2)	43.03	24.20	41.06	23.46	2.58	38.93	22.68	2.86	36.68	21.85	3.18	34.27	20.98	3.55	31.68	20.04	3.96	
	67 (19.4)	39.27	30.57	37.43	29.81	2.55	35.47	29.00	2.83	33.38	28.14	3.15	31.16	27.22	3.52	28.76	26.23	3.94	
1350	63 (17.2)††	36.55	29.35	34.82	28.58	2.53	32.98	27.76	2.81	31.02	26.89	3.13	28.92	25.95	3.50	26.67	24.94	3.93	
	62 (16.7)	36.05	36.44	34.51	34.51	2.53	33.01	33.01	2.81	31.41	31.41	3.14	29.67	29.67	3.51	27.77	27.77	3.93	
	57 (13.9)	35.84	35.84	34.46	34.46	2.53	32.97	32.97	2.81	31.37	31.37	3.14	29.63	29.63	3.51	27.74	27.74	3.93	

See note on pg. 17



DETAILED COOLING CAPACITIES# CONTINUED

EVAPORATOR AIR		CONDENSER ENTERING AIR TEMPERATURES ° F (° C)																			
CFM	EWB ° F (° C)	75 (23.9)			85 (29.4)			95 (35)			105 (40.6)			115 (46.1)			125 (51.7)				
		Capacity MBtu/ht Total	Sens#	Total Sys-tem KW**	Capacity MBtu/ht Total	Sens#	Total Sys-tem KW**	Capacity MBtu/ht Total	Sens#	Total Sys-tem KW**	Capacity MBtu/ht Total	Sens#	Total Sys-tem KW**	Capacity MBtu/ht Total	Sens#	Total Sys-tem KW**	Capacity MBtu/ht Total	Sens#	Total Sys-tem KW**		
25HCC5/42/30 Outdoor Section With FX4DNF043 Indoor Section																					
	72 (22.2)	50.43	25.70	2.47	48.01	24.76	2.86	45.51	23.81	42.89	22.83	3.26	42.89	22.83	3.69	40.16	21.82	4.13	37.25	20.76	4.61
	67 (19.4)	45.85	31.32	2.59	43.47	30.39	2.98	41.22	29.44	38.86	28.47	3.33	38.86	28.47	3.73	36.38	27.46	4.15	33.74	26.40	4.62
1225	63 (17.2)††	42.23	30.12	2.67	40.23	29.20	3.01	38.16	28.26	35.97	27.30	3.36	35.97	27.30	3.74	33.68	26.29	4.16	31.23	25.22	4.61
	62 (16.7)	41.36	36.82	2.68	39.42	35.88	3.02	37.42	34.91	33.87	33.87	3.37	35.93	33.87	3.75	33.17	32.70	4.16	31.09	31.09	4.61
	57 (13.9)	39.50	39.50	2.72	38.01	36.44	3.04	36.44	36.44	34.77	34.77	3.38	34.77	34.77	3.75	32.98	32.98	4.16	31.05	31.05	4.61
	72 (22.2)	51.53	26.95	2.47	48.98	25.98	2.88	46.35	25.01	43.62	24.01	3.29	43.62	24.01	3.72	40.76	22.98	4.17	37.75	21.90	4.65
	67 (19.4)	46.66	33.31	2.60	44.38	32.35	2.98	42.00	31.37	39.54	30.39	3.36	39.54	30.39	3.76	36.95	29.35	4.19	34.21	28.25	4.66
1400	63 (17.2)††	43.19	31.97	2.69	41.08	31.02	3.04	38.90	30.06	36.62	29.07	3.40	36.62	29.07	3.78	34.22	28.03	4.20	31.69	26.94	4.66
	62 (16.7)	42.38	39.45	2.70	40.35	38.44	3.05	38.28	37.36	36.20	36.20	3.40	36.20	36.20	3.78	34.27	34.27	4.20	32.20	32.20	4.66
	57 (13.9)	41.23	41.23	2.72	39.62	39.62	3.06	37.93	37.93	36.14	36.14	3.41	36.14	36.14	3.78	34.22	34.22	4.20	32.16	32.16	4.66
	72 (22.2)	52.37	28.11	2.48	49.72	27.13	2.90	47.00	26.14	44.15	25.12	3.31	44.15	25.12	3.75	41.21	24.07	4.20	38.11	22.98	4.69
	67 (19.4)	47.45	35.19	2.62	45.05	34.20	3.00	42.59	33.23	40.05	32.20	3.39	40.05	32.20	3.80	37.37	31.13	4.23	34.58	30.00	4.70
1575	63 (17.2)††	43.93	33.72	2.71	41.73	32.75	3.07	39.46	31.77	37.10	30.75	3.43	37.10	30.75	3.82	34.64	29.68	4.24	32.04	28.94	4.70
	62 (16.7)	43.23	41.84	2.72	41.18	40.82	3.07	39.23	39.23	37.32	37.32	3.43	37.32	37.32	3.82	35.29	35.29	4.24	33.12	33.12	4.70
	57 (13.9)	42.69	42.69	2.73	40.98	40.98	3.08	39.18	39.18	37.28	37.28	3.44	37.28	37.28	3.82	35.25	35.25	4.24	33.08	33.08	4.70
CONDENSER ENTERING AIR TEMPERATURES ° F (° C)																					
CFM	EWB ° F (° C)	75 (23.9)			85 (29.4)			95 (35)			105 (40.6)			115 (46.1)			125 (51.7)				
		Capacity MBtu/ht Total	Sens#	Total Sys-tem KW**	Capacity MBtu/ht Total	Sens#	Total Sys-tem KW**	Capacity MBtu/ht Total	Sens#	Total Sys-tem KW**	Capacity MBtu/ht Total	Sens#	Total Sys-tem KW**	Capacity MBtu/ht Total	Sens#	Total Sys-tem KW**	Capacity MBtu/ht Total	Sens#	Total Sys-tem KW**		
25HCC5/48/30 Outdoor Section With FX4DNF049 Indoor Section																					
	72 (22.2)	57.26	29.51	2.88	54.23	28.34	3.32	51.16	27.19	48.02	26.02	3.75	48.02	26.02	4.19	44.73	24.81	4.85	41.29	23.57	5.16
	67 (19.4)	52.18	36.28	2.92	49.48	35.14	3.33	46.73	33.99	43.90	32.83	3.74	43.90	32.83	4.17	40.93	31.62	4.82	37.80	30.36	5.14
1400	63 (17.2)††	48.48	34.97	2.94	46.01	33.84	3.34	43.48	32.71	40.88	31.55	3.73	40.88	31.55	4.15	38.14	30.36	4.80	35.25	29.10	5.11
	62 (16.7)	47.52	42.88	2.95	45.12	41.72	3.34	42.69	40.54	39.27	39.27	3.73	40.19	39.27	4.14	37.70	37.70	4.60	35.35	35.35	5.12
	57 (13.9)	45.66	45.66	2.96	43.79	43.79	3.34	41.86	41.86	39.82	39.82	3.72	39.82	39.82	4.14	37.65	37.65	4.80	35.30	35.30	5.12
	72 (22.2)	58.35	30.94	2.92	55.18	29.75	3.36	51.96	28.57	48.68	27.37	3.80	48.68	27.37	4.24	45.27	26.15	4.71	41.70	24.88	5.22
	67 (19.4)	53.25	38.62	2.96	50.38	37.44	3.38	47.50	36.26	44.54	35.07	3.79	44.54	35.07	4.22	41.45	33.83	4.88	38.22	32.53	5.19
1600	63 (17.2)††	49.51	37.15	2.98	46.89	35.98	3.38	44.25	34.83	41.52	33.64	3.78	41.52	33.64	4.20	38.69	32.41	4.86	35.70	31.12	5.17
	62 (16.7)	48.61	45.99	2.99	46.11	44.72	3.38	43.64	43.39	41.34	41.34	3.78	41.34	41.34	4.20	39.01	39.01	4.66	36.50	36.50	5.18
	57 (13.9)	47.59	47.59	2.99	45.57	45.57	3.38	43.48	43.48	41.28	41.28	3.78	41.28	41.28	4.20	38.96	38.96	4.66	36.46	36.46	5.18
	72 (22.2)	59.17	32.29	2.96	55.88	31.08	3.41	52.54	29.88	49.16	28.67	3.84	49.16	28.67	4.29	45.65	27.43	4.76	41.98	26.15	5.27
	67 (19.4)	54.02	40.84	3.00	51.05	39.64	3.42	48.06	38.43	45.00	37.20	3.84	45.00	37.20	4.27	41.84	35.93	4.73	38.52	34.58	5.24
1800	63 (17.2)††	50.28	39.22	3.03	47.57	38.03	3.43	44.82	36.83	42.01	35.62	3.83	42.01	35.62	4.25	39.10	34.35	4.71	36.04	33.00	5.22
	62 (16.7)	49.55	48.76	3.03	47.11	47.11	3.43	44.87	44.87	42.54	42.54	3.83	42.54	42.54	4.26	40.07	40.07	4.72	37.40	37.40	5.23
	57 (13.9)	49.21	49.21	3.03	47.04	47.04	3.43	44.81	44.81	42.49	42.49	3.83	42.49	42.49	4.26	40.03	40.03	4.72	37.36	37.36	5.23

See note on pg. 17

DETAILED COOLING CAPACITIES# CONTINUED

EVAPORATOR AIR		CONDENSER ENTERING AIR TEMPERATURES °F (°C)																	
CFM	EWB °F (°C)	75 (23.9)			85 (29.4)			95 (65)			105 (40.6)			115 (46.1)			125 (51.7)		
		Capacity Total	Capacity Sens†	Total Sys-tem KW**	Capacity Total	Capacity Sens†	Total Sys-tem KW**	Capacity Total	Capacity Sens†	Total Sys-tem KW**	Capacity Total	Capacity Sens†	Total Sys-tem KW**	Capacity Total	Capacity Sens†	Total Sys-tem KW**	Capacity Total	Capacity Sens†	Total Sys-tem KW**
		25HCC560A30 Outdoor Section With FX4DNF061 Indoor Section																	
	72 (22.2)	69.17	35.96	3.81	65.83	34.68	4.20	62.32	33.37	4.63	58.60	31.99	5.12	54.63	30.54	5.68	50.41	29.02	6.30
	67 (19.4)	63.19	44.51	3.74	60.19	43.24	4.13	57.00	41.92	4.56	53.83	40.55	5.05	50.02	39.09	5.61	46.18	37.54	6.25
	63 (17.2)††	58.86	42.93	3.69	56.08	41.67	4.08	53.14	40.35	4.51	50.02	38.98	5.00	46.68	37.53	5.56	43.12	35.99	6.21
	62 (16.7)	57.71	52.83	3.68	55.03	51.53	4.07	52.20	50.14	4.50	49.23	48.59	4.99	46.32	46.32	5.56	43.40	43.40	6.21
	57 (13.9)	55.78	55.78	3.66	53.67	53.67	4.05	51.40	51.40	4.49	48.93	48.93	4.99	46.26	46.26	5.56	43.34	43.34	6.21
	72 (22.2)	70.36	37.71	3.89	66.90	36.42	4.28	63.21	35.07	4.71	59.35	33.67	5.20	55.24	32.20	5.75	50.87	30.86	6.38
	67 (19.4)	64.35	47.38	3.82	61.20	46.09	4.21	57.88	44.75	4.64	54.36	43.33	5.13	50.63	41.84	5.69	46.66	40.25	6.32
	63 (17.2)††	59.99	45.61	3.77	57.09	44.32	4.15	54.01	42.98	4.59	50.76	41.57	5.08	47.31	40.08	5.64	43.61	38.48	6.28
	62 (16.7)	56.64	56.64	3.76	56.19	55.19	4.15	53.39	53.39	4.58	50.73	50.73	5.08	47.86	47.86	5.85	44.74	44.74	6.30
	57 (13.9)	56.06	58.06	3.75	55.76	55.76	4.14	53.31	53.31	4.58	50.67	50.67	5.08	47.80	47.80	5.85	44.69	44.69	6.29
	72 (22.2)	71.28	39.37	3.97	67.65	38.06	4.36	63.86	36.70	4.79	59.89	35.28	5.27	55.65	33.79	5.82	51.19	32.24	6.45
	67 (19.4)	65.22	50.14	3.89	61.95	48.81	4.28	58.50	47.43	4.71	54.89	45.99	5.20	51.06	44.45	5.76	47.00	42.79	6.39
	63 (17.2)††	60.84	48.17	3.84	57.83	46.84	4.23	54.65	45.48	4.66	51.31	44.03	5.15	47.75	42.48	5.71	43.99	40.82	6.35
	62 (16.7)	60.05	60.05	3.84	57.56	57.56	4.23	54.95	54.95	4.67	52.14	52.14	5.16	49.11	49.11	5.73	45.81	45.81	6.38
	57 (13.9)	59.92	59.92	3.84	57.48	57.48	4.23	54.88	54.88	4.67	52.08	52.08	5.16	49.05	49.05	5.73	45.76	45.76	6.38

† Total and sensible capacities are net capacities. Blower motor heat has been subtracted.

‡ Sensible capacities shown are based on 80°F (27°C) entering air at the indoor coil. For sensible capacities at other than 80°F (27°C), deduct 835 Btu/h (245 kW) per 1000 CFM (480 L/S) of indoor coil air for each degree below 80°F (27°C), or add 835 Btu/h (245 kW) per 1000 CFM (480 L/S) of indoor coil air per degree above 80°F (27°C).

Detailed cooling capacities are based on indoor and outdoor unit at the same elevation per AHRI standard 210/240-2010. If additional tubing length and/or indoor unit is located above outdoor unit, a slight variation in capacity may occur.



HEAT PUMP HEATING PERFORMANCE

INDOOR AIR		OUTDOOR COIL ENTERING AIR TEMPERATURES ° F (° C)																					
EDB ° F (° C)	CFM	-3 (-19.4)		7 (-13.9)		17 (-8.3)		27 (-2.8)		37 (2.8)		47 (8.3)		57 (13.9)		67 (19.4)							
		Capacity MBtuh	Total Sys. KWt	Capacity MBtuh	Total Sys. KWt	Capacity MBtuh	Total Sys. KWt	Capacity MBtuh	Total Sys. KWt	Capacity MBtuh	Total Sys. KWt	Capacity MBtuh	Total Sys. KWt	Capacity MBtuh	Total Sys. KWt	Capacity MBtuh	Total Sys. KWt						
65 (18.3)	525	5.13	4.72	7.34	6.75	9.76	8.90	11.12	12.54	11.13	1.18	15.15	13.76	1.24	18.08	18.08	1.32	21.28	21.28	1.41	24.15	24.15	1.48
	600	5.22	4.80	7.46	6.85	10.07	9.03	11.11	12.68	11.27	1.17	15.35	13.97	1.22	18.35	18.35	1.29	21.43	21.43	1.35	24.11	24.11	1.42
	675	5.30	4.87	7.55	6.94	10.04	9.15	11.11	12.80	11.37	1.16	15.51	14.12	1.20	18.56	18.56	1.27	21.37	21.37	1.31	23.93	23.93	1.37
70 (21.1)	525	4.84	4.45	7.04	6.47	9.43	8.60	1.18	12.28	10.90	1.24	14.86	13.52	1.31	17.74	17.74	1.38	20.89	20.89	1.48	23.84	23.84	1.55
	600	4.92	4.53	7.15	6.57	9.58	8.74	1.17	12.44	11.04	1.23	15.05	13.70	1.28	18.00	18.00	1.35	21.15	21.15	1.42	23.87	23.87	1.49
	675	4.99	4.59	7.25	6.66	9.71	8.85	1.16	12.56	11.16	1.21	15.21	13.84	1.26	18.21	18.21	1.33	21.20	21.20	1.39	23.75	23.75	1.45
75 (23.9)	525	4.50	4.14	6.70	6.16	9.09	8.29	1.23	11.98	10.64	1.30	14.56	13.25	1.37	17.39	17.39	1.45	20.50	20.50	1.55	23.52	23.52	1.63
	600	4.59	4.22	6.82	6.27	9.24	8.42	1.22	12.15	10.79	1.29	14.75	13.43	1.34	17.65	17.65	1.42	20.82	20.82	1.50	23.58	23.58	1.57
	675	4.66	4.29	6.92	6.36	9.36	8.54	1.22	12.29	10.91	1.27	14.91	13.57	1.33	17.86	17.86	1.39	20.95	20.95	1.46	23.53	23.53	1.52

INDOOR AIR		OUTDOOR COIL ENTERING AIR TEMPERATURES ° F (° C)																					
EDB ° F (° C)	CFM	-3 (-19.4)		7 (-13.9)		17 (-8.3)		27 (-2.8)		37 (2.8)		47 (8.3)		57 (13.9)		67 (19.4)							
		Capacity MBtuh	Total Sys. KWt	Capacity MBtuh	Total Sys. KWt	Capacity MBtuh	Total Sys. KWt	Capacity MBtuh	Total Sys. KWt	Capacity MBtuh	Total Sys. KWt	Capacity MBtuh	Total Sys. KWt	Capacity MBtuh	Total Sys. KWt	Capacity MBtuh	Total Sys. KWt						
65 (18.3)	700	8.38	7.71	11.07	10.18	14.28	13.02	15.2	17.14	15.23	1.57	20.39	18.56	1.63	24.08	24.08	1.72	28.29	28.29	1.86	32.83	32.83	2.02
	800	8.52	7.83	11.24	10.33	14.45	13.17	1.50	17.34	15.40	1.54	20.64	18.79	1.60	24.41	24.41	1.68	28.68	28.68	1.81	32.90	32.90	1.94
	900	8.64	7.95	11.39	10.47	14.59	13.30	1.49	17.50	15.54	1.53	20.85	18.98	1.58	24.67	24.67	1.66	28.96	28.96	1.77	32.79	32.79	1.88
70 (21.1)	700	7.98	7.35	10.69	9.83	13.97	12.74	1.59	16.84	14.96	1.65	20.05	18.24	1.71	23.68	23.68	1.81	27.81	27.81	1.95	32.46	32.46	2.13
	800	8.12	7.47	10.86	9.98	14.15	12.90	1.58	17.04	15.13	1.63	20.30	18.47	1.68	24.00	24.00	1.77	28.21	28.21	1.90	32.56	32.56	2.04
	900	8.24	7.58	11.00	10.11	14.30	13.04	1.57	17.21	15.28	1.61	20.50	18.66	1.66	24.26	24.26	1.74	28.53	28.53	1.87	32.53	32.53	1.98
75 (23.9)	700	7.57	6.97	10.29	9.46	13.23	12.06	1.66	16.55	14.70	1.73	19.70	17.83	1.80	23.28	23.28	1.90	27.36	27.36	2.04	31.99	31.99	2.24
	800	7.71	7.09	10.46	9.61	13.44	12.26	1.65	16.74	14.87	1.71	19.94	18.15	1.77	23.59	23.59	1.86	27.76	27.76	1.99	32.27	32.27	2.15
	900	7.82	7.19	10.60	9.74	13.66	12.45	1.64	16.91	15.02	1.70	20.15	18.33	1.75	23.85	23.85	1.83	28.05	28.05	1.96	32.25	32.25	2.08

See note on pg. 21

HEAT PUMP HEATING PERFORMANCE

INDOOR AIR		OUTDOOR COIL ENTERING AIR TEMPERATURES ° F (° C)																
EDB ° F (° C)	CFM	-3 (-19.4)		7 (-13.9)		17 (-8.3)		27 (-2.8)		37 (2.8)		47 (6.3)		57 (13.9)		67 (19.4)		
		Capacity MBtuh	Total Sys. KWt	Capacity MBtuh	Total Sys. KWt	Capacity MBtuh	Total Sys. KWt	Capacity MBtuh	Total Sys. KWt	Capacity MBtuh	Total Sys. KWt	Capacity MBtuh	Total Sys. KWt	Capacity MBtuh	Total Sys. KWt	Capacity MBtuh	Total Sys. KWt	
		Total	Integ*	Total	Integ*	Total	Integ*	Total	Integ*	Total	Integ*	Total	Integ*	Total	Integ*	Total	Integ*	
25HCC56A30 Outdoor Section With FX4DNF031 Indoor Section																		
65 (18.3)	875	9.76	8.98	13.14	12.08	16.80	15.32	17.3	18.75	1.83	25.07	22.82	1.91	29.50	29.50	34.45	34.45	
	1000	9.94	9.15	13.35	12.27	17.06	15.56	17.3	18.94	1.81	25.37	23.08	1.89	29.87	29.87	34.61	34.61	
	1125	10.10	9.29	13.53	12.44	17.28	15.75	17.3	19.13	1.80	25.61	23.31	1.87	30.18	30.18	34.65	34.65	
70 (21.1)	875	9.22	8.49	12.63	11.61	16.30	14.86	1.82	20.75	18.43	1.92	24.68	22.46	2.01	29.04	29.04	33.93	33.93
	1000	9.40	8.65	12.84	11.80	16.55	15.09	1.81	20.99	18.64	1.90	24.96	22.71	1.98	29.40	29.40	34.27	34.27
	1125	9.56	8.80	13.03	11.97	16.77	15.29	1.81	21.18	18.81	1.89	25.20	22.93	1.97	29.70	29.70	34.31	34.31
75 (23.9)	875	8.65	7.96	12.09	11.11	15.76	14.37	1.90	20.33	18.05	2.01	24.28	22.09	2.11	28.57	28.57	33.39	33.39
	1000	8.83	8.12	12.30	11.30	16.02	14.60	1.90	20.59	18.29	2.00	24.56	22.35	2.08	28.93	28.93	33.82	33.82
	1125	8.98	8.26	12.48	11.47	16.23	14.80	1.90	20.81	18.48	1.99	24.80	22.56	2.06	29.22	29.22	33.98	33.98
OUTDOOR COIL ENTERING AIR TEMPERATURES ° F (° C)																		
INDOOR AIR	EDB ° F (° C)	CFM	-3 (-19.4)		7 (-13.9)		17 (-8.3)		27 (-2.8)		37 (2.8)		47 (6.3)		57 (13.9)		67 (19.4)	
			Capacity MBtuh	Total Sys. KWt	Capacity MBtuh	Total Sys. KWt	Capacity MBtuh	Total Sys. KWt	Capacity MBtuh	Total Sys. KWt	Capacity MBtuh	Total Sys. KWt	Capacity MBtuh	Total Sys. KWt	Capacity MBtuh	Total Sys. KWt	Capacity MBtuh	Total Sys. KWt
			Total	Integ*	Total	Integ*	Total	Integ*	Total	Integ*	Total	Integ*	Total	Integ*	Total	Integ*	Total	Integ*
25HCC56A30 Outdoor Section With FX4DNF037 Indoor Section																		
65 (18.3)	1050	11.44	10.52	15.33	14.09	19.61	17.88	2.15	24.41	21.68	2.26	29.99	27.29	2.39	35.11	35.11	40.74	40.74
	1200	11.66	10.73	15.60	14.34	19.93	18.17	2.15	24.85	22.07	2.24	30.35	27.62	2.36	35.57	35.57	41.14	41.14
	1350	11.86	10.91	15.83	14.55	20.21	18.42	2.15	25.78	22.90	2.25	30.66	27.90	2.34	35.94	35.94	41.32	41.32
70 (21.1)	1050	10.73	9.87	14.64	13.45	18.94	17.26	2.25	23.71	21.05	2.36	29.52	26.86	2.51	34.56	34.56	40.20	40.20
	1200	10.95	10.08	14.91	13.70	19.26	17.56	2.25	24.10	21.41	2.35	29.87	27.19	2.47	35.00	35.00	40.60	40.60
	1350	11.15	10.26	15.15	13.92	19.53	17.81	2.25	24.44	21.70	2.34	30.17	27.46	2.45	35.37	35.37	40.83	40.83
75 (23.9)	1050	9.98	9.19	13.92	12.79	18.23	16.62	2.36	22.97	20.40	2.47	28.97	26.36	2.63	34.00	34.00	39.58	39.58
	1200	10.20	9.38	14.18	13.03	18.55	16.92	2.35	23.37	20.76	2.45	29.35	26.71	2.59	34.43	34.43	39.84	39.84
	1350	10.39	9.55	14.41	13.25	18.82	17.16	2.35	23.70	21.05	2.45	29.66	26.99	2.57	34.80	34.80	40.32	40.32

See note on pg. 21



25HCC5

HEAT PUMP HEATING PERFORMANCE

INDOOR AIR		OUTDOOR COIL ENTERING AIR TEMPERATURES ° F (° C)																							
EDB ° F (° C)	CFM	-3 (-19.4)		7 (-13.9)		17 (-8.3)		27 (-2.8)		37 (2.8)		47 (8.3)		57 (13.9)		67 (19.4)									
		Capacity MBtuh	Total Sys. KWt	Capacity MBtuh	Total Sys. KWt	Capacity MBtuh	Total Sys. KWt	Capacity MBtuh	Total Sys. KWt	Capacity MBtuh	Total Sys. KWt	Capacity MBtuh	Total Sys. KWt	Capacity MBtuh	Total Sys. KWt	Capacity MBtuh	Total Sys. KWt								
65 (18.3)	1225	15.59	14.35	2.29	20.20	18.56	2.45	25.92	23.63	2.65	30.84	27.39	2.83	36.17	32.92	3.00	42.10	42.10	3.16	48.79	48.79	3.32	56.67	56.67	3.45
	1400	15.85	14.58	2.30	20.53	18.87	2.46	26.26	23.95	2.66	31.19	27.70	2.82	36.63	33.33	2.97	42.66	42.66	3.12	49.49	49.49	3.26	57.34	57.34	3.36
	1575	16.10	14.81	2.31	20.82	19.13	2.47	26.55	24.21	2.66	31.50	27.98	2.82	37.01	33.68	2.96	43.12	43.12	3.10	50.13	50.13	3.21	57.72	57.72	3.30
70 (21.1)	1225	14.91	13.71	2.42	19.56	17.97	2.58	24.56	22.39	2.75	30.36	26.97	2.95	35.61	32.40	3.12	41.46	41.46	3.29	48.00	48.00	3.46	55.78	55.78	3.61
	1400	15.19	13.98	2.43	19.88	18.27	2.58	24.93	22.73	2.74	30.71	27.27	2.94	36.05	32.81	3.09	42.00	42.00	3.25	48.69	48.69	3.40	56.54	56.54	3.51
	1575	15.44	14.20	2.45	20.17	18.54	2.59	25.36	23.13	2.75	31.04	27.56	2.93	36.43	33.15	3.08	42.45	42.45	3.22	49.27	49.27	3.37	56.99	56.99	3.45
75 (23.9)	1225	14.21	13.08	2.57	18.88	17.35	2.71	23.85	21.74	2.87	29.87	26.53	3.08	35.07	31.91	3.25	40.82	40.82	3.43	47.26	47.26	3.61	54.86	54.86	3.79
	1400	14.48	13.32	2.58	19.21	17.65	2.71	24.24	22.10	2.87	30.24	26.86	3.06	35.49	32.30	3.22	41.35	41.35	3.38	47.91	47.91	3.55	55.73	55.73	3.68
	1575	14.73	13.55	2.59	19.49	17.91	2.72	24.58	22.41	2.87	30.53	27.11	3.06	35.86	32.63	3.21	41.79	41.79	3.36	48.46	48.46	3.51	56.22	56.22	3.62

INDOOR AIR		OUTDOOR COIL ENTERING AIR TEMPERATURES ° F (° C)																							
EDB ° F (° C)	CFM	-3 (-19.4)		7 (-13.9)		17 (-8.3)		27 (-2.8)		37 (2.8)		47 (8.3)		57 (13.9)		67 (19.4)									
		Capacity MBtuh	Total Sys. KWt	Capacity MBtuh	Total Sys. KWt	Capacity MBtuh	Total Sys. KWt	Capacity MBtuh	Total Sys. KWt	Capacity MBtuh	Total Sys. KWt	Capacity MBtuh	Total Sys. KWt	Capacity MBtuh	Total Sys. KWt	Capacity MBtuh	Total Sys. KWt								
65 (18.3)	1400	16.37	15.06	2.69	21.66	19.90	2.81	27.28	24.87	2.94	34.22	30.39	3.11	40.09	36.48	3.25	46.59	46.59	3.41	54.10	54.10	3.55	61.91	61.91	3.75
	1600	16.66	15.33	2.71	22.01	20.22	2.82	27.68	25.24	2.94	34.60	30.73	3.10	40.55	36.90	3.23	47.23	47.23	3.35	54.62	54.62	3.48	62.33	62.33	3.65
	1800	16.89	15.54	2.74	22.28	20.47	2.85	28.02	25.54	2.95	34.92	31.02	3.10	40.94	37.26	3.22	47.82	47.82	3.32	54.95	54.95	3.44	62.50	62.50	3.59
70 (21.1)	1400	15.67	14.42	2.80	20.94	19.24	2.92	26.53	24.19	3.05	33.62	29.86	3.24	39.50	35.84	3.40	45.90	45.90	3.57	53.35	53.35	3.71	61.09	61.09	3.92
	1600	15.92	14.64	2.82	21.26	19.54	2.93	26.91	24.54	3.06	34.06	30.25	3.23	39.96	36.36	3.37	46.50	46.50	3.52	53.89	53.89	3.64	61.56	61.56	3.83
	1800	16.18	14.88	2.85	21.57	19.82	2.96	27.28	24.87	3.07	34.42	30.57	3.23	40.35	36.72	3.36	47.13	47.13	3.48	54.27	54.27	3.60	61.81	61.81	3.77
75 (23.9)	1400	14.90	13.71	2.92	20.17	18.54	3.04	25.75	23.47	3.18	31.86	28.30	3.34	38.94	35.44	3.55	45.22	45.22	3.72	52.61	52.61	3.88	60.27	60.27	4.10
	1600	15.14	13.93	2.94	20.49	18.83	3.06	26.14	23.83	3.18	32.35	28.73	3.33	39.38	35.84	3.52	45.78	45.78	3.68	53.18	53.18	3.81	60.77	60.77	4.00
	1800	15.40	14.17	2.97	20.80	19.12	3.08	26.50	24.16	3.20	32.86	29.18	3.34	39.76	36.18	3.50	46.33	46.33	3.64	53.56	53.56	3.77	61.07	61.07	3.94

See note on pg. 21

HEAT PUMP HEATING PERFORMANCE CONTINUED

INDOOR AIR		OUTDOOR COIL ENTERING AIR TEMPERATURES ° F (° C)																							
		-3 (-19.4)		7 (-13.9)		17 (-8.3)		27 (-2.8)		37 (2.8)		47 (8.3)		57 (13.9)		67 (19.4)									
EDB ° F (° C)	CFM	Capacity MBtuh		Total Sys. KW†		Capacity MBtuh		Total Sys. KW†		Capacity MBtuh		Total Sys. KW†		Capacity MBtuh		Total Sys. KW†									
		Total	Integ*	Total	Integ*	Total	Integ*	Total	Integ*	Total	Integ*	Total	Integ*	Total	Integ*	Total	Integ*								
25HCC560A30 Outdoor Section With FX4DNF061 Indoor Section																									
65 (18.3)	1750	20.70	19.04	3.28	27.02	24.83	3.42	33.72	30.75	3.56	41.23	36.62	3.72	49.82	45.33	3.93	57.86	57.86	4.12	67.41	67.41	4.34	78.26	78.26	4.58
	2000	21.11	19.43	3.32	27.50	25.28	3.45	34.30	31.27	3.58	42.09	37.39	3.72	50.38	45.85	3.90	58.60	58.60	4.07	68.57	68.57	4.25	79.11	79.11	4.49
	2250	21.49	19.77	3.37	27.92	25.66	3.49	34.77	31.71	3.60	43.47	38.61	3.77	50.91	46.33	3.90	59.23	59.23	4.06	69.29	69.29	4.21	79.67	79.67	4.43
70 (21.1)	1750	19.65	18.07	3.42	26.01	23.91	3.57	32.79	29.90	3.72	40.18	35.69	3.88	49.10	44.68	4.11	57.00	57.00	4.30	66.31	66.31	4.55	77.15	77.15	4.78
	2000	20.06	18.45	3.46	26.49	24.34	3.59	33.34	30.39	3.73	40.83	36.26	3.88	49.67	45.20	4.08	57.72	57.72	4.26	67.32	67.32	4.46	78.01	78.01	4.68
	2250	20.43	18.80	3.50	26.91	24.73	3.63	33.81	30.82	3.76	41.39	36.76	3.89	50.19	45.68	4.08	58.34	58.34	4.24	68.30	68.30	4.40	78.62	78.62	4.63
75 (23.9)	1750	18.54	17.06	3.56	24.96	22.84	3.72	31.79	28.98	3.88	39.14	34.76	4.06	48.41	44.05	4.30	56.16	56.16	4.50	65.21	65.21	4.76	76.04	76.04	4.99
	2000	18.95	17.44	3.60	25.43	23.37	3.75	32.33	29.47	3.90	39.76	35.31	4.05	49.00	44.59	4.27	56.88	56.88	4.45	66.27	66.27	4.66	76.93	76.93	4.89
	2250	19.32	17.77	3.65	25.85	23.76	3.79	32.79	29.90	3.92	40.31	35.80	4.06	49.45	45.00	4.26	57.47	57.47	4.43	67.20	67.20	4.61	77.54	77.54	4.83

NOTE: When the required data falls between the published data, interpolation may be performed. Extrapolation is not an acceptable practice.

* The Btuh heating capacity values shown are net integrated values from which the defrost effect has been subtracted. The Btuh heating from supplement heaters should be added to those values to obtain total system capacity.

† The kW values include the compressor, outdoor fan motor, and indoor blower motor. The kW from supplement heaters should be added to these values to obtain total system kilowatts.

EDB — Entering Dry Bulb

GUIDE SPECIFICATIONS

GENERAL

AIR-COOLED, SPLIT-SYSTEM HEAT PUMP
25HCC5
1-1/2 TO 5 NOMINAL TONS

System Description

Outdoor-mounted, air-cooled, split-system heat pump unit suitable for ground or rooftop installation. Unit consists of a hermetic compressor, an air-cooled coil, propeller-type condenser fan, and a control box. Unit will discharge supply air upward as shown on contract drawings. Unit will be used in a refrigeration circuit to match up to a packaged fan coil or coil unit.

Quality Assurance

- Unit will be rated in accordance with the latest edition of AHRI Standard 240.
- Unit will be certified for capacity and efficiency, and listed in the latest AHRI directory.
- Unit construction will comply with latest edition of ANSI/ASHRAE and with NEC.
- Unit will be constructed in accordance with UL standards and will carry the UL label of approval. Unit will have C-UL approval.
- Unit cabinet will be capable of withstanding Federal Test Method Standard No. 141 (Method 6061) 500-hr salt spray test.
- Air-cooled condenser coils are pressure tested and the outdoor unit is leak tested.
- Unit constructed in ISO9001 approved facility.

Delivery, Storage, and Handling

- Unit will be shipped as single package only and is stored and handled per unit manufacturer's recommendations.

Warranty (for inclusion by specifying engineer)

- U.S. and Canada only.

PRODUCTS

Equipment

- Factory assembled, single piece, air-cooled heat pump unit. Contained within the unit enclosure is all factory wiring, piping, controls, compressor, refrigerant charge Puron® (R-410A), and special features required prior to field start-up.

Unit Cabinet

- Unit cabinet will be constructed of galvanized steel, bonderized, and coated with a powder coat paint.

Fans

- Condenser fan will be direct-drive propeller type, discharging air upward.
- Condenser fan motors will be totally enclosed, 1-phase type with class B insulation and permanently lubricated bearings.
- Shafts will be corrosion resistant.
- Fan blades will be statically and dynamically balanced.
- Condenser fan openings will be equipped with steel wire safety guards.

Compressor

- Compressor will be hermetically sealed.
- Compressor will be mounted on rubber vibration isolators.

Condenser Coil

- Condenser coil will be air cooled.
- Coil will be constructed of aluminum fins mechanically bonded to copper tubes which are then cleaned, dehydrated, and sealed.

Refrigeration Components

- Refrigeration circuit components will include liquid-line shutoff valve with sweat connections, vapor-line shutoff valve with sweat connections, system charge of Puron® (R-410A) refrigerant, POE compressor oil, accumulator, and reversing valve.

Operating Characteristics

- The capacity of the unit will meet or exceed _____ Btuh at a suction temperature of _____ °F/°C. The power consumption at full load will not exceed _____ kW.
- Combination of the unit and the evaporator or fan coil unit will have a total net cooling capacity of _____ Btuh or greater at conditions of _____ CFM entering air temperature at the evaporator at _____ °F wet bulb and _____ °F/°C dry bulb, and air entering the unit at _____ °F/°C.
- The system will have a SEER of _____ Btuh/watt or greater at DOE conditions.

Electrical Requirements

- Nominal unit electrical characteristics will be _____ v, single phase, 60 hz. The unit will be capable of satisfactory operation within voltage limits of _____ v to _____ v.
- Nominal unit electrical characteristics will be _____ v, three phase, 60 hz. The unit will be capable of satisfactory operation within voltage limits of _____ v to _____ v.
- Unit electrical power will be single point connection.
- Control circuit will be 24v.

Special Features

- Refer to section of this literature identifying accessories and descriptions for specific features and available enhancements.

SYSTEM DESIGN SUMMARY

1. Intended for outdoor installation with free air inlet and outlet. Outdoor fan external static pressure available is less than 0.01-in. wc.
2. Minimum outdoor operating air temperature without low-ambient operation accessory is 55°F (12.8°C).
3. Maximum outdoor operating air temperature for cooling mode is 125°F (51.7°C).
4. Minimum outdoor operating air temperature for heating mode is -30°F (-34.4°C).
5. Maximum outdoor operating air temperature for heating mode is 66°F (18.9°C).
6. For reliable operation, unit should be level in all horizontal planes.
7. For interconnecting refrigerant tube lengths greater than 80 ft (23.4 m) and/or elevation differences between indoor and outdoor units greater than 20 ft (6.1 m), consult Residential Piping and Longline Guideline and Service Manual available from equipment distributor.
8. If any refrigerant tubing is buried, provide a 6 in. (152.4 mm) vertical rise to the valve connections at the unit. Refrigerant tubing lengths up to 36 in. (914.4 mm) may be buried without further consideration. Do not bury refrigerant lines longer than 36 in. (914.4 mm).
9. Use only copper wire for electric connection at unit. Aluminum and clad aluminum are not acceptable for the type of connector provided.
10. Do not apply capillary tube indoor coils to these units.
11. Factory-supplied filter drier must be installed.

