

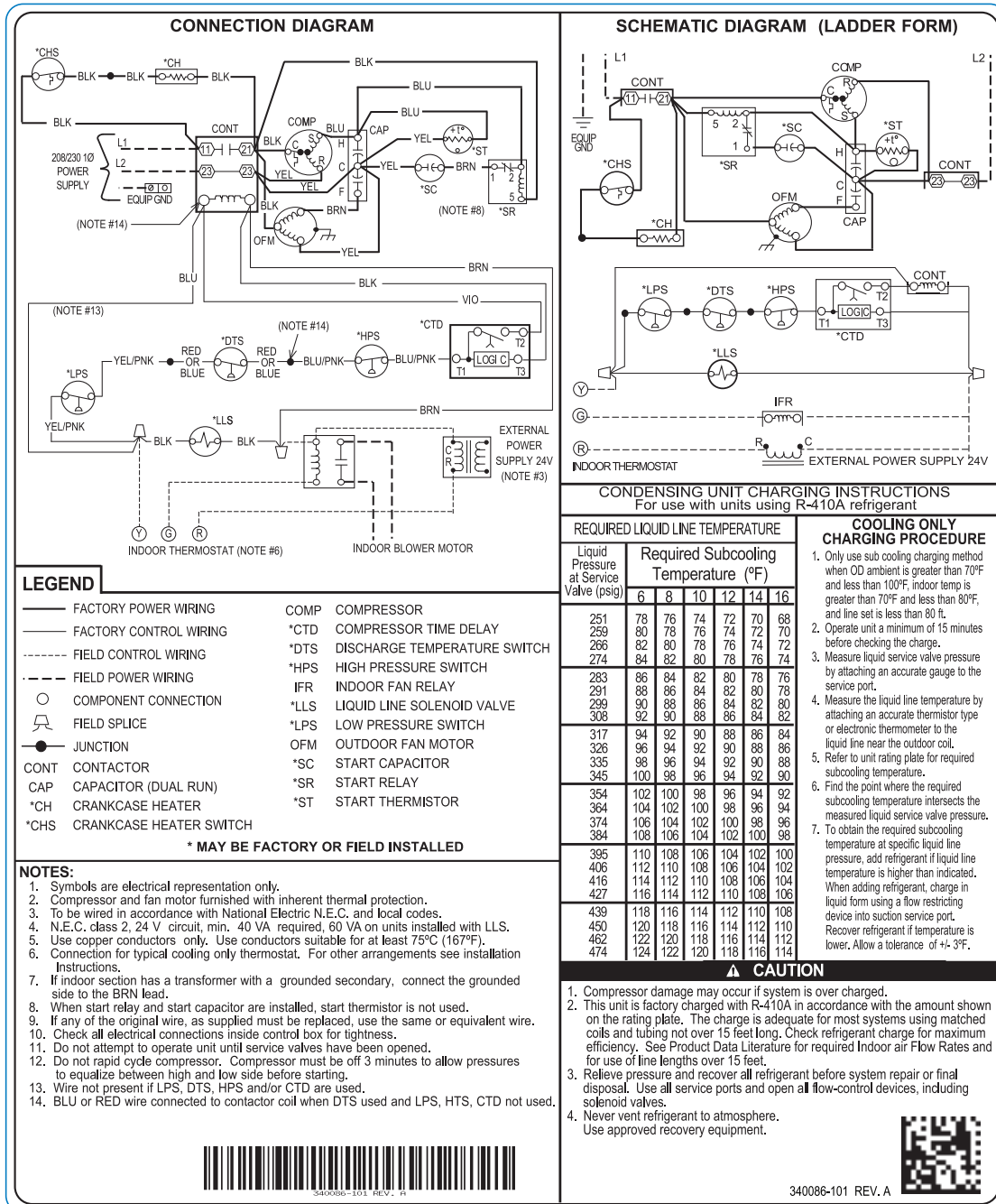

# WIRING DIAGRAM

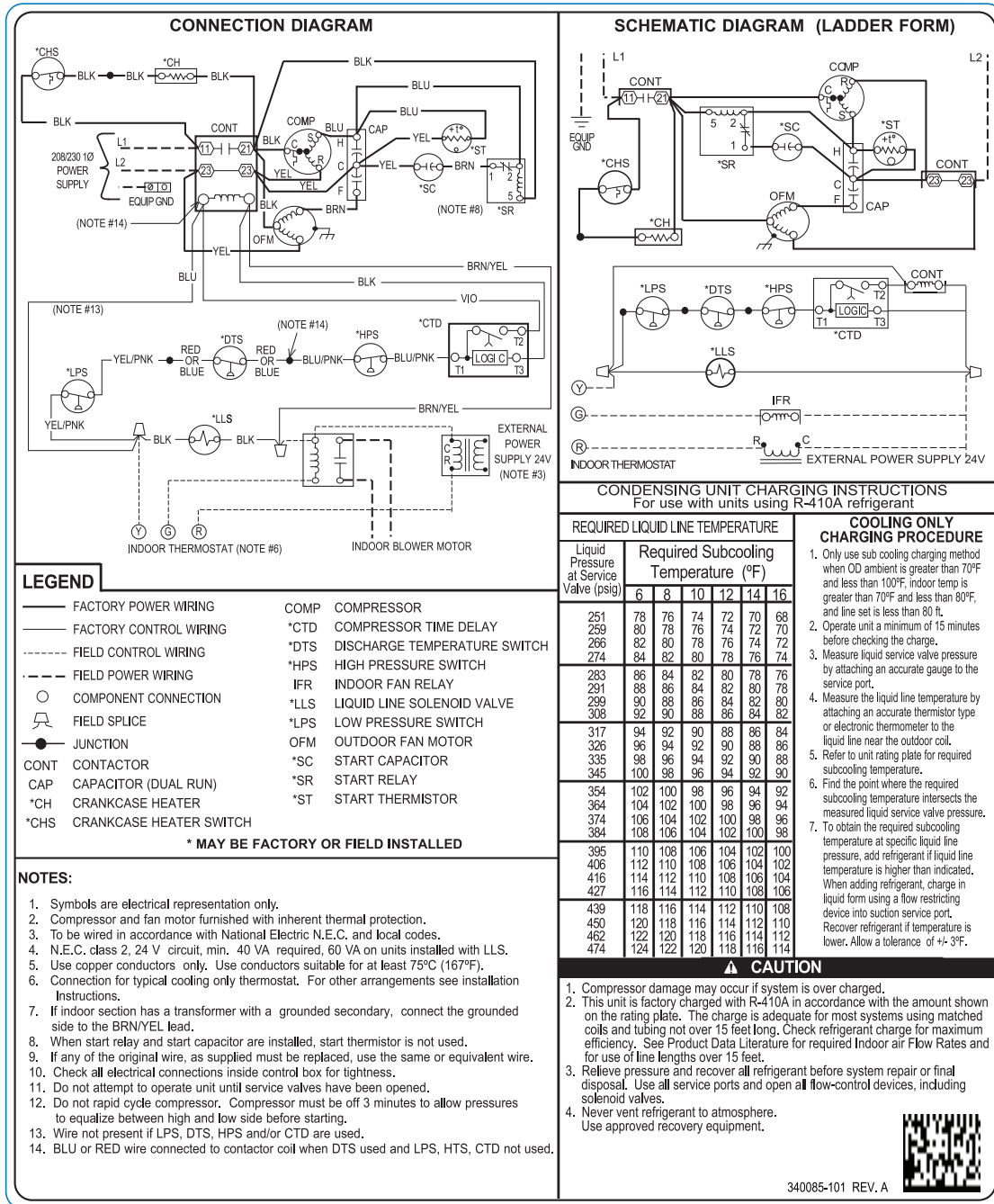

**Fig. 1 – Wiring Diagram — Models BA16N\*018-030 / BA13NA, BA14NA, BA15NA018-060, 208/230-1**



**Fig. 2 – Wiring Diagram — Model BA16NA036-061, BA16NW036-060 208/230-1**

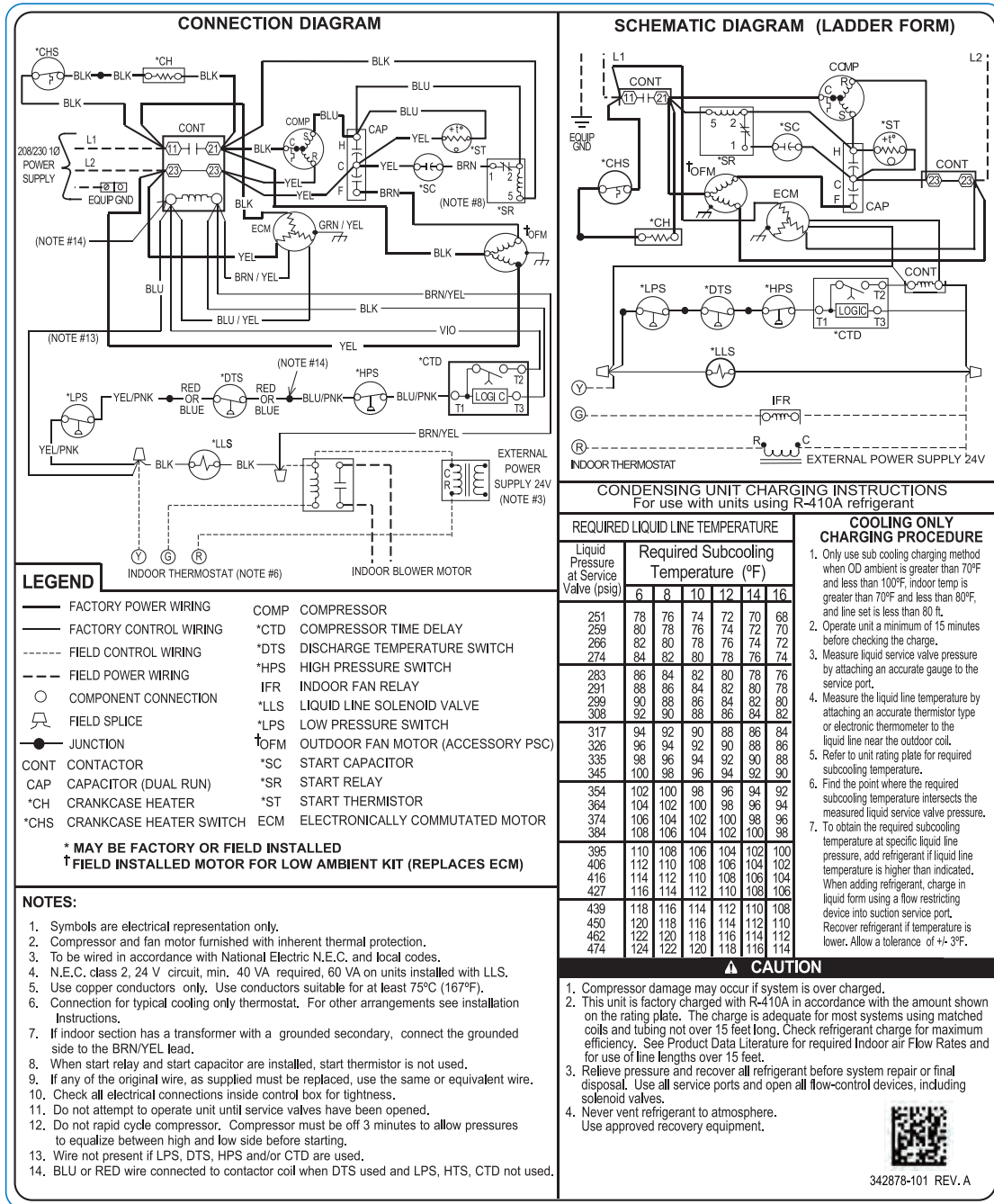

**Fig. 3 – Wiring Diagram — Model BA16NW061, 208/230-1**

