

**INSTALLATION, OPERATING AND MAINTENANCE INSTRUCTIONS  
CENTRIFUGAL SPUN ALUMINUM ROOF VENTILATORS  
MODEL VE — BELT and DIRECT DRIVE**

CARNES COMPANY 448 S. Main St., P. O. Box 930040, Verona, WI 53593-0040 Phone: (608)845-6411 Fax: (608)845-6504 www.carnes.com

**CAUTION!****DO NOT INSTALL, USE OR OPERATE THIS EQUIPMENT UNTIL THIS MANUAL HAS BEEN READ AND UNDERSTOOD. READ AND SAVE THESE SHEETS FOR FUTURE USE.****RECEIVING, HANDLING AND STORAGE**

1. Handle the fan with care. Avoid severe jarring or dropping of the unit.
2. Carefully inspect the unit for damage upon delivery. If the unit has been damaged in transit it is the responsibility of the recipient to make all claims against the carrier.
3. Provide adequate, protected storage prior to installation.

**INSTALLATION**

1. Upon unpacking, inspect the unit for any damage that may have occurred in transit. Check also for loose or missing parts.
2. **CAUTION!** This fan contains rotating parts and requires electrical service. Appropriate safety precautions should be taken during installation, operation and maintenance.
3. **WARNING!** Do not install or operate this fan in an environment or atmosphere where combustible or flammable materials, gasses or fumes are present, unless it has been specifically designed and manufactured for use in that environment. **Explosion** or **Fire** could result.
4. This ventilator requires a minimum of four (4) mounting fasteners, of the appropriate size and type, in order to be securely fastened to the roof curb. Be sure to use an approved sealant or gasket between the fan and curb to prevent leaking and reduce possible vibration.
5. A damper, if used, should be securely mounted in a manner which allows free and unobstructed operation. Fan wiring should not interfere with damper blades.
6. **CAUTION!** All electrical work must be done in accordance with local and/or national electrical code as applicable. If you are unfamiliar with methods of installing electrical wiring, secure the services of a qualified electrician.
7. **WARNING!** This product must be grounded.
8. **DANGER!** Make sure power is turned off and locked in **OFF** position at the service entrance before installing, wiring or servicing fan.
9. **CAUTION!** Before wiring the motor, check the supply voltage against the motor nameplate voltage. High or low voltage can damage the motor and void the warranty.
10. Power should be routed through the conduit openings provided.
11. Access to the motor compartment is possible by either removing the motor cover or motor tube/motor cover assembly.
12. **WARNING!** Be sure to keep all wiring clear of rotating or moving parts.
13. **WARNING!** Before starting the fan, turn the wheel to assure it rotates freely. If needed, adjust the wheel/shaft bearing/motor position as required to achieve necessary clearances.
14. **CAUTION!** On belt drive units assure belts are tensioned and aligned properly. (See Maintenance section).
15. **WARNING!** Check all set screws and keys, tighten as necessary prior to fan start up. **DO NOT** over torque.
16. Remount motor cover/tube, do not over torque fasteners (30 in. - lb. maximum).

## **OPERATION**

1. **CAUTION!** Check that the fan inlet/ductwork/exhaust openings are clean and free of obstructions. Poor inlet conditions will result in seriously reduced fan performance.
2. **WARNING!** This fan contains rotating parts. Appropriate safety precautions should be taken during operation.
3. Operate under power and check for correct wheel rotation direction (clockwise when looking at top of the wheel).
4. **CAUTION!** Incorrect rotation can damage the fan motor and seriously impede fan operation.

## **MAINTENANCE**

1. **DANGER!** Before performing and maintenance on the fan, be sure power is turned off and locked in the **OFF** position at the service entrance before servicing the fan.
2. Ventilators should be carefully checked at least once a year. For critical or rugged applications, a routine check every two or three months is suggested.
3. All motors supplied with CARNES ventilators carry a one year warranty from date of shipment. For repairs within the warranty period, the motor must be taken to the motor manufacturer's authorized service dealer. Contact your CARNES representative for additional warranty details.
4. Access to the motor compartment is possible by removing the motor cover or motor cover/motor tube assembly.
5. A periodic motor check should consist of spinning the motor shaft with the power off to be sure the motor turns freely and the bearings run smoothly. The belt on belt driven units should be removed from the motor sheave.
6. **CAUTION!** When removing or installing a belt, do not force the belt over the sheave. Loosen the motor mount so that the belt can be easily slipped over the sheave.
7. The belt on belt driven units should be removed and carefully checked for radial cracks, ply separation or irregular wear. A small irregularity in the contact surface of the belt will result in noisy operation. If any of these defects are apparent, the belt should be replaced. Check the sheave also for chipping, dents or rough surfaces which could damage the belt.
8. **CAUTION!** The correct belt tension is important. Too tight a belt will result in excess bearing pressure on the motor bearings and shaft pillow blocks, and may also overload the motor. Too loose a belt will result in slippage which will quickly "burn" out belts. A belt should feel "live" when thumped, approximately 1/4" belt deflection when subjected to finger pressure (3 to 5 lbs.) at midpoint between sheaves.
9. **CAUTION!** The belt alignment should also be checked to be sure the belt is running perpendicular to the rotating shafts. Motor and drive shafts must be parallel. Improper alignment will result in excessive belt wear.

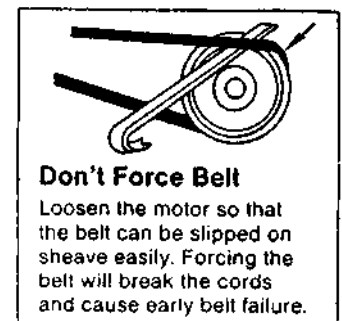
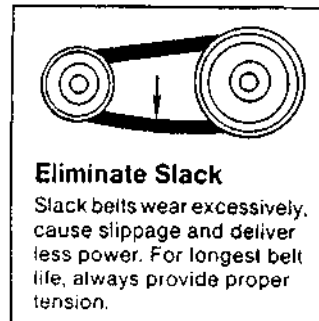
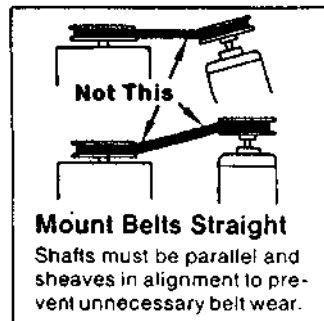

10. **CAUTION!** Check sheave set screws to ensure tightness. Proper keys must be in keyways.
11. **CAUTION!** Do not readjust variable pitch sheave without checking motor amps. Do not readjust variable pitch sheaves above the maximum catalog RPM for unit and motor. If fixed sheaves are replaced, use only sheaves of identical size and type.
12. **CAUTION!** If adjustment of two groove variable pitch sheaves is required, each sheave must be opened or closed the same number of turns. Improper adjustment can cause excessive belt wear and premature failure.

13. If unit is to be left idle for an extended period (especially over summer months), it is recommended that belts be removed and stored in a cool, dry place to avoid premature belt failure.
14. The standard pillow block bearings on CARNES belt driven ventilators are permanently lubricated and are supplied with an oil base corrosion preventive compound. These should not require any service except that during the first few months of operation it is recommended the set screws holding the shaft be checked to be sure they are tight. (Proper tightness will permanently deform All wrench.)
15. The centrifugal fan when should not require maintenance except for removing foreign materials that may accumulate on the blades. The balance weights should not be disturbed. If a wheel has to be removed from the shaft, do not apply force that will damage the bearings or warp the wheel. Use a wheel puller.
16. Access to the wheel for alignment purposes can be obtained by removing the motor lid and/or motor tube. Lateral adjustment is made with the motor mount. Vertical adjustment is made at the bearings.
17. Should it be necessary to remove the wheel, access is through the fan plate. Do not remove the motor/motor mount assembly. Carefully support the motor/motor mount assembly and remove all the fan plate fasteners. Carefully remove the entire assembly from the unit base. To rebuild, assemble in reverse order.

DIMENSIONS LISTED IN INCHES				
UNIT SIZE	INSIDE CURB CAP	ROOF OPENING	WIRING	
			A	B
06	15-1/2	11	2-13/16	4-1/16
08	15-1/2	11	2-13/16	4-1/16
10	17-5/8	13	3-1/2	3-1/2
12	17-6/8	13	3-1/2	3-1/2
15	20-1/2	16	4-7/16	3-7/16
18	25	20-1/2	7-7/8	3-1/4
21	28-1/8	23-1/2	5-13/32	3-19/32
24	31-1/8	26-1/2	6-7/32	3-7/16
30	40-1/8	35-1/2	4-31/32	10-11/32
36	46-1/8	41-1/2	3-21/32	14-27/32
42	54-1/8	49-1/2	3-1/8	19-3/4
48	58-1/2	64-1/8	3-1/8	25-1/8
54	64-1/8	59-1/2	7-3/4	14

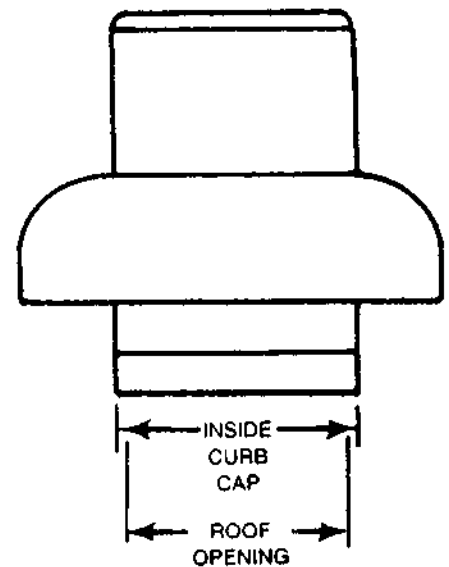

**Conduit Hole Location**

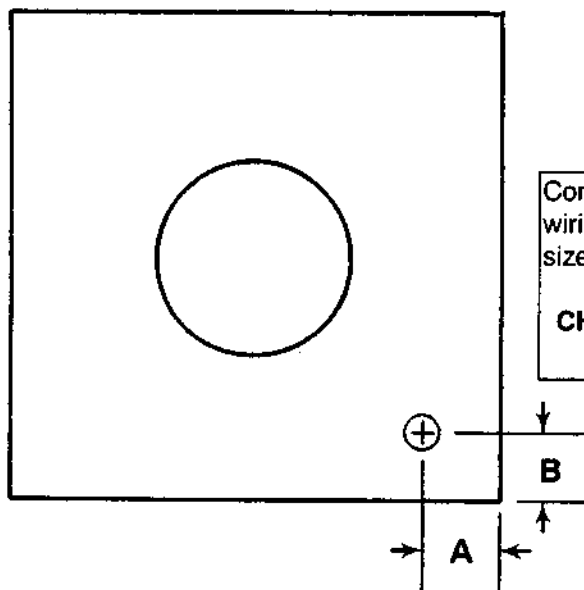

Conduit/Wiring Chase is factory installed through the curb cap for wiring through the roof opening. Conduit is 1" diameter for unit sizes 06 through 19 and 1-1/4" for sizes 21 through 54.

**CHECK WITH LOCAL CODES FOR WIRING REQUIREMENTS**

Fan Cap View from Below

# MODEL VEDK - DIRECT DRIVE - PARTS LIST

VEDK 06 - 18

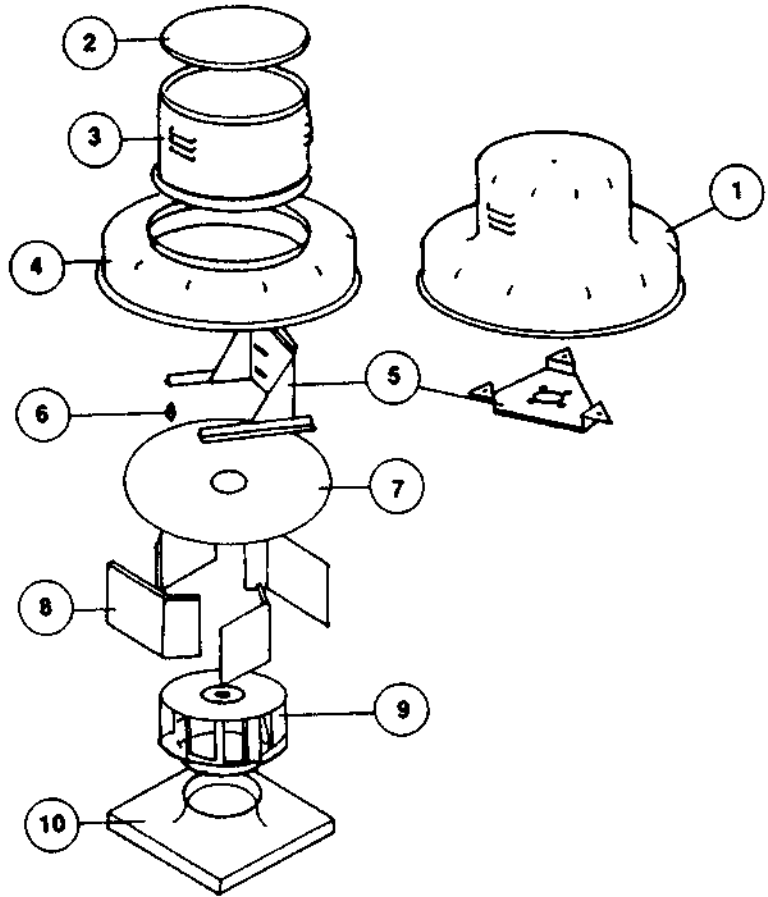

UNIT SIZES	MOTOR TYPE	UNIT CONSTRUCTION	
		STANDARD	EXTENDED
06 - 18	ODP, 1 Speed	ALL	
	OTHERS		ALL

Other motor types include:  
 2 Speed  
 Totally Enclosed  
 Explosion Proof

## STANDARD

UNIT SIZE	MOTOR COVER				MOTOR MOUNT ASSEMBLY	VIBRATION ISOLATORS	FAN PLATE	DIFFUSERS (Set of 4)	WHEEL (Bore Size)				CURB CAP
	ONE PIECE	LID	TUBE	FAN SHROUD					5/16	1/2	5/8	7/8	
06	384-6161	—	—	—	632-0070	(3) 998-6126	384-6101	384-2451	384-0541	384-0542	384-0543	—	384-2401
08	384-6161	—	—	—	632-0070	(3) 998-6126	384-6101	384-2452	384-0545	384-0546	384-0547	—	384-2401
10	384-6162	—	—	—	384-0661	(4) 998-6126	384-6102	384-2453	384-0549	384-0550	384-0551	—	384-2402
12	384-6162	—	—	—	384-0661	(4) 998-6126	384-6102	384-2454	—	384-0553	384-0554	384-0556	384-2402
15	—	384-6522	384-6175	384-6133	384-0663	(4) 998-6126	384-6103	384-2455	—	384-0557	384-0558	384-0560	384-2403
18	—	384-6523	384-6178	384-6134	384-0665	(4) 998-6126	384-6104	384-2456	—	384-0561	384-0562	384-0564	384-2404

## EXTENDED

UNIT SIZE	MOTOR COVER			MOTOR MOUNT ASSEMBLY	VIBRATION ISOLATORS (4 Req'd)	FAN PLATE	DIFFUSERS (Set of 4)	WHEEL (Bore Size)			CURB CAP
	LID	TUBE	FAN SHROUD					1/2	5/8	7/8	
06	384-6521	384-6173	384-6131	384-0661	998-6126	384-6101	384-2451	384-0542	384-0543	—	384-2401
08	384-6521	384-6173	384-6131	384-0661	998-6126	384-6101	384-2452	384-0546	384-0547	—	384-2401
10	384-6521	384-6173	384-6132	384-0661	998-6126	384-6102	384-2453	384-0550	384-0551	—	384-2402
12	384-6521	384-6173	384-6132	384-0661	998-6126	384-6102	384-2454	384-0553	384-0554	384-0556	384-2402
15	384-6522	384-6176	384-6133	384-0663	998-6126	384-6103	384-2455	384-0557	384-0558	384-0560	384-2403
18	384-6523	384-6179	384-6134	384-0665	998-6126	384-6104	384-2456	384-0561	384-0562	384-0564	384-2404

# MODEL VEBK - BELT DRIVE - PARTS LIST

Unit Size	Volt Code	Motor Type	Unit Construction	
			Standard	Extended
06-18	A,B,D	1	1/2 HP & Lower	3/4 HP & Higher
		2	1/4 HP & Lower	1/3 HP & Higher
		5	1/3 HP & Lower	1/2 HP & Higher
		6	ALL	
C,E,G,H	1,5,8,9	3/4 HP & Lower	1 HP & Higher	
	2,6,7	ALL		
21-24	A,B,D	1,2,5,6	ALL	
	C,E,G,H	1,5,7,8,9	5 HP & Lower	7-1/2 HP & Higher
		2,6	2 HP & Lower	3 HP & Higher
30-54	A,B,D	1,2,5,6	ALL	
	C,E,G,H	1,5,7,8,9	5 HP & Lower	7-1/2 HP & Higher
		2,6	2 HP & Lower	3 HP & Higher

Motor Type	Volt Code
1 = ODP	A = 115 1ø
2 = 2 Spd. 2 Winding	B = 208 1ø
5 = TE	C = 208 3ø
6 = Exp. Proof	D = 230 1ø
7 = 2 Spd. 1 Winding	E = 230 3ø
8 = ODP High Eff.	G = 460 3ø
9 = TE High Eff.	H = 575 3ø

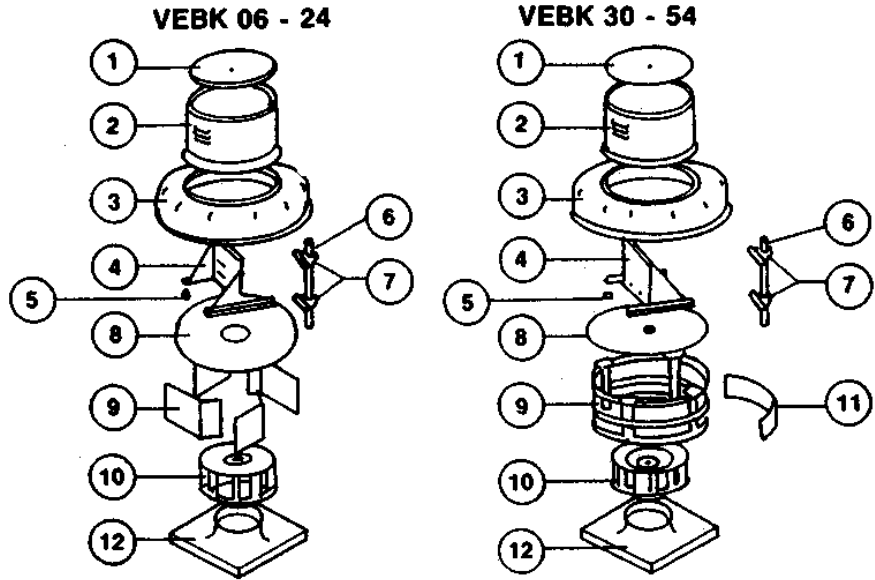

## STANDARD

Unit Size	Motor Cover					Fan 6 Shaft	Pillow 7 Block Bearings (2 Req'd)	Fan 8 Plate	Diffusers 9 (Set of 4) / Support Frame	Std. 10 Wheel	Wind 11 Band (Pieces)	Curb 12 Cap
	LID 1	Tube 2	Fan 3 Shroud	Motor 4 Mount Assem'y	Vibration 5 Isolator (4 Req'd)*							
06	384-6521	384-6172	384-6131	384-0661	998-6126	998-5421	999-8606	384-6101	384-2451	384-0544	--	384-2401
08	384-6521	384-6172	384-6131	384-0661	998-6126	998-5421	999-8606	384-6101	384-2452	384-0548	--	384-2401
10	384-6521	384-6172	384-6132	384-0661	998-6126	998-5421	999-8606	384-6102	384-2453	384-0552	--	384-2402
12	384-6521	384-6172	384-6132	384-0661	998-6126	998-5421	999-8606	384-6102	384-2454	384-0555	--	384-2402
15	384-6522	384-6175	384-6133	384-0663	998-6126	998-5421	999-8606	384-6103	384-2455	384-0559	--	384-2403
18	384-6523	384-6178	384-6134	384-0665	998-9748	998-5421	999-8606	384-6104	384-2456	384-0563	--	384-2404
21	384-6524	384-6180	384-6135	384-0667	999-9748	998-5423	999-8637	384-6105	384-2457	384-0565	--	384-2405
24	384-6525	384-6182	384-6136	384-0669	999-9748	998-5423	999-8637	384-6106	384-2458	384-0566	--	384-2406
30	384-6526	384-6201	384-6137	384-0646	999-9748	998-5435	999-8632	384-6111	384-0521	384-0636	(2) 384-2591	384-2421
36	384-6527	384-6203	384-6138	384-0648	999-9748	998-5427	999-8633	384-6112	384-0522	384-0637	(2) 384-2592	384-2423
42	384-6528	384-6205	384-6139	384-0651	999-9748	998-5429	999-8634	384-6121	384-0526	384-0638	(2) 384-2593	384-2431
48	384-6528	384-6205	384-6140	384-0651	999-9748	998-5429	999-8634	384-6122	384-0527	384-0639	(2) 384-2594	384-2433
54	384-6528	384-6205	384-6141	384-0651	999-9748	998-5431	999-8634	384-6123	384-0531	384-0640	(2) 384-2595	384-2435

## EXTENDED

Unit Size	Motor Cover					Fan 6 Shaft	Pillow 7 Block Bearings (2 Req'd)	Fan 8 Plate	Diffusers 9 (Set of 4) / Support Frame	Std. 10 Wheel	Wind 11 Band (Pieces)	Curb 12 Cap
	LID 1	Tube 2	Fan 3 Shroud	Motor 4 Mount Assem'y	Vibration 5 Isolator (4 Req'd)*							
06	384-6521	384-6173	384-6131	384-0662	998-6126	998-5422	999-8606	384-6101	384-2451	384-0544	--	384-2401
08	384-6521	384-6173	384-6131	384-0662	998-6126	998-5422	999-8606	384-6101	384-2452	384-0548	--	384-2401
10	384-6521	384-6173	384-6132	384-0662	998-6126	998-5422	999-8606	384-6102	384-2453	384-0552	--	384-2402
12	384-6521	384-6173	384-6132	384-0662	998-6126	998-5422	999-8606	384-6102	384-2454	384-0555	--	384-2402
15	384-6522	384-6176	384-6133	384-0664	998-6126	998-5422	999-8606	384-6103	384-2455	384-0559	--	384-2403
18	384-6523	384-6179	384-6134	384-0666	998-9748	998-5422	999-8606	384-6104	384-2456	384-0563	--	384-2404
21	384-6524	384-6181	384-6135	384-0668	999-9748	998-5424	999-8637	384-6105	384-2457	384-0565	--	384-2405
24	384-6525	384-6183	384-6136	384-0670	999-9748	998-5424	999-8637	384-6106	384-2458	384-0566	--	384-2406
30	384-6526	384-6202	384-6137	384-0647	999-9748	998-5426	999-8632	384-6111	384-0521	384-0636	(2) 384-2591	384-2421
36	384-6527	384-6204	384-6138	384-0649	999-9748	998-5428	999-8633	384-6112	384-0522	384-0637	(2) 384-2592	384-2423
42	384-6528	384-6206	384-6139	384-0652	999-9748	998-5430	999-8634	384-6121	384-0526	384-0638	(2) 384-2593	384-2431
48	384-6528	384-6206	384-6140	384-0652	999-9748	998-5430	999-8634	384-6122	384-0527	384-0639	(2) 384-2594	384-2433
54	384-6528	384-6206	384-6141	384-0652	999-9748	998-5432	999-8634	384-6123	384-0531	384-0640	(2) 384-2595	384-2435

\*Sizes 42, 48, 54 get (5) Vibration Isolators.

# TYPICAL INSTALLATIONS

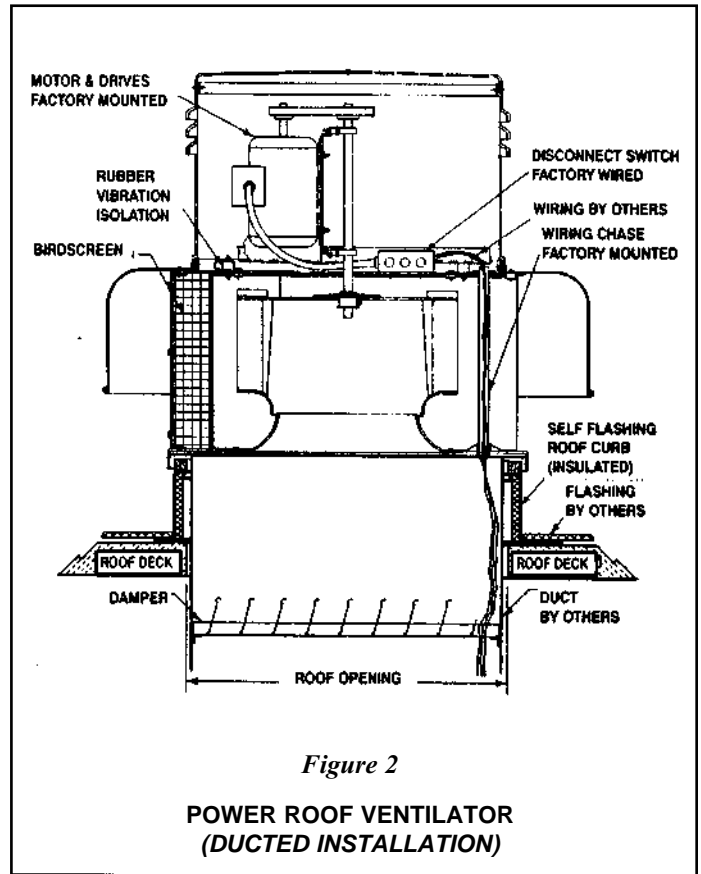
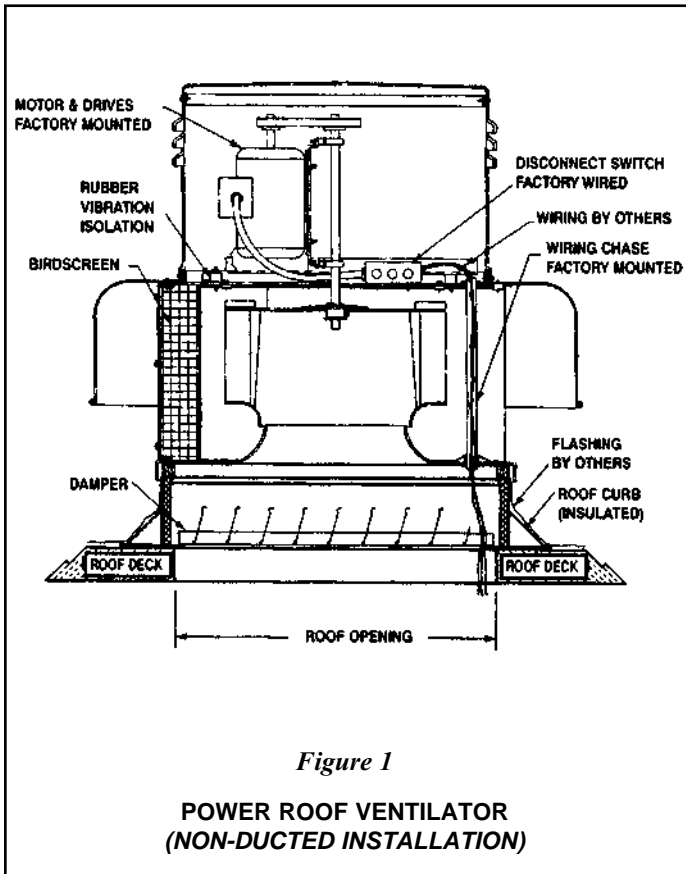

Figure 1 shows a typical Model VEBK power roof ventilator installation without duct work. The roof flashing is shown installed over standard canted style roof curb. A gravity operated backdraft damper is shown installed on the damper shelf which is located at the base of the roof curb. Power wiring is extended through the roof opening, through the damper conduit knockout, into the fan wiring chase and to the factory wired disconnect switch.

Figure 2 shows a typical Model VEBK power roof ventilator installation with an exhaust duct. The duct is shown extending through the roof opening and inside a typical self flashing style roof curb. A gravity operated backdraft damper is shown fastened to a 3/4" x 3/4" sheetmetal angle installed inside the exhaust duct.

Proper fan performance requires uniform and stable airflow at the fan inlet. Avoid transitions, obstructions, elbows or other duct fittings near the fan inlet.

Typical roof curb height is 8" to 12" above the roof deck. Additional height reduces the likelihood of snow or rain entering through the roof opening.

Installation and electrical work should be performed by qualified personnel and must be in accordance with all applicable code requirements.

For protection of personnel, inlet guards are recommended when the fan is within reach (or within 7 feet) of occupied areas or work areas.

**CARNES<sup>®</sup>**  
COMPANY

448 South Main Street  
P. O. Box 930040  
Verona, WI  
53593-0040

Phone: 608/845-6411  
Fax: 608/845-6504  
E Mail: [carnes@carnes.com](mailto:carnes@carnes.com)  
[www.carnes.com](http://www.carnes.com)