

**INSTALLATION, OPERATING AND MAINTENANCE INSTRUCTIONS  
CENTRIFUGAL UPBLAST ROOF EXHAUSTERS FOR  
HIGH TEMPERATURE AND SMOKE CONTROL APPLICATIONS  
MODEL VQBL - BELT DRIVEN**

CARNES COMPANY 448 S. Main St., P. O. Box 930040, Verona, WI 53593-0040 Phone: (608)845-6411 Fax: (608)845-6504 www.carnes.com

**CAUTION!**

**DO NOT INSTALL, USE OR OPERATE THIS EQUIPMENT UNTIL THIS  
MANUAL HAS BEEN READ AND UNDERSTOOD. READ AND SAVE THESE INSTRUCTIONS FOR FUTURE USE.**

**RECEIVING, HANDLING AND STORAGE**

1. Handle the fan with care. Avoid severe jarring or dropping of the unit.
2. Carefully inspect the unit for damage upon delivery. If the unit has been damaged in transit it is the responsibility of the recipient to make all claims against the carrier.
3. Provide adequate, protected storage prior to installation.

**INSTALLATION**

1. Upon unpacking, inspect the unit for any damage that may have occurred in transit. Check also for loose or missing parts.
2. **CAUTION!** This fan contains rotating parts and requires electrical service. Appropriate safety precautions should be taken during installation, operation and maintenance.
3. **WARNING!** Do not install or operate this fan in environment or atmosphere where combustible or flammable materials, gasses or fumes are present, unless it has been specifically designed and manufactured for use in that environment. **Explosion or Fire** could result!
4. This ventilator requires a minimum of four (4) mounting fasteners, of the appropriate size and type in order to be securely fastened to the roof curb. Be sure to use an approved sealant between the fan and curb to prevent leaking.
5. **CAUTION!** All electrical work must be done in accordance with local and/or national electrical code as applicable. If you are unfamiliar with methods of installing electrical wiring, secure the services of a qualified electrician.
6. **WARNING!** This product must be grounded.
7. **DANGER!** Make sure power is turned off and locked in the **OFF** position at the service entrance before installing, wiring or servicing fan.
8. **CAUTION!** Before wiring the motor, check the supply voltage against the motor nameplate voltage. High or low voltage can damage the motor and void the motor warranty.
9. Power should be routed through the conduit openings provided.
10. Access to the motor compartment is possible by either removing the motor cover or motor tube/motor cover assembly.
11. **WARNING!** Be sure to keep all wiring clear of rotating or moving parts.
12. **WARNING!** Before starting the fan, turn the wheel to assure it rotates freely. If needed, adjust the wheel/shaft/bearing/motor position as required to achieve necessary clearances.
13. **CAUTION!** On belt drive units assure belts are tensioned and aligned properly. (See Maintenance section.)
14. **WARNING!** Check all set screws and keys. Tighten as necessary prior to fan startup. Do not over torque.
15. Remount motor cover/motor tube, do not over torque fasteners (30 in. - lb. maximum)

## OPERATION

1. **CAUTION!** Check that the fan inlet/ductwork/exhaust openings are clean and free of obstructions. Poor inlet conditions will result in seriously reduced fan performance.
2. **WARNING!** This fan contains rotating parts. Appropriate safety precautions should be taken during operation.
3. Operate under power and check for correct wheel rotation direction (clockwise when looking at top of the wheel).
4. **CAUTION!** Incorrect rotation can damage the fan motor and seriously impede fan operation.

## MAINTENANCE

1. **DANGER!** Before performing and maintenance on the fan, be sure power is turned off and locked in the **OFF** position at the service entrance before servicing the fan.
2. Ventilators should be carefully checked at least once a year. For critical or rugged applications, a routine check every two or three months is suggested.
3. All motors supplied with CARNES ventilators carry a one year warranty from date of shipment. For repairs within the warranty period, the motor must be taken to the motor manufacturer's authorized service dealer. Contact your CARNES representative for additional warranty details.
4. Access to the motor compartment is possible by removing the motor cover or motor cover/motor tube assembly.
5. A periodic motor check should consist of spinning the motor shaft with the power off to be sure the motor turns freely and the bearings run smoothly. The belt on belt driven units should be removed from the motor sheave.
6. **CAUTION!** When removing or installing a belt, do not force the belt over the sheave. Loosen the motor mount so that the belt can be easily slipped over the sheave.
7. The belt on belt driven units should be removed and carefully checked for radial cracks, ply separation or irregular wear. A small irregularity in the contact surface of the belt will result in noisy operation. If any of these defects are apparent, the belt should be replaced. Check the sheave also for chipping, dents or rough surfaces which could damage the belt.
8. **CAUTION!** The correct belt tension is important. Too tight a belt will result in excess bearing pressure on the motor bearings and shaft pillow blocks, and may also overload the motor. Too loose a belt will result in slippage which will quickly "burn" out belts. A belt should feel "live" when thumped, approximately 1/4" belt deflection when subjected to finger pressure (3 to 5 lbs.) at midpoint between sheaves.
9. **CAUTION!** The belt alignment should also be checked to be sure the belt is running perpendicular to the rotating shafts. Motor and drive shafts must be parallel. Improper alignment will result in excessive belt wear.

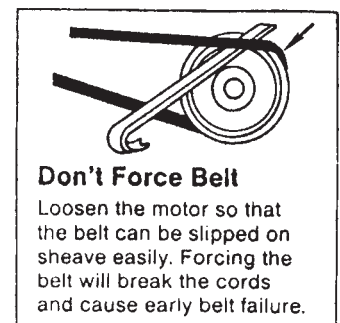
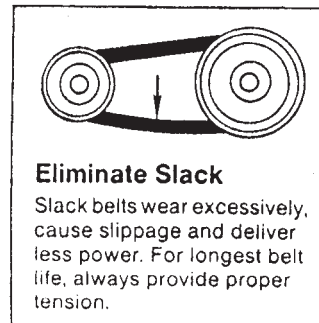
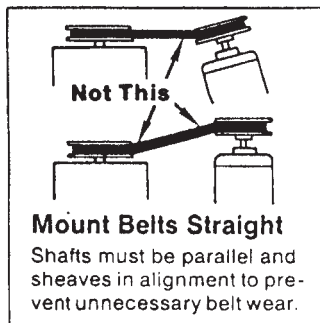

10. **CAUTION!** Check sheave set screws to ensure tightness. Proper keys must be in keyways.
11. **CAUTION!** Do not readjust variable pitch sheave without checking motor amps. Do not readjust variable pitch sheaves above the maximum catalog RPM for unit and motor. If fixed sheaves are replaced, use only sheaves of identical size and type.
12. **CAUTION!** If adjustment of two groove variable pitch sheaves is required, each sheave must be opened or closed the same number of turns. Improper adjustment can cause excessive belt wear and premature failure.

13. If unit is to be left idle for an extended period (especially over summer months), it is recommended that belts be removed and stored in a cool, dry place to avoid premature belt failure.
14. The standard pillow block bearings on CARNES belt driven ventilators are permanently lubricated and are supplied with an oil base corrosion preventive compound. These should not require any service, except that during the first few months of operation it is recommended the set screws holding the shaft be checked to be sure they are tight. (Proper tightness will permanently deform Allen wrench).
15. The centrifugal wheel should not require maintenance except for removing foreign materials that may accumulate on the blades. The balance weights should not be disturbed. If a wheel has to be removed from the shaft, **do not apply force** that will damage the bearings or warp the wheel. Use a wheel puller.
16. Access for wheel alignment purposes can be obtained by removing the motor lid and/or motor tube. Lateral adjustment is made with the motor mount. Vertical adjustment is made at the bears.
17. Should it be necessary to remove the wheel, access is through the fan plate. Do not remove the motor/motor mount assembly. Carefully support the motor/motor mount assembly and remove all the fan plate fasteners. Carefully remove the entire assembly from the unit base. To rebuild, assemble in reverse order.

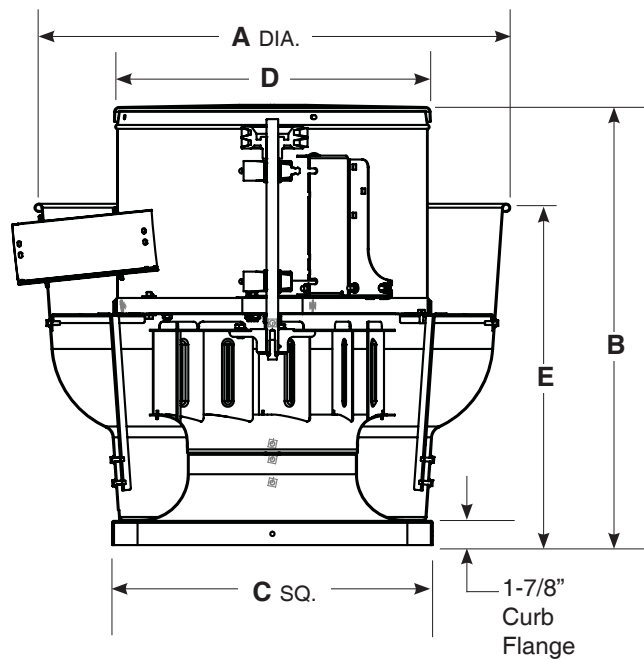

DIMENSIONS (Inches)								
Size	A	B	C Curb Cap (Inside)	D	E	Roof Opening	Curb Outside Dimension	Unit Wt. (Lbs.)
06	26-1/4	22-1/4	15-1/2	20	16-1/4	11	15	105
08	26-1/4	23	15-1/2	20	16-1/4	11	15	105
10	28	28	17-1/2	20	19	13	17	110
12	28	28	17-1/2	20	19	13	17	110
15	30	28-1/2	20-1/2	20	22	16	20	115
18	37-1/2	31-1/2	25	24	23	20-1/2	24-1/2	125

# MODEL VQBL— BELT DRIVE - PARTS LIST

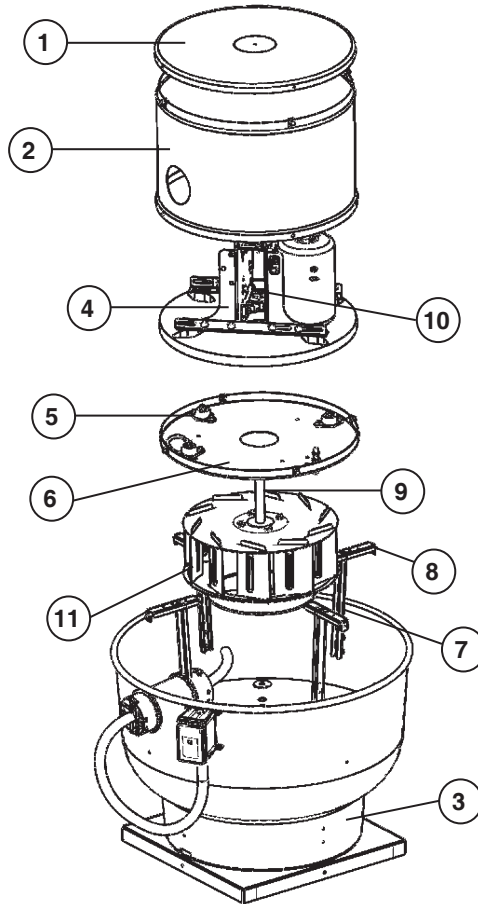

## STANDARD CONSTRUCTION

Unit Size	Motor Cover		Shroud/CC Assembly 3	Motor Mounts 4	Vibration Isolator 5	Fan Plate 6	Vertical Support 7	Horizontal Support 8	Fan Shaft 9	Mounted Bearings 10	Wheel 11
	Lid 1	Tube 2									
06	384-6521	384-6503	386-0500	386-0310	<a href="tel:999-9748">999-9748</a>	386-0186	386-0139	386-0160	998-5451	999-8610	386-0380
08	384-6521	384-6503	386-0501	386-0311	<a href="tel:999-9748">999-9748</a>	386-0186	386-0140	386-0160	998-5451	999-8610	386-0381
10	384-6521	384-6503	386-0502	386-0312	<a href="tel:999-9748">999-9748</a>	386-0186	386-0140	386-0161	998-5451	999-8610	386-0382
12	384-6521	384-6503	386-0503	386-0313	<a href="tel:999-9748">999-9748</a>	386-0186	386-0141	386-0161	998-5451	999-8610	386-0383
15	384-6521	384-6503	386-0504	386-0314	<a href="tel:999-9748">999-9748</a>	386-0186	386-0142	386-0161	998-5451	999-8610	386-0384
18	384-6522	384-6506	386-0505	386-0315	<a href="tel:999-9748">999-9748</a>	386-0187	386-0143	386-0162	998-5452	999-8611	386-0385

**CARNES**<sup>®</sup>  
COMPANY

448 South Main Street  
P. O. Box 930040  
Verona, WI  
53593-0040

Phone: 608/845-6411  
Fax: 608/845-6504  
Email: [carnes@carnes.com](mailto:carnes@carnes.com)  
[www.carnes.com](http://www.carnes.com)