



**IMPORTANT FOR FUTURE REFERENCE**  
Please complete this information and retain this manual for the life of the equipment:

Model #: \_\_\_\_\_  
Serial #: \_\_\_\_\_  
Date Purchased: \_\_\_\_\_

## Installation & Operation Manual

# Direct Steam Compartment Cookers DC-2, DC-3, DDA-2, DDA-3, DCL-2, DCL-3, DCP-2, DCP-3, DCW-2 & DCW-3



Model DC-2



Model DCP-3



Model DDA-2

### **WARNING**

Improper installation, adjustment, alteration, service or maintenance can cause property damage, injury or death. Read the installation, operating and maintenance instructions thoroughly before installing or servicing this equipment.

### **CROWN FOOD SERVICE EQUIPMENT**

 **MIDDLEBY** A Middleby Company

70 Oakdale Road, Downsview (Toronto) Ontario, Canada, M3N 1V9



Telephone: 919-762-1000

[www.crownsteamgroup.com](http://www.crownsteamgroup.com)

# SAFETY PRECAUTIONS

Before installing and operating this equipment, be sure everyone involved in its operation is fully trained and aware of precautions. Accidents and problems can be caused by failure to follow fundamental rules and precautions.

The following symbols, found throughout this manual, alert you to potentially dangerous conditions to the operator, service personnel, or to the equipment.

 <b>DANGER</b>	This symbol warns of immediate hazards that will result in severe injury or death.
 <b>WARNING</b>	This symbol refers to a potential hazard or unsafe practice that could result in injury or death.
 <b>CAUTION</b>	This symbol refers to a potential hazard or unsafe practice that could result in injury, product damage, or property damage.
<b>NOTICE</b>	This symbol refers to information that needs special attention or must be fully understood, even though not dangerous.

## IMPORTANT NOTES FOR INSTALLATION AND OPERATION

### **WARNING**

This is the safety alert symbol. It is used to alert you to potential personal injury hazards. Obey all safety messages that follow this symbol to avoid possible injury or death.

### **WARNING**

Do not attempt to operate this unit in the event of power failure.  
Adequate clearances must be maintained for safe and proper operation.

### **WARNING**

Disconnect the power supply to the appliance before cleaning or servicing.

### **IMPORTANT**

Improper installation, operation, adjustment, alteration, service or maintenance can cause property damage, injury or death. Read the installation, operating and maintenance instructions thoroughly before installing, operating or servicing this equipment.

### **NOTICE**

Contact the factory, the factory representative or local service company to perform maintenance and repairs.

### **NOTICE**

This product is intended for commercial use only. NOT FOR HOUSEHOLD USE.

### **NOTICE**

This manual should be retained for future reference.

It is recommended that this manual be read thoroughly and that all instructions be followed carefully.

Copyright © 2021 by Crown. All rights reserved. Published in the United States of America.

RETAIN THIS MANUAL FOR FUTURE REFERENCE.

## Table of Contents

Important Notes For Installation and Operation .....	2
Service Connections .....	4
Installation .....	9
Operation .....	13
Cooking Guidelines .....	16
Cleaning .....	17
Maintenance .....	18
Troubleshooting .....	19

# SERVICE CONNECTIONS

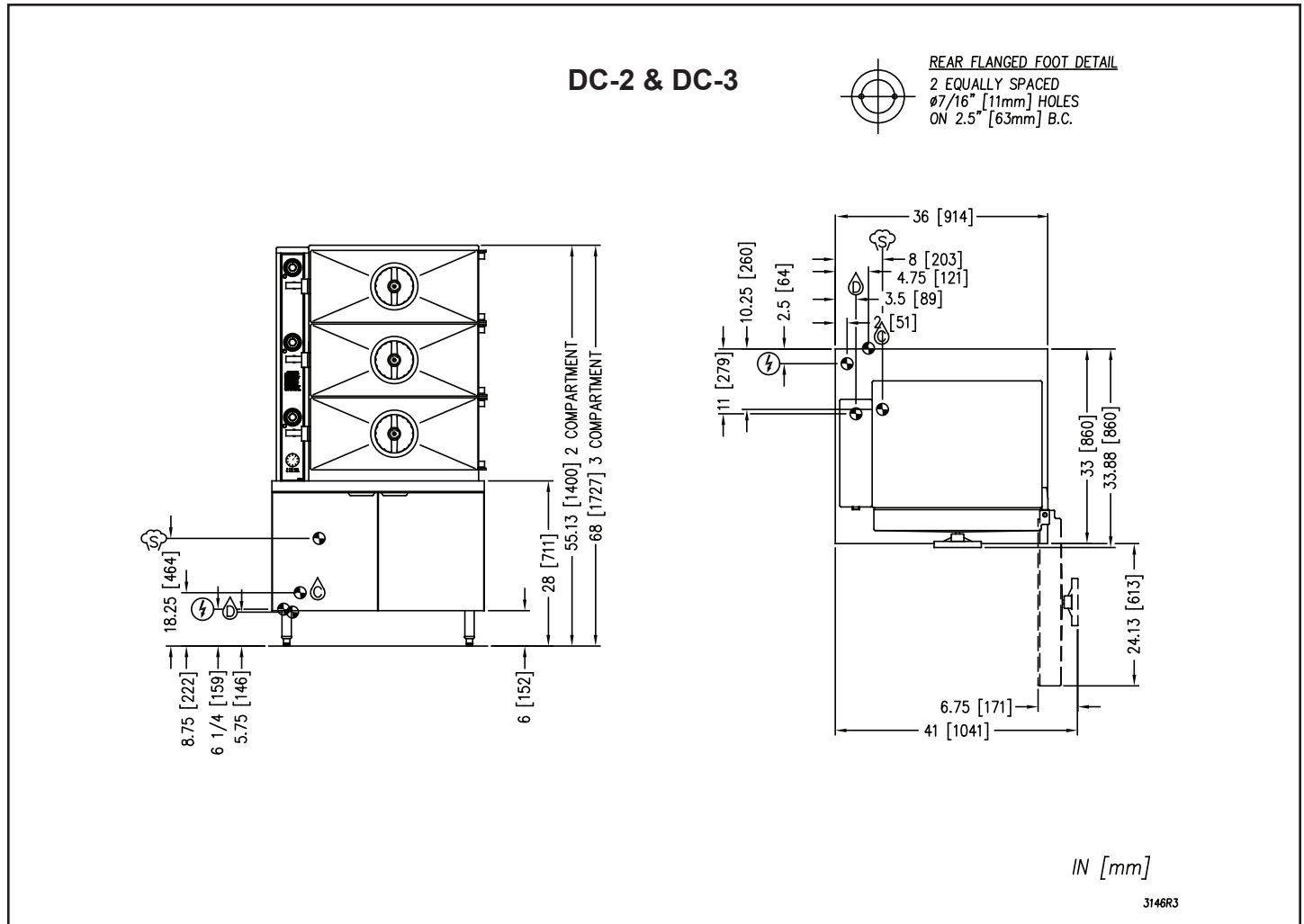

### SERVICE CONNECTIONS

- DRAIN: 2" (51 mm) IPS piped to open floor drain. No solid connection.
- COLD WATER: 3/8" O.D. tubing at 25-50 PSI (170-345 kPa).
- ELECTRICAL CONNECTIONS: 1/2" (13 mm) conduit connection to controls. 2 Amps per compartment, 120-60-1, 220-50-1.
- STEAM SUPPLY: 3/4" (19 mm) female pipe connection for steam supply 15-50 PSI (103-345 kPa)\*

\* Pressure reducing valve is required if incoming pressure exceeds 50 PSI (345 kPa)

### COMPARTMENT PAN CAPACITY

MODEL	COMPARTMENTS	CAPACITY
DC-2	2	8-16 Pans
DC-3	3	12-24 Pans

As continued product improvement is a policy of Crown, specifications are subject to change without notice.

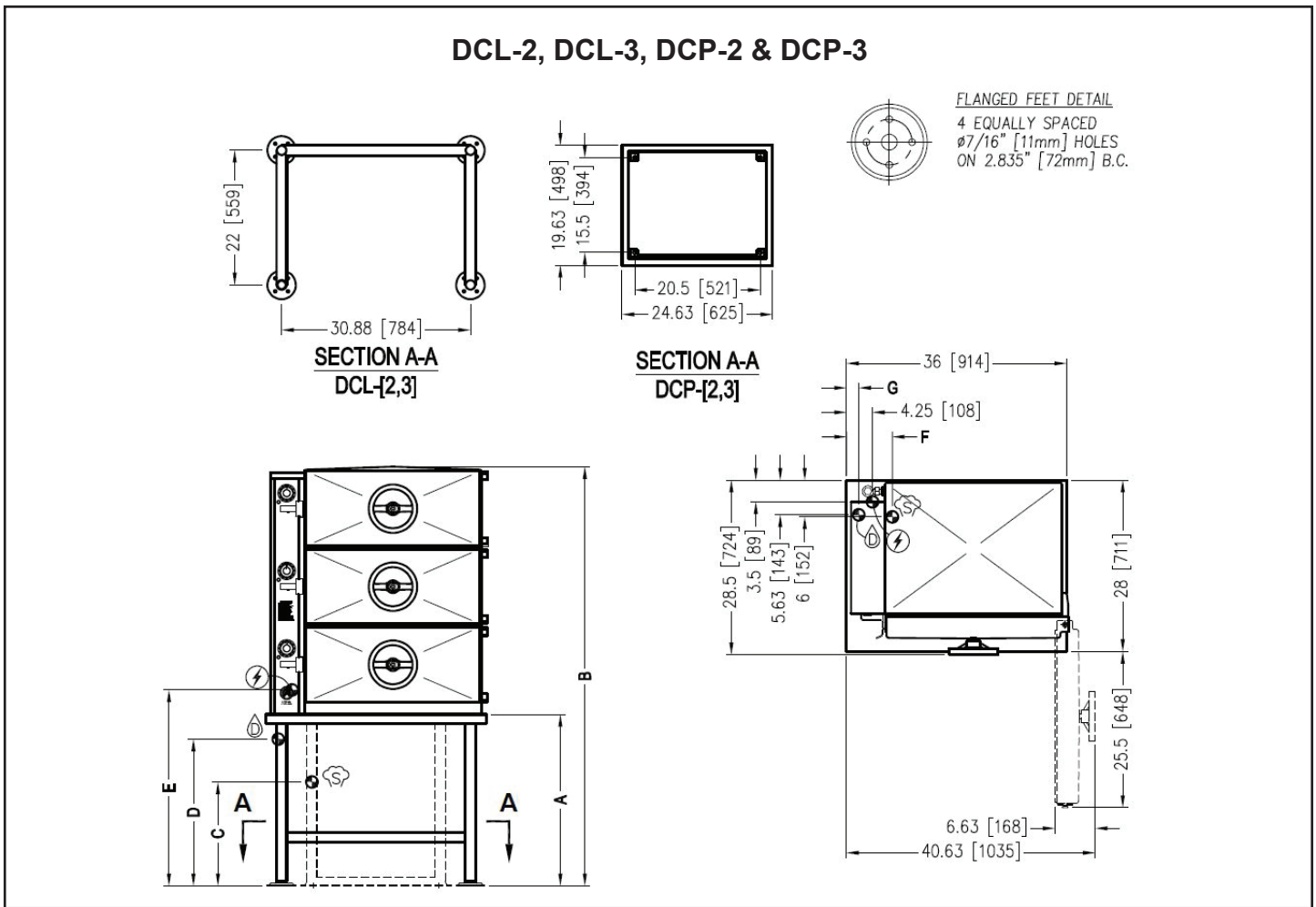

### SERVICE CONNECTIONS

⚡ – ELECTRICAL CONNECTION: 1/2" conduit connection to controls. 2 AMPS per compartment, 120-60-1 or 220-50-1

Ⓛ – DRAIN: 2" copper pipe to open floor drain. No solid connection.

Ⓢ – STEAM SUPPLY: 3/4" for incoming steam at 15-45 PSI (103-310 kPa)\*

*\* Pressure reducing valve is required if incoming pressure exceeds 50 PSI (345 kPa)*

### DIMENSIONS

MODEL	UNITS	A	B	C	D	E	F	G
DCL-2	in (mm)	28" (711)	55.75" (1416)	17" (432)	24" (610)	32" (813)	7.5" (191)	2" (51)
DCL-3		18" (457)	58.5" (1486)	7" (178)	14" (356)	22" (559)	7.5" (191)	2" (51)
DCP-2		28" (711)	55.75" (1416)	17" (432)	24" (610)	32" (813)	12.75" (324)	9" (229)
DCP-3		18" (457)	58.5" (1486)	7" (178)	14" (356)	22" (559)	12.75" (324)	9" (229)

### COMPARTMENT PAN CAPACITY

MODEL	COMPARTMENTS	CAPACITY
DC (P, L or W) -2	2	8-16 Pans
DC (P, L or W) -3	3	12-24 Pans

As continued product improvement is a policy of Crown, specifications are subject to change without notice.

DCP-2 , DCP-3 & DCP-4

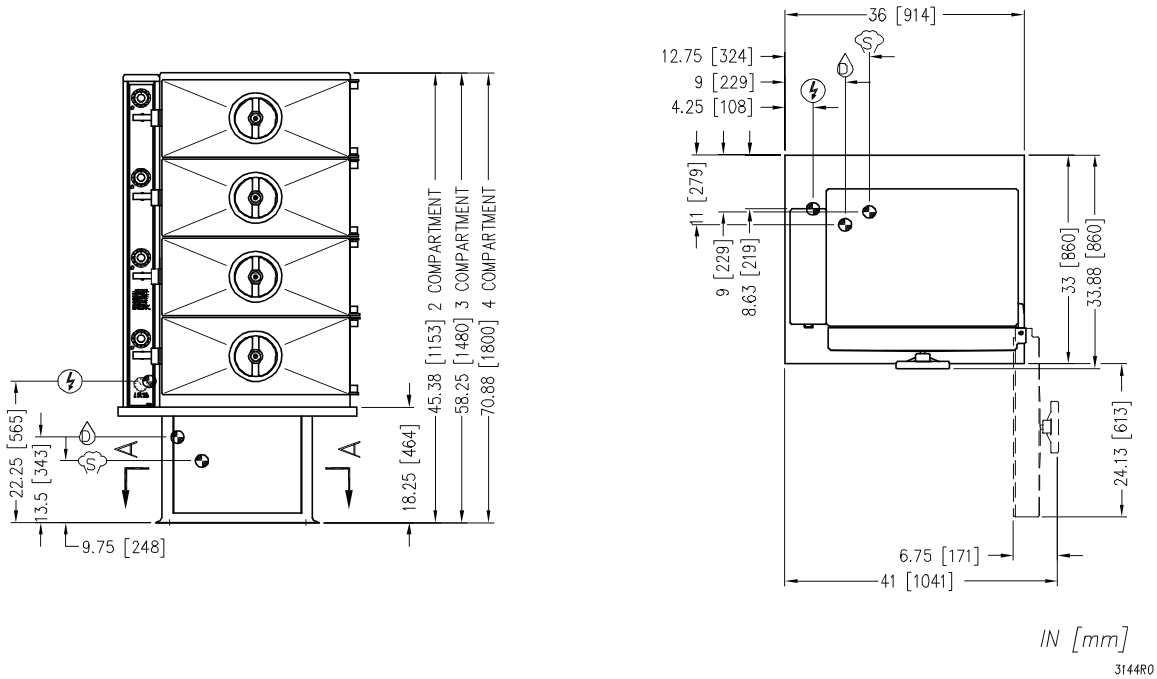
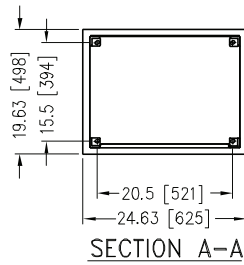



SERVICE CONNECTIONS

- ⚡ – ELECTRICAL CONNECTION: 1/2" (13 mm) conduit connection to controls. 2 AMPS per compartment, 120-60-1 or 220-50-1
- 💧 – DRAIN: 2" (51 mm) IPS piped to open floor drain. No solid connection.
- ⚙️ – STEAM SUPPLY: 3/4" for incoming steam at 40-50 PSI (276-345 kPa)\*

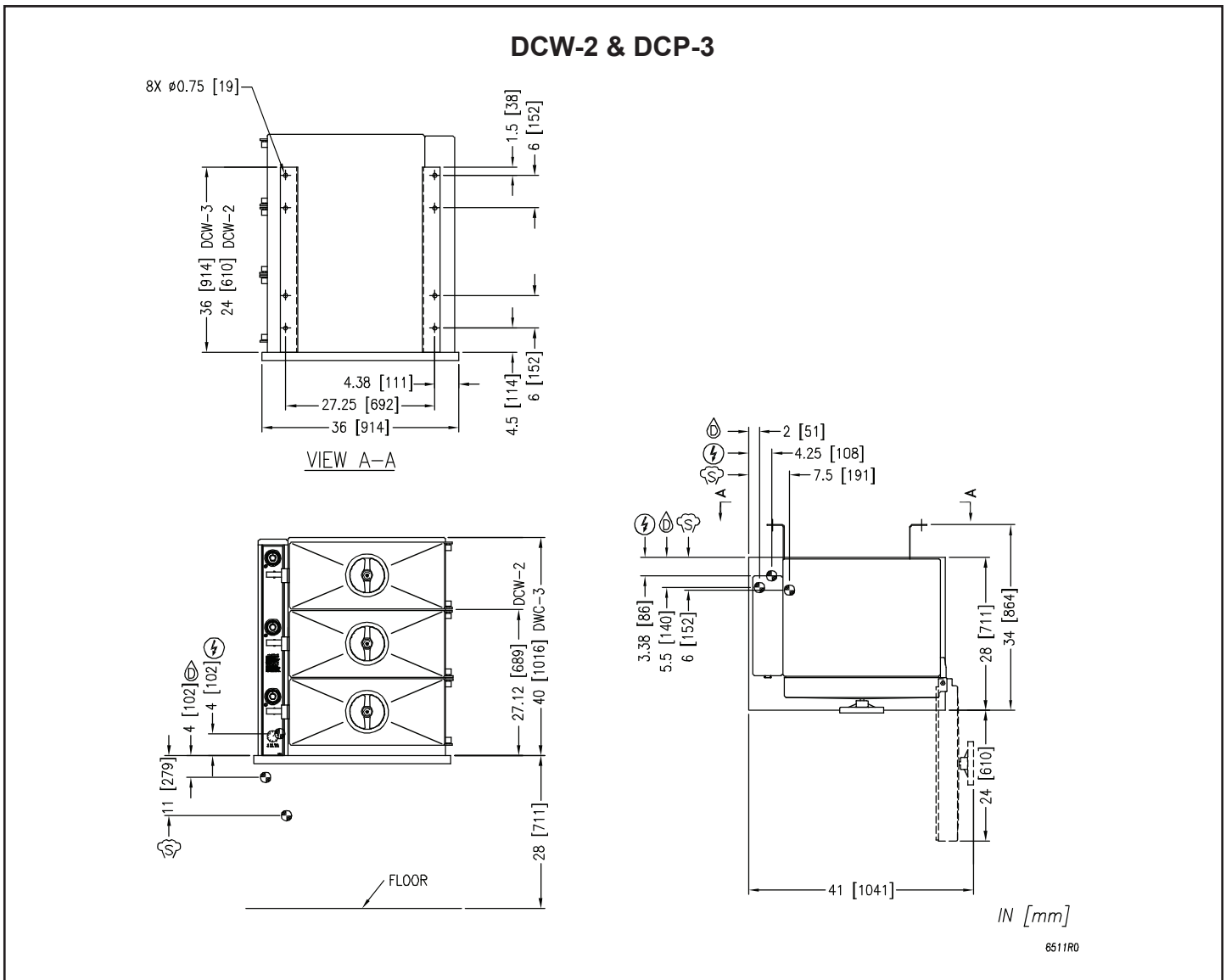
\* Pressure reducing valve is required if incoming pressure exceeds 50 PSI (345 kPa)



**SERVICE CONNECTIONS**

-  – ELECTRICAL CONNECTION: 1/2" (13 mm) conduit connection to controls. 2 AMPS per compartment, 120-60-1 or 220-50-1
-  – DRAIN: 2" (51 mm) IPS piped to open floor drain. No solid connection.
-  – STEAM SUPPLY: 3/4" (19 mm) IPS for incoming steam at 5-50 PSI (35-345 kPa)\*

\* Pressure reducing valve is required if incoming pressure exceeds 50 PSI (345 kPa)

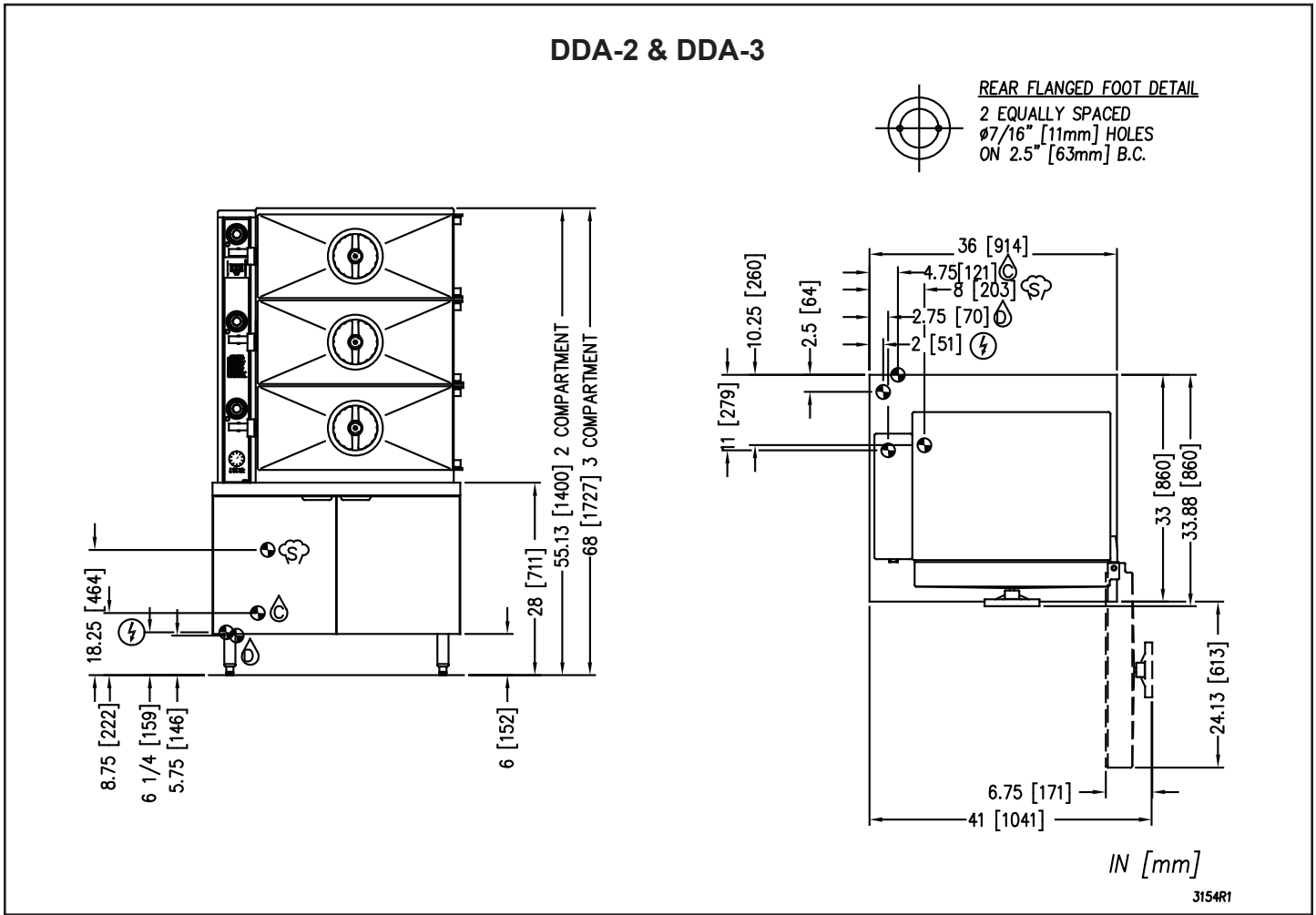

### SERVICE CONNECTIONS

- ⚡ – ELECTRICAL CONNECTIONS: 1/2" (13 mm) conduit connection to controls. 2 Amps per compartment, 120-60-1, 220-50-1.
- 💧 – COLD WATER: 3/8" O.D. tubing at 25-50 PSI (170-345 kPa).
- Ⓛ – DRAIN: 2" (51 mm) IPS piped to open floor drain. No solid connection.
- ⊞ – STEAM SUPPLY: 3/4" (19 mm) IPS for incoming steam at 15-50 PSI (103-345 kPa).\*

\* Pressure reducing valve is required if incoming pressure exceeds 50 PSI (345 kPa)

### COMPARTMENT PAN CAPACITY

MODEL	COMPARTMENTS	CAPACITY
DDA-2	2	8-16 Pans
DDA-3	3	12-24 Pans

# INSTALLATION

## GENERAL

Models DC-2, DC-3, DCL-2, DCL-3, DCP-2, DCP-3, DCW-2, DCW-3, DDA-2, DDA-3 cookers have two or three pressurized steaming compartments for cooking vegetables, fish, eggs and other foods. Models DC are mounted on a cabinet base, models DCL on a leg base, models DCP on a pedestal base and models DCW are wall mounted.

Models DDA-2 and DDA-3 cookers also have two or three compartments; the upper compartment can be switched to provide either pressurized or pressureless steam while the lower compartment(s) provide pressurized cooking only.

Accessory 12 × 20" stainless steel pans are available, solid or perforated, in 2.5", 4" and 6" depth.

## ACCOMMODATION

MODEL	COMPARTMENTS	TOTAL NUMBER OF PANS			NUMBER OF PANS PER COMPARTMENT		
		2.5" DEPTH	4" DEPTH	6" DEPTH	2.5" DEPTH	4" DEPTH	6" DEPTH
DC-2, DCL-2, DCP-2, DCW-2, DDA-2	2	16	8	4	8	4	2
DC-3, DCL-3, DCP-3, DCW-3, DDA-3	3	24	12	6			
DCL-4, DCP-4	4	32	16	8			

Each compartment has a 0 to 60 minute timer and a buzzer that requires manual shut-off. Doors cannot be opened during cooking. Each door is equipped with an interlock feature that stops delivery of steam to the compartment before the door can be opened.

## UNPACKING

### IMMEDIATELY INSPECT FOR SHIPPING DAMAGE

Immediately after unpacking, check for possible shipping damage. If the appliance is found to be damaged, save the packaging material and contact the carrier within 15 days of delivery.

We cannot assume responsibility for damage or loss incurred in transit.

Before installing, verify the electrical rating agrees with the specification on the rating plate.

## LOCATION

Position the appliance in its installation location. Check that there are sufficient clearances to service the controls, door swing, etc. Also adequate clearance must be left for making the required supply and drain connections.

Allow enough space between any other piece of equipment or wall for service access.

Service to the controls may be required on the left and/or right side panels of the cabinet.

## INSTALLATION CODES AND STANDARDS

The appliance must be installed in accordance with:

### In Canada:

Provincial and local codes, or in the absence of local codes, with the Canadian Electric Code, CSA C22.1 (latest edition). Copies may be obtained from the Canadian Standards Association, 178 Rexdale Blvd., Etobicoke, Ontario, Canada, M9W 1R3.

### In the USA:

State and local codes, or in the absence of local codes, with the National Electrical Code, ANSI/NFPA-70 (latest edition). Copies may be obtained from The National Fire Protection Association, Batterymarch Park, Quincy, MA, 02269.

## LEVELING AND ANCHORING THE APPLIANCE

### DC, DCL and DDA MODELS

1. Place appliance in the installation position.
2. Using a spirit level or pan of water, level the appliance. Then elevate the right side about 1/8" to assure proper compartment drainage.
3. Mark hole locations on the floor through the anchoring holes provided in the rear flanged adjustable feet.
4. Remove appliance from installation position and drill holes in locations marked on the floor. (See Installation Diagram on page 4.) Insert proper anchoring devices (not supplied).
5. Place appliance back in the installation position.
6. Recheck level.
7. Bolt and anchor appliance securely to the floor.
8. Seal bolts and flanged feet with silastic or equivalent compound.

### DCP MODELS

1. Place appliance in the installation position.
2. Using spirit level or pan of water, level the appliance. Then elevate the right side about 1/8" to assure proper compartment drainage.
3. Mark hole locations on the floor through the anchoring holes provided in the pedestal base.
4. Remove appliance from installation position and drill holes in locations marked on the floor. Insert proper anchoring devices (not provided).
5. Place appliance back in the installation position.
6. Recheck level. Use shims if required to level.
7. Bolt and anchor appliance to floor.
8. Seal bolts and edge of pedestal with silastic or equivalent compound.

### DCW MODELS

1. Unit supplied with mounting brackets suitable for wall mounting.
2. Wall must be suitable to safely carry appliance fully loaded with product.
3. Appliance must be mounted so that it is level side to side and front to back.
4. Hardware (anchoring devices and bolts not provided) must be suitable to carry load safely.

## ELECTRICAL CONNECTIONS

 **WARNING**

Electrical and grounding connections must comply with the applicable portions of the National Electrical Code and/or other local electrical codes.

 **WARNING**

Disconnect electrical power supply and place a tag at the disconnect switch to indicate you are working on the circuit.

When making electrical connections, use copper wire suitable for at least 200 °F (90 °C). The steamer must be grounded in accordance with the National Electrical Code or applicable local codes. The wiring diagram is located on the inside of the right panel.

## EXHAUST HOOD

An exhaust system should be located directly above the steamer to exhaust steam and heat generated by the steamer.

## PLUMBING CONNECTIONS

 **WARNING**

Plumbing connections must comply with applicable sanitary, safety, and plumbing codes.

## WATER SUPPLY CONNECTION - WHERE APPLICABLE

The incoming cold water supply connection, at the rear of the cabinet, requires 3/8" tubing and water pressure of 25 to 50 psi. A manual shut-off valve must be provided convenient to the appliance; this valve should be open when the appliance is in operation.

## DRAIN CONNECTION

The appliance drain (2" IPS) should be piped to a floor drain near the appliance. There should be no solid drain connection; an "open gap" between the appliance and the floor drain is required.

## INFORMATION TO STEAM FITTER

Each cooking compartment requires approximately 1 BHP (34.5 lbs. of steam per hour to operate satisfactorily. Therefore a two compartment requires 2 BHP and a three compartment requires 3 BHP.

Assuming availability of a 30 psi supply steam pressure immediately to the appliance, then pipe sizes of 1/2", 3/4" or 1" will deliver respectively 90, 165 or 385 lbs. of steam per hour to the appliance Heat Exchanger. From the foregoing, a 1/2" pipe line is not recommended.

An important consideration is the pressure drop that will occur through the steam supply line from its point of origin to the appliance. The greater the length of piping and number of valves and elbows, the greater will be the pressure losses.

Consider a pressure drop of 1 (one) psi for each straight length of pipe equivalent to 120 diameters of that pipe. Thus, a 1" pipe having a straight length of 120" (10 feet) is equivalent to 120 diameters of that pipe and will have a pressure loss of 1 psi through that pipe.

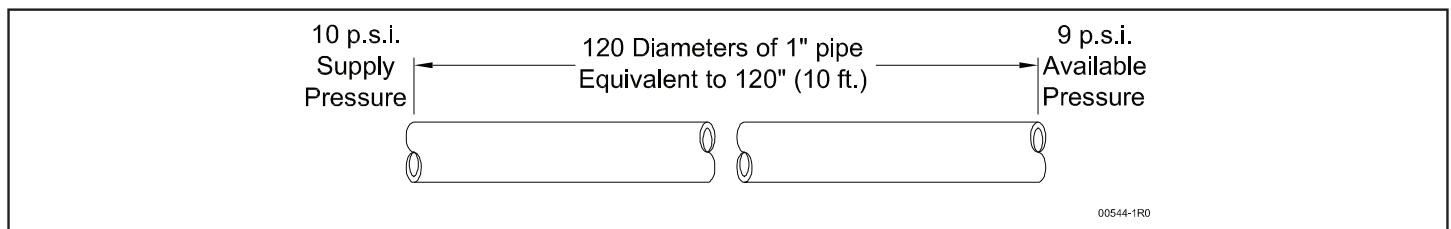

**NOTE:** In 3/4" pipe size, that a Standard 90° Elbow and Angle Valve and a Globe Valve are equivalent to 1.8 feet, 10 feet and 18 feet respectively of straight pipe.

Similarly, in a 1" pipe size, a standard 90° Elbow and Angle Valve and a Globe Valve are equivalent to 2.2 feet, 12 feet and 23 feet respectively of straight pipe.

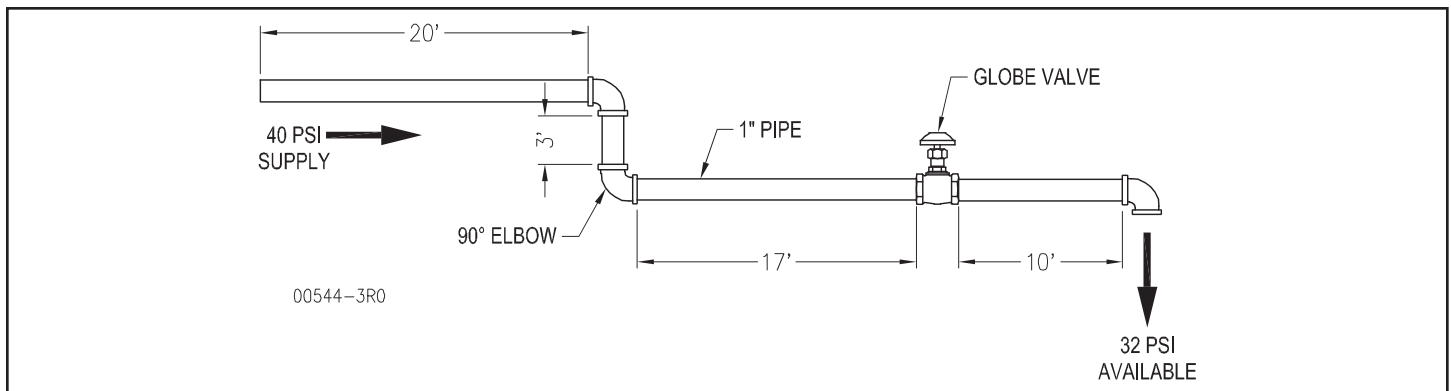

### Example:

Total of above = 20 + 2.2 + 3 + 2.2 + 17 + 23 + 10 + 2.2 = 79.6 feet. Since each 10 feet is equivalent to 1 psi pressure loss, 79.6 feet is equivalent to approximately 32 psi from an original boiler supply of 40 psi.

It is suggested that, wherever possible, the steam supply line to the appliance is a separate line from the steam source. If the appliance must be supplied from a line supplying other appliances, the pipe sizes and pressure will have to be verified. Further, during idle periods, when the steam in the supply line is not in use, water will form from condensed steam in the supply line. It is advisable to prevent water pockets from forming in the steam line and impeding the steam flow when it is required. Therefore, the steam supply line should be installed level or run slightly downwards towards the appliance. Install a Ball Float Trap near the appliance to drain out water (condensed steam) from the line to assure clean dry steam to the appliance.

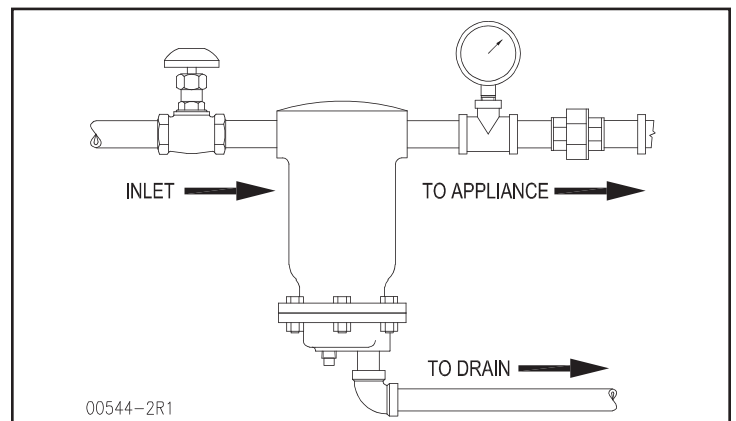

# OPERATION

 **CAUTION**

Operating, testing, and servicing should only be performed by qualified personnel.

 **CAUTION**

The appliance and its parts are hot. Use care when operating, cleaning and servicing the appliance.

## INITIAL OPERATIONS CHECK

The pressure gauge on the face of the Cooker Control Panel should indicate pressure of 5 to 6 psi. Open cooker compartment door, set timer dial to 5 minutes, pull out operating handle and observe that steam is entering the compartment.

 **CAUTION**

Stand clear of compartment opening as live steam is being released.

Set timer dial back to "0". The buzzer will sound and may only be silenced by pushing in on the operating handle. Check each compartment in this manner.

Close compartment door and turn handwheel clockwise so the door gasket seals.

Set timer at 5 minutes. Pull out operating handle and set in position. Steam should be heard entering the compartment; also you should hear a hissing sound as compartment air exits the vent at the rear side, until replaced by steam.

Observe that door gasket seals properly and that no leaks are evident.

After five minutes: Timer should read "0", steam will stop entering compartment, the exhaust valve will open allowing steam and condensate water to exit, and the buzzer will sound.

To silence the buzzer, push in the operating handle.

## DO-ALL MODELS ONLY

Observe that water is flowing at the open drain. Steam from the compartment is cooled by a flow of cold water from the thermostatically controlled valve. Pause one minute to allow steam and condensate to exit. Turn handwheel counterclockwise to avoid pressure on the door gasket when not in use.

Move the door latch to the left to release and open the door. Check each compartment in this manner.

 **CAUTION**

The steamer and its parts are hot. Use care when operating, cleaning, or servicing the steamer.

 **CAUTION**

Live steam and accumulated hot water in the compartment may be released when the door is opened.

## COMPARTMENT CONTROLS

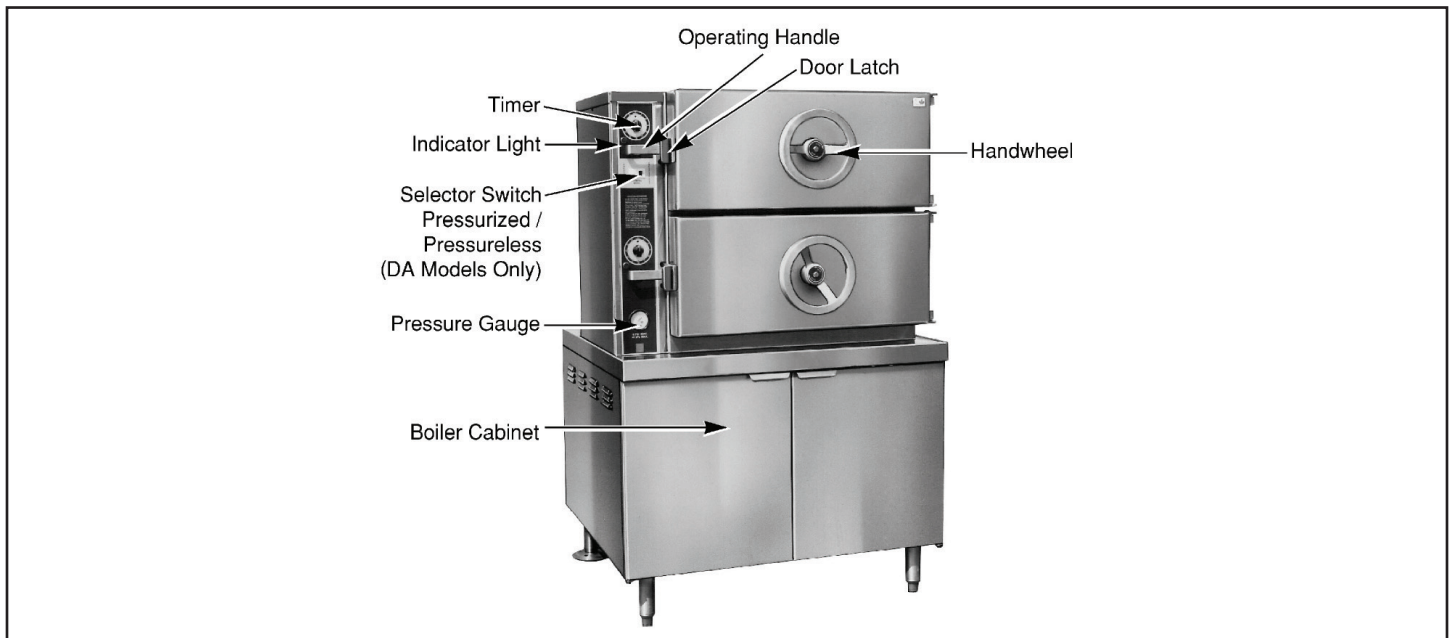

- Timer (0 to 60 minutes)** - Sets the steam time for the compartment.
- Indicator Light** - Timed cycle is in progress when lit.
- Selector Switch** - PRESSURIZED means top compartment operates at 6 psi.  
PRESSURELESS means top compartment steams without pressure, the exhaust valve is open to the drain.
- Operating Handle** - PULL OUT to send steam to compartment, lock door, and enable operation. PUSH IN to silence buzzer at end of cycle.
- Door Latch** - Holds door closed and prevents door from fully opening until operating handle is pushed in; move the door latch to the left to fully open door after steam and condensate drain (1 minute) and handwheel is turned fully counterclockwise.
- Handwheel** - Turn clockwise to seal door at start of cycle. After pressure release at end of cycle, turn counterclockwise to open.
- Buzzer (not shown)** - Sounds an audible signal when timer cycle is complete. To silence buzzer, push in operating handle.
- Pressure Gauge** - Indicates steam pressure: 6 psi with compartments inactive, 4.5 - 6 psi during a cooking cycle.

## STEAMING

Each steaming compartment is controlled by its own controls. When a compartment is not operating, the drain is open and the steam inlet valve from the boiler is closed. Food, properly portioned and in appropriate solid or perforated pans, is placed on rack supports (or wire shelves) in the steaming compartment. After closing and sealing the door, setting the timer, and pulling out the operating handle, the steam inlet valve from the boiler opens, allowing steam at a pressure of 6 psi to enter the compartment. Air from the sealed compartment exits through the vent until the temperature reaches 180 °F; then the vent closes and the compartment can become pressurized. [On DDA models only, if the top compartment has been switched to pressureless steaming, steam enters the compartment and is exhausted to the drain without pressurizing the compartment.] Steaming continues until the timer reaches "0" and the buzzer sounds. To silence the buzzer, push in the operating handle. Wait one minute for steam or hot water to drain away. Open the door and remove the cooked food.

The cabinet (lower portion of steamer) contains the pressure regulator. On DDA models there is also the drain assembly, water cooling valve, power switch, pilot light and drain thermostat.

## PREHEAT COMPARTMENTS

If the cooker has been standing idle and the compartments are cold, preheat before loading.

## GENERAL

Turn on power and steam supply to appliance. DDA Models open left door of cabinet and turn on Power Switch. Pilot light will come ON indicating power to the condensate valve and drain thermostat.

## SHUT DOWN

Turn off power switch and steam supply to appliance.

# COOKING GUIDELINES

The cooking guidelines in this manual are suggestions only. You should experiment with your food products to determine cooking times that will give you the best results. Variables which affect cooking time include size, weight, thickness of foods, temperature, density, previous condition of the foods (fresh, pre-blanching or frozen) and degree of doneness desired.

To allow steam to circulate around the pans, food must be spread evenly throughout the pans. Best results are obtained after the compartments are allowed to preheat. When all compartments are to be loaded at the same time, it is best to allow the first compartment to reach 4 - 4.5 psig before starting the next compartment. When processing frozen vegetables, use half the suggested pan weights and allow sufficient time for cooking doneness.

PRODUCT	PAN DEPTH	PERFORATED OR SOLID	WEIGHT/QUANTITY PER PAN	STEAM TIME MINUTES	PANS PER COMPARTMENT
VEGETABLES (Fresh)					
Beans, lima	2.5"	Perforated	5 lbs.	10 - 12 13 - 15	1 - 3 4 - 6
Beans, string or wax	2.5"	Perforated	6 lbs.	15 - 20 20 - 25	1 - 3 4 - 6
Broccoli, florets	2.5"	Perforated	6 lbs.	8 - 10 10 - 12	1 - 3 4 - 6
Broccoli, stalks	2.5"	Perforated	6 lbs.	10 - 15 15 - 20	1 - 3 4 - 6
Carrots, sliced	2.5"	Perforated	9 lbs.	18 - 21 21 - 25	1 - 3 4 - 6
Corn	2.5"	Perforated	5 lbs.	9 - 10 11 - 13	1 - 3 4 - 6
Peas	2.5"	Perforated	5 lbs.	6 - 7 8 - 9	1 - 3 4 - 6
Potatoes, chunked	2.5"	Perforated	10 lbs.	20 - 25 25 - 30	1 - 3 4 - 6
Spinach, cut, cleaned	4"	Perforated	3 lbs.	3 - 5 4 - 6	1 - 2 3 - 4
Vegetables, canned	2.5"	Solid	7 lbs.	4 - 5 5 - 8	1 - 3 4 - 6
OTHER FOODS					
Chicken	2.5"	Perforated	8 lbs.	18 - 25 25 - 30	1 - 3 4 - 6
Eggs, out-of-shell	2.5"	Solid	4 doz.	6 - 7 7 - 8	1 - 3 4 - 6
Eggs, in-shell	2.5"	Perforated	3 doz.	2 - 3 4 - 6	1 - 3 4 - 6
Fish, fillets	2.5"	Perforated	3 lbs.	8 - 12 10 - 15	1 - 3 4 - 6
Meatloaf	2.5"	Solid (for broth)	15 lbs.	35 - 40 40 - 45	1 - 3 4 - 6
Rice, add 1 gallon water	4"	Solid	4 lbs.	22 - 24 25 - 27	1 - 2 3 - 4
Spaghetti, add 7 quarts of water	4"	Solid	3 lbs.	20 - 22 23 - 26	1 - 2 3 - 4
Turkey	2.5"	Perforated	10 - 12 lbs.	50 - 60 60 - 75	1 - 3 4 - 6

# CLEANING

 **WARNING**

Disconnect the power supply to the appliance before cleaning or servicing.

 **WARNING**

Never spray water into electric controls.

 **CAUTION**

The appliance and its parts are hot. Use care when operating, cleaning or servicing the appliance.

 **CAUTION**

Do not use cleaning agents that are corrosive.

Keep exposed cleanable areas of unit clean at all times. Use a mild soap and warm clean water. Rinse thoroughly with clean water and wipe dry with a clean soft cloth.

Remove pans, shelves, slide racks and compartment strainers and clean using mild warm clean soapy water.

Remove food sediment from compartment and thoroughly wash oven cavities, door liners and door gaskets at the end of each day or as required.

Never use steel wool on stainless steel.

Do not apply food oils or petroleum lubricants to the door gaskets.

Replace racks, shelves and compartment strainers.

Turn handwheel fully counterclockwise to retract the gasket plate and avoid pressure on the door gasket when the steamer is not in use.

# MAINTENANCE

Keep all exposed cleanable areas of unit clean at all times.

 **CAUTION**

An obstructed drain can cause personal injury or property damage.

Do not allow any sediment to be exhausted through exhaust valves (compartment drains). Remove all sediment and clean. Greasy foods may leave deposits that will accumulate in the exhaust drain and drain lines. To remove close doors and seal, set timers and at frequent intervals release operating arm and blowdown unit, releasing steam through valves and drain lines to dissolve grease.

The thrust screw in each compartment door should be lubricated each month to prevent handwheel from becoming difficult to turn. To lubricate, turn handwheel clockwise until gasket plate is fully extended. Grasp finger hooks on door plate and lift up and out. Apply grease NLG12 consistency of 285W60 viscosity liberally on thrust screw, rotate handwheel to ensure complete coverage. Replace gasket plate.

**NOTICE**

As a safety precaution, disconnect the power supply before cleaning or servicing.

# TROUBLESHOOTING

## COOKER

### DOOR HASP WILL NOT ENGAGE

1. Door loose and requires new bushings.
2. Hasp requires adjustment by adding or removing of washers under hasp.

### HANDWHEEL HARD TO TURN

1. Foreign matter on thrust screw or lack of lubricant.
2. Thrust screw bent or worn.

### DOOR GASKET LEAKS

1. Gasket screw loose.
2. Gasket damaged or at end of useful life.
3. Door loose and not aligned correctly.
4. Gasket plate installed incorrectly.
5. Handwheel binding so that not enough pressure to seal door.

### WATER ACCUMULATES IN COMPARTMENTS

1. Appliance not levelled properly.
2. Compartment screen plugged.
3. Exhaust valve plugged or defective.
4. Exhaust drain line plugged.

### COMPARTMENT PRESSURIZED AT END OF COOKING CYCLE

1. Exhaust valve plugged or defective.

### STEAM ESCAPES FROM COMPARTMENT DURING COOKING CYCLE

1. Compartment vent plugged.
2. Exhaust valve plugged or defective.

### COOKING CYCLE CANNOT BE ACTIVATED

1. Loose wire terminations.
2. Steam valve plugged or defective.
3. Timer defective.
4. Micro switch on operation arm defective or requires adjustment.

#### NOTICE

At least twice a year have an authorized service person clean and adjust the unit for maximum performance.

# DC-2, DC-3, DDA-2, DDA-3, DCL-2, DCL-3, DCP-2, DCP-3, DCW-2 & DCW-3

## Direct Steam Compartment Cookers



A product with the Crown name incorporates the best in durability and low maintenance. We all recognize, however, that replacement parts and occasional professional service may be necessary to extend the useful life of this appliance. When service is needed, contact a Crown Authorized Service Agency, or your dealer. To avoid confusion, always refer to the model number, serial number, and type of your appliance.



### CROWN FOOD SERVICE EQUIPMENT



A Middleby Company  
70 Oakdale Road, Downsview (Toronto) Ontario, Canada, M3N 1V9  
Telephone: 919-762-1000      [www.crownsteamgroup.com](http://www.crownsteamgroup.com)