



IMPORTANT FOR FUTURE REFERENCE Please complete this information and retain this manual for the life of the equipment:
Model #: _____
Serial #: _____
Date Purchased: _____

Installation & Operation Manual

Direct Steam Convection Steamer DCX-16 & DCX-24



Model DCX-16

WARNING

Improper installation, adjustment, alteration, service or maintenance can cause property damage, injury or death. Read the installation, operating and maintenance instructions thoroughly before installing or servicing this equipment.

CROWN FOOD SERVICE EQUIPMENT

 A Middleby Company

70 Oakdale Road, Downsview (Toronto) Ontario, Canada, M3N 1V9



Telephone: 919-762-1000

www.crownsteamgroup.com

SAFETY PRECAUTIONS

Before installing and operating this equipment, be sure everyone involved in its operation is fully trained and aware of precautions. Accidents and problems can be caused by failure to follow fundamental rules and precautions.

The following symbols, found throughout this manual, alert you to potentially dangerous conditions to the operator, service personnel, or to the equipment.

 DANGER	This symbol warns of immediate hazards that will result in severe injury or death.
 WARNING	This symbol refers to a potential hazard or unsafe practice that could result in injury or death.
 CAUTION	This symbol refers to a potential hazard or unsafe practice that could result in injury, product damage, or property damage.
NOTICE	This symbol refers to information that needs special attention or must be fully understood, even though not dangerous.

IMPORTANT NOTES FOR INSTALLATION AND OPERATION

WARNING

This is the safety alert symbol. It is used to alert you to potential personal injury hazards. Obey all safety messages that follow this symbol to avoid possible injury or death.

WARNING

Improper installation, operation, adjustment, alteration, service or maintenance can cause property damage, injury or death. Read the installation, operating and maintenance instructions thoroughly before installing, operating or servicing this equipment.

CAUTION

Operating, testing, and servicing should only be performed by qualified personnel.

NOTICE

Contact the factory, the factory representative or local service company to perform maintenance and repairs.

NOTICE

This product is intended for commercial use only. NOT FOR HOUSEHOLD USE.

NOTICE

This manual should be retained for future reference.

It is recommended that this manual be read thoroughly and that all instructions be followed carefully.

RETAIN THIS MANUAL FOR FUTURE REFERENCE.

Table of Contents

Important Notes For Installation and Operation	2
Service Connections	4
Introduction	6
Installation Instructions	7
Operation	10
Cleaning.....	11
Troubleshooting	12
Cooking Chart.....	13

SERVICE CONNECTIONS



FLANGED FOOT DETAIL
 2 EQUALLY SPACED
 Ø7/16" [11mm] HOLES
 ON 2.5" [63mm] B.C.

DCX-16

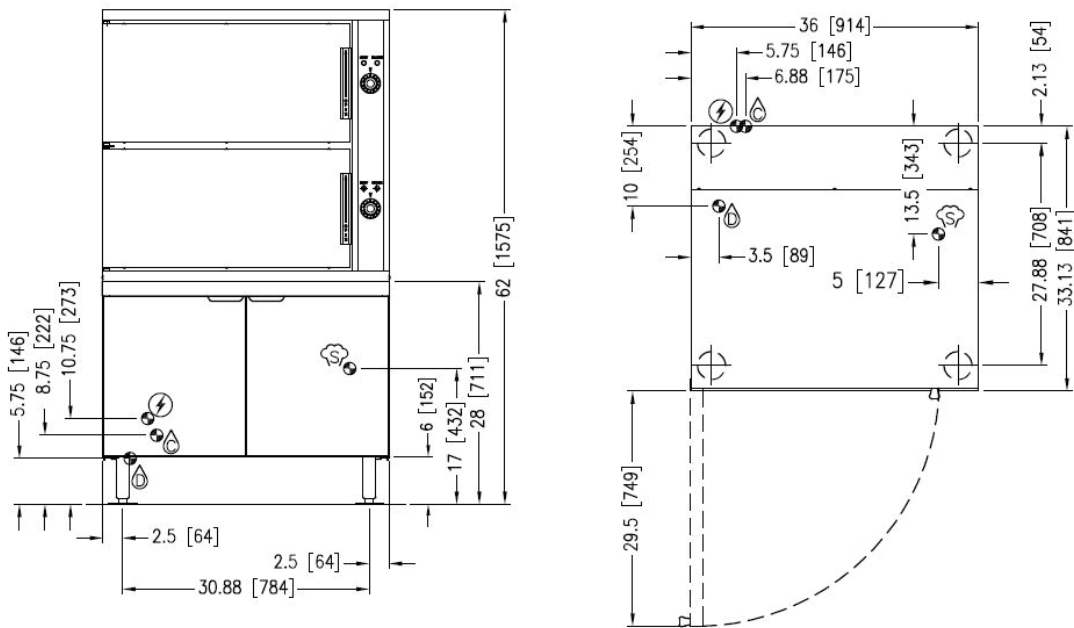

IN [mm]

2795R4

SERVICE CONNECTIONS

- CONDENSATE COLD WATER: 1/2 NPT, 25-50 PSI (170-345 kPa) (OPTIONAL)
- DRAIN: 2" (51 mm) IPS piped to open floor drain. No solid connection.
- ELECTRICAL CONNECTION: 1/2" (13 mm) conduit connection to controls. 2 Amps per compartment, 115-60-1.
- STEAM SUPPLY: 3/4" IPS at minimum 15 PSI (103KPa)

**Pressure reducing valve is required if incoming pressure exceeds 45 PSI (310 kPa)*

MISCELLANEOUS

MODEL	PAN DEPTH				
	1"	2-1/2"	4"	4" & 1"	4" & 2-1/2"
DCX-16	16	8	4	2 x 4" 2 x 1"	2 x 4" 1 x 2-1/2"

MODEL	SHIPPING WEIGHT	MINIMUM CLEARANCE	
DCX-16	750 lbs [340 kg]	SIDES	0
		BACK	0



FLANGED FOOT DETAIL
 2 EQUALLY SPACED
 $\varnothing 7/16"$ [11mm] HOLES
 ON 2.5" [63mm] B.C.

DCX-24

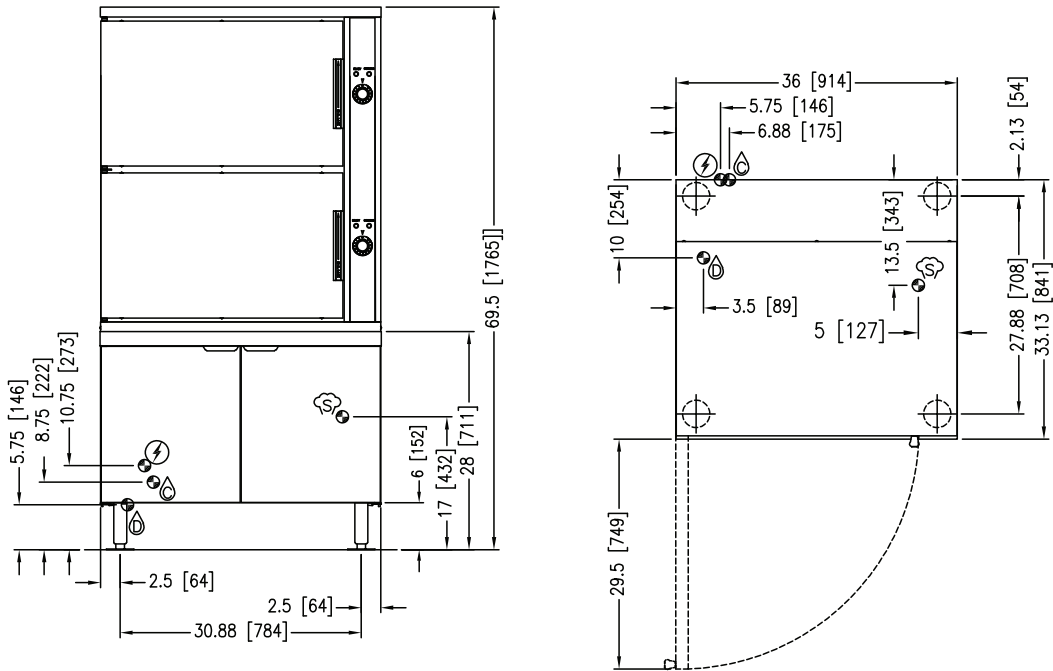

IN [mm]

8815R0

SERVICE CONNECTIONS

- CONDENSATE COLD WATER: 1/2 NPT, 25-50 PSI (170-345 kPa) (OPTIONAL)
- DRAIN: 2" (51 mm) IPS piped to open floor drain. No solid connection.
- ELECTRICAL CONNECTION: 1/2" (13 mm) conduit connection to controls. 2 Amps per compartment, 120-60-1.
- STEAM SUPPLY: 3/4" IPS at minium 15 PSI (103KPA)

**Pressure reducing valve is required if incoming pressure exceeds 45 PSI (310 kPa)*

MISCELLANEOUS

MODEL	PAN DEPTH				
	1"	2-1/2"	4"	4" & 1"	4" & 2-1/2"
DCX-24	24	12	8	4 x 4" 12 x 1"	4 x 4" 2 x 2-1/2"

MODEL	SHIPPING WEIGHT	MINIMUM CLEARANCE	
DCX-24	800 lbs [363 kg]	SIDES	0
		BACK	0

INTRODUCTION

DESCRIPTION

Models DCX-16 and DCX-24, convection steamers mounted on 36" cabinet base. This steamer requires external source of CLEAN STEAM. See *SERVICE CONNECTIONS* Section for minimum pressure and volume requirements. DCX-16 steamer has a pan capacity of 16 (2 ½") pans. DCX-24 steamer has a pan capacity of 24 (2 ½") pans.

BASIC FUNCTION

Gas Fired Steamers

The sequence of operation is as follows:

Turn on the main power switch. A green pilot light will indicate main power is on and steam generating will begin.

With the READY pilot light on, preheat steamer compartment for one minute when the steamer is to be first used for the day or whenever the compartment is cold.

If appliance is equipped with optional - "Load Compensating Timer" a pre-heat thermostat is installed in each compartment. This allows the compartment to pre-heat to 185EF before the cooking time starts. Set timer for one minute. Ready light will go out and cook light will come on; steam will enter compartment. Once compartment has reached the pre-heat temperature (185EF) the timer will start. After the time selected has elapsed, buzzer will sound indicating the end of the cooking cycle. Steam generation will cease, Cook light will go out and Ready light will come on. To silence buzzer turn timer to its off position.

 **CAUTION**

Live steam and accumulated hot water in the compartment may be released when the door is opened.

INSTALLATION INSTRUCTIONS

UNPACKING

IMMEDIATELY INSPECT FOR SHIPPING DAMAGE

Immediately after unpacking, check for possible shipping damage. If the appliance is found to be damaged, save the packaging material and contact the carrier within 15 days of delivery.

We cannot assume responsibility for damage or loss incurred in transit.

Before installing, verify the electrical rating agrees with the specification on the rating plate.

LOCATION

Position the appliance in its installation location. Check that there are sufficient clearances to service the controls, door swing, etc. Also adequate clearance must be left for making the required supply and drain connections.

Allow enough space between any other piece of equipment or wall for service access. Service to the controls may be required on the left and/or right side panels of the cabinet.

INSTALLATION CODES AND STANDARDS

The appliance must be installed in accordance with:

In Canada:

Provincial and local codes, or in the absence of local codes, with the Canadian Electric Code, CSA C22.1 (latest edition). Copies may be obtained from the Canadian Standards Association, 178 Rexdale Blvd., Etobicoke, Ontario, Canada, M9W 1R3.

In the U.S.A.:

State and local codes, or in the absence of local codes, with the National Electrical Code, ANSI/NFPA-70 (latest edition). Copies may be obtained from The National Fire Protection Association, Batterymarch Park, Quincy, MA, USA, 02269.

LEVELLING AND ANCHORING THE APPLIANCE

1. Place appliance in the installation position.
2. Place a carpenter's level on top of the appliance and turn the adjustable feet to level side-to-side and front-to-back.
3. Mark hole locations on the floor through the anchoring holes provided in the rear flanged adjustable feet.
4. Remove appliance from installation position and drill holes in locations marked on the floor. (See *SERVICE CONNECTIONS* Section.) Insert proper anchoring devices (not supplied).
5. Place appliance back in the installation position.
6. Place carpenter's level on top of appliance and re-level side-to-side and front-to-back.
7. Bolt and anchor appliance securely to the floor.
8. Seal bolts and flanged feet with silastic or equivalent compound.

ELECTRICAL CONNECTIONS

⚠ WARNING

Electrical and grounding connections must comply with the applicable portions of the National Electrical Code and/or other local electrical codes.

⚠ WARNING

Electrical and grounding connections must comply with the applicable portions of the National Electrical Code and/or other local electrical codes.

When making electrical connections, use copper wire suitable for at least 200EF (90EC). The steamer must be grounded in accordance with the National Electrical Code or applicable local codes. The wiring diagram is located on the inside of the right panel.

EXHAUST Hood

An exhaust system should be located directly above the Steamer to exhaust steam and heat generated by the appliance.

INFORMATION TO STEAM FITTER

Each cooking compartment requires approximately 2.5 BHP (86.25 lbs. of steam per hour minimum) to operate satisfactorily.

Assuming availability of 30 psi supply steam pressure immediately to the appliance, then pipe sizes of 1/2" or 3/4" or 1" will deliver respectively 90, 165, or 385 lbs. of steam per hour to the appliance. From the foregoing to use 1/2" pipe line would most likely prove inadequate.

An extremely important consideration is the pressure drop that will occur through the steam supply line from its point of origin to the appliance. The greater the length of piping and number of valves and elbows, the greater the pressure losses.

Consider a pressure drop of 1 (one) psi for each straight length of pipe equivalent to 120 diameters of that pipe. Thus, a 1" pipe having a straight length of 120" (10 feet) is equivalent to 120 diameters of that pipe and will have a pressure loss of 1 psi through that pipe.

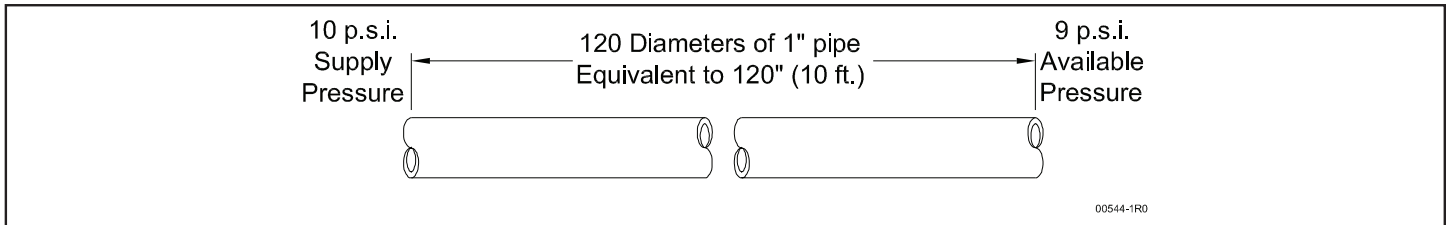

NOTE: in 3/4" pipe size, that a Standard 90E Elbow, an Angle Valve and a Globe Valve are equivalent to 1.8 feet, 10 feet and 18 feet respectively of straight pipe. Similarly, in 1" pipe size, a standard 90E elbow, and Angle Valve and a Globe Valve are equivalent to 2.2 feet, 12 feet and 23 feet respectively of straight pipe.

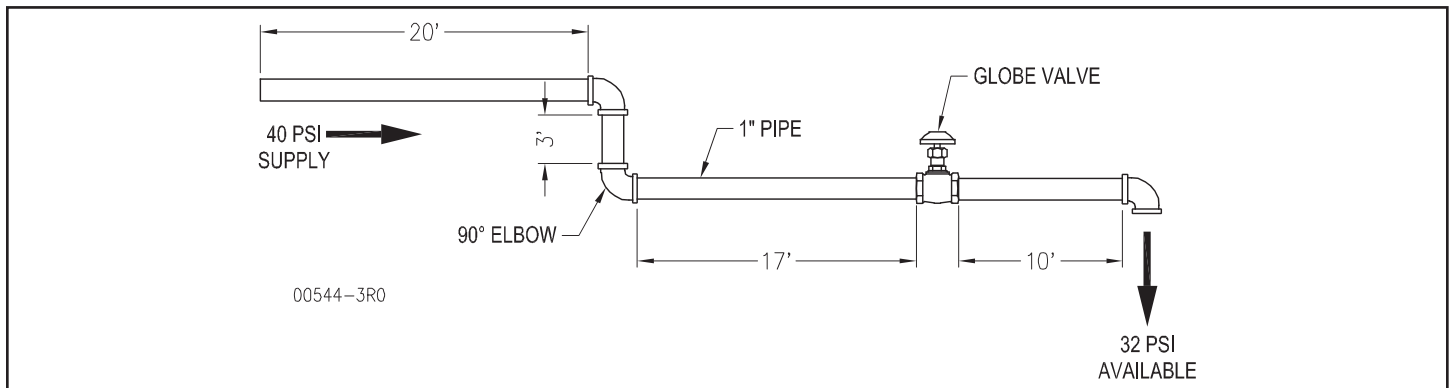

Total of above = 20 + 2.2 + 3 + 2.2 + 17 + 23 + 10 + 2.2 + 79.6 feet. Since each 10 foot is equivalent to 1 psi pressure loss, 79.6 feet is equivalent to approximately 32 psi from an original boiler supply of 40 psi.

It is suggested that, wherever possible, the steam supply line to the appliance be a separate line from the steam source. If the appliance must be supplied from a line supplying other appliances, the pipe sizes and pressure will have to be verified. Further, during idle periods, when the steam in the supply line is not in use, water will form from condensed steam in the supply line and it is advisable to prevent water pockets from forming in the steam line and impeding the steam flow when it is required. Therefore, contrive to have the steam supply line level or run slightly downwards towards the appliance. Install a Ball Float Trap near the appliance to drain out water (condensed steam) from the line to assure clean dry steam to the appliance.

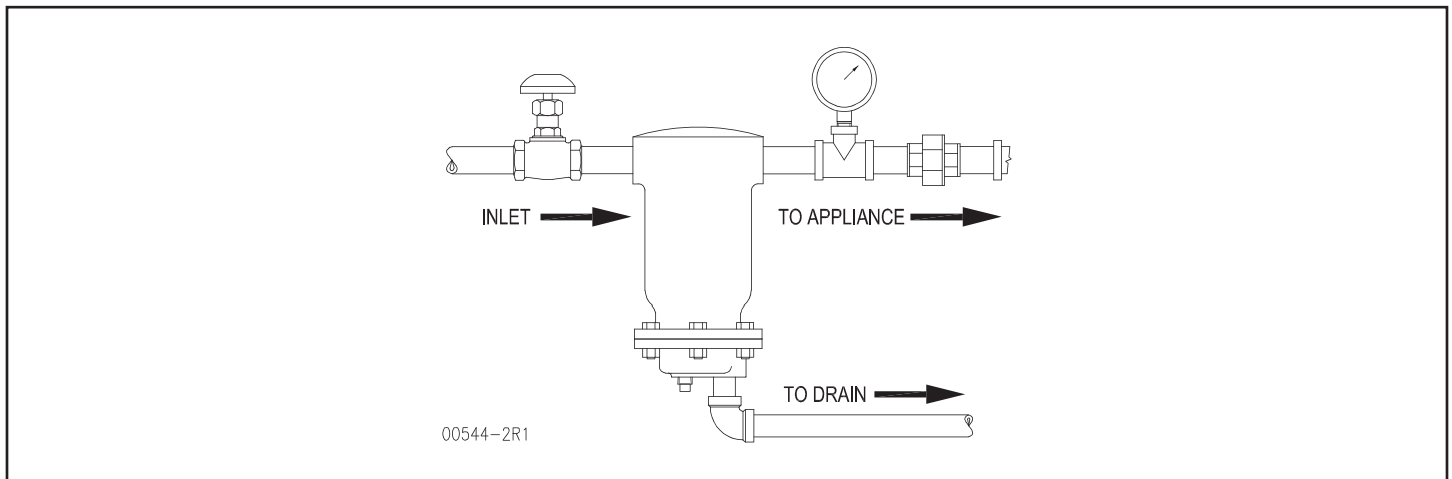

PLUMBING CONNECTIONS (See *SERVICE CONNECTIONS* Section)

Water Supply Connection

WARNING

Plumbing connections must comply with applicable sanitary, safety, and plumbing codes.

The incoming cold water supply connection, at the rear of the steamer cabinet, requires 3/8" tubing and water pressure of 25 - 50 psig. A manual shut-off valve must be provided convenient to the appliance. This valve should be open when the steamer is in operation.

Drain Connection

The steamer drain (2" IPS) should be piped to a floor drain near the steamer (NOT directly under the steamer). There should be no solid drain connection; an "open gap" between the steamer and the floor drain is required.

OPERATION

CAUTION

Live steam and accumulated hot water in the compartment may be released when the door is opened.

START-UP

Start-up procedures for your steamer must be completed once daily prior to operation.

1. Turn on the water and steam supply to the appliance.
2. Open the cabinet door and turn the power switch to ON. A pilot light comes on indicating the appliance is ready to begin operation. With the READY pilot light on, preheat steamer compartment for one minute when the steamer is to be first used for the day or whenever the compartment is cold.

If appliance is equipped with optional - "Load Compensating Timer" a pre-heat thermostat is installed in each compartment. This allows the compartment to pre-heat to 185EF before the cooking time starts. Set timer for one minute. Ready light will go out and cook light will come on; steam will enter compartment. Once compartment has reached the pre-heat temperature (185EF) the timer will start. After the time selected has elapsed, buzzer will sound indicating the end of the cooking cycle. Steam generation will cease, Cook light will go out and Ready light will come on. To silence buzzer turn timer to its off position.

OPERATION

1. With cooking compartment preheated and ready pilot light on, place pans of food to be cooked into compartment and shut door.
2. Set timer to cooking time desired. Cooking cycle may be interrupted at any time by opening door and resumed again by closing door.
3. When buzzer sounds, it indicates the end of the cooking cycle and that no more steam is entering the compartment. Cooking pilot light will go off and ready pilot light will come on. Buzzer must be shut off by turning the timer to its off position.

CAUTION

An obstructed drain can cause personal injury or property damage.

Frequently check that the compartment drain and plumbing is free of all obstructions. Never place food containers, food or food portion bags in the cooking compartment in such a way that the compartment drain becomes obstructed.

IMPORTANT

If your equipment was supplied with split water lines and a filter, connect the filter system to the connection marked "BOILER FEED" only. Make a second connection to the "CONDENSER FEED" from a cold and unfiltered water supply.

SHUT DOWN

1. To shut down cooking compartment, set timers to their OFF position and leave doors slightly open.
2. At the end of the day, open the door of the cabinet base and turn off the power switch. Turn off external steam supply valve.

CLEANING

 **WARNING**

Never spray water into electric controls.

 **CAUTION**

Do not use cleaning agents that are corrosive.

 **CAUTION**

Live steam and accumulated hot water in the compartment may be released when the door is opened.

 **CAUTION**

Disconnect the power supply during cleaning or servicing.

1. Keep exposed cleanable areas of unit clean at all times.
2. Thoroughly wash oven cavities, door liners, and pan racks at the end of each day, or as required, with a mild detergent and water to prevent bacterial growth and odors.
3. Remove drain screens from inside compartment drains. Using a plastic bottle brush and mild detergent, clean inside the drain opening ensuring there is no food residue or blockage. Clean the drain screen and replace in its original position.
4. Wash gasket sealing surface daily with mild detergent to remove harmful food acids.
5. Rinse entire unit and dry. DO NOT GET WATER in electrical box or any electrical component.

TROUBLESHOOTING

NOTICE

Contact the factory, the factory representative or local service company to perform maintenance and repairs. Refer to warranty terms.

NOTICE

At least twice a year have an authorized service person clean and adjust the unit for maximum performance.

DOOR LEAKS

1. Check for damage to door gasket.
2. Gasket may be adjusted if necessary by turning the screws counter clockwise in the gasket plate.

WATER ACCUMULATES IN THE COMPARTMENT

1. Compartment drain screen clogged. Remove and clean thoroughly and replace.

COOKING CHART

The following table lists suggested cooking times and weights. These times, which will vary depending on initial product temperature, size, shape, etc., are approximate and should be adjusted to suit your operation.

PRODUCTS TO BE COOKED IN SOLID PANS

PRODUCT	TIMER SETTING (MINUTES)	WEIGHT PER PAN
Eggs, Scrambled	10 - 12	8 Dozen
Rice, Long Grain (Cover with 4 cups water per pound.)	25	2 lb.
Pasta (Place perforated pan inside solid pan, cover pasta with cold water.)		
Spaghetti, Regular/Vermicelli	12 - 15	
Macaroni, Shells/Elbows	15 - 18	
Noodles, ½" wide	12 - 15	
Lasagna Noodles	15 - 18	
Frozen Casseroles, Lasagna	35	Full Pan
Meat Loaf, 3 - 5 pounds each	40	15 lb.
Beef		
Ground Chuck	20 - 25	10 lb.
Sliced as Purchased	35 - 40	10 lb.
Shrimp, Frozen, 10 per pound	5	4 lb.
Beans		
Baked	9	10 lb. Can
Refried	9	10 lb. Can
Canned Vegetables	6	10 Lb Can
Prunes, Dried	12 to 15	
Clams		
Frozen	10 - 12	3 Doz.
Fresh, Cherrystone	5 - 6	3 Doz.
King Crab, Frozen		
Claws	4	2-1/2 lb.
Legs	4 - 6	4-1/2 lb.
Lobster Tail, Frozen	6	10 lb.
Lobster, Live, 10 - 12"	5	4 Per Pan
Salmon Fillets, Frozen, 8 ounces each	5	7-1/2 lb.
Scallops, Fresh	4	3 lb.
Scrod Fillets, Fresh	3 - 5	4 lb.
Eggs		
Hard Cooked	15	4 Doz.
Soft Cooked	9 - 10	4 Doz.
Soft Yolk for Caesar Salad	6 - 8	4 Doz.
Chicken - Breasts, Legs, Thighs	20	15 lb.
Turkey, Frozen		
Breasts (2)	90	6 - 7 lb. Each
Cut Lengthwise	55	20 - 25 lb.
Corned Beef	40 - 75	6 - 8 lb.

PRODUCT	TIMER SETTING (MINUTES)	WEIGHT PER PAN
Hot Dogs or Wieners	3	80 - 100 Count
Asparagus Spears Frozen Fresh	10 - 12 5	3 Doz. 5 lb.
Beans Green, 2" Cut, Frozen/Fresh Lima, Frozen Baby Lima, Frozen	6 8 5	5 lb. 5 lb. 5 lb.
Brussel Sprouts, Frozen	6	5 lb.
Broccoli Spears, Frozen Spears, Fresh Florets, Frozen	8 6 6	4 lb. 5 lb. 5 lb.
Cabbage, Fresh, 1/6 Cut	8	5 lb.
Carrots Baby Whole, Frozen Crinkle Cut, Frozen Sliced, Fresh	8 7 - 8 11	7 lb. 4 lb. 9 lb.
Cauliflower, Flowerettes Frozen Fresh	6 7 - 8	4 lb. 5 lb.
Celery, 1" Diagonal Cut	7	5 lb.
Corn Yellow Whole Kernel, Frozen Cobbettes, Frozen Corn-On-Cob, Fresh	5 8 16 - 18 10 - 12 16 - 18	5 lb. 27 Ears 80 Ears 18 Ears 54 Ears
Peas, Green	6	5 lb.
Potatoes, Whole Russet	55	40 lb.
Spinach Chopped, Frozen Defrosted Fresh Cut	17 5 3	6 lb. 6 lb. 2 lb.
Squash, Acorn Halves	25	10 Halves
Zucchini, Slices	8	10 lb.
Frozen Mixed Vegetables	6 - 7	5 lb.
Fruit, Blanch for Peeling, Grapefruit Oranges	3	
Pineapple, Whole for Cutting	4	

COOKING HINTS

Where possible, spread food out evenly in pans. Do not allow food to protrude above pans, since this will interfere with steam circulation between pans in the compartment.

Always preheat compartments for satisfactory results. When time does not allow for defrosting of frozen vegetables, such as loose-pack peas, corn, diced carrots, etc., they may be cooked at once provided just half of the suggested portions in the cooking chart are used.

DCX-16 & DCX-24

Direct Steam Convection Steamer



A product with the Crown name incorporates the best in durability and low maintenance. We all recognize, however, that replacement parts and occasional professional service may be necessary to extend the useful life of this appliance. When service is needed, contact a Crown Authorized Service Agency, or your dealer. To avoid confusion, always refer to the model number, serial number, and type of your appliance.



CROWN FOOD SERVICE EQUIPMENT

 A Middleby Company

70 Oakdale Road, Downsview (Toronto) Ontario, Canada, M3N 1V9
Telephone: 919-762-1000 www.crownsteamgroup.com