



IMPORTANT FOR FUTURE REFERENCE
Please complete this information and retain this manual for the life of the equipment:

Model #: _____
Serial #: _____
Date Purchased: _____

INSTALLATION & OPERATION MANUAL

Direct Steam Single and Twin Mixer Kettles DLTM-40-(2) DLTM-60-(2) DLTM-80-(2) DLTM-100-(2)

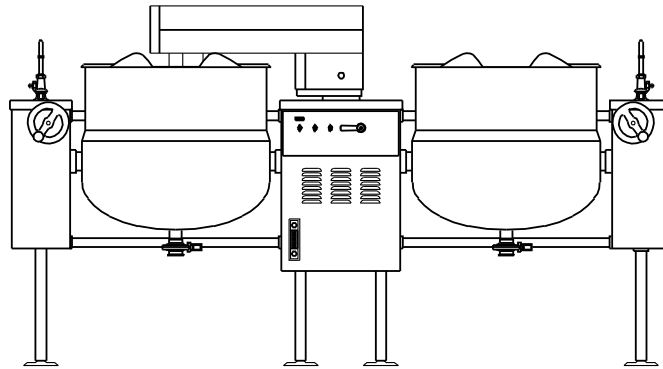
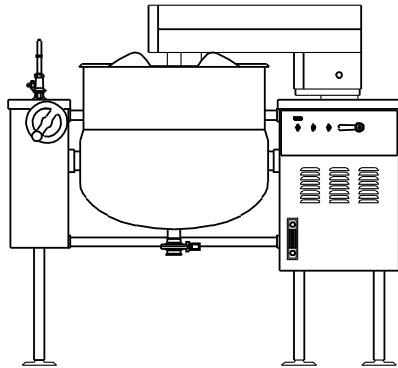

⚠ WARNING

Improper installation, adjustment, alteration, service or maintenance can cause property damage, injury or death. Read the installation, operating and maintenance instructions thoroughly before installing or servicing this equipment.

CROWN FOOD SERVICE EQUIPMENT

 A Middleby Company

70 Oakdale Road, Downsview (Toronto) Ontario, Canada, M3N 1V9
Telephone: 919-762-1000 www.crownsteamgroup.com

Printed in Canada



INSTALLATION AND OPERATION MANUAL, DIRECT STEAM SINGLE & TWIN MIXER
KETTLE, MODELS DLTM-40 TO DLTM-100 AND DLTM-40-2 TO DLTM-100-2

1.0 IMPORTANT NOTES FOR INSTALLATION AND OPERATION

It is recommended that this manual be read thoroughly and that all instructions be followed carefully.

	<p>This is the safety alert symbol. It is used to alert you to potential personal injury hazards. Obey all safety messages that follow this symbol to avoid possible injury or death.</p>
---	--

	<p>WARNING: Improper installation, operation, adjustment, alteration, service or maintenance can cause property damage, injury or death. Read the installation, operating and maintenance instructions thoroughly before installing, operating or servicing this equipment.</p>
---	--

Intended for commercial use only. Not for household use.

This manual should be retained for future reference.

INSTALLATION AND OPERATION MANUAL, DIRECT STEAM SINGLE & TWIN MIXER
KETTLE, MODELS DLTM-40 TO DLTM-100 AND DLTM-40-2 TO DLTM-100-2

TABLE OF CONTENTS

DESCRIPTION	PAGE
1.0 Important Notes for Installation and Operation	2
2.0 Service Connections	4
3.0 Introduction	6
4.0 Installation Instructions	7
5.0 Operating Instructions	8
6.0 Cleaning Instructions	10
7.0 Maintenance	13
8.0 Troubleshooting	17
Appendix A, Material Safety Data Sheet	21

INSTALLATION AND OPERATION MANUAL, DIRECT STEAM SINGLE & TWIN MIXER KETTLE, MODELS DLTM-40 TO DLTM-100 AND DLTM-40-2 TO DLTM-100-2

2.0 SERVICE CONNECTIONS

<p>⚡ - ELECTRICAL CONNECTION; to be as specified on data plate.</p> <p>☁ - STEAM SUPPLY; 3/4"IPS.</p> <p>💧 - COLD WATER; 3/8" O.D. tubing to faucet (OPTIONAL)</p> <p>🔄 - CONDENSATE RETURN; 1/2"IPS.</p> <p>🛢️ - OIL COOLER WATER IN ; 3/8" Tube Bulkhead Union.</p> <p>🛢️ - OIL COOLER WATER OUT ; 3/8" Tube Bulkhead Union.</p>
--

ELECTRICAL CHARACTERISTICS

ALL MODELS	AMPS PER PHASE							
	PHASE	208V	220V	240V	380	415	480V	600
	3	14.0	13.5	12.5	8.0	7.5	6.5	5.0

DIMENSIONS

MODEL	CAPACITY		A	B	C	D	E	F	G	H	J	K
DLTM-40	40 gallons	Inches	26	62	43.25	55	75.625	14.75	56	23.75	35	11
	152 litres	mm	660	1575	1099	1397	1921	375	1422	603	889	279
DLTM-60	60 gallons	Inches	29.5	65	49	58.5	80	19	58	28.13	39.38	15.38
	227 litres	mm	749	1651	1245	1486	2032	483	1473	714	1000	391
DLTM-80	80 gallons	Inches	33	67.75	49	58.5	80	19	60	28.13	39.38	15.38
	303 litres	mm	838	1721	1245	1486	2032	483	1524	714	1000	391
DLTM-100	100 gallons	Inches	35.5	70	49	58.5	85	19	63	28.13	39.38	15.38
	379 litres	mm	902	1778	1245	1486	2159	483	1600	714	1000	391

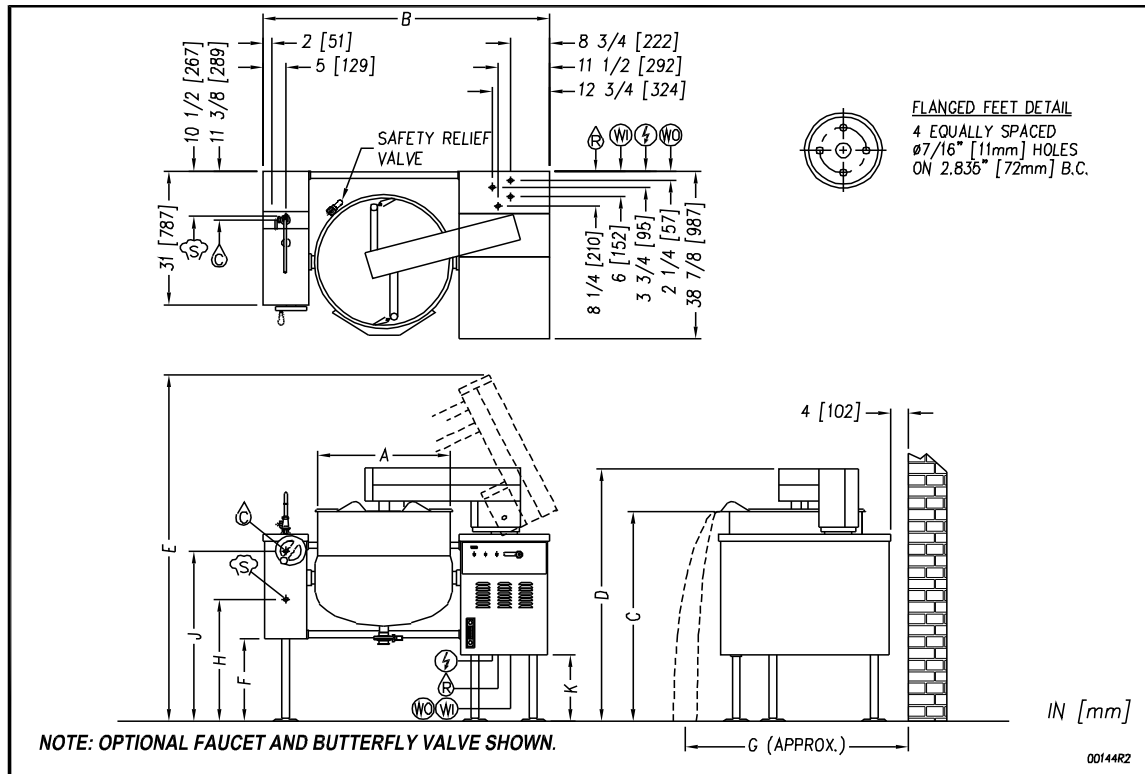

As continued improvement is a policy of Crown, specifications are subject to change without notice.

INSTALLATION AND OPERATION MANUAL, DIRECT STEAM SINGLE & TWIN MIXER KETTLE, MODELS DLTM-40 TO DLTM-100 AND DLTM-40-2 TO DLTM-100-2

2.0 SERVICE CONNECTIONS

- ⊞ — STEAM SUPPLY: 3/4" IPS
- ⊚ — ELECTRICAL CONNECTION; to be as specified on data plate.
- ⊕ — COLD WATER - 3/8" nominal tubing to kettle fill faucet (OPTIONAL)
- ⊖ — Condensate return 1/2" IPS
- ⊗ — OIL COOLER WATER IN : 3/8" Tube bulkhead Union.
- ⊘ — OIL COOLER WATER OUT : 3/8" Tube bulkhead Union.

ELECTRICAL CHARACTERISTICS

ALL MODELS	AMPS PER PHASE							
	PHASE	208V	220V	240V	380	415	480V	600
	3	14.0	13.5	12.5	8.0	7.5	6.5	5.0

DIMENSIONS

MODEL	CAPACITY		A	B	C	D	E	F	G
DLTM-40-2	40 gallons	Inches	26	102	43.25	55	75.625	15.125	56
	152 litres	mm	660	2591	1099	1397	1921	384	1422
DLTM-60-2	60 gallons	Inches	29.5	108	49	58.5	80	19.5	58
	227 litres	mm	749	2743	1245	1486	2032	495	1473
DLTM-80-2	80 gallons	Inches	33	116	49	58.5	80	19.5	60
	303 litres	mm	838	2946	1245	1486	2032	495	1524
DLTM-100-2	100 gallons	Inches	35.5	121	49	58.5	85	19.5	63
	379 litres	mm	902	3073	1245	1486	2159	495	1600

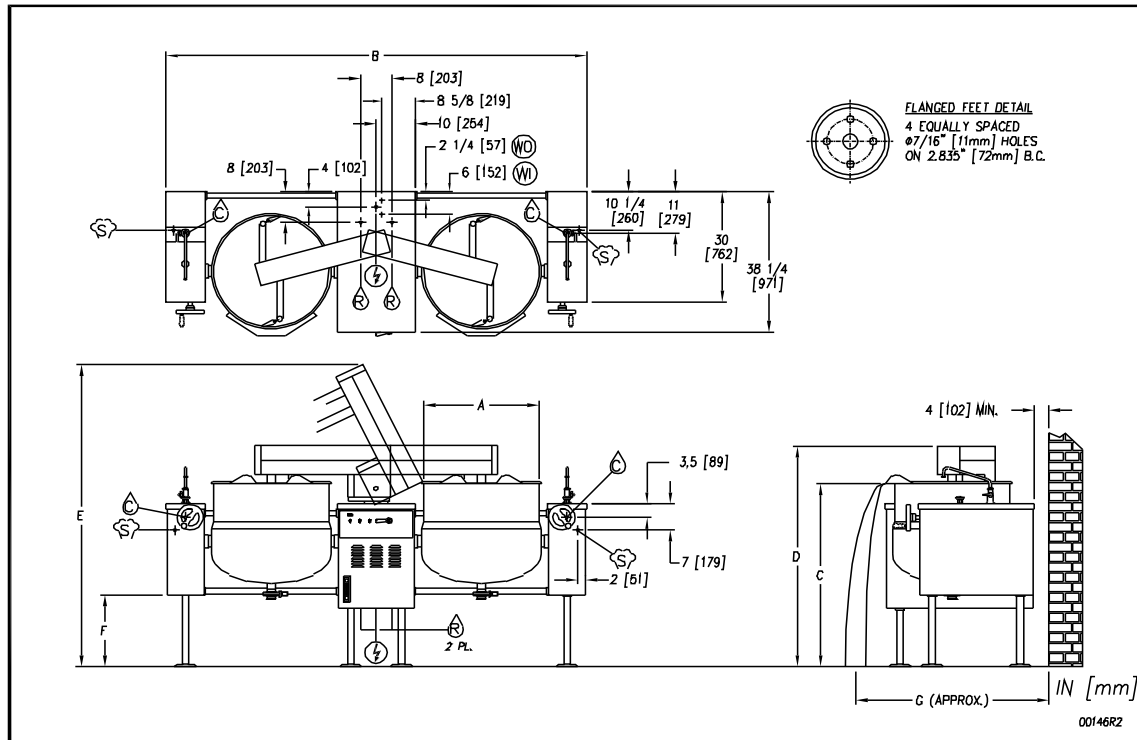

As continued improvement is a policy of Crown, specifications are subject to change without notice.

INSTALLATION AND OPERATION MANUAL, DIRECT STEAM SINGLE & TWIN MIXER
KETTLE, MODELS DLTM-40 TO DLTM-100 AND DLTM-40-2 TO DLTM-100-2

3.0 INTRODUCTION

DESCRIPTION

All Crown direct connected steam jacketed kettles pertaining to this manual are direct steam operated pressure vessels of a double-wall stainless steel construction forming a steam chamber (jacket) enveloping the lower two thirds of the kettle bowl surface. All kettles are tilting, floor mounted in fixed positions on legs with adjustable flanged feet. All kettles are equipped with a safety relief valve and a steam control valve.

CAPACITIES

All models are suffixed with either -40, -60, -80 or -100 to indicate the capacity of that kettle in US gallons. Thus a DLTM-40 is a two thirds jacketed direct steam kettle mounted on legs with a capacity of 40 gallons (US).

FUNCTIONING MODE

Crown direct connected steam jacketed kettles consist of a stainless steel bowl and a stainless steel jacket which envelopes two thirds of the lower surface of the bowl thus forming a sealed pressure vessel (chamber) into which steam is introduced by means of a manual control valve.

The kettle bowl is the container for the food product which ideally should be of a liquid or semi-liquid consistency to achieve complete contact with the bowl surface and thus fully absorb the heat transmitted through that surface.

The temperatures required for the cooking process to function adequately must be greater than the boiling point of the liquid food product. Further, the greater the steam pressure used, the higher the temperature and consequently the quicker the cooking process. For example, steam pressurized at 30 psi attains a temperature of 274 degrees Fahrenheit (135 Celsius).

In the initial stages of the cooking process when the steam comes in contact with the cold kettle bowl surface it condenses and forms considerable amounts of water. A thermostatic steam trap should be plumbed to the exit end of the kettle jacket. This trap is a mechanical device that closes on high temperatures and opens when the temperature drops thus allowing the water formed from condensate to exhaust but retain steam under pressure.

INSTALLATION AND OPERATION MANUAL, DIRECT STEAM SINGLE & TWIN MIXER
KETTLE, MODELS DLTM-40 TO DLTM-100 AND DLTM-40-2 TO DLTM-100-2

4.0 INSTALLATION INSTRUCTIONS

The kettle must be installed in accordance with State and/or local codes. In the USA, the National Electrical code, ANSI/NFPA-70 (latest edition). In Canada, the Canadian Electrical Code, Part 1, CSA Standard C22.1 (latest edition).

1. Select a location to provide drainage for kettle pour path when tilted and for butterfly valve if so equipped. Allow sufficient rear clearance from wall for access to rear service panel on hydraulic console.
2. Level unit. Mark anchoring hole locations through flanged adjustable feet.
3. Remove unit and drill holes as marked and, insert expansion shields to accommodate 5/16" size lag bolts.
4. Reposition unit. Re-check level.
5. Bolt down unit and seal bolts with Silastic or equivalent sealing compound. Sealant must be applied not only to bolt heads but also around flanges making contact with the floor surface to fulfil NSF requirements. Wipe off excess sealant immediately.
6. Connect steam line (3/4" pipe size) to the steam inlet. Make sure there is a steam control valve strainer convenient to the unit. If incoming steam pressure is greater than kettle maximum operating pressure, then a pressure reducing valve must be installed in the line. If large amounts of water accumulate in the steam line it will be necessary to install one or more ball float traps in the line to eliminate the water. A steam line pressure gauge is also recommended to determine the actual amount of steam coming to the kettle.
7. Connect the condensate return line to a drain or to the boiler return line. Return line must have a check valve.
8. Connect cold water supply line as indicated in bottom of hydraulic console.
9. A control box with a power supply equivalent to the electrical rating of the unit should be located nearby. A waterproof electrical connection for the power supply to the unit must be provided.
10. Connect power supply as indicated.
11. Relief valves on the kettles must not be adjusted or closed off as they are set to relieve excess pressure in the kettles.
12. Do not make any adjustments to the hydraulic valves as they have all been adjusted at the factory.
13. Turn unit on when electrically connected, and check for proper operation.

INSTALLATION AND OPERATION MANUAL, DIRECT STEAM SINGLE & TWIN MIXER
KETTLE, MODELS DLTM-40 TO DLTM-100 AND DLTM-40-2 TO DLTM-100-2

5.0 OPERATING INSTRUCTIONS

OPERATION OF KETTLES

1. If kettle has a butterfly valve close it.
2. Fill kettle with product to desired level.
3. Slowly turn the steam control valve ON to full open position (counterclockwise).
4. The water or food should boil 3 to 4 minutes per gallon. If it does not then incoming pressure should be checked to determine that it is adequate to operate the kettle efficiently.
5. Regulate steam control valve depending on type of food being prepared.
6. When food is cooked, turn off steam, remove food and clean kettle immediately to prevent residue from drying on kettle bowl surface.

OPERATION OF MIXER UNIT

Power to operate the mixer unit is controlled by the “Main Power” switch located on the left side of the control panel. Place switch in the “ON” position. Ensure that mixer “speed” control is set to the “stop” position. Set the mixer switch, located beside the main power switch, to “ON” position. Note that the agitators should not be turning. The speed control has four basic settings which are: stop, slow, medium and fast. Set the speed control to the slow position and observe that the agitators turn.



WARNING: Never place hands inside kettle when agitators are in motion.

Increasing the speed setting on the control will increase the speed at which the agitators turn.

NOTE: Always start agitators at the slow speed and then gradually increase to the desired speed to avoid splashing or “throwing” the product over edge of kettle.

TO RAISE MIXER BRIDGE

To tilt kettle for emptying or to clean agitators, the mixer bridge will tilt hydraulically upward and manually swing clear of the kettle. To do this, first turn speed control to “STOP” and then turn mixer switch to “OFF.”

INSTALLATION AND OPERATION MANUAL, DIRECT STEAM SINGLE & TWIN MIXER
KETTLE, MODELS DLTM-40 TO DLTM-100 AND DLTM-40-2 TO DLTM-100-2

5.0 OPERATING INSTRUCTIONS (Continued)



NOTE: Mixer agitator arms must be stopped at 90 degrees to the mixer bridge before raising the bridge. If the agitator arms do not stop in this position when speed selector is set to stop, then “jog” the selector on and off to achieve this position.

Push and hold the “TILT” switch in the “RAISE” position. Bridge will raise to maximum height. Bridge will stop at any position if the tilt switch is released and will remain in that position until switch is pushed to either raise or lower. When the bridge is fully raised it can be manually turned to the side to clear kettle.

NOTE: The bridge is equipped with a safety switch which prevents turning of the agitators, regardless of the mixer switch, or speed control settings. Agitators will not engage unless the bridge is lowered so that the guide pin rests fully in the guide pin bracket on the side of the kettle.

REMOVAL OF AGITATORS

For ease of cleaning, the agitators are removable without tools. To remove, raise bridge as described above and swing clear of kettle. Grasp shaft of large agitator, push up and turn to disengage lock pin. Pull straight down on agitator. Remove the small agitator in the same manner. Soak and wash agitators in warm, soapy water. Never use abrasive cleansers or scouring pads on the stainless steel surfaces as this will damage the finish of the stainless steel.

If it is necessary to remove the scraper blades from the large agitator for cleaning purposes, do so by removing the pin at the end of the mounting shaft and then slide the scraper blades off of the shaft.

To clean the exterior stainless steel panels of your unit, use a damp soft cloth or soft cloth and stainless steel cleaner. Never use abrasive cleansers or scouring pads on the stainless steel surfaces as this will damage the finish of the stainless steel.

INSTALLATION AND OPERATION MANUAL, DIRECT STEAM SINGLE & TWIN MIXER
KETTLE, MODELS DLTM-40 TO DLTM-100 AND DLTM-40-2 TO DLTM-100-2

6.0 CLEANING INSTRUCTIONS



WARNING: Disconnect the power supply to the appliance before cleaning or servicing.



WARNING: Never spray water into electric controls or components!



CAUTION: The equipment and its parts are hot. Use care when operating, cleaning and servicing the appliance.



CAUTION: Do not use cleaning agents that are corrosive.

Your kettle should be cleaned immediately after each use.

1. Ensure that steam supply is OFF.
2. Pre-rinse inside of kettle thoroughly and drain to remove any food particles.
3. Using a nylon brush, clean kettle with a mild detergent and warm water rinse. Never use steel wool or scouring powder as it will scratch stainless steel.
4. Tilt kettle fully or open the tangent draw-off valve if one is provided to allow soap and water solution to drain. Rinse with clean water.
5. Wipe the exterior of kettle with a clean, damp cloth.

Use of cleaning agents that contain chloride, acids or salts are corrosive and may cause pitting and corrosion when used over a period of time; this will reduce the life of the appliance.

Should pitting or corrosion occur, this is not covered by warranty.

Use a mild detergent, warm water and rinse thoroughly.

INSTALLATION AND OPERATION MANUAL, DIRECT STEAM SINGLE & TWIN MIXER
KETTLE, MODELS DLTM-40 TO DLTM-100 AND DLTM-40-2 TO DLTM-100-2

6.0 CLEANING INSTRUCTIONS (Continued)

WHAT TO DO IF SURFACE RUST APPEARS

Metal utensils should never be used as they will scratch the surface of the equipment and rust may begin to form. To remove surface accumulation of rust from inadvertent use of such utensils, the following procedure may be used.



CAUTION: Improper use of this procedure may damage your appliance!

1. Use undiluted white vinegar with a non-abrasive scouring pad (plastic) or cloth on the affected area to remove the rust stain. The appliance should not be heated and remain at room temperature during the entire cleaning process.
2. If the stain resists removal, additional exposure time with vinegar may be required, to a maximum of one hour.
3. Thoroughly wash all of the vinegar away with fresh clear water. Dry the surface completely and allow one hour before using the appliance to cook.

Following daily and period maintenance procedures will prolong the life of your equipment. Climatic conditions - salt air - may require more thorough and frequent cleaning or the life of the equipment could be adversely affected.

STAINLESS STEEL

To remove normal dirt, grease or product residue from stainless steel, use ordinary soap and water (with or without detergent) applied with a sponge or cloth. Dry thoroughly with a clean cloth. Never use vinegar or any other corrosive cleaner.

To remove grease and food splatters or condensed vapours that have baked on the equipment, apply cleanser to a damp cloth or sponge and rub cleanser on the metal in the direction of the polishing lines. Rubbing cleanser as gently as possible in the direction of the polished lines will not mar the finish of the stainless steel. **NEVER RUB WITH A CIRCULATION MOTION.**

Soil and burn deposits which do not respond to the above procedure can usually be removed by rubbing the surface with **SCOTCH-BRITE™** scouring pads or **STAINLESS** scouring pads. **DO NOT USE ORDINARY STEEL WOOL** as any particles left on the surface will rust and further spoil the appearance of the finish. **NEVER USE A WIRE BRUSH, STEEL SCOURING PADS (EXCEPT STAINLESS), SCRAPER, FILE OR OTHER STEEL TOOLS.** Surfaces which are marred collect dirt more rapidly and become more difficult to clean. Marring also increases the possibility of corrosive attack. Refinishing may then be required.

INSTALLATION AND OPERATION MANUAL, DIRECT STEAM SINGLE & TWIN MIXER
KETTLE, MODELS DLTM-40 TO DLTM-100 AND DLTM-40-2 TO DLTM-100-2

6.0 CLEANING INSTRUCTIONS (Continued)

TO REMOVE HEAT TINT: Darkened areas sometimes appear on stainless steel surfaces where the area has been subjected to excessive heat. These darkened areas are caused by thickening of the protective surface of the stainless steel and is not harmful. Heat tint can normally be removed by the foregoing, but tint which does not respond to this procedure calls for a vigorous scouring in the direction of the polish lines using **SCOTCH-BRITE™** scouring pads or a **STAINLESS** scouring pad in combination with a powdered cleanser. Heat tint action may be lessened by not applying or by reducing heat to equipment during slack periods.

All food contact surfaces must be thoroughly drained and flushed prior to cooking in the kettle.

CONTROL PANEL: The textured control panel should be cleaned with warm water and mild soap. Never use an abrasive cloth or steel wool. Never use cleaning solvents with a hydrocarbon base.

BUTTERFLY VALVE



WARNING: If you are cleaning a valve that is assembled to a kettle, be sure the kettle is completely empty of any product.

DISASSEMBLY AND MAINTENANCE

In the event that repairs or replacement becomes necessary, the following procedures are suggested.

1. Drain and flush the piping surrounding the valve.
2. To remove handle, remove the socket head screw found on top of the valve handle with proper size Allen wrench.
3. Remove the nut and cap screws.
4. Separate the valve body halves.
5. Set the butterfly disc to the open position.
6. Squeeze the seal until oval shaped, then slide the short end of the stem from the seal.
7. Pinch the disc between the thumb and forefinger and pull the long end of the stem.
8. Check for and replace a cracked or worn seal, bushing, stem and disc, or screws.
9. Reassembly is opposite of disassembly.

7.0 MAINTENANCE

KETTLE

NOTICE: Contact the factory, the factory representative or local service company to perform maintenance and repairs.

SAFETY VALVE MAINTENANCE AND TESTING



CAUTION! Under normal operating conditions a “try lever test” should be performed every two months. Under severe service conditions, or if corrosion and/or deposits are noticed within the valve body, testing must be performed more often. A “try lever test” should also be performed at the end of any non-service period.



CAUTION! Hot, high pressure fluid may be discharged from body drain and vent during “try lever” test. Care must be taken to avoid any bodily contact.



CAUTION! High sound levels may be experienced during “try lever” test. Wear proper safety equipment and exercise extreme care! Test at, or near, half of the operating pressure by holding the test lever fully open for at least two seconds to flush the valve seat free of sediment and debris. Then release lever and permit the valve to snap shut.

If lift lever does not activate, or there is no evidence of discharge, turn off equipment immediately and contact a licensed contractor or qualified service personnel.

INSTALLATION AND OPERATION MANUAL, DIRECT STEAM SINGLE & TWIN MIXER
KETTLE, MODELS DLTM-40 TO DLTM-100 AND DLTM-40-2 TO DLTM-100-2

7.0 MAINTENANCE (Continued)

HYDRAULIC SYSTEM

Use "FM Hydraulic Oil 32" or equivalent oil - Fluid Level: 13.62 U.S. Gallons.

SERVICE

Set up regular schedule for checking the oil temperature, hydraulic hoses and keeping the equipment clean. A thick layer of dirt acts as an insulation and prevents the hydraulic system from properly cooling.

The hydraulic system has been adjusted and tested at the factory and no adjustment should be needed. If the unit fails to operate properly, all service work must be performed by a qualified service agent.

A thermostat controlled cooling system has been installed in the hydraulic system to maintain cool oil temperatures while in operation. The oil is cooled by cold water flowing through a heat exchanger along side of the oil. Thermostat activates at 140° F oil temperature, releasing cold water into the heat exchanger and cooling the oil.

INSTALLATION AND OPERATION MANUAL, DIRECT STEAM SINGLE & TWIN MIXER
KETTLE, MODELS DLTM-40 TO DLTM-100 AND DLTM-40-2 TO DLTM-100-2

7.0 **MAINTENANCE** (Continued)

SETTING UP HYDRAULIC SYSTEM FOR MIXING KETTLES

A. SETTING MIXER SYSTEM PRESSURE

1. On the operator panel, switch "POWER" to on, "MIXER" to on, and set mixer speed to "STOP".
2. Turn trim relief stem, item "B", completely in.
3. Increase the pump pressure by turning "A" inwards, until gauge "D" reads 1700 psi. The pressure must be 300 psi higher than the pump setting.
4. Adjust trim relief "B" outwards until pressure indicated on gauge "D" begins to drop.
5. Lock the trim relief "B".
6. Decrease the pump pressure by turning "A" outwards, until gauge "D" reads 1400 psi and lock in place.

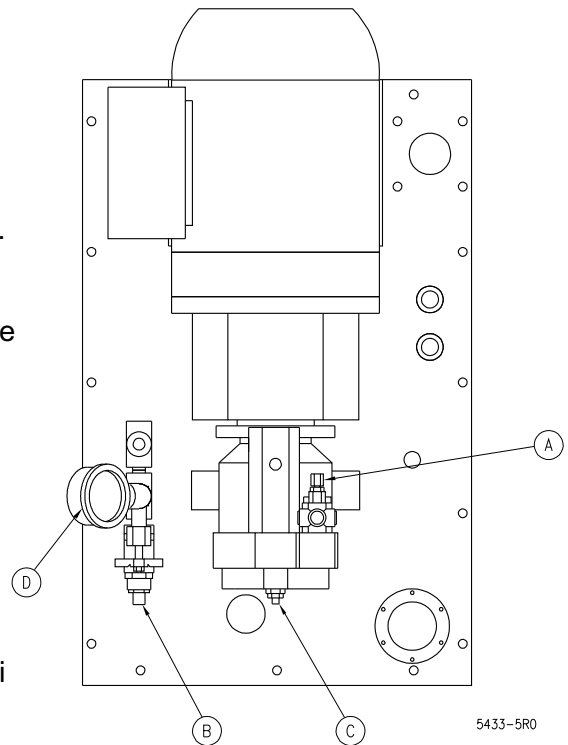

Figure 2

INSTALLATION AND OPERATION MANUAL, DIRECT STEAM SINGLE & TWIN MIXER
KETTLE, MODELS DLTM-40 TO DLTM-100 AND DLTM-40-2 TO DLTM-100-2

7.0 **MAINTENANCE** (Continued)

B. SETTING THE MIXER SYSTEM FLOW

1. On the operator panel, switch “POWER” to on, “MIXER” to on, and set mixer speed to “FAST”, the maximum speed.
2. Increase or decrease flow to maximum rpm as listed, or less if requested by customer. Turn in “C” to decrease, turn out to increase.

40 Gallon Kettle	54 RPM
60 Gallon Kettle	48 RPM
80 Gallon Kettle	43 RPM
100 Gallon Kettle	40 RPM



CAUTION: Do not exceed 54 rpm! Decreasing the flow to less than 10 rpm may over centre the swash plate and will damage the pump!

3. Use jam nut to lock adjusting screw when complete.

SETTING THE BRIDGE ACTUATOR

1. On the operator panel, switch “POWER” to on, “MIXER” to on, and set mixer speed to “STOP”.
2. The pressure reducing valve and associated gauge are located at the back of the hydraulic unit. Adjust it to 800 psi.
3. The speed of the actuator is controlled by an in-line flow control valve also located at the back of the unit. There is also a locking set screw provided on the adjusting knob.
4. Using the “RAISE/LOWER” tilt switch on the operator panel, adjust the flow control so that the stroke is completed at a safe speed.

INSTALLATION AND OPERATION MANUAL, DIRECT STEAM SINGLE & TWIN MIXER
KETTLE, MODELS DLTM-40 TO DLTM-100 AND DLTM-40-2 TO DLTM-100-2

8.0 TROUBLESHOOTING

EXTREMELY SLOW COOKING TIME

If cooking time is abnormally slow, this may be due to insufficient steam pressure and/or volume. Determine that pressure on incoming steam line at kettle is within 5 psi of rated kettle pressure. Note that pressures approaching the rated kettle pressure are liable to set off the safety relief valve. If required pressure is available to kettle, then volume of steam may not be sufficient. Minimum 3/4" pipe size is required to the kettle but if the steam generating source is at a great distance from the kettle, larger pipe will be required. Finally, the core of the steam supply pipe may have debris or scalants that impede steam flow and will require disassembly and inspection.

AIR VENTING

A steam trap assembly is plumbed to the exhaust (condensate) side of the kettle(s). The thermostatic trap is a mechanical device that closes on high temperature and opens when the temperature drops, allowing water which formed from the condensate to exhaust, but retain steam under pressure.

The temperatures required for the cooking process to function adequately must be greater than the boiling point of the liquid food product. The greater the steam pressure used, the higher the temperature and the quicker the cooking process. For example, steam pressurized at 30 psi reaches a temperature of 274 degrees Fahrenheit (135 degrees Celsius). Since air is an unsuitable media through which heat may be transferred, it should be exhausted from the jacket by opening the pressure relief valve until the air has been completely replaced by pressurized steam.

In the initial stages of the cooking process, when the steam comes in contact with the cold kettle bowl surface, it condenses and forms a large amount of water. The condensate water must be removed from the kettle jacket in order for the kettle to function adequately. The ball valve located at the base of the kettle jacket may be opened to remove the water. It may be necessary to repeat this procedure several times depending on the number of batches being cooked as each batch will create condensate. If the kettle appears to be slow in heating, this would indicate that there is water in the jacket. Open ball valve and drain. Close valve and commence operation of kettle.

INSTALLATION AND OPERATION MANUAL, DIRECT STEAM SINGLE & TWIN MIXER
KETTLE, MODELS DLTM-40 TO DLTM-100 AND DLTM-40-2 TO DLTM-100-2

8.0 TROUBLESHOOTING (Continued)

HYDRAULIC SYSTEM

SOLENOID VALVES FAILED TO OPERATE

1. Voltage too low will not complete the stroke of alternating current (AC) and the solenoid will burn out the coil.
2. Signal to both solenoids of a double solenoid valve simultaneously. One or both of the valves will be unable to complete their stroke and burn out. Make certain the electrical signal is interlocked so that this condition cannot exist.
3. Incorrect voltage or frequency will prevent operation or burn out coil.
4. Foreign matter in valve.
5. Oil too hot.

PUMP

1. Excessive noise caused by vacuum leak in suction line.
2. Misalignment of drive mechanism will cause high noise level in operation.
3. Relief set too high.
4. Return line above fluid level.
5. Reversed rotation.
6. Filter breather plugged.
7. Viscosity of oil too high.
8. Loose or worn pump parts.
9. Air leak at pump shaft seal.
10. Oil too low, drawing in air.
11. Air bubbles in intake oil.

INSTALLATION AND OPERATION MANUAL, DIRECT STEAM SINGLE & TWIN MIXER
KETTLE, MODELS DLTM-40 TO DLTM-100 AND DLTM-40-2 TO DLTM-100-2

8.0 TROUBLESHOOTING (Continued)

EXCESSIVE WEAR

1. Abrasive material in oil causing wear.
2. Oil viscosity too low.
3. Pump misalignment.
4. Air being drawn in through inlet of pump.
5. System pressure exceeds pump rating.

BROKEN INTERNAL PARTS

1. Lack of oil.
2. Excessive torquing of housing bolts.
3. Solid matter being drawn in from reservoir.

DIRTY OIL

1. Components not cleaned properly after servicing.
2. Air breather left off.
3. Filter dirty or ruptured.

FOAMING OIL

1. Return line not below oil level.
2. Oil contaminated.
3. Suction leak to pump.

MOISTURE IN OIL

1. Water in oil supply.
2. Extreme temperature differential.

INSTALLATION AND OPERATION MANUAL, DIRECT STEAM SINGLE & TWIN MIXER
KETTLE, MODELS DLTM-40 TO DLTM-100 AND DLTM-40-2 TO DLTM-100-2

8.0 TROUBLESHOOTING (Continued)

OVERHEATING OF SYSTEM

1. Continuous operation at relief setting.
 - a) Stalling under load.
 - b) Viscosity of oil too high.
2. Excessive slippage or internal leakage.
 - a) Fluid too low.
3. System relief valve set too high.
4. Power unit ambient too high.
5. Insufficient volume of cold water supply to oil cooler.

INSTALLATION AND OPERATION MANUAL, DIRECT STEAM SINGLE & TWIN MIXER
KETTLE, MODELS DLTM-40 TO DLTM-100 AND DLTM-40-2 TO DLTM-100-2



SAFETY DATA SHEET

1. Identification

Product name	FM HYDRAULIC OIL 32
Other means of identification	No data available.
Recommended use:	Lubricating fluid
Restrictions on use:	Industrial use only

Manufacturer/Importer/Supplier/Distributor Information

Manufacturer

Company Name: Fuchs Lubricants Co.
Address: 17050 Lathrop Avenue
Harvey, Illinois 60426
Telephone: 708-333-8900
Fax: 708-333-9180

Contact Person: EHS Department
E-mail: sds@fuchsus.com

Emergency telephone number: 708-333-8900 (Bus. hrs) 800-255-3924 (24 hrs)

2. Hazard(s) identification

Hazard Classification

Not classified as hazardous under 29CFR 1910.1200 (HazCom 2012).

Label Elements

Hazard Symbol:	No symbol
Signal Word:	No signal word.
Hazard Statement:	not applicable
Precautionary Statement	not applicable

Other hazards which do not result in GHS classification: None.

3. Composition/information on ingredients

SDS_US

1/8

INSTALLATION AND OPERATION MANUAL, DIRECT STEAM SINGLE & TWIN MIXER
KETTLE, MODELS DLTM-40 TO DLTM-100 AND DLTM-40-2 TO DLTM-100-2



SAFETY DATA SHEET

Hazardous Component(s):

Chemical name	CAS-No.	Concentration
White mineral oil	Confidential	60 - 100 %

Specific chemical identities and/or exact percentages have been withheld as trade secrets.

4. First-aid measures

Ingestion:	Rinse mouth thoroughly. Call a POISON CENTER/doctor/...if you feel unwell. Do NOT induce vomiting.
Inhalation:	Move to fresh air. Call a POISON CENTER/doctor/...if you feel unwell.
Skin Contact:	Remove contaminated/saturated clothing and shoes. Wash contact areas with soap and water. If skin irritation occurs: Get medical advice/attention.
Eye contact:	Flush thoroughly with water. If irritation occurs, get medical assistance. Continue to rinse for at least 15 minutes.

Most important symptoms/effects, acute and delayed

Symptoms: No data available.

Indication of immediate medical attention and special treatment needed

Treatment: Get medical attention as appropriate or if symptoms persist.

5. Fire-fighting measures

General Fire Hazards: No unusual fire or explosion hazards noted.

Suitable (and unsuitable) extinguishing media

Suitable extinguishing media:	Water spray, fog, CO ₂ , dry chemical, or regular foam. Use fire-extinguishing media appropriate for surrounding materials.
Unsuitable extinguishing media:	Do not use water jet as an extinguisher, as this will spread the fire.
Specific hazards arising from the chemical:	Heat may cause the containers to explode. During fire, gases hazardous to health may be formed.

Special protective equipment and precautions for firefighters

Special fire fighting procedures: No data available.

INSTALLATION AND OPERATION MANUAL, DIRECT STEAM SINGLE & TWIN MIXER
KETTLE, MODELS DLTM-40 TO DLTM-100 AND DLTM-40-2 TO DLTM-100-2



SAFETY DATA SHEET

Special protective equipment for fire-fighters: Firefighters must use standard protective equipment including flame retardant coat, helmet with face shield, gloves, rubber boots, and in enclosed spaces, SCBA.

6. Accidental release measures

Personal precautions, protective equipment and emergency procedures: See Section 8 of the SDS for Personal Protective Equipment. Do not touch damaged containers or spilled material unless wearing appropriate protective clothing. Keep unauthorized personnel away. Ensure adequate ventilation.

Methods and material for containment and cleaning up: Absorb with sand or other inert absorbent. Stop the flow of material, if this is without risk.

Environmental Precautions: Avoid release to the environment. Do not contaminate water sources or sewer. Prevent further leakage or spillage if safe to do so.

7. Handling and storage

Precautions for safe handling: Observe good industrial hygiene practices. Wear appropriate personal protective equipment. Do not expose to intense heat as product may expand and pressurize container.

Conditions for safe storage, including any incompatibilities: Store in original tightly closed container. Avoid contact with oxidizing agents. Store away from incompatible materials.

8. Exposure controls/personal protection

Exposure Limits

Chemical name	type	Exposure Limit Values	Source
White mineral oil - Inhalable fraction.	TWA	5 mg/m ³	US. ACGIH Threshold Limit Values (03 2012)
White mineral oil - Mist.	PEL	5 mg/m ³	US. OSHA Table Z-1 Limits for Air Contaminants (29 CFR 1910.1000) (02 2006)

Protective Measures: Use personal protective equipment as required.

Respiratory Protection: In case of inadequate ventilation use suitable respirator. Seek advice from supervisor on the company's respiratory protection standards.

Eye Protection: Wear safety glasses with side shields (or goggles).

Skin and Body Protection: Wear chemical-resistant gloves, footwear, and protective clothing appropriate for the risk of exposure. Contact health and safety professional or manufacturer for specific information.

INSTALLATION AND OPERATION MANUAL, DIRECT STEAM SINGLE & TWIN MIXER
KETTLE, MODELS DLTM-40 TO DLTM-100 AND DLTM-40-2 TO DLTM-100-2



LUBRICANTS.
TECHNOLOGY.
PEOPLE.

SAFETY DATA SHEET

Hygiene measures:

Always observe good personal hygiene measures, such as washing after handling the material and before eating, drinking, and/or smoking. Routinely wash work clothing to remove contaminants. Contaminated work clothing should not be allowed out of the workplace. Discard contaminated footwear that cannot be cleaned. Avoid contact with skin, eyes, and clothing.

9. Physical and chemical properties

Appearance

Physical state:	Liquid
Form:	No data available.
Color:	Water-white
Odor:	Mild
Odor threshold:	No data available.
pH:	No data available.
Melting point/freezing point:	No data available.
Initial boiling point and boiling range:	No data available.
Flash Point:	> 100 °C (212 °F)
Evaporation rate:	No data available.
Flammability (solid, gas):	No data available.
Upper/lower limit on flammability or explosive limits	
Flammability limit - upper (%):	No data available.
Flammability limit - lower (%):	No data available.
Explosive limit - upper (%):	No data available.
Explosive limit - lower (%):	No data available.
Vapor pressure:	No data available.
Vapor density:	No data available.
Relative density:	0.8607
Solubility(ies)	
Solubility in water:	Insoluble
Solubility (other):	No data available.
Partition coefficient (n-octanol/water):	No data available.
Auto-ignition temperature:	No data available.
Decomposition temperature:	No data available.
Viscosity:	32 mm ² /s (40 °C)

10. Stability and reactivity

Reactivity:	Not reactive during normal use.
Chemical Stability:	Material is stable under normal conditions.

INSTALLATION AND OPERATION MANUAL, DIRECT STEAM SINGLE & TWIN MIXER
KETTLE, MODELS DLTM-40 TO DLTM-100 AND DLTM-40-2 TO DLTM-100-2



LUBRICANTS.
TECHNOLOGY.
PEOPLE.

SAFETY DATA SHEET

Possibility of hazardous reactions:	None under normal conditions.
Conditions to avoid:	Avoid heat or contamination.
Incompatible Materials:	No data available.
Hazardous Decomposition Products:	Thermal decomposition or combustion may liberate carbon oxides and other toxic gases or vapors.

11. Toxicological information

Information on likely routes of exposure

Ingestion:	May be ingested by accident. Ingestion may cause irritation and malaise.
Inhalation:	Inhalation is the primary route of exposure. In high concentrations, vapors, fumes or mists may irritate nose, throat and mucus membranes.
Skin Contact:	Prolonged skin contact may cause redness and irritation.
Eye contact:	Eye contact is possible and should be avoided.

Symptoms related to the physical, chemical and toxicological characteristics

Ingestion:	No data available.
Inhalation:	No data available.
Skin Contact:	No data available.
Eye contact:	No data available.

Information on toxicological effects

Acute toxicity (list all possible routes of exposure)

Oral Product:	Not classified for acute toxicity based on available data.
Dermal Product:	ATEmix (): 2000 - 5000 mg/kg
Inhalation Product:	Not classified for acute toxicity based on available data.

Repeated dose toxicity Product:	No data available.
--	--------------------

Skin Corrosion/Irritation Product:	No data available.
---	--------------------

INSTALLATION AND OPERATION MANUAL, DIRECT STEAM SINGLE & TWIN MIXER
KETTLE, MODELS DLTM-40 TO DLTM-100 AND DLTM-40-2 TO DLTM-100-2



LUBRICANTS.
TECHNOLOGY.
PEOPLE.

SAFETY DATA SHEET

Serious Eye Damage/Eye Irritation

Product: No data available.

Respiratory or Skin Sensitization

Product: No data available.

Carcinogenicity

Product: No data available.

IARC Monographs on the Evaluation of Carcinogenic Risks to Humans:

No carcinogenic components identified

US. National Toxicology Program (NTP) Report on Carcinogens:

No carcinogenic components identified

US. OSHA Specifically Regulated Substances (29 CFR 1910.1001-1050):

No carcinogenic components identified

Germ Cell Mutagenicity

In vitro

Product: No data available.

In vivo

Product: No data available.

Reproductive toxicity

Product: No data available.

Specific Target Organ Toxicity - Single Exposure

Product: No data available.

Specific Target Organ Toxicity - Repeated Exposure

Product: No data available.

Aspiration Hazard

Product: No data available.

Other effects:

No data available.

12. Ecological information

General information:

This product has not been evaluated for ecological toxicity or other environmental effects.

13. Disposal considerations

INSTALLATION AND OPERATION MANUAL, DIRECT STEAM SINGLE & TWIN MIXER
KETTLE, MODELS DLTM-40 TO DLTM-100 AND DLTM-40-2 TO DLTM-100-2



SAFETY DATA SHEET

Disposal instructions: Discharge, treatment, or disposal may be subject to national, state, or local laws. Dispose of waste at an appropriate treatment and disposal facility in accordance with applicable laws and regulations, and product characteristics at time of disposal. It is the responsibility of the product user or owner to determine at the time of disposal, which waste regulations must be applied.

Contaminated Packaging: Empty containers should be taken to an approved waste handling site for recycling or disposal.

14. Transport information

DOT
Not regulated.

IMDG
Not regulated.

IATA
Not regulated.

15. Regulatory information

US Federal Regulations

US. OSHA Specifically Regulated Substances (29 CFR 1910.1001-1050)
None present or none present in regulated quantities.

Superfund Amendments and Reauthorization Act of 1986 (SARA)

Hazard categories
None

SARA 313 (TRI Reporting)
None present or none present in regulated quantities.

US State Regulations

US. California Proposition 65
No component is regulated by CA Prop 65.

16. Other information, including date of preparation or last revision

Issue Date: 24.06.2016
Revision Date: 24.06.2016
Version #: 1.0

SDS_US

7/8

INSTALLATION AND OPERATION MANUAL, DIRECT STEAM SINGLE & TWIN MIXER
KETTLE, MODELS DLTM-40 TO DLTM-100 AND DLTM-40-2 TO DLTM-100-2



SAFETY DATA SHEET

Further Information: No data available.

Disclaimer: This information is provided without warranty. The information is believed to be correct. This information should be used to make an independent determination of the methods to safeguard workers and the environment.