



**IMPORTANT FOR FUTURE REFERENCE**

Please complete this information and retain this manual for the life of the equipment:

Model #: \_\_\_\_\_

Serial #: \_\_\_\_\_

Date Purchased: \_\_\_\_\_

## INSTALLATION & OPERATION MANUAL

**9LTM-40-(2) 9LTM-60-(2) 9LTM-80-(2) 9LTM-100-(2)**  
**Single and Twin Mixer Kettles**

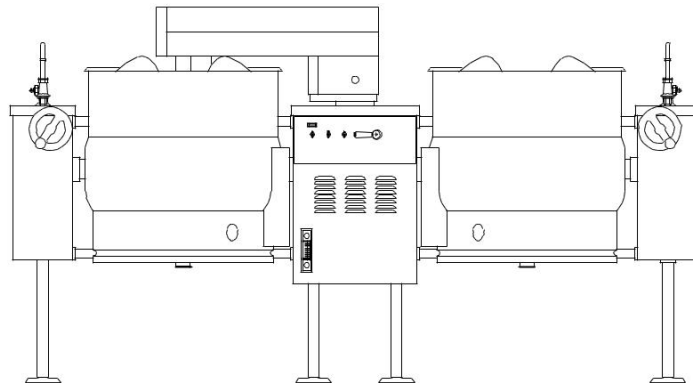
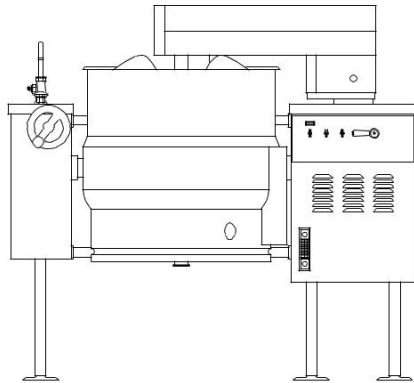

**⚠ WARNING**

Improper installation, adjustment, alteration, service or maintenance can cause property damage, injury or death. Read the installation, operating and maintenance instructions thoroughly before installing or servicing this equipment.

**CROWN FOOD SERVICE EQUIPMENT**

 A Middleby Company

70 Oakdale Road, Downsview (Toronto) Ontario, Canada, M3N 1V9

Telephone: 919-762-1000 [www.crownsteamgroup.com](http://www.crownsteamgroup.com)

Printed in Canada



**IMPORTANT NOTES FOR INSTALLATION AND OPERATION**



**This is the safety alert symbol. It is used to alert you to potential personal injury hazards. Obey all safety messages that follow this symbol to avoid possible injury or death.**



**WARNING: Improper installation, operation, adjustment, alteration, service or maintenance can cause property damage, injury or death. Read the installation, operating and maintenance instructions thoroughly before installing, operating or servicing this equipment.**

**Adequate clearances must be maintained for safe and proper operation.**

**Intended for commercial use only. Not for household use.**

**This manual should be retained for future reference.**





INSTALLATION AND OPERATION MANUAL, ELECTRIC SELF GENERATING SINGLE AND  
TWIN STEAM MIXER KETTLE, MODELS ELTM-40 TO 100 AND ELTM 40-2 TO 100-2

**TABLE OF CONTENTS**

<b>DESCRIPTION</b>	<b>PAGE</b>
Important Notes for Installation and Operation . . . . .	2
1.0 Service Connections . . . . .	4
2.0 Introduction . . . . .	6
3.0 Installation Instructions . . . . .	9
4.0 Operation Instructions . . . . .	11
5.0 Cleaning Instructions . . . . .	15
6.0 Maintenance . . . . .	19
7.0 Troubleshooting . . . . .	23
Appendix A, Safety Data Sheet - Kettle . . . . .	30
Appendix B, Safety Data Sheet - Hydraulic Unit . . . . .	40

# INSTALLATION AND OPERATION MANUAL, ELECTRIC SELF GENERATING SINGLE AND TWIN STEAM MIXER KETTLE, MODELS ELTM-40 TO 100 AND ELTM 40-2 TO 100-2

## 1.0 SERVICE CONNECTIONS

-  — COLD WATER : 3/8" Nominal tubing to kettle fill faucet (OPTIONAL)
-  — ELECTRICAL CONNECTION: to be as specified on data plate.
-  — OIL COOLER WATER IN : 3/8" Tube bulkhead Union.
-  — OIL COOLER WATER OUT : 3/8" Tube bulkhead Union.

### ELECTRICAL CHARACTERISTICS

Available kW			AMPS PER LINE								
MODEL	STD.	OPT.	KW	PHASE	208V	220V	240V	380V	415V	480V	600V
ELTM-40	24	N/A	24	3	81	77	71	45	41	36	28
ELTM-60	24	33	33	3	106	101	92	59	54	47	37
ELTM-80	24	33									
ELTM-100	24	33									

### DIMENSIONS



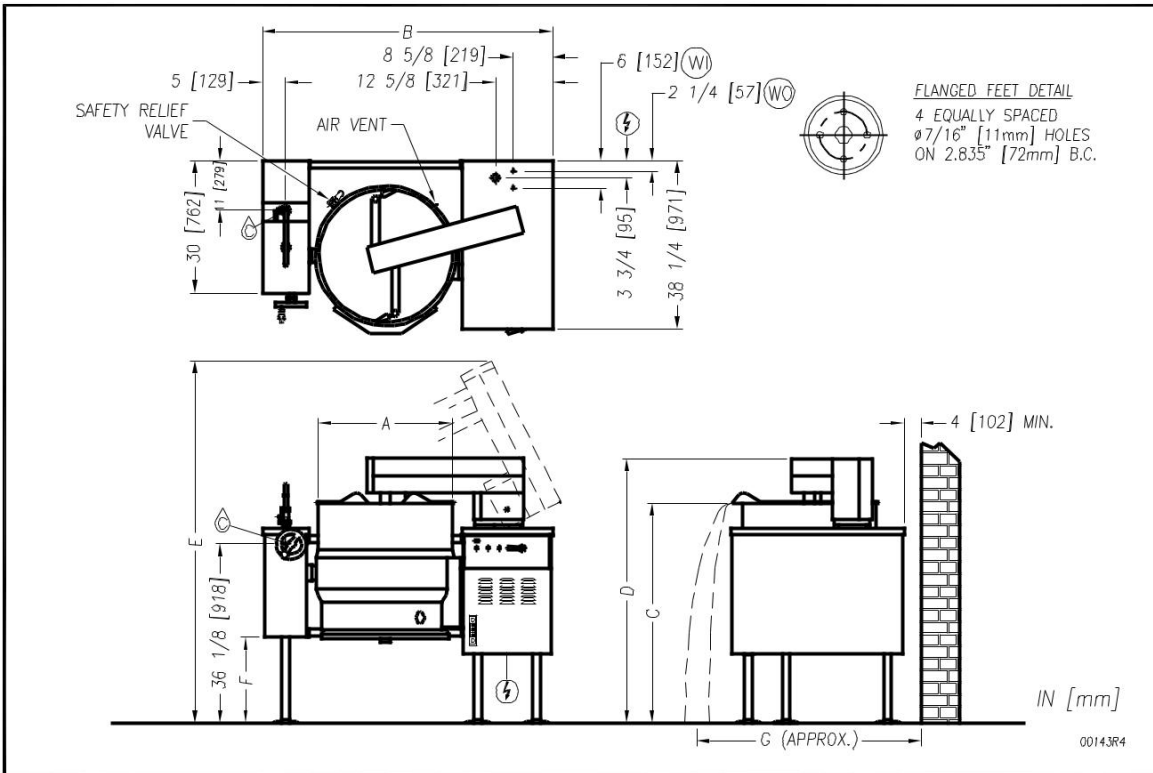

MODEL	CAPACITY		A	B	C	D	E	F	G
ELTM-40	40 gallons	inches	26	62.25	43.25	55	75.625	15.125	56
	152 litres	mm	660	1581	1099	1397	1921	384	1422
ELTM-60	60 gallons	inches	29.5	66	49	58.5	80	19.5	58
	227 litres	mm	749	1676	1245	1486	2032	495	1473
ELTM-80	80 gallons	inches	33	69.25	49	58.5	80	19.5	60
	303 litres	mm	838	1759	1245	1486	2032	495	1524
ELTM-100	100 gallons	inches	35.5	71.5	49	58.5	85	19.5	63
	379 litres	mm	902	1816	1245	1486	2159	495	1600



As continued product improvement is a policy of Crown, specifications are subject to change without notice.

# INSTALLATION AND OPERATION MANUAL, ELECTRIC SELF GENERATING SINGLE AND TWIN STEAM MIXER KETTLE, MODELS ELTM-40 TO 100 AND ELTM 40-2 TO 100-2

## 1.0 SERVICE CONNECTIONS (Continued)

	— COLD WATER — 3/8" Nominal tubing to kettle fill faucet (OPTIONAL)
	— ELECTRICAL CONNECTION: to be as specified on data plate. Two connections required.
	— OIL COOLER WATER IN : 3/8" Tube bulkhead Union.
	— OIL COOLER WATER OUT : 3/8" Tube bulkhead Union.

### ELECTRICAL CHARACTERISTICS

Available kW/Kettle			AMPS PER LINE (Supply #1/Supply #2)								
MODEL	STD.	OPT.	KW	PHASE	208V	220V	240V	380V	415V	480V	600V
ELTM-40-2	24	N/A	24	3	81/67	77/63	71/58	45/37	41/34	36/29	29/23
ELTM-60-2	24	33	33	3	106/92	101/87	92/80	59/51	54/46	47/40	37/32
ELTM-80-2	24	33									
ELTM-100-2	24	33									

### DIMENSIONS

MODEL	CAPACITY		A	B	C	D	E	F	G
ELTM-40-2	40 gallons	inches	26	104.5	43.25	55	75.625	15.125	56
	152 litres	mm	660	2654	1099	1397	1921	384	1422
ELTM-60-2	60 gallons	inches	29.5	112	49	58.5	80	19.5	58
	227 litres	mm	749	2845	1245	1486	2032	495	1473
ELTM-80-2	80 gallons	inches	33	118.5	49	58.5	80	19.5	60
	303 litres	mm	838	3010	1245	1486	2032	495	1524
ELTM-100-2	100 gallons	inches	35.5	123	49	58.5	85	19.5	63
	379 litres	mm	902	3124	1245	1486	2159	495	1600

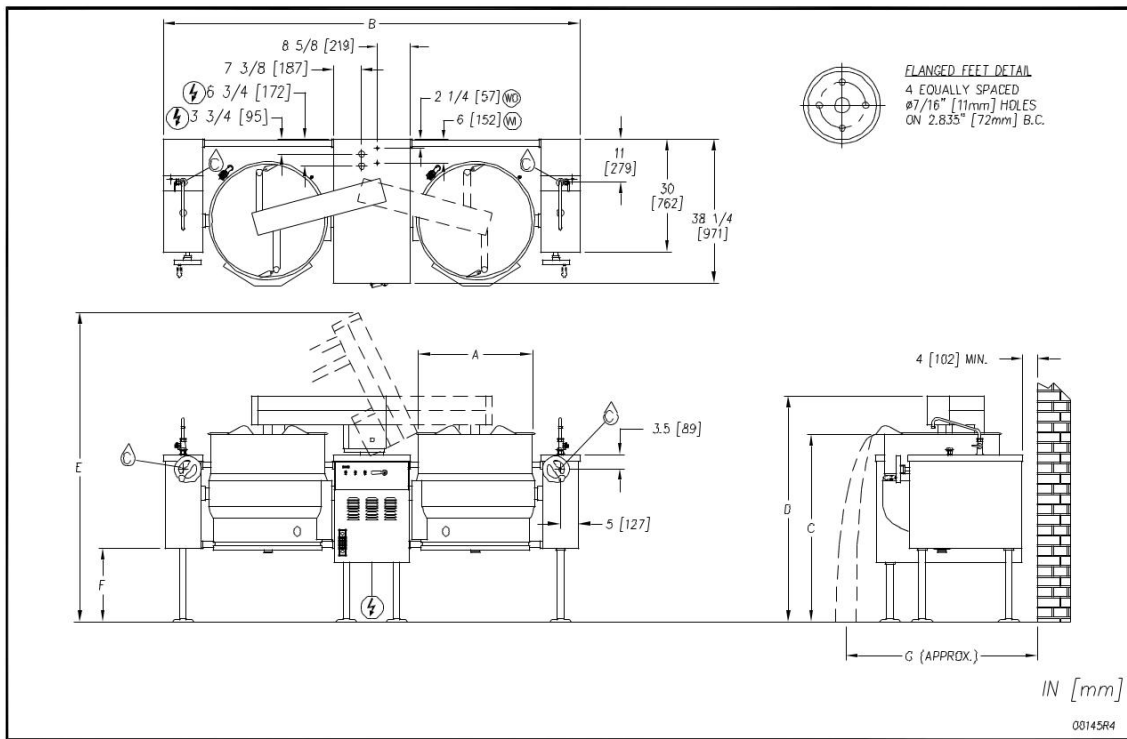

As continued improvement is a policy of Crown, specifications are subject to change without notice.

# INSTALLATION AND OPERATION MANUAL, ELECTRIC SELF GENERATING SINGLE AND TWIN STEAM MIXER KETTLE, MODELS ELTM-40 TO 100 AND ELTM 40-2 TO 100-2

## **2.0 INTRODUCTION**

### **DESCRIPTION**

All electrically powered kettles described and referred to in this manual are pressure vessels of a double-wall construction forming a sealed jacket (chamber) enveloping the lower two thirds of the kettle bowl surface.

The kettle bowl is the container for the food product which ideally should be a liquid or semi-liquid consistency to achieve complete contact with the bowl surface. Food products will fully absorb the heat transmitted through that surface from the pressurized steam generated in the kettle jacket.

The jacket is intended to function as a self contained sealed chamber with a permanent solution of water and antifreeze sufficient not only to immerse and thereby protect replaceable electric heating elements, but also provide the steam source during the steam generating process.

The heating elements are thermostatically controlled to provide precise temperatures throughout the range from slow simmer to rolling boil.

All tilting kettles are intended to be permanently floor mounted on legs with adjustable flanged feet.

A sealed stainless steel tilt mechanism permits the kettle to tilt forward a full 90E for complete emptying. The tilting mechanism is self locking for positive stop action.

### **MIXER FEATURES**

The mixer is a variable speed unit powered by a 5 hp electric motor driving a hydraulic pump. Two heavy duty hydraulic motors drive the primary scraper/agitator and secondary high speed mixer. Both are removable without tools for cleaning. They are housed in a stainless steel bridge that is power tilted and swings 140E out of the way for tilting the kettle(s).

### **CAPACITIES**

All models are suffixed with either -40, -60, -80 or -100 to indicate the capacity of that kettle in US gallons. Models with the suffix -2 indicate a twin model. Thus a unit with suffix -40-2 has two 40 gallon kettles, one on each side of the mixer console. An ELTM-40 indicates a single 40 gallon kettle two thirds jacketed electrically powered steam kettle.

# INSTALLATION AND OPERATION MANUAL, ELECTRIC SELF GENERATING SINGLE AND TWIN STEAM MIXER KETTLE, MODELS ELTM-40 TO 100 AND ELTM 40-2 TO 100-2

## **2.0 INTRODUCTION** (Continued)

### **FUNCTIONING MODE**

All electrically powered self steam generating kettles consist of a jacket containing a permanent solution of water and antifreeze sufficient to completely immerse and protect replaceable electric heating elements.

To minimize tampering, the Safety Valve is plumbed toward the rear of the kettle jacket. Should any component malfunction and cause the pressure in the jacket to reach the rated pressure of the kettle, this protective device will open automatically and release excessive pressurized steam.

When the Power Switch is turned ON and the Temperature Control (Thermostat) Knob dialed, the TEMPERATURE pilot light will ignite and contactors will close to allow power to the elements. Steam generation will commence and continue until the preselected temperature is reached, at which point the contactors open, cutting off power to heating the elements. The TEMPERATURE pilot light will then extinguish. When the temperature of the water in the jacket drops slightly, the cycle will repeat itself thus making it possible to maintain any selected precise cooking mode temperature.

The temperature required for the cooking process to function adequately must be greater than the boiling point of the liquid food product. Further, the higher the temperature, the greater the steam pressure attained in the jacket and consequently the quicker the cooking process. For example, steam pressurized at 30 p.s.i. attains a temperature of 274° Fahrenheit.

Since air is an unsuitable media through which heat may be transferred, it has been removed from the kettle jacket during testing at the factory. The Pressure Gauge should indicate vacuum in the jacket in green zone on the gauge (approximately 20 - 25 inches Hg) when the kettle is cold or has been inoperative for some time. The kettle jacket is intended to function at all times as a completely sealed self-contained chamber and it is especially advisable not to trip the safety relief valve during inoperative periods since this will break the vacuum seal and allow air to enter the kettle jacket.

The Temperature Controls (thermostats) used in these kettles have been calibrated to prevent the heating elements from generating steam pressure that would exceed the rated working pressure of the kettle. In the unlikely event that the Temperature Control fails and the heating elements remain energized, the Safety Valve will blow and release the excessive pressure and steam from the jacket, consequently lowering the water level in the jacket. The Safety Probe sensing depletion of the water level in the kettle jacket will not only activate the LOW WATER level indicator pilot light, but also signal the Liquid Level Control to switch off power and de-energize the circuit to the heating elements (preventing element burn outs) until the water level is adequately replenished.

INSTALLATION AND OPERATION MANUAL, ELECTRIC SELF GENERATING SINGLE AND  
TWIN STEAM MIXER KETTLE, MODELS ELTM-40 TO 100 AND ELTM 40-2 TO 100-2

**2.0 INTRODUCTION** (Continued)

**FUNCTIONING MODE** (Continued)

The mixer is a variable speed unit powered by a 5 hp electric motor driving a hydraulic pump. Two heavy duty hydraulic motors drive the primary scraper/agitator and secondary high speed mixer. Both are removable without tools for cleaning. They are housed in a stainless steel bridge that is power tilt and swings 140E out of the way for tilting the kettles(s). Once the bridge has been lifted the agitators cannot be operated as a safety switch is activated. Bridge may now be moved out of the way or if a twin mixer, moved to the other kettle. The speed control is located on the front panel and may be set to the desired speed by turning. The maximum speed will not exceed 54 RPM on the smallest kettle and 40 RPM on the largest.

# INSTALLATION AND OPERATION MANUAL, ELECTRIC SELF GENERATING SINGLE AND TWIN STEAM MIXER KETTLE, MODELS ELTM-40 TO 100 AND ELTM 40-2 TO 100-2

## **3.0 INSTALLATION INSTRUCTIONS**

### **UNPACKING**

Immediately after unpacking, check for possible shipping damage. If the kettle is found to be damaged, save the packaging material and contact the carrier within 15 days of delivery.

### **INSTALLATION**

Before installing, verify that the electrical service agrees with the specifications on the rating plate located on the right side of the tilt console. If the supply and equipment requirements do not agree, contact your dealer or Crown Food Service Equipment Ltd.

The kettle must be installed in accordance with State and/or local codes. In the USA, the National Electrical Code, ANSI/NFPA-70 (latest edition). In Canada, the Canadian Electrical Code, Part 1, CSA Standard C22.1 (latest edition).

1. Select a location to provide drainage for kettle pour path when tilted and for butterfly valve if so equipped. Allow sufficient rear clearance from wall for access to rear service panel on hydraulic console.
2. Level unit. With kettle in the upright position, place a carpenter's level on top of the kettle and turn the adjustable feet to level kettle side-to-side and front to back. Mark hole locations on floor through anchoring holes provided in flanged adjustable feet.
3. Remove unit and drill holes where marked and insert expansion shields to accommodate 5/16" size lag bolts.
4. Reposition unit. Re-level kettle by making necessary adjustments on flanged feet.
5. Bolt down unit and seal with Silastic or equivalent sealing compound. Sealant must be applied not only to bolt heads but also around flanges making contact with the floor surface to fulfil NSF requirements. Wipe off excess sealant immediately.
6. Connect water drain line from cooling system to drain or return line.
7. Connect cold water supply line for cooling system as indicated in bottom of hydraulic console.
8. The relief valve on the kettles(s) must not be adjusted or closed off as they are set to relieve excess pressure in the kettle(s).
9. Do not make any adjustments to the hydraulic system as it has been set at the factory.

# INSTALLATION AND OPERATION MANUAL, ELECTRIC SELF GENERATING SINGLE AND TWIN STEAM MIXER KETTLE, MODELS ELTM-40 TO 100 AND ELTM 40-2 TO 100-2

## **3.0 INSTALLATION INSTRUCTIONS** (Continued)

### **ELECTRICAL CONNECTIONS**

A control box with a power supply equivalent to the electrical rating of the unit should be located nearby. A waterproof electrical connection for the power supply to the unit must be provided.

Remove the back panel of the hydraulic console and make electrical connection per wiring diagram located inside the console in plastic bag attached to tank. A waterproof electrical connection from power supply to rear of hydraulic console must be provided.

Ground kettle to terminal provided in the hydraulic console.

Once proper connections are made, replace the back panel on hydraulic console, turn power ON and check for proper operation.

### **SERVICE CONNECTIONS**

All internal wiring for the kettle and hydraulic power unit is complete.

Connect water supply for cooling system as shown in Service Connections.

If faucet is provided connect water supply and check for proper operation.

### **INSTALLATION CODES AND STANDARDS**

Your electric mixing kettle must be installed in accordance with:

1. Provincial and local codes, or in the absence of local codes, with C.S.A. C22.1 Canadian Electrical Code, Part 1, or in the U.S.A., the National Electrical Code ANSI/NFPA-70 (latest edition).
2. ANSI NFPA Standard #96 "Vapour Removal from Cooking Equipment", (latest edition), available from the National Fire Protection Association, Batterymarch Park, Quincy, MA, 02269.

#### 4.0 OPERATION INSTRUCTIONS



**WARNING: The kettle and its parts are hot. Use care when operating, cleaning and servicing the kettle.**

#### KETTLE

Ensure that the external electrical service to kettle is on.

Check pressure gauge for correct cold kettle reading. Reading should be in the green area of the gauge indicating 25 - 30 In. Hg (630 - 730 mm Hg) of vacuum. If reading is not low enough, follow VENTING procedure in Troubleshooting section prior to using kettle.

Place power switch to ON position.

Preheat kettle by placing thermostat knob at '10' and wait until TEMPERATURE light goes off.

**NOTE: Preheating should not be used when cooking milk and egg food products which adhere to hot cooking surfaces. These foods should be placed into kettle before heating has begun.**

Add food to be cooked into kettle.

Place thermostat knob at required temperature setting from 1 to 10 coinciding with the following table:

INSTALLATION AND OPERATION MANUAL, ELECTRIC SELF GENERATING SINGLE AND TWIN STEAM MIXER KETTLE, MODELS ELTM-40 TO 100 AND ELTM 40-2 TO 100-2

**4.0 OPERATION INSTRUCTIONS** (Continued)

<b>THERMOSTAT SETTING</b>	<b>APPROXIMATE (JACKET) TEMPERATURE</b>	
1	90° Fahrenheit	30° Celsius
2	118° Fahrenheit	42° Celsius
3	138° Fahrenheit	54° Celsius
4	158° Fahrenheit	64° Celsius
5	178° Fahrenheit	76° Celsius
6	200° Fahrenheit	88° Celsius
7	220° Fahrenheit	100° Celsius
8	240° Fahrenheit	111° Celsius
9	260° Fahrenheit	122° Celsius
10	280° Fahrenheit	134° Celsius

When cooking is finished set thermostat knob and power switch to OFF position.

Pour finished product from kettle using tilt handle. Be careful to avoid splashing.

Add water to kettle for cleaning purposes.

Wash kettle thoroughly. See CLEANING procedure, next section.

#### 4.0 OPERATION INSTRUCTIONS (Continued)

##### OPERATION OF MIXER UNIT

Power to operate the mixer unit is controlled by the “Main Power” switch located on the left side of the control panel. Ensure that mixer “speed” control is set to the “stop” position. Place switch in the “ON” position. Set the mixer switch, located beside the main power switch, to “ON” position. Note that the agitators should not be turning. The speed control has four basic settings which are: stop, slow, medium and fast. Set the speed control to the slow position and observe that the agitators begin to turn.



**CAUTION: Never place hands inside kettle when agitators are in motion.**

Increasing the speed setting on the control will increase the speed at which the agitators turn.

**NOTE: Always start agitators at the slow speed and then gradually increase to the desired speed to avoid splashing or “throwing” the product over edge of kettle.**

##### TO RAISE MIXER BRIDGE

To tilt kettle for emptying or to clean agitators, the mixer bridge will tilt hydraulically upward and manually swing clear of the kettle. To do this, first turn speed control to “STOP” and then turn mixer switch to “OFF”.



**NOTE: Mixer agitator arms must be stopped at 90 degrees to the mixer bridge before raising the bridge. If the agitator arms do not stop in this position when speed selector is set to stop, then “jog” the selector on and off to achieve this position.**

Push the “TILT” switch to the “RAISE” position and hold. Bridge will raise to maximum height. Bridge will stop at any position if the tilt switch is released and will remain in that position until switch is pushed to either raise or lower. When the bridge is fully raised it can be manually turned to the side to be clear of the kettle.

#### 4.0 OPERATION INSTRUCTIONS (Continued)

**NOTE: The bridge is equipped with a safety switch which prevents turning of the agitators, regardless of the mixer switch, or speed control settings. Agitators will not engage unless the bridge is lowered so that the guide pin rests fully in the guide pin bracket on the side of the kettle.**

#### OPERATION OF MIXER UNIT

##### REMOVAL OF AGITATORS

For ease of cleaning, the agitators are removable without tools. To remove, raise bridge as described above and swing clear of kettle. Grasp shaft of large agitator, push up and turn to disengage lock pin. Pull straight down on agitator. Remove the small agitator in the same manner. Soak and wash agitators in warm, soapy water. Never use abrasive cleansers or scouring pads on the stainless steel surfaces as this will damage the finish of the stainless steel.

If it is necessary to remove the scraper blades from the large agitator for cleaning purposes, do so by removing the pin at the end of the mounting shaft and then slide the scraper blades off of the shaft.

To clean the exterior stainless steel panels of your unit, use a damp soft cloth or soft cloth and stainless steel cleaner. Never use abrasive cleansers or scouring pads on the stainless steel surfaces as this will damage the finish of the stainless steel.

## 5.0 CLEANING INSTRUCTIONS



**WARNING: Disconnect the power supply to the appliance before cleaning or servicing.**



**WARNING: Never spray water into electric controls or components!**



**CAUTION: The appliance and its parts are hot. Use care when operating, cleaning and servicing.**



**CAUTION: Do not use cleaning agents that are corrosive.**

Your kettle should be cleaned immediately after each use or when cooking a different product. Before cleaning, check that the kettle has cooled enough to touch it.

1. Ensure that power supply is OFF.
2. Pre-rinse inside of kettle thoroughly and drain to remove any food particles.
3. Using a nylon brush, clean kettle with a mild detergent and warm water rinse. Never use steel wool or scouring powder as it will scratch stainless steel.
4. Tilt kettle fully or open the tangent draw-off valve if one is provided to allow soap and water solution to drain. Rinse with clean water.
5. Wipe the exterior of kettle with a clean, damp cloth.



**WARNING: If you are cleaning a valve that is assembled to a kettle, be sure the kettle is completely empty of any product.**

# INSTALLATION AND OPERATION MANUAL, ELECTRIC SELF GENERATING SINGLE AND TWIN STEAM MIXER KETTLE, MODELS ELTM-40 TO 100 AND ELTM 40-2 TO 100-2

## 5.0 **CLEANING INSTRUCTIONS** (Continued)

Use of cleaning agents that contain chloride, acids or salts are corrosive and may cause pitting and corrosion when used over a period of time; this will reduce the life of the appliance.

Should pitting or corrosion occur, this is not covered by warranty.

Follow the recommended cleaning instructions. Use a mild detergent, warm water and rinse thoroughly.

### **BUTTERFLY VALVE**



**WARNING: If you are cleaning a valve that is assembled to a kettle, be sure the kettle is completely empty of any product.**

### **DISASSEMBLY AND MAINTENANCE**

In the event that repairs or replacement becomes necessary, the following procedures are suggested.

1. Drain and flush the piping surrounding the valve.
2. To remove handle, remove the socket head screw found on top of the valve handle with proper size Allen wrench.
3. Remove the nut and cap screws.
4. Separate the valve body halves.
5. Set the butterfly disc to the open position.
6. Squeeze the seal until oval shaped, then slide the short end of the stem from the seal.
7. Pinch the disc between the thumb and forefinger and pull the long end of the stem.
8. Check for and replace a cracked or worn seal, bushing, stem and disc, or screws.
9. Reassembly is opposite of disassembly.

## 5.0 CLEANING INSTRUCTIONS (Continued)

### WHAT TO DO IF SURFACE RUST APPEARS

Metal utensils should never be used as they will scratch the surface of the equipment and rust may begin to form. To remove surface accumulation of rust from the inadvertent use of such utensils, the following procedure may be used.



**CAUTION: Improper use of this procedure may damage your appliance!**

1. Use undiluted white vinegar with a non-abrasive scouring pad (plastic) or cloth on the affected area to remove the rust stain. The appliance should not be heated and remain at room temperature during the entire cleaning process.
2. If the stain resists removal, additional exposure time with vinegar may be required, to a maximum of one hour.
3. Thoroughly wash all of the vinegar away with fresh clear water. Dry the surface completely and allow one hour before using the appliance to cook.

Following daily and period maintenance procedures will prolong the life of your equipment. Climatic conditions - salt air - may require more thorough and frequent cleaning or the life of the equipment could be adversely affected.

### STAINLESS STEEL

To remove normal dirt, grease or product residue from stainless steel, use ordinary soap and water (with or without detergent) applied with a sponge or cloth. Dry thoroughly with a clean cloth. Never use vinegar or any other corrosive cleaner.

To remove grease and food splatters or condensed vapours that have baked on the equipment, apply cleanser to a damp cloth or sponge and rub cleanser on the metal in the direction of the polishing lines. Rubbing cleanser as gently as possible in the direction of the polished lines will not mar the finish of the stainless steel. **NEVER RUB WITH A CIRCULAR MOTION.**

Soil and burn deposits which do not respond to the above procedure can usually be removed by rubbing the surface with **SCOTCH-BRITE™** scouring pads or **STAINLESS** scouring pads. **DO NOT USE ORDINARY STEEL WOOL** as any particles left on the surface will rust and further spoil the appearance of the finish. **NEVER USE A WIRE BRUSH, STEEL SCOURING PADS (EXCEPT STAINLESS), SCRAPER, FILE OR OTHER STEEL TOOLS.** Surfaces which are marred collect dirt more rapidly and become more difficult to clean. Marring also increases the possibility of corrosive attack. Refinishing may then be required.

## **5.0 CLEANING INSTRUCTIONS** (Continued)

**TO REMOVE HEAT TINT:** Darkened areas sometimes appear on stainless steel surfaces where the area has been subjected to excessive heat. These darkened areas are caused by thickening of the protective surface of the stainless steel and is not harmful. Heat tint can normally be removed by the foregoing, but tint which does not respond to this procedure calls for a vigorous scouring in the direction of the polish lines using **SCOTCH-BRITE™** scouring pads or a **STAINLESS** scouring pad in combination with a powdered cleanser. Heat tint action may be lessened by not applying or by reducing heat to equipment during slack periods.



All food contact surfaces must be thoroughly drained and flushed prior to cooking in the kettle.

**CONTROL PANEL:** The textured control panel should be cleaned with warm water and mild soap. Never use an abrasive cloth or steel wool. Never use cleaning solvents with a hydrocarbon base.

## 6.0 MAINTENANCE

### KETTLE

#### SAFETY VALVE MAINTENANCE AND TESTING

	<p><b>CAUTION!</b> Under normal operating conditions a “try lever test” should be performed every two months. Under severe service conditions, or if corrosion and/or deposits are noticed within the valve body, testing must be performed more often. A “try lever test” should also be performed at the end of any non-service period.</p>
	<p><b>CAUTION!</b> Hot, high pressure fluid may be discharged from body drain and vent during “try lever” test. Care must be taken to avoid any bodily contact.</p>
	<p><b>CAUTION!</b> High sound levels may be experienced during “try lever” test. Wear proper safety equipment and exercise extreme care! Test at, or near, half of the operating pressure by holding the test lever fully open for at least two seconds to flush the valve seat free of sediment and debris. Then release lever and permit the valve to snap shut.</p> <p><b>If lift lever does not activate, or there is no evidence of discharge, turn off equipment immediately and contact a licensed contractor or qualified service personnel.</b></p>

Trunnion block bearings, fitted with a grease nipple should be filled with grease every couple of months or more frequently if so required. They are located in each console box and support the kettle for ease of tilting. The segment gear and worm should be greased at the same time if required. These are located in the tilt console box. No other general maintenance is required other than adhering to the Cleaning Procedure instructions.

INSTALLATION AND OPERATION MANUAL, ELECTRIC SELF GENERATING SINGLE AND  
TWIN STEAM MIXER KETTLE, MODELS ELTM-40 TO 100 AND ELTM 40-2 TO 100-2

**6.0 MAINTENANCE** (Continued)

**HYDRAULIC SYSTEM**

Use "Purity FG AW32" or equivalent oil > Fluid level - 13.62 U.S. gallons.

**SERVICE**

Set up regular schedule for checking the oil temperature, hydraulic hoses and keeping the equipment clean. A thick layer of dirt acts as an insulation and prevents the hydraulic system from cooling.

The hydraulic system has been adjusted and tested at the factory and no adjustment should be needed. If the unit fails to operate properly, all service work must be performed by a qualified service agent.

A thermostat controlled cooling system has been installed in the hydraulic system to maintain oil temperatures while in operation. The oil is cooled by cold water flowing through a heat exchanger alongside of the oil. A thermostat activates at 140E Fahrenheit oil temperature opening the valve and releasing cold water into the heat exchanger, cooling the oil.

**NOTE: At least twice a year have an authorized service person clean and service the unit for maximum performance.**

INSTALLATION AND OPERATION MANUAL, ELECTRIC SELF GENERATING SINGLE AND TWIN STEAM MIXER KETTLE, MODELS ELTM-40 TO 100 AND ELTM 40-2 TO 100-2

6.0 **MAINTENANCE** (Continued)

**SETTING UP HYDRAULIC SYSTEM FOR MIXING KETTLES**

**A. SETTING MIXER SYSTEM PRESSURE**

1. On the operator panel, switch "POWER" to on, "MIXER" to on, and set mixer speed to "STOP".
2. Turn trim relief stem, item "B", completely in.
3. Increase the pump pressure by turning "A" inwards, until gauge "D" reads 1700 psi. The pressure must be 300 psi higher than the pump setting.
4. Adjust trim relief "B" outwards until pressure indicated on gauge "D" begins to drop.
5. Lock the trim relief "B".
6. Decrease the pump pressure by turning "A" outwards, until gauge "D" reads 1400 psi and lock in place.

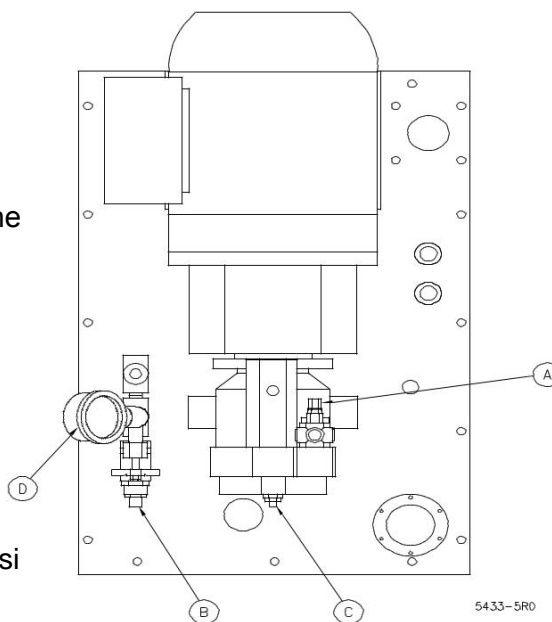

**Figure 2**

## 6.0 MAINTENANCE (Continued)

### B. SETTING THE MIXER SYSTEM FLOW

1. On the operator panel, switch “POWER” to on, “MIXER” to on, and set mixer speed to “FAST”, the maximum speed.
2. Increase or decrease flow to maximum rpm as listed, or less if requested by customer. Turn in “C” to decrease, turn out to increase.

40 gallon kettle	54 RPM
60 gallon kettle	48 RPM
80 gallon kettle	43 RPM
100 gallon kettle	40 RPM



**CAUTION: Do not exceed 54 rpm! Decreasing the flow to less than 10 rpm may over centre the swash plate and will damage the pump!**

3. Use jam nut to lock adjusting screw when complete.

### C. SETTING THE BRIDGE ACTUATOR

1. On the operator panel, switch “POWER” to on, “MIXER” to on, and set mixer speed to “STOP”.
2. The pressure reducing valve and associated gauge are located at the back of the hydraulic unit. Adjust it to 800 psi.
3. The speed of the actuator is controlled by an in-line flow control valve also located at the back of the unit. There is also a locking set screw provided on the adjusting knob.
4. Using the “RAISE/LOWER” tilt switch on the operator panel, adjust the flow control so that the stroke is completed at a safe speed.

6.0 **MAINTENANCE** (Continued)

**SAFETY VALVE MAINTENANCE AND TESTING**

	<p><b>CAUTION!</b> Under normal operating conditions a “try lever test” should be performed every two months. Under severe service conditions, or if corrosion and/or deposits are noticed within the valve body, testing must be performed more often. A “try lever test” should also be performed at the end of any non-service period.</p>
---	---

	<p><b>CAUTION!</b> Hot, high pressure fluid may be discharged from body drain and vent during “try lever” test. Care must be taken to avoid any bodily contact.</p>
---	---

	<p><b>CAUTION!</b> High sound levels may be experienced during “try lever” test. Wear proper safety equipment and exercise extreme care! Test at, or near, half of the operating pressure by holding the test lever fully open for at least two seconds to flush the valve seat free of sediment and debris. Then release lever and permit the valve to snap shut.</p> <p>If lift lever does not activate, or there is no evidence of discharge, turn off equipment immediately and contact a licensed contractor or qualified service personnel.</p>
---	---

INSTALLATION AND OPERATION MANUAL, ELECTRIC SELF GENERATING SINGLE AND TWIN STEAM MIXER KETTLE, MODELS ELTM-40 TO 100 AND ELTM 40-2 TO 100-2

**7.0 TROUBLESHOOTING**

**KETTLE**

**LOW WATER LEVEL**

Proper water level must be maintained within the jacket for the kettle to operate. Depletion of water may occur from excessive opening of or leakage through the safety relief valve.

If water is below required operating level, either initially at start-up or during use, the kettle will automatically shut off and the LOW WATER signal light will come on.

In order for the kettle to operate, the following procedure must be followed:

The kettle must be cool before proceeding with the following steps.

Trip the safety relief valve lever to relieve all pressure from the kettle jacket.

At exterior rear of kettle jacket remove nut from Air Vent.

Insert funnel into Air Vent opening and slowly add the indicated amount of clean water for:

MODEL	PER KETTLE		PER KETTLE	
	ADD:		IF COMPLETELY EMPTY, ADD:	
ELTM-40 (-2)	220 ounces	6.50 litres	548 ounces	16.20 litres
ELTM-60 (-2)	250 ounces	7.39 litres	586 ounces	17.33 litres
ELTM-80 (-2)	340 ounces	10.05 litres	850 ounces	25.12 litres
ELTM-100 (-2)	420 ounces	12.42 litres	1088 ounces	32.17 litres

Replace air vent nut.

Follow AIR VENTING INSTRUCTIONS.

Continue normal operating procedure of kettle.

## **7.0 TROUBLESHOOTING** (Continued)

### **EXTREMELY SLOW COOKING TIME**

1. If the cooking time is abnormally slow, then the difficulty may be due to air being present in the kettle jacket. To remove air, follow AIR VENTING INSTRUCTIONS.
2. If the kettle will not reach and maintain Pressure Gauge zone in the green area on the gauge when cold, a slow leak may have developed in the jacket. Check all fitting connections to jacket including the heating element gasket. Tighten or replace if necessary.
3. Slow cooking time may also be due to a burnt out heating element. Test elements and if defective, replace complete element assembly.

### **KETTLE WILL NOT OPERATE WHEN TURNED ON**

1. Check that power supply is available to kettle.
2. Kettle will not operate if water level is inadequate in jacket. Follow LOW WATER LEVEL instructions.
3. If water level is sufficient and kettle refuses to operate, then check that Tilt Interlock Switch in Console is fully engaged when kettle is in its normally upright position. Adjust Retaining Tilt Collar if necessary to assure complete contact with switch and if kettle still does not operate, then check for defective switch and/or loose wiring connections.
4. When Thermostat Knob is dialed and TEMPERATURE indicator light does not come on, then it may be due to either a defective Thermostat or loose wiring connections(s).
5. Check that the Contactor(s) are being energized and power is being made available to the heating elements when thermostat is dialed. Replace defective Contactor(s).

### **AIR VENTING INSTRUCTIONS**

Check vacuum/pressure gauge when the kettle is cold. Gauge should be in the green vacuum zone, indicating a vacuum between 25-30 In. Hg (630 - 730 mm Hg). If not, air must be vented (removed) for proper heating. Use the following procedures to vent air.

1. Place power switch ON with kettle empty.
2. Set temperature control thermostat to '10'. Heat kettle until indicator light goes off.

INSTALLATION AND OPERATION MANUAL, ELECTRIC SELF GENERATING SINGLE AND TWIN STEAM MIXER KETTLE, MODELS ELTM-40 TO 100 AND ELTM 40-2 TO 100-2

**AIR VENTING INSTRUCTIONS** (Continued)

3. Using a 7/16" wrench, open bleed vent one full turn for 10 seconds and then close. (Located on back of kettle, before pressure relief valve.)



**WARNING: SCALD HAZARD. Live steam will escape the bleed nut when opened. Stay clear of live steam when performing this operation.**

4. Cool kettle. Check for proper vacuum in green area of gauge. If vacuum was not established, repeat steps 1 - 4.

## **7.0 TROUBLESHOOTING** (Continued)

### **HYDRAULIC SYSTEM**

#### **TROUBLESHOOTING:**

#### **SOLENOID VALVES FAILED TO OPERATE**

1. Voltage too low will not complete the stroke of alternating current (AC) and the solenoid will burn out the coil.
2. Signal to both solenoids of a double solenoid valve simultaneously. One or both of the valves will be unable to complete their stroke and burn out. Make certain the electrical signal is interlocked so that this condition cannot exist.
3. Incorrect voltage or frequency will prevent operation or burn out coil.
4. Foreign matter in valve.
5. Oil too hot.

#### **PUMP**

1. Excessive noise caused by vacuum leak in suction line.
2. Misalignment of drive mechanism will cause high noise level in operation.
3. Relief set too high.
4. Return line above fluid level.
5. Reversed rotation.
6. Filter breather plugged.
7. Viscosity of oil too high.
8. Loose or worn pump parts.
9. Air leak at pump shaft seal.
10. Oil too low, drawing in air.
11. Air bubbles in intake oil.

## **7.0 TROUBLESHOOTING** (Continued)

### **EXCESSIVE WEAR**

1. Abrasive material in oil causing wear.
2. Oil viscosity too low.
3. Pump misalignment.
4. Air being drawn in through inlet of pump.
5. System pressure exceeds pump rating.

### **BROKEN INTERNAL PARTS**

1. Lack of oil.
2. Excessive torquing of housing bolts.
3. Solid matter being drawn in from reservoir.

### **DIRTY OIL**

1. Components not cleaned properly after servicing.
2. Air breather left off.
3. Filter dirty or ruptured.

### **FOAMING OIL**

1. Return line not below oil level.
2. Oil contaminated.
3. Suction leak to pump.

### **MOISTURE IN OIL**

1. Water in oil supply.
2. Extreme temperature differential.

**7.0 TROUBLESHOOTING** (Continued)

**OVERHEATING OF SYSTEM**

1. Continuous operation at relief setting.
  - 1) Stalling under load.
  - 2) Viscosity of oil too high.
2. Excessive slippage or internal leakage. Fluid too low.
3. System relief valve set too high.
4. Power unit ambient too high.
5. Insufficient volume of water supply to oil cooler.

INSTALLATION AND OPERATION MANUAL, ELECTRIC SELF GENERATING SINGLE AND TWIN STEAM MIXER KETTLE, MODELS ELTM-40 TO 100 AND ELTM 40-2 TO 100-2



**SAFETY DATA SHEET**  
DOW CHEMICAL CANADA ULC

**Product name:** DOWFROST™ HD Heat Transfer Fluid, Dyed

**Issue Date:** 01/19/2017

**Print Date:** 01/23/2017

DOW CHEMICAL CANADA ULC encourages and expects you to read and understand the entire (M)SDS, as there is important information throughout the document. We expect you to follow the precautions identified in this document unless your use conditions would necessitate other appropriate methods or actions.

---

### 1. IDENTIFICATION

---

**Product name:** DOWFROST™ HD Heat Transfer Fluid, Dyed

**Recommended use of the chemical and restrictions on use**

**Identified uses:** Intended as a heat transfer fluid for closed-loop systems. We recommend that you use this product in a manner consistent with the listed use. If your intended use is not consistent with the stated use, please contact your sales or technical service representative.

**COMPANY IDENTIFICATION**

DOW CHEMICAL CANADA ULC  
#2400, 215 - 2ND STREET S.W.  
CALGARY AB T2P 1M4  
CANADA

**Customer Information Number:**

800-258-2436

SDSQuestion@dow.com

**EMERGENCY TELEPHONE NUMBER**

**24-Hour Emergency Contact:** 1-888-226-8832

**Local Emergency Contact:** 613-996-6666

---

### 2. HAZARDS IDENTIFICATION

---

**Hazard classification**

This product is not hazardous under the criteria of the Hazardous Products Regulation (HPR) as implemented under the Workplace Hazardous Materials Information System (WHMIS 2015).

**Other hazards**

No data available

---

### 3. COMPOSITION/INFORMATION ON INGREDIENTS

---

This product is a mixture.

<b>Component</b>	<b>CASRN</b>	<b>Concentration</b>
------------------	--------------	----------------------

---

# INSTALLATION AND OPERATION MANUAL, ELECTRIC SELF GENERATING SINGLE AND TWIN STEAM MIXER KETTLE, MODELS ELTM-40 TO 100 AND ELTM 40-2 TO 100-2

**Product name:** DOWFROST™ HD Heat Transfer Fluid, Dyed

**Issue Date:** 01/19/2017

Propylene glycol	57-55-6	> 93.0 %
Water	7732-18-5	< 5.0 %
Dipotassium hydrogen phosphate	7758-11-4	< 5.0 %

---

## 4. FIRST AID MEASURES

---

### Description of first aid measures

**General advice:** If potential for exposure exists refer to Section 8 for specific personal protective equipment.

**Inhalation:** Move person to fresh air; if effects occur, consult a physician.

**Skin contact:** Wash off with plenty of water.

**Eye contact:** Flush eyes thoroughly with water for several minutes. Remove contact lenses after the initial 1-2 minutes and continue flushing for several additional minutes. If effects occur, consult a physician, preferably an ophthalmologist.

**Ingestion:** No emergency medical treatment necessary.

**Most important symptoms and effects, both acute and delayed:** Aside from the information found under Description of first aid measures (above) and Indication of immediate medical attention and special treatment needed (below), any additional important symptoms and effects are described in Section 11: Toxicology Information.

### Indication of any immediate medical attention and special treatment needed

**Notes to physician:** No specific antidote. Treatment of exposure should be directed at the control of symptoms and the clinical condition of the patient.

---

## 5. FIREFIGHTING MEASURES

---

**Suitable extinguishing media:** Water fog or fine spray. Dry chemical fire extinguishers. Carbon dioxide fire extinguishers. Foam. Alcohol resistant foams (ATC type) are preferred. General purpose synthetic foams (including AFFF) or protein foams may function, but will be less effective.

**Unsuitable extinguishing media:** Do not use direct water stream. May spread fire.

### Special hazards arising from the substance or mixture

**Hazardous combustion products:** During a fire, smoke may contain the original material in addition to combustion products of varying composition which may be toxic and/or irritating. Combustion products may include and are not limited to: Carbon monoxide. Carbon dioxide.

**Unusual Fire and Explosion Hazards:** Container may rupture from gas generation in a fire situation. Violent steam generation or eruption may occur upon application of direct water stream to hot liquids.

# INSTALLATION AND OPERATION MANUAL, ELECTRIC SELF GENERATING SINGLE AND TWIN STEAM MIXER KETTLE, MODELS ELTM-40 TO 100 AND ELTM 40-2 TO 100-2

**Product name:** DOWFROST™ HD Heat Transfer Fluid, Dyed

**Issue Date:** 01/19/2017

## Advice for firefighters

**Fire Fighting Procedures:** Keep people away. Isolate fire and deny unnecessary entry. Use water spray to cool fire exposed containers and fire affected zone until fire is out and danger of reignition has passed. Fight fire from protected location or safe distance. Consider the use of unmanned hose holders or monitor nozzles. Immediately withdraw all personnel from the area in case of rising sound from venting safety device or discoloration of the container. Burning liquids may be extinguished by dilution with water. Do not use direct water stream. May spread fire. Move container from fire area if this is possible without hazard. Burning liquids may be moved by flushing with water to protect personnel and minimize property damage.

**Special protective equipment for firefighters:** Wear positive-pressure self-contained breathing apparatus (SCBA) and protective fire fighting clothing (includes fire fighting helmet, coat, trousers, boots, and gloves). If protective equipment is not available or not used, fight fire from a protected location or safe distance.

---

## 6. ACCIDENTAL RELEASE MEASURES

---

**Personal precautions, protective equipment and emergency procedures:** Keep unnecessary and unprotected personnel from entering the area. Use appropriate safety equipment. For additional information, refer to Section 8, Exposure Controls and Personal Protection.

**Environmental precautions:** Prevent from entering into soil, ditches, sewers, waterways and/or groundwater. See Section 12, Ecological Information.

**Methods and materials for containment and cleaning up:** Small spills: Absorb with materials such as: Cat litter. Sawdust. Vermiculite. Zorb-all®. Collect in suitable and properly labeled containers. Large spills: Dike area to contain spill. See Section 13, Disposal Considerations, for additional information.

---

## 7. HANDLING AND STORAGE

---

**Precautions for safe handling; Conditions for safe storage:** Do not store in: Galvanized steel. Opened or unlabeled containers. Store in the following material(s): Carbon steel. Stainless steel. Store in original unopened container. See Section 10 for more specific information. Additional storage and handling information on this product may be obtained by calling your sales or customer service contact.

---

## 8. EXPOSURE CONTROLS/PERSONAL PROTECTION

---

### Control parameters

Exposure limits are listed below, if they exist.

Component	Regulation	Type of listing	Value/Notation
Propylene glycol	US WEEL	TWA	10 mg/m <sup>3</sup>
	CA ON OEL	TWAEV Total	155 mg/m <sup>3</sup> 50 ppm
	CA ON OEL	TWAEV	10 mg/m <sup>3</sup>
	CA ON OEL	TWA	155 mg/m <sup>3</sup> 50 ppm
	CA ON OEL	TWA	10 mg/m <sup>3</sup>
	CA ON OEL	TWA Vapour and aerosols	155 mg/m <sup>3</sup> 50 ppm
	CA ON OEL	TWA aerosol	10 mg/m <sup>3</sup>

# INSTALLATION AND OPERATION MANUAL, ELECTRIC SELF GENERATING SINGLE AND TWIN STEAM MIXER KETTLE, MODELS ELTM-40 TO 100 AND ELTM 40-2 TO 100-2

**Product name:** DOWFROST™ HD Heat Transfer Fluid, Dyed

**Issue Date:** 01/19/2017

Consult local authorities for recommended exposure limits.

## Exposure controls

**Engineering controls:** Use local exhaust ventilation, or other engineering controls to maintain airborne levels below exposure limit requirements or guidelines. If there are no applicable exposure limit requirements or guidelines, general ventilation should be sufficient for most operations. Local exhaust ventilation may be necessary for some operations.

## Individual protection measures

**Eye/face protection:** Use safety glasses (with side shields).

### Skin protection

**Hand protection:** Use gloves chemically resistant to this material when prolonged or frequently repeated contact could occur. Examples of preferred glove barrier materials include: Butyl rubber. Natural rubber ("latex"). Neoprene. Nitrile/butadiene rubber ("nitrile" or "NBR"). Polyethylene. Ethyl vinyl alcohol laminate ("EVAL"). Polyvinyl alcohol ("PVA"). Polyvinyl chloride ("PVC" or "vinyl"). NOTICE: The selection of a specific glove for a particular application and duration of use in a workplace should also take into account all relevant workplace factors such as, but not limited to: Other chemicals which may be handled, physical requirements (cut/puncture protection, dexterity, thermal protection), potential body reactions to glove materials, as well as the instructions/specifications provided by the glove supplier.

**Other protection:** Wear clean, body-covering clothing.

**Respiratory protection:** Respiratory protection should be worn when there is a potential to exceed the exposure limit requirements or guidelines. If there are no applicable exposure limit requirements or guidelines, wear respiratory protection when adverse effects, such as respiratory irritation or discomfort have been experienced, or where indicated by your risk assessment process. In misty atmospheres, use an approved particulate respirator. The following should be effective types of air-purifying respirators: Organic vapor cartridge with a particulate pre-filter.

---

## 9. PHYSICAL AND CHEMICAL PROPERTIES

---

### Appearance

<b>Physical state</b>	Liquid.
<b>Color</b>	Yellow to green
<b>Odor</b>	Characteristic
<b>Odor Threshold</b>	No test data available
<b>pH</b>	9.5 50% <i>Literature</i>
<b>Melting point/range</b>	Not applicable to liquids
<b>Freezing point</b>	supercools
<b>Boiling point (760 mmHg)</b>	152 °C <i>Literature</i>
<b>Flash point</b>	<b>closed cup</b> 104 °C <i>Pensky-Martens Closed Cup ASTM D 93</i> Propylene glycol., (based on major component)
<b>Evaporation Rate (Butyl Acetate = 1)</b>	< 0.5 <i>Estimated.</i>
<b>Flammability (solid, gas)</b>	Not applicable to liquids
<b>Lower explosion limit</b>	2.6 % vol <i>Literature</i> Propylene glycol.
<b>Upper explosion limit</b>	12.5 % vol <i>Literature</i> Propylene glycol.

# INSTALLATION AND OPERATION MANUAL, ELECTRIC SELF GENERATING SINGLE AND TWIN STEAM MIXER KETTLE, MODELS ELTM-40 TO 100 AND ELTM 40-2 TO 100-2

**Product name:** DOWFROST™ HD Heat Transfer Fluid, Dyed

**Issue Date:** 01/19/2017

<b>Vapor Pressure</b>	2.2 mmHg <i>Literature</i>
<b>Relative Vapor Density (air = 1)</b>	>1.0 <i>Literature</i>
<b>Relative Density (water = 1)</b>	1.06 at 20 °C / 20 °C <i>Literature</i>
<b>Water solubility</b>	100 % <i>Literature</i>
<b>Partition coefficient: n-octanol/water</b>	No data available
<b>Auto-ignition temperature</b>	371 °C <i>Literature</i> Propylene glycol.
<b>Decomposition temperature</b>	No test data available
<b>Kinematic Viscosity</b>	43.4 cSt at 20 °C <i>Literature</i>
<b>Explosive properties</b>	No data available
<b>Oxidizing properties</b>	No data available
<b>Molecular weight</b>	No data available

NOTE: The physical data presented above are typical values and should not be construed as a specification.

---

## 10. STABILITY AND REACTIVITY

---

**Reactivity:** No data available

**Chemical stability:** Stable under recommended storage conditions. See Storage, Section 7.  
Hygroscopic

**Possibility of hazardous reactions:** Polymerization will not occur.

**Conditions to avoid:** Exposure to elevated temperatures can cause product to decompose. Generation of gas during decomposition can cause pressure in closed systems. Avoid direct sunlight or ultraviolet sources.

**Incompatible materials:** Avoid contact with: Strong acids. Strong bases. Strong oxidizers.

**Hazardous decomposition products:** Decomposition products depend upon temperature, air supply and the presence of other materials. Decomposition products can include and are not limited to: Aldehydes. Alcohols. Ethers. Organic acids.

---

## 11. TOXICOLOGICAL INFORMATION

---

*Toxicological information appears in this section when such data is available.*

### Acute toxicity

#### Acute oral toxicity

Very low toxicity if swallowed. Harmful effects not anticipated from swallowing small amounts.

For the major component(s): Propylene glycol.  
LD50, Rat, > 20,000 mg/kg

#### Acute dermal toxicity

Prolonged skin contact is unlikely to result in absorption of harmful amounts.

# INSTALLATION AND OPERATION MANUAL, ELECTRIC SELF GENERATING SINGLE AND TWIN STEAM MIXER KETTLE, MODELS ELTM-40 TO 100 AND ELTM 40-2 TO 100-2

**Product name:** DOWFROST™ HD Heat Transfer Fluid, Dyed

**Issue Date:** 01/19/2017

---

For the major component(s): Propylene glycol.  
LD50, Rabbit, > 20,000 mg/kg

#### **Acute inhalation toxicity**

At room temperature, exposure to vapor is minimal due to low volatility. Mist may cause irritation of upper respiratory tract (nose and throat).

For the major component(s):  
LC50, Rat, 4 Hour, vapour, 6.15 mg/l No deaths occurred following exposure to a saturated atmosphere.

#### **Skin corrosion/irritation**

Prolonged contact is essentially nonirritating to skin.  
Repeated contact may cause flaking and softening of skin.

#### **Serious eye damage/eye irritation**

May cause slight temporary eye irritation.  
Corneal injury is unlikely.

#### **Sensitization**

For the major component(s):  
Did not cause allergic skin reactions when tested in humans.

For respiratory sensitization:  
No relevant data found.

#### **Specific Target Organ Systemic Toxicity (Single Exposure)**

Evaluation of available data suggests that this material is not an STOT-SE toxicant.

#### **Specific Target Organ Systemic Toxicity (Repeated Exposure)**

In rare cases, repeated excessive exposure to propylene glycol may cause central nervous system effects.

#### **Carcinogenicity**

Similar formulations did not cause cancer in laboratory animals.

#### **Teratogenicity**

For the major component(s): Did not cause birth defects or any other fetal effects in laboratory animals.

#### **Reproductive toxicity**

For the major component(s): In animal studies, did not interfere with reproduction. In animal studies, did not interfere with fertility.

#### **Mutagenicity**

In vitro genetic toxicity studies were negative. For the major component(s): Animal genetic toxicity studies were negative.

#### **Aspiration Hazard**

Based on physical properties, not likely to be an aspiration hazard.

# INSTALLATION AND OPERATION MANUAL, ELECTRIC SELF GENERATING SINGLE AND TWIN STEAM MIXER KETTLE, MODELS ELTM-40 TO 100 AND ELTM 40-2 TO 100-2

**Product name: DOWFROST™ HD Heat Transfer Fluid, Dyed**

**Issue Date: 01/19/2017**

---

## 12. ECOLOGICAL INFORMATION

---

*Ecotoxicological information appears in this section when such data is available.*

### **Toxicity**

#### **Propylene glycol**

##### **Acute toxicity to fish**

Material is practically non-toxic to aquatic organisms on an acute basis (LC50/EC50/EL50/LL50 >100 mg/L in the most sensitive species tested).  
LC50, Oncorhynchus mykiss (rainbow trout), static test, 96 Hour, 40,613 mg/l, OECD Test Guideline 203

##### **Acute toxicity to aquatic invertebrates**

LC50, Ceriodaphnia dubia (water flea), static test, 48 Hour, 18,340 mg/l, OECD Test Guideline 202

##### **Acute toxicity to algae/aquatic plants**

ErC50, Pseudokirchneriella subcapitata (green algae), 96 Hour, Growth rate inhibition, 19,000 mg/l, OECD Test Guideline 201

##### **Toxicity to bacteria**

NOEC, Pseudomonas putida, 18 Hour, > 20,000 mg/l

##### **Chronic toxicity to aquatic invertebrates**

NOEC, Ceriodaphnia dubia (water flea), semi-static test, 7 d, number of offspring, 13,020 mg/l

#### **Dipotassium hydrogen phosphate**

##### **Acute toxicity to fish**

Material is practically non-toxic to aquatic organisms on an acute basis (LC50/EC50/EL50/LL50 >100 mg/L in the most sensitive species tested).  
LC50, Leuciscus idus (Golden orfe), static test, 48 Hour, > 900 mg/l, Method Not Specified.

### **Persistence and degradability**

#### **Propylene glycol**

**Biodegradability:** Material is readily biodegradable. Passes OECD test(s) for ready biodegradability. Biodegradation may occur under anaerobic conditions (in the absence of oxygen).

10-day Window: Pass

**Biodegradation:** 81 %

**Exposure time:** 28 d

**Method:** OECD Test Guideline 301F or Equivalent

10-day Window: Not applicable

**Biodegradation:** 96 %

**Exposure time:** 64 d

**Method:** OECD Test Guideline 306 or Equivalent

**Theoretical Oxygen Demand:** 1.68 mg/mg

**Chemical Oxygen Demand:** 1.53 mg/mg

# INSTALLATION AND OPERATION MANUAL, ELECTRIC SELF GENERATING SINGLE AND TWIN STEAM MIXER KETTLE, MODELS ELTM-40 TO 100 AND ELTM 40-2 TO 100-2

**Product name:** DOWFROST™ HD Heat Transfer Fluid, Dyed

**Issue Date:** 01/19/2017

## Biological oxygen demand (BOD)

Incubation Time	BOD
5 d	69.000 %
10 d	70.000 %
20 d	86.000 %

## Photodegradation

**Atmospheric half-life:** 10 Hour

**Method:** Estimated.

## Dipotassium hydrogen phosphate

**Biodegradability:** Biodegradation is not applicable.

## Bioaccumulative potential

### Propylene glycol

**Bioaccumulation:** Bioconcentration potential is low (BCF < 100 or Log Pow < 3).

**Partition coefficient: n-octanol/water(log Pow):** -1.07 Measured

**Bioconcentration factor (BCF):** 0.09 Estimated.

### Dipotassium hydrogen phosphate

**Bioaccumulation:** No bioconcentration is expected because of the relatively high water solubility.

## Mobility in soil

### Propylene glycol

Given its very low Henry's constant, volatilization from natural bodies of water or moist soil is not expected to be an important fate process.

Potential for mobility in soil is very high (Koc between 0 and 50).

**Partition coefficient (Koc):** < 1 Estimated.

### Dipotassium hydrogen phosphate

No relevant data found.

---

## 13. DISPOSAL CONSIDERATIONS

---

**Disposal methods:** DO NOT DUMP INTO ANY SEWERS, ON THE GROUND, OR INTO ANY BODY OF WATER. All disposal practices must be in compliance with all Federal, State/Provincial and local laws and regulations. Regulations may vary in different locations. Waste characterizations and compliance with applicable laws are the responsibility solely of the waste generator. AS YOUR SUPPLIER, WE HAVE NO CONTROL OVER THE MANAGEMENT PRACTICES OR MANUFACTURING PROCESSES OF PARTIES HANDLING OR USING THIS MATERIAL. THE INFORMATION PRESENTED HERE PERTAINS ONLY TO THE PRODUCT AS SHIPPED IN ITS INTENDED CONDITION AS DESCRIBED IN MSDS SECTION: Composition Information. FOR UNUSED & UNCONTAMINATED PRODUCT, the preferred options include sending to a licensed, permitted: Recycler. Reclaimer. Incinerator or other thermal destruction device.

INSTALLATION AND OPERATION MANUAL, ELECTRIC SELF GENERATING SINGLE AND TWIN STEAM MIXER KETTLE, MODELS ELTM-40 TO 100 AND ELTM 40-2 TO 100-2

**Product name: DOWFROST™ HD Heat Transfer Fluid, Dyed**

**Issue Date: 01/19/2017**

---

---

**14. TRANSPORT INFORMATION**

---

**TDG**

Not regulated for transport

**Classification for SEA transport (IMO-IMDG):**

Not regulated for transport

**Transport in bulk according to Annex I or II of MARPOL 73/78 and the IBC or IGC Code**

Consult IMO regulations before transporting ocean bulk

**Classification for AIR transport (IATA/ICAO):**

Not regulated for transport

This information is not intended to convey all specific regulatory or operational requirements/information relating to this product. Transportation classifications may vary by container volume and may be influenced by regional or country variations in regulations. Additional transportation system information can be obtained through an authorized sales or customer service representative. It is the responsibility of the transporting organization to follow all applicable laws, regulations and rules relating to the transportation of the material.

---

---

**15. REGULATORY INFORMATION**

---

**Canadian Domestic Substances List (DSL)**

This product contains at least one substance which is not listed on the Canadian Domestic Substances List (DSL).

---

---

**16. OTHER INFORMATION**

---

**Hazard Rating System**

**NFPA**

Health	Fire	Reactivity
0	1	0

**Revision**

Identification Number: 101199333 / A208 / Issue Date: 01/19/2017 / Version: 7.0

Most recent revision(s) are noted by the bold, double bars in left-hand margin throughout this document.

**Legend**

CA ON OEL	Canada, Ontario OELs
-----------	----------------------

# INSTALLATION AND OPERATION MANUAL, ELECTRIC SELF GENERATING SINGLE AND TWIN STEAM MIXER KETTLE, MODELS ELTM-40 TO 100 AND ELTM 40-2 TO 100-2

**Product name: DOWFROST™ HD Heat Transfer Fluid, Dyed**

**Issue Date: 01/19/2017**

TWA	8-hr Time Weighted Average
TWAEV	time-weighted average exposure value
US WEEL	USA. Workplace Environmental Exposure Levels (WEEL)

## Information Source and References

This SDS is prepared by Product Regulatory Services and Hazard Communications Groups from information supplied by internal references within our company.

DOW CHEMICAL CANADA ULC urges each customer or recipient of this (M)SDS to study it carefully and consult appropriate expertise, as necessary or appropriate, to become aware of and understand the data contained in this (M)SDS and any hazards associated with the product. The information herein is provided in good faith and believed to be accurate as of the effective date shown above. However, no warranty, express or implied, is given. Regulatory requirements are subject to change and may differ between various locations. It is the buyer's/user's responsibility to ensure that his activities comply with all federal, state, provincial or local laws. The information presented here pertains only to the product as shipped. Since conditions for use of the product are not under the control of the manufacturer, it is the buyer's/user's duty to determine the conditions necessary for the safe use of this product. Due to the proliferation of sources for information such as manufacturer-specific (M)SDSs, we are not and cannot be responsible for (M)SDSs obtained from any source other than ourselves. If you have obtained an (M)SDS from another source or if you are not sure that the (M)SDS you have is current, please contact us for the most current version.

INSTALLATION AND OPERATION MANUAL, ELECTRIC SELF GENERATING SINGLE AND TWIN STEAM MIXER KETTLE, MODELS ELTM-40 TO 100 AND ELTM 40-2 TO 100-2



## SAFETY DATA SHEET

### 1. Identification

<b>Product name</b>	FM HYDRAULIC OIL 32
<b>Other means of identification</b>	No data available.
<b>Recommended use:</b>	Lubricating fluid
<b>Restrictions on use:</b>	Industrial use only

#### Manufacturer/Importer/Supplier/Distributor Information

##### Manufacturer

Company Name:	Fuchs Lubricants Co.
Address:	17050 Lathrop Avenue Harvey, Illinois 60426
Telephone:	708-333-8900
Fax:	708-333-9180
Contact Person:	EHS Department
E-mail:	sds@fuchsus.com

**Emergency telephone number:** 708-333-8900 (Bus. hrs) 800-255-3924 (24 hrs)

### 2. Hazard(s) identification

<b>Hazard Classification</b>	Not classified as hazardous under 29CFR 1910.1200 (HazCom 2012).
------------------------------	--

#### Label Elements

<b>Hazard Symbol:</b>	No symbol
<b>Signal Word:</b>	No signal word.
<b>Hazard Statement:</b>	not applicable
<b>Precautionary Statement</b>	not applicable

<b>Other hazards which do not result in GHS classification:</b>	None.
---	-------

### 3. Composition/information on ingredients

INSTALLATION AND OPERATION MANUAL, ELECTRIC SELF GENERATING SINGLE AND TWIN STEAM MIXER KETTLE, MODELS ELTM-40 TO 100 AND ELTM 40-2 TO 100-2



## SAFETY DATA SHEET

### Hazardous Component(s):

Chemical name	CAS-No.	Concentration
White mineral oil	Confidential	60 - 100%

Specific chemical identities and/or exact percentages have been withheld as trade secrets.

### 4. First-aid measures

<b>Ingestion:</b>	Rinse mouth thoroughly. Call a POISON CENTER/doctor/.../if you feel unwell. Do NOT induce vomiting.
<b>Inhalation:</b>	Move to fresh air. Call a POISON CENTER/doctor/.../if you feel unwell.
<b>Skin Contact:</b>	Remove contaminated/saturated clothing and shoes. Wash contact areas with soap and water. If skin irritation occurs: Get medical advice/attention.
<b>Eye contact:</b>	Flush thoroughly with water. If irritation occurs, get medical assistance. Continue to rinse for at least 15 minutes.

### Most important symptoms/effects, acute and delayed

**Symptoms:** No data available.

### Indication of immediate medical attention and special treatment needed

**Treatment:** Get medical attention as appropriate or if symptoms persist.

### 5. Fire-fighting measures

**General Fire Hazards:** No unusual fire or explosion hazards noted.

### Suitable (and unsuitable) extinguishing media

**Suitable extinguishing media:** Water spray, fog, CO<sub>2</sub>, dry chemical, or regular foam. Use fire-extinguishing media appropriate for surrounding materials.

**Unsuitable extinguishing media:** Do not use water jet as an extinguisher, as this will spread the fire.

**Specific hazards arising from the chemical:** Heat may cause the containers to explode. During fire, gases hazardous to health may be formed.

### Special protective equipment and precautions for firefighters

**Special fire fighting procedures:** No data available.

INSTALLATION AND OPERATION MANUAL, ELECTRIC SELF GENERATING SINGLE AND TWIN STEAM MIXER KETTLE, MODELS ELTM-40 TO 100 AND ELTM 40-2 TO 100-2



## SAFETY DATA SHEET

**Special protective equipment for fire-fighters:** Firefighters must use standard protective equipment including flame retardant coat, helmet with face shield, gloves, rubber boots, and in enclosed spaces, SCBA.

### 6. Accidental release measures

**Personal precautions, protective equipment and emergency procedures:** See Section 8 of the SDS for Personal Protective Equipment. Do not touch damaged containers or spilled material unless wearing appropriate protective clothing. Keep unauthorized personnel away. Ensure adequate ventilation.

**Methods and material for containment and cleaning up:** Absorb with sand or other inert absorbent. Stop the flow of material, if this is without risk.

**Environmental Precautions:** Avoid release to the environment. Do not contaminate water sources or sewer. Prevent further leakage or spillage if safe to do so.

### 7. Handling and storage

**Precautions for safe handling:** Observe good industrial hygiene practices. Wear appropriate personal protective equipment. Do not expose to intense heat as product may expand and pressurize container.

**Conditions for safe storage, including any incompatibilities:** Store in original tightly closed container. Avoid contact with oxidizing agents. Store away from incompatible materials.

### 8. Exposure controls/personal protection

#### Exposure Limits

Chemical name	type	Exposure Limit Values	Source
White mineral oil - Inhalable fraction.	TWA	5 mg/m <sup>3</sup>	US. ACGIH Threshold Limit Values (03 2012)
White mineral oil - Mist.	PEL	5 mg/m <sup>3</sup>	US. OSHA Table Z-1 Limits for Air Contaminants (29 CFR 1910.1000) (02 2006)

**Protective Measures:** Use personal protective equipment as required.

**Respiratory Protection:** In case of inadequate ventilation use suitable respirator. Seek advice from supervisor on the company's respiratory protection standards.

**Eye Protection:** Wear safety glasses with side shields (or goggles).

**Skin and Body Protection:** Wear chemical-resistant gloves, footwear, and protective clothing appropriate for the risk of exposure. Contact health and safety professional or manufacturer for specific information.



## SAFETY DATA SHEET

**Hygiene measures:** Always observe good personal hygiene measures, such as washing after handling the material and before eating, drinking, and/or smoking. Routinely wash work clothing to remove contaminants. Contaminated work clothing should not be allowed out of the workplace. Discard contaminated footwear that cannot be cleaned. Avoid contact with skin, eyes, and clothing.

### 9. Physical and chemical properties

#### Appearance

<b>Physical state:</b>	Liquid
<b>Form:</b>	No data available.
<b>Color:</b>	Water-white
<b>Odor:</b>	Mild
<b>Odor threshold:</b>	No data available.
<b>pH:</b>	No data available.
<b>Melting point/freezing point:</b>	No data available.
<b>Initial boiling point and boiling range:</b>	No data available.
<b>Flash Point:</b>	> 100 °C (212 °F)
<b>Evaporation rate:</b>	No data available.
<b>Flammability (solid, gas):</b>	No data available.
<b>Upper/lower limit on flammability or explosive limits</b>	
<b>Flammability limit - upper (%):</b>	No data available.
<b>Flammability limit - lower (%):</b>	No data available.
<b>Explosive limit - upper (%):</b>	No data available.
<b>Explosive limit - lower (%):</b>	No data available.
<b>Vapor pressure:</b>	No data available.
<b>Vapor density:</b>	No data available.
<b>Relative density:</b>	0.8607
<b>Solubility(ies)</b>	
<b>Solubility in water:</b>	Insoluble
<b>Solubility (other):</b>	No data available.
<b>Partition coefficient (n-octanol/water):</b>	No data available.
<b>Auto-ignition temperature:</b>	No data available.
<b>Decomposition temperature:</b>	No data available.
<b>Viscosity:</b>	32 mm <sup>2</sup> /s (40 °C)

### 10. Stability and reactivity

**Reactivity:** Not reactive during normal use.

**Chemical Stability:** Material is stable under normal conditions.

INSTALLATION AND OPERATION MANUAL, ELECTRIC SELF GENERATING SINGLE AND TWIN STEAM MIXER KETTLE, MODELS ELTM-40 TO 100 AND ELTM 40-2 TO 100-2



LUBRICANTS.  
TECHNOLOGY.  
PEOPLE.

## SAFETY DATA SHEET

<b>Possibility of hazardous reactions:</b>	None under normal conditions.
<b>Conditions to avoid:</b>	Avoid heat or contamination.
<b>Incompatible Materials:</b>	No data available.
<b>Hazardous Decomposition Products:</b>	Thermal decomposition or combustion may liberate carbon oxides and other toxic gases or vapors.

### 11. Toxicological information

#### Information on likely routes of exposure

<b>Ingestion:</b>	May be ingested by accident. Ingestion may cause irritation and malaise.
<b>Inhalation:</b>	Inhalation is the primary route of exposure. In high concentrations, vapors, fumes or mists may irritate nose, throat and mucus membranes.
<b>Skin Contact:</b>	Prolonged skin contact may cause redness and irritation.
<b>Eye contact:</b>	Eye contact is possible and should be avoided.

#### Symptoms related to the physical, chemical and toxicological characteristics

<b>Ingestion:</b>	No data available.
<b>Inhalation:</b>	No data available.
<b>Skin Contact:</b>	No data available.
<b>Eye contact:</b>	No data available.

#### Information on toxicological effects

##### Acute toxicity (list all possible routes of exposure)

<b>Oral Product:</b>	Not classified for acute toxicity based on available data.
<b>Dermal Product:</b>	ATEmix (): 2000 - 5000 mg/kg
<b>Inhalation Product:</b>	Not classified for acute toxicity based on available data.

<b>Repeated dose toxicity Product:</b>	No data available.
--	--------------------

<b>Skin Corrosion/Irritation Product:</b>	No data available.
---	--------------------

SDS\_US

5/8

INSTALLATION AND OPERATION MANUAL, ELECTRIC SELF GENERATING SINGLE AND TWIN STEAM MIXER KETTLE, MODELS ELTM-40 TO 100 AND ELTM 40-2 TO 100-2



## SAFETY DATA SHEET

### Serious Eye Damage/Eye Irritation

Product: No data available.

### Respiratory or Skin Sensitization

Product: No data available.

### Carcinogenicity

Product: No data available.

#### IARC Monographs on the Evaluation of Carcinogenic Risks to Humans:

No carcinogenic components identified

#### US. National Toxicology Program (NTP) Report on Carcinogens:

No carcinogenic components identified

#### US. OSHA Specifically Regulated Substances (29 CFR 1910.1001-1050):

No carcinogenic components identified

### Germ Cell Mutagenicity

#### In vitro

Product: No data available.

#### In vivo

Product: No data available.

### Reproductive toxicity

Product: No data available.

### Specific Target Organ Toxicity - Single Exposure

Product: No data available.

### Specific Target Organ Toxicity - Repeated Exposure

Product: No data available.

### Aspiration Hazard

Product: No data available.

Other effects: No data available.

## 12. Ecological information

General information: This product has not been evaluated for ecological toxicity or other environmental effects.

## 13. Disposal considerations

INSTALLATION AND OPERATION MANUAL, ELECTRIC SELF GENERATING SINGLE AND TWIN STEAM MIXER KETTLE, MODELS ELTM-40 TO 100 AND ELTM 40-2 TO 100-2



## SAFETY DATA SHEET

**Disposal instructions:** Discharge, treatment, or disposal may be subject to national, state, or local laws. Dispose of waste at an appropriate treatment and disposal facility in accordance with applicable laws and regulations, and product characteristics at time of disposal. It is the responsibility of the product user or owner to determine at the time of disposal, which waste regulations must be applied.

**Contaminated Packaging:** Empty containers should be taken to an approved waste handling site for recycling or disposal.

### 14. Transport information

**DOT**  
Not regulated.

**IMDG**  
Not regulated.

**IATA**  
Not regulated.

### 15. Regulatory information

#### US Federal Regulations

**US. OSHA Specifically Regulated Substances (29 CFR 1910.1001-1050)**  
None present or none present in regulated quantities.

#### Superfund Amendments and Reauthorization Act of 1986 (SARA)

**Hazard categories**  
None

**SARA 313 (TRI Reporting)**  
None present or none present in regulated quantities.

#### US State Regulations

**US. California Proposition 65**  
No component is regulated by CA Prop 65.

### 16. Other information, including date of preparation or last revision

**Issue Date:** 24.06.2016

**Revision Date:** 24.06.2016

**Version #:** 1.0

INSTALLATION AND OPERATION MANUAL, ELECTRIC SELF GENERATING SINGLE AND  
TWIN STEAM MIXER KETTLE, MODELS ELTM-40 TO 100 AND ELTM 40-2 TO 100-2



## SAFETY DATA SHEET

---

**Further Information:** No data available.

**Disclaimer:** This information is provided without warranty. The information is believed to be correct. This information should be used to make an independent determination of the methods to safeguard workers and the environment.