



IMPORTANT FOR FUTURE REFERENCE Please complete this information and retain this manual for the life of the equipment:
Model #: _____
Serial #: _____
Date Purchased: _____

Installation & Operation Manual

Gas Skillets GMTS-30, GMTS-40 & GMTS-60



Model GMTS-60

WARNING

Improper installation, adjustment, alteration, service or maintenance can cause property damage, injury or death. Read the installation, operating and maintenance instructions thoroughly before installing or servicing this equipment.

CROWN FOOD SERVICE EQUIPMENT

 A Middleby Company

70 Oakdale Road, Downsview (Toronto) Ontario, Canada, M3N 1V9

Telephone: 919-762-1000

www.crownsteamgroup.com



SAFETY PRECAUTIONS

Before installing and operating this equipment, be sure everyone involved in its operation is fully trained and aware of precautions. Accidents and problems can be caused by failure to follow fundamental rules and precautions.

The following symbols, found throughout this manual, alert you to potentially dangerous conditions to the operator, service personnel, or to the equipment.



This symbol warns of immediate hazards that will result in severe injury or death.



This symbol refers to a potential hazard or unsafe practice that could result in injury or death.



This symbol refers to a potential hazard or unsafe practice that could result in injury, product damage, or property damage.



This symbol refers to information that needs special attention or must be fully understood, even though not dangerous.

IMPORTANT NOTES FOR INSTALLATION AND OPERATION

WARNING

This is the safety alert symbol. It is used to alert you to potential personal injury hazards. Obey all safety messages that follow this symbol to avoid possible injury or death.

WARNING

FOR YOUR SAFETY:

Do not store or use gasoline or other flammable vapors or liquids in the vicinity of this or any other appliance.

WARNING

Improper installation, operation, adjustment, alteration, service or maintenance can cause property damage, injury or death. Read the installation, operating and maintenance instructions thoroughly before installing, operating or servicing this equipment.

WARNING

In the event you smell gas, shut down equipment at the main shut off valve and contact the local gas company or gas supplier for service.

NOTICE

Do not attempt to operate this unit in the event of a power failure.

PURCHASER: Instructions to be followed in the event the operator of this appliance smells gas must be posted in a prominent location. This information shall be obtained by consulting the local gas supplier.

The appliance area **MUST** be kept free and clear of combustibles.

DO NOT obstruct the flow of combustion and ventilation air.

Adequate clearances **MUST** be maintained for servicing and proper operation.

Contact the factory, the factory representative or a local service company to perform maintenance and repairs should the appliance malfunction. Refer to warranty terms.

NOTICE

This product is intended for commercial use only. NOT FOR HOUSEHOLD USE.

NOTICE

This manual should be retained for future reference.

RETAIN THIS MANUAL FOR FUTURE REFERENCE.

Table of Contents

Important Notes For Installation and Operation	2
Service Connections	4
Installation Instructions	6
Operating Instructions.....	8
Cleaning.....	10
Cooking Guidelines.....	11
Maintenance	12
Troubleshooting	14
Material Safety Data Sheets	16

SERVICE CONNECTIONS

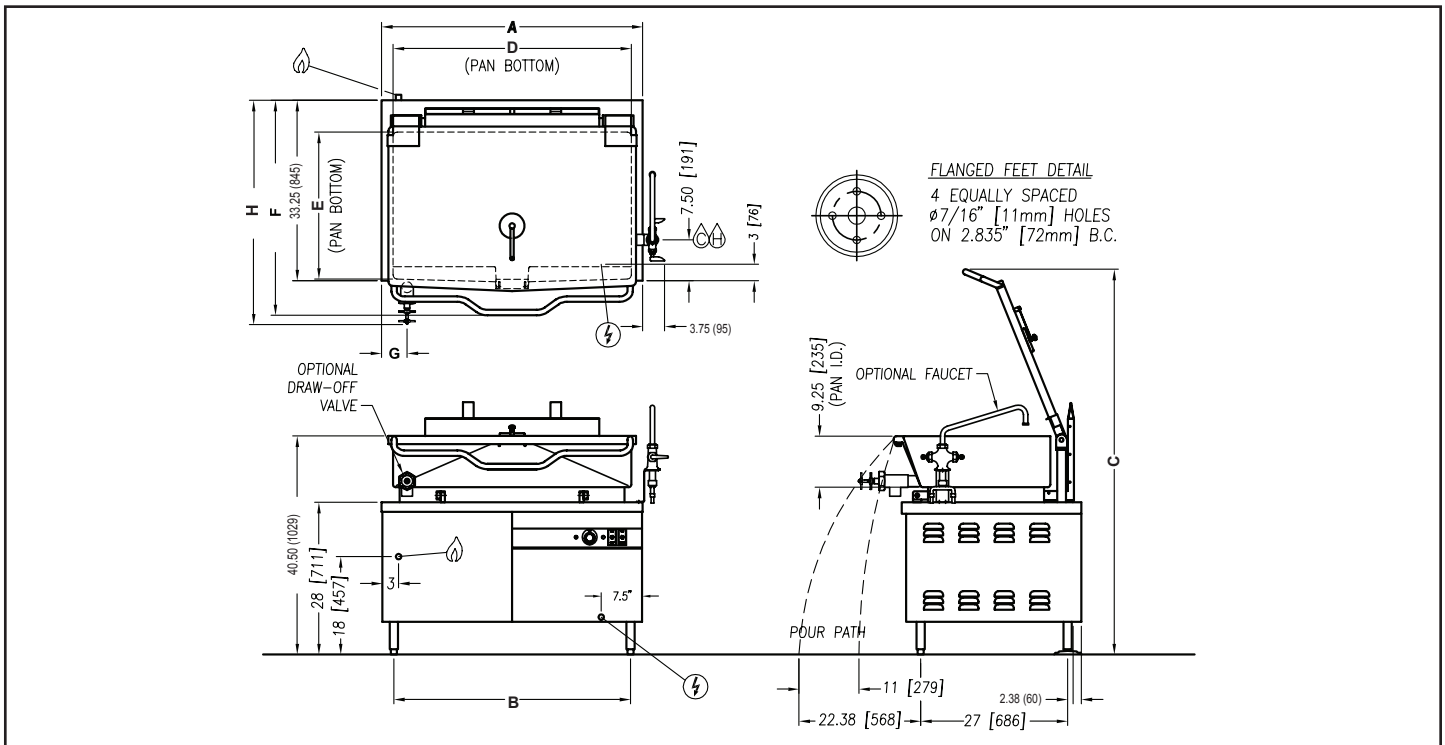

SERVICE CONNECTIONS

- ⚡ _ ELECTRICAL CONNECTIONS: Unless otherwise specified, Field Wire Electrical Connection to be 120 Volts, 60 Hz, single phase with grounding wire. 10 Amp minimum supply.
- 🔥 - GAS CONNECTION: 3/4" IPS. A gas shut-off valve is installed in supply piping.
- Ⓒ - COLD WATER: 3/8" O.D. tubing to faucet (OPTIONAL)
- Ⓓ - HOT WATER: 3/8" O.D. tubing to optional faucet (OPTIONAL)

DIMENSIONS

MODEL	CAPACITY	A	B	C	D	E	F	G	H	
GMTS-30	30 Gallons (114 liters)	36" (914 mm)	30" (762 mm)	72.38" (1838 mm)	33.75" (857 mm)	23.5" (597 mm)	40" (1016 mm)	3.75" (95 mm)	Ø2	Ø3
									42.63" (1083 mm)	46.5" (1181 mm)
GMTS-40	40 Gallons (152 liters)	48" (1219 mm)	42" (1067 mm)	71.75" (1822 mm)	43.75" (1111 mm)	23" (584 mm)	40.38" (1026 mm)	4.75" (121 mm)	42.63" (1083 mm)	46.5" (1181 mm)

GAS CHARACTERISTICS

MODEL	SHIPPING WEIGHT	GAS SUPPLY			MINIMUM CLEARANCE *		
		BTU/HR	kW/HR	Supply Pipe Pressure (W.C.)			
GLTS-30	550 lbs. [249 kg]	80,000	23.4	Natural 6" - 14" (152 mm - 356 mm)	Propane 11" - 14" (279 mm - 356 mm)	Sides	3" (76 mm)
GLTS-40	736 lbs. [334 kg]	100,000	29.3			Back	6" (152 mm)

* For use on non-combustible floors only.

As continued product improvement is a policy of Crown, specifications are subject to change without notice.

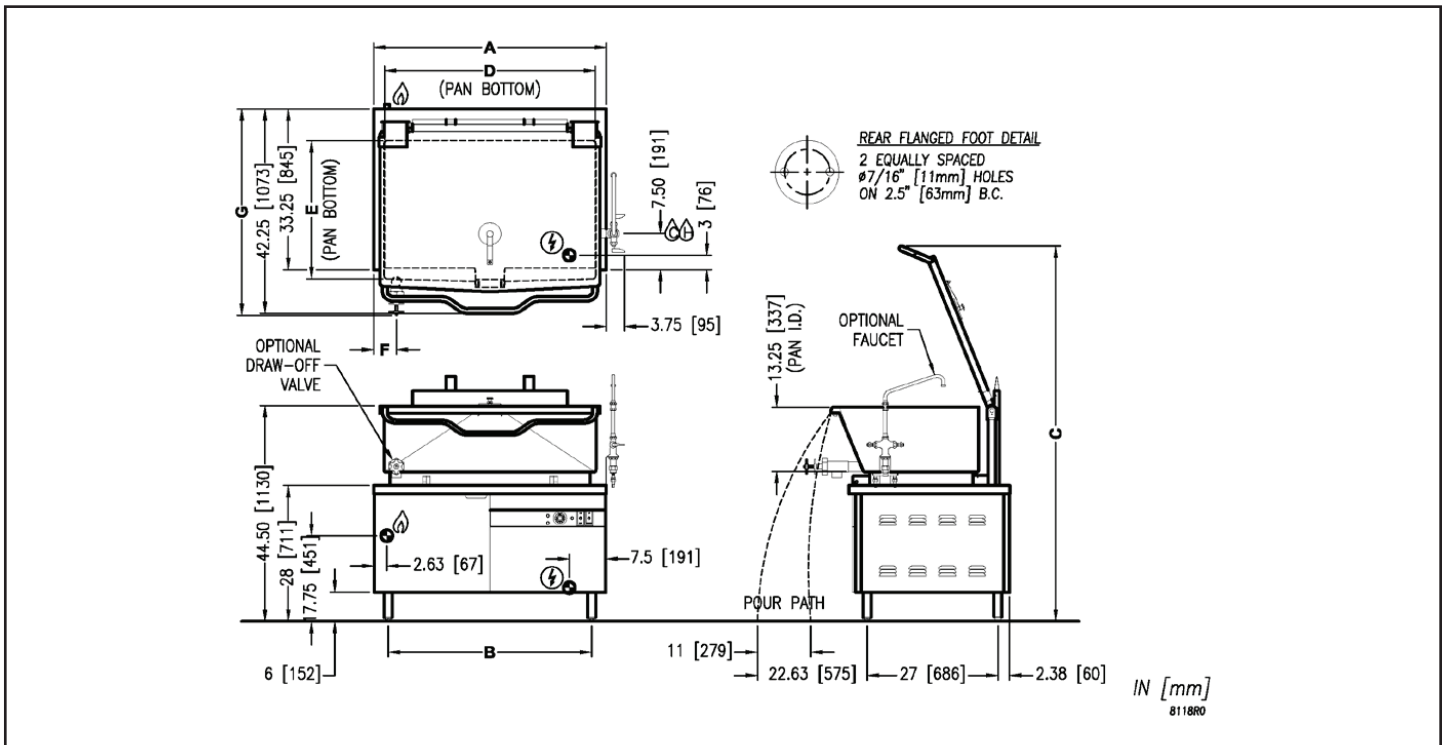

SERVICE CONNECTIONS

- ⚡ - ELECTRICAL CONNECTIONS: Unless otherwise specified, Field Wire Electrical Connection to be 120 Volts, 60 Hz, single phase with grounding wire. 10 Amp minimum supply.
- 🔥 - GAS CONNECTION: 3/4" IPS. A gas shut-off valve is installed in supply piping.
- 🌡️ - COLD WATER: 3/8" O.D. tubing to faucet (OPTIONAL)
- 🌡️ - HOT WATER: 3/8" O.D. tubing to optional faucet (OPTIONAL)

DIMENSIONS

MODEL	CAPACITY	A	B	C	D	E	F	G	
GMTS-60	60 Gallons (227 liters)	48" (1219 mm)	42" (1067 mm)	77.50" (1969 mm)	42.88" (1089 mm)	23" (584 mm)	4.75" (121 mm)	Ø2	Ø3
								42.63" (1083 mm)	46.5" (1181 mm)

GAS CHARACTERISTICS

MODEL	SHIPPING WEIGHT	GAS SUPPLY			MINIMUM CLEARANCE *		
		BTU/HR	kW/HR	Supply Pipe Pressure (W.C)			
GMTS-60	925 lbs. [420 kg]	100,000	29.3	Natural 6" - 14" (152 mm - 356 mm)	Propane 11" - 14" (279 mm - 356 mm)	Side	3"[76 mm]
				Back	6"[152 mm]		

* For use on non-combustible floors only.

As continued product improvement is a policy of Crown, specifications are subject to change without notice.

INSTALLATION INSTRUCTIONS

UNPACKING

IMMEDIATELY INSPECT FOR SHIPPING DAMAGE

Immediately after unpacking the appliance, check for possible shipping damage. If the gas fired tilting skillet is found to be damaged, save the packaging material and contact the carrier within 15 days of delivery.

Prior to installation, verify that the type of gas supply (natural or propane) and electrical service agree with the specifications on the rating plate located on the left side panel as you face the front of the appliance. If the supply and equipment requirements do not agree, contact your dealer immediately.

INSTALLATION CODES AND STANDARDS

Installation must conform with local codes, or in the absence of local codes, with the *National Fuel Gas Code*, *ANSI Z223.1/NFPA 54*, or the *Natural Gas and Propane Installation Code*, *CSA B149.1*, as applicable.

1. The appliance and its individual shut off valve must be disconnected from the gas supply piping system during any pressure testing of that system at pressures in excess of 1/2 psi (3.5 kPa).
2. The appliance must be isolated from the gas supply piping system by closing its individual manual shut off valve during any pressure testing of the gas supply piping system at test pressures equal to or less than 1/2 psi (3.5 kPa).

Electrical grounding must be provided in accordance with local codes, or in the absence of local codes, with the National Electrical Code, ANSI/NFPA 70, or the Canadian Electrical Code, CSA C22.2, as applicable.

Ventilation must be provided in accordance with local codes, or in the absence of local codes, with ANSI/NFPA 96 Standard for Ventilation and Fire Protection of Commercial Cooking Operations.

LOCATION

The installation location must allow adequate clearances for servicing and proper operation.

An exhaust system and ventilation hood should be located directly above the appliance to exhaust combustion gases generated by the unit.

Appliance is intended for use on noncombustible floors. Minimum clearance from combustible and noncombustible floor construction, 3" (76 mm) on sides and 6" (152 mm) from back.

LEVELING AND ANCHORING TILTING BRAISING PAN

1. Place tilting braising pan in the installation position.
2. Place a carpenter's level on top of the braising pan and turn the adjustable feet to level braising pan side-to-side and front-to-back.
3. Mark hole locations on the floor through the anchoring holes provided in the rear flanged adjustable feet.
4. Remove tilting braising pan from installation position and drill holes in locations marked on the floor. (See installation diagram on page 4.) Insert proper anchoring devices (not supplied).
5. Place tilting braising pan back in the installation position.
6. Place carpenter's level on top of braising pan and re-level side-to-side and front to back.
7. Bolt and anchor tilting braising pan securely to the floor.
8. Seal bolts and flanged feet with silastic or equivalent compound.

GAS CONNECTIONS

⚠ WARNING

Do not connect the appliance to the electrical supply until after the gas connection has been made.

⚠ WARNING

Never use an open flame to check for gas leaks. Check all connections for leaks using soapy water before use.

⚠ CAUTION

The pipe thread compound used when installing pipes must be a type that is resistant to the action of liquified petroleum or propane gases.

NOTICE

If this equipment is being installed at over 2,000 feet altitude and was not so specified on order, contact service department. Failure to install with proper orifice sizing may void the warranty.

All gas supply connections and any pipe joint compound used must be resistant to the action of propane gases.

Connect gas supply to the appliance. The gas supply line must be at least equivalent of 3/4" iron pipe with an incoming pressure of 7" - 14" W.C. (Water Column) for natural gas or 11" - 14" W.C. (Water Column) for propane gas. Make sure the pipes are clean and free of obstructions, dirt and piping compound.

Codes require that a gas shutoff valve be installed in the gas line ahead of the tilting braising pan.

Natural gas and propane gas skillets are equipped with fixed orifices and no adjustment is necessary. Gas burner manifold is set at 3.5" W.C. (Water Column) for natural gas, and 10" W.C. (Water Column) for propane gas.

After piping has been checked for leaks, all piping receiving gas should be fully purged to remove air.

ELECTRICAL CONNECTION

⚠ WARNING

Do not connect the appliance to the electrical supply until after the gas connection has been made.

⚠ WARNING**ELECTRICAL GROUNDING INSTRUCTIONS**

This appliance is equipped with a three-prong (grounding) plug for your protection against shock hazard and should be plugged directly into a properly grounded three-prong receptacle. Do not cut or remove the grounding prong from this plug. (120V units only).

The wiring compartment is located behind the control panel. For units operated on electrical supply other than 120 volts, remove the wiring compartment cover and make electrical connections per the wiring diagram located inside the control housing cover panel. The braising pan must be grounded in accordance with requirements of the National Electrical Code or applicable local code.

Replace wiring compartment cover.

OPERATING INSTRUCTIONS

WARNING

The tilting braising pan and its parts are hot. Use care when operating, cleaning and servicing the tilting braising pan.

BEFORE FIRST USE

Using a non-corrosive, grease-dissolving commercial cleaner, clean the protective metal oils from all surface parts and the interior of the tilting braising pan. Follow the cleaner manufacturer's directions. Rinse thoroughly and drain the pan. Wipe dry with a soft clean cloth.

CONTROLS

POWER SWITCH (ON/OFF) Turn ON to supply power to the braising pan burner ignition system.

TILT SWITCH (UP/DOWN) Push up to raise tilting braising pan; push down to lower tilting braising pan.

MOTOR SWITCH Push up to turn power on to the lift motor; push down to turn power off.
Note: It is not necessary to have the power on when using the braising pan. Turn power on only when you intend to operate the tilt feature. This will save energy as well as prevent the motor from overheating.

GREEN IGNITION LIGHT Will light when ignition has occurred.

RED TEMPERATURE LIGHT .. Will light when heating elements are supplying heat to the tilting braising pan.

THERMOSTAT When turned on, will initiate electronic ignition system. Temperature settings range from 1 to 10. (See COOKING GUIDELINES in this manual for temperature ranges for settings 1-10.)

START-UP PROCEDURE

WARNING

In the event of main burner ignition failure, a 5 minute purge period must be observed prior to re-establishing ignition source.

1. Open the manual gas shut-off valve located inside cabinet on left side when facing the front of the unit.
2. Ensure that the skillet pan is in the down or horizontal position.
3. Turn the "POWER" switch "ON".
4. Set the thermostat dial to the desired setting. The red "TEMPERATURE" pilot will be on until the desired setting has been reached.
5. The green "IGNITION" pilot should remain on with the "TEMPERATURE" pilot, indicating normal ignition and operation. If the "IGNITION" pilot goes off while the "TEMPERATURE" pilot remains on, this indicates that the system has failed to ignite the burners. A five minute period of complete shut off is required before restarting;
6. When the skillet has reached the setting, both pilots will go off, indicating the unit has reached the set temperature and that the burners are off. The unit will cycle on and off to maintain the set temperature.
7. Turn the "POWER" switch to "OFF" when the skillet is not in use and close the manual gas shut-off valve.

DAILY SHUTDOWN PROCEDURE

1. To turn tilting braising pan of, turn THERMOSTAT dial to OFF.
2. To turn power to tilt motor OFF, turn power switch to OFF.

TILTING THE BRAISING PAN

1. DO NOT try to tilt braising pan with lid down. Turn MOTOR switch on.
2. Make sure the receiving pan is in place.
3. To tilt braising pan, push and hold TILT SWITCH in the UP mode until desired pan position has been reached. The braising pan will empty when raised to the top tilt position.

When the braising pan is raised 5° or more, the gas supply will be turned off automatically. The braising pan will not operate when the pan is not in the horizontal or down position.

4. Food is poured through the removable strainer (Figure 1) into a food receiving pan positioned under the lip of the pouring spout (Figure 1).
5. To lower braising pan, push and hold TILT SWITCH in the DOWN mode.

When tilting mechanism is not in use, turn MOTOR switch off.

FIGURE 1

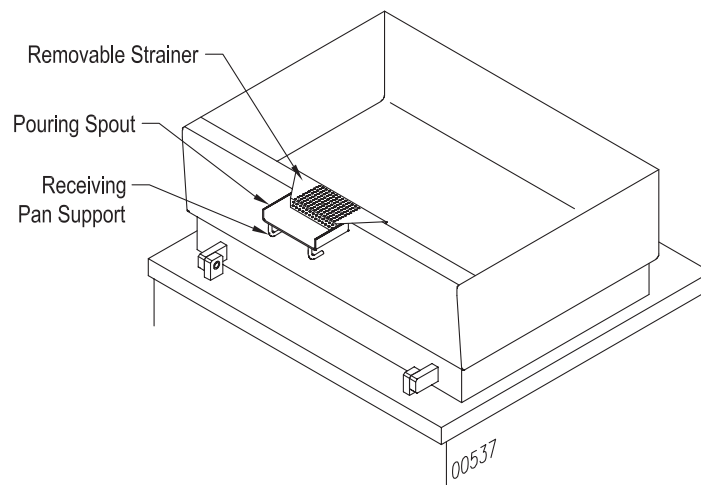

CLEANING

 **WARNING**

Disconnect the power supply to the appliance before cleaning or servicing.

 **WARNING**

The appliance and its parts are hot. Use care when operating, cleaning and servicing the skillet.

 **CAUTION**

Do not use cleaning agents that are corrosive.

After each use, allow the tilting braising pan to cool before cleaning. Keep exposed cleanable areas of the tilting braising pan clean at all times. Do not get water in electrical box or on any electrical component.

1. Thoroughly wash pan, pouring spout, lid and exterior surfaces with mild detergent and warm water. If necessary, soak pan to remove food that is stuck to pan surface. Rinse thoroughly and wipe dry with a soft clean cloth.
2. Clean removable strainer and receiving pan support with mild detergent and warm water. Rinse thoroughly and wipe dry with a soft clean cloth.
3. Clean around burner air mixer and orifice if lint has accumulated.
4. Visually assure carry-over ports are unobstructed.

COOKING GUIDELINES

COOKING METHOD	TEMPERATURE (°F)	THERMOSTAT SETTING
Simmering	200 Maximum	1 - 4
Sautéing	225 - 275	5 - 6
Searing	300 - 350	7 - 8
Frying	325 - 375	8 - 9
Grilling	350 - 450	9 - 10

MAINTENANCE

NOTICE

Contact the factory, factory representative or local service company to perform maintenance and repairs.

WARNING

The tilting braising pan and its parts are hot. Use care when operating, cleaning and servicing the tilting braising pan.

WARNING

Disconnect the power supply to the appliance before cleaning or servicing.

HYDRAULIC SYSTEM

SERVICE

Set up regular schedule for checking the oil temperature, hydraulic hoses and keeping the equipment clean. A thick layer of dirt acts as an insulation and prevents the hydraulic system from getting rid of heat.

The hydraulic system has been adjusted and tested at the factory and no further adjustment should be needed. If the unit fails to operate properly, all service work must be performed by a qualified service agent.

1. Hot oil in the Hydraulic System is one of the primary causes of poor operation. When the tilt system is not in use turn MOTOR switch off.
2. Inspect hydraulic hoses for wear and aging.
3. Check that fluid levels are kept full.
4. To replace oil, fill through filler breather.
5. Use proper oil as specified by factory or equivalent.
6. Check the cleanliness of the oil strainer inside the reservoir once per year. This item can be washed in clean Varsol.
7. Change the breather filter once per year.
8. Change the oil once every two years.

ADJUSTMENTS AND CONTROLS

ADJUST PAN SPEED

There are three controls available on this power unit. The first is an adjustable relief valve mounted into the custom aluminum manifold block. The other two control the linear speed of the actuator.

RELIEF VALVE

The relief valve is located underneath an aluminum hexagon cover on the side of the custom manifold block. This relief valve is factory set to 825 P.S.I. and locked and should not be adjusted.

If adjustments are necessary, remove the hexagon cover which will give access to the relief valve screw. With the pump running, and with a suitable flat blade style screwdriver, rotate the screw clockwise to increase pressure, and anti clockwise to decrease pressure. While this operation is being carried out some oil will leak down the threads of the adjusting screw.

To obtain the pressure required, a pressure gauge will have to be located in the circuit. The best location is on the cylinder hose. To set the pressure, energize the solenoid to extend the cylinder fully and thus "deadhead" the system. The pressure can be set as indicated above. When adjustment is complete, replace the hexagon cover. This will seal the relief valve area. The actual factory set pressure is noted on the label and should not be exceeded as this affects the HP draw on the electric motor.

FLOW CONTROL

! IMPORTANT !

It should be noted that if the cylinder speed is restricted by the flow control valves, the balance of oil not delivered to the cylinder will go over the relief @ 825 P.S.I. which will cause unwanted heat in the reservoir.

There are two flow control valves mounted on the power unit and located on the solenoid valve subplate. The flow control valves will restrict the capacity of oil passing through them when the knurled knob is screwed in - in a clockwise direction. This action will reduce the linear speed of the cylinder. Turning the flow control valve adjustment in the opposite direction - anti clockwise, will increase the speed of the cylinder. One flow control valve (right side) will allow adjustment of the extension speed (travel speed should be set at minimum 20 seconds), the other (left side) the retraction speed. (Retraction speed should be set at minimum 10 seconds).

TROUBLESHOOTING

BURNERS NO NOT COME ON

1. Gas supply to unit is "OFF".
2. Manual shut off valve is "OFF".
3. Thermostat is not turned "ON".
4. Pan not in lowest position.
5. Ignition control not functioning.

BURNERS PRODUCE CARBON DEPOSITS

1. Wrong size orifices.
2. Burner air not adjusted properly.
3. Wrong gas supply.
4. Incorrect pressure at supply.

BRAISING PAN WILL NOT OPERATE (UP OR DOWN)

1. Motor power supply not "ON".
2. Defective UP/DOWN switch.
3. SEE TROUBLESHOOTING - HYDRAULICS.

TROUBLESHOOTING - HYDRAULICS

DIRTY OIL

1. Components not properly cleaned after servicing.
2. Inadequate screening in fill pipe.
3. Air breather left off.
4. Filter dirty or ruptured.

FOAMING OIL

1. Return of tank line not below fluid level.
2. Fluid contamination.
3. Suction leak to pump.

MOISTURE IN OIL

1. Fill pipes left open.
2. Moisture in cans used to replace oil in tank.
3. Extreme temperature differential.

OVERHEATING OF SYSTEM

1. Continuous operation at relief setting.
2. Excessive slippage or internal leakage.
3. Fluid viscosity too high or low.
4. Hose I.D. too small causing high velocity.
5. Improper air circulation around reservoir.
6. System relief valve set too high.
7. Power unit operating in direct sunlight or ambient temperature is too high.

PUMP MAKES EXCESSIVE NOISE

1. Check for vacuum leaks in suction line.
2. Vacuum leak at pump shaft seal.
3. Check alignment with drive mechanism. Misalignment will cause wear and subsequent high noise level operation.
4. Relief valve set too high.
5. Aeration of fluids in reservoir (return line above fluid level.)
6. Worn cam ring, damaged gear, faulty bearing.
7. Reversed rotation.
8. Plugged lines.
9. Oil viscosity too high or temperature too low.
10. Loose or worn pump parts.
11. Pump housing bolts loose or not properly torqued.

SOLENOID VALVES

1. Voltage too low.
2. Short circuit, open connection.
3. Wrong voltage.
4. Foreign matter in fluid causing valves to stick or plug.



HOUGHTON®

SAFETY DATA SHEET

Revision Date 05-04-2018

Version 5

SECTION 1: IDENTIFICATION OF THE SUBSTANCE/MIXTURE AND OF THE COMPANY/UNDERTAKING

Product identifier

Product Code(s)	07122000-M
Product Name	COSMOLUBRIC HF-122
Recommended Use	Fire-resistant hydraulic fluid
Uses advised against	Any other purpose.

Manufacturer, Importer, Supplier

Houghton International Inc.
Madison & Van Buren Aves.
Valley Forge, PA 19482
Telephone: 610-666-4000 FAX: 610-666-1376
Website: www.houghtonintl.com
Customer Service: 888-459-9844

Houghton Canada
915 Meyerside Drive
Mississauga
ON
L5T 1R8

Houghton Mexico S.A. de C.V.
Efraín Gonzalez Luna, 2007 Depto19
Col. Americana, Guadalajara,
Jalisco CP. 44160,
Mexico
Phone: +52-333-615-9331

Emergency telephone number

United States of America/Canada : 3E Company - 1-866-519-4752 (Code 333938)
Mexico : 3E Company - +52 55 41696225 (Code 333938)

SECTION 2: HAZARDS IDENTIFICATION

Classification

This product is not considered hazardous by the 2012 OSHA Hazard Communication Standard (29 CFR 1910.1200) and the Workplace Hazardous Materials Information System (WHMIS) 2015

Not classified

Label elements

The product contains no substances which at their given concentration, are considered to be hazardous to health

Precautionary Statements

Precautionary Statements - Response

Hazards not otherwise classified (HNOC)

Health	Not Applicable.
Physical	Not Applicable.

07122000-M - COSMOLUBRIC HF-122

Revision Date 05-04-2018

Other Information

Not applicable

SECTION 3: COMPOSITION/INFORMATION ON INGREDIENTS

The product contains no substances known to be hazardous to health in concentrations which need to be taken into account.

SECTION 4: FIRST AID MEASURES**Description of first-aid measures**

General advice	If symptoms persist, call a physician.
Inhalation	Move to fresh air.
Skin contact	Wash off immediately with soap and plenty of water. Remove and wash contaminated clothing before re-use.
Eye contact	Rinse thoroughly with plenty of water, also under the eyelids. Keep eye wide open while rinsing.
Ingestion	Clean mouth with water and afterwards drink plenty of water. Do not induce vomiting without medical advice.
Protection of First-aiders	Use personal protective equipment.

Most important symptoms and effects, both acute and delayed

Main Symptoms None

Indication of immediate medical attention and special treatment needed

Notes to physician Treat symptomatically.

SECTION 5: FIRE FIGHTING MEASURES**Extinguishing media****Suitable Extinguishing Media**

Use extinguishing measures that are appropriate to local circumstances and the surrounding environment.; Use CO2, dry chemical, or foam, Water spray or fog

Extinguishing media which shall not be used for safety reasons

None

Special hazards arising from the substance or mixture**Special Hazard**

This material creates a fire hazard because it floats on water.

Hazardous decomposition products

None under normal use

Advice for firefighters**Special protective equipment for fire-fighters**

As in any fire, wear self-contained breathing apparatus pressure-demand, MSHA/NIOSH (approved or equivalent) and full

07122000-M - COSMOLUBRIC HF-122

Revision Date 05-04-2018

protective gear

SECTION 6: ACCIDENTAL RELEASE MEASURES

Personal precautions, protective equipment and emergency procedures

Ensure adequate ventilation.

Advice for non-emergency personnel Material can create slippery conditions.

Advice for emergency responders For personal protection see section 8.

Environmental precautions

Prevent further leakage or spillage if safe to do so. Do not flush into surface water or sanitary sewer system.

Methods and materials for containment and cleaning up

Soak up with inert absorbent material (e.g. sand, silica gel, acid binder, universal binder, sawdust). Dike to collect large liquid spills. After cleaning, flush away traces with water.

Reference to other sections

See Section 8/12/13 for additional information

SECTION 7: HANDLING AND STORAGE

Precautions for safe handling

Ensure adequate ventilation. Use only in area provided with appropriate exhaust ventilation. Handle in accordance with good industrial hygiene and safety practice.

Conditions for safe storage, including any incompatibilities

Technical measures/Storage conditions

Keep container tightly closed in a dry and well-ventilated place. Keep at temperatures between 5 and 40 °C.

Recommended Shelf Life

Shelf life 24 months.

Incompatible materials

Strong oxidizing agents, Strong acids, Strong bases

Specific end uses

Specific use(s) Fire-resistant hydraulic fluid

SECTION 8: EXPOSURE CONTROLS/PERSONAL PROTECTION

Control parameters

Exposure Guidelines

This product does not contain any hazardous materials with occupational exposure limits established by the region specific regulatory bodies.

07122000-M - COSMOLUBRIC HF-122

Revision Date 05-04-2018

Exposure controls

Engineering Measures Showers
 Eyewash stations
 Ventilation systems.

Individual protection measures, such as personal protective equipment

Eye/Face Protection Safety glasses with side-shields.

Skin and body protection Wear protective gloves/clothing.

Respiratory protection No special protective equipment required. In case of mist, spray or aerosol exposure wear suitable personal respiratory protection and protective suit.

Hygiene measures Handle in accordance with good industrial hygiene and safety practice.

SECTION 9: PHYSICAL AND CHEMICAL PROPERTIESInformation on basic physical and chemical properties

Physical state	liquid	Appearance	clear , amber
Odor	bland	Odor threshold	Not Determined

<u>Property</u>	<u>Values</u>	<u>Remarks</u>
pH	Not applicable	
Melting point / freezing point	-33 °C / -27 °F	
Boiling point / boiling range	Not Determined	
Flash point	> 319 °C / > 606 °F	Cleveland Open Cup
Evaporation rate	Not Determined	
Flammability (solid, gas)	Not Determined	
Flammability Limit in Air		
Upper flammability limit:	Not Determined	
Lower flammability limit:	Not Determined	
Vapor pressure	Not Determined	
Vapor density	Not Determined	
Relative density	0.917	g/cm ³ @20°C
Solubility(ies)	Insoluble in water	
Partition coefficient	Not Determined	
Autoignition temperature	Not Determined	
Decomposition temperature	Not Determined	
Kinematic viscosity	>= 49.53 cSt @ 40 °C	ASTM D 445
Explosive properties	Not applicable	
Oxidizing Properties	Not applicable	

Other Information

Viscosity, kinematic (100°C)	Not Determined
Pour Point	-33 °C / -27 °F
VOC Content (ASTM E-1868-10)	Not Determined
VOC content	Not Determined

SECTION 10: STABILITY AND REACTIVITYReactivity

None under normal use conditions

Chemical stability

07122000-M - COSMOLUBRIC HF-122

Revision Date 05-04-2018

Stable under normal conditions

Possibility of hazardous reactions

None under normal use conditions

Conditions to avoid

Keep away from open flames, hot surfaces and sources of ignition

Incompatible materials

Strong oxidizing agents, Strong acids, Strong bases

Hazardous decomposition products

None under normal use conditions

SECTION 11: TOXICOLOGICAL INFORMATION**Information on likely routes of exposure**

Product Information	There is no data available for this product.
Inhalation	Based on available data, the classification criteria are not met
Eye contact	Based on available data, the classification criteria are not met
Skin contact	Based on available data, the classification criteria are not met
Ingestion	Based on available data, the classification criteria are not met
Component Information	Non-hazardous ingredients

Information on toxicological effects

Symptoms No information available.

Delayed and immediate effects as well as chronic effects from short and long-term exposure

Skin corrosion/irritation	Based on available data, the classification criteria are not met.
Serious eye damage/eye irritation	Based on available data, the classification criteria are not met
Sensitization	Based on available data, the classification criteria are not met.
Germ cell mutagenicity	Based on available data, the classification criteria are not met.
Carcinogenicity	Based on available data, the classification criteria are not met.
Reproductive toxicity	Based on available data, the classification criteria are not met.
Specific target organ toxicity (single exposure)	Based on available data, the classification criteria are not met.
Specific target organ toxicity (repeated exposure)	Based on available data, the classification criteria are not met.
Aspiration hazard	Based on available data, the classification criteria are not met.

07122000-M - COSMOLUBRIC HF-122

Revision Date 05-04-2018

SECTION 12: ECOLOGICAL INFORMATIONEcotoxicity

No special environmental measures are necessary

Persistence and degradability No information available.Bioaccumulation No information availableMobility The product is insoluble and floats on water. Is not likely mobile in the environment due its low water solubility.Other adverse effects No information available**SECTION 13: DISPOSAL CONSIDERATIONS**Waste treatment methodsWaste Disposal Methods Dispose of in accordance with federal, state and local regulations.Contaminated packaging Observe all label precautions until container is cleaned, reconditioned or destroyed.**SECTION 14: TRANSPORT INFORMATION**DOT Not RegulatedTDG Not RegulatedMEX Not RegulatedIATA Not RegulatedIMDG Not Regulated**SECTION 15: REGULATORY INFORMATION**International InventoriesInventory information may be utilizing alternative CAS#s or exemptions beyond those stated within this document For further information, please contact: ProductStewardship@houghtonintl.com

TSCA	Complies
DSL	Complies
AICS	Complies
PICCS	Complies
KECL	Complies
IECSC	Complies
ENCS	Does not Comply
TCSI	Complies
NZIoC	Does not Comply

Legend:

07122000-M - COSMOLUBRIC HF-122

Revision Date 05-04-2018

TSCA - United States Toxic Substances Control Act Section 8(b) Inventory
DSL/NDSL - Canadian Domestic Substances List/Non-Domestic Substances List
AICS - Australian Inventory of Chemical Substances
PICCS - Philippines Inventory of Chemicals and Chemical Substances
KECL - Korean Existing and Evaluated Chemical Substances
IECSC - China Inventory of Existing Chemical Substances
ENCS - Japan Existing and New Chemical Substances
TCSI - Taiwan National Existing Chemical Inventory
NZIoC - New Zealand Inventory of Chemicals

U.S. Federal Regulations

SARA 313

Section 313 of Title III of the Superfund Amendments and Reauthorization Act of 1986 (SARA). This product does not contain any chemicals which are subject to the reporting requirements of the Act and Title 40 of the Code of Federal Regulations, Part 372.

SARA 311/312 Hazard Categories

- No EPCRA 311/312 hazards

Clean Water Act

This product does not contain any substances regulated as pollutants pursuant to the Clean Water Act (40 CFR 122.21 and 40 CFR 122.42).

CERCLA

To the best of our knowledge, this product does not contain chemicals at levels which require reporting under this regulation, Comprehensive Environmental Response Compensation and Liability Act (CERCLA) (40 CFR 302) or the Superfund Amendments and Reauthorization Act (SARA) (40 CFR 355). There may be specific reporting requirements at the local, regional, or state level pertaining to releases of this material.

U.S. State Regulations

SCAQMD Rule 1144

This product has not been tested for VOC content by the ASTM E-1868-10 method and is not approved for sale or distribution in the SCAQM District of California if the product is used as a metal forming, metal removal, metal treating, metal protection fluid or as a direct-contact lubricant.

California Proposition 65

This product does not contain any Proposition 65 chemicals.

International Regulations

Ozone-depleting substances (ODS)

Not applicable

Persistent Organic Pollutants

Not applicable

Chemicals Subject to Prior Informed Consent (PIC)

Not applicable

Other Information

Not applicable

SECTION 16: OTHER INFORMATION

07122000-M - COSMOLUBRIC HF-122

Revision Date 05-04-2018

<u>NFPA</u>	Health hazards 0	Flammability 1	Instability 0	Physical and chemical properties -
-------------	------------------	----------------	---------------	------------------------------------

Key or legend to abbreviations and acronyms used in the safety data sheet

STOT SE - Specific target organ systemic toxicity (Single exposure)
STOT RE - Specific target organ systemic toxicity (repeated exposure)
VOC - Volatile organic compounds
NIOSH IDLH: Immediately Dangerous to Life or Health

Revision Date 05-04-2018

Revision Note This SDS has been revised in the following section(s), 2, 3, 8, 11

Disclaimer

The information provided in this Safety Data Sheet is correct to the best of our knowledge, information and belief at the date of its publication. The information given is designed only as a guidance for safe handling, use, processing, storage, transportation, disposal and release and is not to be considered a warranty or quality specification. The information relates only to the specific material designated and may not be valid for such material used in combination with any other materials or in any process, unless specified in the text.

End of Safety Data Sheet

GMTS-30, GMTS-40 & GMTS-60 Gas Skillets



A product with the Crown name incorporates the best in durability and low maintenance. We all recognize, however, that replacement parts and occasional professional service may be necessary to extend the useful life of this appliance. When service is needed, contact a Crown Authorized Service Agency, or your dealer. To avoid confusion, always refer to the model number, serial number, and type of your appliance.



CROWN FOOD SERVICE EQUIPMENT

 A Middleby Company

70 Oakdale Road, Downsview (Toronto) Ontario, Canada, M3N 1V9
Telephone: 919-762-1000 www.crownsteamgroup.com