

Original Instructions Operation Manual

Dual Continuous Feed Toaster
DCFT-BK

Product Identification

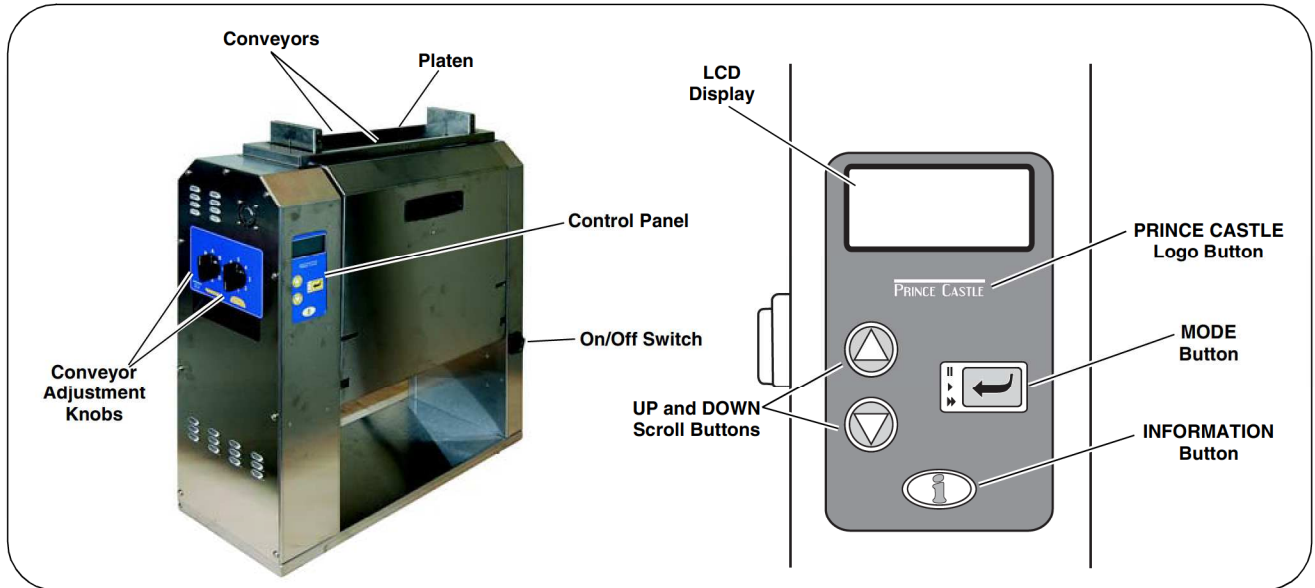

LIMITED WARRANTY

This product is warranted to be free from defects in material and/or workmanship for a period of one (1) year from date of original installation, not to exceed 18 months from date of shipment from our factory. Any part or component which proves to be faulty in material and/or workmanship within the warranty period will be replaced or repaired (at the option of Prince Castle, Inc.) without cost to the customer for parts or labor.

This warranty is subject to the following exceptions/conditions:

- Use of any non-genuine Prince Castle parts voids this warranty and all work must be performed by an authorized Prince Castle Service Agent.
- All labor shall be performed during regular work hours. Overtime premium will not be covered.
- Travel charges are limited to 100 miles (200 kilometers) round trip, 2 hours travel time, one trip per repair.
- Damage caused by carelessness, neglect, and/or abuse (e.g., using wrong current, dropping, tampering with or altering electrical components, or improper cleaning) is not covered.
- Equipment damaged in shipment, by fire, flood or an act of God is not covered.
- Damage to non-stick coated surfaces is not covered by this warranty.

TABLE OF CONTENTS

Product Identification	1
Safety Information	2
General	2
Important	2
Electrical Specifications	2
Installation	2
Operation	4
Management Programming	5
Programming Diagram	7
Daily Planned Maintenance	8
Conveyor Adjustment	10
Troubleshooting	11
Exploded View and Parts List	12
Wiring Diagram	13

PRINCE CASTLE LLC
WORLDWIDE 



A Marmon Group/ Berkshire Hathaway Company

355 East Kehoe Blvd. • Carol Stream, IL 60188 USA
Telephone: 630-462-8800 • Toll Free: 1-800-PCASTLE
Fax: 630-462-1460 • www.princecastle.com



Safety Information

WARNING

Indicates information important to the proper operation of the unit. Failure to observe may result in damage to the equipment and/or severe bodily injury or death.

CAUTION

Indicates information important to the operation of the unit. Failure to observe may result in damage to the equipment.

General

This appliance is designed for toasting bread products in a commercial kitchen. The dimensions of the bread products are defined by customer.

Important

Prince Castle reserves the right to change specifications and product design without notice. Such revisions do not entitle the buyer to corresponding changes, improvements, additions or replacements for previously purchased equipment.

Electrical Specifications

200-240V, 50/60 Hz, 2150-3100W Single Phase

Installation

- 1 Unpack and inspect.** Remove the unit from the carton and inspect for signs of damage. If there is damage to the unit:
 - Notify the carrier within 24 hours of delivery.
 - Save carton and packaging materials for inspection purposes.
 - Contact your local dealer, or if purchased directly, the Prince Castle Sales Department at 1-800-722-7853 or 630-462-8800 to arrange for a replacement unit.

- 2 Verify parts.** Verify that all parts have been received:
 - Dual Continuous Feed Toaster with two conveyors.
 - Release Sheet Kit.
 - Conveyor adjustment tool.

- 3 Place toaster on flat surface.** Remove blue and/or white protective covering.

CAUTION

Two man lift, unit weight >100 lbs (45 kg).

- 4 Remove packing.** Remove the cardboard spacer holding the conveyors up for shipping.

CAUTION

Equipment must be elevated from the floor at all times during cleaning and operation.

- 5 Remove bun infeed by lifting from toaster.**

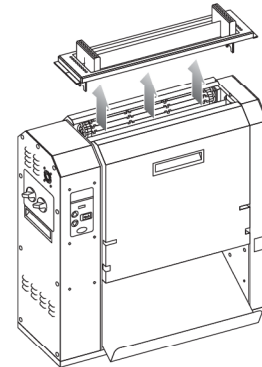

- 6 Open conveyors.** Lift each conveyor up and out. Set conveyors down and remove all packing materials from the conveyors and from the interior of the unit.

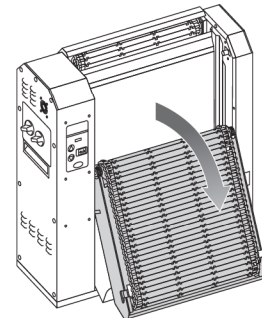

Installation (continued)

7 **Install release sheet.** Place Teflon® release sheet over the platen.

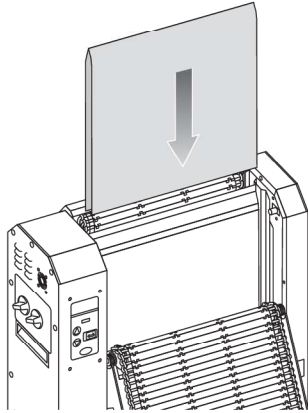

8 **Close conveyors.** Lift one conveyor, lining up its top mounting guides with the top conveyor mounting pins on the unit. Slide the conveyor in and down until it is securely in place. Repeat with the other conveyor.

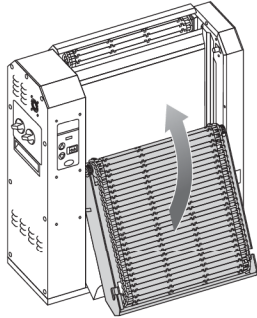

9 **Plug unit in.** Plug unit into a grounded receptacle with a matching plug configuration.

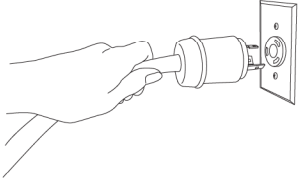

WARNING

All electrical connections must be in accordance with local electrical codes and any other applicable codes.

This appliance can be used by children aged from 8 years and above and persons with reduced physical, sensory or mental capabilities or lack of experience and knowledge if they have been given supervision or instruction concerning use of the appliance in a safe way and understand the hazards involved. Children shall not play with the appliance.

Operation

- 1 Turn unit ON.** Turn the On/Off switch located opposite the display panel to ON. The Prince Castle DCFT screen will appear in the LCD display for 3 seconds.

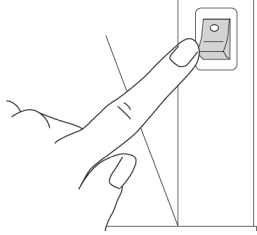

- 2 Wait through Warm-Up.** During warm-up, the LCD display will read "STATUS" and "WARMING...". Warm-Up time is about 10-15 minutes.

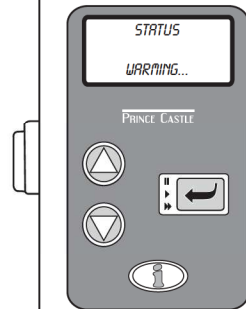

- 3**  **WARNING**
BURN/ELECTRICAL SHOCK HAZARD! Platen sections are **HOT** and can cause severe burns or severe shock. Keep hands and objects out of the toaster unit! Failure to exercise caution may result in serious injury! Turn the unit off, unplug it and let it cool down completely before touching or working on internal apparatus.

Watch for READY status. When ready temperature is reached, the LCD display will read "STATUS" and "READY".

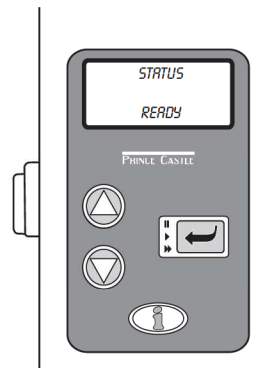

- 4 Observe conveyor.** Conveyors have been adjusted at the factory. However, if their motion appears jerky or you hear a "skipping" sound, the gears may have been disturbed. See *Conveyor Adjustment* for details.

- 5 View temperature, if desired.** Pressing the INFORMATION button once will display the platen actual temperature. Pressing a second time will return the LCD display to the READY screen.

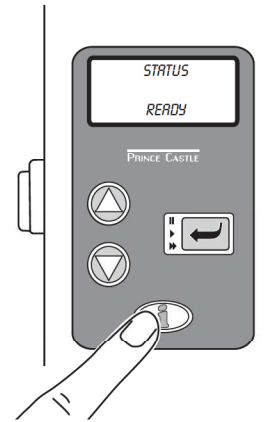

- 6 Choose the conveyor adjustments.** Dial the two front conveyor adjustment knobs for the product part (Regular Crown, etc.) that you will be toasting in the front of the unit. Dial the two rear conveyor adjustment knobs for the product part (Regular Heel, etc.) that you will be toasting in the rear of the unit.

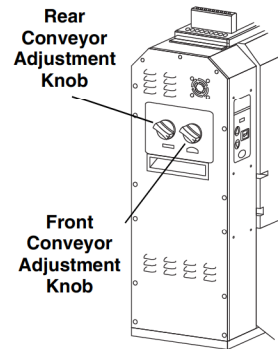

- 7 Begin continuous feeding.** Feed product into top of DCFT, sending the correct product parts down the front and rear of the unit. The sides to be toasted should face the platen. Toasted product will exit at the base of the DCFT.

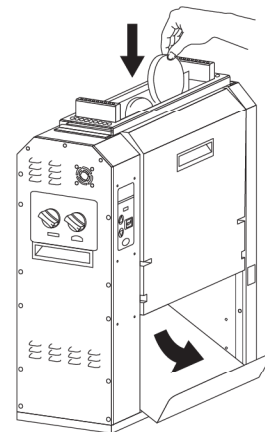

Management Programming

1

Enter program screens. Press and hold the PRINCE CASTLE logo button for 6 seconds. The PROGRAMMING VERSION screen will appear in the LCD display for 10 seconds. From the PROGRAMMING VERSION screen, you may:

- A. Press the DOWN scroll button once to choose Fahrenheit or Celsius.
- B. Press the DOWN scroll button twice to adjust temperature.
- C. Press the DOWN scroll button three times to change language.
- D. Press the PRINCE CASTLE logo button or leave the controls inactive for 10 seconds to exit programming.

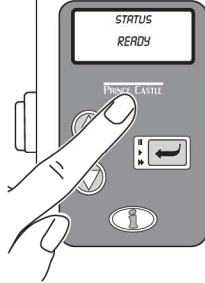

2

Choose Toast Time. From the PROGRAMMING VERSION screen, press the DOWN scroll button once. From the TOAST TIME screen that appears, press the MODE button.

- A. From the TOAST TIME screen that appears, use the UP and DOWN scroll buttons to select TIME.

- B. Accept the new time by pressing the MODE button to return to the TOAST TIME screen.
NOTE: To return without accepting the new setting, press the PRINCE CASTLE logo button.

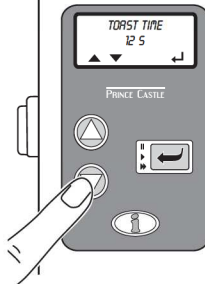
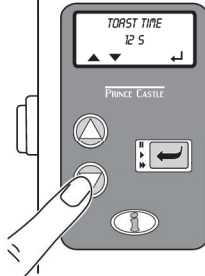
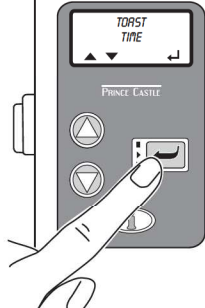

3

Choose Fahrenheit or Celsius. From the PROGRAMMING VERSION screen, press the DOWN scroll button once. From the SELECT F/C screen that appears, press the MODE button.

- A. From the SET F/C screen that appears, use the UP and DOWN scroll buttons to select TEMP = F (Fahrenheit) or TEMP = C (Celsius).

- B. Accept the new scale by pressing the MODE button to return to the SELECT F/C screen.
NOTE: To return without accepting the new setting, press the PRINCE CASTLE logo button.

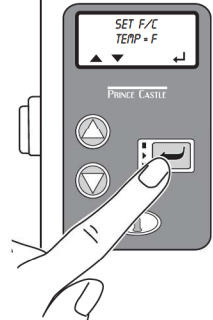
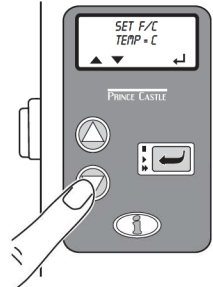
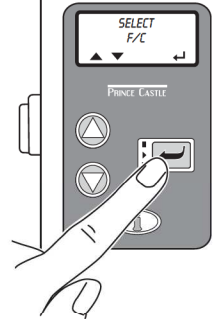

Management Programming (continued)

4 Adjust set point temperature. From the SELECT F/C screen, press the DOWN scroll button. From the SELECT PLATEN TEMPERATURE screen, press the mode button.

A. From the SET PLATEN screen that appears, adjust the platen set point temperature using the UP and DOWN scroll buttons.

B. Accept the new platen setting by pressing the MODE button to return to the SELECT PLATEN TEMPERATURE screen. *NOTE: To return without accepting the new setting, press the PRINCE CASTLE logo button.*

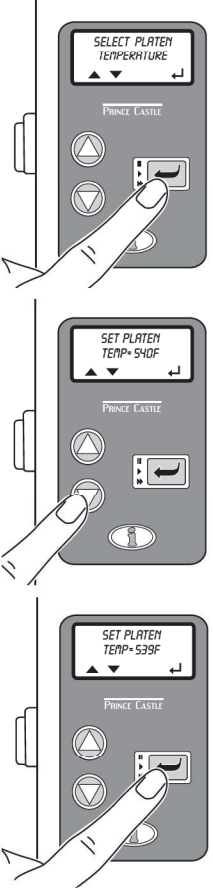

5 Change language. From the SELECT PLATEN TEMPERATURE screen, press the DOWN scroll button. From the SELECT LANGUAGE screen, press the MODE button.

A. From the LANGUAGE screen that appears, use the UP and DOWN scroll buttons to select a different language.

B. Accept the new language by pressing the MODE button to return to the SELECT LANGUAGE screen. *NOTE: To return without accepting the new setting, press the PRINCE CASTLE logo button.*

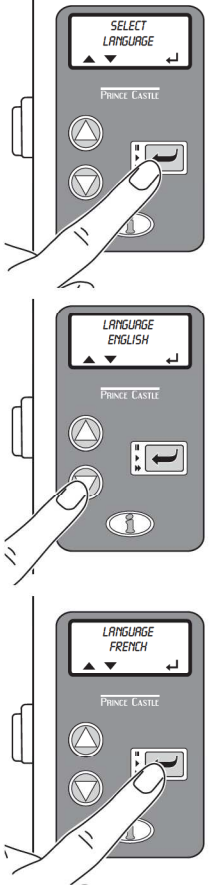

6 Exit programming. Press the PRINCE CASTLE logo button from the SELECT F/C, SELECT PLATEN TEMPERATURE or SELECT LANGUAGE screen or leave the controls inactive for 10 seconds.

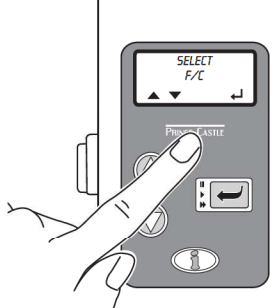

Temperature	Factory Presets	New Setting
Platen	540°F/283°C	
Toast Time	12 sec.	

Programming Diagram

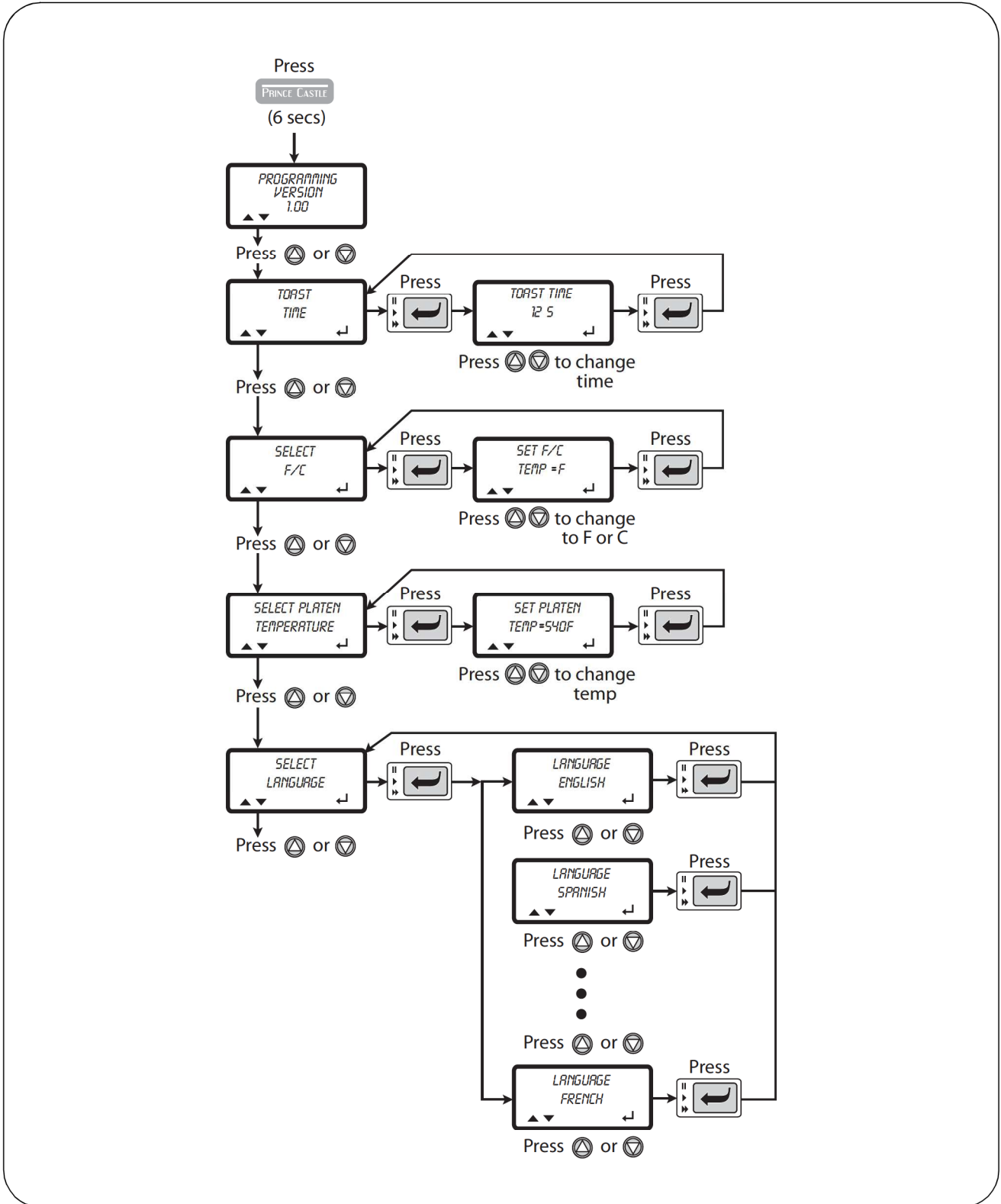

Daily Planned Maintenance

WARNING

BURN/ELECTRICAL SHOCK HAZARD! Platen sections are HOT and can cause severe burns or severe shock. Keep hands and objects out of the toaster unit! Failure to exercise caution may result in serious injury! Turn the unit off, unplug it and let it cool down completely before touching or working on internal apparatus.

WARNING

If the supply cord is damaged, it must be replaced by the manufacturer, its service agent, or similarly qualified person to avoid a hazard.

CAUTION

Do not immerse toaster in water. Do not clean with a water hose or jet spray. Do not use abrasive cleaners, pads or tools on the platen or the release sheet. Failure to exercise caution will result in damage to the unit and will not be covered by warranty. Cleaning and user maintenance shall not be made by children without supervision.

- 1 Gather cleaning materials.** You will need a clean, damp cloth, soft bristle brush, neoprene gloves, lukewarm soap and water, and non-abrasive cleaner.

- 2 Turn DCFT OFF.** Turn the On/Off switch located opposite the display panel to OFF.

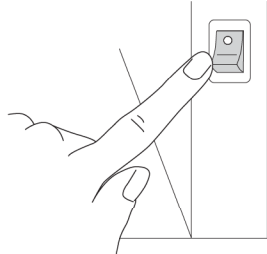

- 3 Unplug and let cool.** Allow platen to cool for 60 minutes before cleaning. The plug removed from the outlet shall remain clearly visible to the operator during the maintenance procedure.

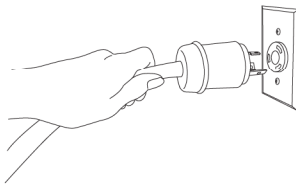

- 4 Open conveyors.** Lift each conveyor up, out and set down in open position.

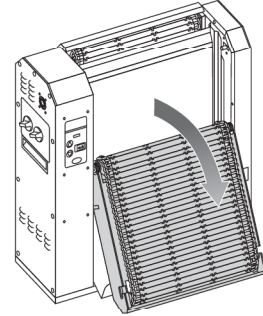

- 5 Remove the release sheet.** Lay the release sheet on a flat surface.

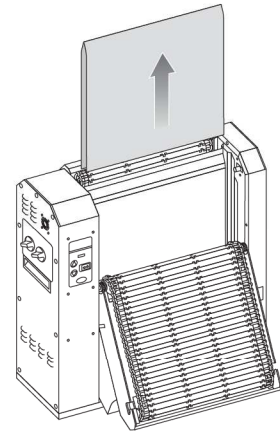

- 6 Clean the conveyors.** Put on neoprene gloves. Wipe the conveyors with a damp cloth. Use a soft bristle brush as necessary.

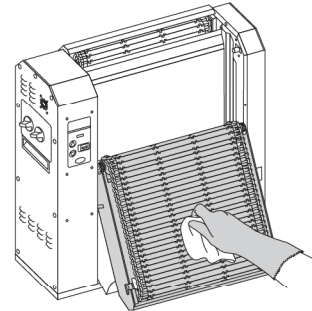

Daily Planned Maintenance (continued)

7 Clean the release sheet. Dampen a clean cloth with lukewarm soap and water. Wipe down both sides of the release sheet, making sure all built-up sugar is removed. Allow to air dry. *NOTE: Rotate sheets daily for longer life. Depending on volume of product toasted, sheets should be replaced every 4 to 6 weeks.*

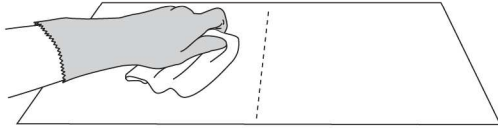

8 Clean the platen surface. Use a damp cloth to remove any built-up sugar on the surface.

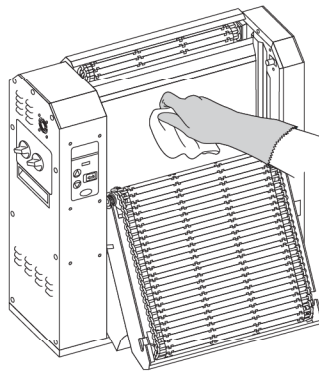

9 Clean outside of the DCFT. Dampen a clean cloth with lukewarm soap and water. Wipe down the outside of the entire DCFT. Wipe down the entire DCFT again with a fresh clean, sanitized towel.

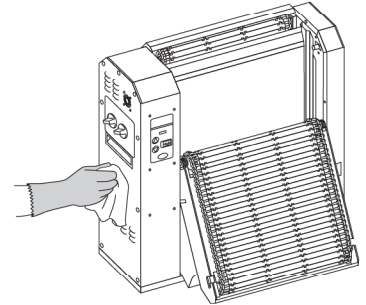

10 Reassemble the unit.

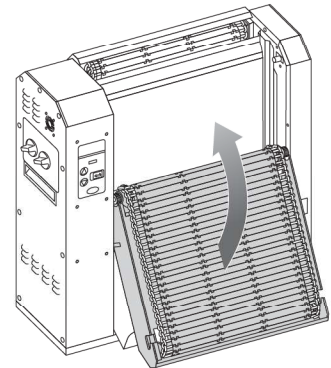

Conveyor Adjustment

1 Use a 3/8" open end wrench.

2 Turn DCFT OFF.
Turn the On/Off switch located opposite the display panel to OFF.

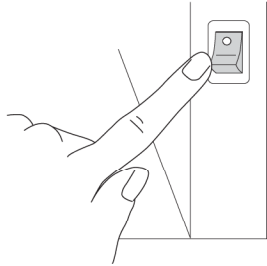

3 To lower conveyor, turn wrench to the left as shown.

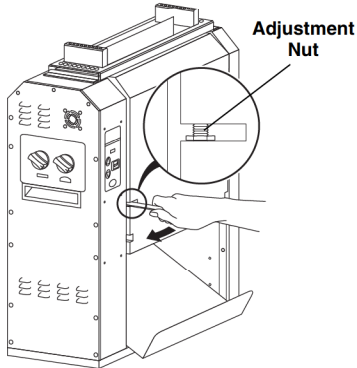

4 To raise conveyor, turn wrench to the right as shown.

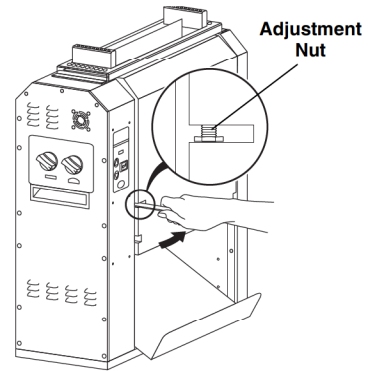

5 Repeat adjustment for opposite conveyor.

6 Turn DCFT ON and observe.

#526-710S - Wide Gear Set
#525-161S Drive Train

Troubleshooting

 **WARNING**

BURN/ELECTRICAL SHOCK HAZARD! Platen is HOT and can cause severe burns or severe shock. Keep hands and objects out of the toaster unit! Failure to exercise caution may result in serious injury! Turn the unit off, unplug it and let it cool down completely before touching or working on internal apparatus. The plug removed from the outlet shall remain clearly visible to the operator during the maintenance procedure.

PROBLEM	POSSIBLE CAUSE	SOLUTION
Unit has no power	Unit unplugged	Plug unit in.
	Breaker tripped	Reset breaker.
	High limit	Call for service (888-375-2938).
	Loose connection on power switch	Call for service (888-375-2938).
	Inoperable power switch	Call for service (888-375-2938).
Unit will not heat up	Loose connection on platen	Call for service (888-375-2938).
	Open platen	Call for service (888-375-2938).
	Loose connection to the main control board	Call for service (888-375-2938).
	Inoperable main control board	Call for service (888-375-2938).
	Inoperable SS Relay	Call for service (888-375-2938).
Unit heats up, but the conveyor does not run	Inoperable motor	Call for service (888-375-2938).
	Stripped drive gear	Call for service (888-375-2938).
	Stripped conveyor gear	Call for service (888-375-2938).
	Jammed conveyor assembly	Call for service (888-375-2938).
	Conveyor assembly out of alignment	Adjust conveyor (see <i>Conveyor Adjustment</i> section).
	Inoperable drive train	Call for service (888-375-2938).
Not toasting properly (under- or over-done)	Inoperable t-probe	Call for service (888-375-2938).
	Improper set point	Adjust set point in programming (see <i>Management Programming</i> section).
	Improper compression	Adjust compression (see <i>Operation</i> section).
	Torn or soiled release sheet	Clean or replace release sheet.
	Bad platen	Call for service (888-375-2938).
Conveyor appears jerky or pops out when toasting	Conveyor assembly out of alignment	Adjust conveyor (see <i>Conveyor Adjustment</i> section).
Jumpy display	Improper ground	Call for service (888-375-2938).
Blank display	Inoperable display	Call for service (888-375-2938).
	Inoperable main control board	Call for service (888-375-2938).
	Loose wiring harness	Call for service (888-375-2938).

Exploded View and Parts List

With the exception of maintenance items, such as Teflon sheets, electrical and mechanical parts should be replaced only by a qualified service representative.

No.	Part No.	Description
1	526-073S	Membrane Switch w/Overlay
2	526-021S	Display Board
3	525-106S	Main Board
4	85-144-24S	Power Supply Board
5	526-025S	Motor
6	526-023S	Fan (qty of 2)
7	526-032S	Handle (qty of 2)
8	78-233S	Power Switch
9	526-627S	Platen
10	65-058S	SS Relay 50A
11	65-064S	Power Relay
12	77-090S	Terminal Block
13	525-022S	Conveyor, Crown
14	526-295S	Gear (qty of 2)

No.	Part No.	Description
15	526-391S	Hi Limit
16	72-446S	Power Cord
17	526-221S	Knobs (qty of 2)
18	525-004S	Teflon Sheet
19	77-092-03S	Terminal Block
20	526-185S	Minor Side Overlay
21	526-022S	Probe
22	526-184S	Major Side Overlay
23	525-024S	Conveyor, Heel
24	526-289S	Drive Train Assembly
25	525-138S	Drive Chain
26	86-558S	Tensioner Spring
27	526-101S	Tensioner Assembly

gear set screw 197-295S

#526-710S - Wide Gear Set
#525-161S Drive Train

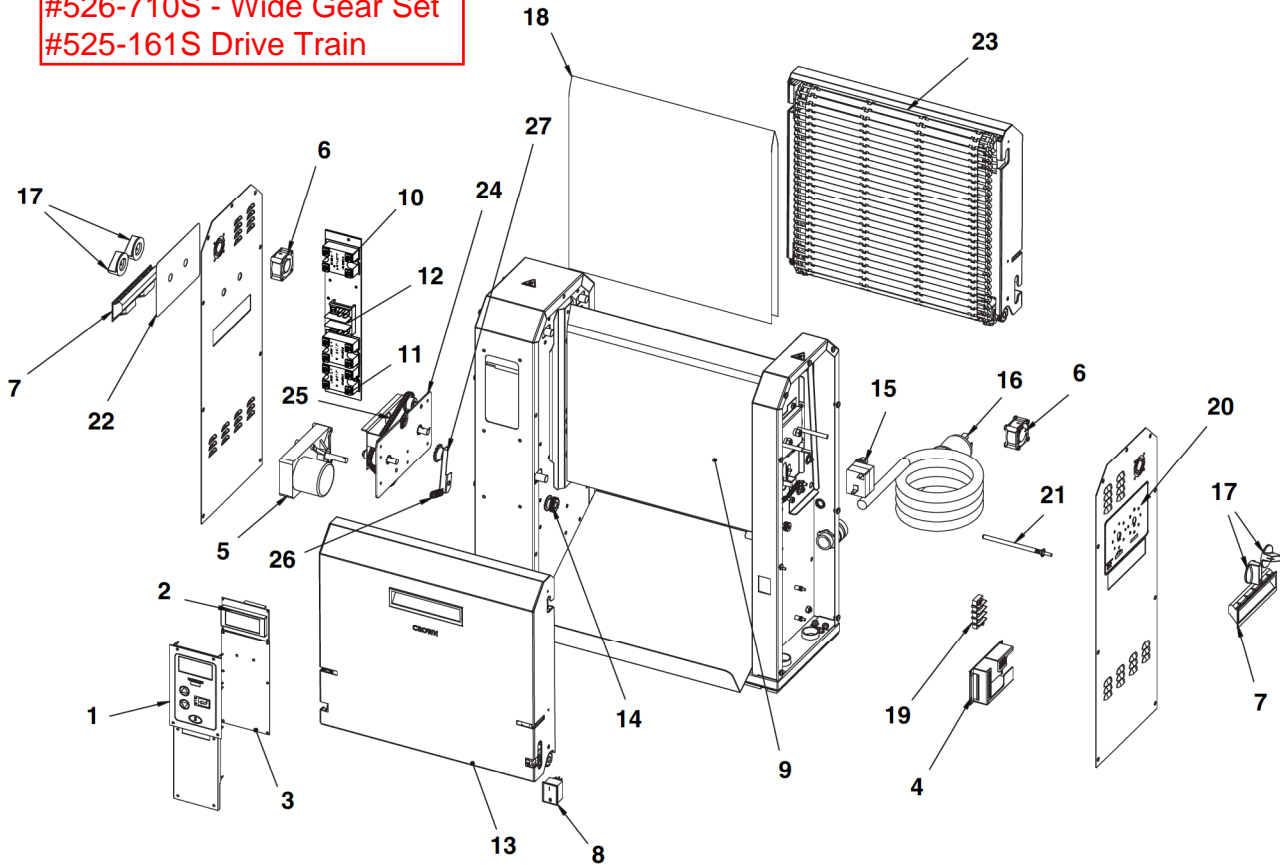

Wiring Diagram

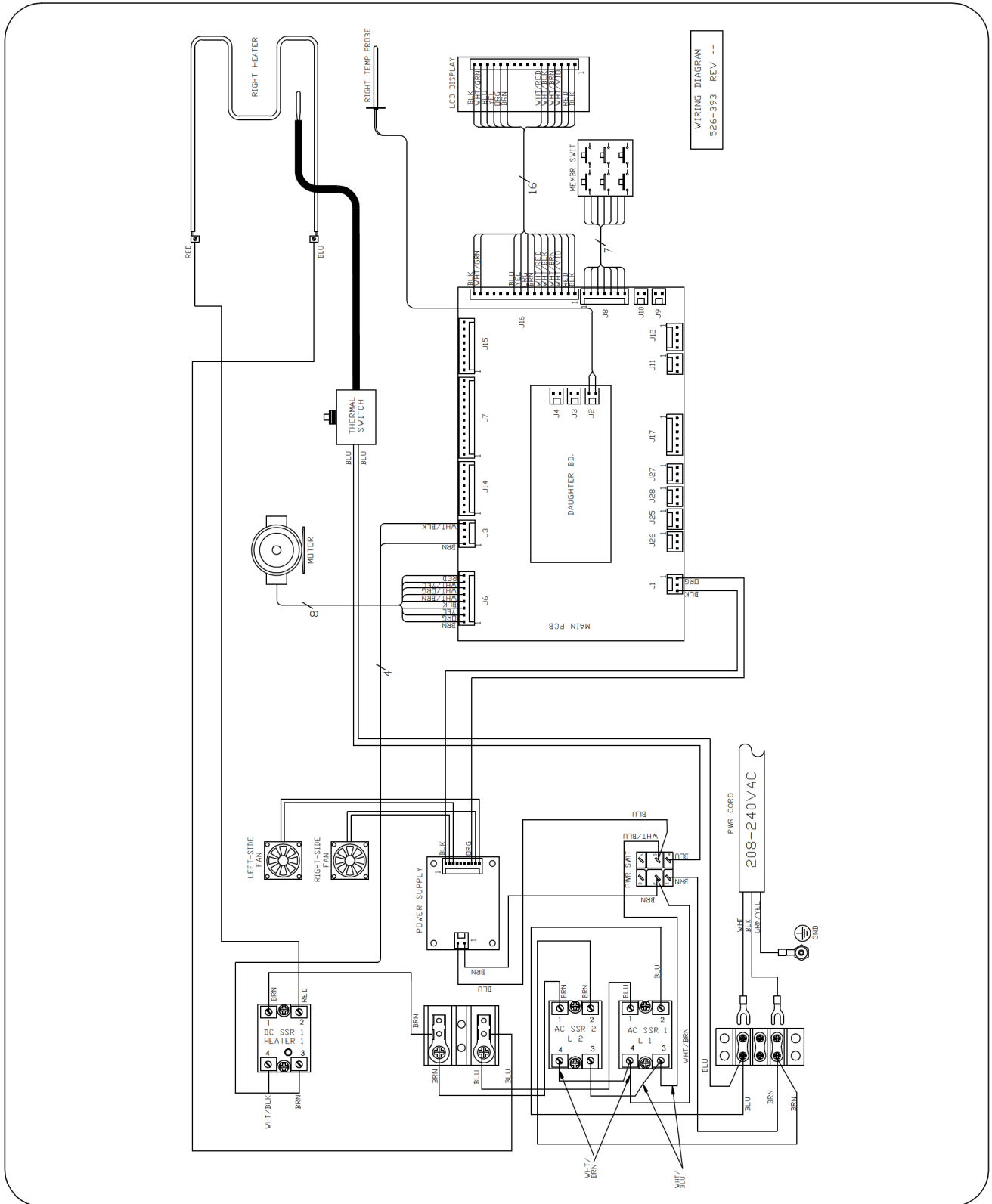

WIRING DIAGRAM
526-993 REV --