

Original operating instructions **ditting**[®]
— SWISS —

PEAK Single Espresso Grinder

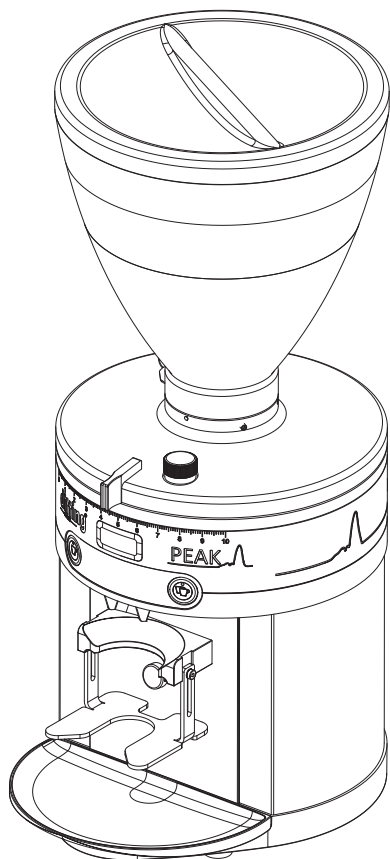

Overview

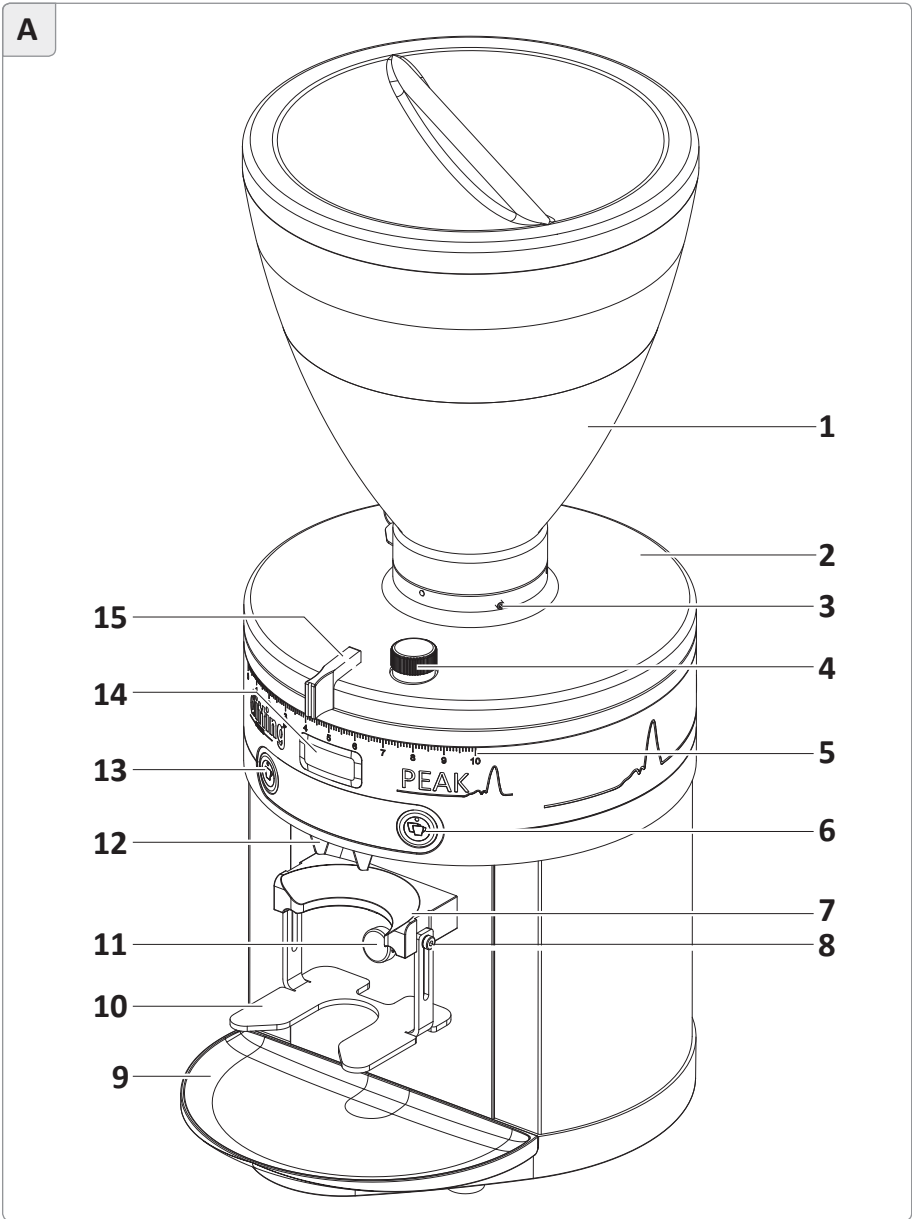

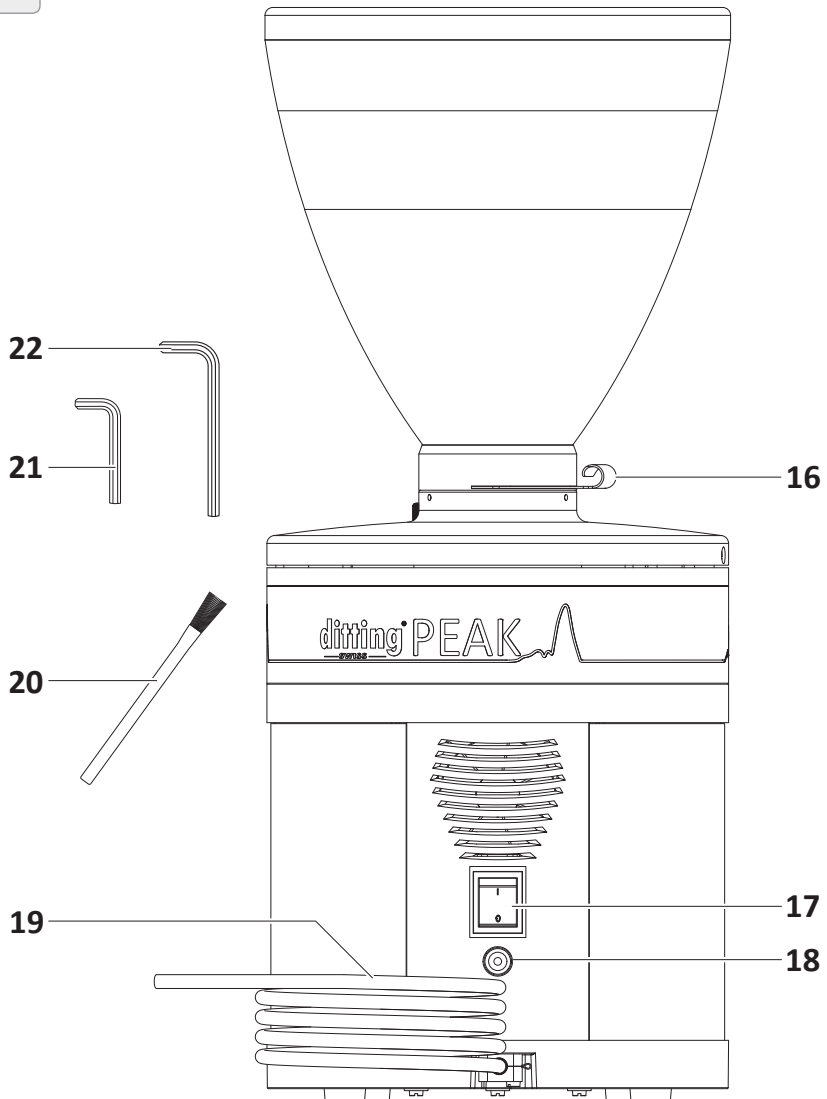
B

PEAK Single Espresso Grinder

Contents

Overview	2	Settings	18
Delivery contents	5	Show counter	19
General information	6	Setting the light.....	20
Reading and keeping the operating instructions.....	6	Setting the temperature display ...	21
Explanation of the symbols used.....	6	Setting the alarm.....	21
Safety	8	Setting the ventilation.....	22
Proper use.....	8	Setting the break function	22
Safety instructions	8	Cleaning	22
Before initial use	11	Cleaning the area where the grinder is positioned.....	23
Checking the grinder and delivery contents	11	Cleaning the housing	23
Assembly and basic settings	11	Cleaning the hopper	23
Operation	12	Cleaning the burr	24
Putting the grinder into operation and selecting the mode	12	Troubleshooting	25
Setting the grind	14	Technical data	29
Display/navigation symbols	14	Disposal	30
Setting grinding time.....	15	Disposal of packaging	30
Grinding espresso beans	16	Disposal of grinder.....	30
Interrupting grinding (break function)	17	Service	30
Changing the type of espresso beans	17	CE Declaration of Conformity	31
		Complaint report	33

Delivery contents

No. Designation

- 1 Hopper (with lid)
- 2 Grind lid
- 3 Locking screw for hopper
- 4 Unlocking screw for grind adjustment
- 5 Grind scale
- 6 "Double Shot" selection button
- 7 Portafilter holder
- 8 Screw for adjustment of the portafilter fork (left and right), 2x
- 9 Drip tray
- 10 Portafilter fork
- 11 Start button
- 12 Adjustable spout
- 13 "Single Shot" selection button
- 14 Display
- 15 Locking slide
- 16 Hopper slide
- 17 On/off switch
- 18 Release button/Thermal overcurrent circuit-breaker
- 19 Power cable
- 20 Brush
- 21 Allen key (short, 3 mm)
- 22 Allen key (long, 2 mm)

General information

Reading and keeping the operating instructions



Before you start using the PEAK Single Espresso Grinder, please read through these original operating instructions and safety instructions carefully. Only then will you be able to operate and use the PEAK Single Espresso Grinder safely. The original operating instructions are based on the standards and rules that apply in the European Union. If you are outside the EU, please also observe any national guidelines and legislation.

In the interests of comprehensibility, the PEAK Single Espresso Grinder will be referred to subsequently simply as the “grinder”.

Keep these original operating instructions in case you have any questions at a later date. Also pass these original operating instructions on to subsequent owners and users of the grinder.

Explanation of the symbols used

The following symbols and signal words are used in these original operating instructions, on the grinder and on the packaging.



WARNING!

This signal word/symbol indicates a hazard with a moderate degree of risk which, if not avoided, can lead to serious injury or death.



CAUTION!

This signal word/symbol indicates a hazard with a low degree of risk which, if not avoided, can lead to minor or moderate injury.

NOTICE!

This signal word warns of potential material damage.



This symbol indicates useful tips on operating or handling the grinder.



Declaration of Conformity (see the section “Declaration of Conformity”):

Products marked with this symbol meet all of the applicable Community regulations of the European Economic Area.



Products marked with this symbol may only be used indoors.



This symbol indicates that you must disconnect the power plug before cleaning or repairing the machine.



This symbol indicates that there is a risk of electric shock.



This symbol indicates that the grinder meets Protection class I.



This symbol indicates that the grinder is in Single Shot mode.



This symbol indicates useful tips on operating or handling the grinder.



This symbol indicates that the grinder is in Barista mode.



This product has met the United States of America electrical product safety requirements and has earned the ETL Listed Mark.

This grinder’s ETL control number is: 3097279.

3097279

Safety

Proper use

The grinder is suitable for grinding whole roasted espresso beans only. Do not use the grinder for grinding other products or objects. It is intended for commercial use and may only be serviced by trained personnel, although it may be operated by other persons at a location where its use is supervised. Any other use is deemed to be improper and can lead to material damage or even physical injury. Do not make any modifications to the grinder. Neither the manufacturer nor the dealer can accept liability for failure to comply with the safety instructions.

Safety instructions

WARNING!

Risk of electric shock!

Improper use, defective electrical installation or line voltage that is too high can lead to an electric shock.

- Only connect the grinder if the line voltage of the socket matches the specifications on the rating plate.
- Connect the grinder to an easily accessible socket so that you can disconnect it from the grid quickly in the event of a fault.
- Do not operate the grinder if it has obvious signs of damage or the power cable or plug is defective.
- If the power cable of the grinder is damaged, it must be replaced by the manufacturer or an electrician to avoid any risks.
- Connect the grinder to a power supply with a 16 A-slow fuse only. Arrange for a qualified electrician to install a 16 A-slow fuse if the power supply at the installation location for the grinder is not protected in this way.
- Install the grinder only at locations at which its use can be supervised by trained personnel.
- Do not immerse the grinder, the power cable or the plug in water or any other liquid.
- Never touch the plug with wet hands.

- Never pull the plug from the socket by the power cable, always hold the plug itself.
- Never use the power cable as a carrying handle.
- Keep the grinder, the power cable and the plug away from open flames and hot surfaces.
- Do not install the cable in such a way that it causes a risk of tripping.
- Do not kink the power cable and do not lay it over sharp edges.
- Use the grinder indoors only. Never operate the grinder in wet areas or in the rain.
- Keep the grinder out of the reach of children.
- Ensure that children do not insert objects into the grinder.
- If you are not using or cleaning the grinder or if a fault occurs, switch the grinder off and pull the plug out of the socket.
- Do not open the housing; leave repairs to a specialist. Consult a specialist repair workshop. Liability and warranty claims will be invalidated if you carry out repairs yourself, connect the grinder incorrectly or use it improperly. Only parts that meet the original machine specifications may be used for repairs. There are electrical and mechanical parts in this grinder that are essential for protection against hazards.

 **WARNING!**

Danger to children and persons with limited physical, sensory or mental capacities (the partially disabled, for example, or elderly people with restrictions to their physical and mental capacities) or a lack of experience and knowledge (older children, for example).

- This grinder may be used by children over the age of eight and persons with limited physical, sensory or mental capacities or a lack of experience and knowledge if they are supervised or have been instructed in using the grinder safely and understand the resulting dangers. Children may not be allowed to play with the grinder. Cleaning and user maintenance may not be carried out by children without supervision.

- Do not leave the grinder unattended during operation.
 - Do not allow children to play with the packaging film. Children can become entangled when playing with it and suffocate as a result.
 - Do not allow children to play with the small parts. They may be fatal if swallowed.
-

 **CAUTION!**

Risk of tipping and injury!

Improper handling of the grinder can lead to injuries.

- Install the power cable in such a way that no one can become entangled in it and the grinder cannot fall as a result.
 - Place the grinder on an even, firm surface so that it cannot fall.
-

Before initial use

Checking the grinder and delivery contents

NOTICE!

Risk of damage!

If you open the packaging without due care with a sharp knife or other pointed object, the grinder may be damaged.

- Proceed very carefully when opening the packaging.
-

1. Take the grinder out of the packaging.
2. Check that all items have been supplied (see **Fig. A** and **B**).
3. Check the grinder and individual parts for damage. If there is any damage, do not use the grinder. Consult your dealer at the address given in the “Service” section.

Assembly and basic settings

Set up the grinder and insert the hopper

1. Place the grinder on an even, firm and vibration-free surface.
2. Ensure that the adjustable spout (**12**) is pulled forward until it stops.
3. Insert the plug into a correctly installed socket.
4. Ensure that the rubber ring is in the hole in the grind lid (**2**).
5. Place the hopper (**1**) over the hole in the grind lid.
When positioning the hopper, ensure that the circular recess behind the locking screw for the hopper (**3**) is positioned in the grind lid.
6. Press the hopper gently downwards and simultaneously rotate the hopper clockwise until it locks in place.
7. Screw the locking screw for the hopper firmly in place using the Allen key (long, 2 mm) (**22**).

Adjusting the portafilter fork

Set the portafilter fork **(10)** to the size of the portafilter on your espresso machine:

1. Ensure that the grinder is switched off and is not connected to the power grid.
2. Using the Allen key (short, 3 mm) **(21)**, release the screws for the portafilter fork (left and right) **(8)** by turning them anti-clockwise. The portafilter fork lowers until it reaches the stop.
3. Place the portafilter in the portafilter holder **(7)**.
4. Push the portafilter fork upwards until the portafilter fits exactly between the portafilter fork and the portafilter holder.



If the portafilter fork supplied does not fit, consult your dealer at the address given in the “Service” section.

5. Hold the portafilter fork in position and fix it in place with the screws for the portafilter fork (left and right) by turning them clockwise with the Allen key (short, 3 mm).
6. Adjust the spout **(12)** to your portafilter by pushing it back or pulling it forward so that the ground espresso beans fall into the center of your portafilter.



Reset the spout every time you adjust the grind and every time you change the type of espresso beans.

Operation

Putting the grinder into operation and selecting the mode

- Switch the grinder on by pressing the on/off switch **(17)** on the back of the grinder.



The automatic fan function is set in the factory. The fan switches on automatically at a grinder temperature of 86 °F (30 °C) and off again automatically at a grinder temperature of 82.4 °F (28 °C).

The grinder is ready for operation as soon as the mode set appears on the display **(14)**.

- To select Single Shot mode, press and release the “Single Shot” selection button **(13)**.
- To select Double Shot mode, press and release the “Double Shot” selection button **(6)**.
- To select Barista mode, press and release the two selection buttons **(13)** and **(6)** simultaneously.

NOTICE!

Risk of overheating!

Exceeding the maximum permitted operating cycle can cause the grinder to overheat.

- Do not exceed the maximum operating cycle of three double espressos per minute (5 seconds on/15 seconds off).
- Observe the recommended break when the maximum permitted operating cycle has been reached (see the “Technical data” section).



- The grinder has a release button/thermal overcurrent circuit-breaker **(18)** which breaks the electric circuit of the grinder in the event of electrical overload. In order to start operating the grinder again, switch it off via the power switch and push the release button/thermal overload circuit-breaker **(18)** in. You can then move the on/off switch **(17)** to position I, see the “Troubleshooting” section.
- The grinder also has a motor protector that switches the grinder off if the motor becomes too hot. As soon as the motor has cooled down, the grinder can be used again, see the “Troubleshooting” section.

NOTICE!

Risk of damage!

The user has no control over this circuit-breaker. If the circuit-breaker is triggered multiple times, an authorized service partner must be consulted, as the motor coil could be damaged.

Setting the grind

1. Release the unlocking screw for the grind adjustment **(4)** by turning it anti-clockwise.
2. Set the grind by moving the locking slide **(15)** to the left or right.



- The grind scale **(5)** indicates the grind selected. The finest setting is “0”, the coarsest setting is “10”.
- Only reduce the grind while the grinder is in operation.

3. Lock the grind setting by tightening the unlocking screw on the grind adjustment by turning it clockwise.

Display/navigation symbols

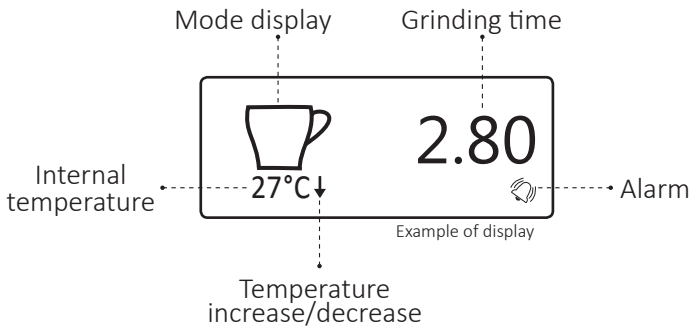

Symbol	Meaning	Symbol	Meaning
←	Navigation to the left	+	Increase input value
→	Navigation to the right	-	Decrease input value
↶	Exit sub-menu	t	Switch to time counter
✓	Open sub-menu / Confirm input	n	Switch to shot counter
X	Reset / Exit menu without saving / Deactivate function		

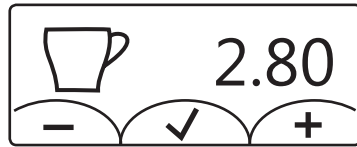

Example of display

- Press the “Single Shot” selection button **(13)** to activate the symbols on the left of the display **(14)**.
- Press the “Double Shot” selection button **(6)** to activate the symbols on the right of the display.
- Press the Start button **(11)** to activate the symbols in the center of the display.



After approx. 1 minute, the grinder switches to standby mode. You can come out of standby mode by pressing any button.

Setting grinding time



- The factory setting for grinding time in Single Shot mode is 2.8 seconds (approx. 10 g).
- The factory setting for grinding time in Double Shot mode is 5.2 seconds (approx. 18 g).

Setting the grinding time for Single Shot mode

1. Press and hold the “Single Shot” selection button **(13)** for two seconds. The current grinding time flashes.
2. Set the grinding time required by pressing the **(13)** or **(6)** selection buttons.
3. Press the Start button **(11)** to save the grinding time setting.



If you do not press any of the buttons for 10 seconds, the display automatically jumps back to the previous mode without saving the setting changes.

Setting the grinding time for Double Shot mode

1. Press and hold the “Double Shot” selection button **(6)** for two seconds.
The set grinding time flashes.
2. Set the grinding time required by pressing the **(13)** or **(6)** selection buttons.
3. Press the Start button **(11)** to save the grinding time setting.



If you do not press any of the buttons for 10 seconds, the display automatically jumps back to the previous mode without saving the setting changes.

Grinding espresso beans

1. Remove the lid from the hopper **(1)**.
2. Fill the hopper with whole roasted espresso beans from the top.
 - The maximum quantity should be about 1 cm below the edge of the hopper.
 - The minimum quantity should not fall below about 2 cm to avoid fluctuations in dosing.
3. Replace the lid on the hopper.
4. Open the hopper slide **(16)** by pushing it backwards.
5. Select the required mode by pressing the **(13)** or **(6)** selection button.
6. Slide the portafilter between the portafilter holder **(7)** and the portafilter fork **(10)**.

Grinding starts automatically.



If you have selected Barista mode, set the grinding time manually. In Single Shot and Double Shot modes, grinding stops automatically as soon as the set grinding time has elapsed.

Interrupting grinding (break function)



You can also switch off the break function, see the section “Setting the break function”.

The break function automatically interrupts grinding if you pull the portafilter out of the portafilter holder **(7)** and continues grinding as soon as you push the portafilter back into the portafilter holder.

1. Pull the portafilter out of the portafilter holder during grinding to interrupt it and stop the grinding time.
The LED and the symbol for the selected setting will flash.
2. Slide the portafilter back between the portafilter holder and the portafilter fork **(10)**.
3. The interrupted grinding process will resume automatically and continue until the grinding time has elapsed.





If you do not wish to continue the grinding process, press one of the two **(13)** or **(6)** selection buttons. The display jumps straight back to the selected mode and the time at which the process was stopped is cleared.

Changing the type of espresso beans

1. Close the hopper slide **(16)** by pushing it forwards.
2. Grind the espresso beans remaining in the grinder until it runs empty.
When there are no more espresso beans in the hopper **(1)**, you can add the new espresso beans. Then proceed as described, starting from step 5.
3. Put the remaining espresso beans into another container.
4. Put the new espresso beans into the hopper.
5. Open the hopper slide by pushing it backwards.
6. Grind 2-3 shots to remove any residue of the old espresso beans and to run in the grinder to avoid fluctuations in dosing.

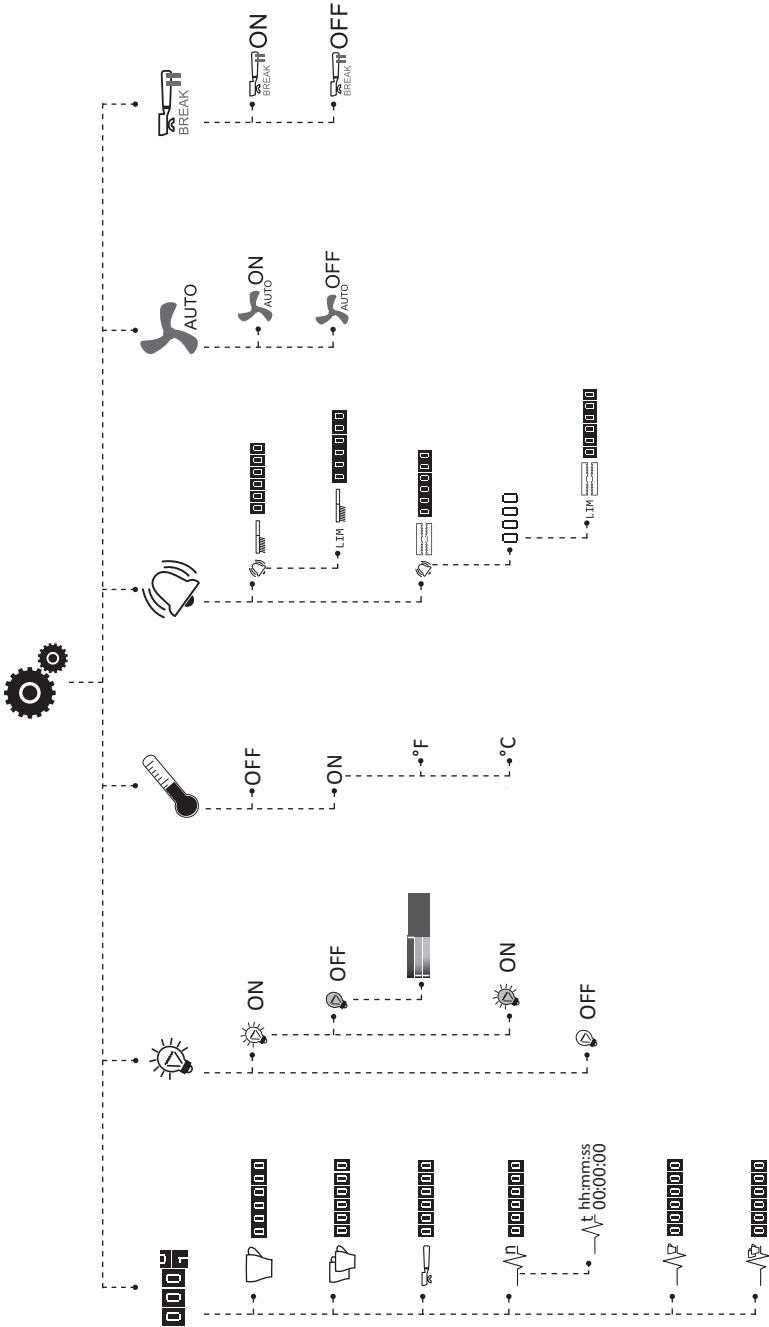
Settings



- Press and hold the **(13)** and **(6)** selection buttons simultaneously for 3 seconds until the  symbol appears on the display. You are now in the main menu and have the option to adjust the counter, light, temperature, alarm, ventilation and break function.
- When you want to leave the main menu, press the **(13)** and **(6)** selection buttons simultaneously again until **EXIT** appears on the display.

Show counter

Single shot counter:

In this sub-menu, the number of single shots ground up to that point is displayed.

- To reset the counter, press and hold the Start button **(11)** until the display has flashed three times and the counter has returned to 0.

Double shot counter:

In this sub-menu, the number of double shots ground up to that point is displayed.

- To reset the counter, press and hold the Start button **(11)** until the display has flashed three times and the counter has returned to 0.

Barista shot counter:

In this sub-menu, the number of Barista shots ground up to that point is displayed.

- To reset the counter, press and hold the Start button **(11)** until the display has flashed three times and the counter has returned to 0.

Total shot counter:

In this sub-menu, the total number of all shots ground up to that point is displayed. Each single shot ground is counted once on the total shot counter, each double shot ground is counted twice. The counter cannot be reset.

 **Operating time counter:**

In this sub-menu, the total operating time for the grinder is displayed. The counter cannot be reset.

 **Total single shot counter:**

In this sub-menu, the number of all single shots ground up to that point is displayed. The counter cannot be reset.

 **Total double shot counter:**

In this sub-menu, the number of all double shots ground up to that point is displayed. The counter cannot be reset.

Setting the light

ON Light ON

In this sub-menu, you can switch the light in the spout **(12)** on. You can select either automatic color change or a constant light color.

OFF Color change OFF

In this sub-menu, you can switch the automatic color change off. If you switch the automatic color change off, you can set the constant light color individually in the next sub-menu.

Setting the light color

In this sub-menu, you can adjust the constant color of the light in the spout individually by pressing the Start button **(11)**.

ON Color change ON

In this sub-menu, you can switch the automatic color change on. The light in the spout changes color automatically in this setting.

OFF Light OFF

In this sub-menu, you can switch the light in the spout off.



Setting the temperature display

OFF Temperature display OFF

In this sub-menu, you can switch off the temperature display for the inside temperature of the grinder.

ON Temperature display ON

In this sub-menu, you can switch on the temperature display for the inside temperature of the grinder.

°F Unit Fahrenheit

In this sub-menu, you can select Fahrenheit as the unit for the temperature display.

°C Unit Celsius

In this sub-menu, you can select Celsius as the unit for the temperature display.



Setting the alarm



Cleaning alarm

In this sub-menu, you can access the remaining number of shots until the next cleaning alarm is triggered.

- To reset the cleaning alarm once cleaning has been completed, exit the menu and press and hold the two **(13)** and **(6)** selection buttons for 10 seconds until RESET appears in the display. The alarm on the display disappears after the reset.



LIM Limit number of shots before cleaning

In this sub-menu, you can set the limit for the number of shots until the cleaning alarm. The default setting is 1,000 shots until the next cleaning.



Grinding disc replacement alarm

In this sub-menu, you can access the remaining number of shots until the grinding disc replacement alarm is triggered.

The default setting is 350,000 shots until the next grinding disc replacement. You cannot set this limit individually.

- When you have reached the grinding disc replacement limit, consult your dealer at the address given in the “Service” section.

Setting the ventilation

ON Ventilation AUTO ON

In this sub-menu, you can switch on automatic operation of the ventilation. The ventilation starts automatically at an internal grinder temperature of 86 °F (30 °C). At 82.4 °F (28 °C), the ventilation switches off again automatically.

OFF Ventilation AUTO OFF

In this sub-menu, you can switch off automatic operation of the ventilation. The ventilation runs continuously, independently of the internal temperature of the grinder.

Setting the break function

OFF BREAK OFF

In this sub-menu, you can switch the break function off. Grinding is not stopped if the portafilter is pulled out of the portafilter fork during grinding.

ON BREAK ON

In this sub-menu, you can switch the break function on. Grinding is stopped automatically if the portafilter is pulled out of the portafilter fork during grinding.

Cleaning

CAUTION!

Risk of injury!

The grinder can fall and cause injury when it is being moved.

- Always place the grinder on a firm surface that will not tilt.
- Ask someone else for assistance if the grinder is too heavy for you.

NOTICE!

Risk of short-circuit!

Water that has penetrated the grinder can cause a short circuit.

- Never immerse the grinder in water or any other liquid.
- Ensure that no water or other liquid can enter the housing in any other way.

NOTICE!

Risk of damage!

Improper handling can cause damage to the grinder.

- Do not use caustic detergents or any sharp or metallic cleaning utensils such as knives, metal scouring pads or similar. These can scratch the surface.
- Do not put the drip tray, hopper or hopper lid in the dishwasher. The parts are not dishwasher-proof and the color may fade.
- Do not lift the grinder by the hopper but by the housing only and always use both hands.

Cleaning the area where the grinder is positioned

1. Switch the grinder off and pull the plug out of the socket.
2. Pick the grinder up by the housing with both hands and place it on a clean surface.
3. Clean the area where the grinder was positioned and the underside of the grinder with a damp cloth and then dry the surfaces off. The surfaces must be dry and free from oil and grease.
4. Put the grinder back in its position on the clean surface.

Cleaning the housing

1. Switch the grinder off and pull the plug out of the socket.
2. Wipe the housing and drip tray **(9)** with a damp cloth as necessary, but at least once a week.
3. Clean the spout **(12)** carefully with the brush **(20)**.

Cleaning the hopper



The hopper must be cleaned of coffee oil residues every day as they can have a negative impact on the taste.

1. Close the hopper slide **(16)** by pushing it forwards.
2. Put the espresso beans into another container.
3. Clean the hopper inside and out with a damp cloth and then dry it.
4. Put the espresso beans back into the hopper and open the hopper slide by pushing it backwards.

Cleaning the burr



- The manufacturer recommends using GRINDZ™ grinder cleaner. You can find further information about GRINDZ™ at www.dittingswiss.ch.
- The burr should be cleaned every 2-5 days.

1. Close the hopper slide **(16)** by pushing it forwards and grind the espresso beans remaining in the grinder until it runs empty.
2. When there are no more espresso beans in the hopper **(1)**, you can add the grinder cleaner. Follow the manufacturer's specifications for the quantity of grinder cleaner to use. Then proceed as described, starting from step 4.
3. Put the remaining espresso beans into another container.
4. Set the grind to "10" (see the section "Setting the grind").
5. Put the grinder cleaner into the hopper. Follow the manufacturer's specifications for the quantity of grinder cleaner to use.
6. Place a bowl under the spout **(12)** to catch the grinder cleaner.
7. Select Barista mode (see the section "Putting the grinder into operation and selecting the mode").
8. Press the Start button **(11)** until the grinder cleaner is completely ground.
9. Wipe out the hopper with a dry, lint-free cloth.
10. Put the espresso beans back into the hopper.
11. Open the hopper slide by pushing it backwards.
12. To remove the remaining cleaning particles, grind about the same quantity of espresso beans as the quantity of grinder cleaner used. During the grinding process, set the grind as required.
13. Dispose of the ground grinder cleaner and the ground espresso beans in the commercial/household waste.
14. Reset the cleaning alarm, see the section "Setting the alarm".

Troubleshooting

Fault	Cause	Remedy
<p>The grinder makes a buzzing noise but does not grind.</p>	<ul style="list-style-type: none"> • The spout is blocked. 	<p>→ Set the grind to “10” and start the grinding process. The grinder clears itself. Then put the grind setting back to the grind you require while the grinder is running.</p>
	<ul style="list-style-type: none"> • The adjustable spout has been pushed too far back and is blocking the flow of coffee. 	<p>→ Pull the spout forward until it stops. Set the grind to “10” and start the grinding process. The grinder clears itself. Then put the grind setting back to the grind you require while the grinder is running.</p>
	<ul style="list-style-type: none"> • Ground coffee has become blocked in the grinder because the portafilter has been overfilled. 	<p>→ With the grinder switched off, clean the spout from the outside with the brush. Set the grind to “10” and start the grinding process. The grinder clears itself. Then put the grind setting back to the grind you require while the grinder is running.</p>

Fault	Cause	Remedy
	<ul style="list-style-type: none"> • The grind is too fine. • A foreign object is in the burr. 	<ul style="list-style-type: none"> → Set the grind to “10” and start the grinding process. The grinder clears itself. Then put the grind setting back to the grind you require while the grinder is running. If the problem is not resolved, consult your dealer at the address given in the “Service” section. → Clean the burr as described in the “Cleaning” section and remove the foreign object as you do so. If the foreign object cannot be removed in this way, consult your dealer at the address given in the “Service” section.
<p>The grinder does not grind, the display is illuminated, the grinding mode has been preselected.</p>	<ul style="list-style-type: none"> • The grinding time is set to 0. • The maximum permitted operating cycle has been exceeded. 	<ul style="list-style-type: none"> → Reset the grinding time. → If necessary, switch the ventilation to AUTO and wait until the ventilation switches off automatically at 82 °F (28 °C).
<p>The grinder does not start up, the display is not illuminated.</p>	<ul style="list-style-type: none"> • The power plug is not plugged into the socket. 	<ul style="list-style-type: none"> → Insert the plug into a correctly installed socket.

Fault	Cause	Remedy
	<ul style="list-style-type: none"> <li data-bbox="347 172 604 276">• The overcurrent circuit-breaker has been tripped. <li data-bbox="347 512 604 576">• The electric fuse has been tripped. 	<p data-bbox="616 172 1008 416">→ Check if the release button on the circuit-breaker has popped out. If necessary, push it in again. If the button continues to pop out, consult your dealer at the address given in the “Service” section.</p> <p data-bbox="616 512 1008 823">→ Check the electric fuse. Reset or replace it. Check whether other electric consumers are connected to this fuse and, if necessary, unplug them. If the fuse is tripped repeatedly, consult your dealer at the address given in the “Service” section.</p>
<p data-bbox="117 845 324 949">The grinder’s dosing accuracy is decreasing.</p>	<ul style="list-style-type: none"> <li data-bbox="347 845 604 1021">• The spout is blocked. Too much ground coffee has become blocked inside the grinder. <li data-bbox="347 1228 604 1332">• The built-in grinder spout is damaged. 	<p data-bbox="616 845 1008 1165">→ With the grinder switched off, clean the spout from the outside with the brush. Set the grind to “10” and start the grinding process. The grinder clears itself. Then put the grind setting back to the grind you require while the grinder is running.</p> <p data-bbox="616 1228 1008 1332">→ Consult your dealer at the address given in the “Service” section.</p>

Fault	Cause	Remedy
	<ul style="list-style-type: none"> <li data-bbox="330 175 532 239">• The flapper is defective. 	<ul style="list-style-type: none"> <li data-bbox="610 175 991 271">→ Consult your dealer at the address given in the “Service” section.
<p data-bbox="106 375 308 470">The grinder does not grind sufficiently finely.</p>	<ul style="list-style-type: none"> <li data-bbox="330 375 588 502">• The grinding discs have moved out of place and require adjustment. 	<ul style="list-style-type: none"> <li data-bbox="610 375 991 470">→ Consult your dealer at the address given in the “Service” section.
<p data-bbox="106 574 308 742">The grinder does not dose the coffee into the center of the portafilter.</p>	<ul style="list-style-type: none"> <li data-bbox="330 574 554 670">• The spout is not set correctly for the portafilter. 	<ul style="list-style-type: none"> <li data-bbox="610 574 991 742">→ Push the spout into the correct position so that the dispensing cone is in the center of the portafilter when grinding is complete.
<p data-bbox="106 901 240 997">The display is showing “Service”.</p>	<ul style="list-style-type: none"> <li data-bbox="330 901 576 1029">• The display is not receiving all of the information required. 	<ul style="list-style-type: none"> <li data-bbox="610 901 991 997">→ Consult your dealer at the address given in the “Service” section.

Technical data

Model:	PEAK
Voltage / frequency:	100–120 V / 50 Hz 100–120 V / 60 Hz 200–240 V / 50 Hz 200–240 V / 60 Hz
Protection type:	IPX1
Protection class:	I ⊕
Fuse:	16 A-slow
Idling speed:	
50 Hz:	900 rpm
60 Hz:	1100 rpm
Noise emission level:	
Idling:	55 dB
Grinding:	75 dB
Grinding capacity:	2.0–3.5 g/s*
Max. permitted operating cycle:	4 double espressos/min. (5 seconds on/15 seconds off)
Recommended break:	15 s
Max. grinding time:	20 min.
Max. daily output:	66.1 lbs (30 kg)
Dimensions (W × H × D)	9.5 × 21.7 × 12.6" 240 × 550 × 320 mm
Weight (net):	30.9 lbs (14 kg)
Max. hopper capacity:	3.3 lbs (1.5 kg)

*Depending on the espresso beans and the grind selected.

Disposal

Disposing of the packaging

- Sort the packaging before disposing of it. Put the paper and cardboard in the paper recycling, put the film in the bin for reusable materials.

Disposing of the grinder

- Should the cooler no longer be capable of being used at some point in time, dispose of it in accordance with the regulations in force in your city or state.
- Please ensure your recycling information applies to the local regulations and EPA recommendations (www.epa.gov).

Service

Consult your dealer if you require service. Our directory of dealers with all of their contact details is available for you to download at www.dittingswiss.ch.

The version of the grinder is shown when it is switched on. Give this to your dealer if you require service.

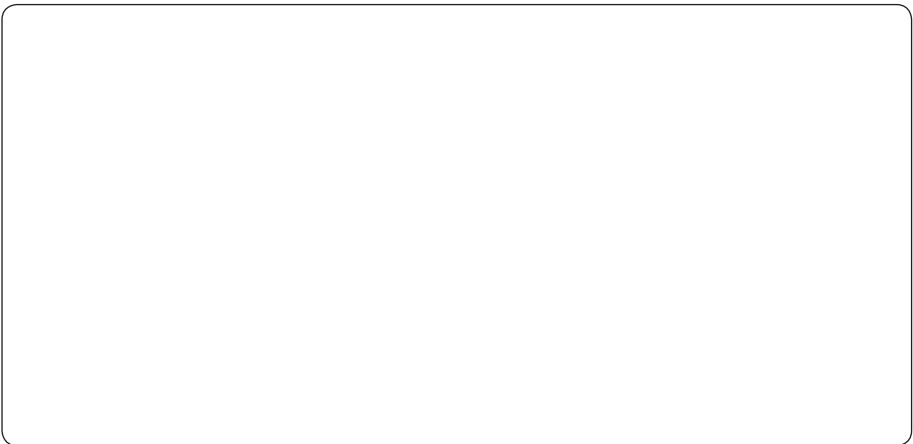

Dealer's stamp

CE Declaration of Conformity

EC DECLARATION OF CONFORMITY



The manufacturer:

HEMRO AG
Länggenstrasse 34, 8184 Bachenbülach, Switzerland
Tel.: +41 44 864 18 00
Fax: +41 44 864 18 01

Hereby declares that the below mentioned product:

Product: Device for food processing
Machine model: Coffee grinder
Type of machine: PEAK

Following directives, regulations and standards have been applied:

2006/42/EG	The provisions of the Machinery Directive
2014/35/EU	The Low Voltage Directive
2014/30/EU	The EU Electromagnetic Compatibility Directive (EMC)
2011/65/EU	The RoHS Directive on the restriction of use of certain hazardous substances in electrical and electronic equipment
(EG) No.1907/2006	The EU chemicals regulation (REACH – Regulation)
2012/19/EU	WEEE Regulation - Waste of Electrical and Electronic Equipment
EN 60335-1:12+A11:14	Safety of electrical appliances for household, general requirements
EN 60335-2-64:00+A1:02	Safety of electrical appliances for household, particular requirements for commercial use
EN 62233:08	Measurement methods for electromagnetic fields
EN 55014-1:12	Electromagnetic compatibility, Emission (EMC)
EN 55014-2:16	Electromagnetic compatibility, Immunity (EMC)
EN 61000-3-2:15	Electromagnetic compatibility, Emission (EMC)
EN 61000-3-3:14	Electromagnetic compatibility, Emission (EMC)

Supplements in Europe:

Regulation 1935/2004	Requirements for materials and the objects with food comes into contact
Regulation 2011/10/EU	Requirements on plastic materials and articles intended to come into contact with food
Regulation 2023/2066	Rugulation on good manufacturing practice for materials and articles intended to come into contact with food

Documentation agent:	Metin Makinaci
Address of the proxy documentation:	See the address of the manufacturer
Done in Hamburg on:	04/11/2017
Function of subscriber:	General Manager
Name of signatory:	Philipp Baumberger

Signature

COMPANY OF THE
HEMRO
Global Coffee Grinding Solutions

MAHLKÖNIG GmbH & Co. KG
Amtsgericht Hamburg HR A 5 074; Persönlich haftende Gesellschafterin:
Beteiligungsgesellschaft MAHLKÖNIG mbH, Eingetragten Amtsgericht Hamburg HR B 45 324,
Geschäftsführer: Philipp Baumberger, Jochen Christoph
Ust. Id. Nr.: DE 118 37 22 85

Complaint report

REKLAMATIONSBERICHT / CLAIM REPORT REPARATURAUFTRAG / SERVICE ORDER



Händler Dealer			
Kunde Customer			
Straße Street	Maschinentyp Machine type		
PLZ Zip code	Serien Nr. Serial no.		
Stadt City	Betriebsstunden Operating hours		
Land Country			
E-Mail Email	Warenerhalt Datum Date of receipt of goods		
Telefon Phone	Fax		

Mängel sind sofort zu melden Claims have to be reported immediately.

Äußere Mängel an der Verpackung Defects of packaging from the outside

Ja (bitte Foto beifügen) (please enclose a photo) Nein

Wenn „Ja“ Beschreibung If „yes“ describe

Schadensmitteilungen an Transporteur Information to transport company

Ja Nein

Äußere Mängel an der Mühle Defects of the grinder from the outside

Gehäuse Housing Oberteil Upper part Unterteil Lower part Deckel Lid Grundplatte Ground plate Rüttelblech Vibrating sheet

Sonstiges Others

Funktionsprüfung Operational Test

Mühle läuft nicht an Grinder does not start	<input type="checkbox"/>	Mühle läuft unter Last nicht an Grinder does not start under load	<input type="checkbox"/>	Sicherung Mühle geprüft Fuse inspected	<input type="checkbox"/>
Steckdosensanschluss geprüft Plug connection inspected	<input type="checkbox"/>	Trichter ist nicht verstopft Hopper is not blocked	<input type="checkbox"/>	Sicherung Gebäude geprüft Building fuse inspected	<input type="checkbox"/>
Motor funktioniert, mahlt aber nicht Motor is running, but does not grind	<input type="checkbox"/>	Bei 3 Phasen Mühlen Drehrichtung kontrolliert Direction of rotation inspected (only for 3 phase grinders) under load	<input type="checkbox"/>	Mühle mahlt zu grob Grinder grinds too coarse	<input type="checkbox"/>
Schalter bis zur Einrastung betätigt Switch locked	<input type="checkbox"/>	Mühle ist zu laut Grinder is too noisy	<input type="checkbox"/>		

Display Display

Fehlermeldung im Display Alarm message in the display

Display ohne Anzeige Display without indication

Bemerkungen Notes





COMPANY OF THE HEMRO GROUP

 Ditting Maschinen AG
Längenstrasse 34
CH-8184 Bachenbülach
Switzerland

 +41 44 864 18 00

 www.dittingswiss.ch