

Operations Manual

Vantage Light - Single Lid Clamshell Grill
Model #: CS157TBA



PROLUXE
WWW.PROLUXE.COM

Version: 51719

Congratulations on your selection of the Vantage Light Clamshell Grill. Proluxe is a leading manufacturer of food preparation and cooking equipment designed for the most demanding commercial kitchens. Proluxe equipment is a result of the highest quality engineering and time-tested design.

This manual includes installation, operation, and maintenance procedures for your new clamshell grill. Please read this manual carefully and keep it with your machine for proper operation and lasting service.

Electrical:
120V/50-60Hz/1150W/9.6 Amps
1 phase

Also available; specify when ordering:

- Voltage: 120/220
- Amps: 9.6/5.2
- Watts: 1150/1150

Includes: 72" cord and 6-30P NEMA approved plug.

Controlled heating zones: 2

Shipping Weight:
68lbs. (30kg)

GETTING STARTED

Please read carefully before attempting to use this appliance.

1. Place in a location where it will be used allowing for clearances per the dimensions indicated. Allow 2" minimum clearance between adjacent equipment and/or wall areas.
2. Plug into proper 3 prong wall outlet. If other appliances are connected to the same circuit make sure the total load does not exceed a maximum ampacity of the circuit. Electrical information is as follows:
3. Press the power button, the green light above will illuminate when powered on. The display flashes and shows left preset timer during warm-up. Preheat time will be approximately 40-50 minutes. When the set point is reached, the display stops flashing and beeps 3 times.
4. Simply place the product in the center the grill, close lid and press the desired preset time cycle 10 or 20 seconds. After the time cycle is finished press it again to reset the time cycle.

TEMPERATURE/TIMER SETTINGS

How to Find Set Temperature

To find the temperature of upper platens: Press and hold the TEMP button and the arrow up (↑) button at the same time.

To find the temperature of bottom platens:
Press and hold the TEMP button and the arrow down (↓) button at the same time.

Adjusting the Set Temperature

1. Press and hold the TEMP button and the arrow up (↑) button at the same time for 15 seconds.
2. The current temperature with display on the right digital display screen only.
3. Using the up (↑) and down (↓) adjust the temperature to your desired setting.
4. Once your desired temperature is set, push the TEMP button to return.

Adjusting the Set Time

1. Press the TEMP button first and then select the desired timer button and hold for 5 seconds.
2. The current temperature with display on the right digital display screen only.
3. Using the up (↑) and down (↓) adjust the timer to your desired setting.
4. Once your desired temperature is set, push the TEMP button to return.

Note: When adjusting the timer settings, the right set of buttons control the left side. Your left side timer will automatically set to your right control settings. If you desire a separate left timer you can manually adjust

the left side timer without affecting the right timer.

CLEAN CYCLE

Start Cycle

To start a clean cycle, push CLEAN button once so the CLEAN LED light is turned on. All preset LED's are turned off, and the temperature set point is changed to the clean set point of 275°F. This also initiates the cool down to clean set point condition as well the display starts flashing until the clean set point is reached.

Stop Cycle

To stop the clean cycle, simply press the CLEAN button once to deactivate the clean cycle. The CLEAN LED is turned off, the preset LED's are restored, the temperature set point is changed to the main set point. Again, the warm-up condition is initiated and the display flashes until the cook set point is reached.

Change Clean Temp

275°F is the factory default temp for the CLEAN cycle. To change the CLEAN cycle temp, simultaneously hold down the TEMP and CLEAN buttons for 15 seconds. The current temp setting will display on the right digital display only. Using the up or down arrows to adjust to the desired temp.

PREVENTATIVE MAINTENANCE

Proluxe machines are relatively maintenance-free. For a long lifespan, the

following preventative maintenance should be followed:

Daily Care:

1. Platens: Turn your machine off and allow to cool down before attempting to clean. These platens should only be cleaned with mild soap and warm water then wiped off with a clean, soft cloth or soft sponge.

2. Exterior surfaces: Wipe daily with mild soap and warm water.

DO NOT use ice or cold water to cool the unit down. This can cause platens to warp.

Service Problems:

Contact our factory at (800) 624-6717 (U.S. only) or approved service agency. When contacting the factory for information, parts or service instructions, please provide the serial number of the machine be provided. This number can be found on the serial plate located on the rear of the machine.

Vantage Light Troubleshoot Guide - Model #: CS157

Problem	Cause	Action	Ref #
Power button on digital controller face is depressed but doesn't turn on.	1. Power cord is not plugged in.	1. Plug the power cord into wall receptacle and power button.	----
	2. Circuit breaker is tripped off in the site's breaker box.	2. Reset circuit breaker that the grill is plugged into. Depress Power Button to turn on.	----
	3. Transformer has taken an electrical surge and is damaged.	3. Replace Transformer after you check the secondary side of the transformer. If working properly, you should receive 12vdc.	18
	4. Check the voltage on the secondary side of the transformer. If you read 12VDC then you are receiving voltage to the controller.	4. Replace controller. Controller should be on once the power button is depressed.	A8
	5. Possible blown fuse.	5. Replace fuse.	98
Digital controller's LED's are scrambled or randomly erratic. If when turning on, the display will first go to segment check	1. Possibly a component on the Digital controller is damaged.	1. Replace digital controller.	A8
	2. Control needs to reset.	2. While the unit is on unplug unit, wait for 1 min. Then plug machine on again and depress the power button.	----
Digital controller is constantly beeping. No heat on either on left, right, upper, or lower platen.	Sensor in one of two zones lost its continuity. Depress TEMP. While depressing TEMP depress either up or down arrow to locate error message PROB (zone 1, lower platen, zone 2 left upper platen, zone 3, right upper platen.) If occurred when depressing the up arrow indicates either the left or right platen has the open sensor or Probe.	Disconnect probe and check for continuity (by using Ohm Meter) and replace. Do not cut and splice new sensor. Install new 2000 ohm RTD sensor to underside of the platen and reconnect to controller. Upper left and right sensor for replacement on upper platens, lower platen sensor for replacement for lower platen.	22 46
Digital display shows PROB. No heat on any platen.	Sensor lost it's continuity as shown on a multi-meter.	Disconnect prob that is open (no continuity as shown on a multi-meter. Must replace sensor (RTD). Do not cut and splice new sensor. Install a new 2000 ohm RTD sensor to under side of heat	41

		platen and reconnect to the controller.	
Digital controller beeping and is overheating.	The mechanical relay on the switched side is not opening to regulate temperature. Hold TEMP button then depress either the down or up arrow (zone 1, lower platen, zone 2, left upper platen and zone 3, right upper platen.) RLY will display on problem zone indicating the damage.	Replace the mechanical relay.	15
Either platen is not heating but the digital controller is on and appears to be functioning.	If the mechanical relay(s) on the coil side are receiving 12vdc indicates the controller is functioning properly. If there is no voltage on the switching side of the relay to the heaters, the relay is not working properly.	Replace the mechanical relay.	15
Beeper is not functioning.	Beeper has failed.	Replace control board.	A8
One of the three heater platens not close to set point.	The offset function in the controller's setting needs to be adjusted to achieve proper shade of toast.	Call (800) 624-6717 for instructions.	----
One heating zone is not reaching setpoint and another heater is overheating.	Sensors maybe crossed.	Make sure each sensor is connected to its prospective position on the terminal block and back to the controller.	----
Setpoint is reached but slightly off in temperature.	Offset may need to be calibrated and adjusted.	Call (800) 624-6717 for instructions.	----
Heater platen is overheating.	<ol style="list-style-type: none"> 1. The mechanical Relay may be stuck in the closed position (zone 1, lower platen #1 labeled on this relay, zone 2, left upper and zone 3, right upper). 2. If you are receiving 12vdc on the coil of the relay, the controller is properly functioning. 	Use an Ohm meter for a continuity check must check at the cold pins of the heater (where the heater wire is brazed at the cold pin. This will eliminate any other failure before the heater element validating the loss off continuity at the source the heater element.	15
Upper heater not coming down parallel to the lower platen.	Parallel lever not attached either in the rear out on the upper heater platen. Check to see if parallel lever	Reconnect the pin and the retaining E-Clip.	25

	is connected on both sides. The retaining clip attached to pin may have come off.		
Upper platen falling down or lost tension.	The springs have lost some tension.	Remove rear panel and adjust the retaining collars on shaft by winding the spring tighter. There are multiple set screws that need to be loosened in order to wind the spring tighter. Once proper tension is achieved, tighten all set screws to prevent tension loss.	----

MODEL CS157

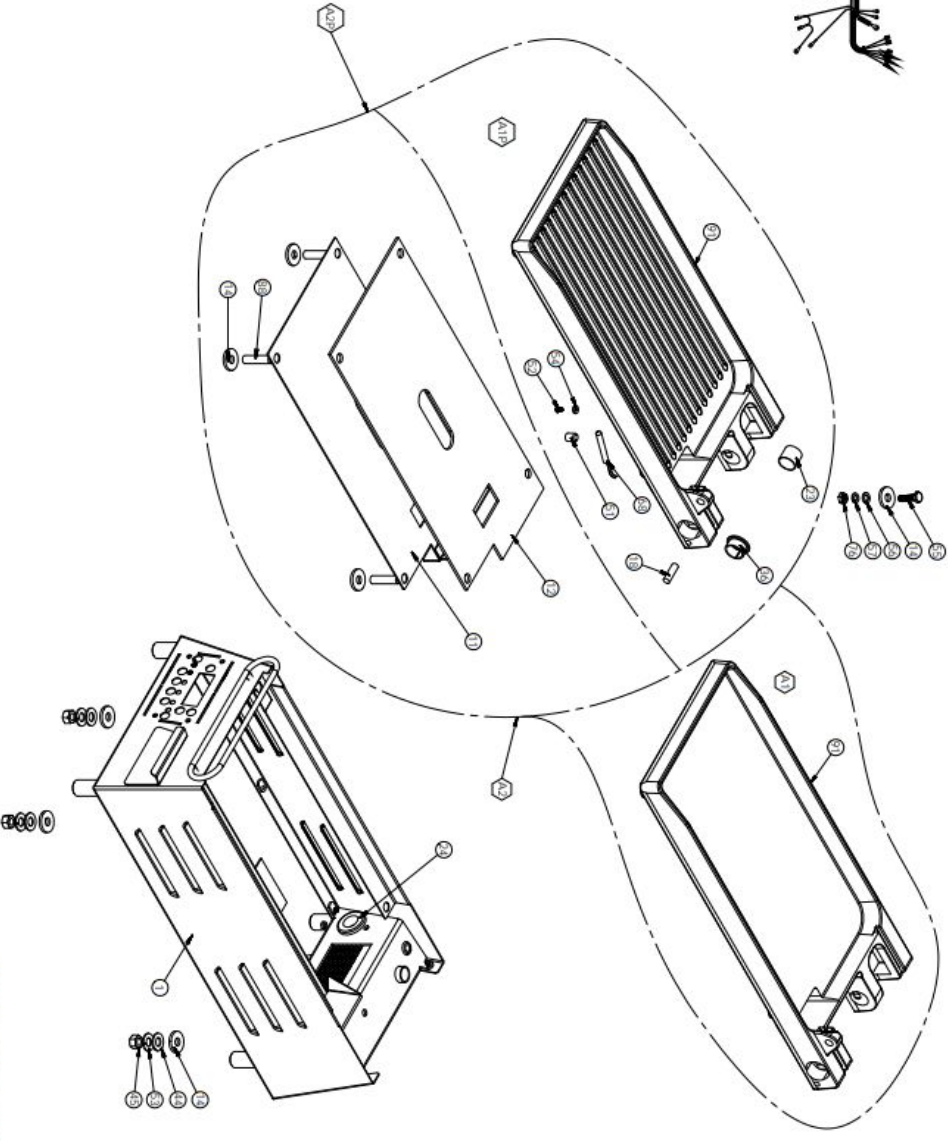

EXP CS157 RA 1012 060414
SHEET 1 OF 3

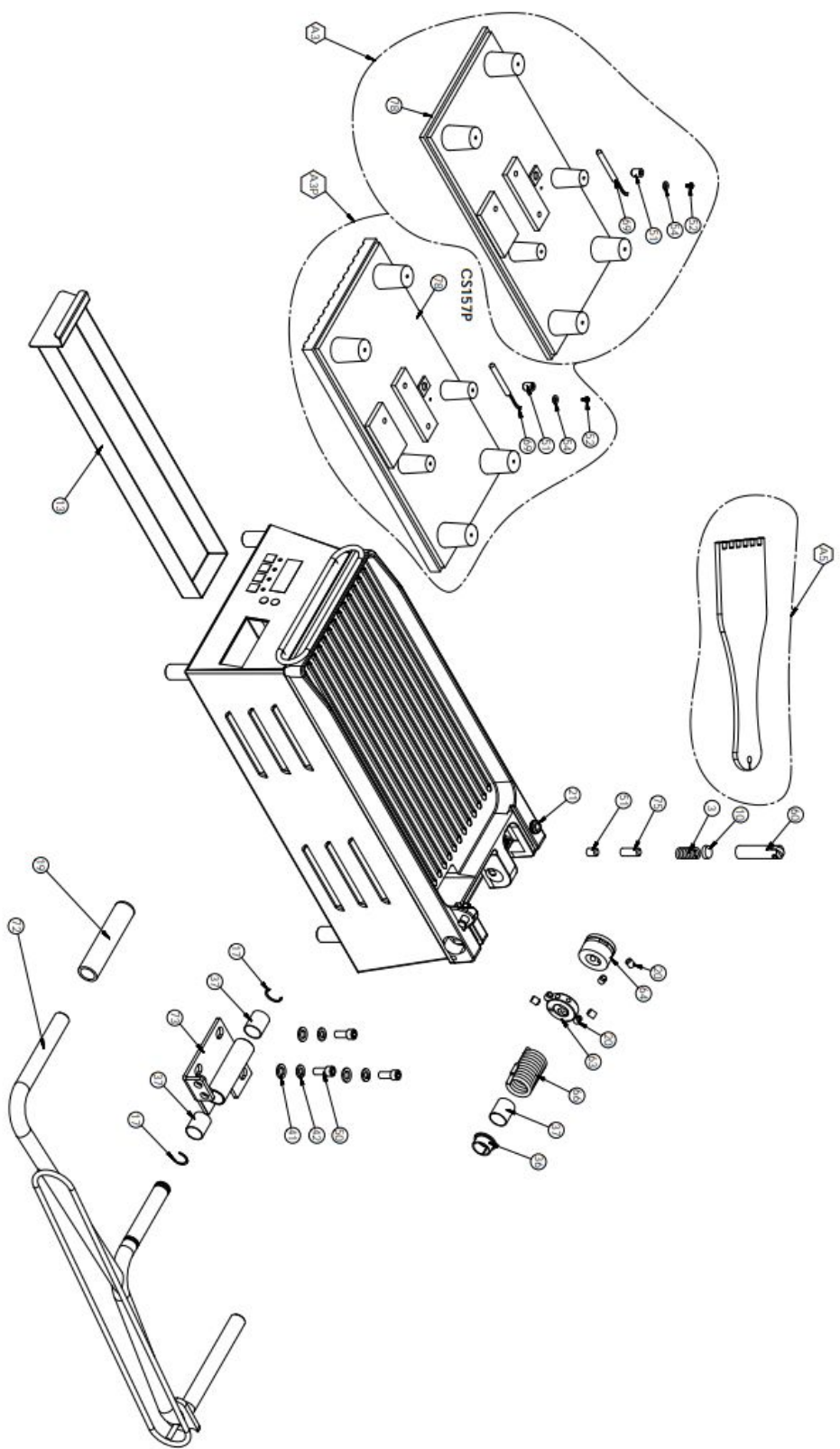

EXPC157 RA 1012 060414
 SHEET 2 OF 3

MODEL CS157

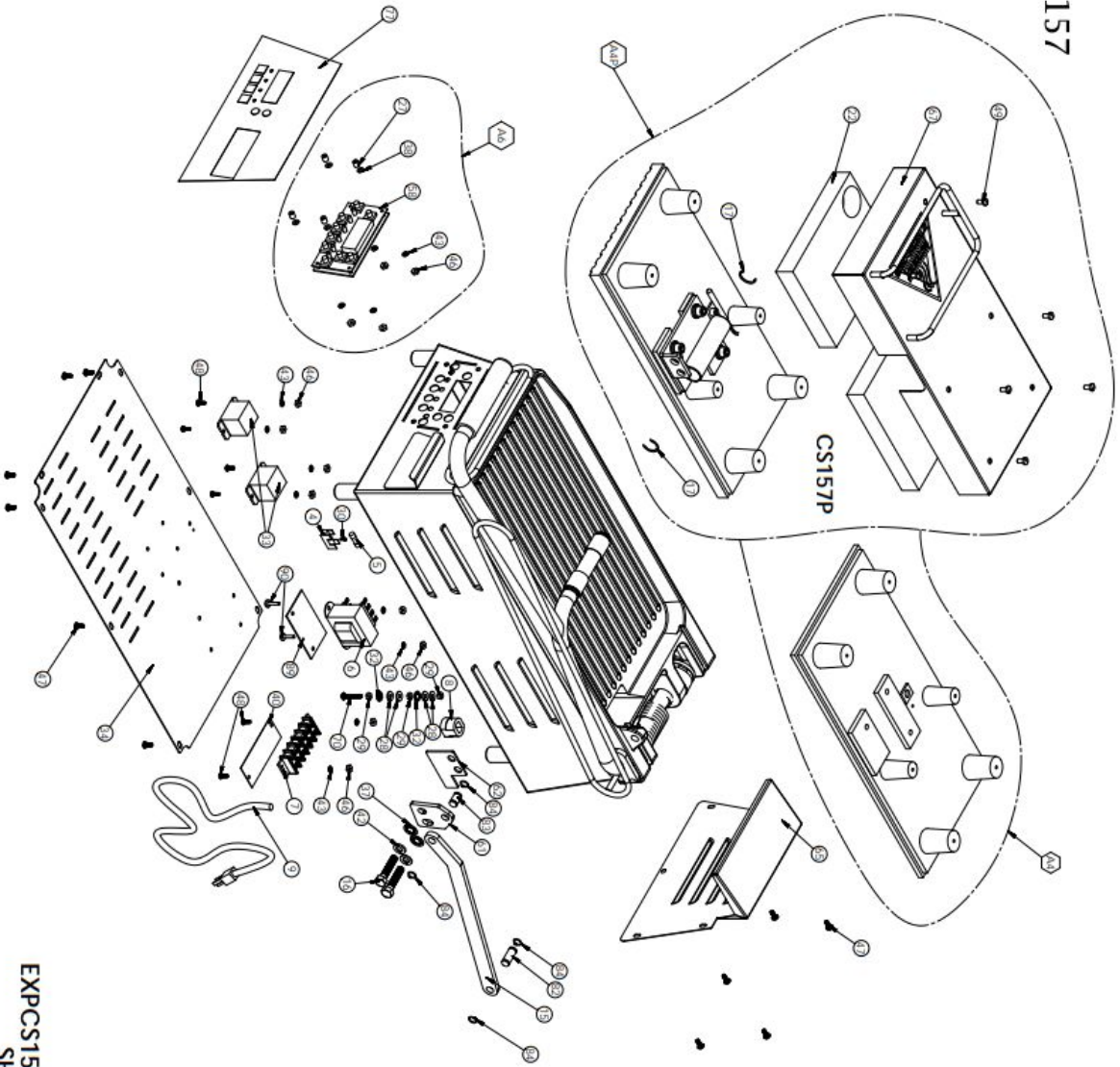

EXPC157 RA 1012 060414
SHEET 3 OF 3

Vantage Light Part List - Model #: CS157

ITEM #	DESCRIPTION	MODEL CS157A 120V	MODEL CS157PA 120V	MODEL CS157CEC 220V	QTY.
1	LOWER WRAP AROUND SHROUD ASSEMBLY	110103901	110103901	110103901	1
3	SPRING, DETENT 1/2 LONG	110115555	110115555	110115555	1
4	FUSE HOLDER	MPPF708	MPPF708	MPPF708	1
5	FUSE BUSS 1 AMP	MPPF701R	MPPF701R	MPPF701R	1
6	TRANSFORMER	11096975	11096975	11096975	1
7	TERMINAL BLOCK #6	6016	6016	6016	1
8	STRAIN RELIEF	11016546468	11016546468	11016546468	1
9	CORD, POWER	110969174	110969174	MPPW202	1
10	TUBBING-PAD	110115531	110115531	110115531	1
11	COVER, LOWER PLATTEN ASSEMBLY	110103909	110103909	110103909	1
12	LOWER PLATEN INSULATION	110103910	110103910	110103910	1
13	GREASE TRAY	110103903	110103903	110103903	1
14	GREEN INSULATION WASHER	C4401	C4401	C4401	9
15	TOP LINK	110115508	110115508	110115508	1
16	BOLT, HEX 5/16-18 X1 STAINLESS STEEL	BH516181S	BH516181S	BH516181S	2
17	E-CLIP, RETAINING RING	LCC3478	LCC3478	LCC3478	2
18	PIN, BACK STOP	110115543	110115543	110115543	1
19	HANDLE GRIP	110901168	110901168	110901168	1
20	SCREW SET KNURLED CUP POINT 5/16-18 x 3/8	SST5161838KN	SST5161838KN	SST5161838KN	6
21	RUBBER GROMET, 5/16 X 1/2	110115554	110115554	110115554	1
22	INSULATION, UPPER PLATEN RIGHT HAND	110888251R	110888251R	110888251R	1
23	BUSHING, TEFLON , 3/4	110113441	110113441	110113441	1
24	GROMET, RUBBER 3/4 X 1 3/8	110103919	110103919	110103919	1
27	SPACER, NYLON 1/4X.141 X 9/32	11090109	11090109	11090109	4
28	WASHER, SAE #8	WSAE8	WSAE8	WSAE8	4
29	NUT, HEX 8-32	NH832	NH832	NH832	3
30	SCREW, PAN HEAD PHILLIPS 2-56 X 1/4	SP25614	SP25614	SP25614	1
31	WASHER INTERNAL TOOTH LOCK 5/16	WLIT516	WLIT516	WLIT516	2

32	WASHER INTERNAL TOOTH LOCK #8	WLIT8	WLIT8	WLIT8	2
33	RELAY	110942520	110942520	110942520	2
34	BOTTOM COVER	110103917	110103917	110103917	1
36	FLANGE TEFLON BUSHING 1/2	110115563	110115563	110115563	1
37	BUSHING TEFLON 1 LONG	110115541	110115541	110115541	3
38	WASHER, STEEL	311150019	311150019	311150019	4
40	MARKER STRIP #6 DOUBLE	MS6016	MS6016	MS6016	1
41	WASHER, CUT 5/16	WC516	WC516	WC516	3
42	WASHER, SPLIT LOCK 5/16	WL516	WL516	WL516	5
43	WASHER, INTERNAL TOOTH LOCK #6	WLIT6	WLIT6	WLIT6	12
44	WASHER, SAE 3/8	WSAE38	WSAE38	WSAE38	4
45	NUT, HEX 3/8-16	NH3816	NH3816	NH3816	4
46	NUT, HEX 6-32	NH632	NH632	NH632	12
47	SCREW, PHILLIPS 8-32X3/8 STAINLESS STEEL	SP83238S	SP83238S	SP83238S	13
48	SCREW, PHILLIPS 6-32X3/8	SP63238	SP63238	SP63238	6
49	SCREW, PAN HEAD SLOTTED 10-32 X 3/8 STAINLESS STEEL	SPS103238S	SPS103238S	SPS103238S	6
50	SCREW, SOCKED HEAD 5/16-18 X 3/4	SSH5161834	SSH5161834	SSH5161834	3
51	SCREW, SET 3/8-16 X 1/2	SST381612	SST381612	SST381612	3
52	SCREW, PAN HEAD PHILLIPS 6-32 X 1/4	SP63214	SP63214	SP63214	2
53	WASHER, SPLIT LOCK 3/8	WL38	WL38	WL38	4
54	WASHER, SAE #6	WSAE6	WSAE6	WSAE6	2
55	BOLT, HEX 1/4-20 x 1 STAINLESS STEEL	BH14201S	BH14201S	BH14201S	1
56	WASHER, SAE 1/4	WSAE14	WSAE14	WSAE14	1
57	WASHER, SPLIT LOCK 1/4	WL14	WL14	WL14	1
58	DIGITAL CONTROL	110171433052	110171433052	110171433052	1
60	PLUNGER ASSEMBLY	110115544	110115544	110115544	1
61	UPPER LEVELING BRACKET	110115510	110115510	110115510	1
62	UPPER LEVELING SHIM	110115557	110115557	110115557	1
63	HANDLE, SPRING ADJUSTING COLLAR	110115528	110115528	110115528	1
64	COLLAR, HOLDER	110115530	110115530	110115530	1
65	BACK COVER	110103907	110103907	110103907	1
66	COUNTER BALANCE SPRING	1101039154	1101039154	1101039154	1
67	RIGHT SHROUD ASSY	11016546455	11016546455	11016546455	1
68	RTD SENSOR	1108881102	1108881102	1108881102	1

69	RTD SENSOR	1108881101	1108881101	1108881101	1
70	SCREW, PAN HEAD PHILLIPS 8-32 X 1	SP8321	SP8321	SP8321	1
72	HANDLE RIGHT ASSEMBLY	110103916	110103916	110103916	1
73	CLEVIS ASSY, RIGHT HAND	110115504	110115504	110115504	1
75	SCREW, SET 3/8-16 X 1	SST38161	SST38161	SST38161	1
76	NUT, SERRATED FLANGED HEX 1/4-20	NHSF1420	NHSF1420	NHSF1420	1
77	OVERLAY	OCS157TBB	OCS157TBB	OCS157TBB	1
78	UPPER PLATEN, RIGHT	110115540R120	110115575R120	110115540R220	1
79	WIRE HARNESS	110103950	110103950	110103950	1
82	PIN, PIVOT BACK	110115566	110115566	110115566	1
83	PIN, PIVOT FRONT	110115565	110115565	110115565	1
84	RETAINING RING	110115567	110115567	110115567	4
87	MANUAL CS157	MSCS157	MSCS157	MSCS157	1
88	SCREW, SET 3/8-16 X 1 1/2	SST3816112	SST3816112	SST3816112	4
89	TRANSFORMER INSULATION	1101159180	1101159180	1101159180	1
90	SCREW, PHILLIPS 6-32X5/8	SP63258	SP63258	SP63258	2
91	LOWER PLATEN	110103932	110103932P	11010393220	1
A1	LOWER PLATEN WITH WIRING	110103932207	N/A	110103932102K	1
A1P	LOWER PLATEN PANINI WITH WIRING	N/A	110103932307	N/A	1
A2	LOWER PLATEN ASSEMBLY	110109332K	N/A	110103932203K	1
A2P	LOWER PLATEN PANINI ASSEMBLY	N/A	110103932PK	N/A	1
A3	UPPER PLATEN RIGHT HAND WITH WIRING	1101155204	N/A	1101155204	1
A3P	UPPER PLATEN PANINI RIGHT HAND WITH WIRING	N/A	1101155304	N/A	1
A4	UPPER PLATEN RIGHT HAND ASSEMBLY	1101155113	N/A	1101155114	1
A4P	UPPER PLATEN PANINI RIGHT HAND ASSEMBLY	N/A	1101155313	N/A	1
A5	SCRAPER, PANINI	N/A	110115580	N/A	1
A6	KITTED, PROGRAMMED CONTROLLER TEMPERATURE ASSEMBLY	110171433052K	110171433052K	110171433052K	1

VAC: 120,(220)
 WATT: 1150W, (1150W)
 AMPS: 9.6,(5.2)

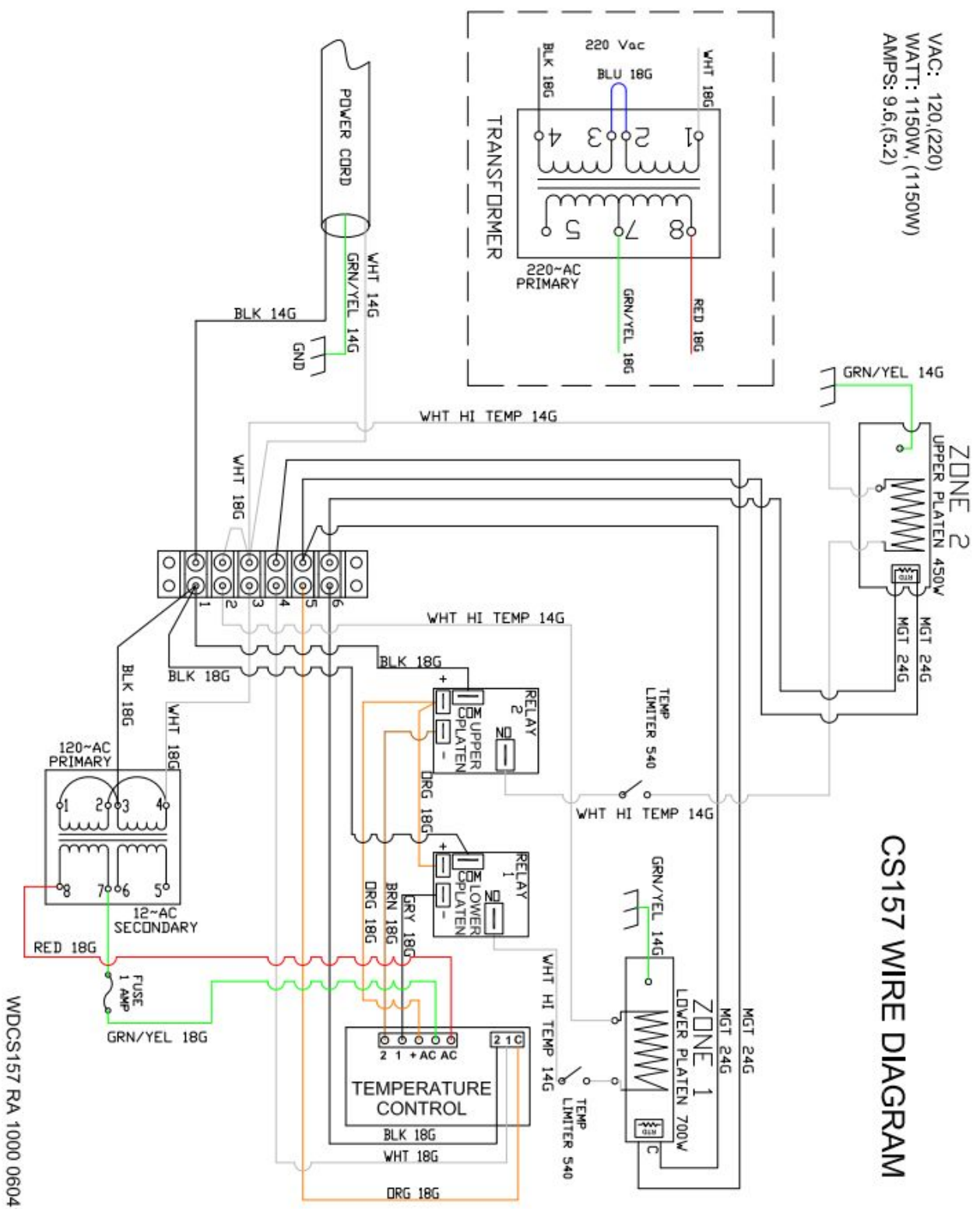

CS157 WIRE DIAGRAM

WDCS157 RA 1000 060414

Warranty & Return Policy

Proluxe warrants all products manufactured by it against defects in workmanship or materials from the date of purchase for a period of 1 year on parts and labor. This warranty applies to only equipment purchased and used in the United States.

Warranty period shall begin when equipment ships. Warranty travel will only be covered for 60 miles.

ALL WARRANTY SERVICE CALLS MUST BE APPROVED BY PROLUXE. IF THIS PROCEDURE IS NOT FOLLOWED, WARRANTY SERVICE WILL NOT BE COVERED. WARRANTY SERVICE WILL BE PAID ON STRAIGHT TIME, OVERTIME WILL NOT BE COVERED.

Service Calls

Contact our factory to obtain warranty service. Proluxe must issue a return authorization number, and call tag, or find the name and location of a Factory Authorized Service Center nearest you. When calling for service, please furnish the model number, serial number, and a description of the problem.

EXCLUSIONS

The warranties provided by Proluxe DO NOT apply to the following:

- Damage due to misuse, abuse, alteration, or accident.
- Improper or unauthorized repairs.
- Submerged in water.

- Damaged in shipment.
- Equipment exported to foreign countries.

Special Order Equipment and Accessories

Cannot be canceled and are not returnable unless defective within the terms of this warranty.

In no event shall Proluxe be liable for consequential damages arising out of the failure of any of its products if operated improperly or caused by normal wear or damaged by operator abuse.

Limited Lifetime Warranty on Heating Elements

If replacement is needed, Proluxe will send the new part at no charge but labor will not be covered unless the unit is still under the 1 year manufacturer warranty.

RETURNED MERCHANDISE POLICY

Should it become necessary to return any of the company's products, the following instructions must be adhered to: First, contact our customer service department for approval and a return authorization number. Please have the serial number of your item available at that time. All merchandise must be shipped freight prepaid by customer or service agency. Subject to the inspection of the product by the company, a restocking charge of 20% of the Net purchased price paid to Proluxe will be assessed.

Merchandise may not be returned for credit without prior written approval of Proluxe.

Collect shipments will not be accepted. No returns after 60 days of original shipment date on machines. Purchased parts may not be returned after 30 days. If upon inspection by Proluxe or its authorized agent it is determined the equipment has not been used in an appropriate manner, has been modified, or has not been properly maintained, or has been subject to misuse, misapplication, neglect, abuse, accident, unauthorized modification, damage during transit, delivery, fire, flood, act or war, riot or act of God, then this warranty shall be deemed null and void.

TERMS & CONDITIONS

1. Price List prices are suggested retail prices and are shown in U.S. Dollars.

2. Terms of Payment: 1% 10 days, NET 30 days.

3. New Accounts: Satisfactory credit information must be provided before open account status can be extended.

Unless agreed otherwise, all shipments will be made C.O.D., Cash in advance.

4. Pricing: Prices, specifications, model numbers, capacities and accessories are subject to change without notice.

5. Freight/Routing: Method of shipment will be determined by Proluxe unless otherwise advised by purchaser.

6. Damaged Claims: All merchandise shipped at purchaser's risk. Inspection must be made by purchaser at time goods are received. If goods are damaged, the PURCHASER shall request that the agent of the transportation company make a written notation on the proper shipping documents immediately and then file a claim for damages.

Note: Goods damaged in shipping are non-returnable.

7. Returns: Machines may not be returned after 60 days. Purchased parts may not be returned after 30 days. A restocking fee of 20% will be assessed on non-warranty returns.

8. Taxes: Prices indicated herein DO NOT include State, Federal, Local or foreign taxes or duties, nor do they include fees, permits, insurance or other levies, all of which are the responsibility of the purchaser.

9. All orders are subject to acceptance by Proluxe.

10. Possession of this price list shall not be considered an offer to sell