

Operations Manual

Endurance X1M Manual Dough Press w/ Mold - Model #: DP1100M



PROLUXE

WWW.PROLUXE.COM

Version: 101417

Congratulations!

Your selection of the Doughpro DP1100 is a sound business decision. Doughpro equipment is a result of the highest quality engineering and time-tested design. Your machine, combined with Doughpro's reputation of innovation in dough press equipment manufacturing, insures the continuing capability of delivering the best-decorated product possible.

This manual describes installation, operation, and maintenance procedures for your new model DP1100.

Your model DP1100 machine will have a long and trouble-free life. Read this manual carefully and keep it with your machine; it's your key to proper operation and lasting service.

Included with your shipment:

- One set of Rubber Feet

Installation

DOMESTIC

Use a separate 15 amp AC circuit. Only industrial extension cords with proper wire size should be used; size 16/3 wire for distance up to 25 feet, and size 14/3 for distance up to 50 feet.



INTERNATIONAL

Use a designated 16 amp AC circuit. Only industrial extension cords with proper wire size (2.5 sq. mm) shall be used.



Make sure there is a proper electrical wall outlet located within reach of the

cord and plug attached to the press. Then place the press in an area that allows for "swing clearance". The lower platen of the press requires room in which to rotate and we suggest that you allow at least 36" (91.44cm) of unobstructed space in front of the press as shown below.

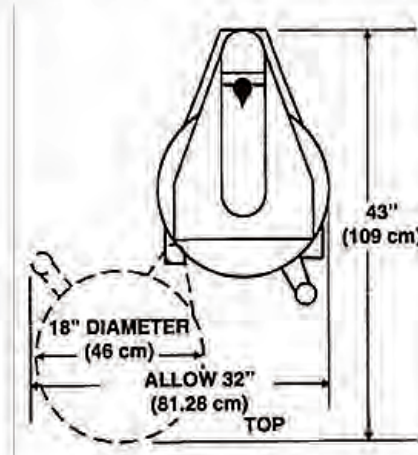

Limited Machine Warranty

Doughpro warrants this dough press machine, when operated under normal conditions, to be free from manufacturing defects in material and workmanship for a period of one year on parts and labor from the invoice date.

This warranty will be effective only when Doughpro authorizes the original purchaser to return the product to the factory in Perris California freight prepaid and only when the product, upon examination, has proven to be defective.

This warranty does not apply to any machine that has been subjected to misuse, negligence or accident.

Doughpro shall not be liable for the injury, loss or damage, direct or

consequential, arising out of the use or the inability to use the product.

No claim of any kind shall be greater in amount than the sale price of the product or part to which claim is made.

This is the sole warranty given by the company, it is in lieu of any other warranties, expressed or implied, in law or in fact, including the warranties of merchantability and fitness for a particular use, and is accepted such by the purchaser in taking delivery of this product.

Specifications

Electrical:

120V/60Hz/1425W/11.9 Amps

Also available; specify when ordering:

240V/50-60Hz/1425W/5.93Amps

Includes 72" cord and approved plug.

Shipping Weight:

190 lbs. (79 kgs.)

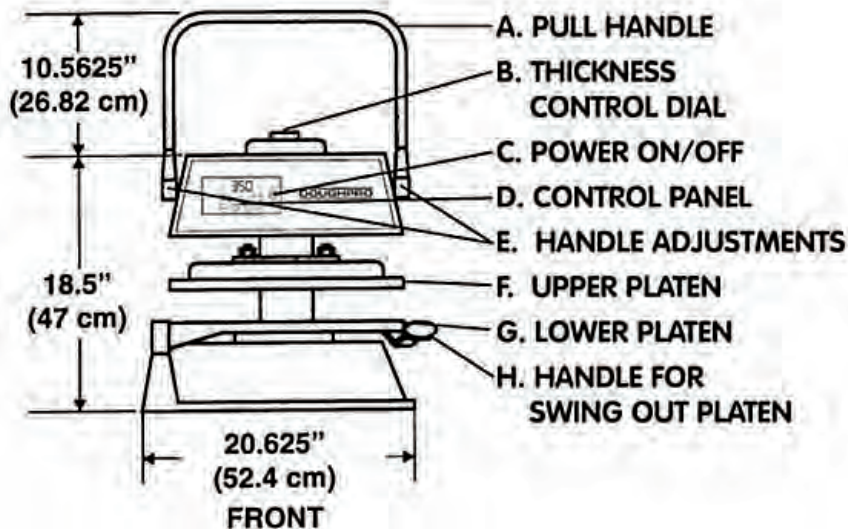

Familiarize yourself with controls and operating mechanisms before attempting to use the DP1100. These are as follows:

- (A) Pull-Down Pressing Handle for raising and lowering the upper platen. This action forces the mating of the platens.
- (B) Thickness Control Dial.
- (C) On/Off Button. The green light above the button will illuminate when turned on to indicate power is in the press.
- (D) Control Panel (*see Control Board Operations*)
- (E) Handle Adjustments (*see Tightening the Pull-Down Handle*)
- (F) Upper Platen
- (G) Lower Platen
- (H) Handle for swing out (lower) platen.

Safety Summary



WARNING

In case of power cord damage, do not attempt to repair or replace the power cord. Contact the manufacturer or the local distributor.



WARNING

Avoid touching hot surfaces while operating the machine.



CAUTION

During normal operation, the base of the machine must be installed or placed above the wall socket.



CAUTION

When servicing or cleaning the machine, make sure that the power cord is removed from the wall socket.

Control Board Operations

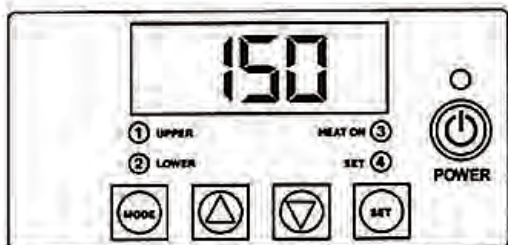

Solid State Controller

This controller has three (3) control features:

1. Temperature – Temperature may be set from 100°-450°F (38°-232°C). The factory default setting is 150°F. If you would like to change this setting, simply follow the *Controller Operation* directions.

2. Counter – Cycle counter counts the number of applications from 1 to 9999 (*see additional Notes – Counter*).

3. **Count down Timer** - Press **Mode** button until timer is displayed.

Push and hold **Set** button and simultaneously push **UP** or **DOWN** arrow buttons to desired time setting.

Controller Operation

Temperature Control

1. Press the **MODE** button until temperature is displayed.
2. Push and hold **SET** button and simultaneously push **UP** (▲) or **DOWN** (▼) arrow buttons to the desired temperature setting.

Time Control (Optional)

Please call 1-800-624-6717 if required.

Dough Pressing Operations

SETTING CRUST THICKNESS CONTROL:

Setting crust thickness is as simple as the twist of a dial. The thickness adjustment dial can be located on the top of the DP1100. By means of trial and error, rotate the dial until desired thickness is obtained. **Note: Never force the dial past its stop position or damage could occur.**

PRESSING DOUGH:

For best results, your dough should be proofed before pressing, but it will also press directly out of your refrigerator.

Flour is not required to press a crust and should not be dusted on any part of the machine.

1. First make sure you have the correct type electrical current or serious damage could occur!
2. Press the Power Button in order to turn the machine on. A green light will illuminate above the power button indicating that power is in the machine.
3. Set your desired temperature on the control panel by using the instructions as stated above. We recommend a pressing heat of 150°F but, by simple trial and error, you may desire a different setting.

Note: Heat potential is provided in the upper platen only for purposes of enabling the dough to flow more rapidly in the pressing cycle. The heat is not intended for baking.

4. Set the thickness control which is located on top of the machine. Once you have pressed a few dough balls, you can adjust this control to suit your requirements accordingly.
5. Swing open the lower platen and apply a quick spray of a good *water based* food release to the lower platen.

6. Place your pre-portioned ball of dough in the approximate center of the lower platen. Add another dash of spray to the top of the dough ball.
7. Close the platen and pull the “U” shaped handle down to commence the pressing operation.
8. Hold the handle down for as long as you have determined to be the appropriate amount of time for your particular product and then simply pull the handle back up when you have completed.
9. Inspect your dough. If it is too thick, rotate the thickness control dial, located on the top of the machine, to the line marked “THIN”. Reverse this procedure if your product presses too thin. Experiment with temperature, dough weight, time, and pressure until you arrive at the desired result.

Note: Increasing the dough portion results in a thicker product while reducing it produces a thinner product. Adding additional heat will also contribute to thinner crusts.

10. Remove the finished product by rotating the lower platen until you have sufficient space to

remove your dough. Place the dough on a screen or in a pan. *Since the shape of the dough may be altered slightly in the transfer process, some hand fitting may be required.* Add toppings, if desired, and now you are ready to bake.

ADDITIONAL NOTES:

Temperature

Note
Fahrenheit/Centigrade (Celsius) Conversion
*The temperature controller can be programmed to display either °F or °C. To change: Press the **MODE** button until the temperature is displayed, then push and hold the **SET** button for 10 seconds.*



Counter

The controller has a built in cycle counter.

- Press MODE button until the counter is displayed.
- Counter display range is 0000 to 9999.
- To reset the cycle counter, display the counter reading, then push and hold both UP (▲) and DOWN (▼) arrow buttons for 3 seconds until the counter resets to zero (0000) on the display.

Tightening the Pull-Down Handle

The pull-down pressing handle requires adjustment periodically to prevent it from free falling. Whenever the handle seems too loose or is falling by itself, the problem can be corrected easily and quickly as follows:

1. Using a 3/16" hex shaped Allen wrench, insert in key slot located on the right ***beneath*** the upper shroud.
2. Tighten until the press action of the handle becomes firm but not too tight.

Serial Tag



Domestic Tag



CE Serial Tag



DP1100 Recommended Seasoning/Cleaning Procedures

DO NOT use ice or cold water to cool unit down.

This causes the platens to warp.

Cleaning must be done daily.

TOOLS REQUIRED: 1. Food Release 2. Soapy water solution 3. Damp Washcloth 4. Paper towels



1. Season lower platen with approved food release. "Doughpro Spray"



2. Wipe oil across lower platen with paper towel



3. Wipe oil across upper platen.



4. Before cleaning make sure to turn unit off.



5. Use warm soapy water. "Use mild dish soap detergent."



6. Soak cloth and wring out.



7. Clean lower platen with damp cloth.



8. Clean upper platen with damp cloth.

International Symbols



Power Off



Power On



Hot Surface



Risk of Electrical Shock



Protective Earth Terminal



Caution - Warning

Preventative Maintenance Suggestions

The Doughpro DP1100 machines are relatively maintenance free. For a long and trouble-free life, the following preventative maintenance should be followed:

Daily Care:

1. **Platens:** These platens should *only* be cleaned with mild soap and warm water then wiped off with a clean, soft cloth or soft sponge. Never use steel wool or harsh abrasives or you will cause costly damage.
2. **All other exterior surfaces:** Here again a daily wipe down with mild soap and warm water will do the job quite nicely.

Never use steel wool or harsh abrasives or you will cause costly damage.

Piston Maintenance:

In order to ensure proper and trouble free operation of the press piston, it is important that the machine be lubricated once every three (3) months, under normal operation. High volume users may require more frequent lubrication.

The lubricant used must be USDA H-1 authorized for food machinery. This lubricant can be ordered through Doughpro/Proprocess Corporation as part number # 110-002. Please follow these simple instructions:

1. Locate the grease port on the machine. Machines with pull down arms have a single grease port located below the upper head on the right side of the vertical post. Machines with swing-away upper heads have two grease ports; one on the right side of the vertical post and one on the back of the vertical post. All other machines have a single port. (refer to illustration)
2. Place grease gun head against grease port and apply enough pressure to allow gun head to engage the grease port.
3. Squeeze handle of grease gun. This will force the grease into the piston. **One squeeze is all it takes.**

Service Problems:

Contact our factory or approved service agency (U.S. only). *Note: When contacting factory for information, parts or service instructions, it is of the utmost importance that the serial number of the machine be provided. This number can be found on the serial plate located on the rear of the machine.*

Note: Your Doughpro is equipped with a set of rubber mounting pads.

If you would prefer a set of legs which would raise your machine off the table about 4", please advise us and we will send you a set at no charge. You simply pay the UPS charge.



DOUGHPRO DP1100 Trouble Shooting Guide

Symptom	Probable Cause	Action to be Taken
Power Button on Digital Controller face is depressed but doesn't turn on.	Power Cord is not plugged in.	Plug power cord into wall 's receptacle and depress power button on controller
	Circuit Breaker is tripped off in the site's breaker box	Reset circuit breaker that the Grill is plugged into. Depress Power Button to turn on.
	Transformer has taken a electrical surge and is damaged	Replace Transformer after you check secondary side of transformer. If working properly, you should receive 12vdc.
	Check voltage on the secondary side of the Transformer. If you read 12VDC then you are receiving voltage to the Controller.	Replace Controller. Controller should be on once the power button is depressed.
	Possibly blown Fuse	Replace fuse.
Digital Controller's LED's are scrambled or randomly erratic. If when turning on, the display will first go to segment check	Possibly a componet on the Digital Controller is damaged	Replace Digital Controller
	Possibly control needs to reset	While unit is on (controller lit up) Unplug unit, wait for 1 min. then plug machine on and depress power button.
Digital Controller on startup goes through LED segment check (8888) then to version # and then loops back to to the above reboot.	The relay driver on the digital control may be blown.	Replace Digital Controller.
Digital display shows PROB. No heat on Upper Platen.	Sensor lost it's continuity as shown on a muti-meter.	Disconnect prob that is open (no continuity as shown on a multi-meter. Must replace Sensor (RTD). Do not cut and splice new sensor. Install new 2000 ohm RTD sensor to under side of Heat Platen and reconnect to Controller.
When depressing the tactile button on Digital Controller, nothing happens.	The tactile buttons under the overlay may be not close enough to activate. Same goes if the buttons are already pressed by overlay without depressing button.	Carefully (no too much at one time to avoid fracturing the traces on the Controller) tighten the nuts on the back of the Controller until button activate. Same goes in reverse if buttons are held down by the overlay.
Digital display shows Relay and Particular zone is over heating or outer zone).	The Relay on the switched side is not opening to regulate temperature.	Replace the Relay.
Beeper not functioning or intermitten beeper sound.	Beeper on Digital Control board failed.	Replace Digital Controller board
If setpoint is reached but slighty off in temperature.	Offset may need to be calibrated and adjusted.	Must call (800) 624-6717 ext. 129 for confidential instructions.

DOUGHPRO DP1100 Trouble Shooting Guide

Symptom	Probable Cause	Action to be Taken
Heater Platen overheating	If the Relay (depending the year of the model) on the coil side are receiving 12vdc indicates the Controller is functioning properly. On the switching side of the relay, is there 120 vac going to the heater in question . If there is no voltage on the to the switching side of the relay to the heaters, the Relay is not working properly	Replace Relay If the Controller's heat-on LED is not lit indicating the controller is working properly.
Dough not having same thickness across the press dough.	To adjust upper platen for level press	Underneath the arm resting on the Upper Platen Shroud you will find 4, stacked hex bolts sitting over the upper platen attach to the arm. The top bolts are called locking bolts. The 4 larger Hex Bolts below are Adjustment Bolts. Break free the 4 Locking blts. With a open end wrench adjust the A. bolts (1/8 turn at a time where needed and test with dough. After satisfied, tighten the Locking bolts making sure not to move the larger Adustment Bolts.

PROLUXE

DP1100M EXPLOSION VIEW

MASTER COPY
Date 06/01/18

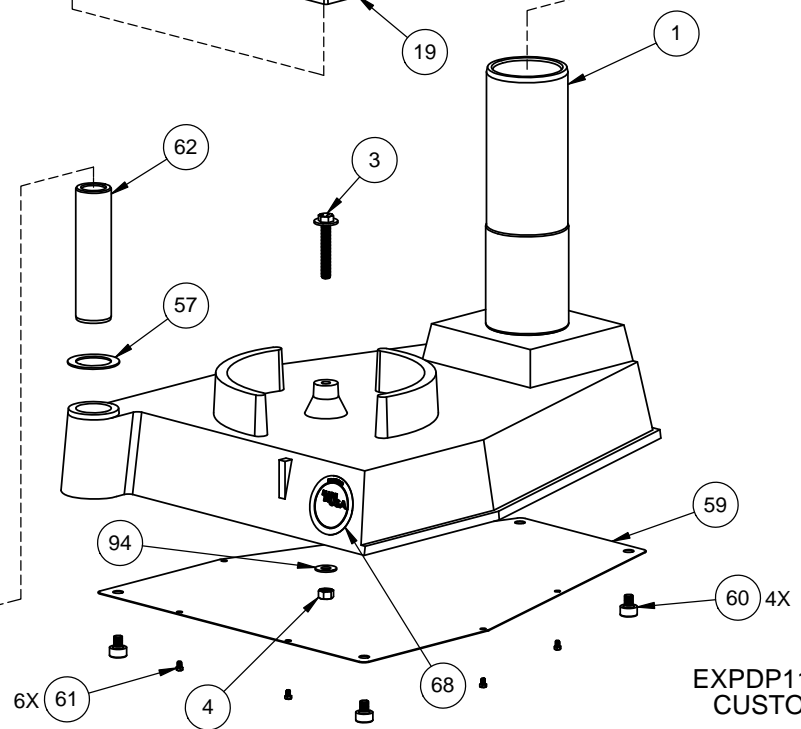
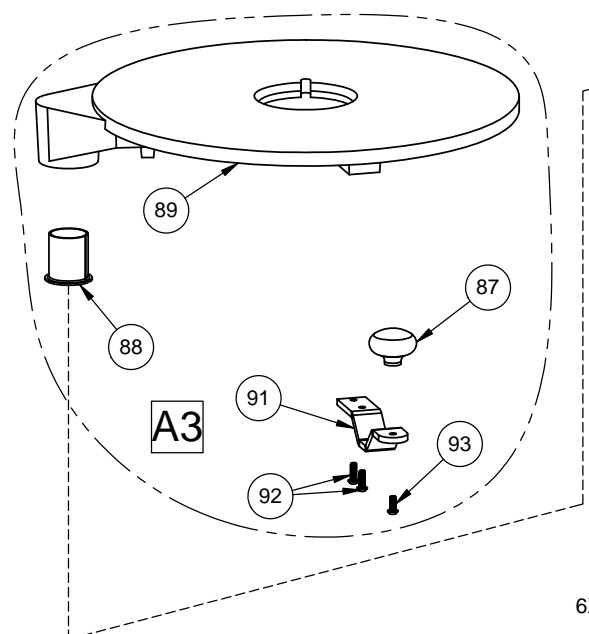
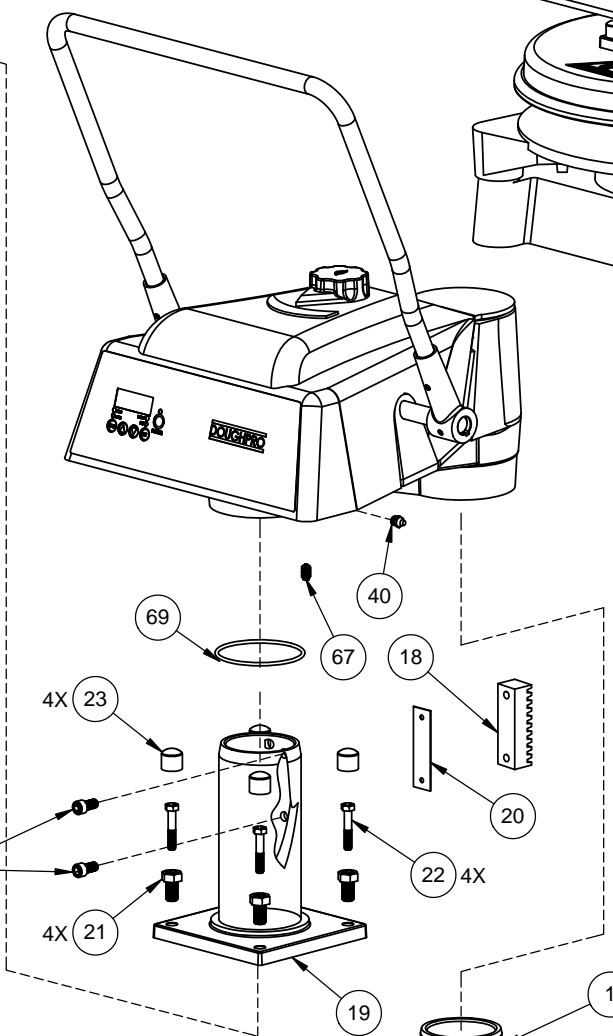
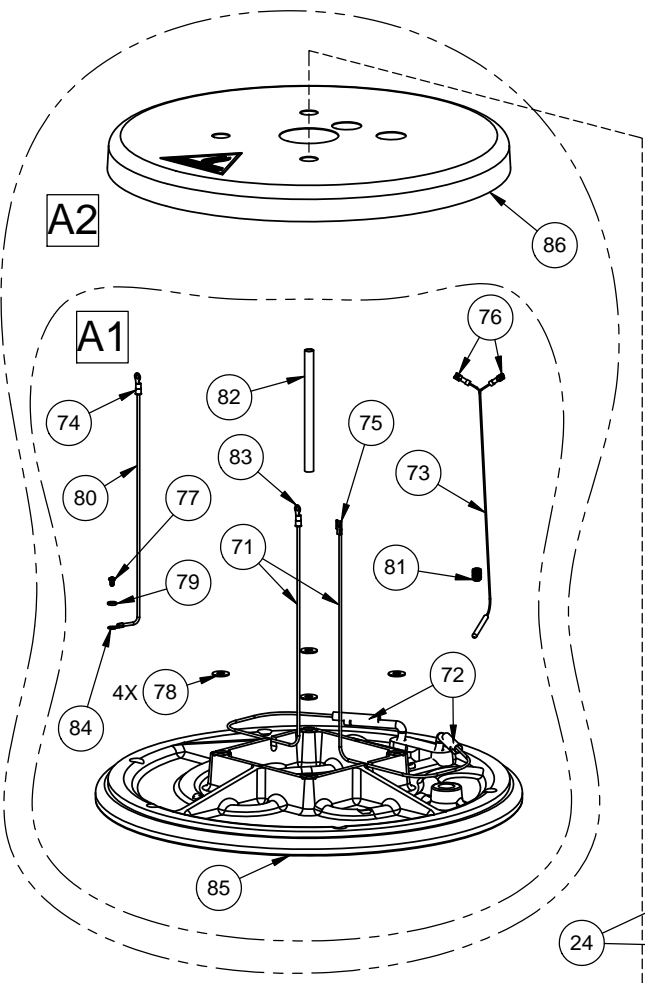
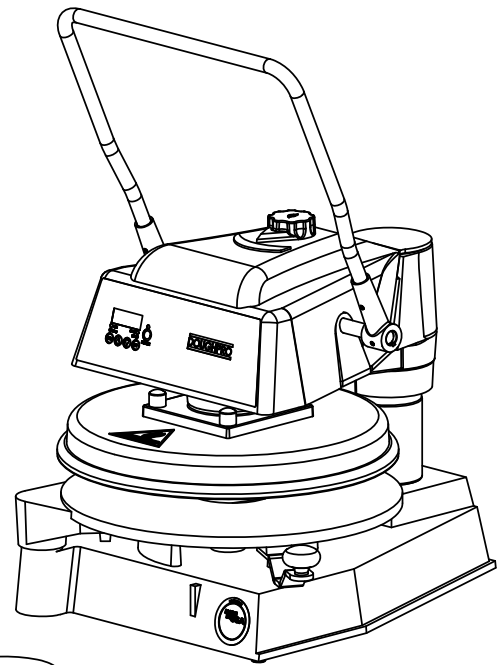

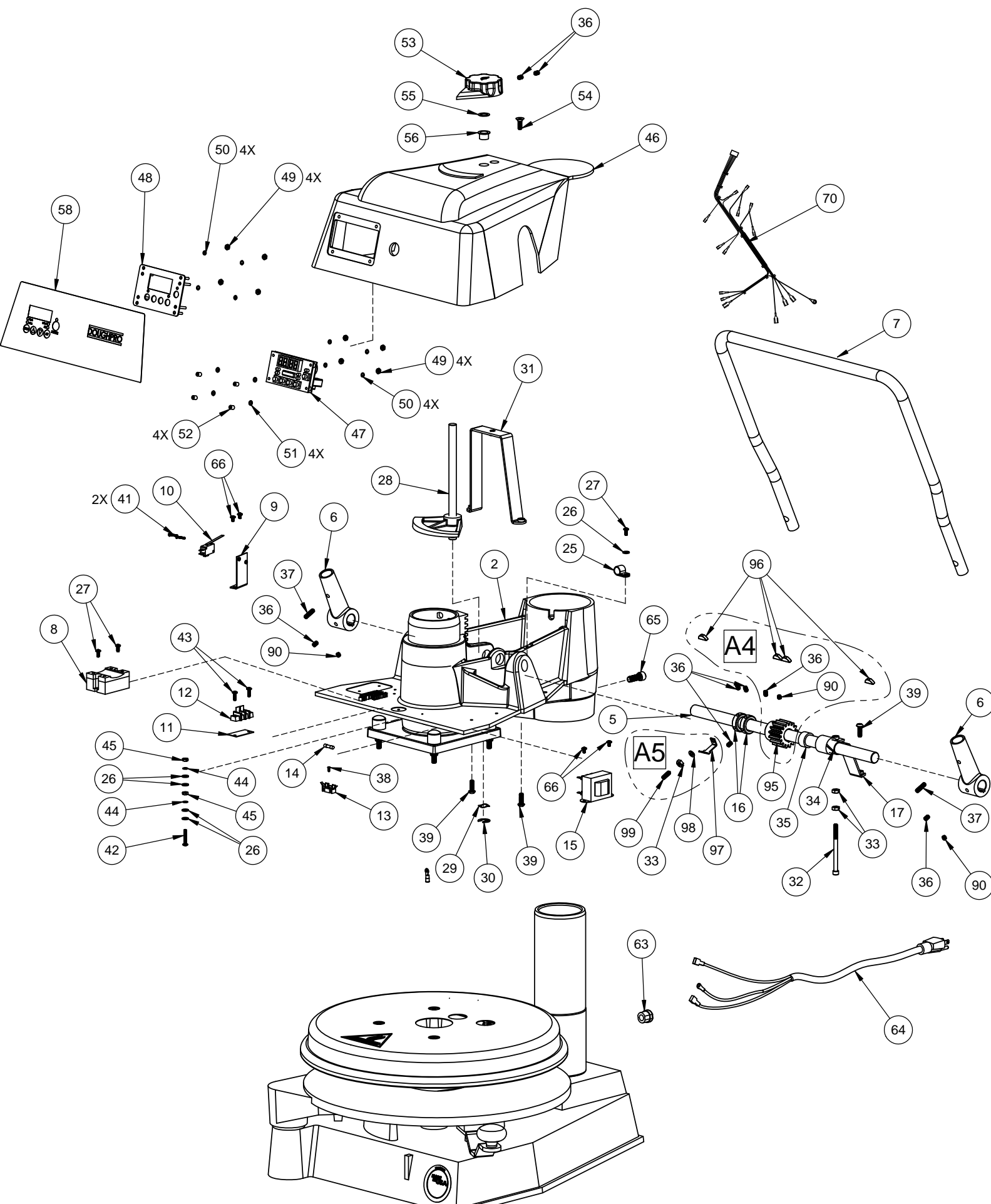

PROLUXE PARTS LIST FOR MODEL

DP1100M

ITEM NO.	DESCRIPTION	DP1100MA 120 ~ AC	DP1100MB 240 ~ AC	DP1100MGB 240 ~ AC	DP1100MCEB 240 ~ AC	DP1100MCEC 220 ~ AC	QTY.
1	BASE ASSEMBLY	110931101	110931101	110931101	110931101	110931101	1
2	ARM MACHINED	11010212101	11010212101	11010212101	11010212101	11010212101	1
3	LOWER PLATEN STOP, ASSEMBLY	110102130	110102130	110102130	110102130	110102130	1
4	NUT, HEX 3/8-16	NH3816	NH3816	NH3816	NH3816	NH3816	1
5	GEAR BAR	1109361	1109361	1109361	1109361	1109361	1
6	HANDLE SOCKET	11016650	11016650	11016650	11016650	11016650	2
7	HANDLE, PRESSURE	1109390	1109390	1109390	1109390	1109390	1
8	RELAY, SOLID STATE	MPR90217	MPR90217	MPR90217	MPR90217	MPR90217	1
9	MICROSWITCH BRACKET	1101021213	1101021213	1101021213	1101021213	1101021213	1
10	MICRO SWITCH	V15G31C25K	V15G31C25K	V15G31C25K	V15G31C25K	V15G31C25K	1
11	MARKER STRIP #2	MS6992	MS6992	MS6992	MS6992	MS6992	1
12	BLOCK, TERMINAL ASSY 2 STAGE	11096914	11096914	11096914	11096914	11096914	1
13	FUSE HOLDER 1 AMP	MPPF708	MPPF708	MPPF708	MPPF708	MPPF708	1
14	FUSE BUSS 1 AMP	MPPF701R	MPPF701R	MPPF701R	MPPF701R	MPPF701R	1
15	TRANSFORMER	11096975	11096975	11096975	11096975	11096975	1
16	COLLAR, GEAR BAR	11013183	11013183	11013183	11013183	11013183	2
17	ASSEMBLY, TENSION STRAP	11041663	11041663	11041663	11041663	11041663	1
18	RACK, GEAR	1109380	1109380	1109380	1109380	1109380	1
19	ASSEMBLY, PISTON	11018974	11018974	11018974	11018974	11018974	1
20	SHIM, GEAR RACK	110144120	110144120	110144120	110144120	110144120	1
21	BOLT, LEVEL ADJUSTMENT	1109367	1109367	1109367	1109367	1109367	4
22	BOLT, HEX 5/16-18 X 1 3/4" GR5	BH51618134G5	BH51618134G5	BH51618134G5	BH51618134G5	BH51618134G5	4
23	CAP, VINYL (ADJUSTMENT SCREWS)	SC0687	SC0687	SC0687	SC0687	SC0687	4
24	SCREW, SOCKET HEAD 3/8-16 X 3/4	SSH381634	SSH381634	SSH381634	SSH381634	SSH381634	2
25	CLAMP, CABLE 3/8	CC38	CC38	CC38	CC38	CC38	1
26	WASHER, SAE #8	WSAE8	WSAE8	WSAE8	WSAE8	WSAE8	5
27	SCREW, PHILLIPS PAN HEAD 8-32 X 3/8	SP83238	SP83238	SP83238	SP83238	SP83238	3
28	CAM RAMP ASSEMBLY	1109310	1109310	1109310	1109310	1109310	1
29	WASHER, WAVE .505 I.DX.750 O.D., X .045	5806282	5806282	5806282	5806282	5806282	1
30	CLIP "E" RETAINING 1/2	MPSC240	MPSC240	MPSC240	MPSC240	MPSC240	1
31	BRACKET, HOUSING ASSEMBLY	110144130	110144130	110144130	110144130	110144130	1
32	SCREW, SOCKET HEAD 1/4-20 X 3 1/4	SSH1420314	SSH1420314	SSH1420314	SSH1420314	SSH1420314	1
33	NUT, HEX 1/4-20	NH1420	NH1420	NH1420	NH1420	NH1420	3
34	BUSHING, TENSION STRAP	11018966	11018966	11018966	11018966	11018966	1
35	BUSHING, SPACER	11024369	11024369	11024369	11024369	11024369	1
36	SCREW, SET 1/4-20 X 3/8	SST142038	SST142038	SST142038	SST142038	SST142038	6
37	SCREW, SET SOCKET HEAD 1/4-20 X 7/8	SST142078	SST142078	SST142078	SST142078	SST142078	2
38	SCREW, PHILLIPS PAN 2-56 X 1/4	SP25614	SP25614	SP25614	SP25614	SP25614	1
39	SCREW, BUTTON HEAD 1/4-20X3/4	SB142034	SB142034	SB142034	SB142034	SB142034	3
40	FITTING, ZERK 1/4-28	B792	B792	B792	B792	B792	1
41	SCREW, ROUND HEAD 4-40 X 5/8 SLOTTED	SR44058	SR44058	SR44058	SR44058	SR44058	2
42	SCREW, PAN HEAD 8-32 X 1	SP8321	SP8321	SP8321	SP8321	SP8321	1
43	SCREW, PAN HEAD PHILLIPS 8-32 X 1/2	SP83212	SP83212	SP83212	SP83212	SP83212	2
44	WASHER, INTERNAL TOOTH LOCK #8	WLIT8	WLIT8	WLIT8	WLIT8	WLIT8	2
45	NUT, HEX 8-32	NH832	NH832	NH832	NH832	NH832	2
46	HOUSING MACHINED	1101781542201	1101781542201	1101781542201	1101781542201	1101781542201	1
47	DIGITAL CONTROL	11096905211	11096905211	11096905211	11096905211	11096905211	1
48	ASSEMBLY, CONTROL FACIA	11086027	11086027	11086027	11086027	11086027	1
49	NUT, HEX 6-32	NH632	NH632	NH632	NH632	NH632	8
50	WASHER, INTERNAL TOOTH LOCK #6	WLIT6	WLIT6	WLIT6	WLIT6	WLIT6	8
51	WASHER, STEEL	311150019	311150019	311150019	311150019	311150019	4
52	NYLON SPACER, 1/4 X .141 X 9/32 LONG	110969111	110969111	110969111	110969111	110969111	4
53	KNOB, THICK/THIN MACHINED	1109309	1109309	1109309	1109309	1109309	1
54	SCREW, SOCKET FLAT HEAD 1/4-20 X 3/4	SF142034	SF142034	SF142034	SF142034	SF142034	1

PROLUXE PARTS LIST FOR MODEL

DP1100M

ITEM NO.	DESCRIPTION	DP1100MA 120 ~ AC	DP1100MB 240 ~ AC	DP1100MGB 240 ~ AC	DP1100MCEB 240 ~ AC	DP1100MCEC 220 ~ AC	QTY.
55	SHIM WASHER	WS12031	WS12031	WS12031	WS12031	WS12031	1
56	BUSHING, FLANGE	212NN01420000	212NN01420000	212NN01420000	212NN01420000	212NN01420000	1
57	SHIM, LOWER PLATEN	110379322055	110379322055	110379322055	110379322055	110379322055	1
58	OVERLAY, DIGITAL CONTROL PANEL	ODP1100	ODP1100	ODP1100	ODP1100	ODP1100	1
59	COVER PLATE, BASE	11010954	11010954	11010954	11010954	11010954	1
60	FEET, RUBBER	RF209	RF209	RF209	RF209	RF209	4
61	BOLT, HEX 8-32 X 1/4	BH83214	BH83214	BH83214	BH83214	BH83214	6
62	POST, LOWER PLATEN	11015960	11015960	11015960	11015960	11015960	1
63	CABLE STRAIN RELIEF	MPSS168	MPSS168	MPSS168	MPSS168	MPSS168	1
64	POWER CORD	110969174	110969175	DP149203	MPPW202	MPPW202	1
65	SCREW, SOCKET HEAD 3/8-16 X 1	SSH38161	SSH38161	SSH38161	SSH38161	SSH38161	1
66	SCREW, PHILLIPS PAN HEAD 8-32 X 1/4	SP83214	SP83214	SP83214	SP83214	SP83214	4
67	DETENT, PLUNGER SPRING 3/8-16	MPSP134	MPSP134	MPSP134	MPSP134	MPSP134	1
68	DECAL USA STICKER	DPROUSA	DPROUSA	DPROUSA	DPROUSA	DPROUSA	1
69	ORING, #2-28 N-70, PISTON	238N70	238N70	238N70	238N70	238N70	1
70	WIRE HARNESS	110560051	110560051	110560051	110560051	110560051	1
71	WIRE, TGGT, 14GA. (HEATER)	110069	110069	110069	110069	110069	7 FT.
72	TFE SHRINK TUBING	110131	110131	110131	110131	110131	.33 FT.
73	SENSOR ASSEMBLY	110949110	110949110	110949110	110949110	110949110	1
74	TERMINAL, RING #8	1604	1604	1604	1604	1604	1
75	14-16 GA #10 FORK TERMINAL INSUL.	1626	1626	1626	1626	1626	1
76	TERMINAL Q.D. 3/16 X 18/22GA.	2280	2280	2280	2280	2280	2
77	SCREW, PAN HEAD 6-32 X 1/4	SP63214	SP63214	SP63214	SP63214	SP63214	1
78	WASHER, SAE 5/16	WSAE516	WSAE516	WSAE516	WSAE516	WSAE516	4
79	WASHER, SAE #6	WSAE6	WSAE6	WSAE6	WSAE6	WSAE6	1
80	WIRE, TFE 14GA. GREEN	WTFE14G	WTFE14G	WTFE14G	WTFE14G	WTFE14G	3.08 FT.
81	SCREW, SET 3/8-16 X 1/2	SST381612	SST381612	SST381612	SST381612	SST381612	1
82	SLEEVEING, PVC WIRE	OPVC1050	OPVC1050	OPVC1050	OPVC1050	OPVC1050	1.33 FT.
83	TERMINAL, FEMALE MOLEX	MPSQ100	MPSQ100	MPSQ100	MPSQ100	MPSQ100	1
84	TERMINAL, RING #6	1601HT	1601HT	1601HT	1601HT	1601HT	1
86	SHROUD, UPPER PLATEN	1109336	1109336	1109336	1109336	1109336	1
87	KNOB, SWING AWAY	110017	110017	110017	110017	110017	1
88	FLANGED BUSHING MACHINED	110102167	110102167	110102167	110102167	110102167	1
90	SCREW, SET 1/4-20 X 1/4"	SST142014	SST142014	SST142014	SST142014	SST142014	3
91	HANDLE LOWER PLATEN	1106301	1106301	1106301	1106301	1106301	1
92	SCREW, BUTTON HEAD 1/4-20 X 3/4	SB142034	SB142034	SB142034	SB142034	SB142034	2
93	SCREW, BUTTON HEAD 1/4-20 X 5/8	SB142058	SB142058	SB142058	SB142058	SB142058	1
94	WASHER, SAE 3/8	WSAE38	WSAE38	WSAE38	WSAE38	WSAE38	1
95	PINION GEAR ASSEMBLY	1109360	1109360	1109360	1109360	1109360	1
96	KEYWAY, #9 3/16 X 3/4	KW931634	KW931634	KW931634	KW931634	KW931634	4
97	BRACKET, MICRO SWITCH	110200019	110200019	110200019	110200019	110200019	1
98	WASHER, SPLIT LOCK, 1/4	WL14	WL14	WL14	WL14	WL14	1
99	SCREW, SET 1/4-20 X 3/4 CONE POINT	SST142034CP	SST142034CP	SST142034CP	SST142034CP	SST142034CP	1
100	MANUAL DP1100M	MDP1100M	MDP1100M	MDP1100M	MDP1100M	MDP1100M	1
A1	UPPER PLATEN WIRE ONLY	110074120K	110074240K	110074240K	110074240K	110074220K	1
A2	UPPER PLATEN COMPLETE ASSEMBLY	110074120AK	110074240AK	110074240AK	110074240AK	110074220AK	1
A3	LOWER PLATEN ASSEMBLY	11076632K	11076632K	11076632K	11076632K	11076632K	1
A4	PINION GEAR ASSEMBLY	1109360K	1109360K	1109360K	1109360K	1109360K	1
A5	KIT, MICRO SWITCH BRACKET ASSEMBLY	110200019K	110200019K	110200019K	110200019K	110200019K	1

PROLUXE

Warranty & Return Policy

Proluxe warrants all products manufactured by it against defects in workmanship or materials from the date of purchase for a period of (1) year on parts and labor. **This warranty applies to only equipment purchased and used in the United States.** Warranty period shall begin when equipment ships. Warranty travel shall only be covered for 60 miles. Limited lifetime warranty on heating elements.

ALL WARRANTY SERVICE CALLS MUST BE APPROVED BY PROLUXE. IF THIS PROCEDURE IS NOT FOLLOWED, WARRANTY SERVICE WILL NOT BE COVERED. WARRANTY SERVICE WILL BE PAID ON STRAIGHT TIME, OVERTIME WILL NOT BE COVERED.

Exclusions:

- 1. WOOD / GAS FIRED OVENS:** PROLUXE warranty applies to the main body of the oven being steel / refractory and insulation shall be free from defects in materials and workmanship for a period of four years from the date of purchase. The gas equipment shall be free from defects in materials and workmanship for a period of one (1) year from the date of purchase. Lifetime warranty against cracks on oven floor.
- 2. Air compressors are excluded from this warranty,** but PROLUXE may act as a warranty expeditor in certain instances regarding these compressors. The air compressor manufacturer provides a limited warranty and a copy of this warranty is furnished with all compressors sold by PROLUXE. For prompt handling of compressor warranty claims the instructions of the compressor manufacturer must be adhered to.
- 3. Equipment built to special order as well as accessories** cannot be canceled and are not returnable unless defective within the terms of this warranty.
- 4. In no event shall PROLUXE be liable for consequential damages arising out of the failure of any of its products if operated improperly, altered or caused by normal wear or damage by operator abuse.**
- 5. BC2325 pedestal warranty disclaimer:** Pedestals shall only be covered under warranty if they have been cleaned using the factory approved cleaning method. Cracked or damaged pedestals must be inspected by the factory before warranty is authorized.
- 6. Limited lifetime warranty on heating elements:** If replacement is needed, Proluxe will send the new part at no charge but labor will not be covered unless the unit is still under the 1 year manufacture warranty.

Returned Merchandise Policy:

Should it become necessary to return any of the company's products, the following instructions must be adhered to: First, contact our customer service department for approval and a return authorization number. *Please have the serial number of your item available at that time.* All merchandise must be shipped *freight prepaid* by customer or service agency. Subject to the inspection of the product by the company, a restocking charge of 20% of the Net purchased price paid to PROLUXE will be assessed. Merchandise may not be returned for credit without *prior written approval* of PROLUXE. Collect shipments *will not* be accepted. No returns after 60 days of original shipment date on machines. Purchased parts may not be returned after 30 days.

If upon inspection by PROLUXE or its authorized agent it is determined the equipment has not been used in an appropriate manner, has been modified, or has not been properly maintained, or has been subject to misuse, misapplication, neglect, abuse, accident, unauthorized modification, damage during transit, delivery, fire, flood, act or war, riot or act of God, then this warranty shall be deemed null and void.

Terms & Conditions:

- Prices indicated in the PRICE LIST are suggested retail prices and are shown in U.S. DOLLARS.
- Terms of Payment: NET 30 days.
- NEW ACCOUNTS:** Satisfactory credit information must be provided before open account status can be extended. Unless agreed otherwise, all shipments will be made C.O.D., CASH IN ADVANCE.
- PRICING:** Prices, specifications, model numbers, capacities and accessories are subject to change without notice.
- FREIGHT / ROUTING:** Method of shipment will be determined by PROLUXE unless otherwise advised by PURCHASER.
- DAMAGED CLAIMS:** All merchandise shipped at purchaser's risk. Inspection must be made by purchaser at time goods are received. If goods are damaged, the PURCHASER shall request that the agent of the transportation company make a written notation on the proper shipping documents immediately and then file a claim for damage. **GOODS DAMAGED IN SHIPMENT ARE NOT RETURNABLE.**
- RETURNS:** Machines may not be returned after 60 days. Purchased parts may not be returned after 30 days. A restocking fee of 20% will be assessed on non-warranty returns.
- TAXES:** Prices indicated herein DO NOT include State, Federal, Local or foreign taxes or duties, nor do they include fees, permits, insurance or other levies, all of which are the responsibility of the purchaser.
- All orders are subject to acceptance by PROLUXE.
- Possession of this price list shall not be considered an offer to sell.