

Operations Manual

Model: DP2010PIPG
Semiautomatic Dual Heat
Dough Press



DOUGHPRO



PROLUXE  TM

formerly DOUGHPRO. New Name. Same Quality. Superior Service.

proluxe.com

Congratulations!

Your selection of the Proluxe DP2010 is a sound business decision. Whether your intended use is to press or par bake dough for pizzas, tortillas, mushi skins or other appropriate dough products, rest assured that you have made a wise choice.

Proluxe equipment is a result of the highest quality engineering and time-tested design. Your machine, combined with Proluxe's reputation of innovation in dough press equipment manufacturing, insures the continuing capability of delivering the best-decorated product possible.

This manual describes installation, operation, and maintenance procedures for your new model DP2010.

Your model DP2010 machine will have a long trouble-free life. Read this manual carefully and keep it with your machine; it's your key to proper operation and lasting service.

Included with your shipment:

- 5 Rubber Feet
- Platen Saver **If your unit has polished platens**

Installation

DOMESTIC

Use a separate 30 amp AC circuit. Only industrial extension cords with proper wire size should be used; size 16/3 wire for distance up to 25 feet, and size 14/3 for distance up to 50 feet.



INTERNATIONAL

Use a designated 30 amp AC circuit. Only industrial extension cords with proper wire size (2.5 sq. mm) shall be used.



Make sure there is a proper electrical wall outlet located within reach of the cord and plug attached to the press. Then place the press in an area that allows for "swing clearance". Note that the upper platen rotates up to 90°, in a backward rotation, to facilitate removal of the dough product after the press cycle has been completed. Also note that the machine requires a vertical, clear space of 33" from the bottom of the machine to the top of the pull handle.

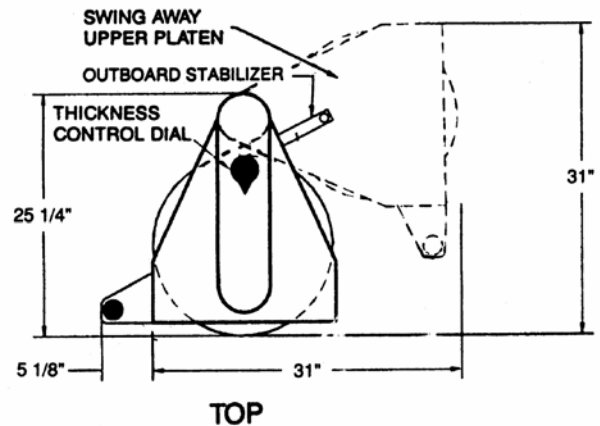

Limited Machine Warranty

Proluxe warrants this dough press machine, when operated under normal conditions, to be free from manufacturing defects in material and workmanship for a period of one year on parts and labor from the invoice date.

This warranty will be effective only when Proluxe authorizes the original purchaser to return the product to the Factory in Perris, California

prepaid and only when the product, upon examination, has proven to be defective.

This warranty does not apply to any machine that has been subjected to misuse, negligence or accident.

Proluxe shall not be liable for the injury, loss or damage, direct or consequential, arising out of the use or the inability to use the product.

No claim of any kind shall be greater in amount than the sale price of the product or part to which claim is made.

This is the sole warranty given by the company, it is in lieu of any other warranties, expressed or implied, in law or in fact, including the warranties of merchantability and fitness for a particular use, and is accepted such by the purchaser in taking delivery of this product.

Specifications

Electrical:

208V/50-60Hz/4600W/22.11Amps

Requires 30 AMP outlet

Includes 72" NEMA 6-30P approved cord and plug.

Shipping Weight:

180lbs. (82kg)

Familiarize yourself with controls and operating mechanisms before attempting to use the DP2010. These are as follows:

- (A) Pull Pressing Handle for raising and lowering the upper platen. This action forces the mating of the platens.
- (B) Lock release
- (C) On/Off Button. The green light above the button will illuminate when turned on to indicate power is in the press.
- (D) Control Panel (*see Control Board Operations*)
- (E) Handle for swing-out platen.
- (F) Upper platen
- (G) Lower platen

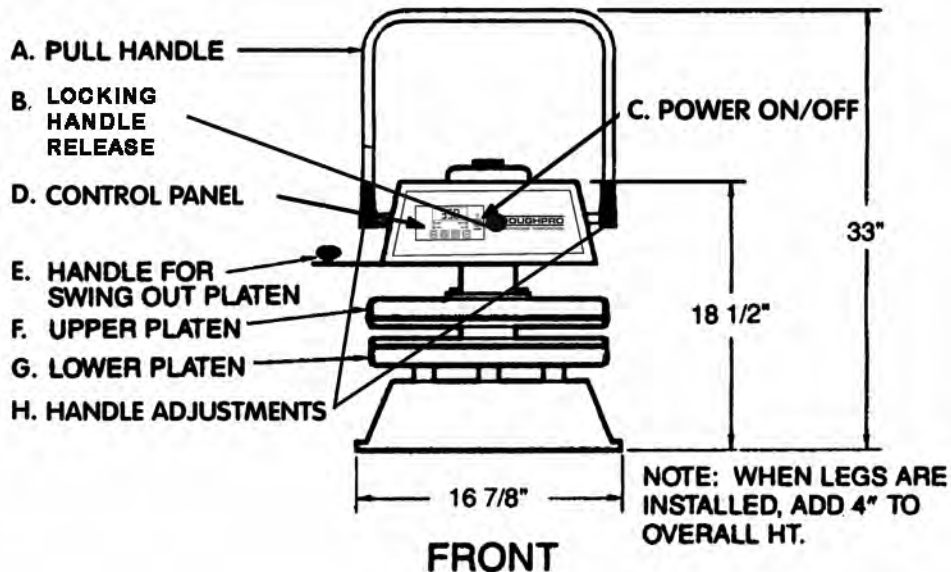



WARNING

In case of power cord damage, do not attempt to repair or replace the power cord. Contact the manufacturer or the local distributor.



WARNING

Avoid touching hot surfaces while operating the machine.



CAUTION

During normal operation, the base of the machine must be installed or placed above the wall socket.



CAUTION

When servicing or cleaning the machine, make sure that the power cord is removed from the wall socket.

Control Board Operations

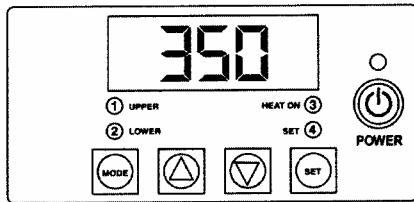

Solid State Controller

This controller has three (3) control features:

1. Temperature – Temperature may be set from 0°-450°F (0°-232°C). The factory default setting is 240°. If you would like to change this setting, simply follow the *Controller Operation* directions.

2. Counter – Cycle counter counts the number of applications from 1 to 9999 (*see additional Notes – Counter*).
3. Timer – A timer mode is available upon special request. If you would like to have the timer function installed, please call 1-800-624-6717

Controller Operation

Temperature Control

1. Press the **MODE** button until temperature is displayed.
2. Push and hold **SET** button and simultaneously push UP (▲) or DOWN (▼) arrow buttons to the desired temperature setting.

For the DP2000, both the upper and lower platen may be set to different temperatures.

- *Upper Platen:* Simply push the **MODE** button until the “upper” light is illuminated. Adjust the temperature as noted above.
- *Lower platen:* Simply push the **MODE** button until the “lower” light is illuminated. Adjust the temperature as noted above.

Dough Pressing Operations

SETTING CRUST THICKNESS CONTROL:

*The thickness is determined by dough weight and temperature setting on each platen.

| <i>Dough Product</i> | Press Only | | Press & Par Bake | |
|----------------------|-----------------------------------|-------------------|-----------------------------|-------------------|
| | <i>Temp</i> | <i>Press Time</i> | <i>Temp</i> | <i>Press Time</i> |
| Pizza | 150°F both platens | 3 seconds | 325°F both platens | 7-15 seconds |
| Flour Tortilla | N/A | | 350°F both platens | 1 quick second |
| Corn Tortilla | No heat, must use wax paper | 3 seconds | N/A | |
| Mushi Skin | 150°F both platens | 3 seconds | N/A | |

****To achieve consistent size flour tortillas of smaller than 10” you will need to only press 2 at a time as shown in the pictures included with the manual.***

Note: Keep in mind that dough formulations may differ, and that you may have to do some trial and error testing of different temperatures and platen pressure to arrive at the proper end result for your particular product.

Also note that the finished, after-pressing diameter of the finished dough piece is determined by the weight of the dough and the amount of pressure applied to the platens.

For best results, your dough should be proofed at room temperature before pressing, but it will also press directly out of your refrigerator. **Flour is not required to press a crust and should not be dusted on any part of the machine.**

PRESSING DOUGH:

1. First make sure you have the correct type electrical current or serious damage could occur!
2. Press the Power Button in order to turn the machine on. A green light will illuminate above the power button indicating that power is in the machine.
3. Both the upper and lower platens will heat up once you have adjusted your digital control to your desired setting. *Note: Different products require different temperature settings. In order to determine the right temperature setting for your product, refer to the following table simply as a guide for starting.*

ADDITIONAL NOTES:

Temperature

No. DPPC1. (See our catalog and price list for information.)

*Note: This spray **will not** affect the taste of your crust in any way.*

- Place your pre-portioned ball of dough in the approximate center of the lower platen. Add another dash of spray to the top of the dough ball.

- Close the platen and pull the “U” shaped handle down to commence the pressing operation.

- Press the handle down until the magnet has activated for the appropriate amount of time for your particular product and then the handle lock will release once the time has completed.

.....dwwqp"qp"vj g"ltqpv"qh"vj g"o cej kpg"y kni'

.....f kugpi ci g"vj g"o ci gv'r tkqt"vq"vj g"vko gt

.....gzr ktpi 0

- Remove the finished product by rotating the upper platen out of the way until you have sufficient space to do so. Place the dough on a screen or in a pan. Since the shape of the dough may be altered slightly in the transfer process, some hand fitting may be required. Add toppings, if desired, and now you are ready to bake.

Note

Fahrenheit/Centigrade (Celsius) Conversion

The temperature controller can be programmed to display either °F or °C. To change: Press the **MODE** button until the temperature is displayed, then push and hold the **SET** button for 10 seconds.



Counter

The controller has a built in cycle counter.

- Press MODE button until the counter is displayed.
- Counter display range is 0000 to 9999.
- To reset the cycle counter, display the counter reading, then push and hold both UP (▲) and DOWN (▼) arrow buttons for 3 seconds until the counter resets to zero (0000) on the display.

!Warning!

Forcing the handle up while engaged to the magnet will cause damage and is not covered under warranty.

To release the handle before the time has expired, press the black release button located right of the control.

International Symbols



Power Off



Power On



Hot Surface



Risk of Electrical Shock



Protective Earth Terminal



Ground



Caution - Warning

Serial Tags

| | | |
|---|-----------|----|
| PROPROCESS CORPORATION | | CE |
| PATENT # 6,332,768 | | |
| MODEL DP2000 | S/N 40000 | ⚠ |
| VOLTS 240 ~ | 50/60 Hz | |
| WATTS 1500 | YR. 200 | |
| COMMERCIAL COOKING APPLIANCE FACTORY: 5842 BORWICK AVE. SOUTH GATE CA. 90280 | | |

PART # SPRODP2000C

| | | |
|---|-----------|----------------------|
| PROPROCESS CORPORATION | | UL LISTED 2000 |
| PATENT # 6,332,768 | | |
| MODEL DP2000 | S/N 20000 | UL LISTED 2000 |
| VOLTS 240 ~ | 50/60 Hz | |
| WATTS 1500 | YR. 200 | |
| COMMERCIAL COOKING APPLIANCE FACTORY: 5842 BORWICK AVE. SOUTH GATE CA. 90280 | | |

PART # SPRODP2000B

| | | |
|---|-----------|----------------------|
| PROPROCESS CORPORATION | | UL LISTED 2000 |
| PATENT # 6,332,768 | | |
| MODEL DP2000 | S/N 10000 | UL LISTED 2000 |
| VOLTS 120 ~ | 50/60 Hz | |
| WATTS 1500 | YR. 200 | |
| COMMERCIAL COOKING APPLIANCE FACTORY: 5842 BORWICK AVE. SOUTH GATE CA. 90280 | | |

PART # SPRODP2000A

Preventative Maintenance Suggestions

The Proluxe DP2010 machines are relatively maintenance free. For a long and trouble-free life, the following preventative maintenance should be followed:

Daily Care:

1. **Platens:** These platens should *only* be cleaned with mild soap and warm water then wiped off with a clean, soft cloth or soft sponge. **Never use steel wool or harsh abrasives or you will cause costly damage.**
2. **All other exterior surfaces:** Here again a daily wipe down with mild soap and warm water will do the job quite nicely. **Never use steel wool or harsh abrasives or you will cause costly damage.**

Piston Maintenance:

In order to ensure proper and trouble free operation of the press piston, it is important that the machine be lubricated once every three (3) months, under normal operation. High volume users may require more frequent lubrication.

The lubricant used must be USDA H-1 authorized for food machinery. This lubricant can be ordered through Proluxe as part number # 110-002. Please follow these simple instructions:

1. Locate the grease port on the machine. Machines with pull down arms have a single grease port located below the upper head on the right side of the vertical post. Machines with swing-away upper heads have two grease ports; one on the right side of the vertical post and one on the back of the vertical post. All other machines have a single port. (refer to illustration)
2. Place grease gun head against grease port and apply enough pressure to allow gun head to engage the grease port.
3. Squeeze handle of grease gun which forces the grease into the piston. **One squeeze is all it takes.**

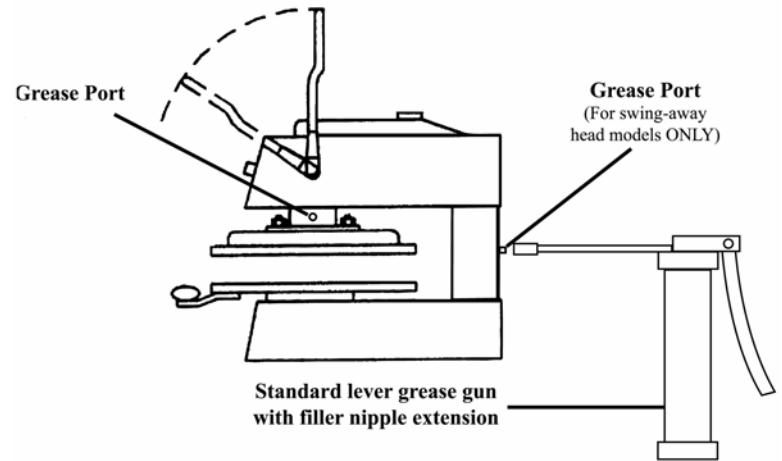

Service Problems:

Contact our factory or approved service agency (U.S. only). *Note: When contacting factory for information, parts or service instructions, it is of the **utmost importance** that the serial number of the machine be provided. This number can be found on the serial plate located on the rear of the machine.*

DOUGHPRO DP2000 Trouble Shooting Guide

| Symptom | Probable Cause | Action to be Taken |
|--|---|---|
| Power Button on Digital Controller face is depressed but doesn't turn on. | Power Cord is not plugged in. | Plug power cord into wall 's receptacle and depress power button on controller |
| | Circuit Breaker is tripped off in the site's breaker box | Reset circuit breaker that the Grill is plugged into. Depress Power Button to turn on. |
| | Transformer has taken a electrical surge and is damaged | Replace Transformer after you check secondary side of transformer. If working properly, you should receive 12vdc. |
| | Check voltage on the secondary side of the Transformer. If you read 12VDC then you are receiving voltage to the Controller. | Replace Controller. Controller should be on once the power button is depressed. |
| | Possibly blown Fuse | Replace fuse. |
| Digital Controller's LED's are scrambled or randomly erratic. If when turning on, the display will first go to segment check | Possibly a componet on the Digital Controller is damaged | Replace Digital Controller |
| | Possibly control needs to reset | While unit is on (controller lit up) Unplug unit, wait for 1 min. then plug machine on and depress power button. |
| Digital Controller on startup goes through LED segment check (8888) then to version # and then loops back to to the above reboot. | The relay driver on the digital control may be blown. | Replace Digital Controller. |
| Digital display shows PROB. No heat on Upper Platen or Lower Platen. | Sensor lost it's continuity as shown on a muti-meter. | Disconnect prob that is open (no continuity as shown on a multi-meter. Must replace Sensor (RTD). Do not cut and splice new sensor. Install new 2000 ohm RTD sensor to under side of Heat Platen and reconnect to Controller. |
| When depressing the tactile button on Digital Controller, nothing happens. | The tactile buttons under the overlay may be not close enough to activate. Same goes if the buttons are already pressed by overlay without depressing button. | Carefully (no too much at one time to avoid fracturing the traces on the Controller) tighten the nuts on the back of the Controller until button activate. Same goes in reverse if buttons are held down by the overlay. |
| Digital display shows Relay and Particular zone is over heating or outer zone). | The Relay on the switched side is not opening to regulate temperature. | Replace the Relay. |
| Beeper not functioning or intermitten beeper sound. | Beeper on Digital Control board failed. | Replace Digital Controller board |
| If setpoint is reached but slighty off in temperature. | Offset may need to be calibrated and adjusted. | Must call (800) 624-6717 for confidential instructions. |

DOUGHPRO DP2000 Trouble Shooting Guide

| Symptom | Probable Cause | Action to be Taken |
|--|--|---|
| Heater Platen overheating | If the Relay (depending the year of the model) on the coil side are receiving 12vdc indicates the Controller is functioning properly. On the switching side of the relay, is there 120 vac going to the heater in question . If there is no voltage on the to the switching side of the relay to the heaters, the Relay is not working properly. It has been seen on remote cases, the Sensor (2M ohm) can give a false reading as well. | Replace Relay If the Controller's heat-on LED is not lit indicating the controller is working properly. If this is not the issue, replace sensor. |
| Dough not having same thickness across the press dough. | To adjust upper platen for level press | Underneath the arm resting on the Upper Platen Shroud you will find 4, stacked hex bolts sitting over the upper platen attach to the arm. The top bolts are called locking bolts. The 4 larger Hex Bolts below are Adjustment Bolts. Break free the 4 Locking blts. With a open end wrench adjust the A. bolts (1/8 turn at a time where needed and test with dough. After satisfied, tighten the Locking bolts making sure not to move the larger Adustment Bolts. |

EXPLOSION VIEW DP2010PIPSE

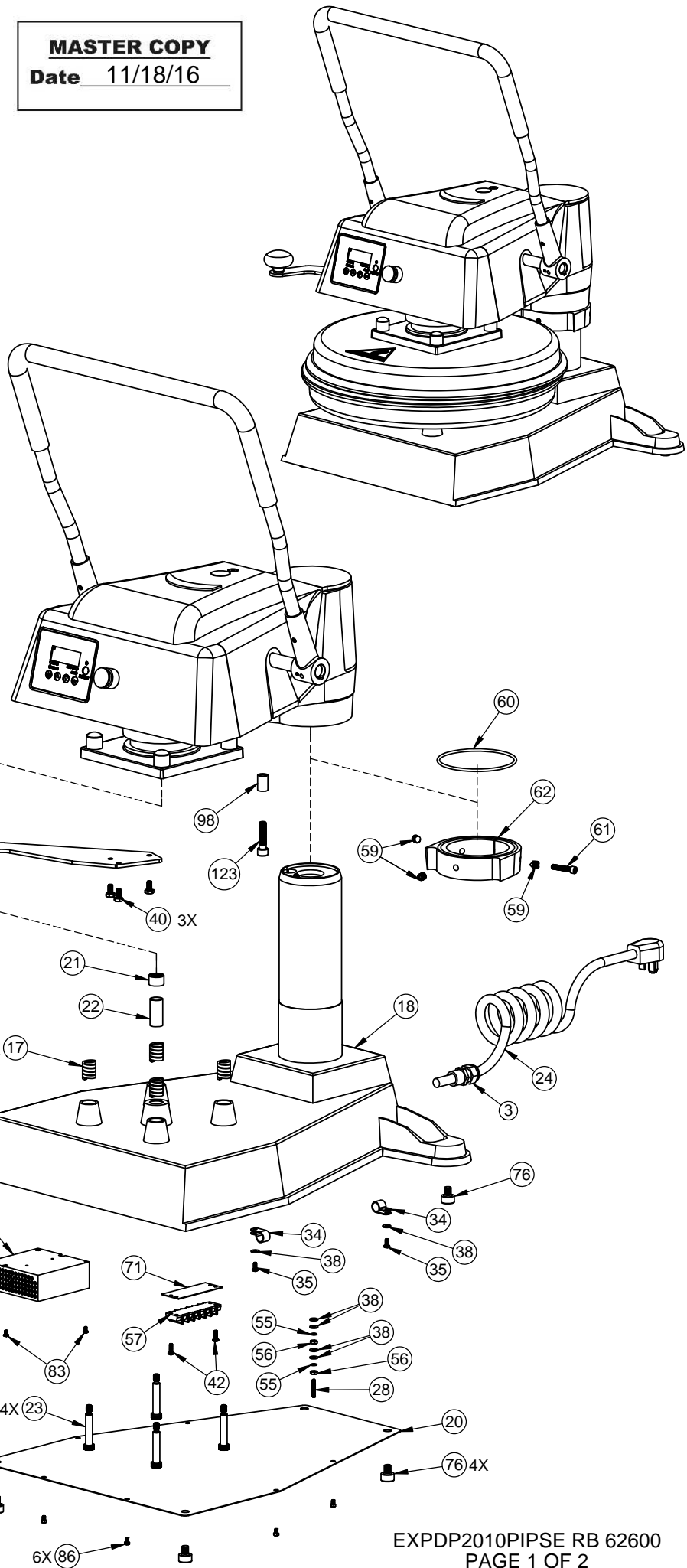
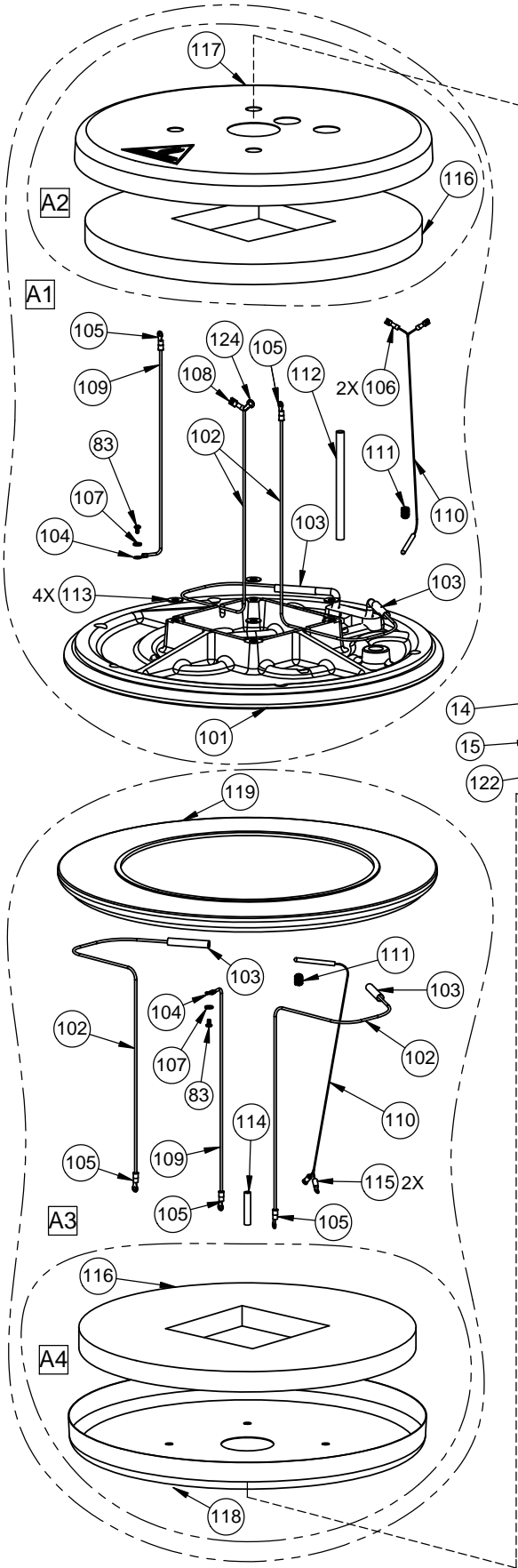

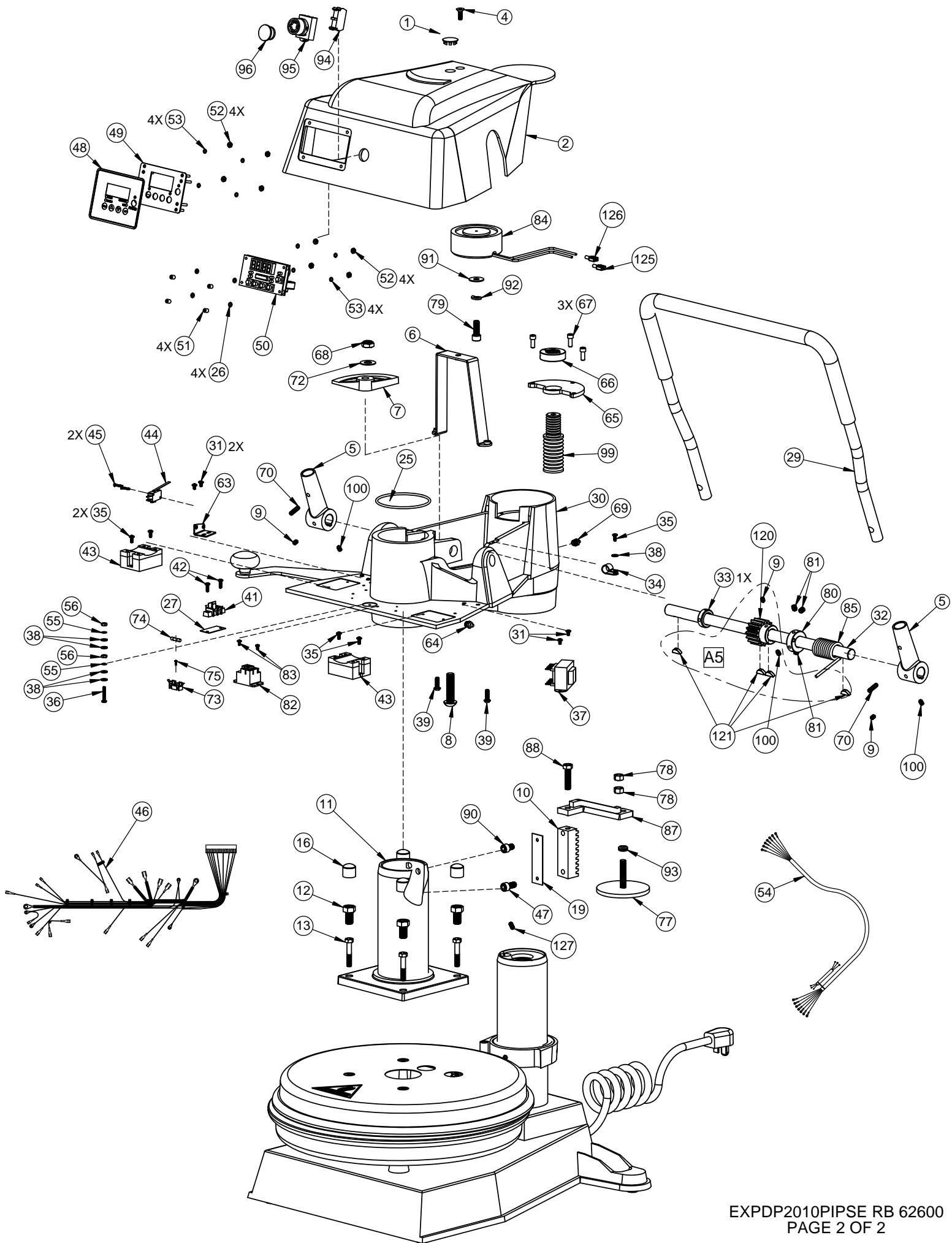

PROLUXE PARTS LIST FOR DP2010PIPSE

| ITEM # | DESCRIPTION | DP2010PIPSE | QTY. |
|--------|---|---------------|------|
| | | 208 ~ AC | |
| 1 | PLUG, METAL PUSH-IN NICKEL PLATED | 110200013 | 1 |
| 2 | HOUSING, INSTRUMENT DP2010 | 1101781542205 | 1 |
| 3 | CABLE STRAIN RELIEF | 3231 | 1 |
| 4 | SCREW, SOCKET FLAT HEAD, 1/4-20 X 3/4 | SF142034 | 1 |
| 5 | HANDLE SOCKET | 11016650 | 2 |
| 6 | BRACKET, HOUSING ASSEMBLY | 110144130 | 1 |
| 7 | CAM RAMP ASSEMBLY | 1109312 | 1 |
| 8 | SCREW, BUTTON SOCKET HEAD 1/2-20 X 2 | SB12202 | 1 |
| 9 | SCREW, SET 1/4-20X3/8" CONE POINT | SST142038CP | 3 |
| 10 | FLAT TOP, GEAR RACK | 1109383 | 1 |
| 11 | PISTON ASSEMBLY | 11018974 | 1 |
| 12 | BOLT, LEVEL ADJUSTMENT | 1109367 | 4 |
| 13 | BOLT, HEX 5/16-18 X 1 3/4 | BH51618134G5 | 4 |
| 14 | KNOB, SWING AWAY | 110017 | 1 |
| 15 | HANDLE SWING | 11023004507 | 1 |
| 16 | CAP VINYL (ADJUSTMENT SCREWS) | SC0687 | 4 |
| 17 | SPRING DIE YELLOW | 11023006 | 4 |
| 18 | BASE ASSEMBLY WITH POST | 1106191105 | 1 |
| 19 | SHIM, GEAR RACK | 110144120 | 1 |
| 20 | COVER PLATE, BASE | 11010954 | 1 |
| 21 | BUSHING, INSULATING 1/2 | 110966022 | 1 |
| 22 | WIRE SUPPORT TUBE | 110200020 | 1 |
| 23 | SHOULDER BOLT 3/8 DIA X 1-3/4 LENGTH X 5/16-18 THREAD | 11020003 | 4 |
| 24 | POWER CORD | 110573175 | 1 |
| 25 | ORING #2-238 N-70, PISTON | 238N70 | 1 |
| 26 | WASHER, STEEL | 311150019 | 4 |
| 27 | MARKER STRIP #2 | MS6992 | 1 |
| 28 | SCREW, SET 8-32 X 1 | SST8321 | 1 |
| 29 | HANDLE, PRESSURE | 1109390 | 1 |
| 30 | ARM | 1109842105 | 1 |
| 31 | SCREW, PHILLIP PAN HEAD 8-32 X 1/4 | SP83214 | 4 |
| 32 | GEAR BAR | 1109361 | 1 |
| 33 | COLLAR, GEAR BAR | 11013183 | 1 |
| 34 | CLAMP, CABLE 1/2 | CC12 | 3 |
| 35 | SCREW, PHILLIPS PAN HEAD 8-32 X 3/8 | SP83238 | 7 |
| 36 | SCREW, PAN HEAD 8-32 X 1 | SP8321 | 1 |
| 37 | TRANSFORMER | 11096975 | 1 |
| 38 | WASHER, SAE #8 | WSAE8 | 11 |
| 39 | SCREW, BUTTON HEAD 1/4-20 X 3/4 | SB142034 | 2 |
| 40 | HEX BOLT STAINLESS STEEL, 1/4-20 X 1/2 | BH142012S | 3 |
| 41 | TERMINAL BLOCK | 11098414 | 1 |
| 42 | SCREW, PHILLIPS PAN HEAD 8-32 X 1/2 | SP83212 | 4 |
| 43 | SOLID STATE RELAY | MPR90217 | 2 |
| 44 | MICRO SWITCH | V15G31C25K | 1 |
| 45 | SCREW, ROUND HEAD 4-40 X 5/8 | SR44058 | 2 |
| 46 | WIRE HARNESS | 11017815450 | 1 |
| 47 | SCREW, SOCKET HEAD 3/8-16 X 3/4 | SSH381634 | 1 |

PROLUXE PARTS LIST FOR DP2010PIPSE

| ITEM # | DESCRIPTION | DP2010PIPSE | QTY. |
|--------|--|---------------|------|
| | | 208 ~ AC | |
| 48 | OVERLAY, DIGITAL CONTROL PANEL | ODP2010PIPS | 1 |
| 49 | CONTROL, FACIA PLATE ASSEMBLY | 11086027 | 1 |
| 50 | DIGITAL CONTROL | 110178154052 | 1 |
| 51 | SPACER, NYLON 1/4 | 110969111 | 4 |
| 52 | NUT, HEX 6-32 | NH632 | 8 |
| 53 | WASHER, #6 INTERNAL TOOTH LOCK | WLIT6 | 8 |
| 54 | POWER DISTRIBUTION CABLE | 11017815467 | 1 |
| 55 | WASHER, #8 INTERNAL TOOTH LOCK | WLIT8 | 4 |
| 56 | NUT, HEX 8-32 | NH832 | 4 |
| 57 | TERMINAL BLOCK #6 | 6016 | 1 |
| 59 | SCREW, SET CONE POINT 3/8-16 X 1/2 | SST381612CP | 3 |
| 60 | ORING, POST/COLLAR | MPSS062 | 1 |
| 61 | SOCKET CAP SCREW, 1/4-20 X 1-1/4 | SSH1420114 | 1 |
| 62 | COLLAR POST ARM | 1104132305 | 1 |
| 63 | MICROSWITCH BRACKET | 1101021214 | 1 |
| 64 | FITTING, ZERK 1/4-28 | B792 | 1 |
| 65 | THRUST PLATE | 110230058 | 1 |
| 66 | CLAMP-ON SHAFT COLLAR | 110230031 | 1 |
| 67 | SCREW, SOCKET HEAD CAP, 1/4-20 x 3/4 | SSH142034 | 3 |
| 68 | NUT, LOCK NUT 1/2-20 | NHSL1220 | 1 |
| 69 | FITTING, ZERK 1/8 | B610 | 1 |
| 70 | SET SCREW SOCKET 1/4-20 X 7/8 | SST142078 | 2 |
| 71 | MARKER STRIP #6 | MS6016 | 1 |
| 73 | FUSE HOLDER 1 AMP | MPPF708 | 1 |
| 74 | FUSE BUSS 1 AMP | MPPF701R | 1 |
| 75 | SCREW PHILLIPS PAN 2-56 x 1/4 | SP25614 | 1 |
| 76 | FEET, RUBBER | RF209 | 5 |
| 77 | PLATE, MAGNET MATING | 1101763785501 | 1 |
| 78 | NUT, HEX SELF LOCKING 3/8-16 | NHSL3816 | 2 |
| 79 | SCREW, SOCKET HEAD 3/8-16 X 1 | SSH38161 | 1 |
| 80 | ADJUSTING COLLAR SPRING, HANDLE | 110115528 | 1 |
| 81 | SET SCREW KNURLED CUP POINT 5/16-18 x 3/8 | SST5161838KN | 3 |
| 82 | RELAY | 110942520 | 1 |
| 83 | SCREW, PAN HEAD 6-32 X 1/4 | SP63214 | 6 |
| 84 | ELECTROMAGNET, 12V 36W 600lbs. | 11017815413 | 1 |
| 85 | SPRING TORSION, COUNTERBALANCE | 110104454 | 1 |
| 86 | BOLT HEX SLOTTED 8-32 X 1/4 | BH83214 | 6 |
| 87 | BRACKET, MAGNET SUPPORT ASSEMBLY | 110415601 | 1 |
| 88 | SCREW, HET BOLT 3/8-24 X 1 1/2 | BH3824112 | 1 |
| 89 | AC/DC CONVERTER 12V 50W | 11017815460 | 1 |
| 90 | SCREW, SOCKET HEAD 3/8-16 X 1/2 | SSH381612 | 1 |
| 91 | WASHER, CUT (USS) 5/16 | WC516 | 1 |
| 92 | WASHER, 3/8" SPLIT LOCK | WL38 | 1 |
| 93 | GROMMET, INSULATION 3/8 ID, 7/8 OD, 3/16 THK | 110969116 | 1 |
| 94 | CONTACT N/O SCREW TYPE, GE | 110101751 | 1 |
| 95 | SWITCH, MOM P/S OP SCREW ON GE | P9XPLOSO | 1 |
| 96 | BUTTON BLACK MUSHROOM SCREW ON GE | P9ARB3N | 1 |
| 97 | MANUAL, DP2010 | MDP2010PIPS | 1 |

PROLUXE PARTS LIST FOR DP2010PIPSE

| ITEM # | DESCRIPTION | DP2010PIPSE | QTY. |
|-----------|--|------------------------|----------|
| | | 208 ~ AC | |
| 98 | BUSHING, ALIGNMENT | 110415602 | 1 |
| 99 | ADJUSTABLE SCREW | 110230042 | 1 |
| 100 | SET SCREW KNURLED CUP POINT 1/4-20 x 3/8 | SST142038KN | 3 |
| 101 | UPPER PLATEN MACHINED PIEOLOGY | 1101141474208 | 1 |
| 102 | WIRE, TGGT, 14 GA. (HEATER) | 110069 | 10.5ft. |
| 103 | TFE, SHRINK TUBING 7AWG | 110131 | 0.66ft. |
| 104 | TERMINAL, RING #6 14-16 GA HIGH TEMP | 1601HT | 2 |
| 105 | TERMINAL, RING #8 14-16 GA | 1604 | 5 |
| 106 | TERMINAL, QD 3/16 X 18-22 GA | 2280 | 2 |
| 107 | WASHER, SAE #6 | WSAE6 | 2 |
| 108 | TERMINAL, FEMALE MOLEX #BB-2141 | MPSQ100 | 1 |
| 109 | WIRE, TFE 14GA. GREEN | WTFE14G | 4.58ft. |
| 110 | RTD, SENSOR ASSEMBLY | 110949110 | 2 |
| 111 | SCREW, SET 3/8-16 X 1/2 | SST381612 | 2 |
| 112 | SLEEVING, PVC WIRE | OPVC1050 | 1.33ft. |
| 113 | WASHER, SAE 5/16 | WSAE516 | 4 |
| 114 | TFE, NON SHRINK TUBING | 110133 | .33ft. |
| 115 | TERMINAL, #6 RING x 18-22 GA | 2202 | 2 |
| 116 | FIBER GLASS INSULATION | 1101171251 | 2 |
| 117 | SHROUD, UPPER PLATEN | 1109336 | 1 |
| 118 | SHROUD, UPPER PLATEN | 110230036 | 1 |
| 119 | DP 2010 LOWER PLATEN MACHINED PIEOLOGY | DP10632208 | 1 |
| 120 | GEAR, PINION | 1109360 | 1 |
| 121 | PLAIN STEEL WOODRUFF KEY, 3/16 X 3/4 | KW931634 | 4 |
| 122 | SCREW, BUTTON HEAD 1/4-20 X 5/8 | SB142058 | 1 |
| 123 | SCREW, SOCKET HEAD 3/8-16 X 1 1/2 | SSH3816112 | 1 |
| 124 | RING TERMINAL 14-16 GA HI TEMP, #10 SCREW | 1605HT | 1 |
| 125 | TERMINAL, 1/4" 18GA 22GA FEMALE. FULLY/INS, RED | 2270FIN | 1 |
| 126 | TERMINAL, 1/4" QD FEMALE 14-16, FULLY INSUL BLUE | 1670FIN | 1 |
| 127 | SCREW, SET 1/4-20 X 1/2 | SST142012 | 1 |
| | | | |
| A1 | UPPER PLATEN WIRE ONLY | 1101141474208K | 1 |
| A2 | UPPER PLATEN COMPLETE ASSEMBLY | 1101141474208AK | 1 |
| A3 | LOWER PLATEN WIRE ONLY | DP10632208K | 1 |
| A4 | LOWER PLATEN COMPLETE ASSEMBLY | DP10632208AK | 1 |
| A5 | KITTED, PINION GEAR ASSEMBLY | 1109360K | 1 |

Warranty & Return Policy

Proluxe warrants all products manufactured by it against defects in workmanship or materials from the date of purchase for a period of (1) year on parts and **labor**. **This warranty applies to only equipment purchased and used in the United States.** Warranty period shall begin when equipment ships. Warranty travel shall only be covered for 60 miles. Limited lifetime warranty on heating elements.

ALL WARRANTY SERVICE CALLS MUST BE APPROVED BY PROLUXE. IF THIS PROCEDURE IS NOT FOLLOWED, WARRANTY SERVICE WILL NOT BE COVERED. WARRANTY SERVICE WILL BE PAID ON STRAIGHT TIME, OVERTIME WILL NOT BE COVERED.

Exclusions:

- 1. WOOD / GAS FIRED OVENS:** PROLUXE warranty applies to the main body of the oven being steel / refractory and insulation shall be free from defects in materials and workmanship for a period of four years from the date of purchase. The gas equipment shall be free from defects in materials and workmanship for a period of one (1) year from the date of purchase. Lifetime warranty against cracks on oven floor.
- 2. Air compressors are excluded from this warranty,** but PROLUXE may act as a warranty expeditor in certain instances regarding these compressors. The air compressor manufacturer provides a limited warranty and a copy of this warranty is furnished with all compressors sold by PROLUXE. For prompt handling of compressor warranty claims the instructions of the compressor manufacturer must be adhered to.
- 3. Equipment built to special order as well as accessories** cannot be canceled and are not returnable unless defective within the terms of this warranty.
- 4. In no event shall PROLUXE be liable for consequential damages arising out of the failure of any of its products if operated improperly or caused by normal wear or damage by operator abuse.**
- 5. BC2325 pedestal warranty disclaimer:** Pedestals shall only be covered under warranty if they have been cleaned using the factory approved cleaning method. cracked or damaged pedestals must be inspected by the factory before warranty is authorized.
- 6. Limited lifetime warranty on heating elements:** If replacement is needed, Proluxe will send the new part at no charge but **labor** will not be covered unless the unit is still under the 1 year manufacture warranty.

Returned Merchandise Policy:

Should it become necessary to return any of the company's products, the following instructions must be adhered to: First, contact our customer service department for approval and a return authorization number. *Please have the serial number of your item available at that time.* All merchandise must be shipped *freight prepaid* by customer or service agency. Subject to the inspection of the product by the company, a restocking charge of 20% of the Net purchased price paid to PROLUXE will be assessed. Merchandise may not be returned for credit without *prior written approval* of PROLUXE. Collect shipments *will not* be accepted. No returns after 60 days of original shipment date on machines. Purchased parts may not be returned after 30 days.

If upon inspection by PROLUXE or its authorized agent it is determined the equipment has not been used in an appropriate manner, has been modified, or has not been properly maintained, or has been subject to misuse, misapplication, neglect, abuse, accident, unauthorized modification, damage during transit, delivery, fire, flood, act or war, riot or act of God, then this warranty shall be deemed null and void.

Terms & Conditions:

1. Prices indicated in the PRICE LIST are suggested retail prices and are shown in U.S. DOLLARS.
2. Terms of Payment: 1% 10 days, NET 30 days.
3. **NEW ACCOUNTS:** Satisfactory credit information must be provided before open account status can be extended. Unless agreed otherwise, all shipments will be made C.O.D., CASH IN ADVANCE.
4. **PRICING:** Prices, specifications, model numbers, capacities and accessories are subject to change without notice.
5. **FREIGHT / ROUTING:** Method of shipment will be determined by PROLUXE unless otherwise advised by PURCHASER.
6. **DAMAGED CLAIMS:** All merchandise shipped at purchaser's risk. Inspection must be made by purchaser at time goods are received. If goods are damaged, the PURCHASER shall request that the agent of the transportation company make a written notation on the proper shipping documents immediately and then file a claim for damage. **GOODS DAMAGED IN SHIPMENT ARE NOT RETURNABLE.**
7. **RETURNS:** Machines may not be returned after 60 days. Purchased parts may not be returned after 30 days. A restocking fee of 20% will be assessed on non-warranty returns.
8. **TAXES:** Prices indicated herein DO NOT include State, Federal, Local or foreign taxes or duties, nor do they include fees, permits, insurance or other levies, all of which are the responsibility of the purchaser.
9. All orders are subject to acceptance by PROLUXE.
10. Possession of this price list shall not be considered an offer to sell.