

Operations Manual

Model: SL1266DG
Split Lid Grill



PROGRILL™



PROLUXE™

formerly DOUGHPRO. New Name. Same Quality. Superior Service.

proluxe.com

rev8-71713

Operation Instructions

Please read carefully before attempting to use this appliance.

- Step 1.** Carefully unpack and clean grill plates with mild soap then sponge clean with cold water.
- Step 2.** Place in location where it will be used allowing for clearances per the dimensions indicated.

WARNING! Allow 2” minimum clearance between adjacent equipment and/or wall areas.

Do not touch hot surfaces.

- Step 3.** Plug into proper 3 prong wall outlet. If other appliances are connected to the same circuit make sure the total load does not exceed maximum ampacity of the circuit. Electrical information is as follows:

120V/50/60Hz/1 phase/2200W/18.3 Amps

208V/60Hz/1 phase/2800W/13.5 Amps

220V/60Hz/1 phase/2200W/10.0 Amps

Step 4: Warm-up

Energize by turning on the power switch which will illuminate when turned on. The display flashes and shows left preset timer during warm-up. Pre-heat temperature time will be 40-50 minutes. When the set point is reached, the display stops flashing and beeps 3 times.

Step 4: Operation

Simply place product on either side of the grill, close lid and press the desired pre-set time cycle 10 or 20 seconds. After the time cycle is finished press it again to reset the time cycle.

Cleaning Instructions

NOTE! Always turn off power and allow to cool down before attempting to clean. ***Never submerge grill in water or other liquid nor use mineral spirits or other flammable material to clean this appliance.***

!Never use ice to cool down grill, warranty will be void!

Clean stainless steel and griddle surfaces with soap and water using a soft, clean cloth periodically as required, but at least once daily. Never use harsh abrasives. Use only non-abrasive scouring pads when required.

Clean Cycle

275°F is the factory default temp for the CLEAN cycle. To change the CLEAN cycle temp, simultaneously hold down the TEMP and CLEAN buttons for 15 seconds. The current temp setting will display on the right digital display only. Using the up or down arrows to adjust to the desired temp.

To start a clean cycle, push CLEAN button once so the CLEAN LED light is turned on. All preset LED's are turned off, and the temperature set point is changed to the clean set point of 275°F. This also initiates the cool down to clean set point condition as well the display starts flashing until the clean set point is reached.

To stop the clean cycle, simply press the CLEAN button once to deactivate the clean cycle. The CLEAN LED is turned off, the preset LED's are restored, the temperature set point is changed to the main set point. Again, the warm-up condition is initiated and the display flashes until the cook set point is reached.

SL1266 Operating Instructions:

1. Press desired time to start the time cycle. After the cycle is finished, press it again to reset the time cycle

HOW TO FIND TEMPERATURE

1. To find the temperature of the UPPER PLATENS:
Press the TEMPERATURE button and the ARROW UP button at the same time.
2. To find the temperature of the LOWER PLATENS:
Press the TEMPERATURE button and the ARROW DOWN button at the same time

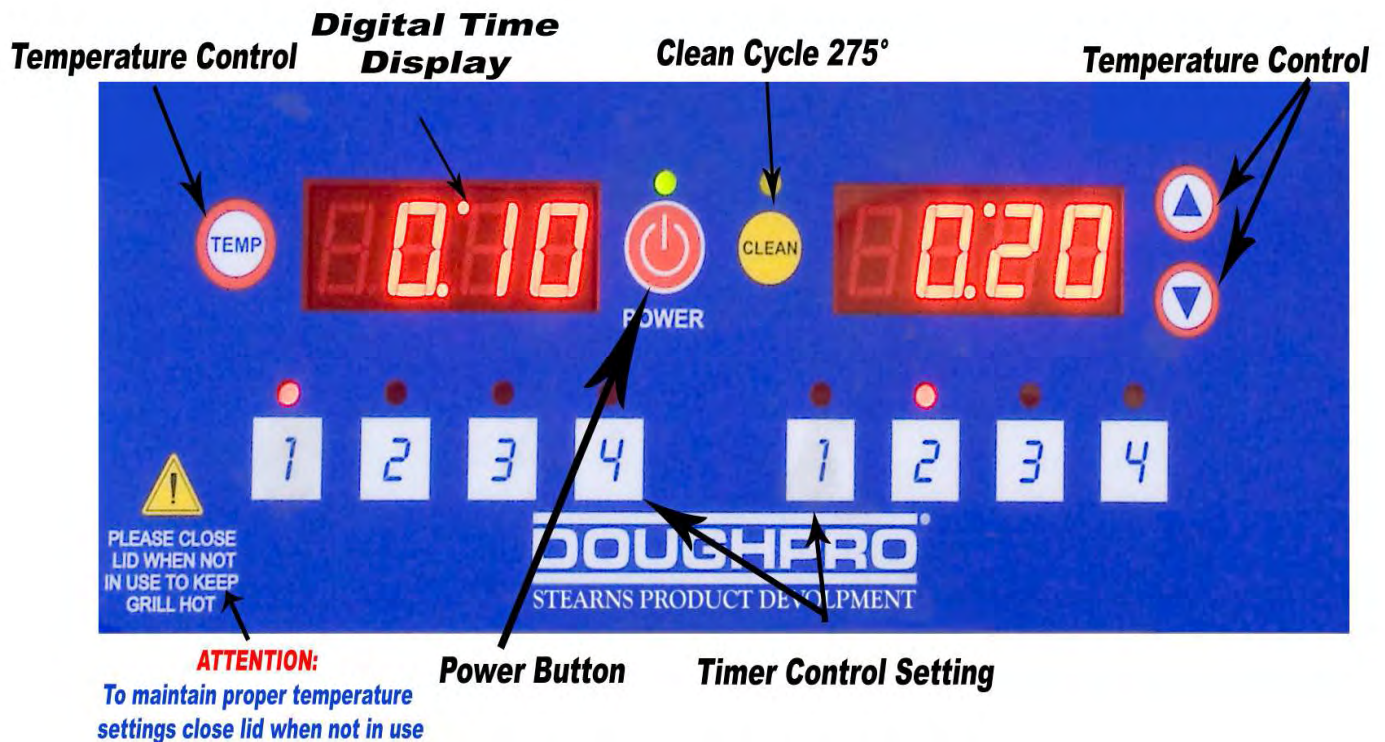

Instruction's for Adjusting the Temperature

PRESS and hold the **TEMP** and **ARROW** up buttons **simultaneously** for **15 seconds**.

The current temperature setting will display on the right digital display only.

Using the **ARROW** buttons, you may now adjust the temperature to your desired setting.

Once you have set your desired temperature simply push the **TEMP** button. The digital displays will now read the preset times.



Instruction's for Adjusting the Set-Time

Press the **TEMP** button **first** and then the **desired timer button** and **continue to hold both** for **5 seconds**.

The digital displays will now read their preset times as shown here. Each side is capable of having up to 4 different settings, making a total of 8 set-times.

Now using the **ARROW** buttons you can set your desired time.



Once you have set the desired time simply press the **TEMP** button, the unit will display the new set-time.

***IMPORTANT NOTE:** When adjusting the time settings, The **RIGHT SIDE** time buttons control the left side, so the same time you set on the right will automatically be set to the left side accordingly. If you desire an additional set of times you can adjust the left side **AFTER** you have adjusted the right side without effecting the right side settings.

DOUGHPRO
SL1266 Split Lid Grill Trouble Shooting Guide

Symptom	Probable Cause	Action to be Taken	Parts List Ref. #
Power Button on Control face is depressed but doesn't turn on.	Power Cord is not plugged in.	Plug power cord into wall 's receptacle and depress power button on controller	—
	Circuit Breaker is tripped off in the site's breaker box	Reset circuit breaker that the Grill is plugged into. Depress Power Button to turn on.	—
	Transformer has taken a electrical surge and is damaged	Replace Transformer	18
	Check voltage on the secondary side of the Transformer. If you read 12VDC then you are receiving voltage to the Controller.	Replace Controller. Controller should be on once the power button is depressed.	A8
	Possibly blown Fuse	Check fuse and repace if necessary	# 98
Digital Controller's LED's are scrambled or randomly irratic	Possibly a componet on the Digital Controller is damaged	Replace the Digital Controller.	# A8
	Possibly control needs to reset	While unit is on (controller lit up) Unplug unit, wait for 1 min. then plug machine on and depress power button.	—
Digital Controller is constantly Beeping No heat on either on left right Upper, or Lower Platen. Depress Temp. While depressing Temp., depress either up or down arrow to locate error message,"PROB" (zone 1, Lower Platen, zone 2 Left Upper Platen, zone 3, right Upper Platen.) . If occurred when depressing the up arrow indicates either the left or right Upper Platen has the open sensor or probe. same goes for the down arrow indicating Lower Platen.	Sensor in one of two zones lost it's continuity. Depress Temp. While depressing Temp., depress either up or down arrow to locate error message,"PROB" (zone 1, Lower Platen, zone 2 Left Upper Platen, zone 3, right Upper Platen.) . If occurred when depressing the up arrow indicates either the left or right Upper Platen has the open sensor or probe. same goes for the down arrow indicating Lower Platen	Disconnect prob and check for continuity (by using Ohm Meter) and replace. Do not cut and splice new sensor. Install new 2000 ohm RTD sensor to under side of Heat Platen and reconnect to Controller. Upper left and right sensor for replacement on upper platens, Lower Platen sensor for replacement for Lower Platen.	# 22 # 46
Digital Controller is beeper chirping and is over heating.	The Mechanical Relay on the switched side is not opening to regulate temperture. Same as above, hold Temp button then depress either the down or up arrow (zone 1, Lower Platen, zone 2 Left Upper Platen, zone 3, right Upper Platen.) which ever zone is the problem, you will see RLY indicating the damage (in closed position) .	Replace the Mechanical Relay.	#15
One of the three Heater Platens not close to set point.	The offset function in the Controller's setting needs to be adjusted to achieve proper shade of toast.	Call Doughpro (800) 624-6717 for instructions. This information must not to be given to operators of the SL1577. They may get confused and cause further temperature discrepancies.	—
Beeper not functioning	Beeper has failing.	Replace Controller board	# A8

DOUGHPRO
SL1266 Split Lid Grill Trouble Shooting Guide

Symptom	Probable Cause	Action to be Taken	Parts List Ref. #
Either Heater Platen is not Heating but the Digital Controller is on and appears to be functioning.	If the Mechanical Relay (s) on the coil side are receiving 12vdc indicates the Controller is functioning properly. On the switching side of the relay, is the rated voltage for the Model(120,208, or 220~AC) going to the heater in question? If there is no voltage on the to the switching side of the relay to the heaters, the Relay is not working properly	Replace Mechanical Relay.	# 15
Heater Platen overheating	The mechanical Relay may be stuck in the closed position (zone 1, Lower Platen #1 labeled on this relay, zone 2, left upper and zone 3, right upper).	Replace Mechanical Relay.	# 15
	If you are receiving 12vdc on the coil of the relay, the Controller is properly functioning thus maybe you have a break in the wire to the heater (s) or the Heater Platen lost it's continuity	One of the Heater's embedded into to the Heated Aluminum Platen may have lost Continuity. With use of a Ohm Meter a condinuity check must check at the cold pins of the heater (where the heater wire is brazed at the cold pin. This will eliminate any other failue before the the heater element validating the loss off condinuity at the source (Heater Element). If so, either the Upper left (zone 2), right (zone 2) or Lower	#15
Either Upper Heater not coming down parallel to the Lower Heater Platen.	Parallel Lever not attached either in the rear out on the Upper Heater Platen. Check to see if Parallel leveler is connected on both sides. The retaining clip attached to pin may have come off.	Reconnect the pin and the retaining E-Clip.	# 25
Upper Platen falling down or lost It's retension .	Possibly the Springs (2, one for each Upper Heater Platen has lost some retension.	Remove rear panel and adjust the retaining collars on shaft by winding spring tighter. There are mutple set screws that need to be loosened in order to wind the spring tighter. Once achieving proper tension be sure to tighten all set screws so that tension isn't lost again.	—
If one heating zone is not reaching setpoint and another heater is overheating	Sensors maybe crossed	Make sure each sensor is connected to it's prospective postion on the terminal block which in turn to the Controller.	—

PROLUXE

SL1266PSA

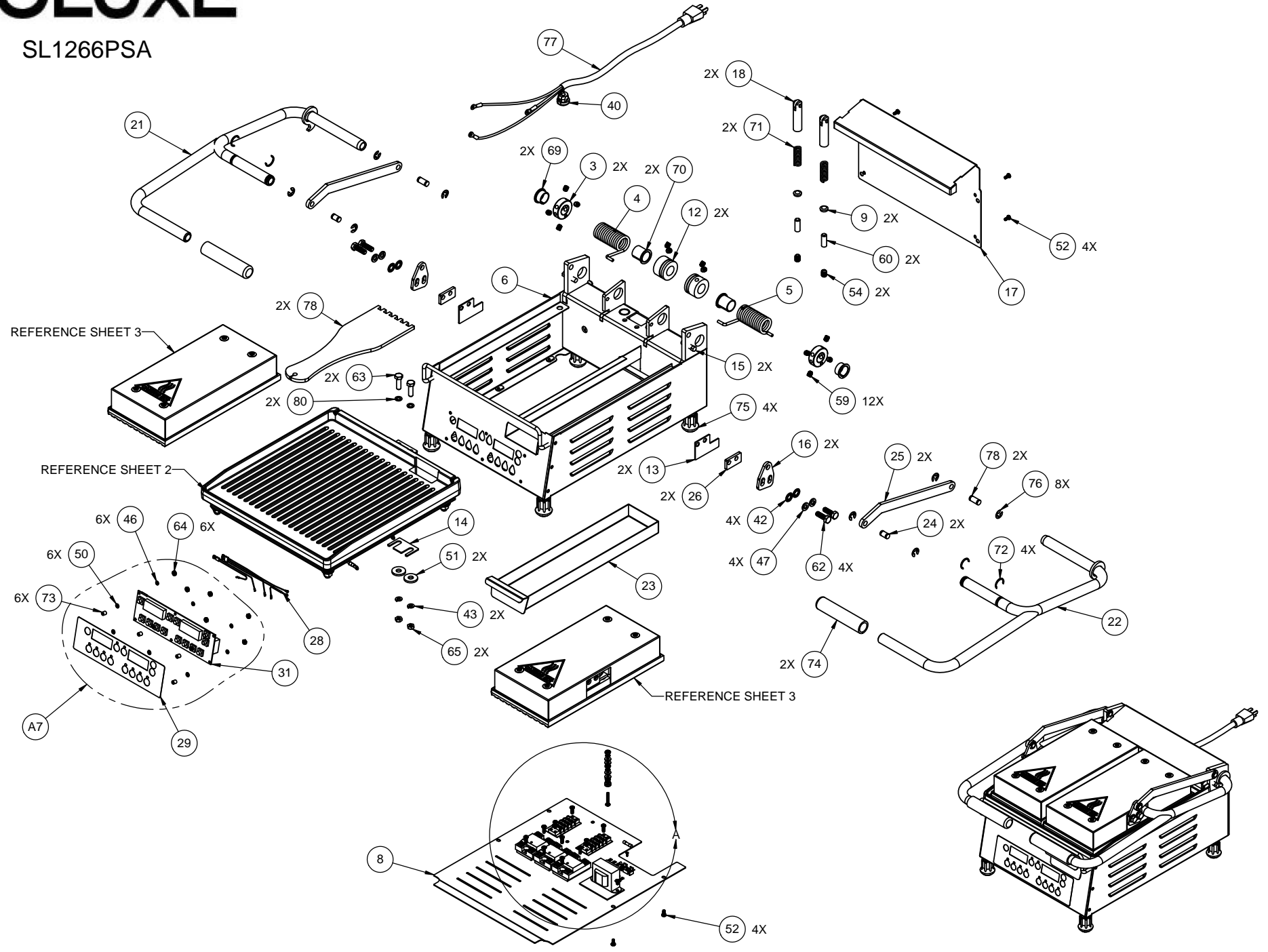

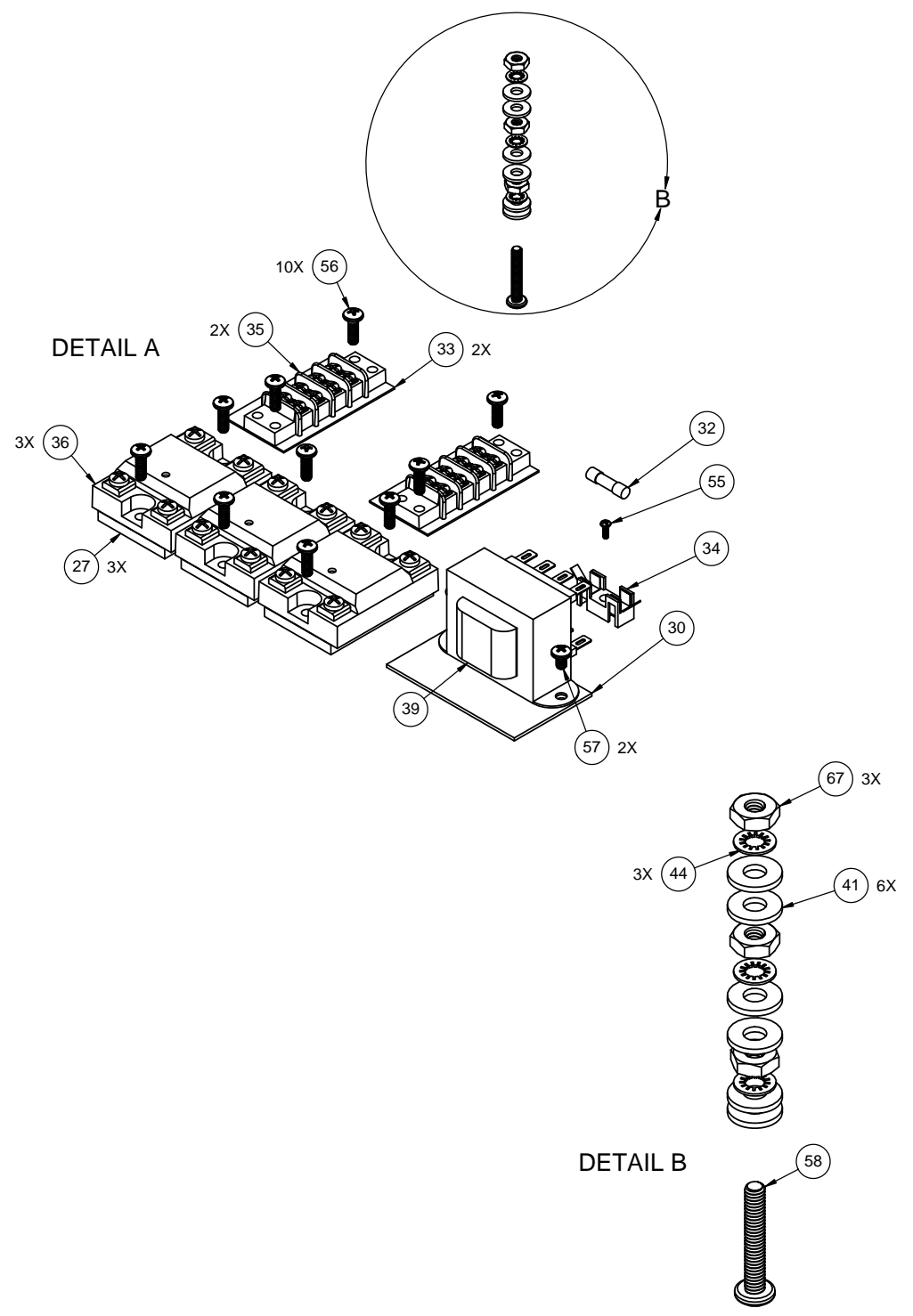
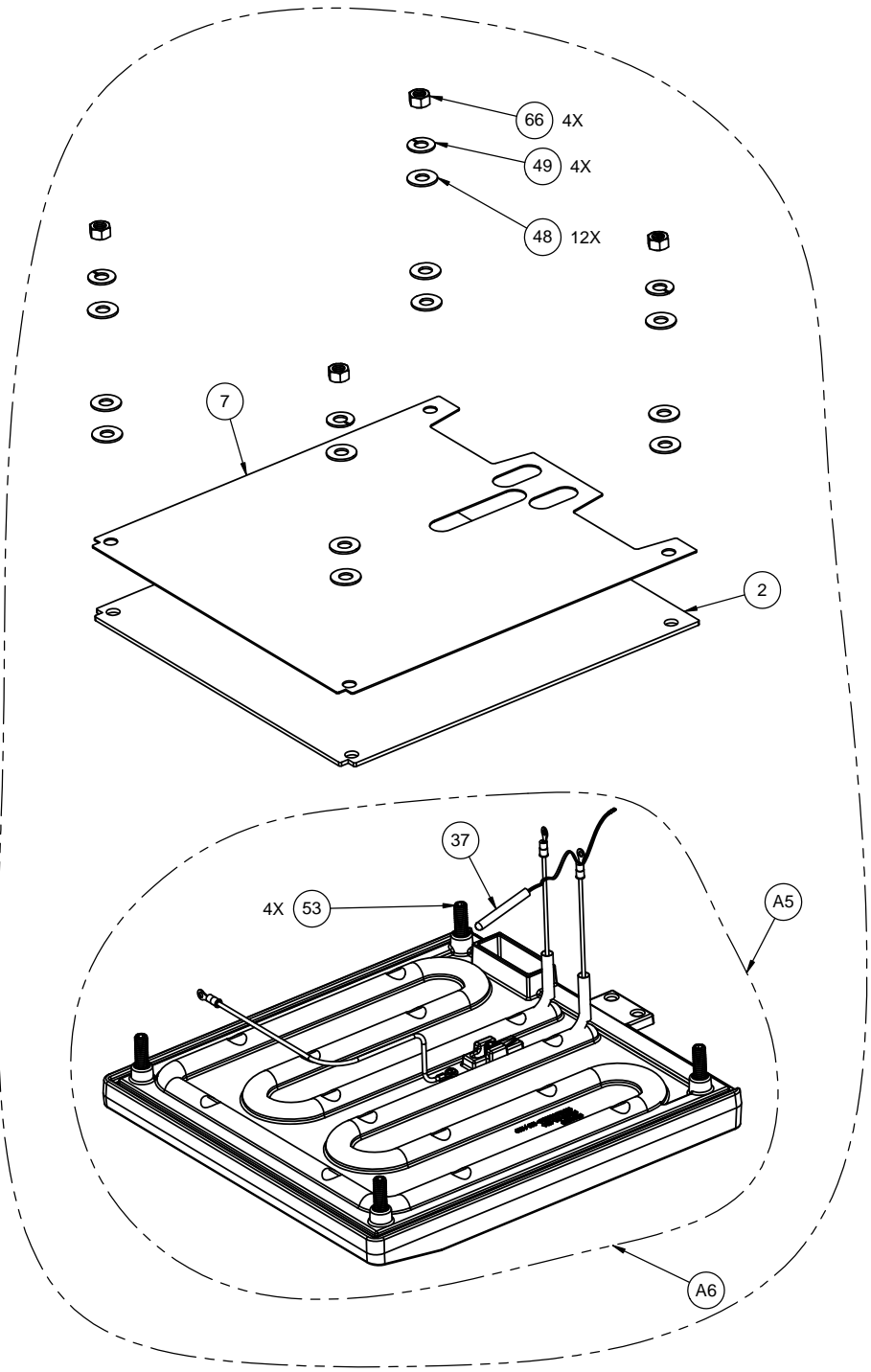

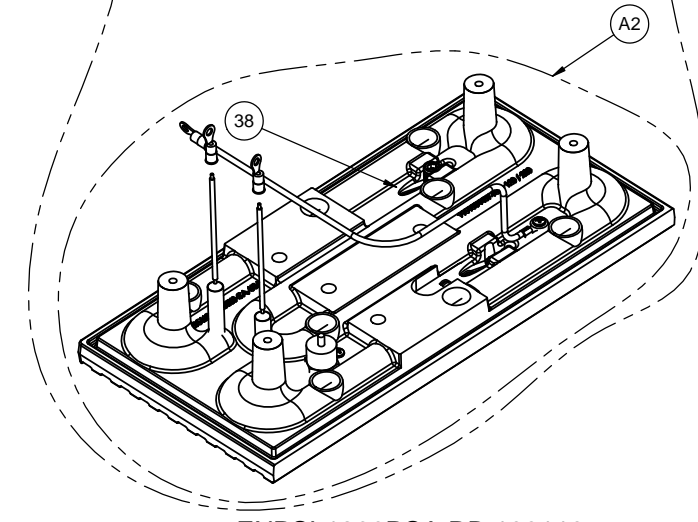
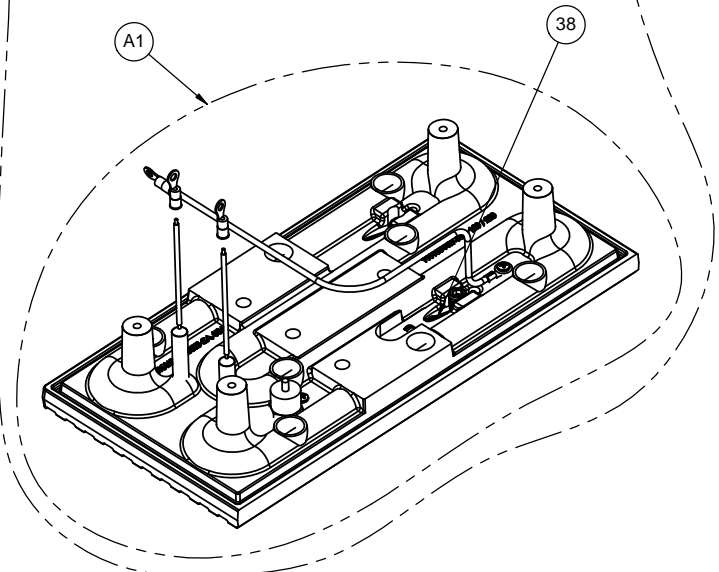
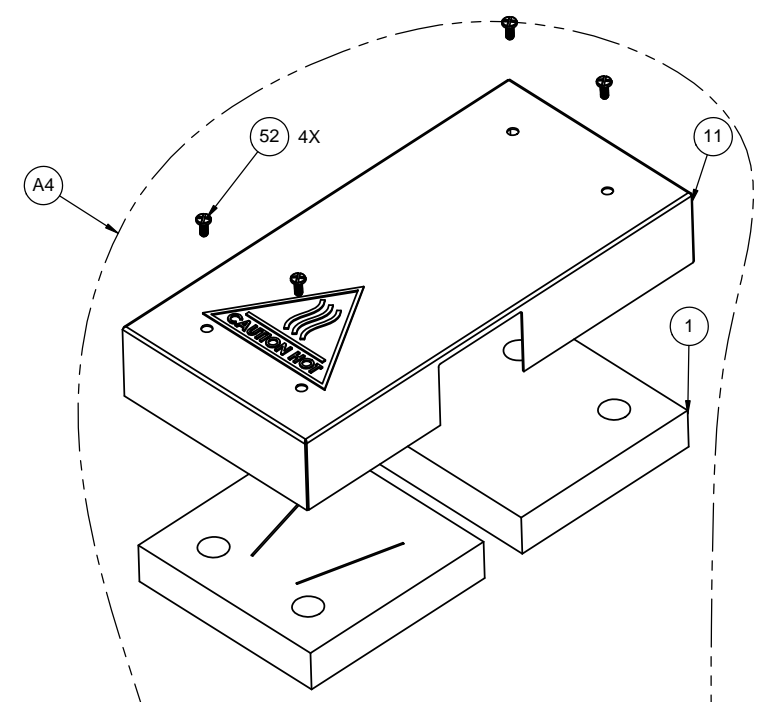
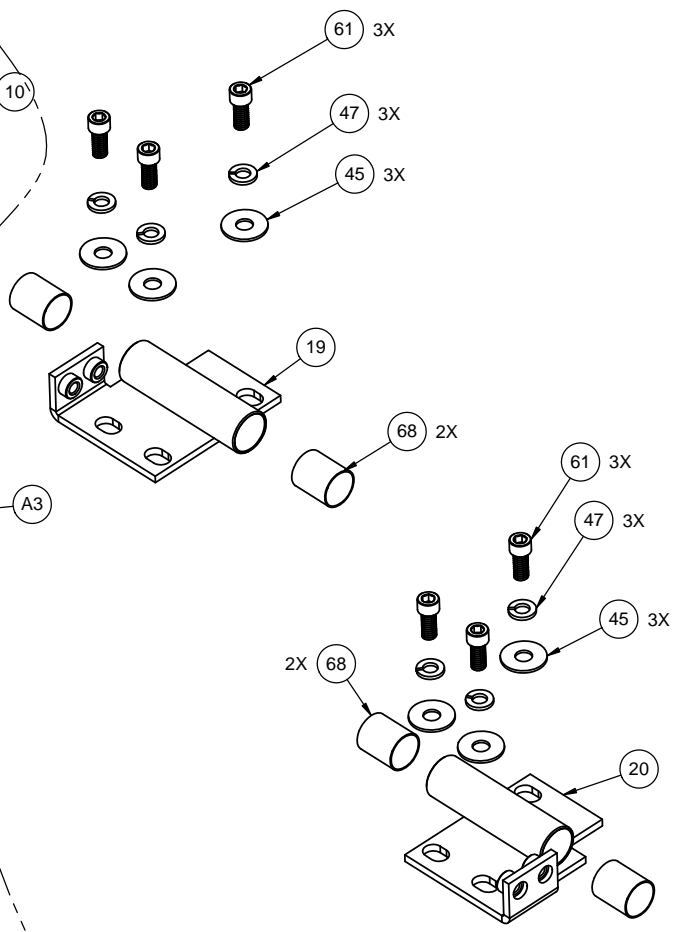
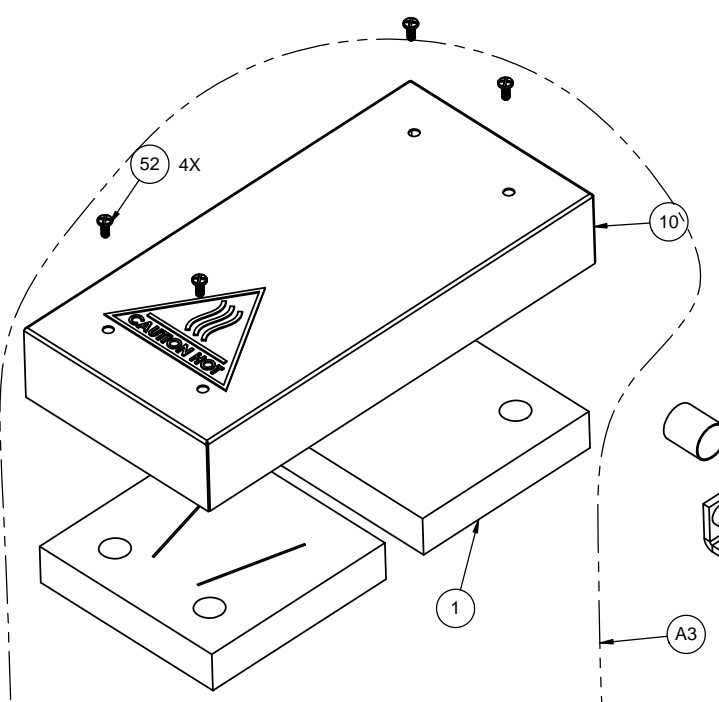

PARTS LIST FOR SL1266PSA

ITEM NO.	DESCRIPTION	SL1266PSA 120V	QTY.
1	UPPER PLATEN, INSULATION	11018344074C1	2
2	LOWER PLATEN, INSULATION	11018344019	1
3	HANDLE SPRING ADJUSTING COLLAR	110115528	2
4	SPRING TORSION LH	1101023154L	1
5	SPRING TORSION RH	1101023154R	1
6	BASE FRAME ASSEMBLY	11018344038	1
7	LOWER PLATEN INSULATION COVER	11018344018	1
8	COVER, BOTTOM ASSY	11018344022	1
9	TUBING-PAD	110115531	2
10	SHROUD, LEFT	11018344011C1	1
11	SHROUD, RIGHT	11018344010C1	1
12	CAM COLLAR	110115530	2
13	SHIM, SHROUD COVER	11018344014	2
14	SHIM, LOWER PLATEN	11018344030	1
15	STOP, HEX PIN	11018344037	2
16	LEVELING BRACKET	11018344023	2
17	COVER, REAR	11018344016	1
18	PLUNGER ASSEMBLY	110115544	2
19	CLEVIS ASSY LEFT HAND	11018344013	1
20	CLEVIS ASSY RIGHT HAND	11018344012	1
21	HANDLE LEFT ASSEMBLY	11018344027	1
22	HANDLE RIGHT ASSEMBLY	11018344026	1
23	GREASE TRAY ASSY	11018344005	1
24	PIN, PIVOT FRONT	11017088865	2
25	TOP LINK	11018344017	2
26	SPACER, LINK	11018344024	2
27	SINK, HEAT, ALUMINUM (SSR)	11057322	3
28	WIRE HARNESS	11018344050	1
29	OVERLAY SL1266	OSL1266B	1
30	TRANSFORMER INSULATION	1101159180	1
31	DIGITAL CONTROL 3 ZONE SOFTWARE REV 5.54	1101041052	1
32	FUSE BUSS 1 AMP	MPPF701R	1
33	MARKER STRIP #4 DOUBLE	MS6014	2
34	FUSE HOLDER 1 AMP	MPPF708	1
35	TERMINAL BLOCK #4, DOUBLE	6014	2
36	SOLID STATE RELAY, 25 AMPS	PL2425	3
37	2000 OHM RTD, BOTTOM SENSOR	1108881102	1
38	RTD TOP SENSOR 45.5"	1108881101	2
39	TRANSFORMER	11096975	1
40	STRAIN RELIEF	1106546468	1
41	WASHER, SAE #8	WSAE8	6
42	WASHER, LOCK INTERNAL TOOTH 5/16"	WLIT516	4
43	WASHER, LOCK 1/4	WL14	2
44	WASHER, INTERNAL TOOTH LOCK #8	WLIT8	3
45	WASHER, CUT 5/16	WC516	6
46	WASHER, INTERNAL TOOTH LOCK #6	WLIT6	6
47	WASHER, 5/16" SPLIT LOCK	WL516	10
48	WASHER, SAE 3/8"	WSAE38	12
49	WASHER, LOCK 3/8	WL38	4

PLSL1266 RB 103119 CUSTOMER

PARTS LIST FOR SL1266PSA

50	WASHER, .311 OD X .150 ID X .20 THK	311150019	6
51	WASHER, HI-TEMP COMPRESS, NON-ABESTOS	C4401	2
52	SCREW, PAN HEAD PHILLIPS 8-32X 3/8 SS	SP83238S	16
53	SCREW, SET 3/8-16 X 1-1/2	SST3816112	4
54	SCREW, SET 3/8-16 X 1/2	SST381612	5
55	SCREW, PHILLIPS PAN 2-56x1/4	SP25614	1
56	SCREW, PAN HEAD PHILLIPS 8-32 X 1/2	SP83212	10
57	SCREW, PHILLIPS PAN HEAD 8-32 X 1/4	SP83214	2
58	SCREW, PAN HEAD 8-32 X 1	SP8321	1
59	SCREW, SET 5/16-18 X 3/8 KNURLED POINT	SST5161838KN	12
60	SST SET SCREW 3 - 8 16 x 1.00	SST38161	2
61	BOLT, SOCKET HD 5/16-18X3/4"	SSH5161834	6
62	BOLT, 5/16 -18 x 1 SS HEX HEAD	BH516181S	4
63	BOLT, HEX 1/4-20X1	BH14201	2
64	NUT, HEX 6-32	NH632	6
65	NUT, HEX 1/4-20	NH1420	2
66	NUT, HEX 3/8-16	NH3816	4
67	NUT, HEX 8-32	NH832	3
68	BUSHING, TEFLON, 3/4" ID X 7/8" OD X 1" L	110115541	4
69	BUSHING, FLANGED TEFLON 3/4 ID X .875 OD X .5 L	110115563	2
70	BUSHING, FLANGED TEFLON 3/4 ID X .875 OD X 1.0 L	PG17807	2
71	SPRING, DETENT	110115555	2
72	LOW CLEARANCE CLIP	LCC3478	4
73	NYLON SPACER 1/4 X .141 X 9/32	11090109	6
74	HANDLE GRIP	110901168	2
75	FEET, RUBBER 3/4	11016546469	4
76	RETAINING RING	11017088867	8
77	POWER CORD	1101217174	1
78	PIN, LEVELER, REAR	11018344048	2
78	SCRAPER, PANINI	110115580	2
79	CLEANING INSTRUCTIONS	CISL1577	1
80	WASHER SAE 1/4	WSAE14	2
81	SL1266 MANUAL	MSL1266PSA	1
A1	UPPER PLATEN WITH WIRING LEFT SIDE	11018344074P120LK	1
A2	UPPER PLATEN WITH WIRING RIGHT SIDE	11018344074P120RK	1
A3	UPPER PLATEN LEFT SIDE ASSY	11018344074P120LAK	1
A4	UPPER PLATEN RIGHT SIDE ASSY	11018344074P120RAK	1
A5	LOWER PLATEN WITH WIRING	11018344032P120K	1
A6	LOWER PLATEN ASSY	11018344032P120AK	1
A7	CONTROLLER TEMPERATURE ASSEMBLY	11018344035K	1

VAC: 120 (220)
 AMPS: 15.8 (8.7)
 WATTS: 1900

PROLUXE
 SL1266

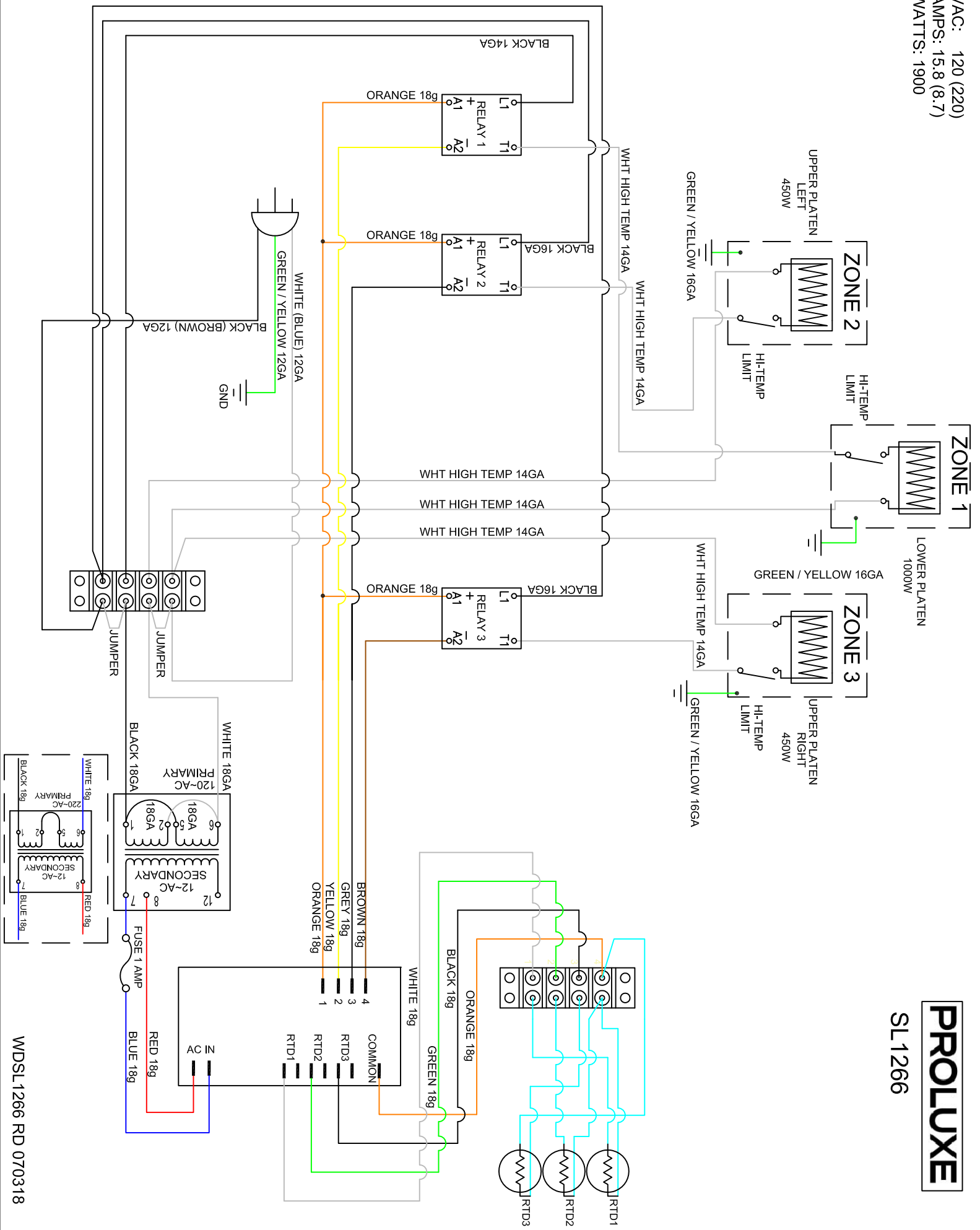

WDSL1266 RD 070318



PLEASE READ CAREFULLY BEFORE ATTEMPTING TO USE THIS APPLIANCE.

LIMITED MACHINE WARRANTY

WHAT IS COVERED

Proluxe warrants the SL1266, from manufacturing defects in workmanship and material sold within the domestic United States.

HOW LONG DOES THE COVERAGE LAST

One year warranty for parts and labor.

WHAT WE WILL DO

We will repair or replace the defective SL1266 on normal warranty one year parts and labor. The heating elements on the upper and lower platen only; will be replaced by next day air service; under the normal one year warranty. Such repair or replacement will be at the expense of Proluxe on under the normal one year warranty.

HOW TO GET SERVICE

Contact our Factory to obtain warranty service. Proluxe must issue a return authorization number, and call tag, or find the name and location of a Factory Authorized Service Center nearest you. When calling for service, please furnish the model number, serial number, and a description of the problem. Factory number 1-800-624-6717

WHAT THIS WARRANTY DOES NOT COVER

THE WARRANTIES PROVIDED BY PROLUXE DO NOT APPLY IN THE FOLLOWING INSTANCES:

- Damage due to misuse, abuse, alteration, or accident.
- Improper or unauthorized repairs.
- Submerged in water.
- Dropped.
- Damage in shipment.
- Equipment exported to foreign countries.

Warranty & Return Policy

Proluxe warrants all products manufactured by it against defects in workmanship or materials from the date of purchase for a period of (1) year on parts and **labor**. **This warranty applies to only equipment purchased and used in the United States.** Warranty period shall begin when equipment ships. Warranty travel shall only be covered for 60 miles. Limited lifetime warranty on heating elements.

ALL WARRANTY SERVICE CALLS MUST BE APPROVED BY PROLUXE. IF THIS PROCEDURE IS NOT FOLLOWED, WARRANTY SERVICE WILL NOT BE COVERED. WARRANTY SERVICE WILL BE PAID ON STRAIGHT TIME, OVERTIME WILL NOT BE COVERED.

Exclusions:

- 1. WOOD / GAS FIRED OVENS:** PROLUXE warranty applies to the main body of the oven being steel / refractory and insulation shall be free from defects in materials and workmanship for a period of four years from the date of purchase. The gas equipment shall be free from defects in materials and workmanship for a period of one (1) year from the date of purchase. Lifetime warranty against cracks on oven floor.
- 2. Air compressors are excluded from this warranty,** but PROLUXE may act as a warranty expeditor in certain instances regarding these compressors. The air compressor manufacturer provides a limited warranty and a copy of this warranty is furnished with all compressors sold by PROLUXE. For prompt handling of compressor warranty claims the instructions of the compressor manufacturer must be adhered to.
- 3. Equipment built to special order as well as accessories** cannot be canceled and are not returnable unless defective within the terms of this warranty.
- 4. In no event shall PROLUXE be liable for consequential damages arising out of the failure of any of its products if operated improperly or caused by normal wear or damage by operator abuse.**
- 5. BC2325 pedestal warranty disclaimer:** Pedestals shall only be covered under warranty if they have been cleaned using the factory approved cleaning method. cracked or damaged pedestals must be inspected by the factory before warranty is authorized.
- 6. Limited lifetime warranty on heating elements:** If replacement is needed, Proluxe will send the new part at no charge but **labor** will not be covered unless the unit is still under the 1 year manufacture warranty.

Returned Merchandise Policy:

Should it become necessary to return any of the company's products, the following instructions must be adhered to: First, contact our customer service department for approval and a return authorization number. *Please have the serial number of your item available at that time.* All merchandise must be shipped *freight prepaid* by customer or service agency. Subject to the inspection of the product by the company, a restocking charge of 20% of the Net purchased price paid to PROLUXE will be assessed. Merchandise may not be returned for credit without *prior written approval* of PROLUXE. Collect shipments *will not* be accepted. No returns after 60 days of original shipment date on machines. Purchased parts may not be returned after 30 days.

If upon inspection by PROLUXE or its authorized agent it is determined the equipment has not been used in an appropriate manner, has been modified, or has not been properly maintained, or has been subject to misuse, misapplication, neglect, abuse, accident, unauthorized modification, damage during transit, delivery, fire, flood, act or war, riot or act of God, then this warranty shall be deemed null and void.

Terms & Conditions:

1. Prices indicated in the PRICE LIST are suggested retail prices and are shown in U.S. DOLLARS.
2. Terms of Payment: 1% 10 days, NET 30 days.
3. **NEW ACCOUNTS:** Satisfactory credit information must be provided before open account status can be extended. Unless agreed otherwise, all shipments will be made C.O.D., CASH IN ADVANCE.
4. **PRICING:** Prices, specifications, model numbers, capacities and accessories are subject to change without notice.
5. **FREIGHT / ROUTING:** Method of shipment will be determined by PROLUXE unless otherwise advised by PURCHASER.
6. **DAMAGED CLAIMS:** All merchandise shipped at purchaser's risk. Inspection must be made by purchaser at time goods are received. If goods are damaged, the PURCHASER shall request that the agent of the transportation company make a written notation on the proper shipping documents immediately and then file a claim for damage. **GOODS DAMAGED IN SHIPMENT ARE NOT RETURNABLE.**
7. **RETURNS:** Machines may not be returned after 60 days. Purchased parts may not be returned after 30 days. A restocking fee of 20% will be assessed on non-warranty returns.
8. **TAXES:** Prices indicated herein DO NOT include State, Federal, Local or foreign taxes or duties, nor do they include fees, permits, insurance or other levies, all of which are the responsibility of the purchaser.
9. All orders are subject to acceptance by PROLUXE.
10. Possession of this price list shall not be considered an offer to sell.