

Operations Manual

Model: TW2540

Tortilla Warming Flat Grill



PROGRILL™



PROLUXE



formerly DOUGHPRO. New Name. Same Quality. Superior Service.

proluxe.com

CLEANING

Use only cleaners which are safe for **ALUMINUM**. **DO NOT** use caustic cleaners, ice or cold water to clean the grill. Turn grill down or OFF during idle periods to prevent carbon buildup.

1. Turn power off and unplug, allow grill to cool.
2. Remove particles by using a spatula with rounded corners.
3. Wipe down all surfaces using a warm damp cloth and mild detergent.

CARBON CLEANING

When carbon buildup occurs, use a carbon removal agent which is safe for aluminum, follow the instructions provided with the product. When this process is complete, you must re-season your grill.

INITIAL START UP

Before using the unit for the first time, wipe down the exterior and platen area with a damp cloth.

Heat for approximately 30 minutes. The warmer may emit a small amount of smoke as the cooking surface reaches its operating temperature. This is normal, as the smoke is caused by oils associated with the manufacturing process and will stop when the burn off is complete. Brush off any debris from the warming surface.

SEASONING THE TORTILLA GRILL HEATING SURFACE

FIRST TIME SEASONING

Follow your company/corporate guidelines for seasoning cooking surfaces or perform the following:

1. Bring the grill to 300°F (148°C) and leave it on while performing the next three steps.
2. Brush the cooking surfaces with a release agent. If using an aerosol agent, first apply into a cup and then brush onto cooking surface.
3. Let sit for 20 minutes.
4. Wipe the cooking surface clean, using a warm damp cloth.

Warning

DO NOT SUBMERGE IN WATER OR ALLOW WATER TO SPILL INTO THE ELECTRICAL HOUSING. AS THIS WILL VOID WARRANTY AND DAMAGE THE UNIT.

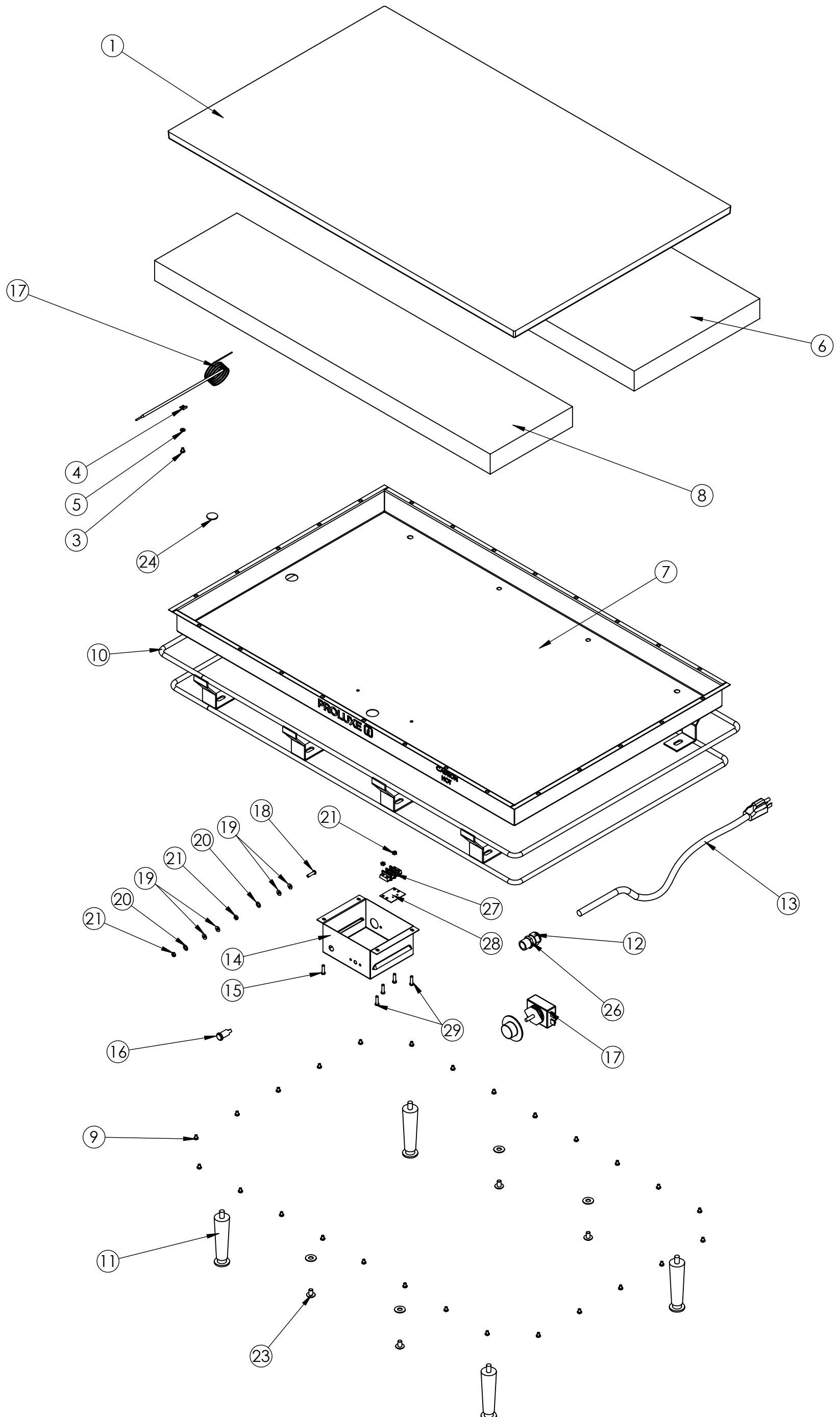

TW2540E

ITEM #	PART #	DESCRIPTION	QTY.
1	110115131	PLATEN, HEATER, 208 VOLTS, 25 x 40	1
3	SP63214	SCREW, PHIL. 6-32 x 1/4	1
4	110108881	SENSOR HOLD	1
5	WSAE6	WASHER #6	1
6	110108815	INSULATION, FIBERGLASS 15 x40	1
7	110108854	SHROUD 25 x 40	1
8	110108810	INSULATION, FIBERGLASS 10 x 40	1
9	SP102414S	SCREW, PHIL. 10-24 x 1/4 SST	26
10	110108640	BURN GUARD ASSEMBLY, TW2540E	1
11	AE601653	LEG, APPLIANCE, 4"	4
12	3231	RELIEF STRAIN	1
13	1101009176	POWER CORD	1
14	11082322	HOUSING, TW1520	1
15	SP83238S	SCREW, PHIL. 8-32 x 3/8 SST	4
16	11016938818G	LIGHT PILOT 250~AC (GREEN)	1
17	11051452	THERMOSTAT CONTROLLER ASSEMBLY 570 F	1
18	SP83234S	SCREW, PHIL. 8-32 x 3/4 SST	1
19	WSAE8	WASHER #8	4
20	WLIT8	WASHER #8 INTERNAL TOOTH LOCK	2
21	NH832	NUT, HEX 8-32	4
23	SB5161812S	SCREW, BUTTON HD 5/16-18 x 1/2	4
24	PB78	BUTTON, PLUG 7/8"	1
25	MTW2540	MANUAL TW2540	1
26	NC12	NUT, CONDUIT 1/2"	1
27	6013	TERMINAL BLOCK #3, DOUBLE	1
28	MS6013	MARKER STRIP #3, DOUBLE	1
29	SP83258S	SCREW, PAN HEAD 8-32X5/8 SST	2

VAC: 208
AMPS: 15.39
WATTS: 3200

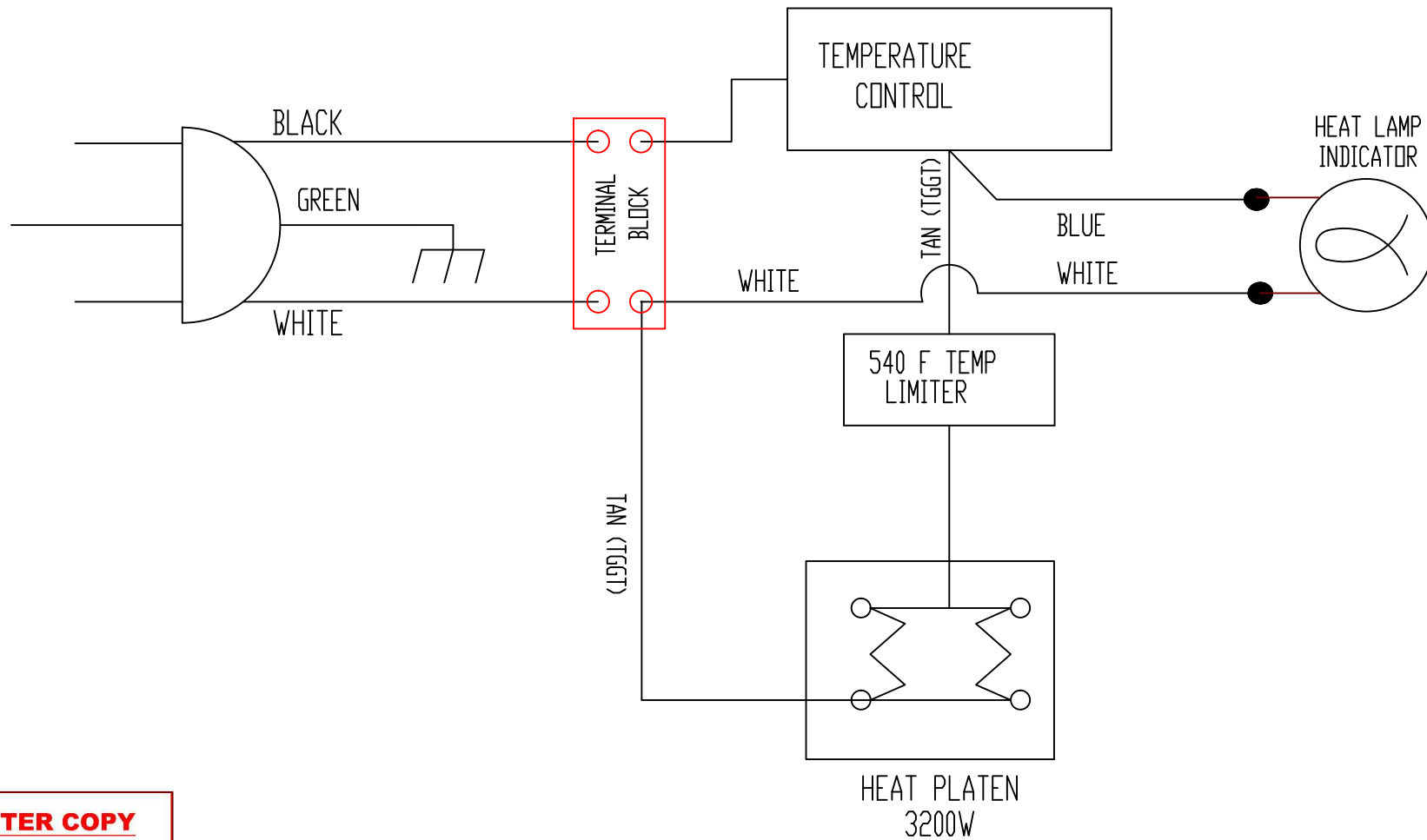

MASTER COPY
Date 12/21/12



PLEASE READ CAREFULLY BEFORE ATTEMPTING TO USE THIS APPLIANCE.

LIMITED MACHINE WARRANTY

WHAT IS COVERED

Proluxe warrants the TW Series, from manufacturing defects in workmanship and material sold within the domestic United States.

HOW LONG DOES THE COVERAGE LAST

One year warranty for parts and [labor](#).

WHAT WE WILL DO

We will repair or replace the defective TW Series on normal warranty one year parts and [labor](#). The heating elements on the upper and lower platen only; will be replaced by next day air service; under the normal one year warranty. Such repair or replacement will be at the expense of Proluxe on under the normal one year warranty.

HOW TO GET SERVICE

Contact our Factory to obtain warranty service. Proluxe must issue a return authorization number, and call tag, or find the name and location of a Factory Authorized Service Center nearest you. When calling for service, please furnish the model number, serial number, and a description of the problem.

WHAT THIS WARRANTY DOES NOT COVER

THE WARRANTIES PROVIDED BY PROLUXE DO NOT APPLY IN THE FOLLOWING INSTANCES:

- Damage due to misuse, abuse, alteration, or accident.
- Improper or unauthorized repairs.
- Submerged in water.
- Dropped.
- Damage in shipment.
- Equipment exported to foreign countries.



Warranty & Return Policy

Proluxe warrants all products manufactured by it against defects in workmanship or materials from the date of purchase for a period of (1) year on parts and labor. **This warranty applies to only equipment purchased and used in the United States.** Warranty period shall begin when equipment ships and will not exceed 90 days past the original shipment date. Warranty travel shall only be covered for 60 miles.

ALL WARRANTY SERVICE CALLS MUST BE APPROVED BY PROLUXE. IF THIS PROCEDURE IS NOT FOLLOWED, WARRANTY SERVICE WILL NOT BE COVERED. WARRANTY SERVICE WILL BE PAID ON STRAIGHT TIME, OVERTIME WILL NOT BE COVERED.

Exclusions:

- 1. WOOD / GAS FIRED OVENS:** PROLUXE warranty applies to the main body of the oven being steel / refractory and insulation shall be free from defects in materials and workmanship for a period of four years from the date of purchase. The gas equipment shall be free from defects in materials and workmanship for a period of one (1) year from the date of purchase. This warranty excludes the tandoori and home oven. Lifetime warranty against cracks on oven floor.
- 2. TANDOORI & HOME OVENS:** PROLUXE warrants the Tandoori & Home Oven including gas equipment shall be free from defects in materials and workmanship for a period of one (1) year from the date of purchase.
- 3. Air compressors are excluded from this warranty,** but PROLUXE may act as a warranty expeditor in certain instances regarding these compressors. The air compressor manufacturer provides a limited warranty and a copy of this warranty is furnished with all compressors sold by PROLUXE. For prompt handling of compressor warranty claims the instructions of the compressor manufacturer must be adhered to.
- 4. Equipment built to special order as well as accessories** are not returnable unless defective within the terms of this warranty.
- 5. In no event shall PROLUXE be liable for consequential damages arising out of the failure of any of its products if operated improperly or caused by normal wear or damage by operator abuse.**
- 6. BC2325 pedestal warranty disclaimer:** Pedestals shall only be covered under warranty if they have been cleaned using the factory approved cleaning method. cracked or damaged pedestals must be inspected by the factory before warranty is authorized.

Returned Merchandise Policy:

Should it become necessary to return any of the company's products, the following instructions must be adhered to: First, contact our customer service department for approval and a return authorization number. *Please have the serial number of your item available at that time.* All merchandise must be shipped *freight prepaid* by customer or service agency. Subject to the inspection of the product by the company, a restocking charge of 20% of the Net purchased price paid to PROLUXE will be assessed. Merchandise may not be returned for credit without *prior written approval* of PROLUXE. Collect shipments *will not* be accepted. No returns after 60 days of original shipment date on machines. Purchased parts may not be returned after 30 days.

If upon inspection by PROLUXE or its authorized agent it is determined the equipment has not been used in an appropriate manner, has been modified, or has not been properly maintained, or has been subject to misuse, misapplication, neglect, abuse, accident, unauthorized modification, damage during transit, delivery, fire, flood, act or war, riot or act of God, then this warranty shall be deemed null and void.

Terms & Conditions:

- Prices indicated in the PRICE LIST are suggested retail prices and are shown in U.S. DOLLARS.
- Terms of Payment: 1% 10 days, NET 30 days.
- NEW ACCOUNTS:** Satisfactory credit information must be provided before open account status can be extended. Unless agreed otherwise, all shipments will be made C.O.D., CASH IN ADVANCE.
- PRICING:** Prices, specifications, model numbers, capacities and accessories are subject to change without notice.
- FREIGHT / ROUTING:** Method of shipment will be determined by PROLUXE unless otherwise advised by PURCHASER.
- DAMAGED CLAIMS:** All merchandise shipped at purchaser's risk. Inspection must be made by purchaser at time goods are received. If goods are damaged, the PURCHASER shall request that the agent of the transportation company make a written notation on the proper shipping documents immediately and then file a claim for damage. **GOODS DAMAGED IN SHIPMENT ARE NOT RETURNABLE.**
- RETURNS:** Machines may not be returned after 60 days. Purchased parts may not be returned after 30 days. A restocking fee of 20% will be assessed on non-warranty returns.
- TAXES:** Prices indicated herein DO NOT include State, Federal, Local or foreign taxes or duties, nor do they include fees, permits, insurance or other levies, all of which are the responsibility of the purchaser.
- All orders are subject to acceptance by PROLUXE.
- Possession of this price list shall not be considered an offer to sell.