

---

# *5/9 THE OVEN*

---

## **ELECTRIC HALF - SIZE CONVECTION OVEN**

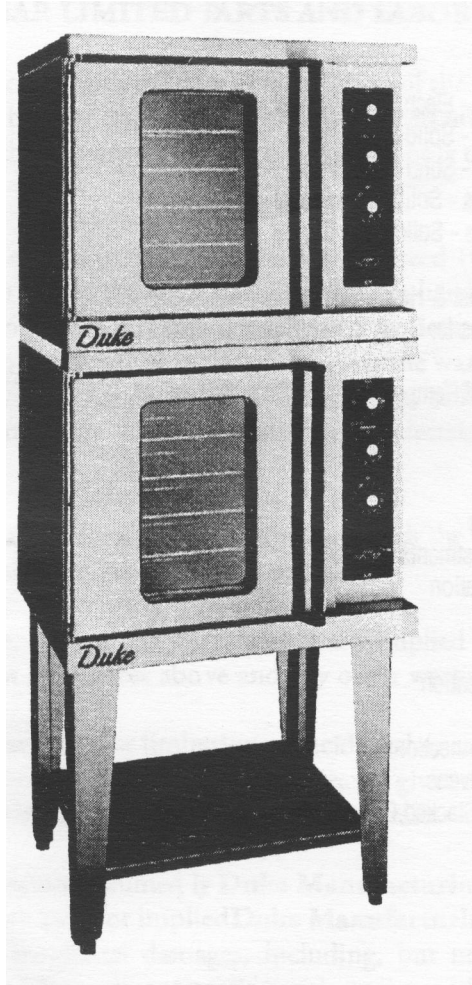

### *Installation, Operation, Parts & Maintenance Manual*



"Your Solutions Partner"

DUKE MANUFACTURING CO.  
2305 N. Broadway • St. Louis, MO 63102  
800.735.3853 • 314.231.1130 • 314.231.5074 Fax  
[www.dukemfg.com](http://www.dukemfg.com)

155131P

---

## INDEX

	<b>PAGE</b>
<b>5/9 Electric Specifications</b>	3
<b>Installation Instructions</b>	
A. Qualified Personnel	4
B. Delivery & Inspection	4
C. Location of Oven	4
D. Electrical Connections	4-5
E. Oven Assembly	5
F. Adjustments Associated with Installation	5
<b>Operating Instructions</b>	
A. Oven Controls	6-25
B. General Guidelines for Operation	26
C. Suggested Times & Temperatures	27
D. Cook & Hold – Roast & Hold	28
<b>Maintenance Instructions</b>	
A. Adjustments	29
B. Door Adjustment	29
C. Door Switch Adjustment	29
D. Thermostat Calibration	29-30
E. Cleaning the Oven	30
Repair Parts List	31
Door Assembly	32
“V” Controller Assembly	33
“X” Controller Assembly	34
“Z” Controller Assembly	35
“XX” Controller Assembly	36
“ZX” Controller Assembly	37
“ZZ” Controller Assembly	38
Contactor Identification	39
Flue Guard	40
Double Stack Ovens	40
Wiring Diagrams	42 - 51

**Please supply the ID Number and the Serial Number when  
ordering replacement parts or requesting service.**

We recommend service by Duke Authorized Service Agencies during and after the warranty period.

**FOR YOUR SAFETY:**  
Do not store gasoline or other flammable vapors or liquids in the vicinity of this or any other appliance.

**WARNING:**  
Improper installation, adjustment, alteration, service or maintenance can cause property damage, injury or death. Read the installation, operating and maintenance instructions thoroughly before installing or servicing this equipment.

**ELECTRICAL SPECIFICATIONS**

<u>Total KW</u>	<u>VOLTS</u>	<u>1 PHASE</u>	<u>3 PHASE</u>
8.0	208	41.0	24.0 amps/pl
8.0	240	36.0	21.0 amps/pl

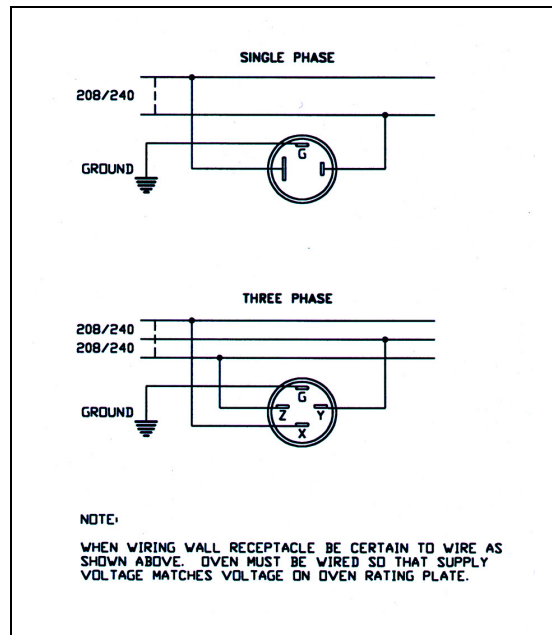
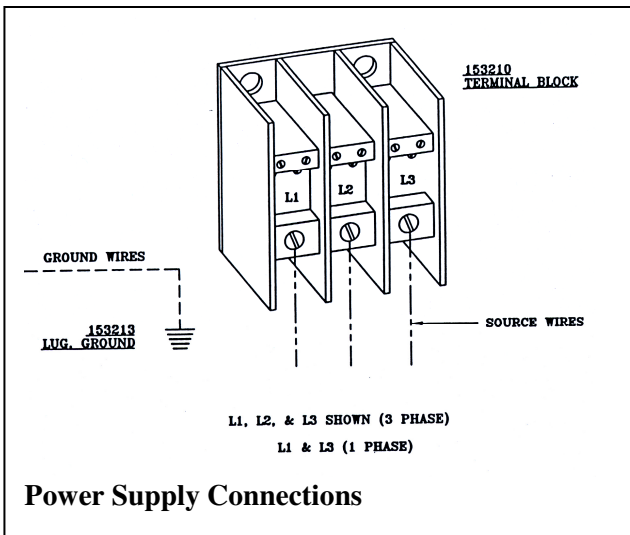

---

## INSTALLATION INSTRUCTIONS:

### A. Qualified Personnel

These installation instructions are for the use of qualified installation and service personnel only. Installation or service by other than qualified personnel may result in damage to the oven and/or injury to the operator.

Qualified installation personnel are those individuals, firms, companies or corporations which either in person or through an agent is engaged in and responsible for:

- The installation of electrical wiring from the electric meter, main control box or service outlet to the electrical appliance. Qualified installation personnel must be familiar with all precautions required and have complied with all requirements of state and local authorities having jurisdiction. See: National Electrical Code, ANSI/NFPA70.

### B. Delivery and Inspection

Duke Manufacturing Co. does everything within its power to insure you received your oven in good condition. They are strapped down on heavy wooden skids and surrounded by heavy "tri-wall" cartons to prevent shipping damage. They have all been carefully inspected before they were packaged and consigned to the carrier.

Upon delivery of your Duke oven:

- Look over the shipping container, carefully noting any exterior damage on the delivery receipt, which must also be signed by the driver/ delivery person.
- Uncrate and check for any damage, which was not evident on the outside of the shipping container. This is called concealed damage. The carrier must be notified within fifteen (15) days of the delivery of the oven and the carton, skid and all packaging materials must be retained for inspection.

Duke Manufacturing Co. cannot assume liability for loss or damage suffered in transit. The carrier assumes full responsibility for delivery in good order when the shipment was accepted. However, we are prepared to assist you in filing your claim.

### C. Location of the Oven

Proper planning and placement of the oven will give you the best results in terms of long-term user convenience and satisfactory performance. We urge you to give adequate thought in the placement of your oven prior to its arrival.

- The oven should be placed in an area that is free

from drafts and accessible for proper operation and servicing.

- The area around the oven must be kept clear of combustible materials. A minimum clearance of:

	Combustible	Non-Combustible
RIGHT SIDE	1"	0"
LEFT SIDE	1"	0"
REAR	3"	3"
FLOOR	8"	8"

Must be maintained between the oven and any combustible or non-combustible surface.

It is also important not to obstruct the natural flow of ventilation air if the oven is to operate properly. This oven should not be installed on a curb base or sealed to the wall. Either condition can restrict the flow of air to or prevent proper ventilation of the blower motor. The blower motor has a thermal protection device, which will trip, because of excessive ambient temperatures at the back of the oven. This condition should be corrected immediately to avoid damaging the oven permanently.

The flue located near the top at the rear of the oven must not be obstructed. Proper ventilation is important to avoid high temperatures at the rear of the oven. High temperatures can cause premature blower motor failure.

Before making any connections to the oven, check the rating plates to be sure the oven specifications concur with the voltage and phase to be supplied to the oven.

The rating plate is located behind the lower front panel. To access, loosen the four screws below the doors, and pull the panel outward.

The plate bearing the oven's serial number is attached to the underside of the upper ledge above the control panel.

### D. Electrical Connections

Your oven is supplied for connection to a 208, 240, 440 or 480 volt grounded circuit. The electric motor, oven lights, indicator lights and control circuits are connected internally and require no secondary power supply.

Before making any connections to these units, check the rating plate to assure that the voltage and phase

---

of the oven is compatible with the electrical supply. When installing, all ovens must be electrically grounded in accordance with local codes or in the absence of local codes, with the National Electrical Code, ANSI/NFPA 70 (in Canada – CSA Std. C22.1). Wiring diagrams are located in the control compartment area. Standard wiring schematics are also included at the back of this manual.

The proper method of connecting the power source to the terminal block is shown in the Exploded Views Section.

### **Note to Electrical Inspector:**

**Inspection of electrical connection should be accomplished by the removal of the Control Panel.**

### **E. Oven Assembly**

Before assembling and installing the oven, please check to make sure that all necessary parts are present. In addition to the oven itself, there will also be legs, feet or casters, the vent guard, (for double sections, retaining clips, vent riser) and miscellaneous hardware. Please check the interior of all oven sections for the parts needed to assemble and install your oven(s).

#### **Leg Attachment**

- Once the oven has been removed from the carton, lay it on its lift side (the side without the controls).
- Position one of the legs against the bottom of the oven, aligning the center hole on the leg plate with the center threaded hold on the bottom of the oven.
- While supporting the leg, carefully start the bolt in the center hole and finger tighten. (Avoid cross threading.)
- Align the other two leg plate holes with those in the bottom of the oven.
- Carefully start the bolts in the remaining holes and finger tighten. (Avoid cross threading.)
- Secure each of the bolts using a wrench.
- Repeat this process for all legs.
- Add the two (2) storage shelves between the four (4) legs and secure with the bolts provided.
- Raise the oven up on the legs.

Level the oven by turning the adjustable feet in or out as needed.

### **Caster Installation**

Casters are available as an option for double oven sections. They are packed inside the oven for shipment.

- Place the tip of a large screwdriver against the lip of the adjustable foot on the bottom of the leg.
- Using a hammer, drive the foot out of the leg.
- Insert the caster fully into the opening where the foot came out.
- Using a wrench, tighten the locking nut on the bottom of the caster to expand the compression sleeve until secure.
- Repeat this process for the remaining legs.

**NOTE: The casters with locking brakes are best mounted on the front side of the oven for easier access.**

**NOTE: If you plan to use casters, a fixed restraint of the proper length is recommended to eliminate strain on the connecting wire. If the oven is removed from its normal position, the restraint must then be reattached when returned.**

### **F. Adjustments Associated with Installation**

Each oven section and all its component parts have been tested thoroughly and inspected before your oven was shipped from the factory. However, it is sometimes necessary to further test or adjust the oven once it has been installed. Such adjustments are the responsibility of the Dealer or Installer. These types of adjustments are not considered defects, rather a normal and routine part of the proper installation of the equipment.

These adjustments include but are not limited to:

- Adjustments and recalibration of the thermostat
- Adjustment to the doors.
- Leveling.
- Tightening of fasteners.

**No installation should be considered complete without proper inspection and, if necessary, any adjustments by qualified service or installation personnel.**

## V” Controller

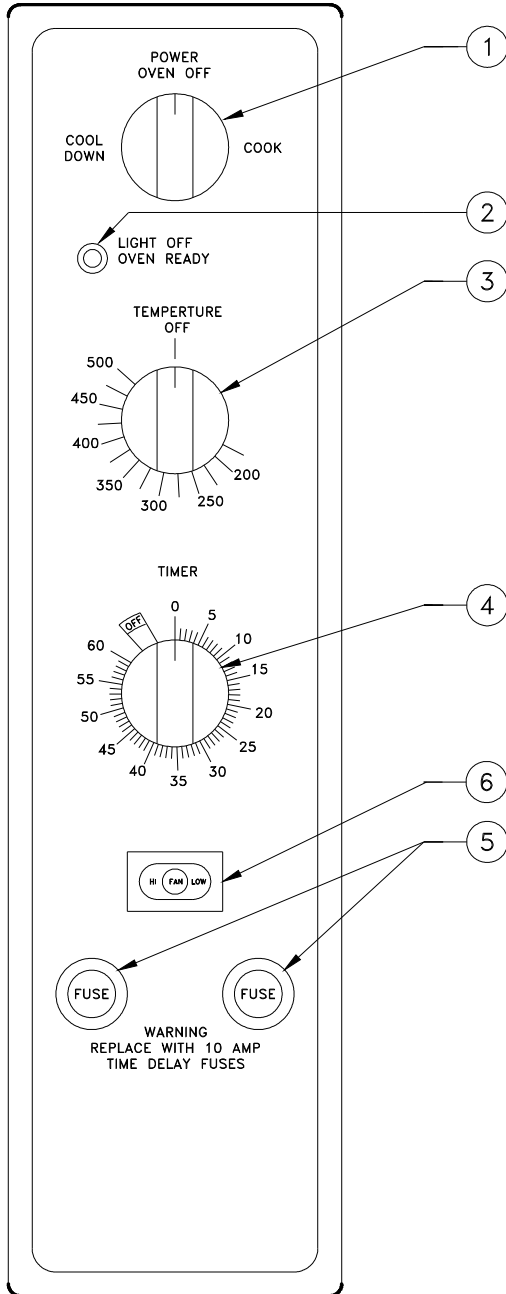

### A. Oven Controls - Electro-Mechanical

- **1. The Power Switch** - Controls power to ON or Cool Down Function.
- **2. The Indicator Light** - When lit indicates burners are operating. When the light goes out, the oven has reached its cooking temperature.
- **3. The Cooking Thermostat** - Controls the oven temperature.
- **4. The Cooking Timer** - Sounds an electric buzzer on expiration of operator set time as a reminder to remove product at end of cooking cycle.
- **5. The Fuse Holders** - Contain circuit protecting fuses.
- **6. The Fan Speed Switch (Optional)** - Sets fan speed to high or low.

---

## Operating Instructions - “V” Controller

### Timer Resolution

The Timer displays time from 0 to 60 minutes, in one-minute increments.

### Temperature Scale

The Temperature Control displays the temperature in °F. The temperature range is from 150°F - 500°F, in 25°F increments.

### Cool Down

This feature enables the oven to be cooled rapidly by allowing the fan to operate with the heating elements turned off. To activate, turn the Power Switch to the COOL position and open the oven door. When the door is opened enough to disengage the door switch, the fan will turn on. Closing the door will turn the fan off.

### Fan Speed Switch

The fan speed can be set to high or low speed by placing the FAN HI/LOW button to the desired setting.

### Cooking

A cooking cycle can be initiated as follows:

- Turn the Power Switch to COOK position.
- Set the Cooking Temperature by turning the TEMPERATURE dial to the desired temperature. The OVEN READY indicator light will turn on.
- When the OVEN READY indicator light turns off, place the product to be cooked in the oven.
- Set the cooking Time by turning the COOK TIMER dial to the desired time.

During the Cook Cycle, The OVEN READY Indicator light will cycle on and off with the heating elements.

- When the COOK TIMER reaches “zero”, the alarm will sound.
- To cancel the alarm, turn the COOK TIMER dial to the OFF position.

## “X” Controller

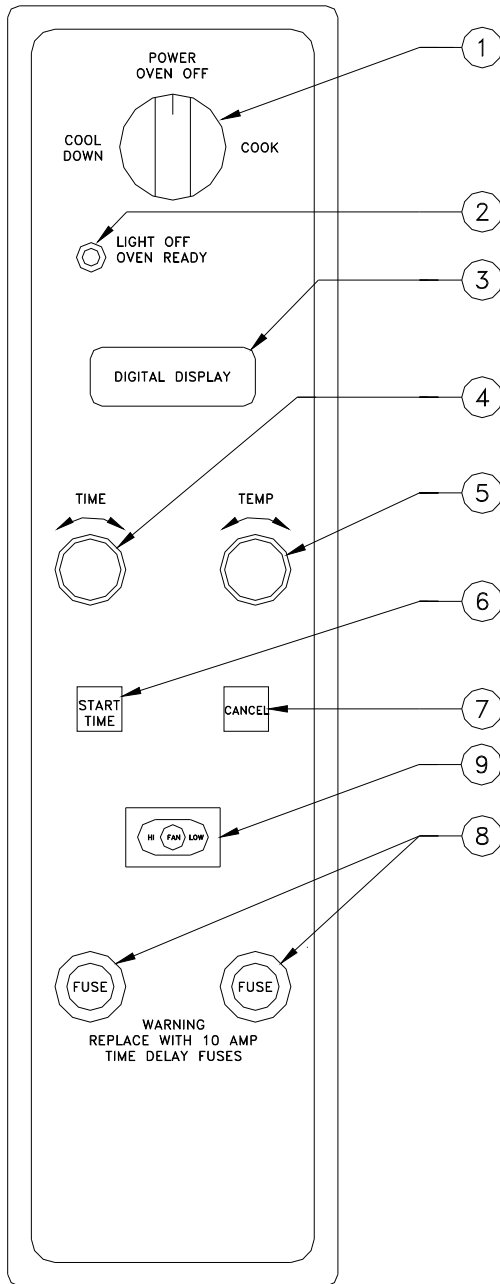

## Oven Controls – Solid State Digital Controls

- 1. **The Power Switch** – Controls power to ON or Cool Down function.
- 2. **The Indicator Light** – When lit indicates burners are operating. When the light goes out, the oven has reached its cooking temperature.
- 3. **The Digital Display** – Indicates time and/or temperature.
- 4. **The Time dial** – Sets countdown timer for cook cycle.
- 5. **The Temperature Dial** – Sets cooking temperature.
- 6. **The Start Time Button** – Initiates timing cycle.
- 7. **The Cancel Button** – Cancels preset time and/or temperature.
- 8. **The Fuse Holders** – Contain circuit protecting fuses.
- 9. **The Fan Speed Switch** (Optional) – Sets fan speed to high or low.

---

## PROGRAMMING & OPERATION

### INSTRUCTIONS FOR “X” CONTROLLER

#### Timer Resolution

The Timer displays time in two (2) different scales. From 0 to 60 minutes, the timer is displayed in Minutes/Seconds (“MN” Mode). From 1 to 12 hours, the time is displayed in Hours/Minutes (“HR” Mode). The mode indicators are located in the first number digit to the left of the colon.

#### Temperature Scale

The controller can be set to display toe temperature in °F or °C as follows:

- Turn Power Switch to COOK position.
- Set TIME to 00:00 and TEMP so “20” is displayed in the right two temperature digits.
- Press and hold both the START TIME and CANCEL buttons for 5 seconds. The control will display “CCC” and “FFF” in the temperature digits to indicate it has entered the mode.
- Turn the TIME or TEMP dial to toggle between “CCC” and “FFF”.
- Press CANCEL to exit.

#### Power Input Frequency

The controller can be set to operate on 50Hz or 60Hz as follows:

- Turn Power Switch to COOK position.
- Set TIME to 00:00 and TEMP so “40” is displayed in the right two temperature digits.
- Press and hold both the START TIME and CANCEL buttons for 5 seconds. The control will display “50” and “60” to indicate it has entered the mode.
- Turn the TIME or TEMP dial to toggle between “50” and “60”.
- Press CANCEL to exit.

#### Actual Temperature Button

The actual temperature can be viewed by pressing and holding the START TIME button for approximately 2 seconds. The temperature will be displayed in the temperature digits. This can be viewed anytime the oven is in operation, except when the oven is in the HOLD mode.

#### Pulse

The controller can be set to operate the fan continuously, or cycle on and off every 30 seconds during the COOK cycle as follows:

- Turn Power Switch to COOK position.
- Set TIME to 00:00 and TEMP to 000.

- Press and hold both the START TIME and CANCEL buttons for 5 seconds. The control will display “Con” or “CYC” to indicate it has entered the mode.
- Turn the TIME and TEMP dial to toggle between “Con:” and “CYC”.
- Press CANCEL to exit.

The fan cannot be set to cycle if the HOLD mode is to be used.

#### Fan Speed Switch

The fan speed can be set to high or low speed by placing FAN HI/LOW switch to the desired setting. The display does not indicate which mode the fan is operating.

#### Cool Down

This feature enables the oven to be cooled rapidly by allowing the fan to operate with the burners turned off. To activate, turn the Power Switch to the COOL position and open the oven door. When the door is opened enough to disengage the door switch, the fan will turn on. Closing the door will turn the fan off.

#### Cooking

A cooking cycle can be initiated as follows:

- Turn Power Switch to COOK position.
- Set the cooking time by turning the TIME dial until the desired time is shown on the display.
- Set the desired cooking temperature by turning the TEMP dial until the desired temperature is shown on the display. The indicator light will turn on and the display will flash when a minimum temperature of 150°F is entered. The flashing display indicates that the oven is in its Preheating Mode. It will no longer flash once the oven reaches the temperature set point. The indicator light will cycle on and off with the burners.
- Press the START TIME button to begin the timed cooking cycle. Pressing the CANCEL button will “zero” the timer at any time.

#### Cook & Hold

The controller can be set to hold the oven at a set temperature at the end of the cooking cycle as follows:

- Turn Power Switch to COOK position.
- Set TIME to 00:00 and TEMP so “50” is displayed in the right two temperature

---

digits.

- Press and hold both the START TIME and CANCEL buttons for 5 seconds. The control will display “HOLD” in the time digits, and the current Hold Set Temperature in the temperature digits to indicate it has entered the mode.
- Turn the TIME or TEMP dial to set the desired temperature. Setting it to “000” will turn the Hold mode off.
- Press CANCEL to exit.

When the timer counts down to zero, the alarm will sound for 5 seconds and “HOLD” will appear in the display with the current hold temperature. The timer will not count up. Manual timing is required.

### **Offset**

To compensate for the difference in temperature from the sensing element to the center of the oven the control can be programmed with an offset. The offset is adjustable in 1°F increments up to a maximum of ±49°F.

**Note:** a negative offset will have the effect of raising the cavity temperature, (Example: an oven set at 375°F is determined to run at a 350°F internal oven temperature. By programming in a -25°F offset the oven will run at a 375°F internal oven temperature.).

The offset is programmed as follows:

- Turn Power Switch to COOK position.
- Set TIME to 00:00 and TEMP so “10” is displayed in the right two temperature digits.
- Press and hold both the START TIME and CANCEL buttons for 5 seconds. The control will display “UPO” in the time digits, and the current Offset in the temperature digits to indicate it has entered the mode.
- Turn the TIME or TEMP dial to raise or lower the offset.
- Press CANCEL to exit.

## “XX” Control

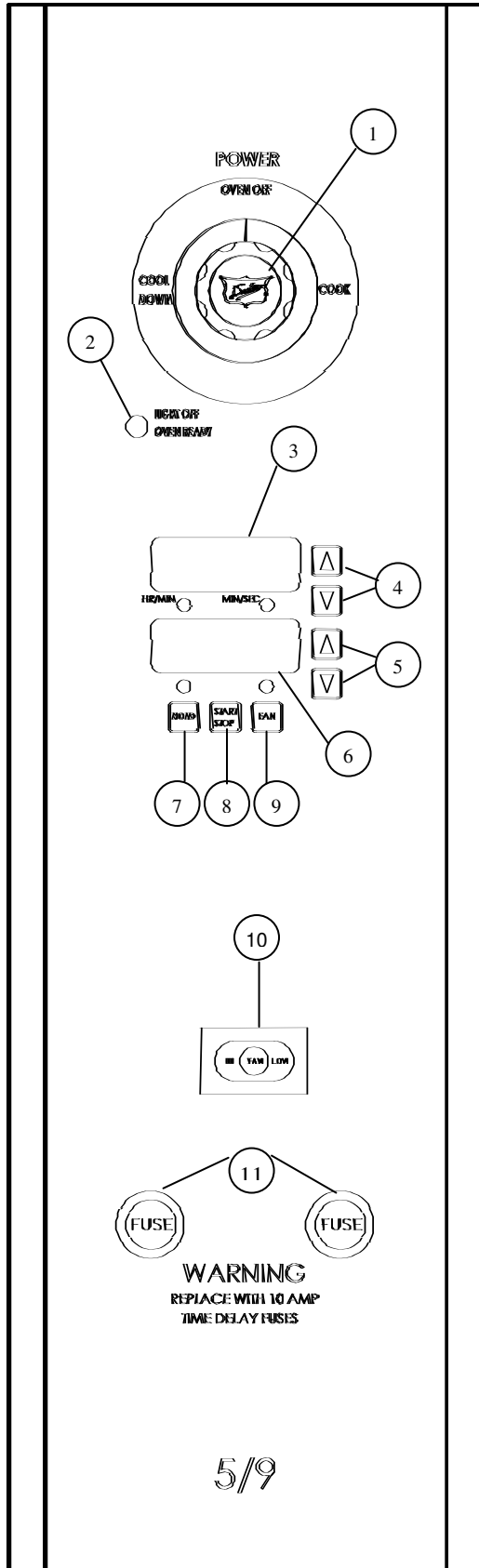

### Oven Controls – Solid State Digital Controls

- 1. **The Power Switch** – Controls Power to ON or Cool Down Function
- 2. **The Indicator Light** – When lit indicates burners are operating. When the light goes out, the oven has reached its cooking temperature.
- 3. **The Digital Display** – Indicates time and/or temperature.
- 4. **The Time Adjustment Buttons** – Sets/adjusts countdown timer for cook cycle.
- 5. **The Temperature Adjustment Buttons** – Sets/adjusts cooking Temperature.
- 6. **The Temperature Digital Display:** Displays the temperature inside the oven.
- 7. **The Pulse Fan Button:** Enables/Disables the Pulse Fan Function.
- 8. **The Start/Stop Button:** Starts/Stops the cooking cycle.
- 9. **The Hold Button:** Enables/Disables the Hold Function.
- 10. **The Fan Speed Switch:** (Optional) – Sets fan speed to high or low.
- 11. **The Fuse Holders:** Each holds a 10 AMP Time Delay Fuse.

### Programming and Operating Instructions – “XX” Controller

**Timer Scale:** The Timer displays in two (2) different scales. From 0 to 60 minutes, the timer is displayed in Minutes/Seconds. This is indicated by the MIN/SEC light on the controller. From 1 to 2 hours, the time is displayed in Hours/Minutes, indicated by the HOUR/MIN light on the controller. When the oven is first turned on, the display will show the last cook time programmed.

**Time Adjustment:** To increase the cook time, press the top (▲) button located next to the Time Display. To decrease the cook time, press the bottom button (▼) located next to the Time Display.

**Temperature Scale:** The controller can be set to display the temperature in °F or °C as follows:

- 1) Remove/move control panel so that you have access to the back of the control board.
- 2) Locate the blue jumper at connection J3.
- 3) For °F operation the jumper is not needed. Place the jumper on one of the pins for future use.
- 4) For °C operation place the jumper across the two pins of J3. When the oven is first turned on, the display will show the last cook temperature programmed. You can view the actual temperature of the oven by pressing both of the Temperature Adjustment buttons at the same time.

# “Z” Controller

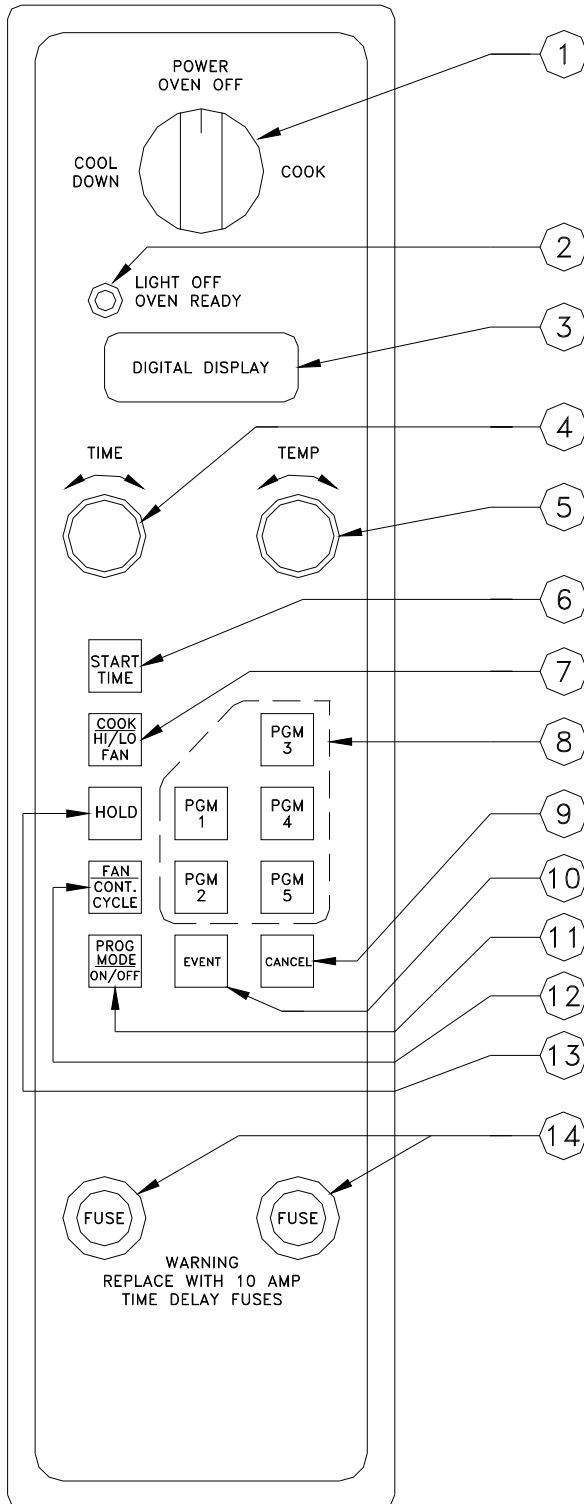

## en Controls – Solid State Digital Controls

- 1. **The Power Switch** – Controls power to ON or Cool Down function.
- 2. **The Indicator Light** – When lit indicates burners are operating. When the light goes out, the oven has reached its cooking temperature.
- 3. **The Digital Display** – Indicates time and/or temperature.
- 4. **The Time Dial** – Sets countdown timer for cook cycle.
- 5. **The Temperature Dial** – Sets cooking temperature.
- 6. **The Start Time Button** – Initiates timing cycle.
- 7. **The Cook/Hi-Lo Button** – Sets fan speed to high or low.
- 8. **The Program Button** – 5 individual time and temperature programs. Operator programmed.
- 9. **The Cancel Button** – Cancels preset time and/or temperature.
- 10. **The Event Button** – Used for programming oven functions that will be chained into one cooking routine.
- 11. **The Program Mode – ON/OFF** – Switches from Operating to Programming Mode and back.
- 12. **The Fan Continuous/Cycle Button** – Allows setting of fan to run continuously or turn on and off with the burners during the cooking cycle.
- 13. **The Hold Button** – Allows setting of hold time and temperature.
- 14. **The Fuse Holders** – Contain circuit protecting fuses..

---

## **PROGRAMMING & OPERATING INSTRUCTIONS“Z” CONTROLLER -**

This controller provides five (5) automatic cooking chains, which the user can program. It will also allow non-automatic cooking and cook & hold operations. The fan motor can be controlled to cycle on and off with the burners or run continuously. High or low fan speeds can be selected.

The cooking chains are particularly useful when the user is producing batches of the same product time after time, especially if changes to temperature or fan speed are required during the cooking cycle. The user can program one of the five program buttons for a particular product and simply press one button when it is loaded into the oven. The control will follow the programmed cooking routine changing temperature and/or fan speeds or fan cycle/continuous at the programmed intervals. Thus, once the cooking chain is programmed, the user would benefit from consistent results when cooking the same batch.

However, not all usage of the oven requires an automatic cooking routine. In these cases, the oven can be used in a normal manner where the times and temperatures are set using the rotary dials. A manual Cook & Hold is also available for holding a product after it has been cooked.

The following instructions will assist you in using this control with your oven, but if you have any questions you should contact the Duke Service Department on our toll free support line: **800.735.3853**.

### **Timer Resolution**

The Timer displays time in two different scales. From 0 to 60 minutes, the time is displayed in Minutes/Seconds (“MN” Mode). From 1 to 12 hours, the time is displayed in Hours/Minutes (“HR” Mode). The mode indicators are located in the first number digit to the left of the colon.

### **Power Input Frequency**

The controller will automatically set itself to operate on 50Hz or 60Hz, depending on the power source used. All timers and internal clocks are automatically compensated.

### **Temperature Scale**

The controller can be set to display the temperature in °F or °C. as follows:

- Turn Power Switch to COOK position.
- Set TIME to 00:00 and TEMP so “20” is displayed in the right two temperature digits.

Press and hold the START TIME button for 5 seconds.

The control will display “CCC” or “FFF” in the temperature digits to indicate it has entered the mode.

Entering will toggle between “CCC” and “FFF”. Pressing and holding the START TIME button again will also toggle the setting.

Turn Power Switch to OFF position to exit.

### **Time Dial**

The TIME dial sets time intervals for cooking. It is used in either programmed or manual cooking.

### **Temp Dial**

The TEMP dial sets the temperature. The temperature changes in 5°F or 1°C increments.

### **Start Time Button**

The START TIME button initiates the cooking cycle whether a programmed chain or manual time set with the TIME dial used.

### **Cook HI/LO Fan Button**

The COOK HI/LOW FAN button puts the control into a cook mode and enables the heating elements. Each time the button is pressed, the control switches between the high or low fan speeds. If neither fan is enabled, the high fan speed is selected automatically. The HI FAN and LO FAN indicators show, which fan speed, is selected.

### **Hold Button**

The HOLD button is used to set up the Hold Mode. The user presses the HOLD button and sets the desired temperature and continuous or cycled fan. During the Hold setup mode, the HOLD indicator is lit and the CYCLE indicator is lit if the cycled fan is selected.

During the cook portion hold mode, the timer counts down to zero. During the hold portion, the timer counts up from zero.

### **Fan Con/Cyc Button**

The FAN CON/CYC button enables the fan to run continuously during the cooking cycle, or run only when the control is calling for heat. The display will show FAN CYC when the cycled fan mode is selected and FAN CON when the continuous mode is selected. The CYCLE indicator will light when the cycled fan is enabled.

---

## Program Mode On/Off Button

This button allows the user to activate the programming mode. When this mode is selected, normal oven operation is suspended. The programming mode allows the user to program the cook chains. When this button is pressed again, the program mode is exited and normal oven operation is resumed. When the programming mode is entered the PGM indicators flash.

## Event # Button

During the programmed chain cooking operation, this button is used to recall the time remaining in the current event. In the programming mode, this button is used to sequence to the next event to be programmed. During manual operation, this button is disabled.

## Program Buttons (1-5)

The five (5) programming buttons are provided for chained cooking. Programs 1 and 2 provide the user with 6 events each, and programs 3, 4 and 5 provide 4 events each. The user sets the value programmed for each event. The Program buttons are locked out when the control is running a manual timed cook.

1 Event = time, temp, fan speed, fan mode.

## Cancel Button

The CANCEL button is provided to clear the timer and enable the program buttons and rotary dials. It also cancels the Programming Mode, the beeper, and turns off any indicators that are no longer needed.

## Power Up

On initial power up, the time digits will always display zeros with a colon. The temperature digits will display zeros with the degree (°) indicator lit. The C will also be lit in the display if the Celsius option is selected. When the control is turned off, the temperature/timer setting is stored. When the control is turned on again, it will automatically return to the last set time and temperature

## Cool Down

This feature enables the oven to be cooled rapidly by allowing the fan to operate with the heating elements turned off. To activate, turn the Power Switch to the COOL position and open the oven door. Then the door is opened enough to disengage the door switch, the fan will turn on. Closing the door will turn the fan off.

## Manual Cooking

A normal, non-programmed cooking cycle can be initiated as follows:

- Turn Power Switch to COOK position.
- Set the desired time using the TIME dial.
- Set the desired temperature using the TEMP dial.
- Select the desired fan speed using the COOK HI/LO FAN button.
- Select the fan to be on continuously or cycled using the FAN/ CON/CYC button.
- Set the HOLD temperature, if desired.
- Press the START TIME button to start the cooking cycle.
- Pressing the CANCEL button will “zero” the Timer at any time.

## Programmed Chain Cooking

With the control in normal operating mode, press the desired chain (PBM 1-5) button. If the selected chain has been programmed, the first event will be loaded. The timer will not start until the START TIME button is pressed. The oven temperature will be controlled to the temperature programmed to the first event.

## Chain Programming

Each of the 5 PGM buttons can be programmed to perform a different sequence or “chain” of events. Each event, or step, includes a setting for the time, temperature, fan speed, and fan mode. **PGM 1** and **PGM 2** allow the user to set up to **6 events** to be performed during the cooking cycle, while **PGM 3**,

**PGM 4** and **PGM 5** allow up to **4 events**. The **last** event for any of the Programmed Chains can be set to be a Hold mode. Programming the PGM buttons is performed as follows:

- Turn Power Switch to **COOK** position.
- Press the **PGM MOD ON/OFF** button to enter the programming mode. All PGM indicators will flash and the balance of the display will be blanked.
- At this time, one of the **PGM Button’s (1-5)** must be pressed to select which chain is to be programmed. When the desired PGM button is pressed, the appropriate PGM indicator will remain flashing and event 1 time and temperature will be displayed. The event number (**E1-E6**) will be displayed alternately with the temperature digits.

- 
- To change the event time, turn the **TIME** dial. The time entered will be displayed in the time digits.
  - To change event temperature, turn the **TEMP** dial for the desired set temperature. The temperature entered will be displayed in the temperature digits. The event number display will not be shown while the **TEMP** dial is being rotated.
  - To change the fan speed, press the **COOK HI/LO FAN** button. The display indicators will show the selected cook mode.
  - Press the **FAN CON/CYC** button to select continuous or cycled fan. The display will show **FAN CON** or **FAN CYC** to indicate which mode is selected. The **CYCLE** indicator will light if the cycled fan is enabled.
  - To set up a hold mode, press the **HOLD** button. The **HOLD** indicator will be lit when this mode has been selected.

**When an event is programmed as a Hold, that event will be the last recognized event of the chain. As an example, if Event 3 is set up as a Hold and Event 4 was set up as a Cook, Event 4 would be ignored.**

- To exit the Programming mode, press the **PGM ON/OFF** or **CANCEL** button. The programmed parameters of the previously programmed chain will be saved at this time.
- To program another event within the same chain, press the **EVENT #** button. The parameters of the previous event are saved at this time and sequential event will be displayed. If the previous event was the last of the chain, the first event will be displayed.
- To program another chain, press the desired **PGM BUTTON (1-5)**. Event 1 of the selected chain will be displayed and the parameters of the previously programmed chain will be saved at this time.

#### **EXAMPLE: MUFFINS**

**Event 1:** Cook temp - 400°F, LOW fan speed, cycled fan, cook time = 4 minutes

Cycled, low fan allows the muffins to rise and skin over without being distorted by the air movement.

**Event 2:** Cook temp = 400°F, HIGH fan speed, continuous fan, cook time = 8 minutes.

Once the product is skinned over, the continuous, high-speed fan will finish the cooking.

**TOTAL COOK TIME = 12 MINUTES**

(This is an example; your results may vary.)

## “ZX” Controller

## Oven Controls – Solid State Digital Control with Rack Timer Capability.

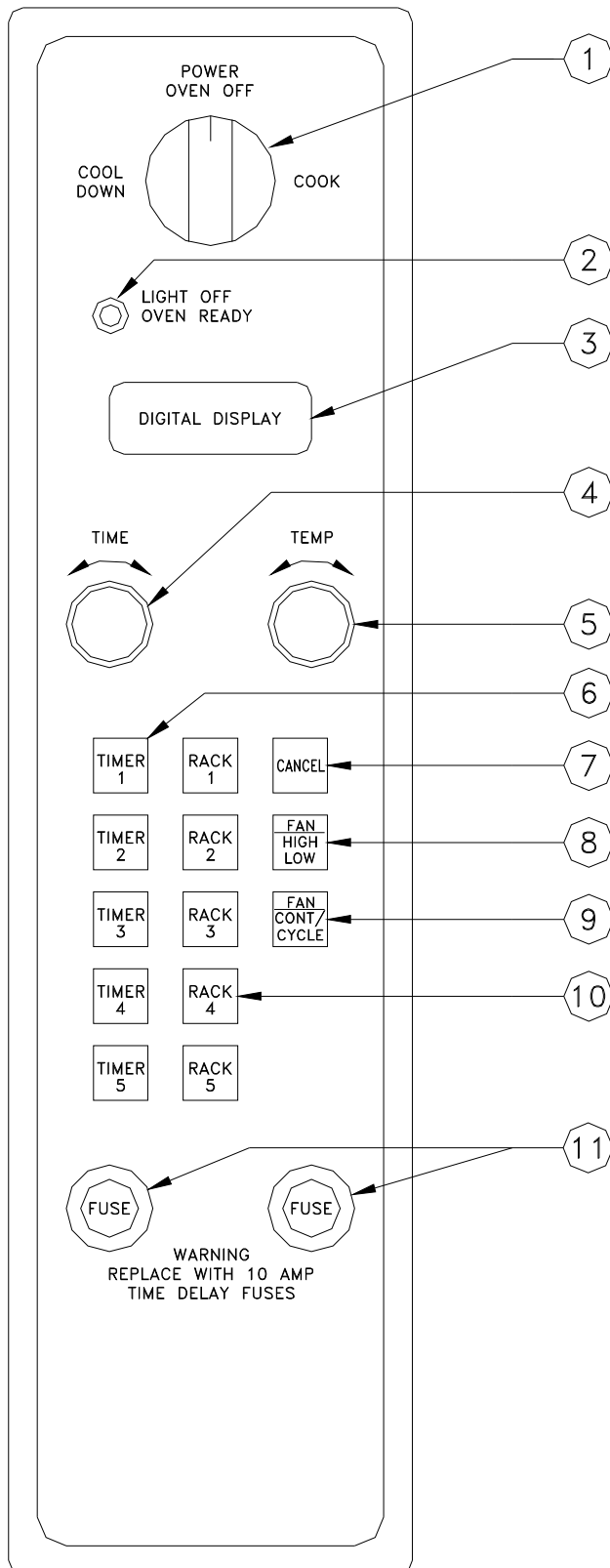

- 1. **The Power Switch** – Controls power to ON or Cool Down function.
- 2. **The Indicator Light** – When lit indicates burners are operating. When the light goes out, the oven has reached its cooking temperature.
- 3. **The Digital Display** – Indicates time and/or temperature.
- 4. **The Time Display** – Sets countdown timer for cook cycle.
- 5. **The Temperature Dial** – Sets cooking temperature.
- 6. **The Timer Selector Buttons** – Used to select which timer will be used for the product to be cooked.
- 7. **The Fan HI-LO Button** – Sets fan speed to high or low.
- 8. **The Cancel Button** – Cancels preset time and/or temperature.
- 9. **The Fan Continuous/Cycle Button** – Allows setting of fan to run continuously or turn on and off with the burners during the cooking cycle.
- 10. **The Rack Selector Buttons** – Allows setting of fan to run continuously or pulse on and off during the cooking cycle.
- 11. **The Fuse Holders** – Contain circuit protecting fuses.

---

## Programming & Operating Instructions

### “ZX” Controller

#### Timer Resolution

The Timer displays time in two different scales. From 0 to 60 minutes, the time is displayed in Minutes/Seconds (“MN” Mode). From 1 to 12 hours, the time is displayed in Hours/Minutes (“HR” Model). The mode indicators are located in the first number digit to the left of the colon.

#### Temperature Scale

The controller can be set to display the temperature in °F or °C as follows:

- Turn Power Switch to **COOK** position.
- Set **TIME** to 00:00 and **TEMP** so “20” is displayed in the right two temperature digits.
- Press and hold the **START TIME** button for 5 seconds. The control will display “CCC” or “FFF” in the temperature digits to indicate it has entered the mode.
- Entering will toggle between “CCC” and “FFF”. Pressing and holding the **RACK 1** button again will also toggle the setting.
- Turn Power Switch to **OFF** position to exit.

#### Power Input Frequency

The controller will automatically set itself to operate on 50Hz or 60Hz, depending on the power source used. All timers and internal clocks are automatically compensated.

#### Timed Dial

The **TIME** dial sets time intervals for cooking. It is used in either programming or manual cooking.

#### Rack Buttons (1-5)

The five (5) Rack Buttons are provided to allow up to 5 individual shelves, or racks, to be timed at different intervals. The shelves can be selected in any order. The temperature setting must be the same for each rack button.

#### Temp Dial

The **TEMP** dial sets the temperature. The temperature changes in 5°F or 1°C increments.

#### Fan High Low Button

The **FAN HIGH LOW** Button puts the control into a cook mode and enables the heating elements. Each time the button is pressed, the control switches between the high or low fan speeds. If neither fan is enabled, the high fan speed is selected automatically. The **HI FAN** and **LO FAN** indicators show, which fan speed, is selected.

#### Fan Con/Cycle Button

The **FAN CONT/CYCLE** Button enables the fan to run continuously during the cooking cycle, or run only when the control is calling for heat. The display will show **FAN CYC** when the cycled fan mode is selected and **FAN CON** when the continuous mode is selected. The **CYCLE** indicator will light when the cycled fan is enabled.

#### Time Selector Buttons (1-5)

The five (5) Timer Buttons are provided to allow up to 5 different preset time intervals to be programmed. When a Time button is pressed, its timed setting will be recalled and displayed in the time digits.

#### Cancel Button

The **CANCEL** Button is provided to clear the End of Cycle beeper or “zero” a non-running timer. A running timer can be cancelled by pressing the selected Rack button to recall the timer and then pressing the **CANCEL** button within 3 seconds.

#### Cool Down

This feature enables the oven to be cooled rapidly by allowing the fan to operate with the heating elements off. To activate, turn the Power Switch to the **COOL** position and open the oven door. When the door is opened enough to disengage the door switch, the fan will turn on. Closing the door will turn the fan off.

#### Power Up

On initial power up, the time digits will always display zeros with a colon. The temperature digits will display zeros with the degree (°) indicator lit. The C will also be lit in the display if the Celsius option is selected. When the control is turned off, the temperature/timer setting is stored. When the control is turned on again, it will automatically return to the last set time and temperature.

#### Timer Buttons

Each of the **TIMER** buttons can be programmed to a different setting. Pressing and holding a **TIMER** button and setting the timer dial to the desired setting programs them. When the **TIMER** button is released, the displayed time is saved.

#### Manual Cooking

A normal cooking cycle where the entire product to be cooked is placed in the oven at once can be initiated as follows:

- Turn Power Switch to **COOK** position
- Set the desired temperature using the **TEMP** dial.
- Select the desired fan speed using the **COOK HI/LO FAN** button.
- Select the fan to be on continuously or cycled using the **FAN CON/CYC** button.
- Set the desired time using the **TIME** dial or selecting one of the preset **TIMER** buttons.
- Press one of the **RACK** buttons to start the cooking cycle. The timer will begin to count down and the

---

selected Racks indicator will begin flashing.

- Pressing the selected **RACK** button and then the **CANCEL** button within 3 seconds will “zero” the Timer at any time.
- The Alarm will sound at the end of the cooking cycle. Pressing the **CANCEL** or selected **RACK** button will cancel it.

### **Timed Shelf Cooking**

A cooking cycle where the product to be cooked is placed in the oven one pan or shelf at a time can be initiated as follows:

- Turn Power Switch to COOK position.
- Set the desired temperature using the TEMP dial.
- Select the desired fan speed using the COOK HI/LO FAN button.
- Select the fan to on continuously or cycles using the FAN CON/CYC button.
- Place pan on first shelf.
- Set the desired time using the TIME dial or selecting one of the preset TIMER buttons.
- Press the RACK 1 button to start the cooking cycle. The timer will begin to count down and the RACK 1 indicators will begin flashing.
- Pressing the selected RACK button and then CANCEL button within 3 seconds will “zero” the Timer at any time.
- Place the next pan on second shelf.
- Set the desired time using the TIME dial or selecting one of the preset TIMER buttons.
- Press the RACK 2 button. The RACK 2 indicator will light. The Time will resume counting down.

The procedure of placing a pan on a shelf, selecting the desired time, and pressing the corresponding RACK button can be repeated for a total of 5 Shelf/Rack combinations.

- When RACK 1 reaches “zero”, the alarm will sound and “-1-“ will be flashing in the display. Pressing CANCEL or RACK 1 button will cancel it.
- After the alarm is cancelled, the Timer will display the remainder of the countdown for the RACK with the least amount of time left and its indicator will begin flashing.

This will be repeated until all of the RACK Timers reach “zero”.

## “ZZ” Controller

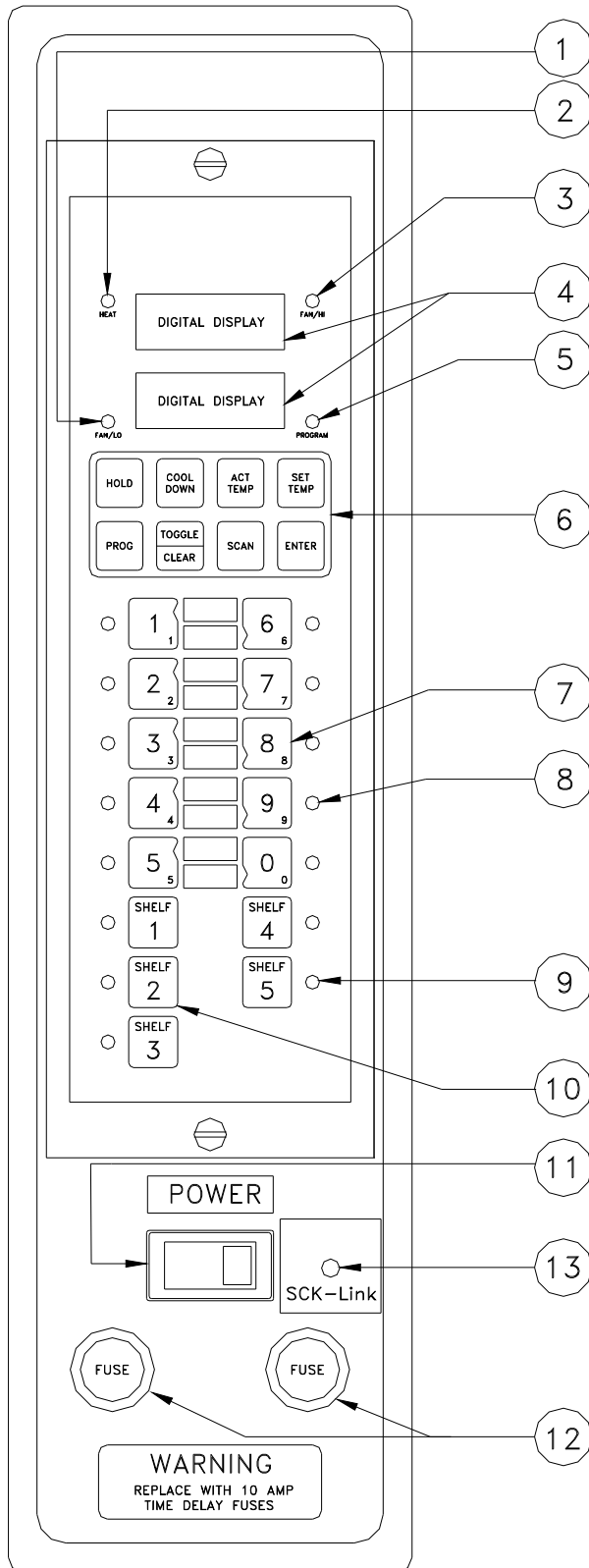

## Oven Controls – Electronic Control with Computerized Profile Baking

- 1. **The Fan/Lo Indicator LED** – Lights when the fan speed is set to low
- 2. **The Heat Indicator LED** – Lights when the oven is in the Heat Mode.
- 3. **The Fan/Hi Indicator LED** Lights when the fan speed is set to high.
- 4. **The Digital Display** – Indicates time and/or temperature.
- 5. **The Program Indicator LED** – Lights when the controller is in the Programming Mode.
- 6. **The Programming Buttons** – These buttons are used to enter the Programming Mode, create a cooking profile, and exit the Programming Mode.
- 7. **The Product Selector Buttons** – 10 individual cooking profiles. Operator programmed.
- 8. **The Product Selection Indicator LEDs** – Lights when the oven has reached the temperature set for the corresponding Product Selection Button.
- 9. **The Shelf Indicator LEDs** – Lights when the corresponding Shelf Button is active.
- 10. **The Shelf Selector Buttons** – Used to select which shelf the pan will be cooked on.
- 11. **The Power Switch** – Controls power to ON or OFF.
- 12. **The Fuse Holders** – Contain circuit protecting fuses.
- 13. **The SCK-LINK Port (Optional)** – Used to program the controller using the external module.

---

## Programming & Operating Instructions "ZZ" Controller

The controller provides ten automatic Product Selection, or Recipe, Buttons that the user can program himself. The Product Selection Buttons are particularly useful when the user is producing batches of the same product time after time, especially if changes to temperature or fan speed are required during the cooking cycle. The user can program one of the ten buttons for a particular product and simply press one button when it is loaded into the oven. The control will follow the programmed cooking routine, changing temperatures and/or fan speeds or fan cycle/continuous at the programming intervals. Thus, once the cooking chain or profile is programmed, the user would benefit from consistent results when cooking the same batch.

The controller has three modes of operation:

- Operating
- System Programming
- Product Selection Button Programming

The following instructions will assist you in using this control with your oven, but if you have any questions you should contact the Duke Service Department on our toll free support line:

**(800) 735-3853**

### Timer Resolution

The operator has the ability to program the cook times for each product button. The controller is programmable in hours (18), minutes (up to 59), and seconds (up to 59).

### Power Input Frequency

The controller will automatically set itself to operate on 50Hz or 60Hz, depending on the power source used. All timers and internal clocks are automatically compensated.

### Temperature Scale

The controller can be set to display the temperature in °F or "C from the System Programming Mode.

### Actual Temperature Button

The actual temperature inside the oven can be displayed by pressing the **ACT TEMP** button.

### Temperature Setting

The operator has the ability to program the cook temperatures for each product button. The valid temperature range is 100" to 450°F (38° to 232°C).

### Set Temperature Button

The current programmed temperature for the oven can be displayed by pressing the **SET TEMP** button.

### Hold Button

The Hold feature can be accessed either manually or automatically. A manual hold can be initiated and cancelled by pressing the **HOLD** button. The time (up to 9 hours), fan speed (high or low), and temperature (140° - 210°F) are programmed in the **System Programming Mode**.

An automatic Hold can be set for each Product Selection Button and can be programmed in the **Product Selection Programming Mode**. The time (up to 9 hours), fan speed (high or low), and temperature (140° - 210°F) are programmable. Pressing the **HOLD** button at the end of the cooking cycle cancels the Hold mode and alarm.

### Scan Button

The **SCAN** button is used during Programming to move from one function to the next.

### Enter Button

The **ENTER** button is used during Programming to advance to the next profile setting for the same function.

### Toggle/Clear Button

The **TOGGLE/CLEAR** button is used during the Programming of the controller. It will either toggle between the options or clear the current settings while programming the Product Selection buttons.

### Programming Button

The **PROG** button is used to enter and exit both the System and Product Selection Button Programming Modes.

### Cool Down Button

This feature enables the oven to be cooled rapidly by allowing the fan to operate with the heating elements turned off. To activate, press the **COOL DOWN** button and open the oven door. Press the **COOL DOWN** button again to cancel.

### Operating Mode

The Operating Mode is used to cook the various menu items. When the Power Switch is turned on, the oven will begin to heat up. As it reaches the various cooking temperatures set on the Product Selection buttons, the corresponding LED for the Product Selection button will light up. This notifies the operator that the oven is ready for use with that recipe.

### Automatic Cooking

A cooking cycle where all of the product to be cooked at once can be initiated as follows:

- Turn the Power Switch on. The LED(s) for the Recipe button(s) with the lowest cook temperature will light up and the oven will automatically start to heat up to that temperature. The top display will show the actual oven temperature. The bottom display will indicate whether the current temperature is above (**HI**) or below (**Lo**) that temperature.
- If the LED for the desired Recipe button is not lit, press the button. The LED will light up. As the oven heats up to the set temperature for the Recipe button, the actual oven temperature will be shown in the top display and Lo in the bottom display. (If the wrong Recipe button was pressed, holding it down for 3 seconds will cancel it at any time.)
- After the oven reaches the set temperature for that Recipe, an audible beep will sound and **rEdY** will be shown in the display.
- Place the product to be cooked into the oven.
- Press the Recipe button again. The display will start counting down and the Recipe button LED will begin flashing rapidly.
- When the cooking cycle is completed, the alarm will sound and the Recipe LED will flash in sequence with the display. Press the Recipe button to cancel it.
- If a Hold mode is programmed on the Recipe button, it will start counting up when the completed alarm is canceled.
- When the Hold cycle is completed, the alarm will sound. Pressing the **HOLD** button will cancel it

## Timed Shelf Cooking

A cooking cycle where the product to be cooked is placed in the oven one pan or shelf at a time can be initiated as follows:

- Turn the Power Switch on. The LED(s) for the Recipe button(s) with the lowest cook temperature will light up and the oven will automatically start to heat up to that temperature. The top display will show the actual oven temperature. The bottom display will indicate whether the current temperature is above (**Hi**) or below (**Lo**) that temperature.
- If the LED for the desired Recipe button is not lit, press the button. The LED will light up. As the oven heats up to the set temperature for the Recipe button, the actual oven temperature will be shown in the top display and Lo in the bottom display. (If the wrong Recipe button was pressed, holding It down for 3 seconds will cancel it at any time.)
- After the oven reaches the set temperature for that Recipe, an audible beep will sound and **rEdY** will be shown in the display.
- Press the Recipe button again. The Recipe button LED will turn off and the 5 Shelf button LED's will light up.
- Place the first pan of product to be cooked in the oven on the desired rack.

- Press the corresponding **SHELF** button. The LEDs for the Recipe and **SHELF** button will start flashing rapidly, the unused **SHELF** buttons' LEDs will turn off, and the display will begin to count down to zero.
- Place the second pan of product to be cooked in the oven on the desired rack.
- Press the Recipe button and then the corresponding **SHELF** button. The LED for the Shelf button will light up and the display will continue to count down to zero.

The procedure of placing a pan on a shelf, pressing the Recipe button, and pressing the corresponding **SHELF** button can be repeated for a total of 5 Shelf/Rack combinations.

- When the cooking cycle is completed, the alarm will sound and the Recipe and Shelf button LEDs will flash in sequence with the display. Press the **SHELF** button to cancel it.
- After the alarm is cancelled, the LEDs for the Recipe and **SHELF** buttons with the least amount of time remaining will start flashing rapidly and the display will continue to count down to zero.

This will be repeated until all of the Shelf Timers reach "zero".

## Programming the Controller

The controller uses 2 displays to show information during operation and programming. When a "display" is described in the instructions, it will include whether it will be shown in the top or bottom display.

The **ENTER** button is used to advance to the next profile for the same setting.

The **SCAN** button is used to complete the programming for that setting and advance to the next setting or function.

Each of the Product Selection buttons can be programmed to perform up to six (6) cooking chains or profiles. A **profile** consists of:

Cook Time Setting Cook Temperature Setting Fan Speed Setting Fan Mode Setting Timing Mode Setting Shelf ID Setting Hold Yes/No Setting Hold Time Setting Hold Temperature Setting Hold Fan Speed Setting

If more than one profile is used for programming a Product Selection button, the same setting must be set for each profile. For example, all of the cook times must be set before moving on to the cook temperatures.

If a Product Selection button is to be used with the Shelf buttons as a Rack or Shelf Timer, it may only have one profile.

## Setback

---

This feature automatically cools the oven to a programmed temperature after a set amount of time has elapsed without a product or hold command being initiated. The operator is able to program the setback temperature (140° - 300°F) and setback time frame (max. 59 min759 sec.) when in the System Programming Mode.

### Programmable Timing Mode

The operator can program the Timing Mode (flex, straight or sensitivity) for each of the Product Selection Buttons. If flex time is selected, the controller will adjust the actual Cook Time taking into consideration the temperature variation due to load size. Initial product temperature, product moisture content, and other factors affecting the cook cycle, to insure the controller provides consistent, high-quality product.

If straight time is selected, the controller will cook only for the specified time without adjusting for these variations.

If sensitivity time is selected, the operator will be able to set a level (0-9) which will adjust the actual cook time based on temperature curve.

### Product Selection Button Programming Mode

The programming mode is entered as follows:

- Press the **PROG** button. **Code** will be shown in the top display.
- Enter the code "3124".
- Press the **ENTER** button. **Prod** will be shown in the top display.

The controller is now in the **Product Selection Button Programming Standby Mode**. The user is ready to program the **Product Selection Buttons**. For clarity, the displays will be identified as top and bottom. The individual buttons are programmed as follows:

- Press the 1 button. **Prod** will be shown in the top display and 1 in the bottom display.
- Press the **ENTER** button. **P1** (Profile #1) will be shown in the top display and the current **Cook Time Setting** in the bottom display.

### Cook Time Setting:

- To change the setting, press the **TOGGLE/CLEAR** button. **":0"** will be shown in the top display.
- Enter the new **Cook Time Setting**.
- Press the **ENTER** button if you wish to add an additional profile. **P2** (Profile #2) will be shown in the top display and the current **Cook Time Setting** in the bottom display. Repeat the steps from pressing the **TOGGLE/CLEAR** button to set the Cook Time for each additional profile. (Multiple profiles cannot be used if the Shelf ID is to be used.)

### Cook Temperature Setting:

- Press the **SCAN** button to move on to the **Cook Temperature Setting**. **Ct-1** will be shown in the top display and current **Cook Temperature Setting** in the bottom display.
- To change the setting, press the **TOGGLE/CLEAR** button. **Ct-1** will be shown in the top display and **OF** in the bottom display.
- Enter the new **Cook Temperature Setting**. **CM** will be shown in the top display and the new temperature setting in the bottom display.
- Press the **ENTER** button if you wish to add an additional Cook Temperature. **Ct-2** will be shown in the top display and the current **Cook Temperature Setting** in the bottom display. Repeat the steps from pressing the **TOGGLE/CLEAR** button to set the Cook Temperature for each additional profile.

### Fan Speed Setting:

- Press the **SCAN** button to move on to the **Fan Speed Setting**. **SPd1** will be shown in the top display and the current **Fan Speed Setting** in the bottom display.
- To change the setting, press the **TOGGLE/CLEAR** button. **SPd1** will be shown in the top display and **Hi** or **Lo** in the bottom display.
- Press the **ENTER** button if you wish to change Fan Speeds. **SPd2** will be shown in the top display and current **Fan Speed Setting** in the bottom display. Repeat the steps from pressing the **TOGGLE/CLEAR** button to set the Fan Speed for each additional profile.

### Fan Mode Setting:

- Press the **SCAN** button to move on to the **Fan Mode Setting**. **CYC1** will be shown in the top display and the current **Fan Mode Setting** in the bottom display. There are three Fan Modes to choose from: **PULS** (programmable fan on and off time), **HEAt** (fan on only with heat), and **FULL** (continuous fan).

The **PULS** feature will not activate until the oven has reached the set operating temperatures.

- To change the setting, press the **TOGGLE/CLEAR** button until the desired setting is shown in the bottom display and **CYC1** in the top display.
- If the **PULS** option was chosen, press the **SCAN** button to set the **ON** time. **on-1** will be shown in the top display and the current **ON** time in the bottom.
- To change the setting, press the **TOGGLE/CLEAR** button. **"A"** will be shown in the top display.
- Enter the new fan **ON** time.

- Press the **SCAN** button to set the **OFF** time. **oF-1** will be shown in the top display and the current **OFF** time in the bottom.
- To change the setting, press the **TOGGLE/CLEAR** button. ":0" will be shown in the top display.
- Enter the new fan **OFF** time.
- Press the **ENTER** button if you wish to add an additional Fan Mode. **CYC2** will be shown in the top display and the current **Fan Mode Setting** in the bottom display. Repeat the steps from pressing the **TOGGLE/CLEAR** button to set the Fan mode for each additional profile.

### Timing Mode Setting:

- Press the **SCAN** button to move on to the **Timing Mode Setting**. **tCI** will be shown in the top display and the current **Timing Mode Setting** in the bottom display. There are three Timing Modes to choose from: **St** (straight time), **FL** (flex time), and **SEnS** (sensitivity time). (See Programming Timing Mode for further definition.)
- To change the setting, press the **TOGGLE/CLEAR** button until the desired setting is shown in the bottom display and **tC1** in the top display.
- If the **SEnS** option was chosen, press the **SCAN** button to set the sensitivity level. **SEnS** will be shown in the top display and the current level in the bottom.
- To change the setting, press the **TOGGLE/CLEAR** button. **SEnS** will be shown in the top display and 0 in the bottom display.
- Enter the new sensitivity level.
- Press the **ENTER** button if you wish to add an additional Timing Mode. **tC2** will be shown in the top display and the current **Timing Mode Setting** in the bottom display. Repeat the steps from pressing the **TOGGLE/CLEAR** button to set the Timing Mode for each additional profile.

### Shelf ID Setting:

- Press the **SCAN** button to move on to the **Shelf ID Setting**. **SHLF** will be shown in the top display and **YES** or **no** in the bottom display. **YES** is used to indicate that the feature is **ON** and **no** to indicate it is **OFF**. (Shelf ID is not allowed if multiple profiles are used.)
- To change the setting, press the **TOGGLE/CLEAR** button until the desired setting is shown in the bottom display and **SHLF** in the top display. The Shelf setting is the same for the entire Product Button.

### Hold Setting (Automatic):

- Press the **SCAN** button to move on to the **Hold**

**Setting**. **HoLd** will be shown in the top display and **YES** or **no** in the bottom display. **YES** is used to indicate that the feature is **ON** and **no** to indicate it is **OFF**

- To change the setting, press the **TOGGLE/CLEAR** button until the desired setting is shown in the bottom display and **HoLd** in the top display.
- If the **YES** option was chosen, press the **SCAN** button to set the **Hold Time Setting**. **HoLd** will be shown in the top display and the current Hold Time in the bottom.
- To change the setting, press the **TOGGLE/CLEAR** button. ":0" will be shown in the bottom display.
- Enter the new Hold Time (up to 9 hours).
- Press the **SCAN** button to set the **Hold Temperature Setting**. **HoLd** will be shown in the top display and the current temperature in the bottom.
- To change the setting, press the **TOGGLE/CLEAR** button. **HoLd** will be shown in the top display and **OF** in the bottom display.
- Enter the new Hold Temperature (140° - 210°F).

### Hold Fan Speed Setting:

- Press the **SCAN** button to set the **Hold Fan Speed Setting**. **HFA**n will be shown in the top display and **Hi** or **Lo** in the bottom.
- To change the setting, press the **TOGGLE/CLEAR** button. **HFA**n will be shown in the top display and **Hi** or **Lo** in the bottom.
- Press the **SCAN** button. **Prod** will be shown in the top display. This indicates that the programming has been completed for the current Product Selection Button and ready for the next one to be selected.
- Press the **PROG** button to exit the **Programming Mode**.

### System Programming Mode

The System Programming Mode is used to program the following features:

- Manual Hold on/off and settings
- Setback on/off and settings
- Temperature Scale
- Appliance Type

The Programming mode is entered as follows:

- Press the **PROG** button. **Code** will be shown in the top display.
- Enter the code "**4512**".
- Press the **ENTER** button. **SYS** will be shown in the top display.

---

## Manual Hold Setting:

- Press the SCAN button to move on to the **Hold Setting**. **HoLd** will be shown in the top display and **YES** or **no** in the bottom display. **YES** is used to indicate that the feature is **ON** and **no** to indicate it is **OFF**.
- To change the setting, press the **TOGGLE/CLEAR** button until the desired setting is shown in the bottom display and **HoLd** in the top display.
- If the **YES** option was chosen, press the **SCAN** button to set the **Hold Time Setting**. **HoLd** will be shown in the top display and the current **Hold Time** in the bottom.
- To change the setting, press the **TOGGLE/CLEAR** button. **":0"** will be shown in the bottom display.
- Enter the new Hold Time (up to 9 hours).
- Press the **SCAN** button to set the **Hold Temperature Setting**. **HoLd** will be shown in the top display and the current temperature in the bottom.
- To change the setting, press the **TOGGLE/CLEAR** button. **HoLd** will be shown in the top display and **OF** in the bottom display.
- Enter the new Hold Temperature (140° - 210°F).

## Manual Hold Fan Speed Setting:

- Press the **SCAN** button to set the **Hold Fan Speed Setting**. **HFA**n will be shown in the top display and **Hi** or **Lo** in the bottom.
- To change the setting, press the **TOGGLE/CLEAR** button. **HFA**n will be shown in the top display and **Hi** or **Lo** in the bottom.

## Setback Setting:

- Press the **SCAN** button to move to the **Setback Setting**. **SEtb** will be shown in the top display and **YES** or **no** in the bottom display. **YES** is used to indicate that the feature is **ON** and **no** to indicate it is **OFF**.
- To change the setting, press the **TOGGLE/CLEAR** button until the desired setting is shown in the bottom display and **SEtb** in the top display.
- If the **YES** option was chosen, press the **SCAN** button to set the **Setback Time Setting**. **SEtb** will be shown in the top display and the current **Setback Time** in the bottom.
- To change the setting, press the **TOGGLE/CLEAR** button. **":0°"** will be shown in the bottom display.
- Enter the new Setback Time (up to 59 min./59 sec.).
- Press the **SCAN** button to set the **Setback Temperature Setting**. **SEtb** will be shown in the top display and the current temperature in the bottom.
- To change the setting, press the **TOGGLE/CLEAR** button. **SEtb** will be shown in the top display and

**OF** in the bottom display.

- Enter the new Setback Temperature (140° - 210°F).
- Press the **SCAN** button to set the **Temperature Scale**. **de9** will be shown in the top display and **F** or **C** in the bottom.
- To change the setting, press the **TOGGLE/CLEAR** button until the desired setting is shown in the bottom display.

## Appliance Mode Setting:

- Press the **SCAN** button to set the **Appliance Mode**. **APPL** will be shown in the top display and **ELEC** or **9AS** in the bottom display.
- To change the setting, press the **TOGGLE/CLEAR** button until the desired setting is shown in the bottom display.
- Press the **SCAN** button. **SYS** will be shown in the top display. Press the **PROG** button to exit the **System Programming Mode**.

---

## B. GENERAL GUIDELINES FOR OPERATION

These guidelines are to assist you in obtaining the best performance from your oven:

- Always pre-heat your oven before cooking by placing the temperature setting at the desired temperature. The oven is pre-heated when the Indicator Light goes out.
- Always use a lower temperature setting than that recommended for a standard conventional oven or range oven. The general rule of thumb is to subtract 50 - 100°F from the standard oven recipe. Some experimentation on your part may be necessary to achieve the optimum results with your food products.

**Cooking at higher temperatures will not reduce your cooking time! It will produce unsatisfactory baking and roasting results.**

- You should begin checking the doneness of your food product in about half the time recommended for the same recipe cooked in a standard oven. There is a Suggested Time and Temperature Chart on the next page, which can serve as a guide. Keep in mind that your times may vary depending on the amount of product being cooked in your oven. The best results are always achieved when a systematic record of times and temperatures is kept for reference.
- The oven will hold up to thirteen 18" x 26" (457mm x 660mm) sheet pans. Your product and pan height will determine how many racks can be loaded.

**Do not place an empty sheet pan or aluminum foil on the bottom of the oven. This will disrupt the airflow and cause uneven cooking results.**

- To minimize the shrinkage of roasted meats, place the meat directly on the racks and place a sheet pan one half full of water in the bottom rack position. The water will keep the oven compartment more humid and the meat juices will evaporate less.
- Maintain equal loads when cooking more than one pan of product at a time. You may wish to weigh the product to assure that the pan loads are equal. Smaller loads in one pan will cook at a different rate than larger ones in another.
- You may wish to experiment with leaving the oven OFF after pre-heating the oven and loading

when baking light products such as light cake batter or custard so the product will have time to set. Normally, 7-10 minutes with the oven OFF, then finishing with the oven ON, will keep the product from rippling or being pushed by the fan.

- When starting off with frozen product, you may wish to pre-heat your oven up to 100° F above the temperature you are going to cook. Load the product and reset the temperature for the normal time.
- For longer bulb life, do not leave the oven lights on when not viewing the product.

## OPERATION INSTRUCTIONS

The information in this section is intended for the use of qualified operating personnel. Qualified Operating Personnel are those individuals who have carefully read the information contained in this manual, are familiar with the function of the oven and/or have had experience with operating the equipment described. We recommend following these instructions to insure optimum performance, long life and trouble-free service from your oven.

### The 5/9 Electric Convection Ovens

Convection cooking has been around from the 1960s. Its advantages are well known. It differs from conventional cooking by the movement of heated air within the cooking cavity by means of a fan. This moving, heated air helps to strip the cool air from around the product being cooked, allowing the heat to penetrate more rapidly. The results are that your product is cooked quicker and at a lower temperature with the comparable product quality found in conventional ovens.

Please take the time to carefully read the operating instructions. They are important in the successful use of your oven.

### C. Suggested Times & Temperatures

	PRODUCT	°F	°C	COOK TIME	RACKS	TEMP	TIME
BEEF	HAMBURGER PATTIES (3.3 OZ.)	400	205	8-10 MIN.	13		
	MEAT LOAF	325	165	40-45 MIN.	4		
	STEAMSHIP ROUND (80 LBS. QUART.)	275	135	2-3/4 HRS. F	2		
	ROLLED BEEF ROAST (12-15 LBS.)	275	135	2-1/2 HRS.	4		
	STANDING RIB ROAST (20 LBS. RARE)	235	115	2-3/4 HRS.	2		
	SHELL STEAKS (100Z.)	450	230	7-8 MIN.	6		
	POT PIES	400	205	30-35 MIN.	6		
	STUFFED PEPPERS	350	175	15-20 MIN.	4		
	LASAGNA	260	125	90 MIN.	4		
	HOT DOGS	325	165	10-15 MIN.	6		
PORK	BAKED, STUFFED PORK CHOPS	375	190	25-30 MIN.	6		
	BACON	400	205	5-7 MIN.	13		
VEAL	BONED VEAL ROAST (15 LBS.)	300	150	3 HRS. 10 MIN.	3		
LAMB	LAMB CHOPS	400	205	7-8 MIN.	6		
POULTRY	CHICKEN BREASTS & THIGHS	350	175	40 MIN.	6		
	CHICKEN BACKS & WINGS	350	175	35 MIN.	6		
	CHICKEN, QUARTERED	350	175	30 MIN.	6		
	TURKEY ROLL (18 LB.)	310	155	3-3/4 HRS.	4		
	POT PIES	400	205	30-35 MIN.	6		
FISH	FISH STICKS	335	170	16-18 MIN.	13		
SEAFOOD	COD, HALIBUT (FROZEN)	350	175	20 MIN.	6		
	SHRIMP, BAKED STUFFED	400	205	6-7 MIN.	6		
	LOBSTER, BAKED STUFFED	400	205	10 MIN.	4		
	LOBSTER TAILS (FROZEN)	425	220	9 MIN.	6		
CHEESE	MACARONI & CHEESE CASSEROLE	350	175	30 MIN.	6		
	CHEESE SANDWICHES, GRILLED	400	205	8 MIN.	13		
POTATOES	POTATOES, BAKED (120 COUNT)	400	205	50 MIN.	6		
	POTATOES, SLICED OR DICED	325	165	10 MIN.	6		
	FRENCH FRIES (FROZEN)	TIMES & TEMPS WILL VARY AS TO CUT					
PIES	FROZEN BERRY PIES (36 - 22 OZ. EA.)	325	165	35 MIN.	6		
	FROZEN FRUIT PIES (24 - 46 OZ. EA.)	325	165	45-50 MIN.	6		
	FRESH APPLE PIE (36 - 20 OZ. EA.)	350	175	25-30 MIN.	6		
	PUMPKIN PIE	300	150	30-50 MIN.	6		
	FRUIT CRISP	300	150	25 MIN.	6		
	FRUIT COBBLER	300	150	30 MIN.	6		
	APPLE TURNOVERS	350	175	15 MIN.	6		
BREADS	BREAD (32 -1 LB. LOAVES)	325	165	30 MIN.	4		
	CORN BREAD (NORTHERN)	325	165	25 MIN.	6		
	CORN BREAD (SOUTHERN)	375	190	15-20 MIN.	6		
	HAMBURGER ROLLS	275	125	15 MIN.	6		
	YEAST ROLLS	300	140	25 MIN.	6		
	BISCUITS	400	205	6 MIN.	6		
	ROLLS, BROWN & SERVE	350	175	15 MIN.	6		
CAKES	SHEET CAKES (5 LBS. BATTER PER PAN)	325	165	16-18 MIN.	6		
COOKIES	CHOCOLATE CAKE	325	165	20 MIN.	6		
	BROWNIES	325	165	15 MIN.	6		
	DANISH PASTRY	325	165	12 MIN.	6		
	CINNAMON BUNS	325	165	20 MIN.	6		
	SUGAR COOKIES	275	125	15 MIN.	13		
	CREAM PUFFS	325	165	20-25 MIN.	6		
	CHOCOLATE CHIP COOKIES	325	165	10 MIN.	13		
	PEANUT BUTTER COOKIES	300	150	10 MIN.	13		

**NOTE: Your times and temperatures may vary from those shown on this chart. Your results depend on weight per pan, temperature of the product before loading, the recipe, type of pan, and calibration of the thermostat. If your recipes vary from these, write in your proven times and temperatures for your future use.**

## D. COOK & HOLD/ROAST & HOLD RECOMMENDED TIME & TEMPERATURE

PRODUCT	QTY	COOK TEMP	HOLD TEMP	COOK TIME	HOLD TIME MINIMUM	TOTAL TIME
PRIME RIB BONE IN CAP OFF 14 – 18 LBS (6.4 – 8.1 KG)	1 3 6	200°F 93°C	140°F 60°C	3 HRS 3-1/4 HRS 3-1/2 HRS	1 HR 1-1/2 HRS 2 HRS	4 HR 4-3/4 HRS 5-1/2 HRS
PRIME RIB BONE IN CAP ON 18 – 22 LBS (8.1 – 10 KG)	1 3 6	200°F 93°C	140°F 60°C	3-1/2 HRS 4 HRS 4-1/2 HRS	1 HR 1-1/2 HRS 2 HRS	4-1/2 HRS 5-1/2 HRS 6-1/2 HRS
TOP OR BOTTOM ROUNDS 10 – 12 LBS (4.5 – 5.4 KG)	1 3 6	200°F 93°C	140°F 60°C	3-1/2 HRS 4 HRS 4-1/2 HRS	1 HR 1-1/2 HRS 2 HRS	4-1/2 HRS 5-1/2 HRS 6-1/2 HRS
PORK ROAST OR HAM CAP OFF 10 – 12 LBS (4.5 – 5.4 KG)	1 3 6	250°F 121°C	170°F 76°C	4 HRS 4-1/4 HRS 4-1/2 HRS	1 HR 1-1/2 HRS 2 HRS	5 HR 5-3/4 HRS 6-1/2 HRS
TURKEY 20 - 22 LBS (6.4 – 8.1 KG)	1 2	250°F 121°C	170°F 76°C	3-3/4 HRS 4 HRS	1 HR 1-1/2 HRS	4-3/4 HR 5-1/2 HRS
LEG OF LAMB BONE IN 8 - 10 LBS	2 4 6	225°F 107°C	160°F 71°C	2-1/2 HRS 2-3/4 HRS 3 HRS	1 HR 1-1/2 HRS 2 HRS	3-1/2 HR 4-1/4 HRS 5 HRS

### COOK & HOLD - ROAST & HOLD

Control Options with COOK & HOLD - ROAST & HOLD feature include conveniences not found in standard control ovens. This feature is particularly valuable when roasting meats. By using the slower speed "Roast - Lo Fan" for the primary cooking cycle and setting a lower temperature (140°F or higher is recommended) for the hold cycle, your meats can be cooked and then held for up to 16 hours. The lower temperatures used and the slower fan speeds reduce shrinkage, thus increasing yields. Also, meats roasted in this manner over longer periods tend to be more tender and juicy.

An added benefit of using your 5/9 to Roast & Hold is lower energy costs.

COOK & HOLD - ROAST & HOLD cooking is a three step process.

- **COOK or ROAST** - This step is controlled by the count down timer and the temperature controller. Meat is roasted at a lower temperature for a longer period of time. Meats are generally cooked until about 2/3 done in this cycle. At the end of the roasting cycle, the controls automatically shift to the "HOLD" mode.
- **STORED HEAT COOKING** - This is a natural change in temperature and is not a controlled function; i.e., there are no times or temperatures to set. It is a portion of the "HOLD" cycle as far as timing. In this step the oven temperature slowly drops down to the "HOLD" temperature setting.

This step may take 1 -2 hours. It is important that meats being cooked by this method be left in the "HOLD" cycle for at least two hours as they continue to cook.

- **HOLD** - Once the meat reaches the holding temperature, it can be held up to sixteen hours prior to serving. The blower at low speed will cycle on and off to maintain the "HOLD" temperature you set into the temperature controller.

**NOTE: The "COOK - HI-FAN" cycle can be substituted for the "ROAST-LO-FAN" cycle with the only change being the velocity of the fan being higher.**

### E. General Guidelines for Cook & Hold - Roast & Hold

- Always allow the meat to remain in the "HOLD" cycle for a minimum of two hours. This will assure that the stored heat of the "COOK - ROAST" cycle has brought it to the desired degree of doneness.
- Always thaw meats in a refrigerator and temper the meat 30-45 minutes at room temperature before cooking. Cooking frozen food products is not recommended, as it will increase the "COOK - ROAST" cycle and increase shrinkage.
- Aged meat cooks more rapidly and this should be taken into consideration when establishing cooking times.

---

## MAINTENANCE INSTRUCTIONS

These maintenance instructions are for the use of qualified service personnel only. Service by other than qualified personnel may result in damage to the oven and/or injury to the operator.

Qualified service personnel are those individuals, firms, companies or corporations which either in person or through an agent are engaged in and responsible for repair or servicing of commercial food preparation equipment, who are experienced in such work, familiar with all precautions required, and have complied with all requirements of state and local authorities having jurisdiction.

If you should require assistance in the selection of a qualified service agency, please contact Duke Manufacturing Co.'s Service Department at 800-735-3853.

### A. Adjustments

Quite often malfunctions, which are attributed to defects, may be repaired by adjusting certain parts rather than replacing them.

### B. Door Adjustment

All 6/13 Series Convection Ovens (except model option Q) have doors that are inter-connected so they operate simultaneously by means of a chain and turnbuckle assembly. The doors are properly adjusted and inspected before the oven leaves the factory. However, from time to time it may become necessary to readjust the doors after usage. If you find it necessary to adjust the doors for proper operation, the chain and turnbuckle assembly is located behind the panel that is over the doors. It is best to adjust turnbuckles while the door is in an unlatched position.

- Loosen the jam nut on both turnbuckles.
- Make adjustments simultaneously to both turnbuckles.
- Loosening or tightening the assembly will not allow the doors to work properly. Ideally, you should loosen one turnbuckle and tighten the other. Some experimentation will indicate which direction you will want to make your adjustments.
- Once the doors are operating properly, retighten the jam nuts so the unit will stay in adjustment. Test the door to make certain it is in adjustment.
- Replace cover.

### C. Door Switch Adjustment

You may also wish to adjust the door switch. The door switch is located behind the combustion compartment cover, on the right side. The door switch is activated by a cam, which is mounted to the door's hinge pin with a setscrew.

- Open the doors fully.
- Remove the lower cover by loosening the four screws located inside the door opening.
- Position the doors so they are nearly closed but not latched.
- To adjust the cam loosen the setscrew and rotate the cam until you hear the switch click.
- Tighten the setscrew in the cam. Test the door to make certain the switch will make contact with the doors closed.
- Replace the cover.

**CAUTION: The door turnbuckles and door switch are located in a heated zone. Care should be taken to avoid burns.**

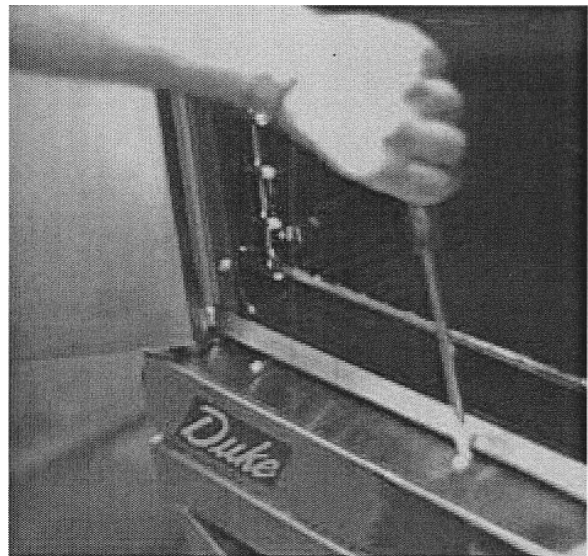

**Door Switch Access Panel**

### D. Thermostat Calibration

Electro-Mechanical Controls Only (“Q” & “V”). Not applicable to Ovens with Solid State Controls.

In many convection ovens thermostats have been the cause of more operating problems than any other component part. Thermostats, being mechanical devices, do sometimes fail, in which case only replacing the part will correct the problem. However, the great majority of thermostat related problems could be attributed to their being out of adjustment (calibration). A thermostat that is out of calibration may cause unsatisfactory cooking results such as uneven baking, prolonged cooking times, etc. If you are experiencing uneven cooking, it may be a result of excessive cooking temperatures. Refer to the cooking chart provided in Operating Instructions Section C.

### To Check Calibration:

- Turn the oven on by turning the Power Switch to the ON position.
- Open the doors and place a thermocouple in the center of the middle oven rack. A reliable mercury-type thermometer can be substituted if a pyrometer is not available.
- Turn the thermostat dial to 350°F (177°C). Allow the oven to preheat 1/2 hour.
- When the indicator light goes out, the thermostat has been satisfied. Check the pyrometer or thermometer to determine the internal oven temperature.
- If the reading on the pyrometer (or thermometer) is less than 10°F different from the setting of the thermostat, no adjustment is needed. If this reading is more than 10°F, proceed with calibration procedure.

### To Calibrate the Ovens

- Remove the thermostat knob by loosening the setscrew and pull the knob forward. Take care not to rotate the thermostat stem, which will change the setting.
- With a very small screwdriver, turn the screw located in the bottom of the hollow of the stem clockwise to lower the temperature or counterclockwise to raise the temperature. DO NOT allow the stem of the thermostat to rotate as you turn the screw.
- Open the door and turn the POWER SWITCH to the COOL DOWN position. This will allow the oven fan to come on without the burners and cool off the oven. Allow the oven to cool to about 250°F (120°C).
- Return the **POWER SWITCH** to the **ON** position and repeat the previous steps until the oven thermostat and the pyrometer (thermometer) reading agree.
- Replace the knob and tighten the setscrews.

**CAUTION: Maximum turn of screw "A" is 1-1/2 turns - clockwise or counter-clockwise.**

This thermostat is a direct-acting (opens on temperature rise) device.

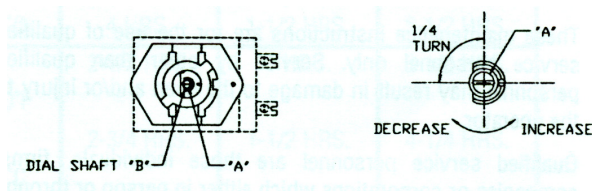

### E. Cleaning of the Ovens

The stainless steel on your oven can be kept clean with a good stainless steel cleaner, many of which are on the market. The painted surfaces should be wiped clean regularly with a MILD detergent. Moisten a cloth and wipe down the oven while it is COLD. Wiping down an oven while it is hot will cause streaking and otherwise unsatisfactory results. Once the oven is clean it can be wiped down with light oil.

Porcelain oven interiors should be cleaned regularly using a degreasing agent. For heavier deposits a commercial oven cleaner such as Dow Oven Cleaner, Easy-Off, or Mr. Muscle can be used. Care must be taken to prevent these alkaline-type cleaners from coming in contact with any aluminized steel surfaces in the oven, including the blower wheel.

The blower wheel, racks and rack supports can be removed and soaked in a solution of ammonia and water.

Make certain that all parts are thoroughly rinsed before returning to use.

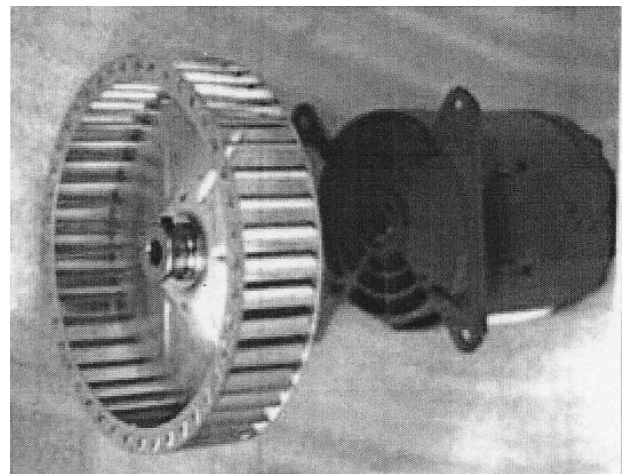

**Blower Wheel**

## 5/9 – Electric Convection Oven Repair Parts List

<b>Part #</b>	<b>Description</b>	<b>Part #</b>	<b>Description</b>
155195	Baffle, stainless steel	154532	Probe, "X","XX","Z","ZX" models
155197	Baffle, Porcelain	154379	Probe, temp, "ZZ" only
153233	Bracket, stacking (for double sections)	155113	Rack, support, oven, 9-position
154075	Buzzer, 208/240v	155114	Rack, oven 5/9
153156	Contact, 3-pole, 50 amp, 208/240v	153498	Relay, fan, 120V, "X" model
153157	Contact, 3-pole, 30 amp, 208/240v	153776	Relay, fan, 208-240v, "X" model
153159	Contact, 2-pole, 60 amp, 208/240v	153144	Switch, 2-speed fan (opt.)
153499	Control, "X" ** See NOTE	155107	Switch, actuator, door
153564	Control, "XX"	512289	Switch, power, "ZZ" model
153150	Control, "Z"	153460	Switch, rotary
153481	Control, "ZX"	149403	Thermostat, (Q & V models)
155378	Control, "ZZ"	512971	Timer, 60 minute, 220V, 60Hz
153416	Catch, Door	512972	Timer, 60 minute, 230V, 50Hz
155451*	Door, assembly, w/glass hinged right	153358	Transformer, 240/480V, 1KVA
155454	Door, assembly, w/glass hinged left	154452	Transformer, "ZZ"
155407	Door, assembly, solid	600100	Kit, Flue Guard (Optional)
153056	Door Bearing	155125	Bracket, Stacking
155132	Door glass		
148077	Door micro switch		
155076	Element, outer, 208V, 8.0KW		
155077	Element, inner, 240V, 8.0KW		
155078	Element, center, 240V, 8.0KW		
155079	Element, outer, 240V, 8.0KW		
155080	Element, inner, 208V, 5.5KW		
155081	Element, center, 208V, 5.5KW		
155082	Element, outer, 208V, 5.5KW	600139	Kit, Repl. 59EXX, C.P. 2SP
155083	Element, inner, 240V, 5.5KW	600140	Kit, Repl. 59EXX, C.P. 1SP
155084	Element, center, 240V, 5.5KW		
155085	Element, outer, 240V, 5.5KW		
155085	Element, outer, 208V, 8.0KW		
155074	Element, inner, 208V, 8.0KW		
155075	Element, center, 208V, 8.0KW		
153093	Fan Wheel		
153201	Fuse, 10 amp		
153200	Fuse holder		
155006	Gasket, door – bottom		
155007	Gasket, door – top		
155008	Gasket, door – side		
153115	Grommet, silicone, temp. bulb/probe		
155404	Handle, door assembly		
153142	Knob, "V","X","XX","Z","ZX" models		
153143	Knob, digital control, "Z","ZX" models		
153766	Knob, "X", digital		
153801	Latch, roller assembly		
153036	Motor, ½ HP, 2-speed, 208/240v		
153204	Light, oven ready, 208/240v		
155313	Mylar panel, cook/timer "V" only		
155314	Mylar, digital, COMM 6000"X" only		
155253	Mylar, "XX" control		
155449	Mylar, "ZX" only		
155450	Mylar, control panel, 5/9 "Z" only		
154377	PCB assembly, 3-relay, "ZZ" only		

NOTE: 153499 Control "X" is no longer available. One of the following replacement control kits must be ordered.

600139	Kit, Repl. 59EXX, C.P. 2SP
600140	Kit, Repl. 59EXX, C.P. 1SP

5/9 DOOR ASSEMBLY (TYPICAL)  
LEFT HAND HINGED SHOWN

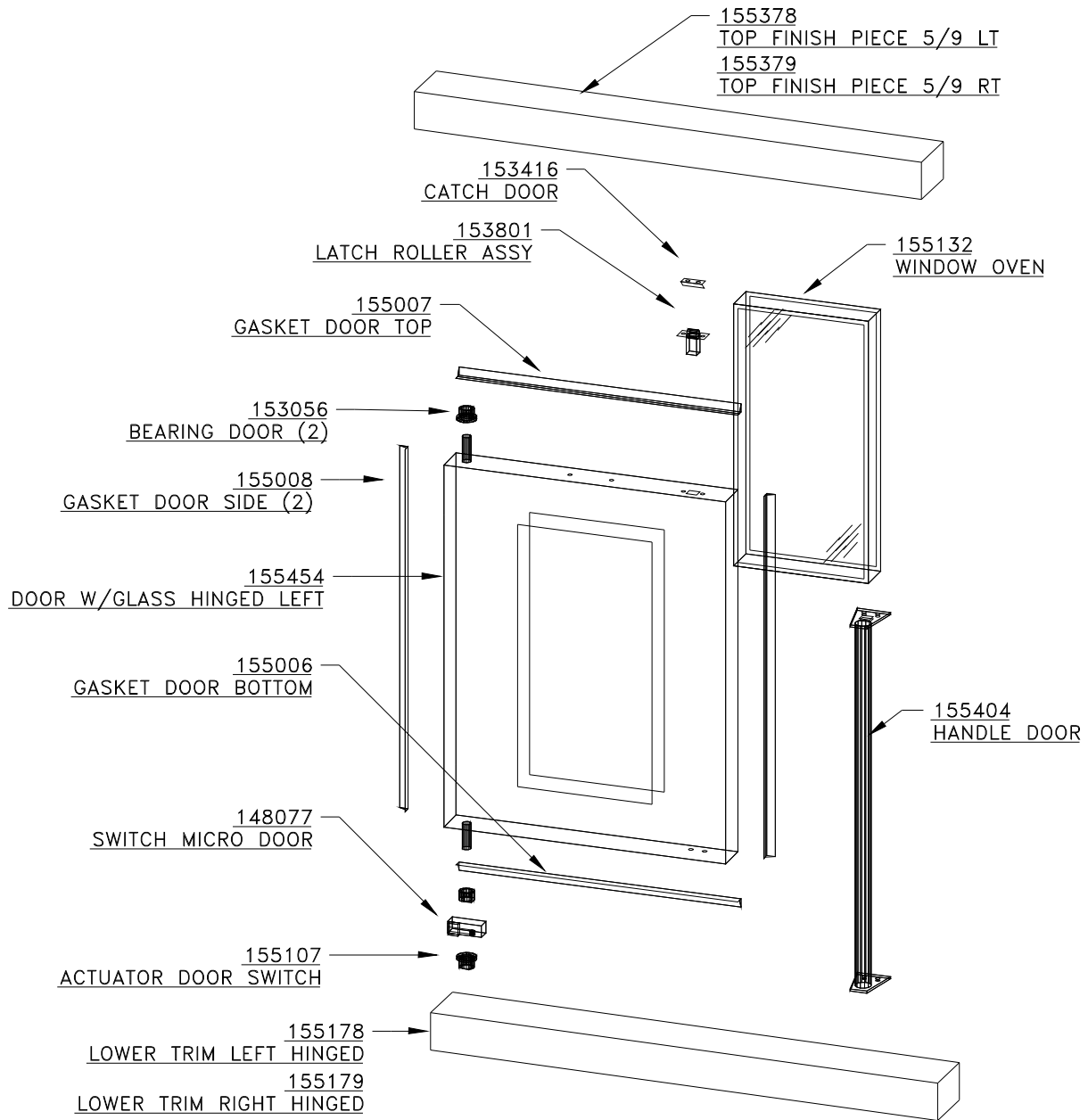

# MODEL 59-V OVEN CONTROLS

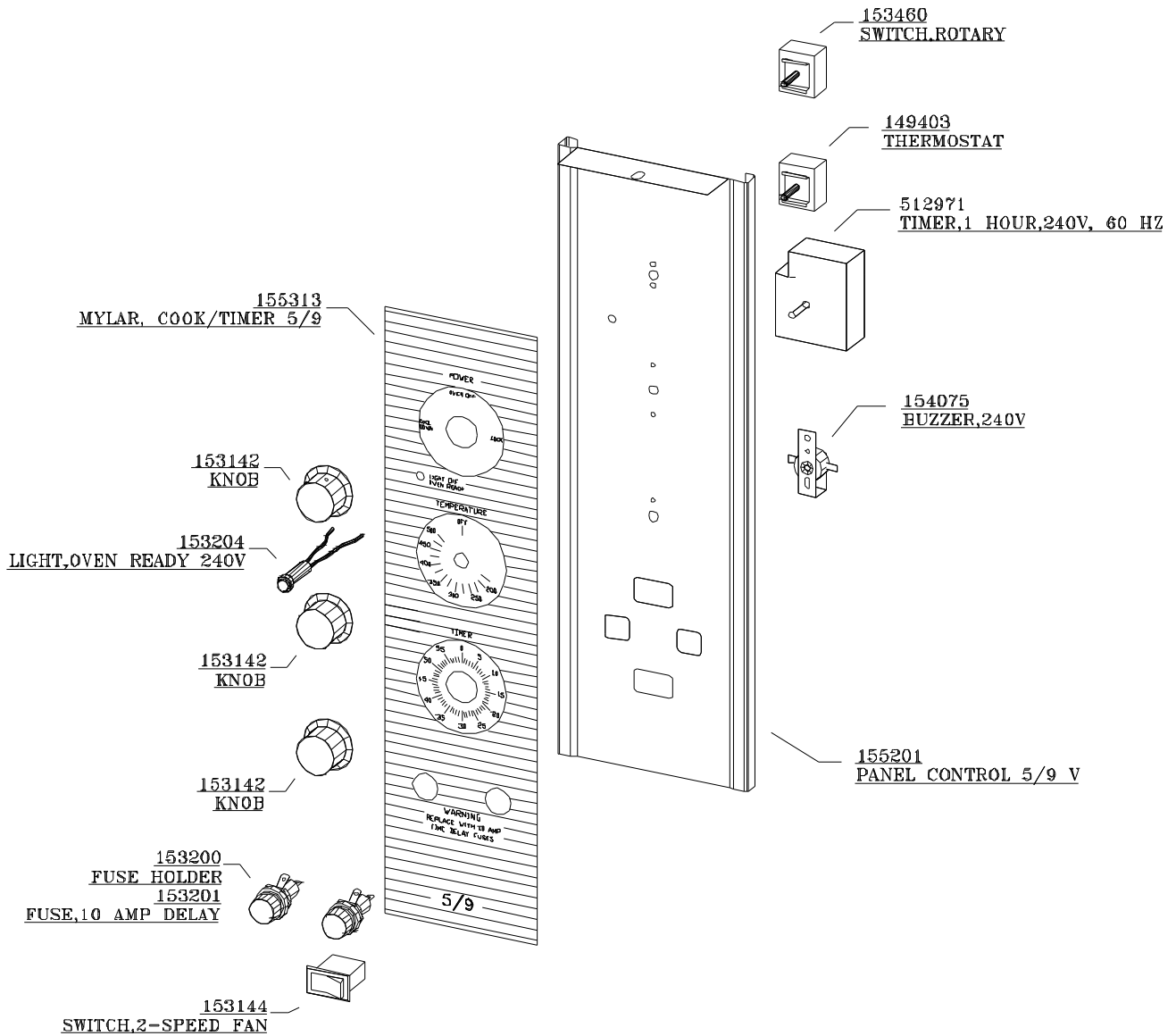

# MODEL 59-X OVEN CONTROLS

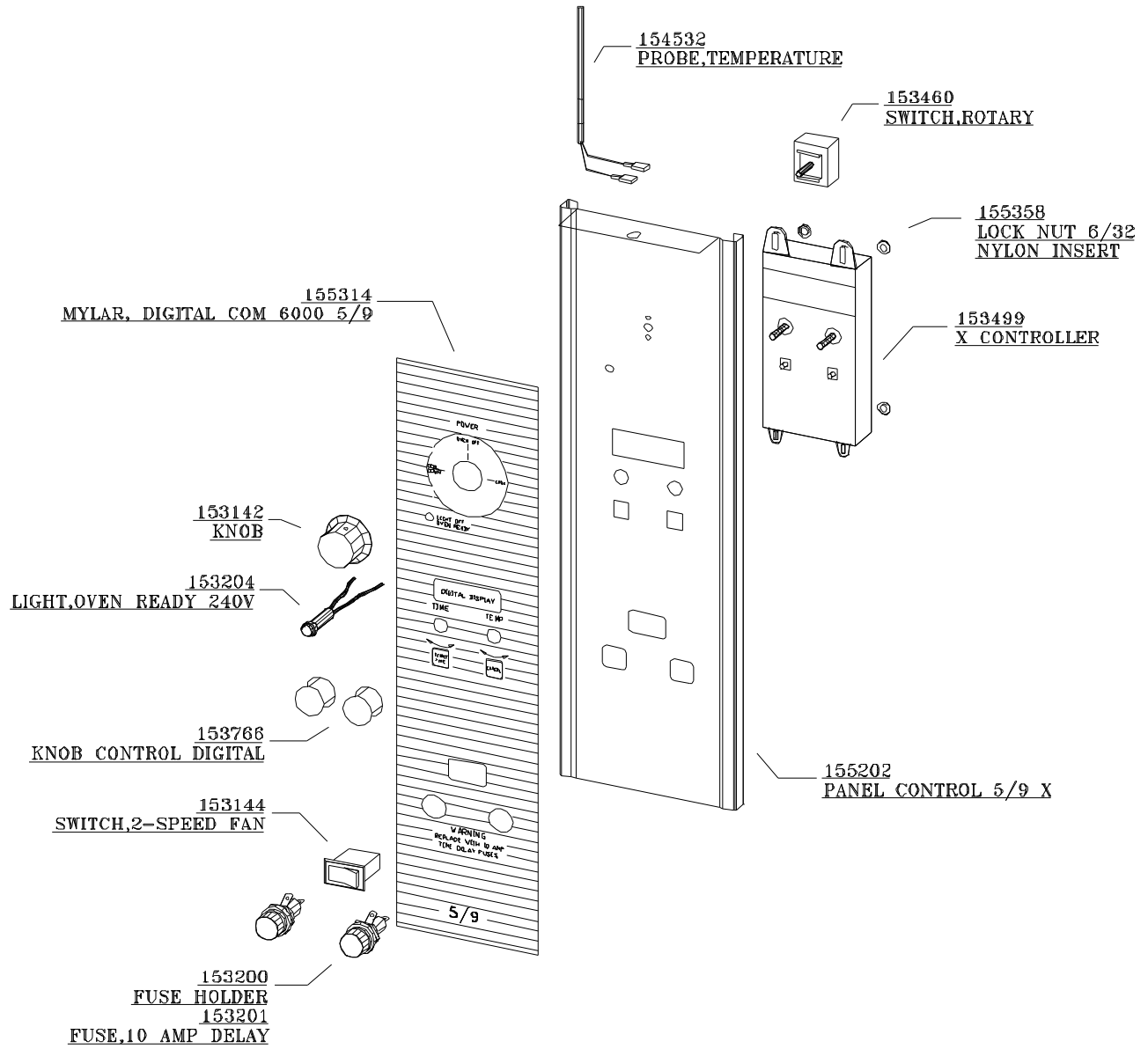

MODEL 59-Z OVEN CONTROLS

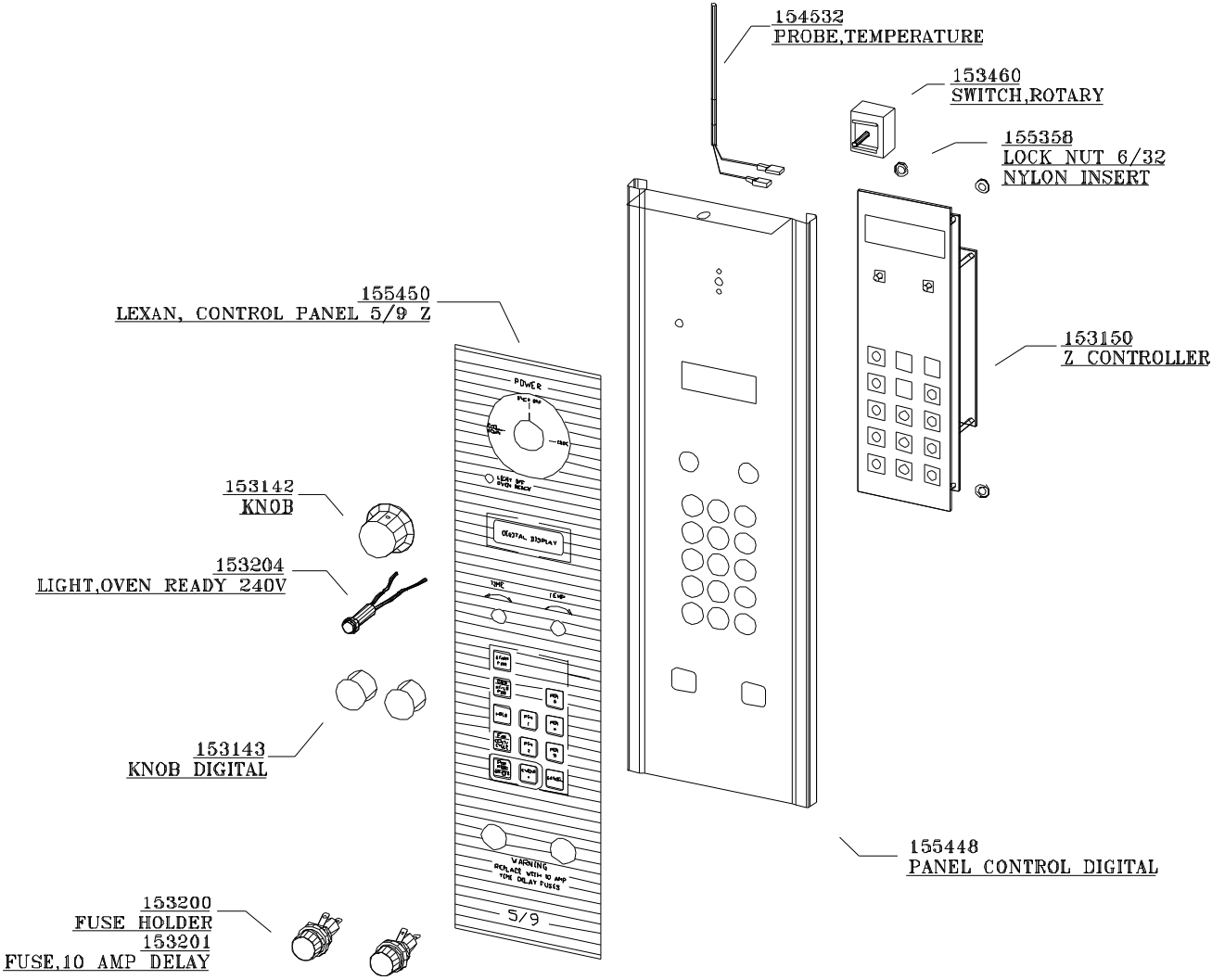

MODEL 59-XX OVEN CONTROLS

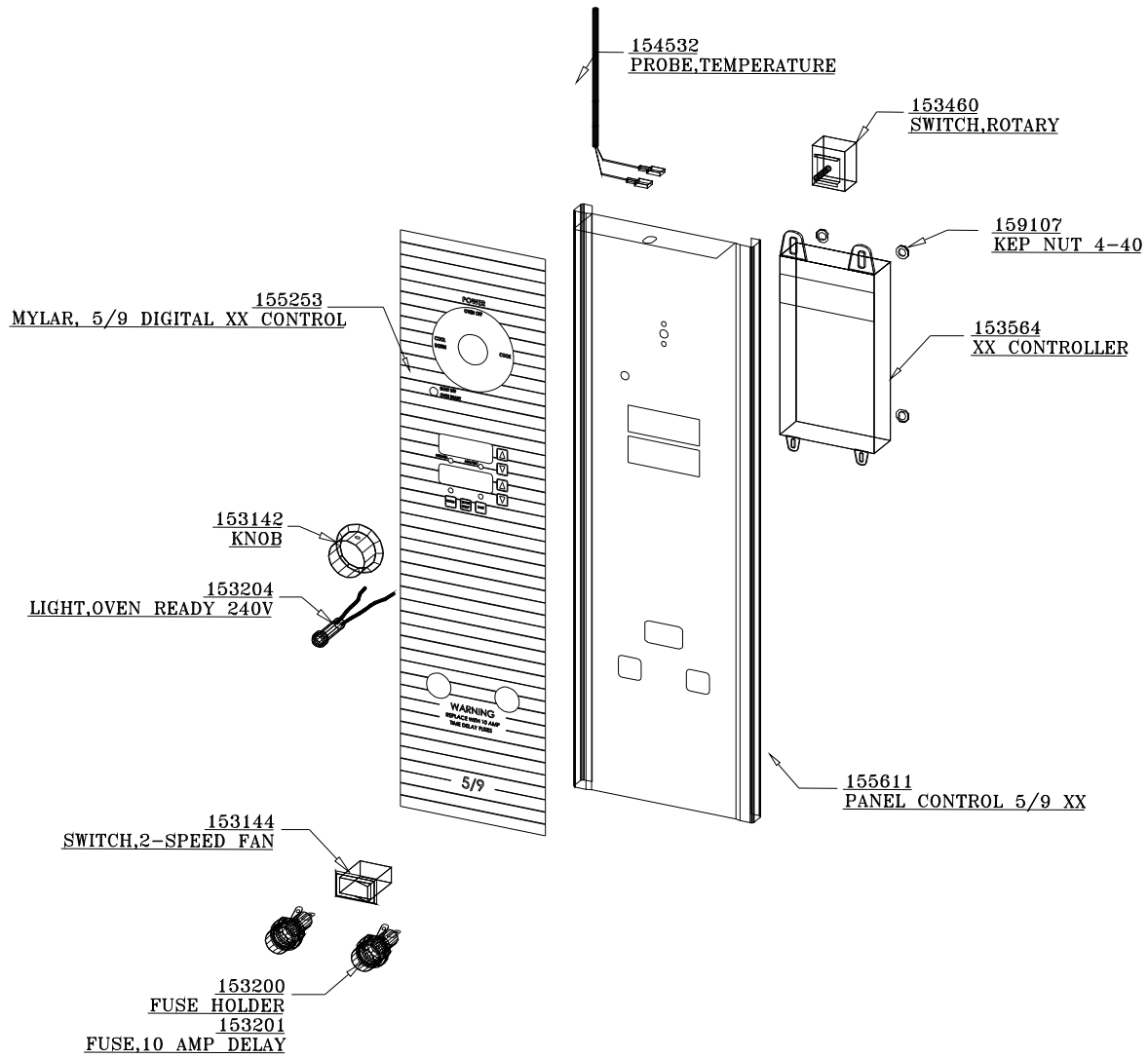

# MODEL 59-ZX OVEN CONTROLS

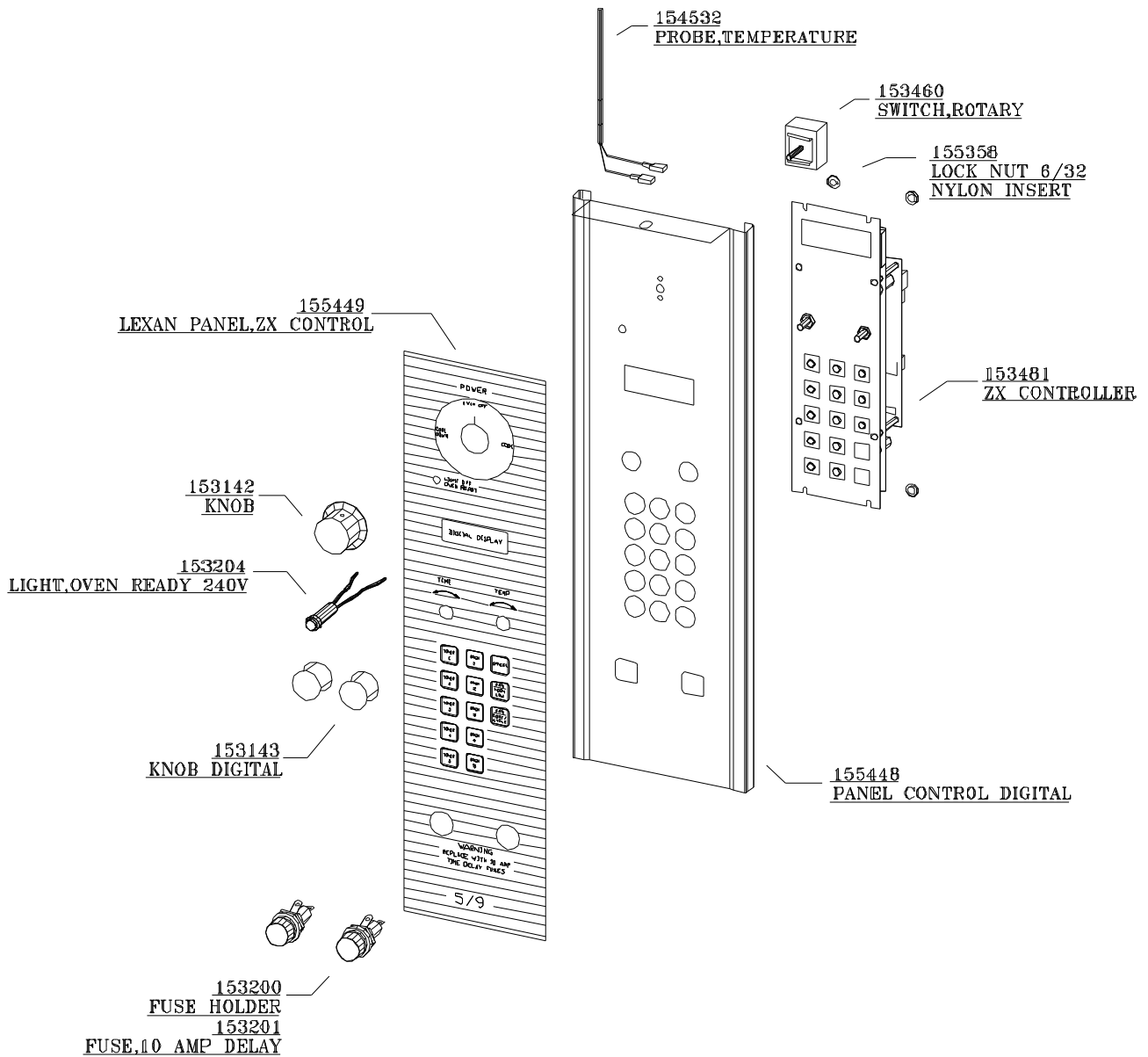

# MODEL 59-ZZ OVEN CONTROLS

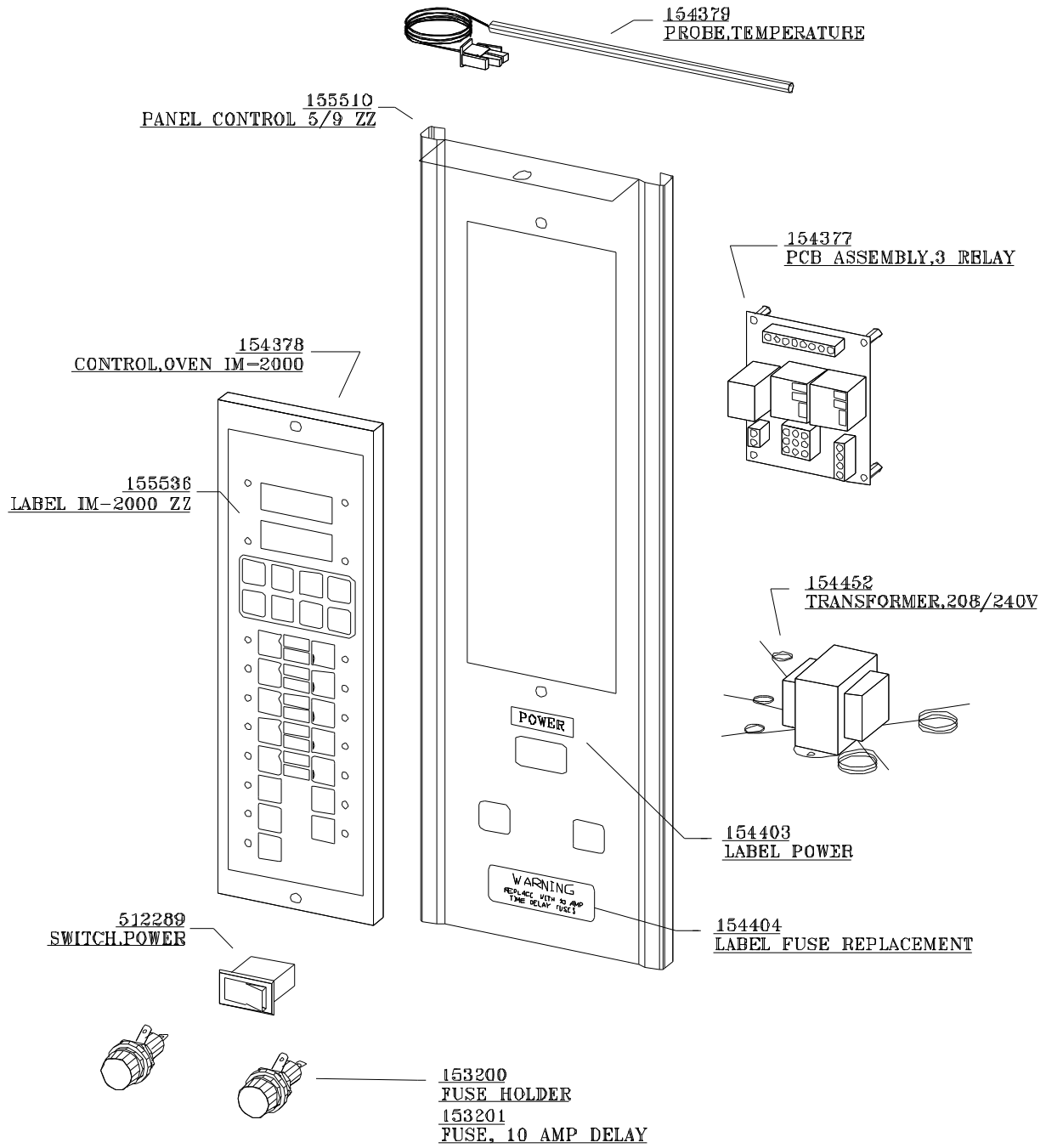

# Contactor Identification

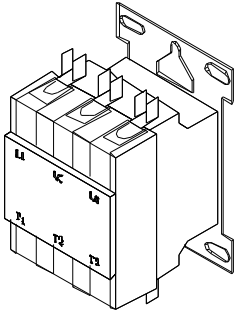

153156  
CONTACTOR, 50AMP

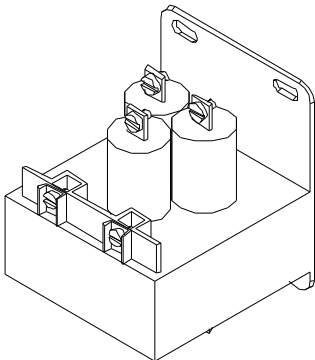

153157  
CONTACTOR, 30AMP

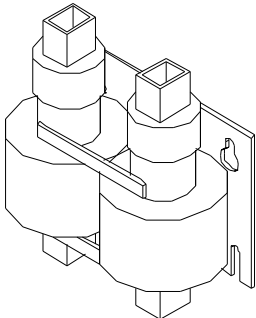

153159  
CONTACTOR, 60AMP

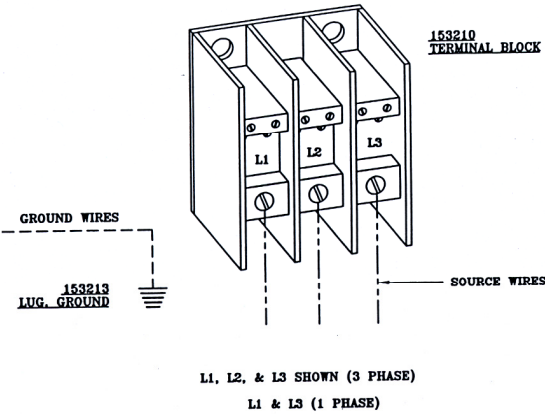

## FLUE GUARD

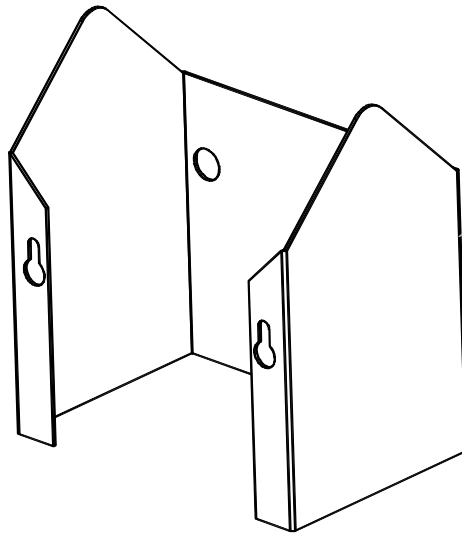

---

## Securing Double Stacked Ovens

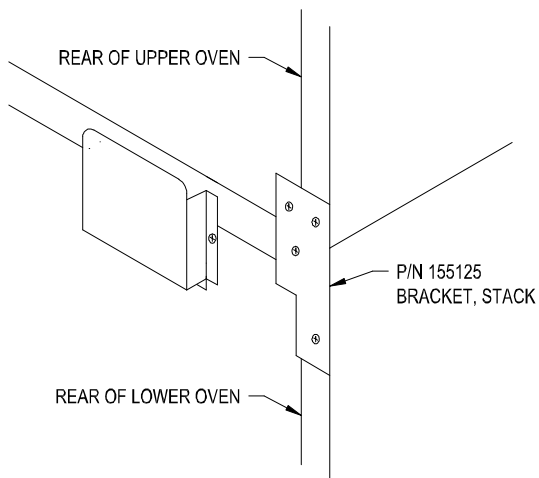

- 1.) On rear of top oven remove two existing screws that are located at the lower right hand corner.
- 2.) On rear of bottom oven remove two existing screws that are located at the upper right hand corner.
- 3.) Install stacking bracket using the existing screws as shown in figure.
- 4.) Repeat steps to install 2<sup>nd</sup> stacking bracket on left hand side.

SECURING 5/9  
DOUBLE STACKED OVENS

# 5/9 "V" CONTROLLER

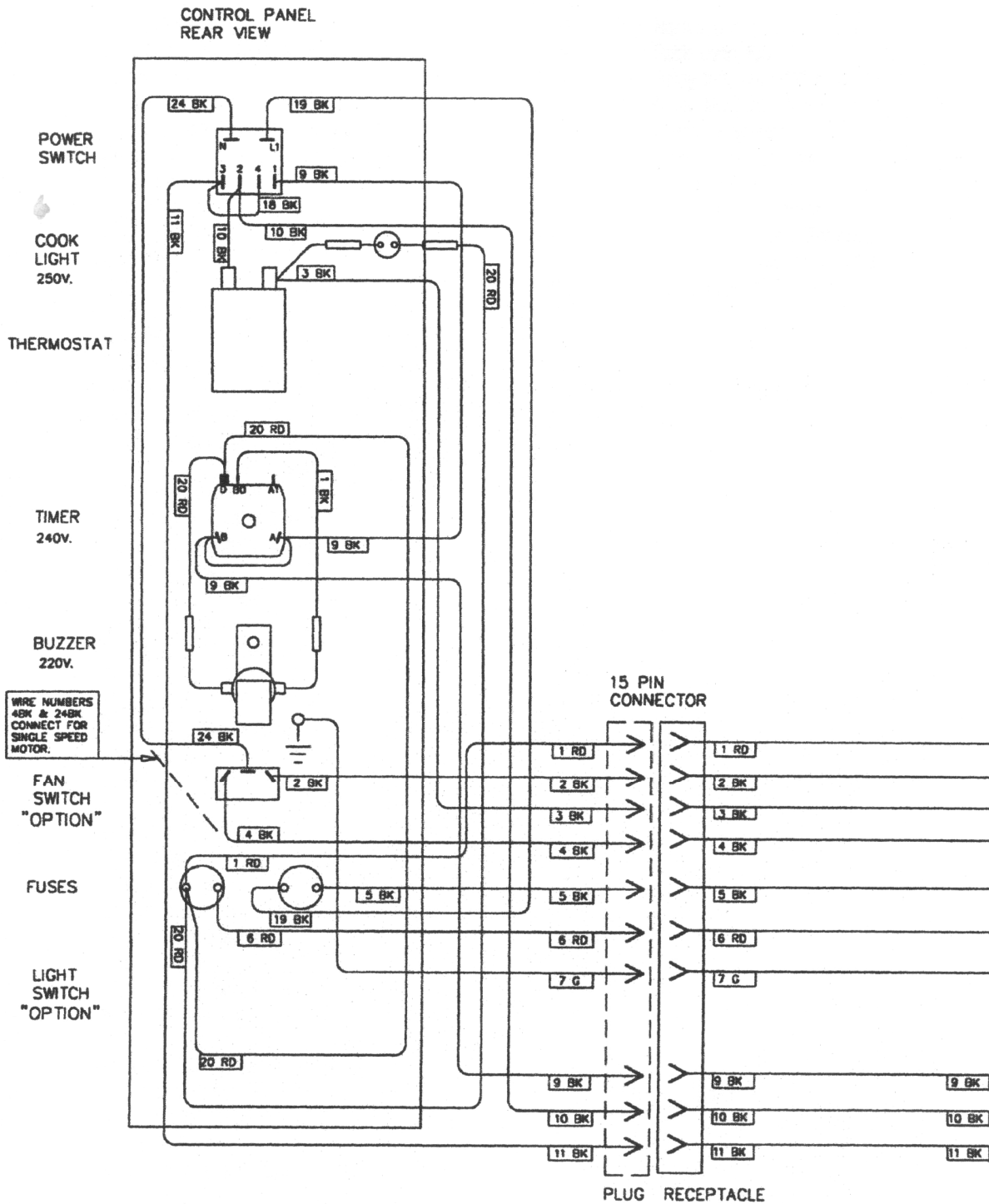

# 5/9 "V" 208/240V MOTOR/ELEMENT SIDE

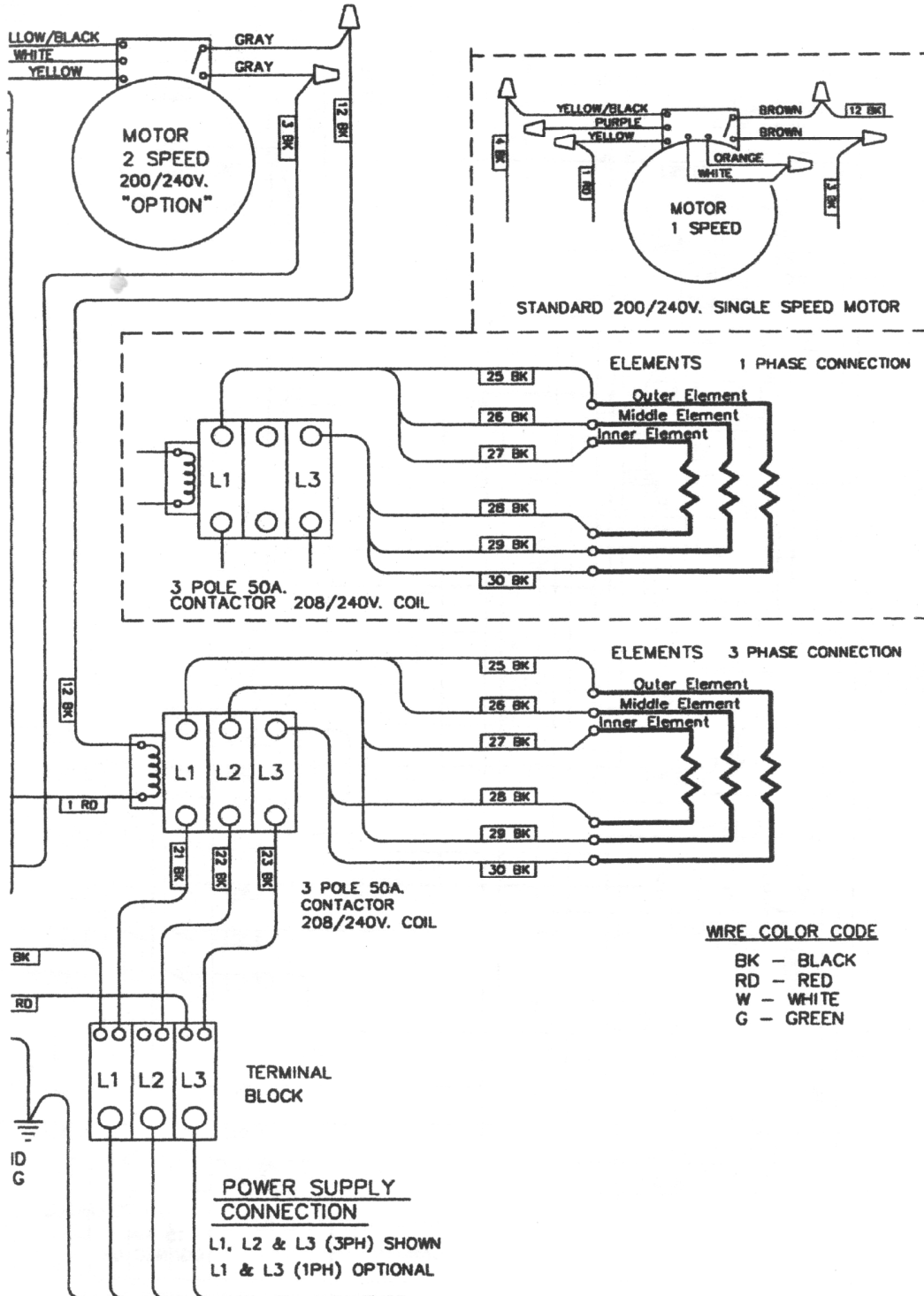

# 5/9 "X" CONTROLLER

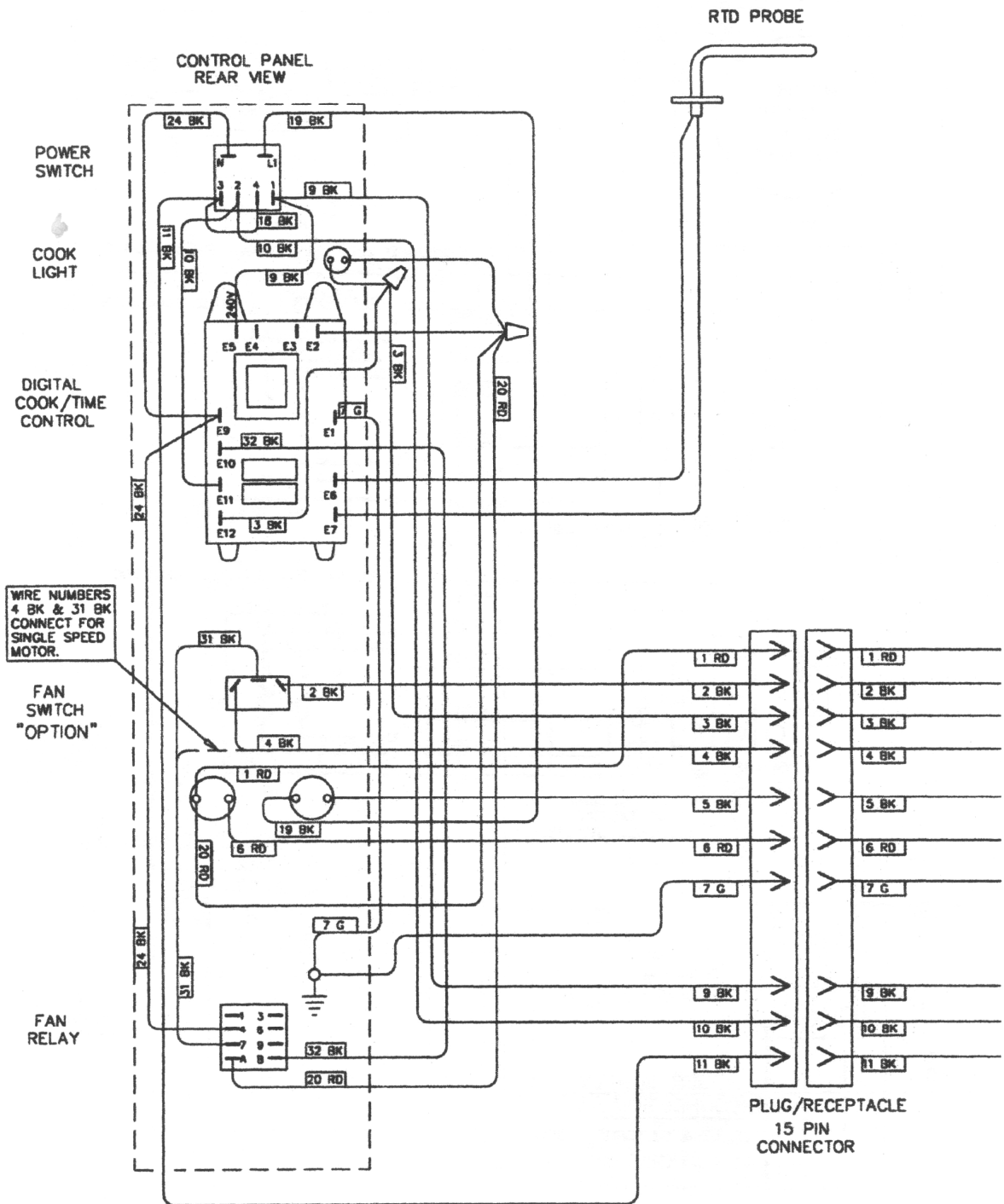

# 5/9 "X" 208/240V MOTOR/ELEMENT SIDE

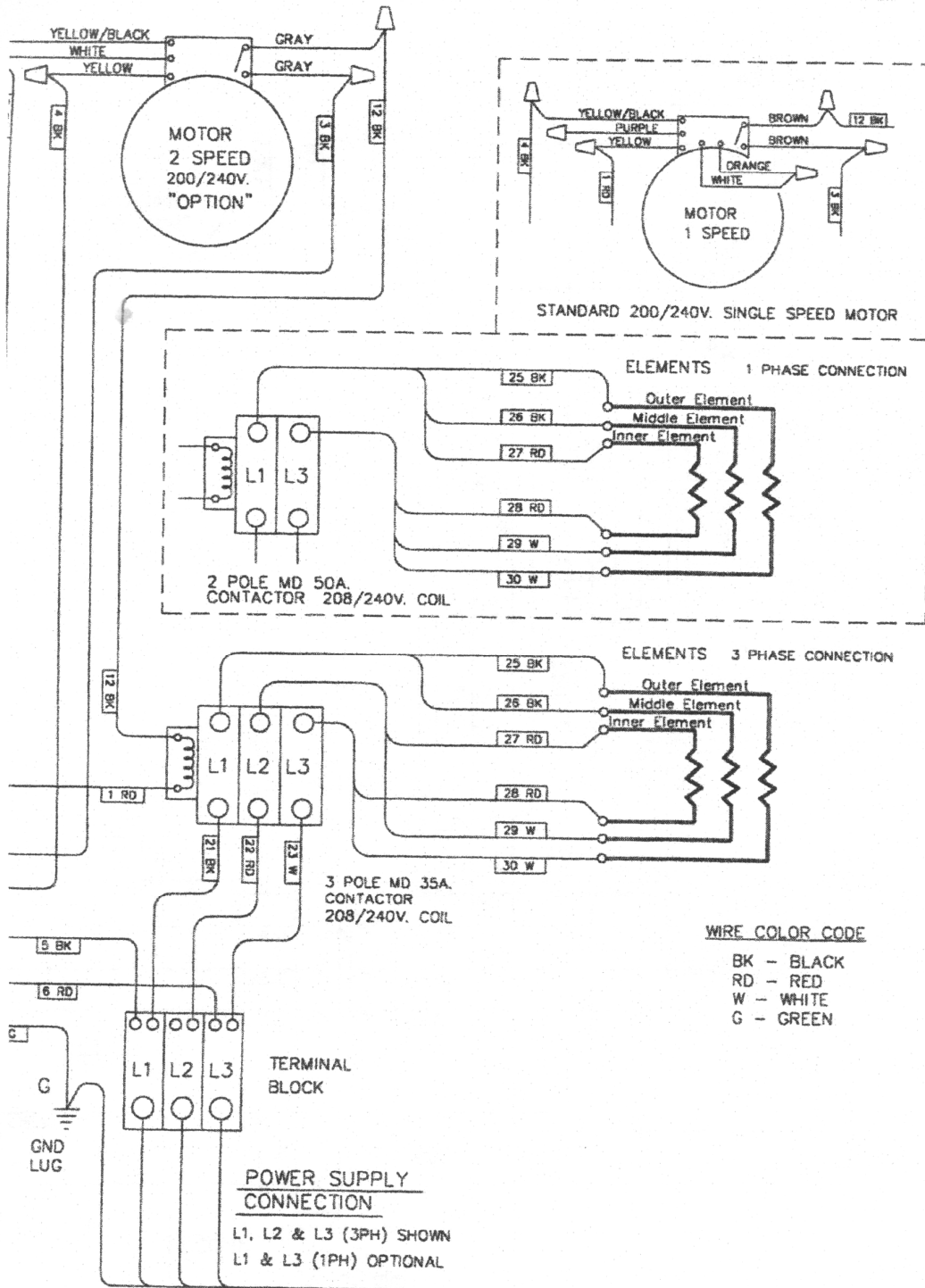

# 5/9 "Z" & "ZX" CONTROLLER

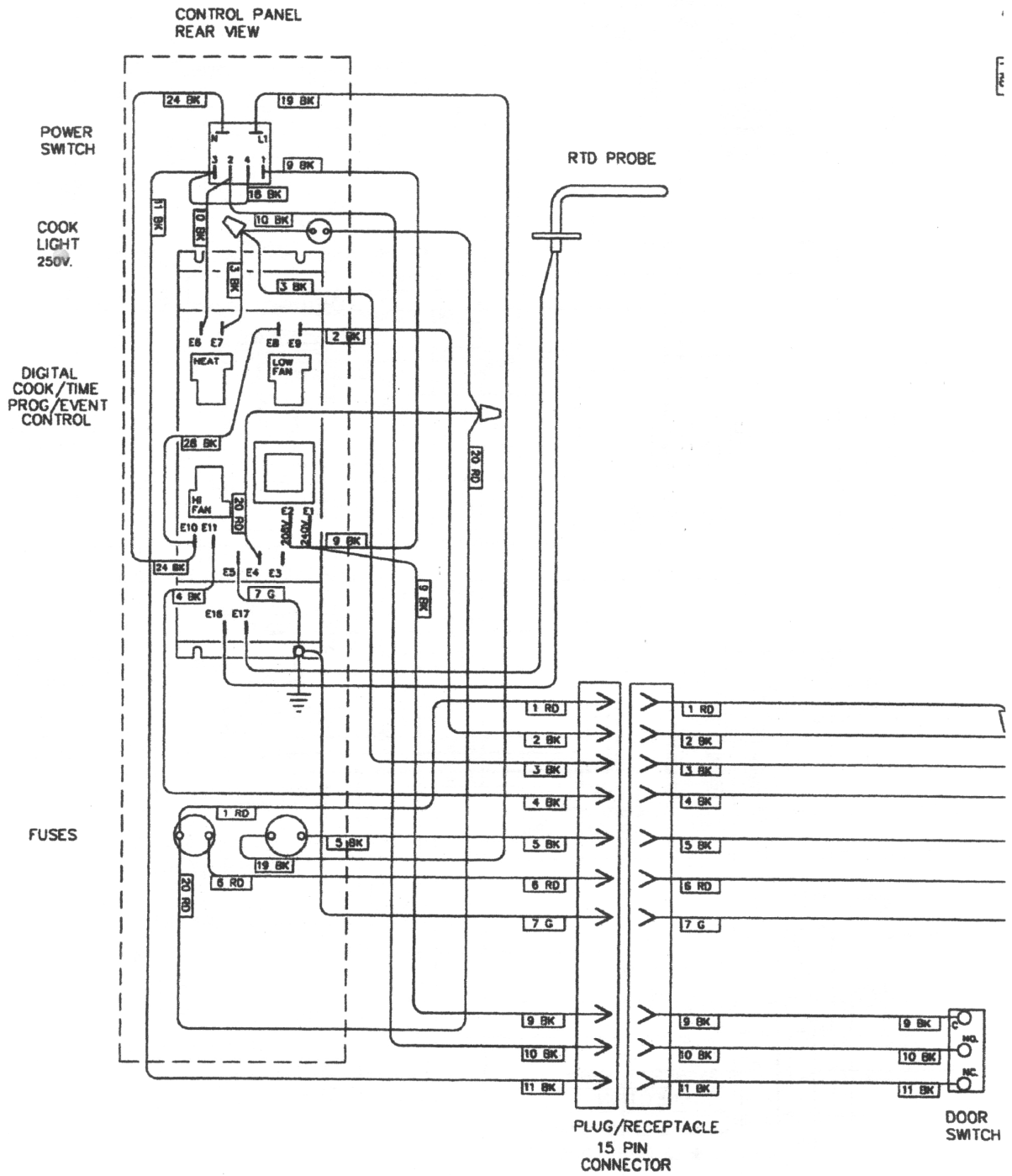

# 5/9 "Z" & "ZX" 208/240V MOTOR/ELEMENT SIDE

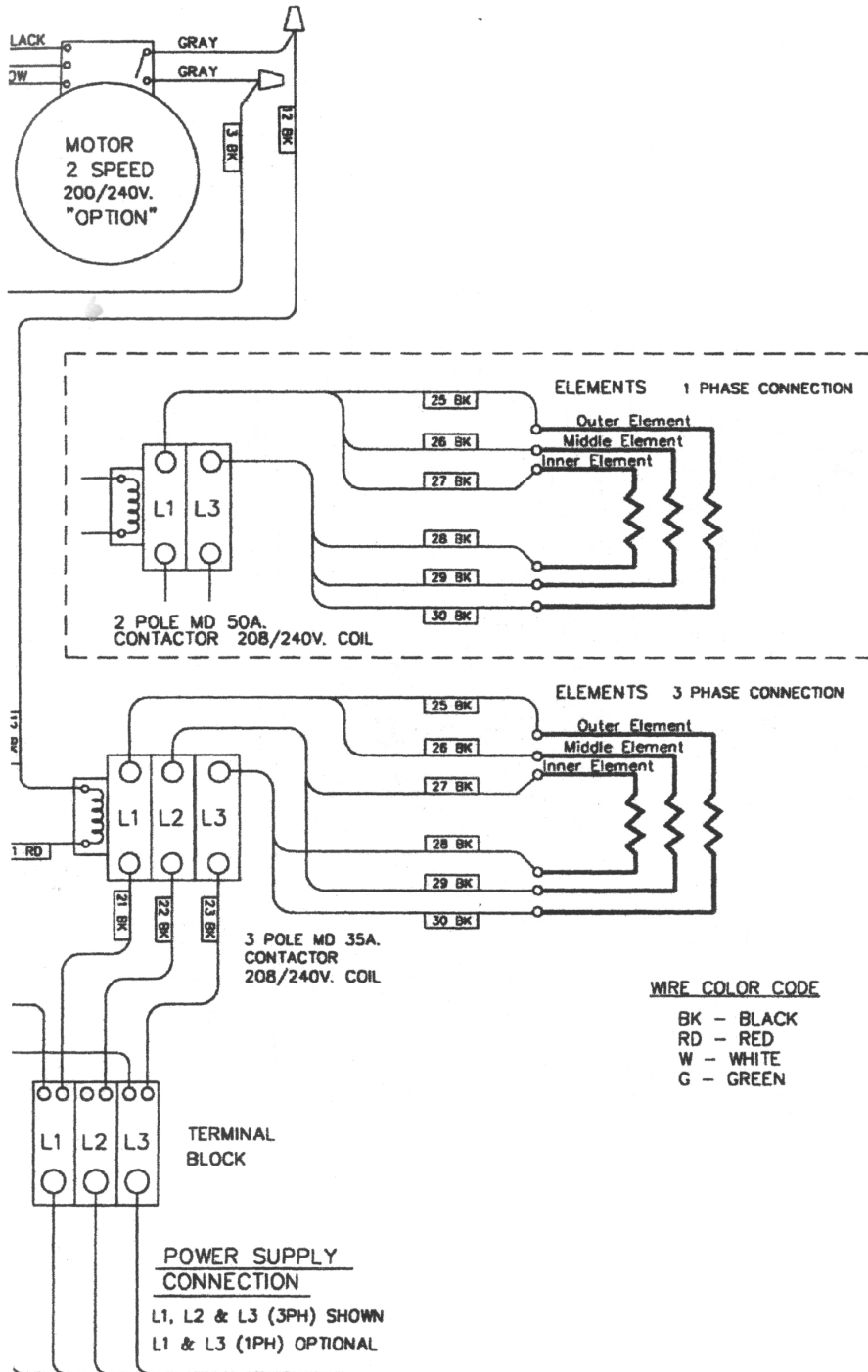

# 5/9 "ZZ" CONTROLLER

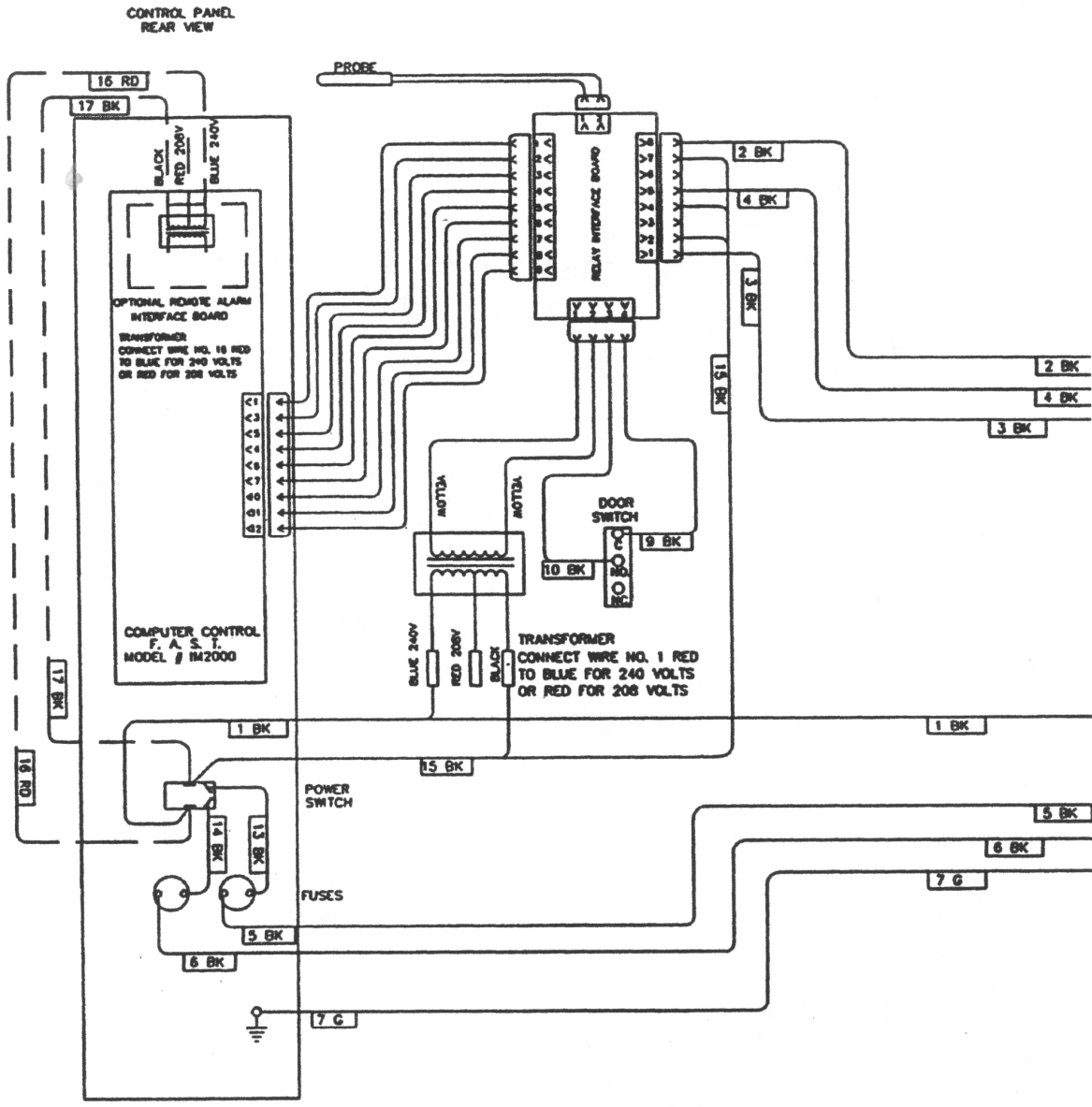

# 5/9 "ZZ" 208/240V MOTOR/ELEMENT SIDE

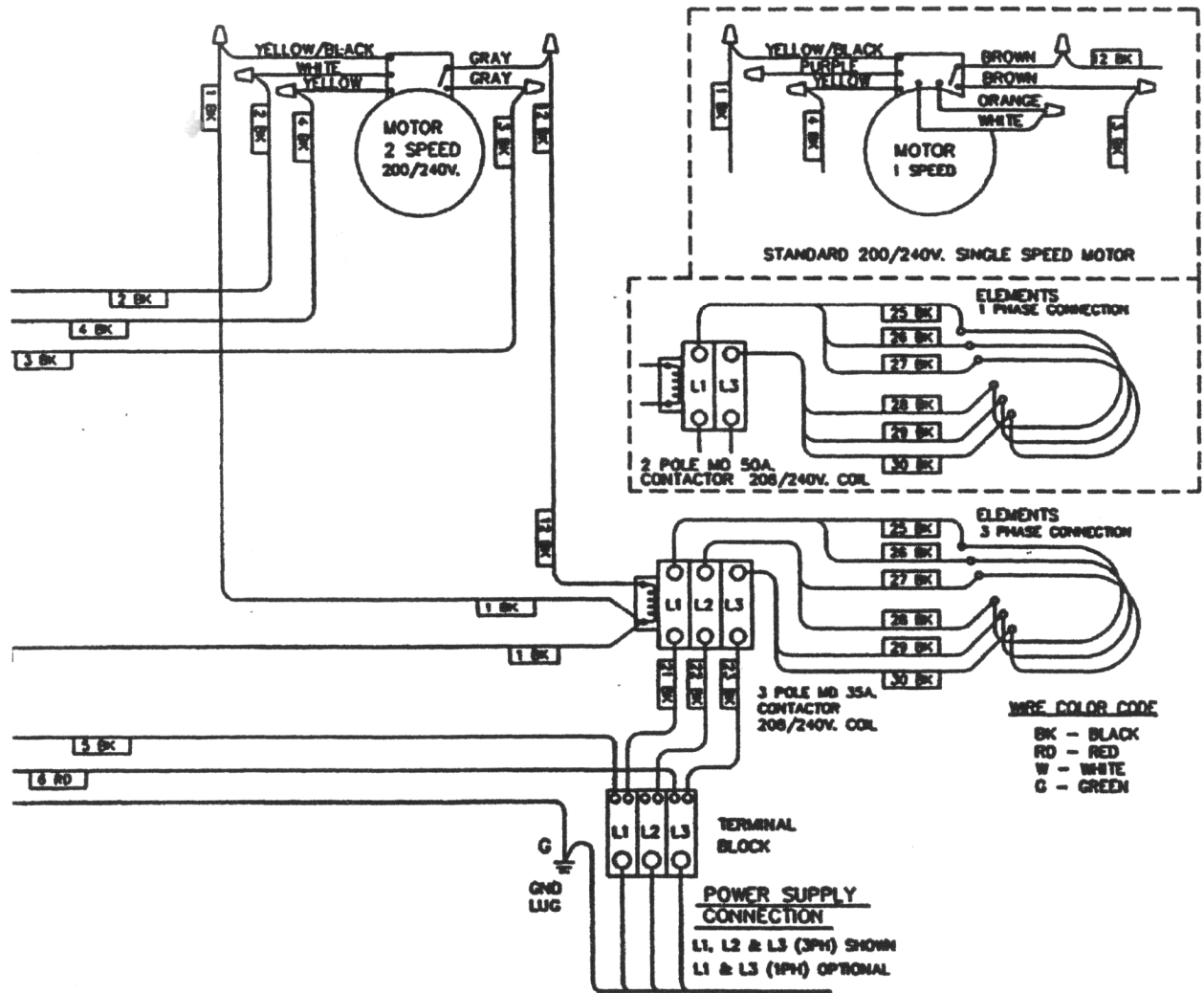

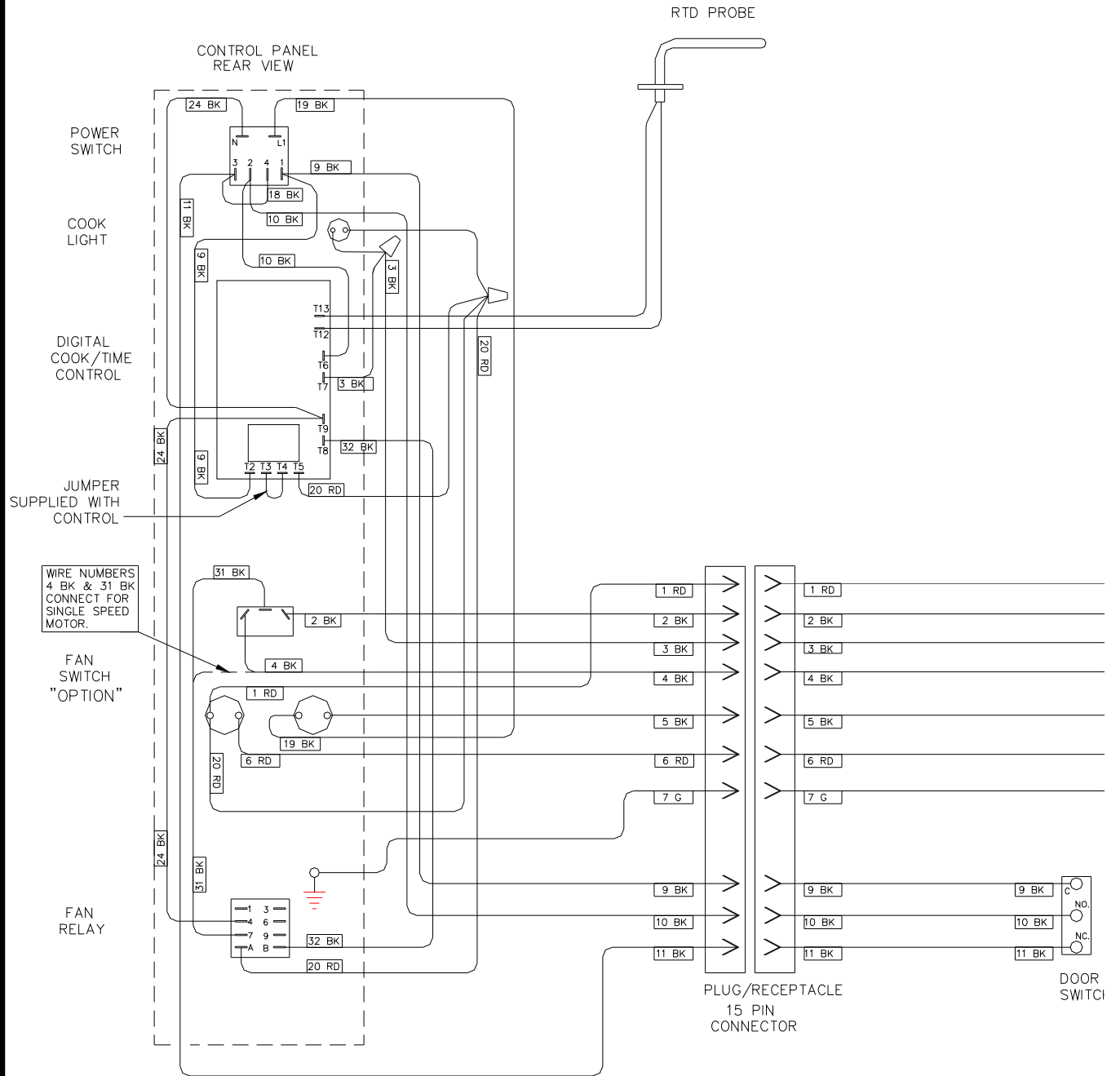

REV	ECO NO.	DATE	BY	DESCRIPTION
A	04243	11/11/04	GKS	RELEASED TO PRODUCTION

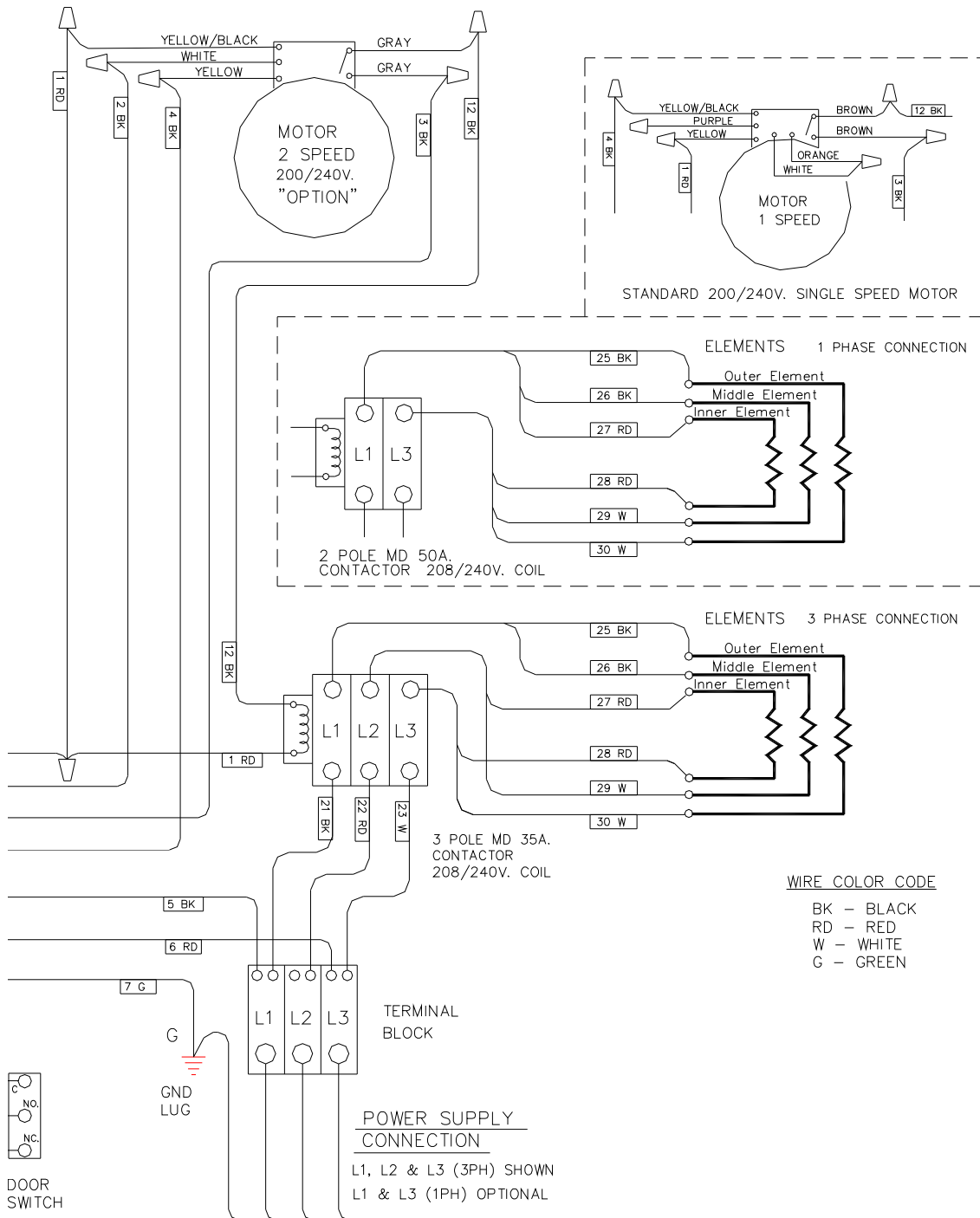

DUKE MANUFACTURING CO.				
MAT'L:	-	TOLERANCE UNLESS NOTED: ±.031 INCHES ±1 DEGREE	DESCRIPTION: DIAGRAM WIRE 5/9 "xx" 208/240 V	
MAT'L P/N:	-	DRAWN BY: G.K.SWANSON	DATE: 11/11/04	
FINISH:	-	CHECKED BY:	DATE:	SCALE: NONE DRAWING NUMBER: 155612W