Duke 59-E3C

ELECTRIC HALF-SIZE CONVECTION OVEN



Installation, Operation, Parts & Maintenance Manual



"Your Solutions Partner"

DUKE MANUFACTURING CO.
2305 N. Broadway, St. Louis, MO 63102
800-735-3853 • 314-231-1130 • 314-231-5074 FAX:
www.dukemfg.com

PN 155409
REV Y 12/07/2017

This Page Intentionally Left Blank

INDEX

59-E3C Electrical Specifications	4
Installation Instructions	
A. Qualified Personnel	5
B. Delivery & Inspection	5
C. Location of Oven	5
D. Ventilation	5
E. Electrical Connections	5
F. Oven Assembly	6
G. Installation	6
H. Adjustments Associated with Installation	6
Control Panel	7
A. Program Oven	8-13
B. Operation of Oven	13
C. Cool Down Operation	13
D. Emergency Back-Up System	14
E. Troubleshooting	14-15
F. Cleaning the Oven	15
Cleaning Instructions	16
Maintenance Instructions	17
A. Adjustments	17
B. Door Adjustments	17
C. Lubrication	17
D. Calibration Check	17
Repair Parts List and Corresponding Drawings	18 - 23
Wiring Diagram	24 - 26

Please supply the Model Number and the Serial Number when ordering replacement parts or requesting service.

We recommend service by Duke Authorized Service Agencies during and after the warranty period.

FOR YOUR SAFETY

Do not store gasoline or other flammable liquids in the vicinity of this appliance.

WARNING

Improper installation, adjustment, service or maintenance can cause property damage, injury or death. Read all installation, operating and maintenance instructions thoroughly before installing or servicing this appliance.

Model 59-E3C

ELECTRICAL SPECIFICATIONS

<u>TOTAL KW</u>	<u>VOLTS</u>	<u>1 PHASE</u>	<u>3 PHASE</u>
8.0	208	41.0 AMPS	24.0 AMPS/PH
8.0	240	36.0 AMPS	21.0 AMPS/PH

Power Supply Connection

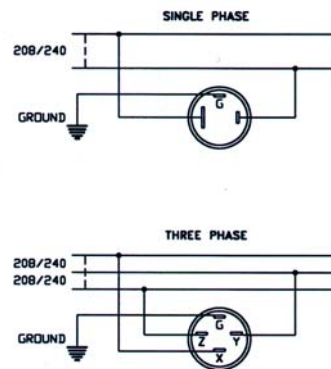
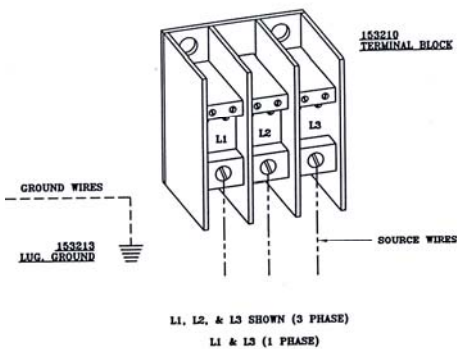

NOTE:
WHEN WIRING WALL RECEPTACLE BE CERTAIN TO WIRE AS SHOWN ABOVE. OVEN MUST BE WIRED SO THAT SUPPLY VOLTAGE MATCHES VOLTAGE ON OVEN RATING PLATE.

INSTALLATION INSTRUCTIONS

A. Qualified Personnel

These installation instructions are for the use of qualified installation and service personnel only. Installation or service by other than qualified service personnel may result in damage to the oven and/or injury to the operator.

Qualified installation personnel are those individuals, firms, companies or corporations which either in person or through an agent are engaged in and responsible for:

- The installation of electrical wiring from the electric meter, main control box or service outlet to the electrical appliance. Qualified installation personnel must be familiar with all precautions required and have complied with all requirements of state and local authorities having jurisdiction.

B. Delivery and Inspection

For transport, ovens are strapped down on wooden skids and surrounded by "tri-wall" cartons to prevent shipping damage. They have been carefully inspected before they were packaged and consigned to the carrier.

Upon Delivery of your Duke oven:

- Look over the shipping container carefully noting any exterior damage on the delivery receipt.
- Uncrate and check for any damage which was not evident on the outside of the shipping container. The carrier must be notified within fifteen (15) days of the delivery of the oven and the carton, skid and all packaging materials must be retained for inspection.

Duke Manufacturing Co. cannot assume liability for loss or damage suffered in transit. The carrier assumes full responsibility for the delivery in good order when the shipment was accepted. If you need assistance in preparing a freight claim call Duke Manufacturing Co.

C. Location of the Oven

Proper planning and placement of the oven is required for the proper function of the oven. Please do consider the following requirements:

- The oven should be placed in an area which is free from drafts and accessible for proper operation and servicing.
- The area around the oven must be kept clear of combustible materials. A minimum of one (1) inch from the left or right side, three (3) inches from the rear and eight (8) inches from the floor must be maintained between the oven and any combustible or non-combustible surface.

D. Ventilation

It is important not to obstruct the cooling system flow of the oven. Do not place any objects on top of the oven. This oven should not be installed on a curb base or sealed to the wall. Either condition can prevent proper ventilation of the oven components.

The blower motor has a thermal protection device, which will trip because of excessive ambient temperatures at the side of the oven. If the device trips continually, this condition should be corrected immediately to avoid damaging the oven permanently.

E. Electrical Connections

Verify the rating plate to be sure the oven specifications concur with the voltage and phase to be supplied to the oven. The rating plate and serial number data are located behind the motor access cover on the right side panel.

The following installation steps should only be conducted by authorized service personnel or a qualified electrician.

Your oven is supplied for connection to a 208 or 240 volt, 1-phase or 3-phase grounded circuit.

Before making any connections to these units, check the rating plate to assure that the voltage and phase rating of the oven is compatible with the electrical supply. All ovens must be electrically grounded in accordance with local codes. In the absence of local codes, the National Electrical Code, ANSI/NFPA 70-1990 (in Canada - CSA Std. C22.1) applies.

Wiring diagrams are located on the inside of the motor access panel, on the right side of the oven.

F. Oven Assembly

Before assembling and installing the oven, please check to make sure that all necessary parts are present. The contents of the package should contain a detailed packaging list. Depending on the specified equipment, the shipped package also should contain:

- Mounting equipment (legs, casters, feet)
- Rack frame and oven racks (in the cavity)

G. Installation

The following installation steps should only be conducted by authorized service personnel.

Leg Attachment (in lieu of stand)

- Once the oven has been removed from the carton, lay it on its left side (the side without the controls).
- Hold the leg and align with the matching holes in base and leg flange. Carefully start the 5/16 18 bolts, (avoid cross-threading), by turning clockwise and tighten to the nearest full turn. A total of (12) 15/16-18 X 3/4 bolts, flat washers and lock washers are required to secure all legs.
- Once legs are secured, add two (2) storage shelves between the four (4) legs. Secure these by using the 1/4-20 X 3/4 self-threading screws. After completion, carefully lift the oven to an upright position.

To level the unit, raise or lower the adjustable feet as required.

H. Adjustments Associated with Installation

Each oven section and all its components parts have been tested thoroughly and inspected before your oven was shipped from the factory. However, it is sometimes necessary to further test or adjust the oven once it has been installed. Such adjustments

are the responsibility of the Dealer or Installer. These types of adjustments are not considered defects, rather a normal and routine part of the proper installation of the equipment.

These adjustments include but are not limited to:

- adjustments and recalibration of the controller
- adjustment to the doors, leveling
- and tightening of fasteners.

No installation should be considered complete without proper inspection and, if necessary, any adjustments by qualified service or installation personnel.

Oven Controls

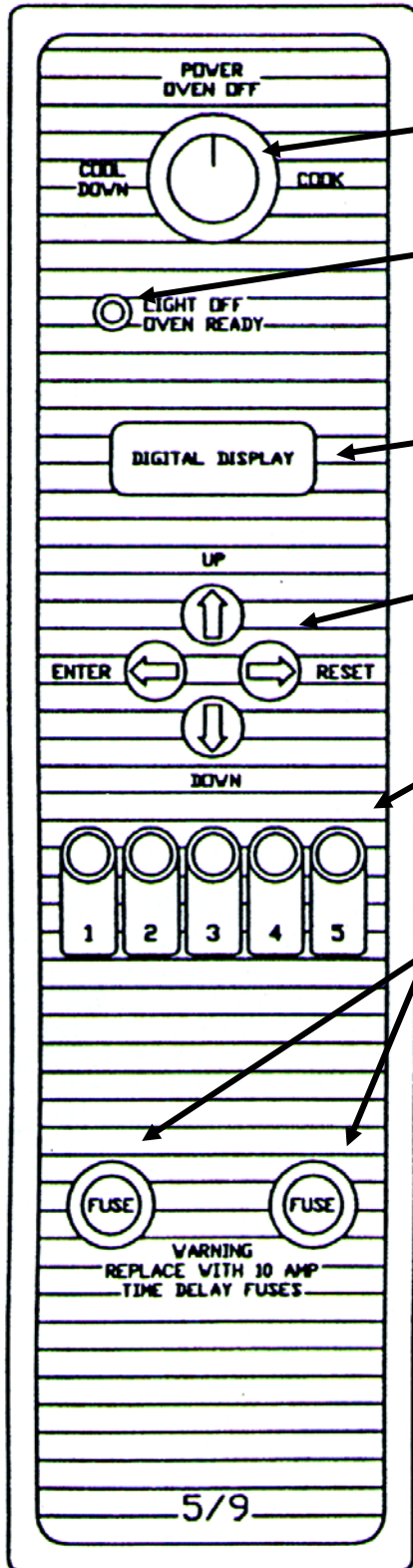

1 Main Power ON/OFF Switch

2 Power On Light -Indicates elements are on. Light will go out when set temperatures has been reached.

3 Indicates Time and/or Temperature

4 UP/DOWN Programming Keys

5 Preprogrammed buttons for 1 through 5 different recipe settings.

6 10 Amp Time Delay Protective Fuses

A. Programming Oven

PROGRAMMING DUKE OVENS

For additional information on Duke Ovens including authorized service representatives and replacement Operation Manual call (800) 735-3853 or www.dukemfg.com

OVEN RACK POSITIONING

To help ensure proper baking, oven racks should be on the 3rd, 6th, and 9th rungs (counting from the bottom rack first).

PROGRAMMING PARAMETERS

	Button 1	Button 2	Button 3	Button 4	Button 5
# of Trays / Product	1	2	3	Mac & Chz 1	Mac & Chz 2
Cook Time	10:00	11:30	11:30	9:00	11:00
Temperature	375°	375°	375°	375°	375°
On Time	60	85	100	60	85
Duty Cycle	160	160	160	160	160
Offset	30	30	30	30	30
Shelf Position	6	6 & 9	3, 6 & 9	6	3 & 6

Timer Button #	Use	Timer Button #	Use
1	One pan of biscuits	2	Two pans of biscuits
3	Three pans of biscuits	4	One pan of Mac & Cheese
5	Two pans of Mac & Cheese		

COOK TIME SETTING PROCEDURES BUTTON 1 – 10:00 MINUTES

Step 1 (Change Time)

Press number 1 and number 5 buttons at the same time (Display will show 1)

Step 2

Press button #1 (Display will show 2)

Step 3

Press button #1 (Display will show current bake time)

Step 4

Use up/down arrows to change baking time to desired time (10:00)

Note: To change seconds in some models, hold in the start (#1) button then use Up / Down Arrows to change seconds

Step 5

Press enter button to store change

Now test timer button number 1 to make sure it times for 10:00 minutes

COOK TIME SETTING PROCEDURES**BUTTON 2 & BUTTON 3 – 11:30 MINUTES**

Step 1 *(Change Time)*

Press number 1 and number 5 buttons at the same time (Display will show 1)

Step 2

Press button #1 (Display will show 2)

Step 3

Press button #2 (Display will show current bake time)

Step 4

Use up/down arrows to change baking time to desired time (11:30)

Note: To change seconds in some models, hold in the start (#2) button then use Up / Down Arrows to change seconds

Step 5

Press enter button to store change

Step 6 *(Change Time)*

Press number 1 and number 5 buttons at the same time (Display will show 1)

Step 7

Press button #1 (Display will show 2)

Step 8

Press button #3 (Display will show current bake time)

Step 9

Use up/down arrows to change baking time to desired time (11:30)

Note: To change seconds in some models, hold in the start (#2 or #3) button then use Up / Down Arrows to change seconds

Step 10

Press enter button to store change

Now test timer button number 2 and 3 to make sure it times for 11:30 minutes

COOK TIME SETTING PROCEDURES**BUTTON 4 – 9:00 MINUTES (MAC & CHEESE)**

Step 1 *(Change Time)*

Press number 1 and number 5 buttons at the same time (Display will show 1)

Step 2

Press button #1 (Display will show 2)

Step 3

Press button #4 (Display will show current bake time)

Step 4

Use up/down arrows to change baking time to desired time (9:00)

Note: To change seconds in some models, hold in the start (#4) button then use Up / Down Arrows to change seconds

Step 5

Press enter button to store change

Now test timer button number 4 to make sure it times for 9:00 minutes

COOK TIME SETTING PROCEDURES BUTTON 5 – 11:00 MINUTES (MAC & CHEESE)

Step 1 *(Change Time)*

Press number 1 and number 5 buttons at the same time (Display will show 1)

Step 2

Press button #1 (Display will show 2)

Step 3

Press button #5 (Display will show current bake time)

Step 4

Use up/down arrows to change baking time to desired time (11:00)

Note: To change seconds in some models, hold in the start (#5) button then use Up / Down Arrows to change seconds

Step 5

Press enter button to store change

Now test timer button number 5 to make sure it times for 11:00 minutes

ON TIME SETTING PROCEDURES BUTTON 1

Step 1 *(Change On Time)*

Press number 1 and number 5 buttons at the same time (Display will show 1)

Step 2

Press button #3 (Display will show 2)

Step 3

Press button #1 (Display will show current on time)

Step 4

Use up/down arrows to change the on time to desired setting (60)

Step 5

Press enter button to store change

ON TIME SETTING PROCEDURES BUTTON 2

Step 1 *(Change On Time)*

Press number 1 and number 5 buttons at the same time (Display will show 1)

Step 2

Press button #3 (Display will show 2)

Step 3

Press button #2 (Display will show current on time)

Step 4

Use up/down arrows to change the on time to desired setting (85)

Step 5

Press enter button to store change

ON TIME SETTING PROCECDURES BUTTON 3

- Step 1 *(Change On Time)*
Press number 1 and number 5 buttons at the same time (Display will show 1)
- Step 2
Press button #3 (Display will show 2)
- Step 3
Press button #3 (Display will show current on time)
- Step 4
Use up/down arrows to change the on time to desired setting (100)
- Step 5
Press enter button to store change

ON TIME SETTING PROCECDURES BUTTON 4

- Step 1 *(Change On Time)*
Press number 1 and number 5 buttons at the same time (Display will show 1)
- Step 2
Press button #3 (Display will show 2)
- Step 3
Press button #4 (Display will show current on time)
- Step 4
Use up/down arrows to change the on time to desired setting (60)
- Step 5
Press enter button to store change

ON TIME SETTING PROCECDURES BUTTON 5

- Step 1 *(Change On Time)*
Press number 1 and number 5 buttons at the same time (Display will show 1)
- Step 2
Press button #3 (Display will show 2)
- Step 3
Press button #5 (Display will show current on time)
- Step 4
Use up/down arrows to change the on time to desired setting (85)
- Step 5
Press enter button to store change

Note: The below settings for Temperature, Duty Cycle and Offset Setting, apply to all timer buttons and should never vary from the recommended Settings

TEMPERATURE SETTING

IMPORTANT NOTE: Display will show 375° actual temperature is approximately 400°

Step 1 *(Change Temperature)*

Press number 1 and number 5 buttons at the same time (Display will show 1)

Step 2

Press button #2 (Display will show the current temperature)

Step 3

Use up/down arrows to change the on time to desired setting (375)

Step 4

Press enter button to store change

DUTY CYCLE SETTING

Step 1 *(Change Duty Cycle)*

Press number 1 and number 5 buttons at the same time (Display will show 1)

Step 2

Press button #4 (Display will show the Duty Cycle Value)

Step 3

Use up/down arrows to change the Duty Cycle Value to desired setting (160)

Step 4

Press enter button to store change

OFFSET SETTING

Step 1 *(Change Offset)*

Press number 1 and number 5 buttons at the same time (Display will show 1)

Step 2

Press button #5 (Display will show the current Offset Value)

Step 3

Use up/down arrows to change the Offset value to desired setting (30)

Step 4

Press enter button to store change

CONTROLLER RESET

In rare situations, such as a lightning strike near the restaurant, the computer may lose its program, or become "locked up". If this should happen, press the RESET switch to reset the computer, or turn the power to the oven off and back on. Resetting the computer resynchronizes its program flow.

B. Operation of the Oven

Operation of the computerized Auto Rack Load Controller is quite simple.

Preheat: Close oven door and turn power knob clockwise to "cook" position.

The digital display will illuminate and display a temperature of 212° (the minimum displayed temperature). The amber light will also be lit indicating the oven is heating. When the oven temperature begins to exceed 212°, the actual oven temperatures will be displayed until the temperature set point has been reached and the oven ready light has gone off. At this point, the display shows 9:00 minutes, the cook time for one tray. Always keep oven door closed until biscuits are ready to be loaded onto a rack.

Baking: Open door and quickly load tray(2). (Slide tray all the way to the back wall, then slide forward one inch.) Close door and press the switch that corresponds to the number of trays to be loaded (1,2, or 3).

The pressed switch will illuminate, indicating baking has begun. The time displayed begins counting down. When bake cycle is complete, the switch you originally pressed will flash and the alarm sounds. Press the flashing switch to turn off alarm. Remove the product.

Rack Positions: 3,6 and 9 counting from bottom up.

1 tray: Use top rack position. Press switch #1.
2 trays: Use top and middle rack positions. Press switch #2.
3 trays: Use Top, middle and bottom positions. Press switch #3

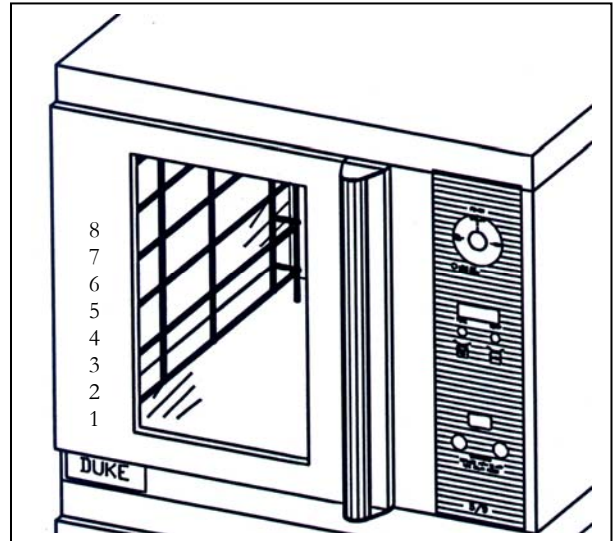

C. Cool Down Operation

The oven has a cool down feature to expedite cooling of the oven interior so that it can be cleaned.

To initiate the cool down feature, turn the power switch counter clockwise to the off position. Open door and turn the power switch counter clockwise to the cool down positions. The oven fan will only operate, circulating cool air in the oven cavity.

When the oven interior is cooled sufficiently, turn the power switch clockwise to the off position. Begin the daily cleaning procedures.

D. Emergency Back-Up System

Your oven is equipped with an emergency back-up system to be used should the computer controller ever malfunction. ***It is intended only to be used to keep you in operation until a service agent arrives to provide repairs.***

Operation: Turn power switch to off position. Push the toggle switch located on the right access panel of the oven to the up position.

Turn power switch clockwise to cook position. The oven will now maintain a temperature of 375° by the back up thermostat. You will need to manually time your bake cycle until the biscuits are baked. No display will be illuminated.

Call your local authorized service agent to render repairs as soon as possible.

E. Troubleshooting (Only by an authorized service agent)

Oven Not Heating

1. Oven heating lamp is off.
2. Digital display in the controller is not lit. (Make sure backup thermostat control switch is in the down position.)
3. Check the 24VAC from the transformer. If voltage is present, replace the controller.
4. If no voltage, check the transformer and transformer input voltage. Make certain the correct transformer input voltage taps are used.

Transformer Primary	Voltage
Orange	240-L1
Red	208-L1
WHITE	120-L1
BLACK	L2

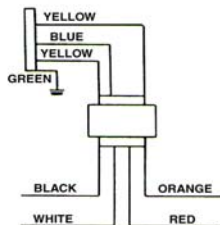

Transformer Secondary

	Voltage
Yellow-blue	12V (pin 4 & pin3)
Yellow-blue	12V (pin 2 & pin3)
Yellow-yellow	24V (pin 4 & pin 2)

DIGITAL DISPLAY IN THE CONTROLLER IS LIT, OVEN NOT HEATING

A simple test.

1. Turn the oven off.
2. Disconnect the oven control connector to J1 on the PCB
3. Insert a short insulated jumper wire between pins 1 and 3 in the oven control connector. Make sure the wire is insulated and bare wire cannot touch ground or other metal parts. (CAUTION: Line voltage present.)
4. Turn the oven on.
5. If the oven heats up, turn the oven off, remove the jumper from the oven control connector, and replace the oven control connector. Check the controller's setpoint. If the setpoint is correct, replace the controller.
6. If the oven does not heat up, the problem is within the oven.
7. Turn the oven off.
8. Remove the jumper wire and replace the connector.
9. Oven Heating Lamp is on. The problem is within the oven.

OVEN TOO HOT (OVEN STAYS ON)

1. Turn the oven off.
2. Disconnect the oven control connector (J1)
3. Turn the oven on.
4. If the oven heats up, the problem is within the oven.
5. If the oven does not heat up, turn the oven off, and replace the oven control connector on J1, then turn the oven back on. Proceed to 6.
6. Press the ENTER switch to read the oven's temperature.
7. Indicated temperature is obviously less than it should be.
8. The thermocouple cable may be shorted, or,
9. The controller may be defective.
10. Replace the temperature probe.
11. If the temperature now indicates the correct temperature, the problem was the temperature probe.
12. If the temperature still indicates lower than expected, replace the controller.

OVEN NOT RECOVERING WHEN BAKING

1. Check the Duty Cycle ON-TIME setting.
2. Measure the actual ON-TIME and OFF-TIME with a stopwatch or use the second hand of a wristwatch or clock to see if the oven is being controlled properly.
3. If the oven turns on and off at the proper times, the fault is within the oven. Check amp draw to each element. Be certain oven is supplied with proper voltage. (240 volt elements on 208 volt power supply, for instance.)
4. If the oven does not turn on and off at the proper times, replace the controller.

BISCUITS TOO DARK (OVER BAKED)

1. Reduce the duty Cycle ON_TIME until the biscuits are the correct brownness.

BISCUITS TOO LIGHT (OVER BAKED)

1. Increase the Duty Cycle ON-TIME until the biscuits are the correct brownness.

Control Failure Diagnostics

There are two types of failures that will shut down the oven and display numbers that indicate the cause of the trouble:

1. Temperature Probe Opens

Should the controller's probe/cable become an open circuit following occur:

- A. The oven is turned off
- B. The alarm begins beeping
- C. The display will show four (4) nines (9999)

Press one of the five START switches to turn off the alarm.

Replace the probe/cable.

2. Oven Stays On Too Long

If the oven stays ON for over fifteen (15) minutes, and this ON condition is caused by the controller receiving an improper temperature signal, the following will occur.

- A. The oven is turned off.
- B. The alarm begins beeping
- C. The display will show four (4) sevens (7777)

Press one of the START switches to turn off the alarm.

Check the probe's temperature by pressing the ENTER switch. If the indicated temperature is less than the actual oven temperature, the probe cable is probably shorted, causing a second thermocouple at a lower temperature. Replace the thermostat probe/cable.

If the temperature shown in the display is about the same as that of the oven's, the problem is probably the Controller. Replace the controller.

F. Cleaning of the Oven

The stainless steel on your oven can be kept clean with a good stainless steel cleaner, many of which are on the market. The painted surfaces should be wiped clean regularly with a MILD detergent. Moisten a cloth and wipe down the oven while it is COLD. Wiping down an oven while it is hot will cause streaking and otherwise unsatisfactory results. Once the oven is clean, it can be wiped down with light oil.

Porcelain oven interiors should be cleaned regularly using a degreasing agent. For heavier deposits a commercial oven cleaner such as Dow Oven Cleaner, Easy-Off, or Mr. Muscle can be used. Care must be taken to prevent these alkaline-type cleaners from coming in contact with any aluminized steel surfaces in the oven, including the blower wheel.

The racks and rack supports can be removed and soaked in a solution of ammonia and water.

Make certain that all parts are thoroughly rinsed before returning to use.

NOTE: Never steam clean or hose down with water. Electric component will fail due to moisture.

DAILY



CLEANING INSTRUCTIONS

1. Clean the porcelain interior using a degreasing agent. For heavier deposits a commercial oven cleaner such as Dow Oven Cleaner, Easy-Off or Mr. Muscle can be used.
2. Clean exterior painted surfaces with warm water and a mild detergent. Moisten a cloth and wipe down the oven while it is COLD.
3. Clean Stainless steel on the oven with a good stainless steel cleaner.
4. Make sure that all parts are thoroughly rinsed before returning to use.

!Caution!

Do not use caustic cleaners, acids, ammonia products or abrasive cleaners or cloths. These can damage the stainless steel and door gaskets.

Never steam clean or hose down with water. Electric component will fail due to moisture.

WEEKLY

The racks and rack supports can be removed and soaked in a solution of ammonia and water. Make certain that all parts are thoroughly rinsed before returning to use.

MONTHLY

1. Check door handle screws for tightness.

THREE MONTHS

1. Check the door gasket seal on the oven and proofer for leaks. See the section on Door Adjustments and Gasket Maintenance for help.

SIX MONTHS

Before performing control panel maintenance, main distribution panel circuit breaker for oven must be turned off. This maintenance should be performed by Qualified Maintenance Personnel only. Read and follow the manufacturers instructions, Material Safety Data Sheets (MSDS) and Workplace Hazardous Material Information Systems (WHMIS) before using any type of cleaning chemicals, degreaser, etc.

1. Clean Control Panel Mylar using a mild degreaser and water.
2. Clean Control Compartment Interior – Use commercial electronic component spray (if necessary) to de-grease the control compartment (see Note above).
3. Inspect/Replace any or all wiring which is saturated with oil.
4. Inspect Oven Door-lubricate door plunger assembly and strike plate with food grade high temperature lubricant such as Lubriplate FGL-1, adjust door as necessary
5. Inspect Element Wire Connections-take amp readings of elements.
6. Inspect Blower Motor – Degrease as necessary
7. Inspect Blower Wheel – Clean with ammonia and water solution.
8. Inspect Back-up Thermostat – Check calibration.

MAINTENANCE INSTRUCTIONS

These maintenance instructions are for the use of qualified service personnel only. Service by other than qualified personnel may result in damage to the oven and/or injury to the operator.

Qualified service personnel are those individuals, firms, companies or corporations which either in person or through an agent are engaged in and responsible for repair or servicing of commercial food preparation equipment, who are experienced in such work, familiar with all precautions required, and have complied with all requirements of state and local authorities having jurisdiction.

If you should require assistance in the selection of a qualified service agency, please contact Duke Manufacturing Co.'s Service Department at 800-735-3853.

A. Adjustments

Quite often malfunctions which are attributed to defects may be repaired by adjusting certain parts rather than replacing them.

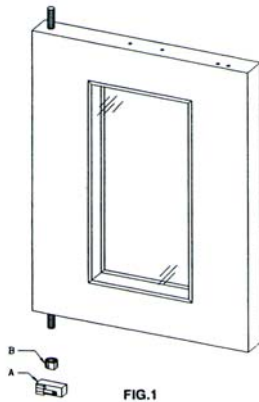

B. Door Adjustment

The door switch is located behind the lower front cover, on the right or left side. (Fig.1) The door switch (A) is activated by a cam (B) which is mounted to the door's hinge pin with a set screw. Position the door so it is nearly closed but not latched. To adjust the cam:

- Loosen the set screw and rotate the cam until you hear the switch click.
- Tighten the set screw in the cam.
- Test the door to make certain the switch will make contact with the doors closed.
- Torque the setscrew to 60 in-lbs.
- Replace the compartment cover.

C. Lubrication

The door plunger assembly requires periodic lubrication by the operator to ensure smooth, trouble-free operation.

Application of a Food Grade High Temperature Lubricant such as Lubriplate FGL-1 is recommended at least bimonthly. Apply lubricant to the plunger and strike plate sparingly. If necessary, lubricate at more frequent intervals.

D. Back-up thermostat calibration check:

- Turn the oven on by turning the Power Switch to the ON position.
- Open the doors and place a thermocouple in the center of the middle oven rack. A reliable mercury-type thermometer can be substituted if a pyrometer is not available.
- Turn the power switch to the off position.
- Turn the thermostat dial to 375°F (177°C). Allow the oven to preheat ½ hour.
- Note the maximum and minimum temperatures through several cycles.
- If the reading on the pyrometer (or thermometer) is less than 10°F different from the setting of the thermostat, no adjustment is needed. If this reading is more than 10°F, proceed with calibration procedure.

To Recalibrate:

- Remove the thermostat knob by loosening the setscrew and pull the knob forward. Take care not to rotate the thermostat stem, which will change the setting.
- With a very small screwdriver, turn the screw located in the bottom of the hollow of the stem clockwise to lower the temperature of counterclockwise to raise the temperature. DO NOT allow the stem of the thermostat to rotate as you turn the screw.

Caution: Maximum turn of screw "A" is 1-1/2 turns – clockwise or counterclockwise.

This thermostat is a direct-acting (opens on temperature rise) device.

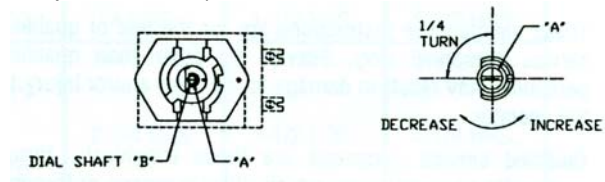

Model 59-E3C Half-Size Electric Convection Oven Repair Parts List

<u>Item #</u>	<u>Part #</u>	<u>Description</u>
1	155302	Mylar
2	153142	Knob, control
3	153204	Light, oven ready, 208v/240v
4	153200	Holder, fuse
5	153201	Fuse, 10 amp
6	153460	Switch, rotary
7	155301	Transformer 208/240V
	155995*	Transformer 480/240V 2kVA
8	600108	Controller (Used after July 1998)
8	155526	Controller Conversion Kit (Used prior to July 1998)
9	155304	Probe
10	153210	Terminal block
11	153156	Contact, 208v/240v, 3-pole, 50 amp
12	153034	Motor, 208/240v, 1-speed
13	153093	Fan Wheel
14	155079	Element, outer, 240v, 2.667 KW
14	155076	Element, outer, 208v, 2.667 KW
15	155078	Element, center, 240v, 2.667 KW
15	155075	Element, center, 208v, 2.667 KW
16	155077	Element, inner, 240v, 2.667 KW
16	155074	Element, inner, 208v, 2.667 KW
17	155113	Support, rack, oven
18	155114	Rack, oven
19	155404	Handle, door
20	155451*	door, with glass hinged right
	155454	Door, with glass hinged left
21	155132	Glass only
22	155107	Actuator, door switch
23	148077	Switch, micro, door
24	153056	Bearing, door
25	155007	Gasket, door top
26	155006	Gasket, door bottom
27	155008	Gasket, door side (2)
28	153416	Catch, door
29	153801	Latch, roller assembly
30	155318	Switch, toggle, back up system
31	149403	Thermostat, backup
32	153142	Knob, backup thermostat
33	153588	Overlay, backup thermostat
34	600100	Kit, Flue Guard (Optional)
35	155125	Bracket Stacking
36	155309*	Harness, Electronic Panel

* NOT SHOWN

Diagrams of parts on following pages

MODEL 59E3C OVEN CONTROLS

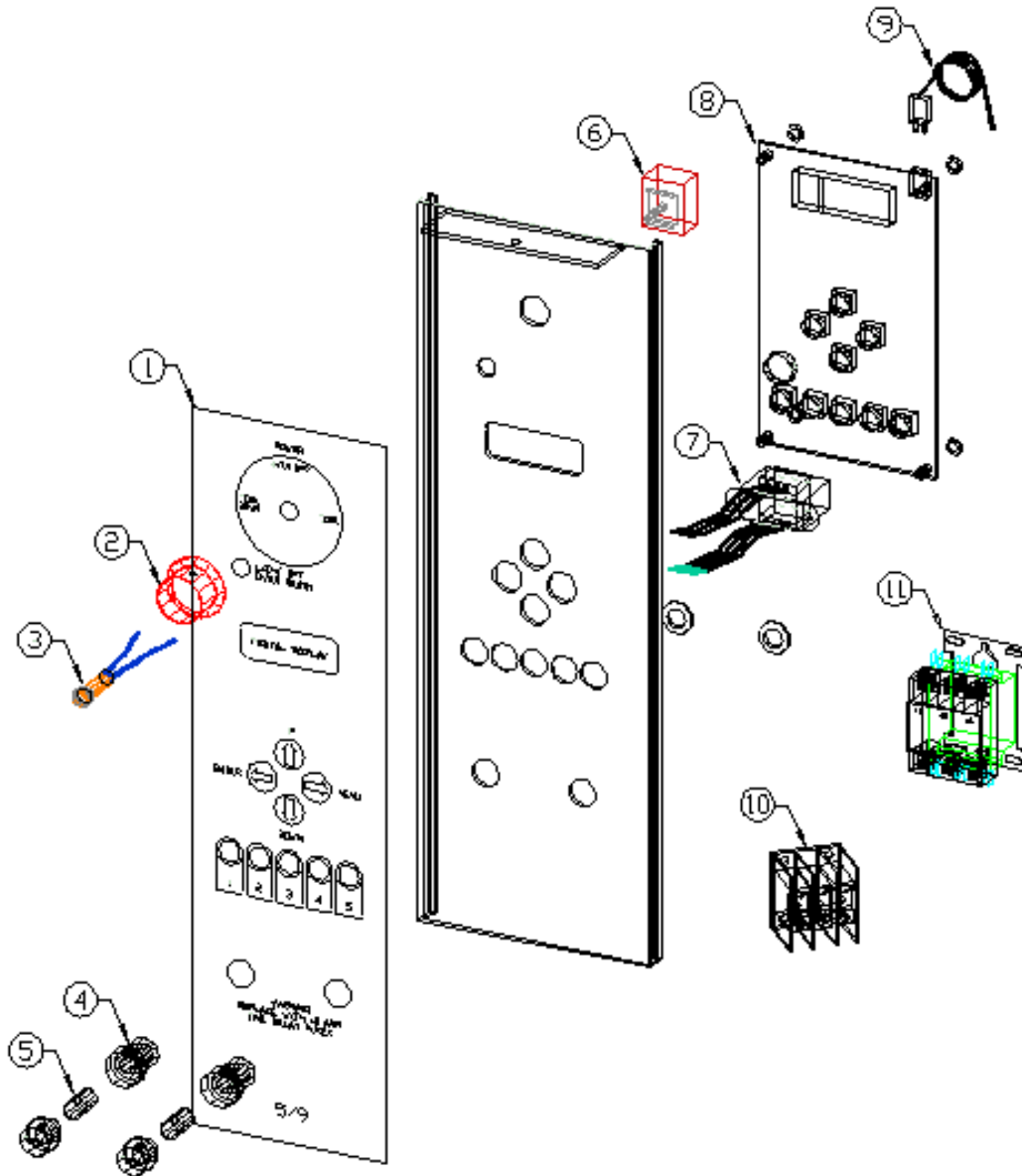

INTERIOR OVEN COMPONENTS

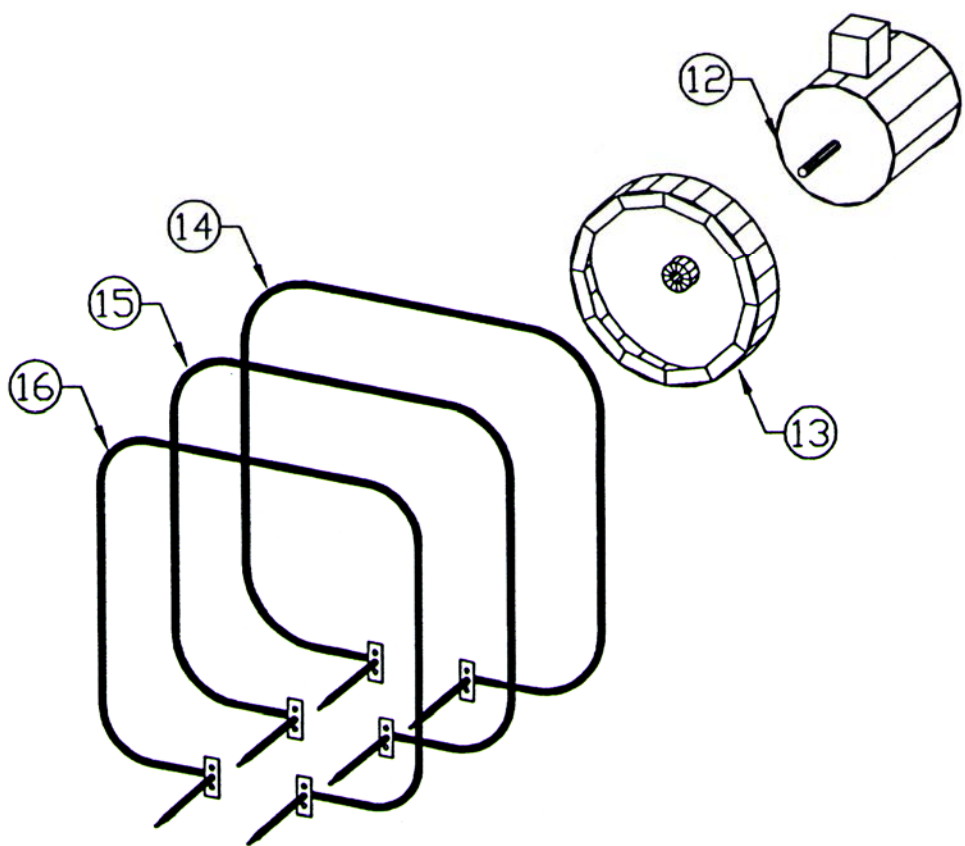
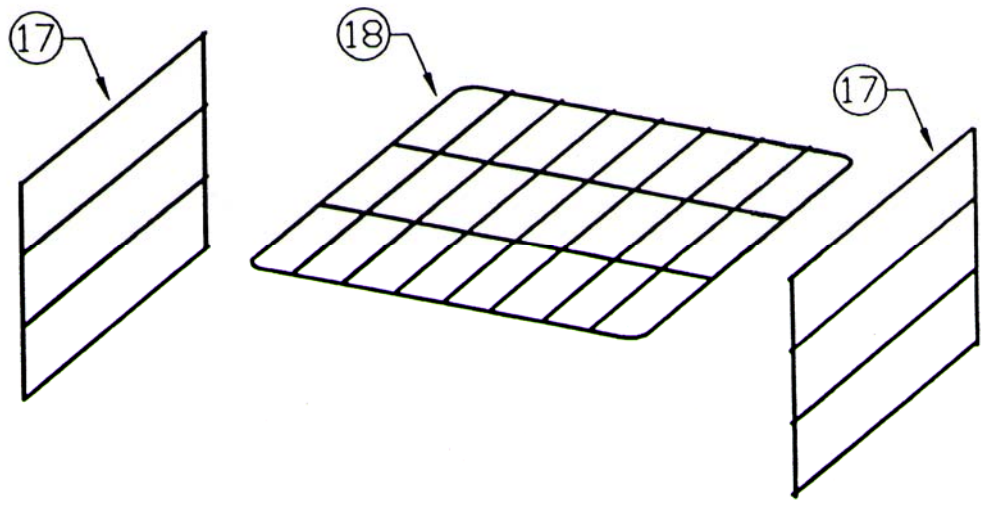

MODEL 59-E3C DOOR ASSEMBLY

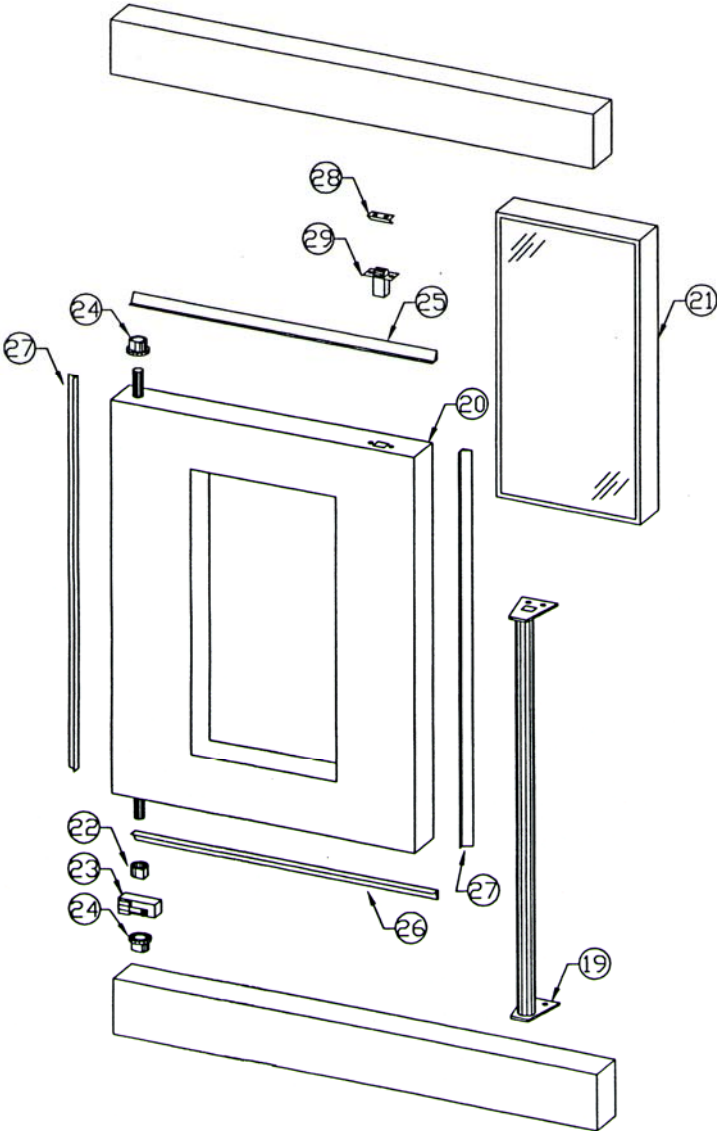

OVEN BACKUP THERMOSTAT SYSTEM

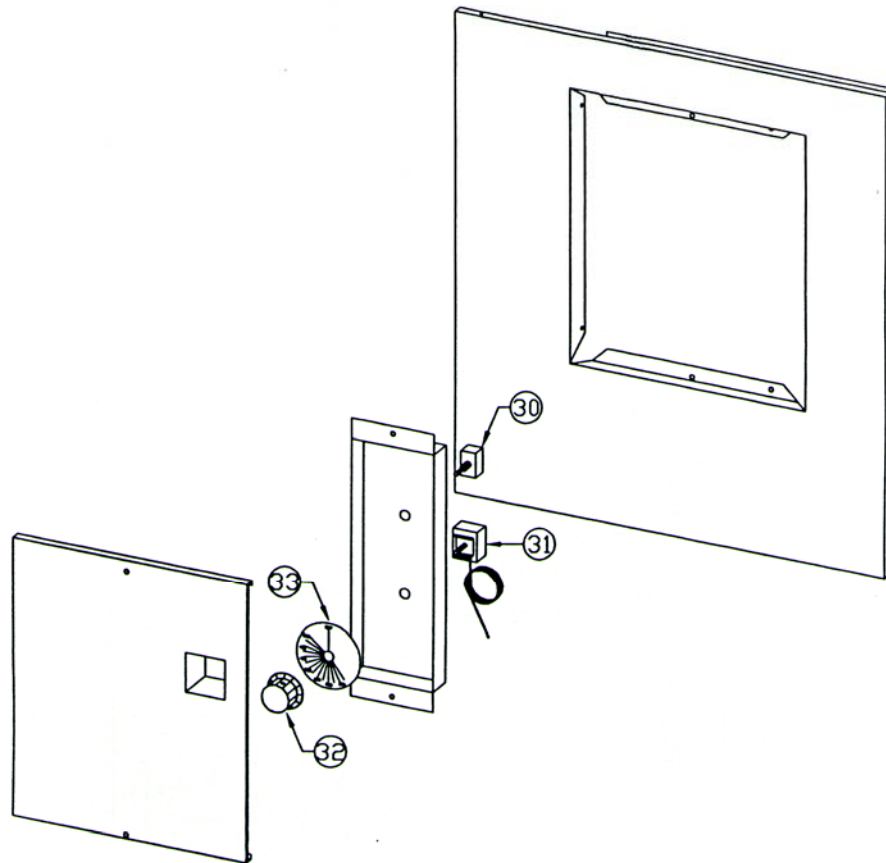

FLUE GUARD

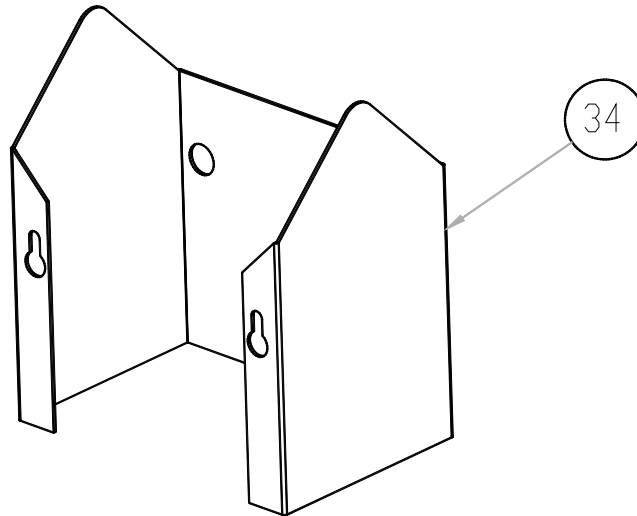

Securing Double Stacked Ovens

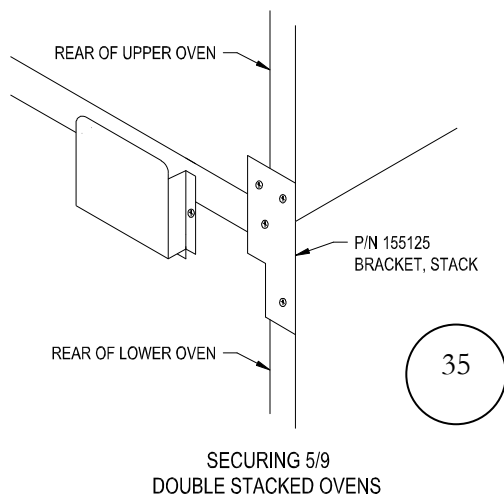

- 1.) On rear of top oven remove two existing screws that are located at the lower right hand corner.
- 2.) On rear of bottom oven remove two existing screws that are located at the upper right hand corner.
- 3.) Install stacking bracket using the existing screws as shown in figure.
- 4.) Repeat steps to install 2nd stacking bracket on left hand side.

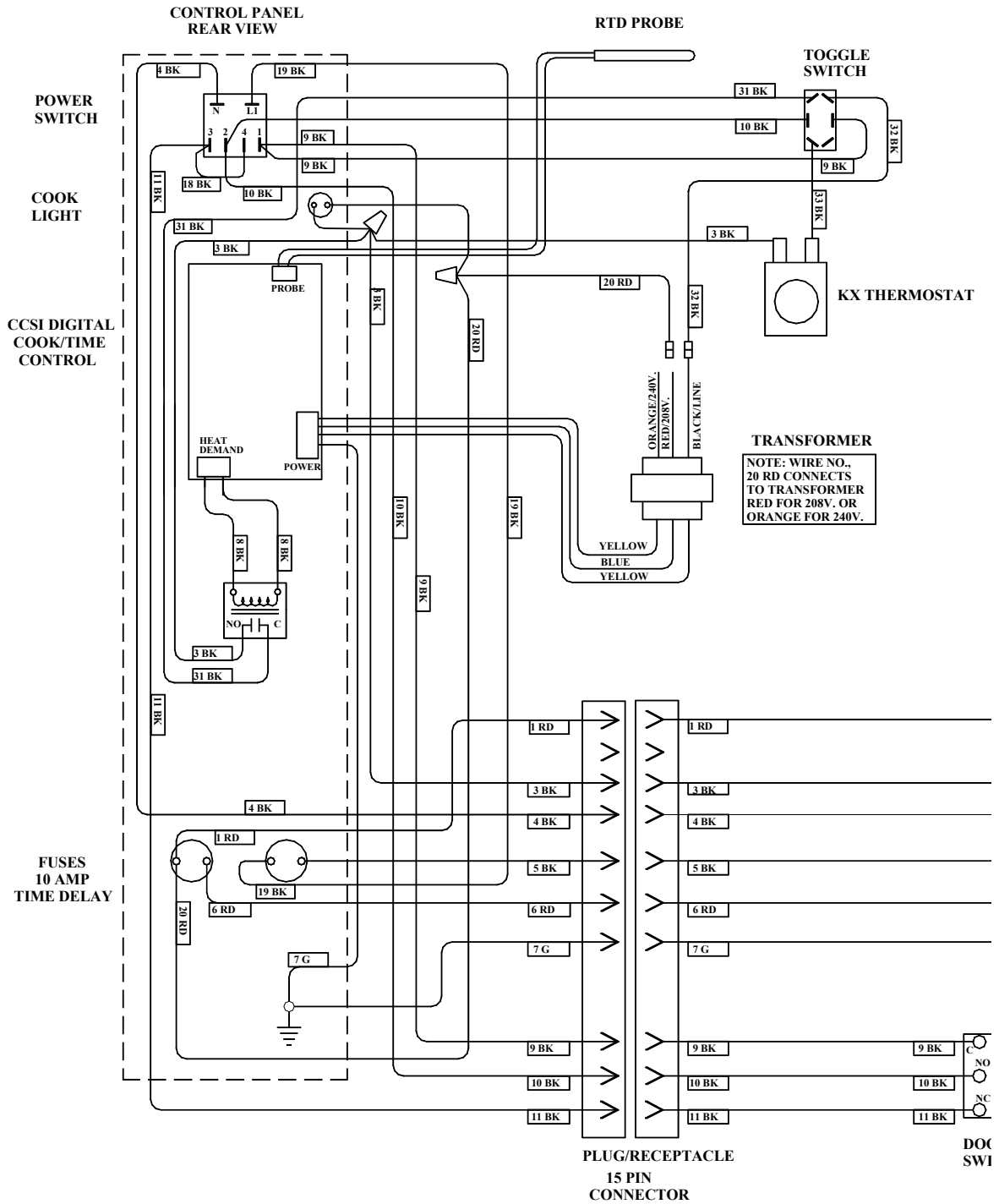

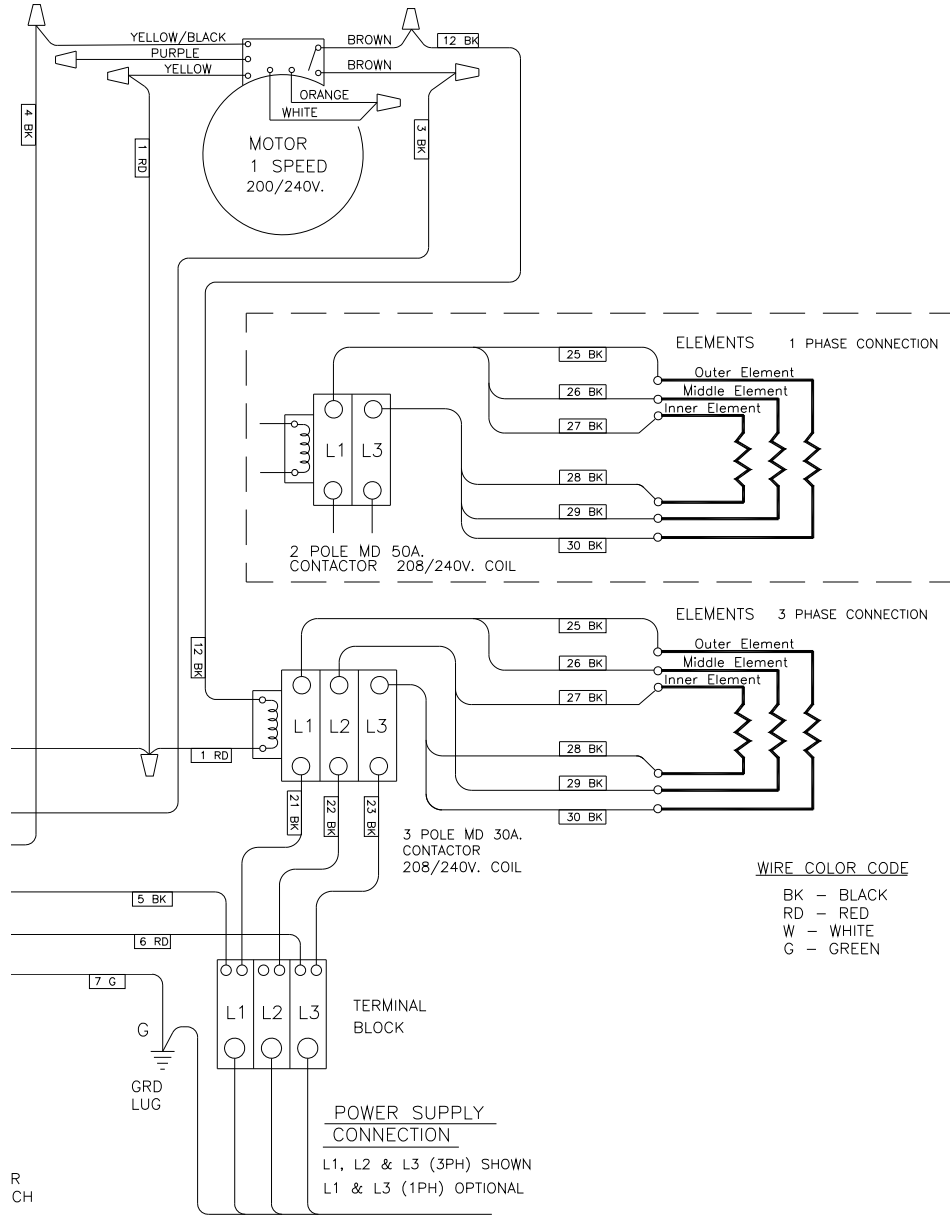

SCHEMATIC DIAGRAM FOR MODELS 5/9 "CCSI" CONTROL W/BACKUP THERMOSTAT, 480 VAC. 50/60 HZ, 1PH OR 3PH.

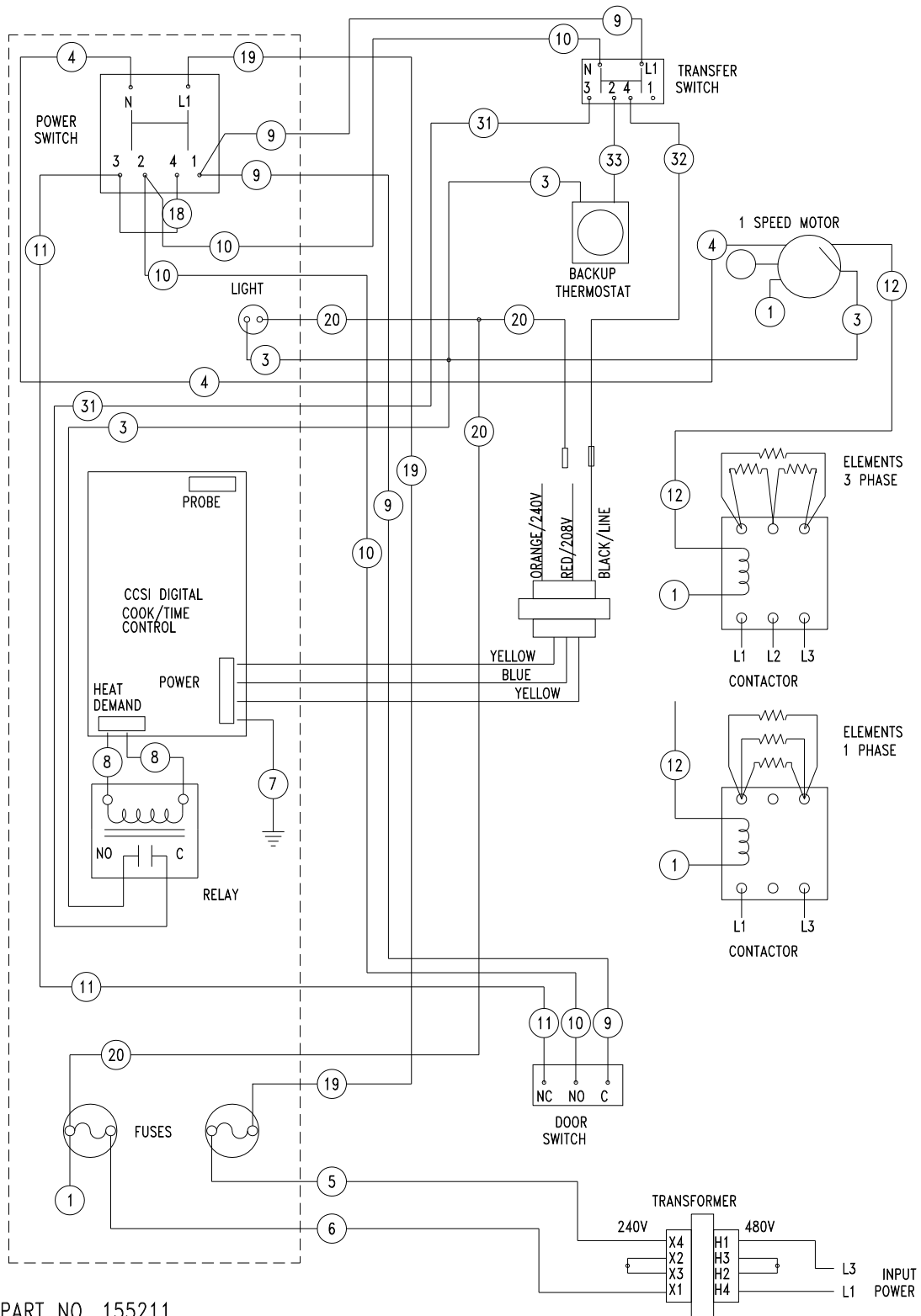

PART NO. 155211

This Page Intentionally Left Blank



Your Solutions Partner

Duke Manufacturing Co.

2305 N. Broadway

St. Louis, MO 63102

Phone: 314-231-1130

Toll Free: 1-800-735-3853

Fax: 314-231-5074

www.dukemfg.co