

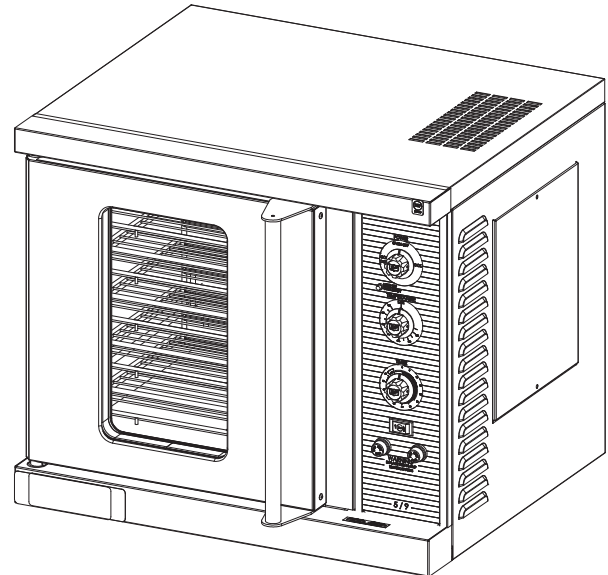

Your Solutions Partner

Installation and Operation Manual

5/9 ELECTRIC HALF-SIZE CONVECTION OVEN



**Please read this manual completely before attempting
to install, operate or service this equipment**

*This manual is Copyright © 2017 Duke Manufacturing Co. All rights reserved.
Reproduction without written permission is prohibited. Duke is a registered
trademark of the Duke Manufacturing Co.*

Duke Manufacturing Co.

**2305 N. Broadway
St. Louis, MO 63102
Phone: 314-231-1130
Toll Free: 1-800-735-3853
Fax: 314-231-5074
www.dukemfg.com**

**P/N: 155131
REV Z 12/07/2017**

TABLE OF CONTENTS

SPECIFICATIONS	3
INSTALLATION INSTRUCTIONS	4
A. QUALIFIED PERSONNEL	4
B. DELIVERY AND INSPECTION	4
C. LOCATION OF THE OVEN	4
D. ELECTRICAL CONNECTIONS	4
E. OVEN ASSEMBLY	5
Leg Attachment	5
Caster Installation.....	5
Double Sections	5
F. ADJUSTMENTS ASSOCIATED WITH INSTALLATION	5
OPERATING INSTRUCTIONS.....	6
THE 5/9 SERIES OF CONVECTION OVENS	6
A. OVEN CONTROLS	7
Electro-Mechanical.....	7
“V” Controller Operating Instructions.....	7
Cooking.....	8
“XX” Controller	9
“XX” Controller Programming & Operating Instructions	9
“ZZ” Controller	11
“ZZ” Controller Programming & Operating Instructions.....	11
B. GENERAL GUIDELINES FOR OPERATION.....	15
C. Suggested Times & Temperatures.....	16
D. COOK & HOLD/ROAST & HOLD RECOMMENDED TIME & TEMPERATURE	17
COOK & HOLD - ROAST & HOLD	17
E. General Guidelines for Cook & Hold - Roast & Hold	18
MAINTENANCE INSTRUCTIONS	19
A. ADJUSTMENTS	19
B. DOOR SWITCH ADJUSTMENT	19
C. THERMOSTAT CALIBRATION	19
Electro-Mechanical Controls "V". Not applicable to Ovens with Solid State Controls....	19
To Check Calibration:	19
To Calibrate the Ovens.....	20
D. CLEANING OF THE OVENS	20
5/9 – ELECTRIC CONVECTION OVEN REPAIR PARTS LIST	21
DOOR ASSEMBLY	22
“V” CONTROLLER ASSEMBLY.....	23
“XX” CONTROLLER ASSEMBLY	24
“ZZ” CONTROLLER ASSEMBLY.....	25
CONTACTOR IDENTIFICATION	26
FLUE GUARD	27
DOUBLE STACK OVENS	27
"V" CONTROLLER WIRING SCHEMATIC	28
"XX" CONTROLLER WIRING SCHEMATIC.....	29
"ZZ" CONTROLLER WIRING SCHEMATIC	30
CUSTOMER ASSISTANCE	31

IMPORTANT WARNING AND SAFETY INFORMATION

FOR YOUR SAFETY:

Do not store or use gasoline or other flammable vapors or liquids in the vicinity of this or any other appliance.

⚠ WARNING: Improper installation, adjustment, alteration, service or maintenance can cause property damage, injury or death. Read the installation, operating and maintenance instructions thoroughly before installing or servicing this equipment.

THIS MANUAL MUST BE RETAINED FOR FUTURE REFERENCE.

SPECIFICATIONS

TOTAL KW	VOLTAGE	AMPS-1 PHASE	AMPS-3 PHASE
8.0 KW	208	41	24
8.0 KW	240	36	21

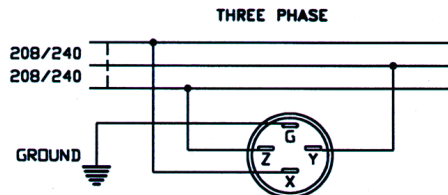
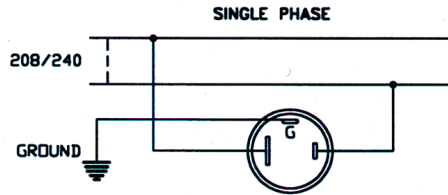
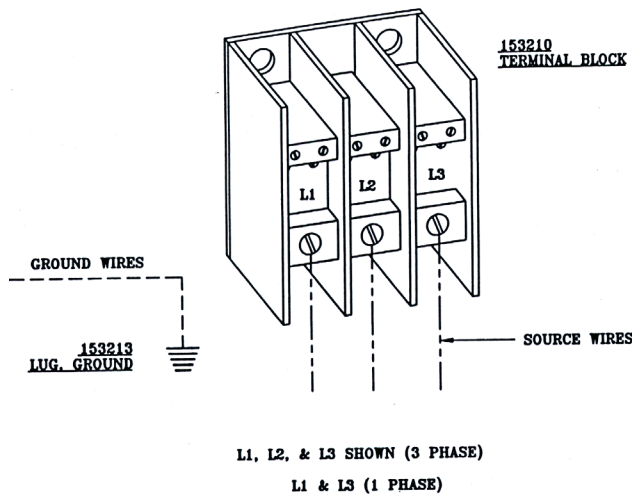

POWER SUPPLY CONNECTIONS

INSTALLATION INSTRUCTIONS

A. QUALIFIED PERSONNEL

These installation instructions are for the use of qualified installation and service personnel only. Installation or service by other than qualified personnel may result in damage to the oven and/or injury to the operator.

Qualified installation personnel are those individuals, firms, companies or corporations which either in person or through an agent is engaged in and responsible for:

- The installation of electrical wiring from the electric meter, main control box or service outlet to the electrical appliance. Qualified installation personnel must be familiar with all precautions required and have complied with all requirements of state and local authorities having jurisdiction. See: National Electrical Code, ANSI/NFPA70.

B. DELIVERY AND INSPECTION

Duke Manufacturing Co. does everything within its power to insure you received your oven in good condition. They are strapped down on heavy wooden skids and surrounded by heavy "tri-wall" cartons to prevent shipping damage. They have all been carefully inspected before they were packaged and consigned to the carrier.

Upon delivery of your Duke oven:

- Look over the shipping container, carefully noting any exterior damage on the delivery receipt, which must also be signed by the driver/ delivery person.
- Uncrate and check for any damage, which was not evident on the outside of the shipping container. This is called concealed damage. The carrier must be notified within fifteen (15) days of the delivery of the oven and the carton, skid and all packaging materials must be retained for inspection.

Duke Manufacturing Co. cannot assume liability for loss or damage suffered in transit. The carrier assumes full responsibility for delivery in good order when the shipment was accepted. However, we are prepared to assist you in filing your claim.

C. LOCATION OF THE OVEN

Proper planning and placement of the oven will give you the best results in terms of long-term user convenience and satisfactory performance. We urge you to give adequate thought in the placement of your oven prior to its arrival.

- The oven should be placed in an area that is free from drafts and accessible for proper operation and servicing.
- The area around the oven must be kept clear of combustible materials. Refer to the Oven Placement Clearances Chart before installing the oven.

OVEN PLACEMENT CLEARANCES CHART

	COMBUSTIBLE	NON-COMBUSTIBLE
Right Side	1"	0"
Left Side	1"	0"
Rear	3"	3"
Floor	8"	8"

It is also important not to obstruct the natural flow of ventilation air if the oven is to operate properly. This oven should not be installed on a curb base or sealed to the wall. Either condition can restrict the flow of air to or prevent proper ventilation of the blower motor. The blower motor has a thermal protection device, which will trip, because of excessive ambient temperatures at the back of the oven. This condition should be corrected immediately to avoid damaging the oven permanently.

The flue located near the top at the rear of the oven must not be obstructed. Proper ventilation is important to avoid high temperatures at the rear of the oven. High temperatures can cause premature blower motor failure.

Before making any connections to the oven, check the specification plate to be sure the oven specifications concur with the voltage and phase to be supplied to the oven.

The specification plate is located behind the lower front panel. To access the specification plate, loosen the four screws below the doors, and pull the panel outward.

The specification plate bearing the oven's serial number is attached to the underside of the upper ledge above the control panel.

D. ELECTRICAL CONNECTIONS

The oven is supplied for connection to a 208 or 240 volt grounded circuit. The electric motor, indicator lights and control circuits are connected internally and require no secondary power supply.

Before making any connections to these units, check the specification plate to assure that the voltage and

phase of the oven is compatible with the electrical supply. When installing, all ovens must be electrically grounded in accordance with local codes or in the absence of local codes, with the National Electrical Code, ANSI/NFPA 70 (in Canada – CSA Std. C22.1). Wiring diagrams are located in the control compartment area. Standard wiring schematics are also included at the back of this manual.

The proper method of connecting the power source to the terminal block is shown on page 3.

Note to Electrical Inspector: Inspection of electrical connection should be accomplished by the removal of the Control Panel. This is done by loosening the three screws located at the bottom of the door opening and remove lower trim piece. Then remove the screw at the top of the control panel and then the control panel will hinge forward.

E. OVEN ASSEMBLY

Before assembling and installing the oven, please check to make sure that all necessary parts are present. In addition to the oven itself, there will also be four legs, four feet or four casters, the vent guard, (for double sections: retaining clips & vent riser) and miscellaneous hardware. Please check the interior of all oven sections for the parts needed to assemble and install the oven(s).

Leg Attachment

- Once the oven has been removed from the carton, lay it on its left side (the side without the controls).
- Hold the leg and align with the threaded hole in the front corner of the bottom of the oven. Carefully start the bolt in the corner (avoid cross threading).
- Align the other two leg plate holes in the leg with those in the oven bottom and secure each leg using the remaining two leg bolts. Repeat this process for all legs.
- Raise the oven up on the legs.
- Add the two (2) storage shelves between the four (4) legs and secure with the bolts provided.
- Level the oven by turning the adjustable feet in or out as needed.

Caster Installation

- Casters are available as an option for both the

single and double oven sections.

- The installation of casters requires the removal of the adjustable feet from the legs. This is done by placing the bit of a large screwdriver against the lip of the foot and rapping the screwdriver to drive the foot out of the leg. The caster is then inserted fully into the opening where the foot came out and the locking nut tightened to expand the compression sleeve of the caster.

NOTE: The casters with locking brakes are best mounted on the front side of the oven for easier access.

NOTE: If you plan to use casters, a fixed restraint of the proper length must be incorporated to secure the oven to a non-movable surface to eliminate strain on the power cord. If the oven is removed from its normal position, the restraint must then be reattached when returned.

Double Sections

- Secure the short legs to the bottom of the lower section as described in previous section.
- Casters are installed by the method described for single section ovens in the previous section.
- Place the oven in the upright position and mount the top oven and secure to lower oven as shown on page 27.
- Install flue guard (if required) as shown on page 27.

F. ADJUSTMENTS ASSOCIATED WITH INSTALLATION

Each oven section and all its component parts have been tested thoroughly and inspected before the oven was shipped from the factory. However, it is sometimes necessary to further test or adjust the oven once it has been installed. Such adjustments are the responsibility of the Dealer or Installer. These types of adjustments are not considered defects, rather a normal and routine part of the proper installation of the equipment.

These adjustments include but are not limited to:

- Adjustments and recalibration of the thermostat
- Adjustment to the doors.
- Leveling.
- Tightening of fasteners.

⚠ WARNING No installation should be considered complete without proper inspection and, if necessary, any adjustments by qualified service or installation personnel.

OPERATION INSTRUCTIONS

The information in this section is intended for the use of qualified operating personnel. Qualified Operating Personnel are those individuals who have carefully read the information contained in this manual, are familiar with the function of the oven and/or have had experience with operating the equipment described. We recommend following these instructions to insure optimum performance, long life and trouble-free service from your oven.

The 5/9 Electric Convection Ovens

Convection cooking has been around from the 1960s. Its advantages are well known. It differs from conventional

cooking by the movement of heated air within the cooking cavity by means of a fan. This moving, heated air helps to strip the cool air from around the product being cooked, allowing the heat to penetrate more rapidly. The results are that your product is cooked quicker and at a lower temperature with the comparable product quality found in conventional ovens.

Please take the time to carefully read the operating instructions. They are important in the successful use of your oven.

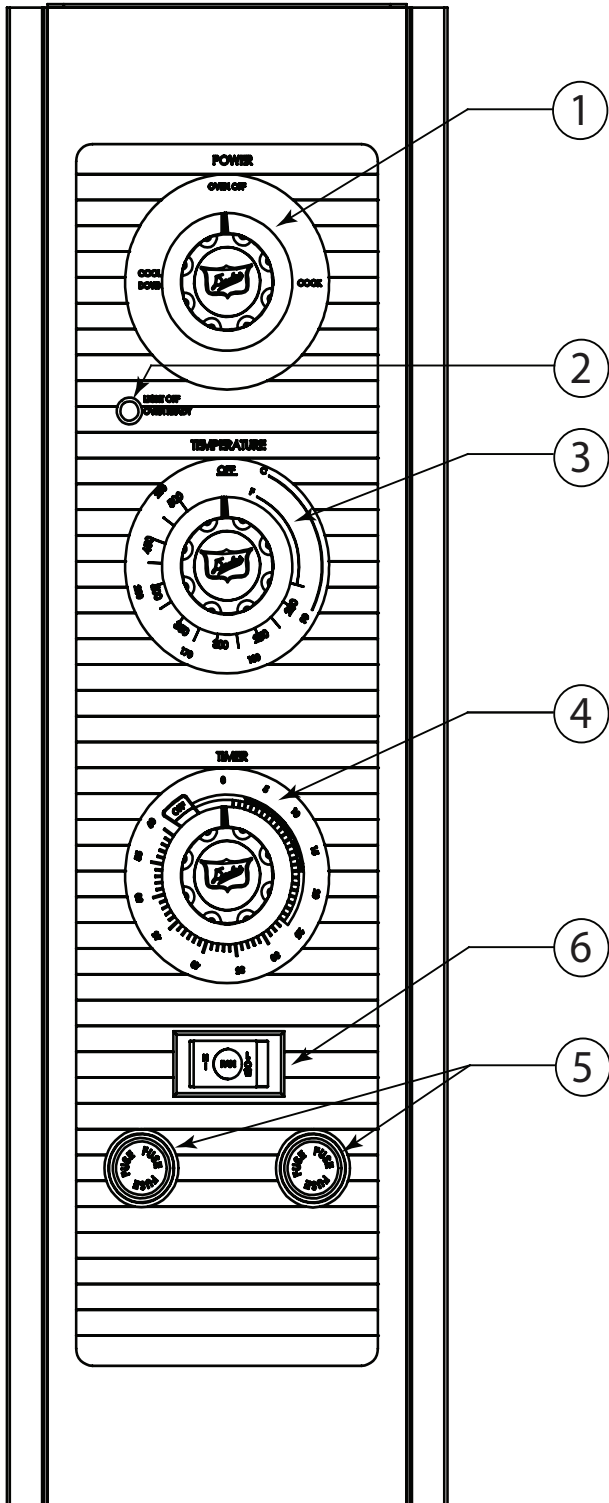

A. OVEN CONTROLS

"V" CONTROLLER

Electro-Mechanical

1. **The Power Switch** - Controls power to ON or Cool Down Function.
2. **The Indicator Light** - When lit indicates burners are operating. When the light goes out, the oven has reached its cooking temperature.
3. **The Cooking Thermostat** - Controls the oven temperature.
4. **The Cooking Timer** - Sounds an electric buzzer on expiration of operator set time as a reminder to remove product at end of cooking cycle.

NOTE: To set times of less than 25 minutes, turn timer knob past 25 minutes and then back to the desired time.

5. **The Fuse Holders** - Contain circuit protecting fuses.
6. **The Fan Speed Switch (Optional)** - Sets fan speed to high or low.

“V” Controller Operating Instructions

Timer Resolution

The Timer displays time from 0 to 60 minutes, in one-minute increments.

Temperature Scale

The Temperature Control displays the temperature in °F. The temperature range is from 150°F - 500°F, in 25°F increments.

Cool Down

This feature enables the oven to be cooled rapidly by allowing the fan to operate with the burners turned off. To activate, turn the Power Switch to the COOL position and open the oven door. When the door is opened enough to disengage the door switch, the fan will turn on. Closing the door will turn the fan off.

Fan Speed Switch

The fan speed can be set to high or low speed by placing the FAN HI/LOW button to the desired setting.

Cooking

A cooking cycle can be initiated as follows:

- Turn the Power Switch to COOK position.
- Set the Cooking Temperature by turning the TEMPERATURE dial to the desired temperature. The OVEN READY indicator light will turn on.
- When the OVEN READY indicator light turns off, place the product to be cooked in the oven.
- Set the cooking Time by turning the COOK TIMER dial to the desired time.

NOTE: To set times of less than 25 minutes, turn timer knob past 25 minutes and then back to the desired time.

During the Cook Cycle, the OVEN READY Indicator light will cycle on and off with the heating elements.

- When the COOK TIMER reaches “zero”, the alarm will sound.
- To cancel the alarm, turn the COOK TIMER dial to the OFF position.

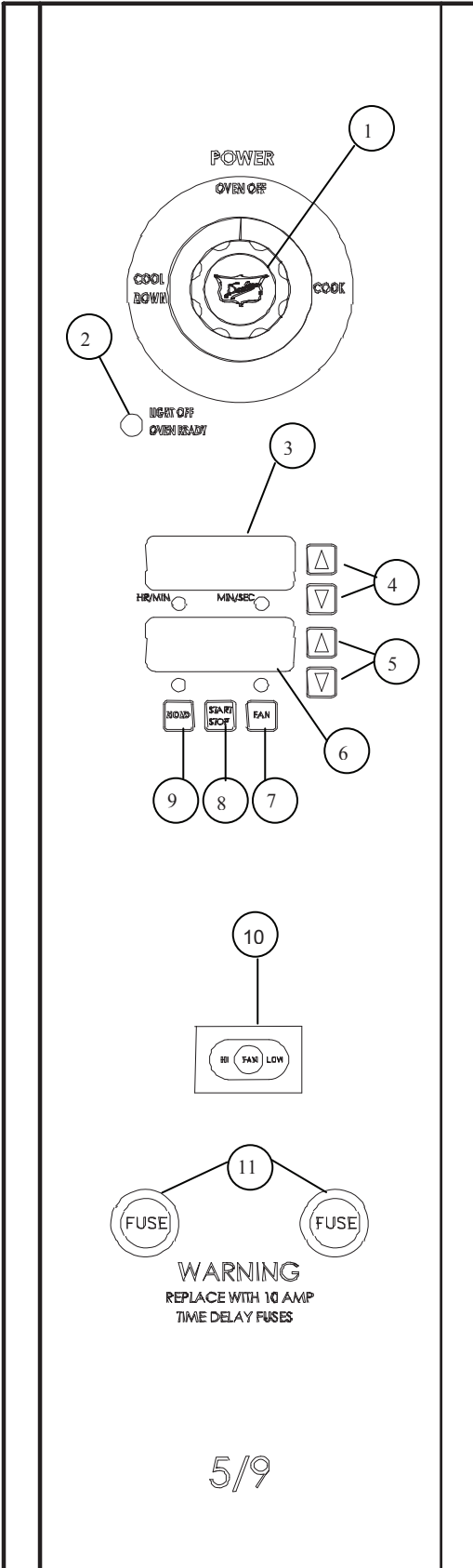

“XX” CONTROLLER

Oven Controls – Solid State Digital

1. **The Power Switch** – Controls power to Cook or Cool Down functions.
2. **The Indicator Light** – When lit indicates burners or elements are operating. When the light goes out, the oven has reached the desired temperature.
3. **The Time Digital Display** – Displays time remaining in the chosen cycle.
4. **The Time Adjustment Buttons** – Sets/Adjusts countdown timer for cook cycle.
5. **The Temperature Adjustment Buttons** – Sets/Adjusts cooking temperature.
6. **The Temperature Digital Display** – Displays the temperature inside the oven
7. **The Pulse Fan Button** – Enables/Disables the Pulse Fan Cycle.
8. **The Start/Stop Button** – Starts/Stops the cooking cycle.
9. **The Hold Button** – Enable/Disables the Hold Function.
10. **The Fan Speed Switch (Optional)** – Sets fan speed to high or low.
11. **The Fuse Holders** – Contains circuit Protecting fuses.

“XX” Controller Programming & Operating Instructions

Models with the XX controller enable the oven to cook food at a specified temperature for a specified time period, than enter an optional hold mode. The hold mode holds food at a specified temperature for a specified period of time.

When the power switch is in the ON position the oven will be in one of two modes:

- **Cook Mode:** In this mode the oven operates at a specified temperature and the fan runs continuously, unless the cycle option is selected. In cycle mode the fan runs for 30 seconds and is off for 30 seconds.

This cycle continues during the specified cook time.

- **Hold Mode:** In this mode the oven operates at a specified hold temperature; however the fan only runs when the burners are on. If the fan mode switch is in the COOL position the fan will run continuously in the Hold mode.

To Program Cook Mode do the following:

1. Turn the power switch ON. The power switch is located at the top of the Control Panel.
2. Set the desired cook temperature (150° to 500°F). Use the arrow keys located next to the temperature display. Up raises the temperature, down lowers the temperature.
3. Set the Fan Mode Switch to the Cook position. In the Cook position the fan will not run when the doors are open. If the Fan Mode Switch is set in the COOL position the fan WILL run when the doors are open.
4. If pulse fan cycling is desired press the FAN button. In this mode the fan runs for 30 seconds and is off for 30 seconds. The fan indicator light will blink when the fan is in cycle mode. It stays on steady when the fan is in continuous run mode.
5. Select the correct fan speed for the item being cooked. The Fan Speed switch has two speeds, HI, or LOW.
6. Set the desired cook time by using the up and down arrows next to the cook time display. Up increases time, down decreases time.
7. If the Hold Mode is going to be used for the product being cooked, press the HOLD button. The temperature display now displays the Hold temperature. Use the up and down arrows to set

the desired holding temperature.

8. Wait until the temperature display stops flashing, when it stops flashing the oven has reached the set temperature. The oven also beeps once to alert the user that it is ready.
9. Place product to be cooked into the oven and press the START/STOP button. The time display begins counting down the remaining cook time. If the oven doors are opened during the cook cycle, the timer will pause, the fan will shut off and the burners will shut off. Cook cycle will resume when the doors are closed. For ovens equipped with an interior light, the light may be turned on by pressing and holding the LIGHTS button at the bottom of the Control Panel. The cook time, oven temperature and fan cycle mode can be changed during the cook cycle as needed. To cancel a cook cycle, press the START/STOP button.
10. If the HOLD mode is NOT enabled the oven begins beeping and the display will flash "00" indicating the cook cycle is complete. Press the START/STOP button to silence the alarm and immediately remove the product from the oven. If the oven doors are shut the oven will maintain the set cook temperature even though the timer has run out. To cool down the product, open the doors, with the Fan Mode to COOL and change the FAN SPEED to HI. If the HOLD mode IS enabled the oven will beep three times when the cool time has completed. The timer will begin an upward count, indicating how long the product has been holding. The temperature display now displays the holding temperature. The oven will remain in HOLD mode until the START/STOP button is pressed. Pressing the START/STOP button returns the oven to the COOK mode.
11. When cooking is completed press the Power ON/OFF button to turn the oven off.

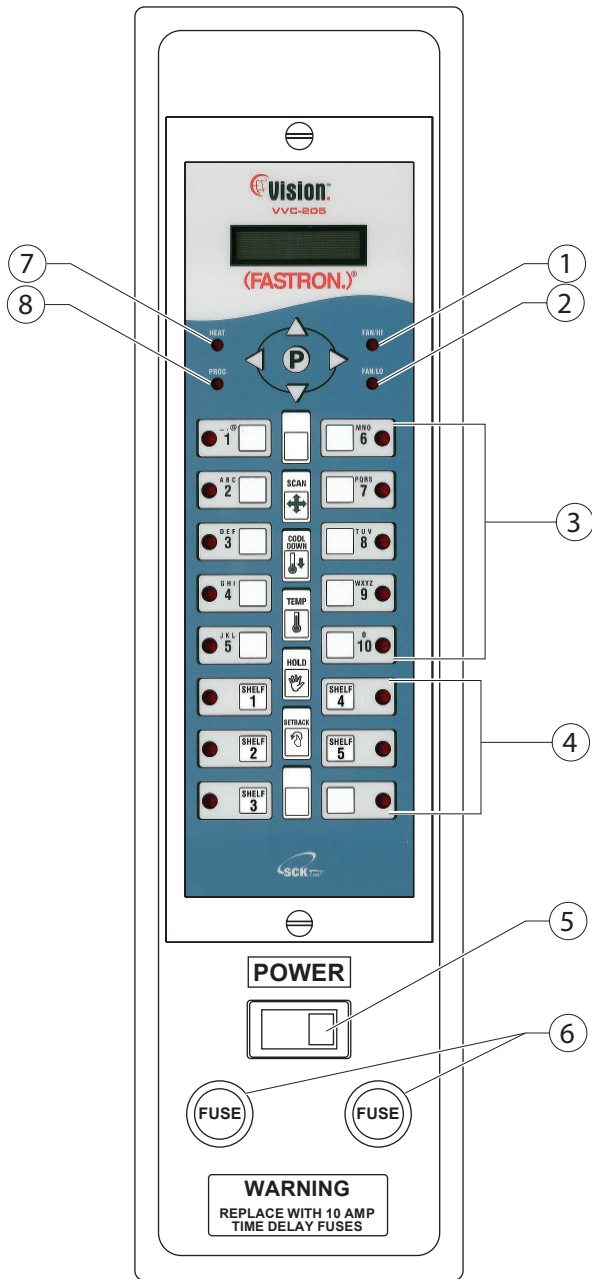

“ZZ” CONTROLLER

Oven Controls – Solid State Digital Control with Rack Timer Capability.

1. **Fan Mode High** – LED is lit when fan is in HIGH mode.
2. **Fan Mode Low** – LED is lit when the fan is in low speed mode.
3. **Product Keys** – When Product Key is selected its corresponding LED will be lit.
4. **Shelf Keys** – When a Shelf Key is selected its corresponding LED will be lit.
5. **Main Power ON/OFF Switch** – Used to turn the Oven On or Off.
6. **Ten Amp Delay Fuses** – Provide protection for oven circuits if they overheat.
7. **Convection Heat Mode** – When the oven is in convection mode the Convection Heat Mode LED will be lit.
8. **Program Mode** – When in the Program Mode the Program Mode LED will be lit.

“ZZ” Controller Programming & Operating Instructions

The (FASTRON.) “Vision Series” Convection Oven Controller is designed to simplify the cooking process and allow foodservice operators to spend more time with the customers and other important responsibilities. Quality control of the food product is assured through the various features, notification displays and alarms designed into the controller.

There are three modes of operation on the controller:

- Operating Mode: Used to cook various menu items
- Programming Mode: Used to enter cooking recipes
- System Programming Mode: Used to set oven parameters

Profile Baking

The (FASTRON.) “Vision Series” Convection Oven Controller provides one-touch control of the entire baking process by allowing you to divide each product bake cycle into ten distinct stages or “profiles”. Each stage can be programmed for time, temperature, fan

speed, controller-compensated time, or straight time countdown mode.

Using profile baking with muffins, for example, yields excellent results. Here is an example of a typical controller bake cycle for an oven load of muffins, half corn and half blueberry:

Profile 1: Begin at 400°F for 5 minutes with fan on.

Profile 2: After 5 minutes, when the muffin batter has risen to the top of the cups, program the fan off for the next 10 minutes to allow the muffins to rise high and evenly.

Profile 3: Turn the fan back on and set oven temperature to 375°F for the next 5 minutes, permitting an even bake through the center of the product.

Profile 4: During the last 5 minutes of the bake cycle, increase the temperature to 400°F to set the muffin peaks and finish them off to a golden color.

Welcome to profile baking! Please take the time now to read the Programming Instructions for the (FASTRON.) "Vision Series" Convection Oven Controller.

PROGRAMMING INSTRUCTIONS

RECIPE PROGRAMMING 1724

Entering Programming and Changing Recipes

Press and hold the "P" for 3 seconds.

PRODUCT CNT will be displayed. Press the down arrow.

PROGRAMMING will be displayed. Press the "P" key.

ENTER CODE will be displayed. Type in 1724, then press the "P" key.

RECIPE will be displayed. Press the "P" key and all product LED's will light up and the display will read SELECT PRODUCT TO PROGRAM

Press the Product key you would like to program.

ALL will be displayed. Press the "P" key.

PRODUCT NAME will be displayed. To scroll through the Library, use the arrow Up or Down keys or you can use the letters on each key to start a word from the Library. Once you have chosen your word, press the "P" key.

SHELF COOK NO will be displayed. Use the Left or Right arrow keys to select YES or NO for Shelf Cook.

Then press the "P" key.

NOTE: If YES is selected, you will not be given an option for extra stages.

STAGE X TIME will be displayed with the current set time XX:XX. To change the time, type in a new time. Then press the "P" key.

STAGE X TEMP will be displayed with the current set temp XXXF. To change the temperature, type in your new temperature. Then press the "P" key.

STAGE X TIMING will be displayed, then either STRAIGHT, FLEX or SENSITIVITY. Use the Left and Right arrow keys to change between the 3 settings. Then press the "P" key.

STAGE X SENS will be displayed with the current sensitivity setting 0-9. To change the sensitivity setting, type in your new setting. Then press the "P" key.

STAGE X FAN SPD will be displayed, then either HIGH or LOW. To change between the 2 settings, use the Left or Right arrow keys. Then press the "P" key.

STAGE X FAN CYC will be displayed, then either FULL, HEAT, or PULSE. To change between the 3 settings, use the Left and Right arrow keys. Then press the "P" key.

If PULSE is selected:

STAGE X FAN ON will be displayed with the current time XX:XX. To change the Fan ON time, type in a new time. Then press the "P" key.

STAGE X FAN OFF will be displayed with the current time XX:XX. To change the Fan OFF time, type in a new time. Then press the "P" key.

Note: Each product key can be programmed with up to 10 stages. If no additional stages are required, set the time to zero, and press the "P" key to continue to Alarm Time.

ALARM X TIME will be displayed with the current time XX:XX. To change the alarm time, type in a new time. Then press the "P" key.

ALARM X NAME will be displayed with the current name. To scroll through the Library, use the Up or Down arrow keys, or you can use the letters on each key to start a word from the Library. Once you have chosen your word, press the "P" key.

ALARM X DONE will be displayed with either

AUTOMATIC or MANUAL. To change between the 2 settings, use the Left or Right arrow keys. Then press the "P" key.

ALARM X TONE will be displayed with either SHORT, MEDIUM, LONG, DOUBLE, LONG/SHORT, or NONE. To change between the 6 settings, use the Left and Right arrow keys. Then press the "P" key.

NOTE: You can set up to 3 alarms per key. Follow the above directions if 3 alarms are needed.

HOLD TIME will be displayed with the current time XX:XX. To change the hold time, type in a new time. Then press the "P" key

HOLD TEMP will be displayed with the current hold temperature XXXF. To change, type in a new temperature. Then press the "P" key.

HOLD DONE will be displayed with either AUTOMATIC or MANUAL. To change between the 2 settings, use the Left or Right arrow keys. Then press the "P" key.

HOLD FAN SPEED will be displayed then either HIGH or LOW. To change between the 2 settings, use the Left or Right arrow keys. Then press the "P" key.

PRODUCT HEADS will be displayed with the current head count setting 0-99. To change, type in a new setting. Then press the "P" key.

To Exit Recipe Programming

From ALL being displayed, scroll up to EXIT and press the "P" key. RECIPE will be displayed. Scroll down to EXIT and press the "P" key.

SYSTEM PROGRAMMING 3228

Entering System Programming And Changing System Settings

Press and hold the "P" for 3 seconds.

PRODUCT CNT will be displayed. Press the Down arrow key.

PROGRAMMING will be displayed. Press the "P" key.

ENTER CODE will be displayed. Type in 3228. Then press the "P" key.

SYSTEM will be displayed. Press the "P" key.

APPLIANCE TYPE will be displayed, then either ELECTRIC FULL, ELECTRIC HALF, GAS HALF, GAS FULL. To change between the 4 settings, use the Left and Right arrow keys. Then press the "P" key.

LANGUAGE will be displayed then either ENGLISH or OTHER. To change between the 2 settings, use the Left or Right arrow keys. Then press the "P" key.

TONE VOLUME will be displayed then either 1-4 or NONE. To change between the 5 settings, use the Left and Right arrow keys. Then press the "P" key.

TEMPERATURE will be displayed, then either F or C. To change between the 2 settings, use the Left or Right arrow keys. Then press the "P" key.

HOLD TIME will be displayed with the current time XX:XX. To change the hold time, type in a new time. Then press the "P" key

HOLD TEMP will be displayed with the current hold temp XXXF. To change the hold temp, type in a new temperature. Then press the "P" key.

HOLD DONE will be displayed with either AUTOMATIC or MANUAL. To change between the 2 settings, use the Left or Right arrow keys. Then press the "P" key.

HOLD FAN SPEED will be displayed, then either HIGH or LOW. To change between the 2 settings, use the Left or Right arrow keys. Then press the "P" key.

SETBACK TIME will be displayed, then XX:XX. To change the Setback time, type in a new time. Then press the "P" key

SETBACK TEMP will be displayed with the current setback temp XXXF. To change the setback temperature, type in a new temperature. Then press the "P" key.

PREHEAT TIME will be displayed then XX:XX. To

change the preheat time, type in a new time. Then press the “P” key.

To Exit System Programming

SYSTEM will be displayed. Press the Up arrow key and EXIT will be displayed. Then Press the “P” key.

FACTORY PROGRAMMING 3228

Entering Factory Programming And Changing Factory Settings

Press and hold the “P” for 3 seconds.

PRODUCT CNT will be displayed. Press the Down arrow.

PROGRAMMING will be displayed. Press the “P” key.

ENTER CODE will be displayed. Type in 3228. Then press the “P” key.

Display will show SYSTEM.

Press the down arrow key to FACTORY. Then Press the “P” key.

MAX PROG TEMP will be displayed, then either 550F or 500F. To change between the 2 settings, use the Left or Right arrow keys. Then press the “P” key.

FAN SPEED TYPE will be displayed, then either 1 SPEED or 2 SPEED. To change between the

2 settings, use the Left or Right arrow keys. Then press the “P” key.

If you change the default setting, the controller will prompt “Are you sure? Existing recipe fan speed will be reset!) Choose YES or NO. Then press the “P” key.

To Exit Factory Programming

FACTORY will be displayed. Press the Up arrow key 2 times to EXIT. Then press the “P” key.

PROGRAMMING will be displayed. Press the down arrow key and EXIT will be displayed. Press the “P” key.

ADDING PRODUCT AND PRE-ALARM NAMES, PASS CODE #3228

Programming a Custom Product and Pre-alarm name

Press and hold the “P” for 3 seconds.

PRODUCT CNT will be displayed. Press the down arrow key.

PROGRAMMING will be displayed. Press the “P” key.

ENTER CODE will be displayed. Type in 3328, then press the “P” key.

SYSTEM will be displayed. Press the down arrow key until either PRODNAME LIB or ALARM LIB is displayed.

Press the “P” key and a flashing dash will be displayed.

Press the SCAN key and use the number keys to spell the new word using the arrow right key to go to the position of the word. Once the word is spelled press the “P” key and SAVE LIBRARY ADD will be displayed.

If you press the “P” key again, the word you spelled will be saved. If you do not want the word, or need to modify it, press the left or right arrow key to CANCEL or MODIFY and press the “P” key.

Note: To delete the word and start over, press the TOGGLE/CLEAR key.

To Exit Library Mode

Either PRODNAME LIB or ALARM LIB will be displayed. Press the arrow up or down key until the display reads EXIT. Press the “P” key.

Exit Factory Programming

FACTORY will be displayed. Press the arrow up key 2 times and EXIT will be displayed. Press the “P” key.

B. GENERAL GUIDELINES FOR OPERATION

These guidelines are to assist you in obtaining the best performance from your oven:

- Always pre-heat your oven before cooking by placing the temperature setting at the desired temperature. The oven is pre-heated when the Indicator Light goes out.
- Always use a lower temperature setting than that recommended for a standard conventional oven or range oven. The general rule of thumb is to subtract 50 - 100°F from the standard oven recipe. Some experimentation on your part may be necessary to achieve the optimum results with your food products.

NOTE: Cooking at higher temperatures will not reduce your cooking time! It will produce unsatisfactory baking and roasting results.

- You should begin checking the doneness of your food product in about half the time recommended for the same recipe cooked in a standard oven. There is a Suggested Time and Temperature Chart on the next page, which can serve as a guide. Keep in mind that your times may vary depending on the amount of product being cooked in your oven. The best results are always achieved when a systematic record of times and temperatures is kept for reference.
- The oven will hold up to thirteen 18" x 26" (457mm x 660mm) sheet pans. Your product and pan height will determine how many racks can be loaded.

NOTE: Do not place an empty sheet pan or aluminum foil on the bottom of the oven. This will disrupt the airflow and cause uneven cooking results.

- To minimize the shrinkage of roasted meats, place the meat directly on the racks and place a sheet pan one half full of water in the bottom rack position. The water will keep the oven compartment more humid and the meat juices will evaporate less.
- Maintain equal loads when cooking more than one pan of product at a time. You may wish to weigh the product to assure that the pan loads are equal. Smaller loads in one pan will cook at a different rate than larger ones in another.

- You may wish to experiment with leaving the oven OFF after pre-heating the oven and loading when baking light products such as light cake batter or custard so the product will have time to set. Normally, 7-10 minutes with the oven OFF, then finishing with the oven ON, will keep the product from rippling or being pushed by the fan.
- When starting off with frozen product, you may wish to pre-heat your oven up to 100° F above the temperature you are going to cook. Load the product and reset the temperature for the normal time.
- For longer bulb life, do not leave the oven lights on when not viewing the product.

C. SUGGESTED TIMES & TEMPERATURES

	PRODUCT	°F	°C	COOK TIME	RACKS	TEMP	TIME
BEEF	HAMBURGER PATTIES (3.3 OZ)	400	205	8 – 10 MIN	13		
	MEAT LOAF	325	165	40 -45 MINE	4		
	STEAMSHIP ROUND (80 LBS QUART)	275	135	2 ¼ HOURS	2		
	ROLLED BEEF ROAST (12 – 15 LBS)	275	135	2 ½ HOURS	4		
	STANDING RIB ROAST (20 LBS RARE)	235	115	2 ¾ HOURS	2		
	SHELL STEAKS (10 OZ)	450	230	7 – 8 MIN.	6		
	POT PIES	400	205	30 – 35 MIN.	6		
	STUFFED PEPPERS	350	175	15 – 20 MIN.	4		
	LASAGNA	260	175	90 MIN	4		
	HOT DOGS	325	165	10 – 15 MIN	6		
PORK	BAKED STUFFED PORK CHOPS	375	190	25 – 30 MIN	6		
	BACON	400	205	5 – 7 MIN	13		
VEAL	BONED VEAL ROAST (15 LBS)	300	150	3 HRS 10 MIN	3		
LAMB	LAMB CHOPS	400	205	7 – 8 MIN	6		
POULTRY	CHICKEN BREASTS AND THIGHS	350	175	40 MIN	6		
	CHICKEN BACKS AND WINGS	350	175	35 MIN	6		
	CHICKEN QUARTERED	350	175	30 MIN	6		
	TURKEY ROLL (18 LBS)	310	155	30 – 35 MIN	6		
FISH	FISH STICKS	335	170	16 – 18 MIN	13		
SEAFOOD	COD, HALIBUT (FROZEN)	350	175	20 MIN	6		
	SHRIMP, BAKED STUFFED	400	205	6 – 7 MIN	6		
	LOBSTER, BAKED STUFFED	400	205	10 MIN	4		
	LOBSTER TAILS (FROZEN)	425	220	9 MIN	6		
CHEESE	MACARONI & CHEESE CASSEROLE	350	175	30 MIN	6		
	GRILLED CHEESE SANDWICHES	400	205	8 MIN	13		
POTATOES	BAKED POTATOES	400	205	50 MIN	6		
	SLICED OR DICED POTATOES	325	165	10 MIN	6		
	FRENCH FRIES (FROZEN)	TIMES AND TEMPS WILL VARY AS TO CUT.					
PIES	FROZEN BERRY PIES (22 TO 36 OZ EA)	325	165	35 MIN	6		
	FROZEN FRUIT PIES (24 TO 46 OZ EA)	325	165	45 – 50 MIN	6		
	FRESH APPLE PIE (20 TO 36 OZ EA)	350	175	25 – 30 MIN	6		
	PUMPKIN PIE	300	150	30 – 50 MIN	6		
	FRUIT CRISP	300	150	25 MIN	6		
	FRUIT COBBLER	300	150	30 MIN	6		
	APPLE TURNOVERS	350	175	15 MIN	6		
	BREADS	BREAD (32 – 1 LB LOAVES)	325	165	30 MIN	4	
NORTHERN CORN BREAD		325	165	25 MIN	6		
SOUTHERN CORN BREAD		375	190	15 – 20 MIN	6		
HAMBURGER ROLLS		275	125	15 MIN	6		
YEAST ROLLS		300	150	25 MIN	6		
CAKES	BISCUITS	400	205	6 MIN	6		
	ROLLS, BROWN & SERVE	350	175	15 MIN	6		
	SHEET CAKE (5 LBS BATTER PER PAN)	325	165	16 – 18 MIN	6		
COOKIES	CHOCOLATE CAKE	325	165	29 MIN	6		
	BROWNIES	325	165	15 MIN	6		
	DANISH PASTRY	325	165	12 MIN	6		
	CINNAMON BUNS	325	165	20 MIN	6		
	SUGAR COOKIES	275	125	15 MIN	13		
	CREAM PUFFS	325	165	20 – 25 MIN	6		
	CHOCOLATE CHIP COOKIES	325	165	10 MIN	13		
	PEANUT BUTTER COOKIES	300	150	10 MIN	13		

NOTE: Your times and temperatures may vary from those shown on this chart. Your results depend on weight per pan, temperature of the product before loading, the recipe, type of pan, and calibration of the thermostat. If your recipes vary from these, write in your proven times and temperatures for your future use.

D. COOK & HOLD/ROAST & HOLD RECOMMENDED TIME & TEMPERATURE

PRODUCT	QTY	COOK TEMP	HOLD TEMP	COOK TIME	HOLD TIME MINIMUM	TOTAL TIME
PRIME RIB BONE IN CAP OFF	1	200°F	140°F	3 HRS	1 HR	4 HR
14 – 18 LBS (6.4 – 8.1 KG)	3	93°C	60°C	3-1/4 HRS	1-1/2 HRS	4-3/4 HRS
	6			3-1/2 HRS	2 HRS	5-1/2 HRS
PRIME RIB BONE IN CAP ON	1	200°F	140°F	3-1/2 HRS	1 HR	4-1/2 HRS
18 – 22 LBS (8.1 – 10 KG)	3	93°C	60°C	4 HRS	1-1/2 HRS	5-1/2 HRS
	6			4-1/2 HRS	2 HRS	6-1/2 HRS
TOP OR BOTTOM ROUNDS	1	200°F	140°F	3-1/2 HRS	1 HR	4-1/2 HRS
10 – 12 LBS (4.5 – 5.4 KG)	3	93°C	60°C	4 HRS	1-1/2 HRS	5-1/2 HRS
	6			4-1/2 HRS	2 HRS	6-1/2 HRS
PORK ROAST OR HAM CAP OFF	1	250°F	170°F	4 HRS	1 HR	5 HR
10 – 12 LBS (4.5 – 5.4 KG)	3	121°C	76°C	4-1/4 HRS	1-1/2 HRS	5-3/4 HRS
	6			4-1/2 HRS	2 HRS	6-1/2 HRS
TURKEY 20 - 22 LBS (6.4 – 8.1 KG)	1	250°F	170°F	3-3/4 HRS	1 HR	4-3/4 HR
	2	121°C	76°C	4 HRS	1-1/2 HRS	5-1/2 HRS
LEG OF LAMB BONE IN	2	225°F	160°F	2-1/2 HRS	1 HR	3-1/2 HR
	4			2-3/4 HRS	1-1/2 HRS	4-1/4 HRS
8 - 10 LBS	6	107°C	71°C	3 HRS	2 HRS	5 HRS

COOK & HOLD - ROAST & HOLD

Control Options with COOK & HOLD - ROAST & HOLD feature include conveniences not found in standard control ovens. This feature is particularly valuable when roasting meats. By using the slower speed “Roast - Lo Fan” for the primary cooking cycle and setting a lower temperature (140°F or higher is recommended) for the hold cycle, your meats can be cooked and then held for up to 16 hours. The lower temperatures used and the slower fan speeds reduce shrinkage, thus increasing yields. Also, meats roasted in this manner over longer periods tend to be more tender and juicy.

An added benefit of using your 5/9 to Roast & Hold is lower energy costs.

COOK & HOLD - ROAST & HOLD cooking is a three step process.

- COOK or ROAST - This step is controlled by the count down timer and the temperature controller. Meat is roasted at a lower temperature for a longer period of time. Meats are generally cooked until

about 2/3 done in this cycle. At the end of the roasting cycle, the controls automatically shift to the “HOLD” mode.

- STORED HEAT COOKING - This is a natural change in temperature and is not a controlled function; i.e., there are no times or temperatures to set. It is a portion of the “HOLD” cycle as far as timing. In this step the oven temperature slowly drops down to the “HOLD” temperature setting. This step may take 1 -2 hours. It is important that meats being cooked by this method be left in the “HOLD” cycle for at least two hours as they continue to cook.
- HOLD - Once the meat reaches the holding temperature, it can be held up to sixteen hours prior to serving. The blower at low speed will cycle on and off to maintain the “HOLD” temperature you set into the temperature controller.

NOTE: The “COOK - HI-FAN” cycle can be substituted for the “ROAST-LO-FAN” cycle with the only change being the velocity of the fan being higher.

E. GENERAL GUIDELINES FOR COOK & HOLD - ROAST & HOLD

- Always allow the meat to remain in the "HOLD" cycle for a minimum of two hours. This will assure that the stored heat of the "COOK - ROAST" cycle has brought it to the desired degree of doneness.
- Always thaw meats in a refrigerator and temper the meat 30-45 minutes at room temperature before cooking. Cooking frozen food products is not recommended, as it will increase the "COOK -ROAST" cycle and increase shrinkage.
- Aged meat cooks more rapidly and this should be taken into consideration when establishing cooking times

MAINTENANCE INSTRUCTIONS

These maintenance instructions are for the use of qualified service personnel only. Service by other than qualified personnel may result in damage to the oven and/or injury to the operator.

Qualified service personnel are those individuals, firms, companies or corporations which either in person or through an agent are engaged in and responsible for repair or servicing of commercial food preparation equipment, who are experienced in such work, familiar with all precautions required, and have complied with all requirements of state and local authorities having jurisdiction.

If you should require assistance in the selection of a qualified service agency, please contact Duke Manufacturing Co.'s Service Department at 800-735-3853.

A. ADJUSTMENTS

Quite often malfunctions, which are attributed to defects, may be repaired by adjusting certain parts rather than replacing them.

B. DOOR SWITCH ADJUSTMENT

You may also wish to adjust the door switch. The door switch is located behind the combustion compartment cover, on the right side. The door switch is activated by a cam, which is mounted to the door's hinge pin with a setscrew.

1. Open the door fully.
2. Remove the lower cover by loosening the three screws located inside the door opening.
3. Position the door so it is nearly closed but not latched.
4. To adjust the cam loosen the setscrew and rotate the cam until you hear the switch click.
5. Tighten the setscrew in the cam. Test the door to make certain the switch will make contact with the doors closed.
6. Torque setscrew to 60 in-lbs.
7. Replace the cover.

⚠ WARNING The door switch is located in a heated zone. Care should be taken to avoid burns.

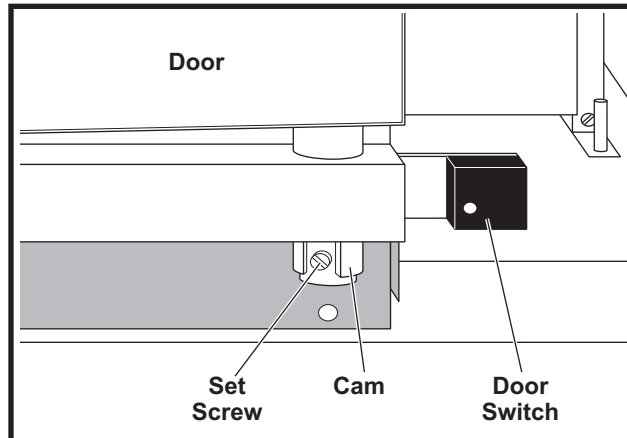

C. THERMOSTAT CALIBRATION

Electro-Mechanical Controls Only ("Q" & "V"). Not applicable to Ovens with Solid State Controls.

In many convection ovens thermostats have been the cause of more operating problems than any other component part. Thermostats, being mechanical devices, do sometimes fail, in which case only replacing the part will correct the problem. However, the great majority of thermostat related problems could be attributed to their being out of adjustment (calibration). A thermostat that is out of calibration may cause unsatisfactory cooking results such as uneven baking, prolonged cooking times, etc. If you are experiencing uneven cooking, it may be a result of excessive cooking temperatures. Refer to the cooking chart provided in Operating Instructions Section C.

To Check Calibration:

- Turn the oven on by turning the Power Switch to the ON position.
- Open the doors and place a thermocouple in the center of the middle oven rack. A reliable mercury-type thermometer can be substituted if a pyrometer is not available.
- Turn the thermostat dial to 350°F (177°C). Allow the oven to preheat 1/2 hour.
- When the indicator light goes out, the thermostat has been satisfied. Check the pyrometer or thermometer to determine the internal oven temperature.
- If the reading on the pyrometer (or thermometer) is less

than 10°F different from the setting of the thermostat, no adjustment is needed. If this reading is more than 10°F, proceed with calibration procedure.

To Calibrate the Ovens

- Remove the thermostat knob by loosening the setscrew and pull the knob forward. Take care not to rotate the thermostat stem, which will change the setting.
- With a very small screwdriver, turn the screw located in the bottom of the hollow of the stem clockwise to lower the temperature or counterclockwise to raise the temperature. DO NOT allow the stem of the thermostat to rotate as you turn the screw.
- Open the door and turn the POWER SWITCH to the COOL DOWN position. This will allow the oven fan to come on without the burners and cool off the oven. Allow the oven to cool to about 250°F (120°C).
- Return the POWER SWITCH to the ON position and repeat the previous steps until the oven thermostat and the pyrometer (thermometer) reading agree.
- Replace the knob and tighten the setscrews.

NOTE: Maximum turn of screw “A” is 1-1/2 turns – clockwise or counter-clockwise.

This thermostat is a direct-acting (opens on temperature rise) device.

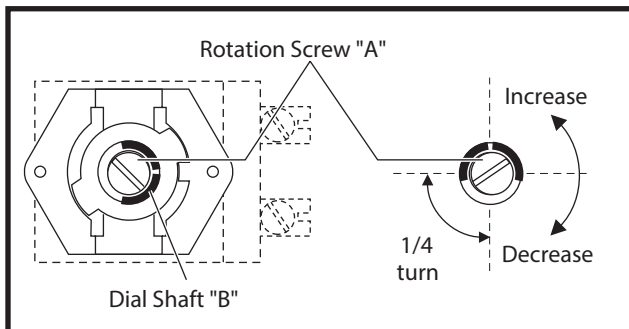

Porcelain oven interiors should be cleaned regularly using a degreasing agent. For heavier deposits a commercial oven cleaner such as Dow Oven Cleaner, Easy-Off, or Mr. Muscle can be used. Care must be taken to prevent these alkaline-type cleaners from coming in contact with any aluminized steel surfaces in the oven, including the blower wheel.

The blower wheel, racks and rack supports can be removed and soaked in a solution of ammonia and water.

Make certain that all parts are thoroughly rinsed before returning to use.

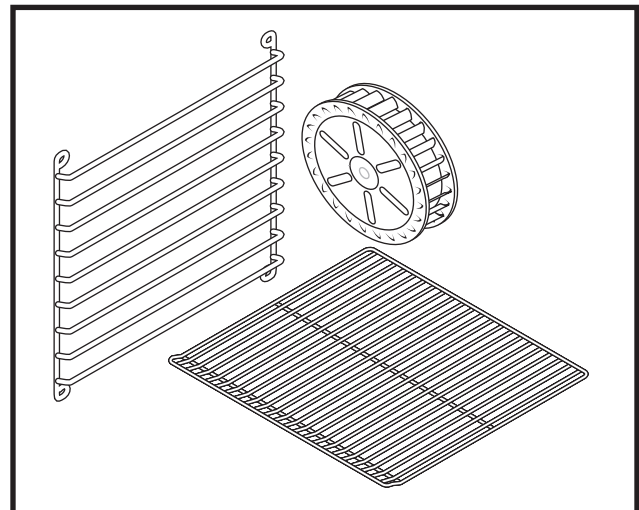

D. CLEANING OF THE OVENS

The stainless steel on your oven can be kept clean with a good stainless steel cleaner, many of which are on the market. The painted surfaces should be wiped clean regularly with a MILD detergent. Moisten a cloth and wipe down the oven while it is COLD. Wiping down an oven while it is hot will cause streaking and otherwise unsatisfactory results. Once the oven is clean it can be wiped down with light oil.

5/9 DOOR ASSEMBLY (TYPICAL)

5/9 DOOR ASSEMBLY (TYPICAL)
LEFT HAND HINGED SHOWN

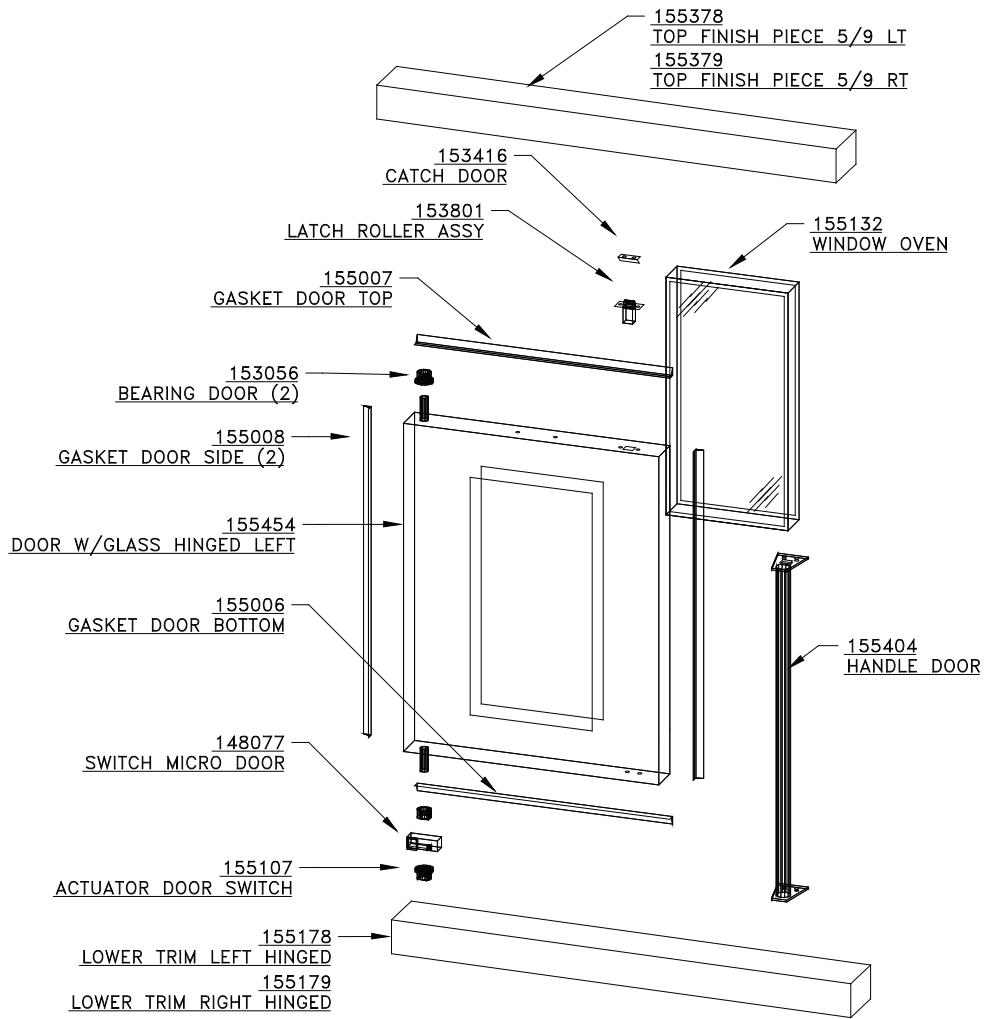

5/9 "V" CONTROLLER ASSEMBLY

MODEL 59-V OVEN CONTROLS

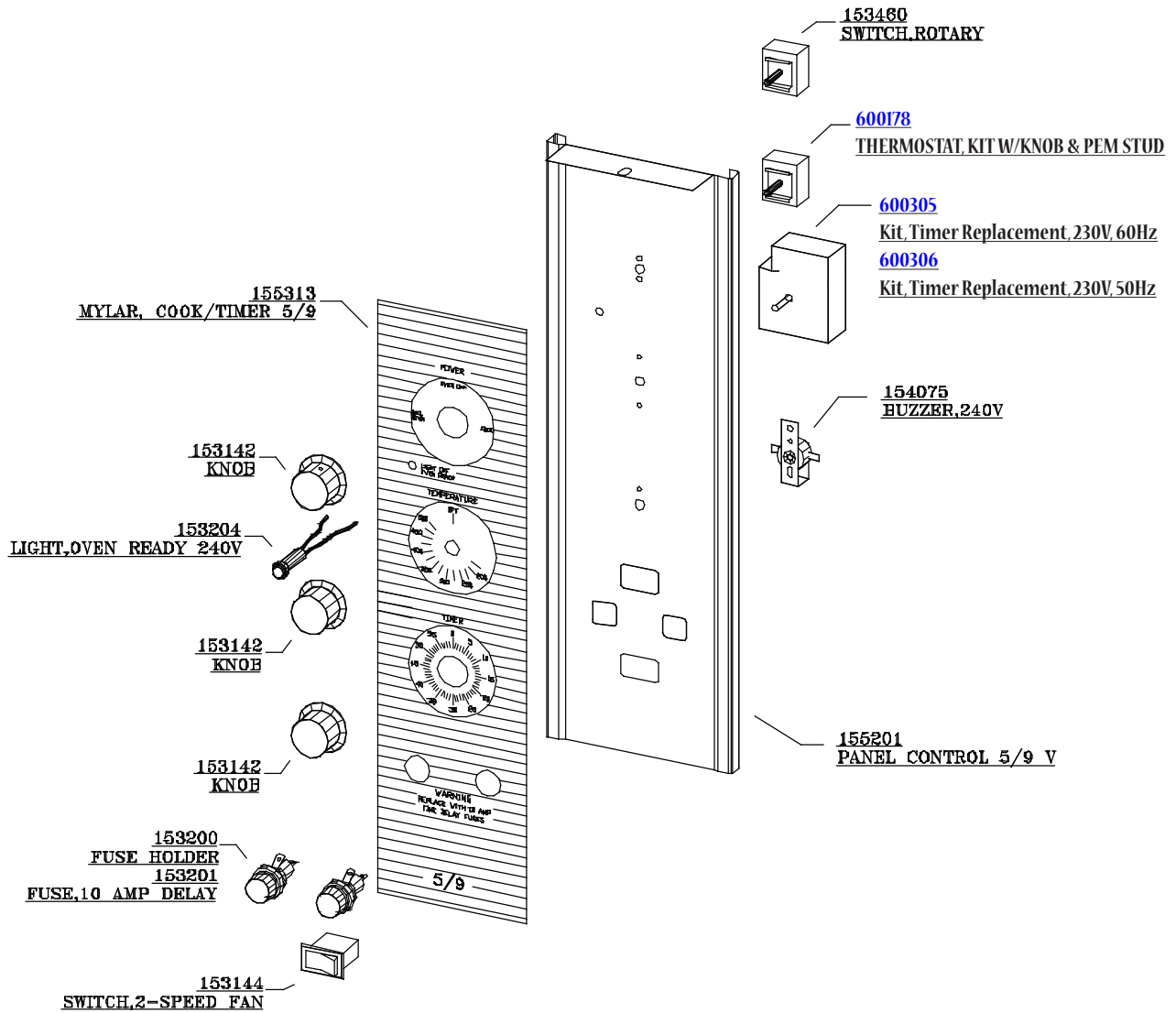

5/9 "XX" CONTROLLER ASSEMBLY

MODEL 59-XX OVEN CONTROLS

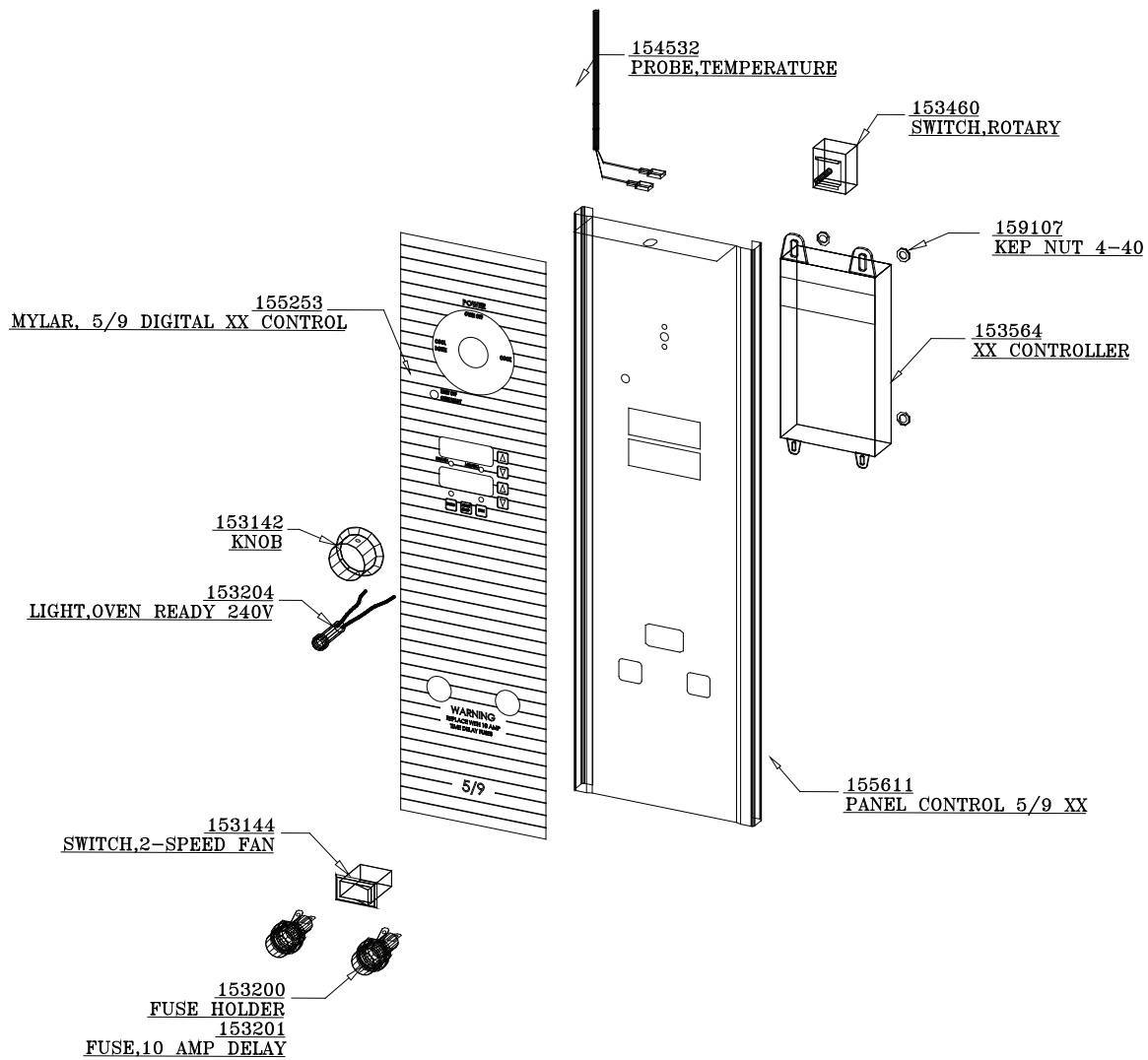

5/9 "ZZ" CONTROLLER ASSEMBLY

MODEL 59-ZZ OVEN CONTROLS

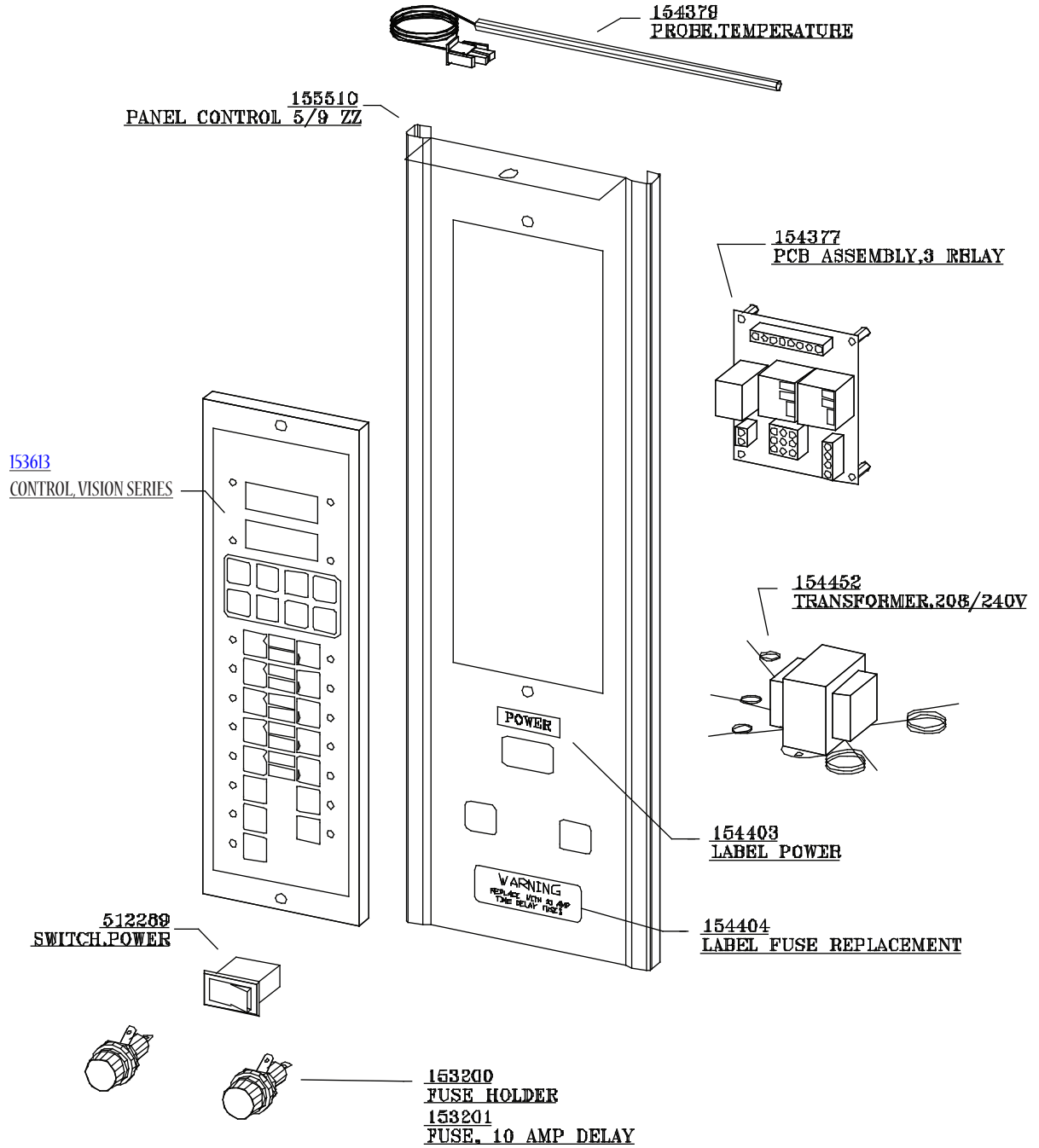

CONTACTOR IDENTIFICATION

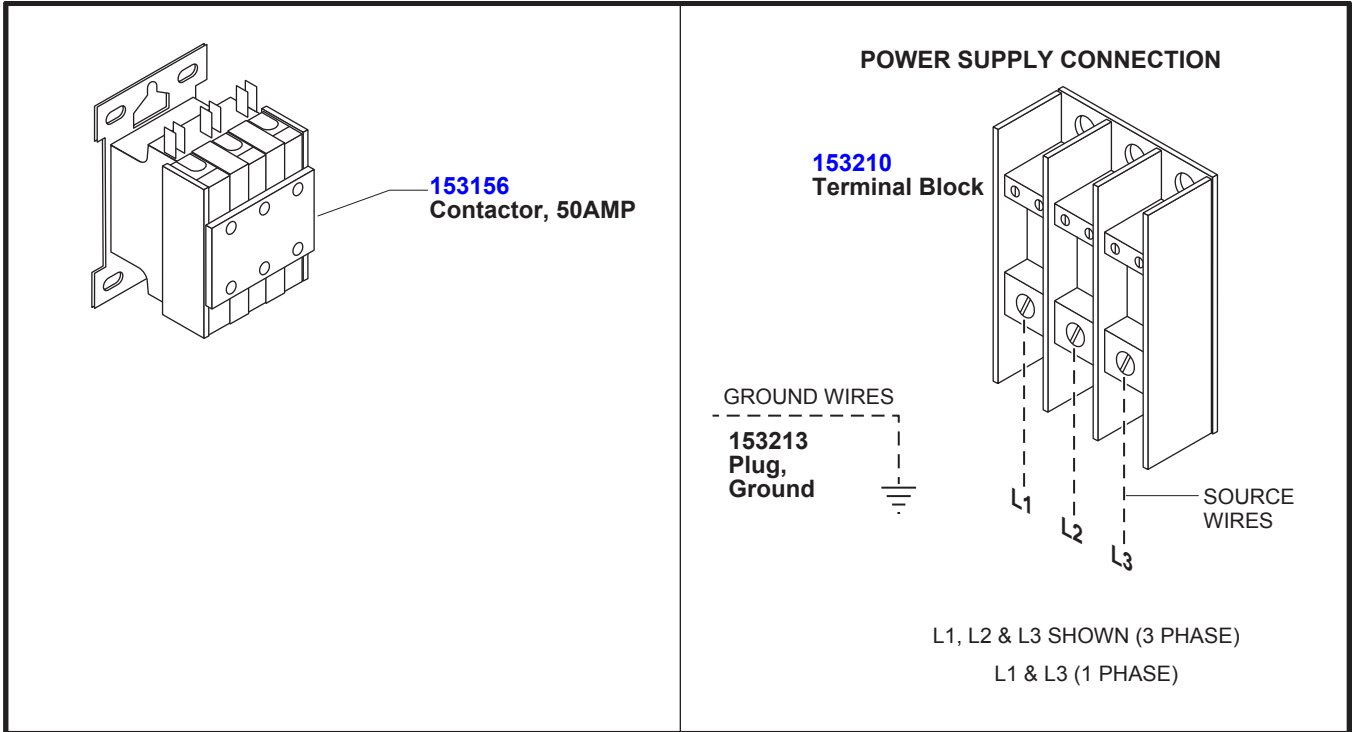

FLUE GUARD INSTALLATION

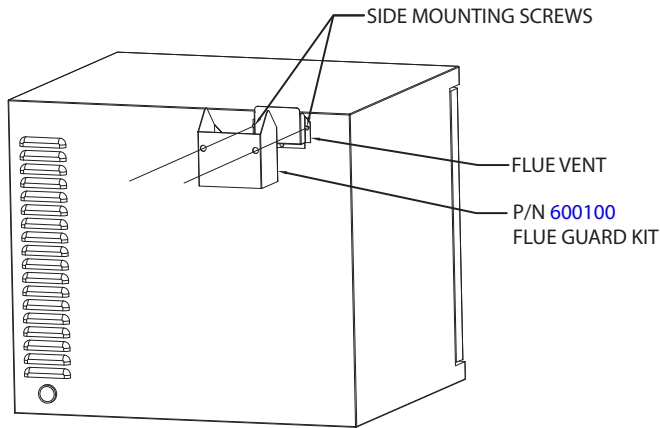

- 1.) Partially back-out the two side mounting screws of the flue vent.
- 2.) Slide the keyhole slots of the flue guard over the partially backed-out screws and then down.
- 3.) Tighten the two screws.

SECURING DOUBLE STACKED OVENS

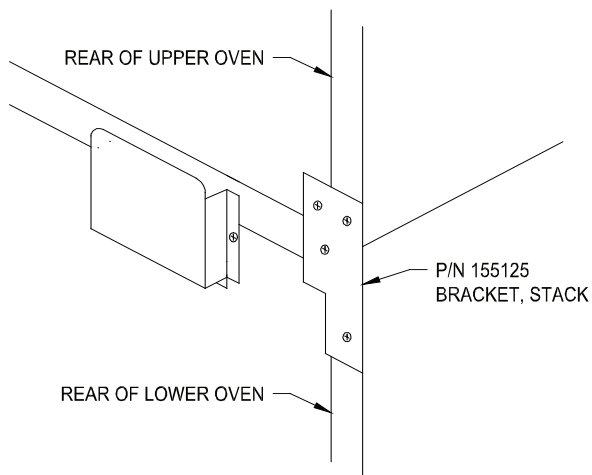

SECURING 5/9
DOUBLE STACKED OVENS

- 1.) On rear of the top oven remove two existing screws that are located at the lower right hand corner.
- 2.) On rear of bottom oven remove two existing screws that are located at the upper right hand corner.
- 3.) Install stacking bracket using the existing screws as shown in figure.
- 4.) Repeat steps to install 2nd stacking bracket on left hand side.

“V” CONTROLLER WIRING SCHEMATIC

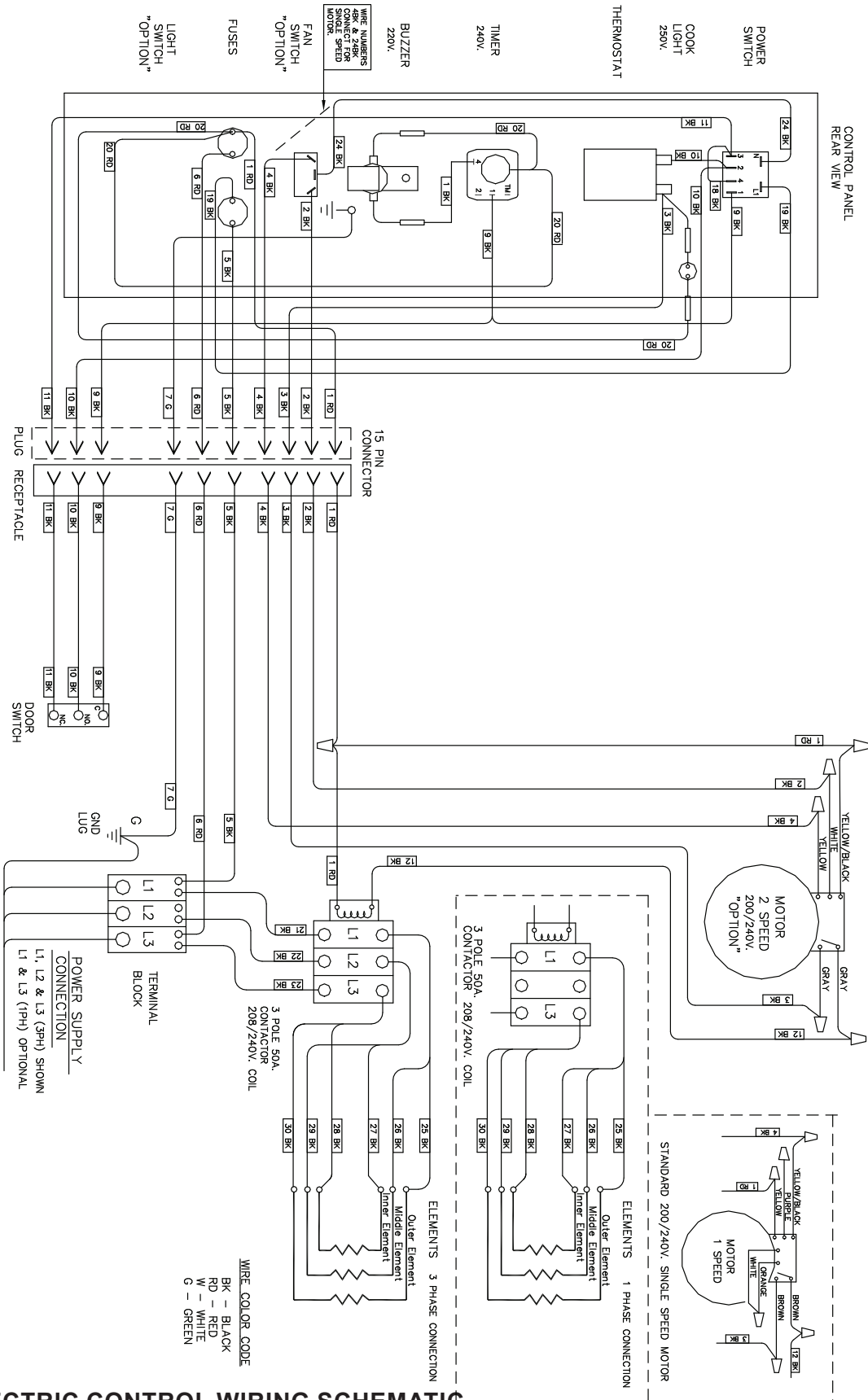

“XX” ELECTRIC CONTROL WIRING SCHEMATIC

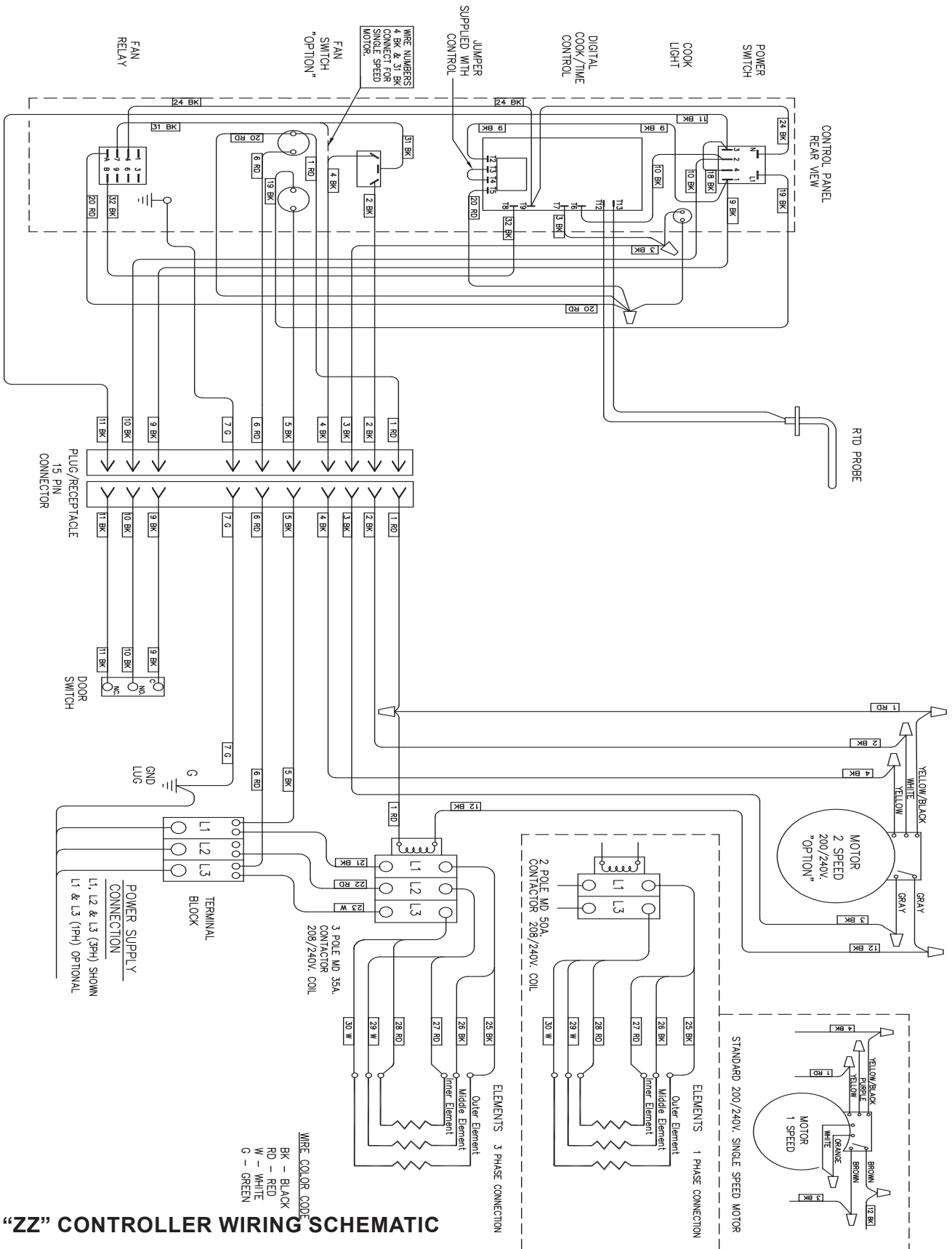

“ZZ” CONTROLLER WIRING SCHEMATIC

CONTROL PANEL
REAR VIEW

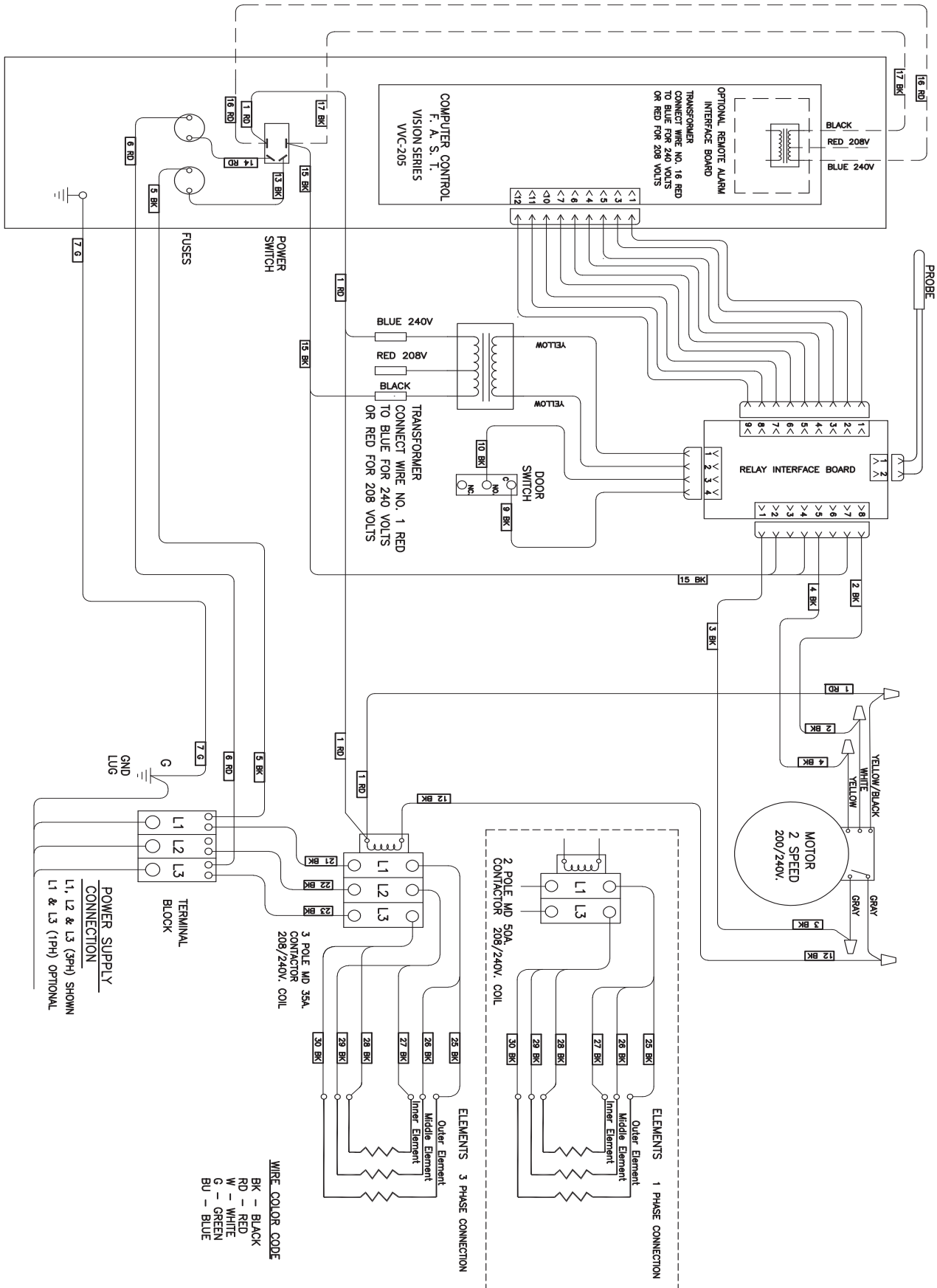

CUSTOMER ASSISTANCE

To aid in reporting this unit in case of loss or theft, please record below the model number and serial number located on the unit. We also suggest you record all the information listed and retain for future reference.

MODEL NUMBER:	SERIAL NUMBER:
DATE OF PURCHASE:	
DEALER:	TELEPHONE:
SERVICER:	TELEPHONE:

FOR WARRANTY, PARTS & SERVICE:

**DUKE CORPORATE,
CANADA, LATIN AMERICA**

2305 N. Broadway
St. Louis, MO 63102
Phone: 314-231-1130
Toll Free: 800-735-3853
Fax: 314-231-2460
service-dispatch@dukemfg.com

DUKE ASIA PACIFIC

Duke Manufacturing
No.3 Building
Lane 28, Yu Lv Road
Malu Town, Jiading District
Shanghai 201801, China
Phone: +86 21 59153525 / 59153526
Fax: +86 21 33600628

**DUKE EMEA - EUROPE, MIDDLE
EAST, AFRICA, RUSSIA**

Duke Manufacturing CR, s.r.o.
Zdebradska 92
Jazlovice, Ricany
Building number DC 4 on the
ProLogis Park Prague D1 West
Prague 251 01
Czech Republic
Phone: +420 257 741 033
Fax: +420 257 741 039
service.prague@duke-emea.com

**DUKE EMEA – UK, IRELAND, NORDIC
COUNTRIES**

Duke Manufacturing UK Ltd.
Unit 10, Greendale Business Park
Woodbury Salterton
Exeter, EX5 1EW
Phone: +44 (0) 1395 234140
Fax: +44 (0) 1395 234154
service.exeter@duke-emea.com

TO ACCESS INTERNET: www.dukemfg.com

Please provide the following information when you write or call: model number, serial number, date of purchase, your complete mailing address (including zip code), and description of the problem.



Your Solutions Partner

Duke Manufacturing Co.

2305 N. Broadway
St. Louis, MO 63102
Phone: 314-231-1130
Toll Free: 1-800-735-3853
Fax: 314-231-5074

www.dukemfg.com