6/13 THE OVEN

ELECTRIC CONVECTION OVEN



*Installation, Operation, Parts
& Maintenance Manual*



"Your Solutions Partner"

DUKE MANUFACTURING CO.
2305 N. Broadway • St. Louis, MO 63102
800.735.3853 • 314.231.1130 • 314.231.5074 Fax
www.dukemfg.com

152469P

INDEX

	PAGE
6/13 Electric Specifications	3
Installation Instructions	
A. Qualified Personnel	4
B. Delivery & Inspection	4
C. Location of Oven	4
D. Electrical Connections	4-5
E. Oven Assembly	5
F. Adjustments Associated with Installation	5
Operating Instructions	
A. Oven Controls	6-30
B. General Guidelines for Operation	31
C. Suggested Times & Temperatures	32
D. Cook & Hold – Roast & Hold	33
Maintenance Instructions	
A. Adjustments	34
B. Door Adjustment	34
C. Door Switch Adjustment	34
D. Thermostat Calibration	34-35
E. Cleaning the Oven	35
Repair Parts List	36
Door Assembly	38
Double Stack Ovens	39
“V” Controller Assembly	40
“X” Controller Assembly	41
“Z” Controller Assembly	42
“ZX” Controller Assembly	43
“XX” Controller Assembly	44
Contactor Identification	45
Wiring Diagrams	46-55

**Please supply the ID Number and the Serial Number when ordering
replacement parts or requesting service.**

**We recommend service by Duke Authorized Service Agencies during
and after the warranty period.**

POST IN A PROMINENT LOCATION instructions to be followed in the event the user smells gas. This information shall be obtained by consulting the local gas supplier.

FOR YOUR SAFETY:

Do not store gasoline or other flammable vapors or liquids in the vicinity of this or any other appliance.

WARNING:

Improper installation, adjustment, alteration, service or maintenance can cause property damage, injury or death. Read the installation, operating and maintenance instructions thoroughly before installing or servicing this equipment.

6/13 CONVECTION OVEN

Electrical Specifications

TOTAL KW	VOLTS	1 PHASE	3 PHASE
10 KW	208	53	31
10 KW	240	46	27
10 KW	220/380		20
10 KW	240/415		18
10 KW	480		14

INSTALLATION INSTRUCTIONS:

A. Qualified Personnel

These installation instructions are for the use of qualified installation and service personnel only. Installation or service by other than qualified personnel may result in damage to the oven and/or injury to the operator.

Qualified installation personnel are those individuals, firms, companies or corporations which either in person or through an agent is engaged in and responsible for:

- The installation of electrical wiring from the electric meter, main control box or service outlet to the electrical appliance. Qualified installation personnel must be familiar with all precautions required and have complied with all requirements of state and local authorities having jurisdiction. See: National Electrical Code, ANSI/NFPA70.

B. Delivery and Inspection

Duke Manufacturing Co. does everything within its power to insure you received your oven in good condition. They are strapped down on heavy wooden skids and surrounded by heavy "tri-wall" cartons to prevent shipping damage. They have all been carefully inspected before they were packaged and consigned to the carrier.

Upon delivery of your Duke oven:

- Look over the shipping container, carefully noting any exterior damage on the delivery receipt, which must also be signed by the driver/delivery person.
- Uncrate and check for any damage, which was not evident on the outside of the shipping container. This is called concealed damage. The carrier must be notified within fifteen (15) days of the delivery of the oven and the carton, skid and all packaging materials must be retained for inspection.

Duke Manufacturing Co. cannot assume liability for loss or damage suffered in transit. The carrier assumes full responsibility for delivery in good order when the shipment was accepted. However, we are prepared to assist you in filing your claim.

C. Location of the Oven

Proper planning and placement of the oven will give you the best results in terms of long-term user

convenience and satisfactory performance. We urge you to give adequate thought in the placement of your oven prior to its arrival.

- The oven should be placed in an area that is free from drafts and accessible for proper operation and servicing.
- The area around the oven must be kept clear of combustible materials. A minimum clearance of:

	Combustible	Non-Combustible
RIGHT SIDE	1"	0"
LEFT SIDE	1"	0"
REAR	3"	3"
FLOOR	8"	8"

Must be maintained between the oven and any combustible or non-combustible surface.

It is also important not to obstruct the natural flow of ventilation air if the oven is to operate properly. This oven should not be installed on a curb base or sealed to the wall. Either condition can restrict the flow of air to or prevent proper ventilation of the blower motor. The blower motor has a thermal protection device, which will trip, because of excessive ambient temperatures at the back of the oven. This condition should be corrected immediately to avoid damaging the oven permanently.

Before making any connections to the oven, check the rating plates to be sure the oven specifications concur with the voltage and phase to be supplied to the oven.

The rating plate is located behind the lower front panel. To access, loosen the four screws below the doors, and pull the panel outward.

The plate bearing the oven's serial number is attached to the underside of the upper ledge above the control panel.

D. Electrical Connections

Your oven is supplied for connection to a 208, 240, 440 or 480 volt grounded circuit. The electric motor, oven lights, indicator lights and control circuits are connected internally and require no secondary power supply.

Before making any connections to these units, check the rating plate to assure that the voltage and phase of the oven is compatible with the electrical supply. When installing, all ovens must be electrically grounded in accordance with local codes or in the absence of local codes, with the National Electrical Code, ANSI/NFPA 70 (in Canada – CSA Std. C22.1). Wiring diagrams are located in the control compartment area. Standard wiring schematics are also included at the back of this manual.

Note to Electrical Inspector:

Inspection of electrical connection should be accomplished by the removal of the lower finishing piece. This is done by loosening the four screws located in the door opening under the doors.

E. Oven Assembly

Before assembling and installing the oven, please check to make sure that all necessary parts are present. In addition to the oven itself, there will also be legs, feet or casters, the vent guard, (for double sections, retaining clips, vent riser) and miscellaneous hardware. Please check the interior of all oven sections for the parts needed to assemble and install your oven(s).

Leg Attachment

- Once the oven has been removed from the carton, lay it on its lift side (the side without the controls).
- Hold the leg and align with the threaded hole in the front corner of the bottom of the oven. Carefully start the bolt in the corner (avoid cross threading).
- Align the other two leg plate holes in the leg with those in the oven bottom and secure each leg using the remaining two leg bolts. Repeat this process for all legs.
- Raise the oven up on the legs.

Level the oven by turning the adjustable feet in or out as needed.

Caster Installation

- Casters are available as an option for both the single and double oven sections.
- The installation of casters requires the removal of the adjustable feet from the legs. This is done by placing the bit of a large screwdriver against the lip of the foot and rapping the screwdriver to drive the foot out of the leg. The caster is then inserted fully into the opening where the foot came out and the locking nut tightened to expand the compression sleeve of the caster.

NOTE: The casters with locking brakes are best mounted on the front side of the oven for easier access.

NOTE: If you plan to use casters and flexible fuel gas connectors, a fixed restraint of the proper length must be incorporated to secure the oven to a non-movable surface to eliminate strain on the connector. If the oven is removed from its normal position, the restraint must then be reattached when returned.

Double Sections

- Secure the short legs to the bottom of the lower section as described in previous section.
- Casters are installed by the method described for single section ovens. Previous section.
- Place upper section on top of lower section and align all edges of the ovens.
- Locate securing clips and align with holes on rear frames of oven section, install three screws each as provided and tighten.
- At the rear of the oven, install the flue connector by sliding it up through the flue vent opening in the top of the oven and over the upper flue vent. Push it flush with the back of the oven then slide it down over the lower flue vent. Attach with screws provided.
- Install flue guard or draft hood adapter and draft hood & draft hood collar to upper section.

F. Adjustments Associated with Installation

Each oven section and all its component parts have been tested thoroughly and inspected before your oven was shipped from the factory. However, it is sometimes necessary to further test or adjust the oven once it has been installed. Such adjustments are the responsibility of the Dealer or Installer. These types of adjustments are not considered defects, rather a normal and routine part of the proper installation of the equipment.

These adjustments include but are not limited to:

- Adjustments and recalibration of the thermostat
- Adjustment to the doors.
- Leveling.
- Tightening of fasteners.

No installation should be considered complete without proper inspection and, if necessary, any adjustments by qualified service or installation personnel.

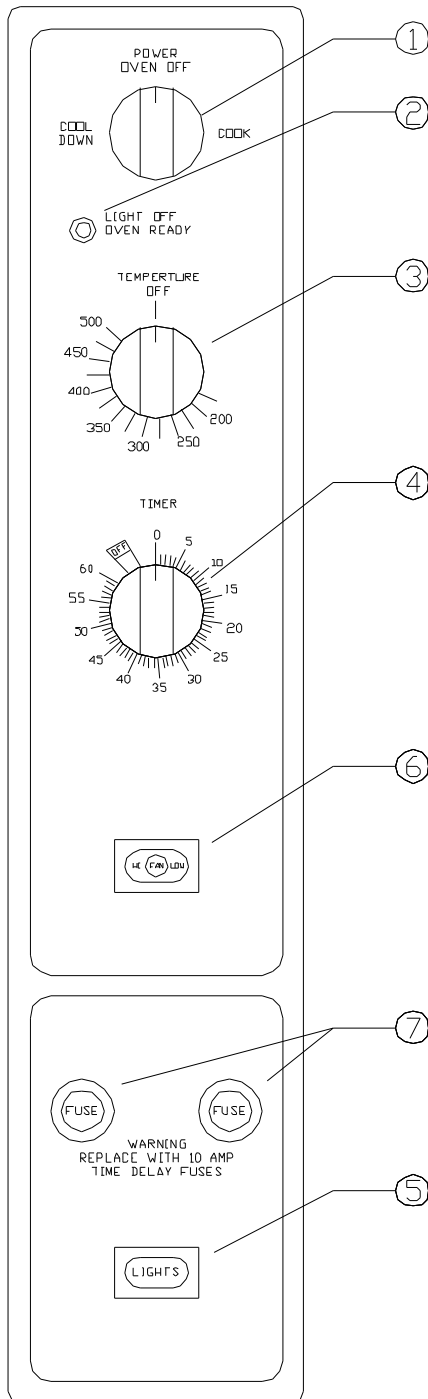

“V” Controller

A. Oven Controls - Electro-Mechanical

- **1. The Power Switch** - Controls power to ON or Cool Down Function.
- **2. The Indicator Light** - When lit indicates burners are operating. When the light goes out, the oven has reached its cooking temperature.
- **3. The Cooking Thermostat** - Controls the oven temperature.
- **4. The Cooking Timer** - Sounds an electric buzzer on expiration of operator set time as a reminder to remove product at end of cooking cycle.
- **5. The Light Switch** (Optional) - Controls interior lights.
- **6. The Fan Speed Switch** (Optional) - Sets fan speed to high or low.
- **7. The Fuse Holders** – Contain circuit protecting fuses.

Operating Instructions - “V” Controller

Timer Resolution

The Timer displays time from 0 to 60 minutes, in one-minute increments.

Temperature Scale

The Temperature Control displays the temperature in °F. The temperature range is from 150°F - 500°F, in 25°F increments.

Cool Down

This feature enables the oven to be cooled rapidly by allowing the fan to operate with the heating elements turned off. To activate, turn the Power Switch to the COOL position and open the oven door. When the door is opened enough to disengage the door switch, the fan will turn on. Closing the door will turn the fan off.

Fan Speed Switch

The fan speed can be set to high or low speed by placing the FAN HI/LOW button to the desired setting.

Cooking

A cooking cycle can be initiated as follows:

- Turn the Power Switch to COOK position.
- Set the Cooking Temperature by turning the TEMPERATURE dial to the desired temperature. The OVEN READY indicator light will turn on.
- When the OVEN READY indicator light turns off, place the product to be cooked in the oven.
- Set the cooking Time by turning the COOK TIMER dial to the desired time.

During the Cook Cycle, The OVEN READY Indicator light will cycle on and off with the heating elements.

- When the COOK TIMER reaches “zero”, the alarm will sound.
- To cancel the alarm, turn the COOK TIMER dial to the OFF position.

“X” Controller

Oven Controls – Solid State Digital Controls

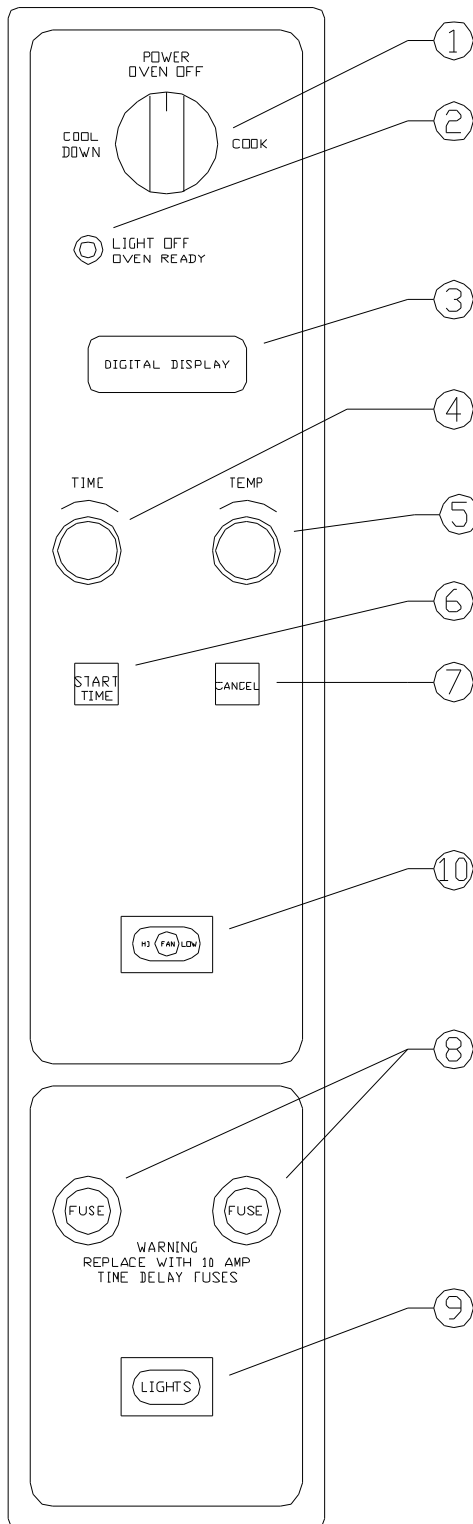

- 1. **The Power Switch** – Controls power to ON or Cool Down function.
- 2. **The Indicator Light** – When lit indicates burners are operating. When the light goes out, the oven has reached its cooking temperature.
- 3. **The Digital Display** – Indicates time and/or temperature.
- 4. **The Time dial** – Sets countdown timer for cook cycle.
- 5. **The Temperature Dial** – Sets cooking temperature.
- 6. **The Start Time Button** – Initiates timing cycle.
- 7. **The Cancel Button** – Cancels preset time and/or temperature.
- 8. **The Fuse Holders** – Contain circuit protecting fuses.
- 9. **The Light Switch** (Optional) – Controls interior lights.
- 10. **The Fan Speed Switch** (Optional) – Sets fan speed to high or low.

PROGRAMMING & OPERATION

INSTRUCTIONS FOR “X” CONTROLLER

Timer Resolution

The Timer displays time in two (2) different scales. From 0 to 60 minutes, the timer is displayed in Minutes/Seconds (“MN” Mode). From 1 to 12 hours, the time is displayed in Hours/Minutes (“HR” Mode). The mode indicators are located in the first number digit to the left of the colon.

Temperature Scale

The controller can be set to display toe temperature in °F or °C as follows:

- Turn Power Switch to COOK position.
- Set TIME to 00:00 and TEMP so “20” is displayed in the right two temperature digits.
- Press and hold both the START TIME and CANCEL buttons for 5 seconds. The control will display “CCC” and “FFF” in the temperature digits to indicate it has entered the mode.
- Turn the TIME or TEMP dial to toggle between “CCC” and “FFF”.
- Press CANCEL to exit.

Power Input Frequency

The controller can be set to operate on 50Hz or 60Hz as follows:

- Turn Power Switch to COOK position.
- Set TIME to 00:00 and TEMP so “40” is displayed in the right two temperature digits.
- Press and hold both the START TIME and CANCEL buttons for 5 seconds. The control will display “50” and “60” to indicate it has entered the mode.
- Turn the TIME or TEMP dial to toggle between “50” and “60”.
- Press CANCEL to exit.

Actual Temperature Button

The actual temperature can be viewed by pressing and holding the START TIME button for approximately 2 seconds. The temperature will be displayed in the temperature digits. This can be viewed anytime the oven is in operation, except when the oven is in the HOLD mode.

Pulse

The controller can be set to operate the fan continuously, or cycle on and off every 30 seconds during the COOK cycle as follows:

- Turn Power Switch to COOK position.
- Set TIME to 00:00 and TEMP to 000.
- Press and hold both the START TIME and CANCEL buttons for 5 seconds. The control will display “Con” or “CYC” to indicate it has entered the mode.
- Turn the TIME and TEMP dial to toggle between “Con:” and “CYC”.
- Press CANCEL to exit.

The fan cannot be set to cycle if the HOLD mode is to be used.

Fan Speed Switch

The fan speed can be set to high or low speed by placing FAN HI/LOW switch to the desired setting.

The display does not indicate which mode the fan is operating.

Cool Down

This feature enables the oven to be cooled rapidly by allowing the fan to operate with the burners turned off. To activate, turn the Power Switch to the COOL position and open the oven door. When the door is opened enough to disengage the door switch, the fan will turn on. Closing the door will turn the fan off.

Cooking

A cooking cycle can be initiated as follows:

- Turn Power Switch to COOK position.
- Set the cooking time by turning the TIME dial until the desired time is shown on the display.
- Set the desired cooking temperature by turning the TEMP dial until the desired temperature is shown on the display. The indicator light will turn on and the display will flash when a minimum temperature of 150°F is entered. The flashing display indicates that the oven is in its Preheating Mode. It will no longer flash once the oven reaches the temperature set point. The indicator light will cycle on and off with the burners.
- Press the START TIME button to begin the timed cooking cycle. Pressing the CANCEL button will “zero” the timer at any time.

Cook & Hold

The controller can be set to hold the oven at a set temperature at the end of the cooking cycle as follows:

- Turn Power Switch to COOK position.
- Set TIME to 00:00 and TEMP so “50” is displayed in the right two temperature digits.
- Press and hold both the START TIME and CANCEL buttons for 5 seconds. The control will display “HOLD” in the time digits, and the current Hold Set Temperature in the temperature digits to indicate it has entered the mode.
- Turn the TIME or TEMP dial to set the desired temperature. Setting it to “000” will turn the Hold mode off.
- Press CANCEL to exit.

When the timer counts down to zero, the alarm will sound for 5 seconds and “HOLD” will appear in the display with the current hold temperature. The timer will not count up. Manual timing is required.

Offset

To compensate for the difference in temperature from the sensing element to the center of the oven the

control can be programmed with an offset. The offset is adjustable in 1°F increments up to a maximum of ±49°F.

Note: a negative offset will have the effect of raising the cavity temperature. (Example: an oven set at 375°F is determined to run at a 350 °F internal oven temperature. By programming in a -25°F offset the oven will run at a 375°F internal oven temperature.)

The offset is programmed as follows:

- Turn Power Switch to COOK position.
- Set TIME to 00:00 and TEMP so “10” is displayed in the right two temperature digits.
- Press and hold both the START TIME and CANCEL buttons for 5 seconds. The control will display “UPO” in the time digits, and the current Offset in the temperature digits to indicate it has entered the mode.
- Turn the TIME or TEMP dial to raise or lower the offset.
- Press CANCEL to exit.

“XX” Controller

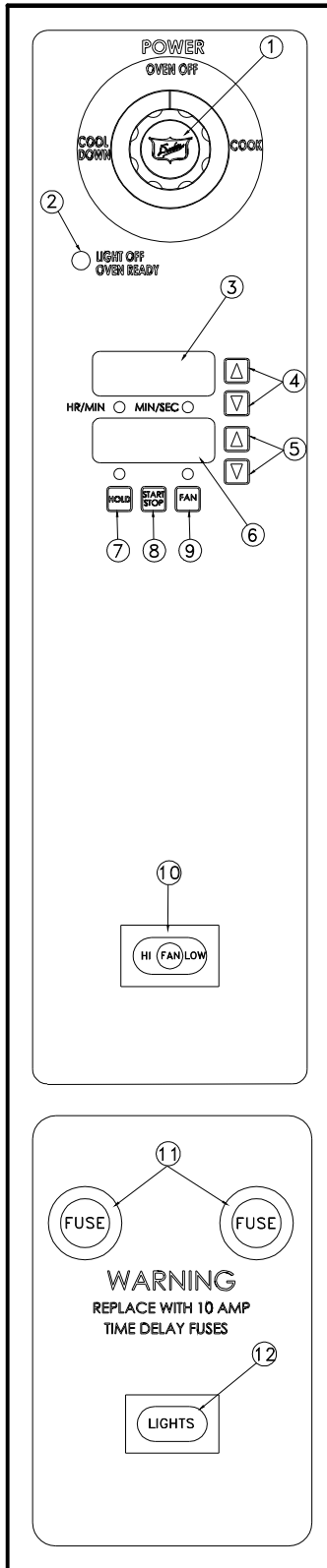

“XX” Controller – Oven Controls – Solid State Digital

- 1) The Power Switch: Controls power to Cook or Cool Down functions.
- 2) The Indicator Light: When lit indicates burners or elements are operating. When the light goes out, the oven has reached the desired temperature.
- 3) The Time Digital display: Displays time remaining in the chosen cycle.
- 4) The Time Adjustment Buttons: Sets/Adjusts cooking temperature.
- 5) The Temperature Adjustment Buttons: Sets/Adjusts cooking temperature.
- 6) The Temperature Digital Display: Displays the temperature inside the oven.
- 7) The Pulse Fan Button: Enable/Disables the Pulse Fan Function.
- 8) The Start/Stop Button: Starts/Stops the cooking cycle.
- 9) The Hold Button: Enables/Disables the Hold Function.
- 10) The Fan speed Switch: (Optional) – Sets fan speed to high or low.
- 11) The Fuse Holders: Each holds a 10 AMP Time Delay fuse.
- 12) The Light Switch: Turns interior lights on/off.

Programming and Operating Instructions – “XX” Controller

Timer Scale: The Timer displays in two (2) different scales. From 0 to 60 minutes, the timer is displayed in Minutes/Seconds. This is indicated by the MIN/SEC light on the controller. From 1 to 12 hours, the time is displayed in Hours/Minutes, indicated by the HOUR/MIN light on the controller. When the oven is first turned on, the display will show the last cook time programmed.

Timer Adjustment: To increase the cook time, press the top (▲) button located next to the Time Display. To decrease the cook time, press the bottom button (▼) located next to the Time Display.

Temperature Scale: The controller can be set to display the temperature in °F or °C as follows:

- 1) Remove/move control panel so that you have access to the back of the control board.
- 2) Locate the blue jumper at connection J3.
- 3) For °F operation the jumper is not needed. Place the jumper on one of the pins for future use.
- 4) For °C operation place the jumper across the two pins of J3. When the oven is first turned on, the display will show the last cook temperature programmed. You can view the actual temperature of the oven by pressing both of the Temperature adjustment buttons of the same time

“Z” Controller

Oven Controls – Solid State Digital Controls

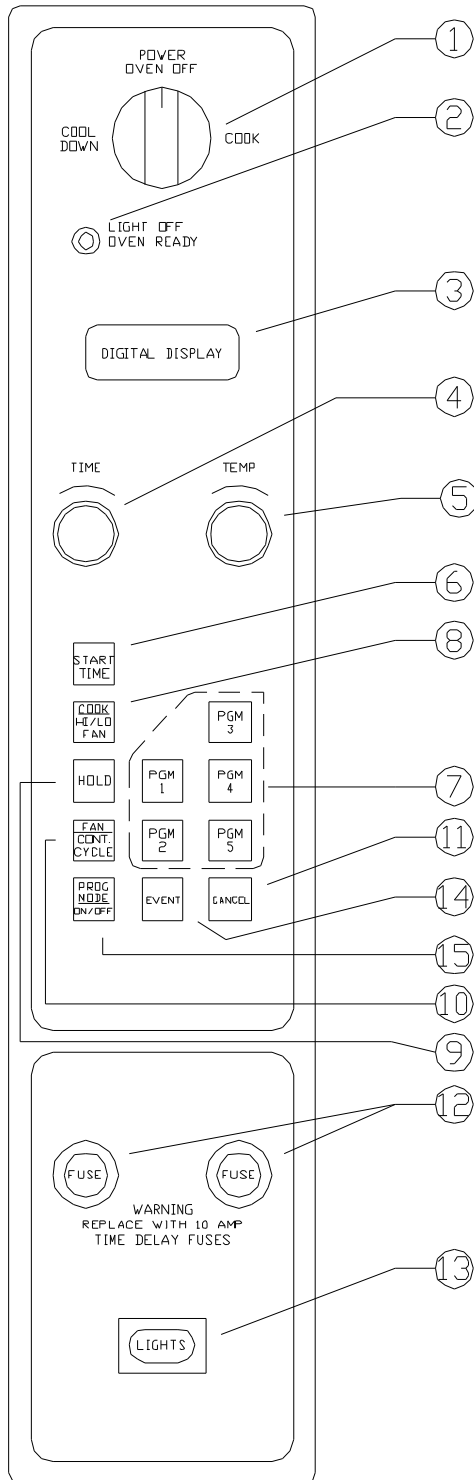

- 1. **The Power Switch** – Controls power to ON or Cool Down function.
- 2. **The Indicator Light** – When lit indicates burners are operating. When the light goes out, the oven has reached its cooking temperature.
- 3. **The Digital Display** – Indicates time and/or temperature.
- 4. **The Time Dial** – Sets countdown timer for cook cycle.
- 5. **The Temperature Dial** – Sets cooking temperature.
- 6. **The Start Time Button** – Initiates timing cycle.
- 7. **The Program Button** – 5 individual time and temperature programs. Operator programmed.
- 8. **The Cook/Hi-LO Button** – Sets fan speed to high or low.
- 9. **The Hold Button** – Allows setting of hold time and temperature.
- 10. **The Fan Continuous/Cycle Button** – Allows setting of fan to run continuously or turn on and off with the burners during the cooking cycle.
- 11. **The Cancel Button** – Cancels preset time and/or temperature.
- 12. **The Fuse Holders** – Contain circuit protecting fuses..
- 13. **The Light Switch** (Optional) – Controls interior lights.
- 14. **The Event Button** – Used for programming oven functions that will be chained into one cooking routine.
- 15. **The Program Mode – ON/OFF** – Switches from Operating to Programming Mode and back.

“Z” CONTROLLER -

PROGRAMMING & OPERATING INSTRUCTIONS

This controller provides five (5) automatic cooking chains, which the user can program. It will also a low non-automatic cooking and cook & hold operations. The fan motor can be controlled to cycle on and off with the burners or run continuously. High or low fan speeds can be selected.

The cooking chains are particularly useful when the user is producing batches of the same product time after time, especially if changes to temperature or fan speed are required during the cooking cycle. The user can program one of the five program buttons for a particular product and simply press one button when it is loaded into the oven. The control will follow the programmed cooking routine changing temperate and/or fan speeds or fan cycle/continuous at the programmed intervals. Thus, once the cooking chain is programmed, the user would benefit from consistent results when cooking the same batch.

However, not all usage of the oven requires an automatic cooking routine. In these cases, the oven can be used in a normal manner where the times and temperatures are set using the rotary dials. A manual Cook & Hold is also available for holding a product after it has been cooked.

The following instructions will assist you in using this control with your oven, but if you have any questions you should contact the Duke Service Department on our toll free support line: **800.735.3853**.

Timer Resolution

The Timer displays time in two different scales. From 0 to 60 minutes, the time is displayed in Minutes/Seconds (“MN” Mode). From 1 to 12 hours, the time is displayed in Hours/Minutes (“HR” Mode). The mode indicators are located in the first number digit to the left of the colon.

Power Input Frequency

The controller will automatically set itself to operate on 50Hz or 60Hz, depending on the power source used. All timers and internal

clocks are automatically compensated.

Temperature Scale

The controller can be set to display the temperature in °F or °C. as follows:

- Turn Power Switch to COOK position.
- Set TIME to 00:00 and TEMP so “20” is displayed in the right two temperature digits.

Press and hold the START TIME button for 5 seconds. The control will display “CCC” or “FFF” in the temperature digits to indicate it has entered the mode.

Entering will toggle between “CCC” and “FFF”. Pressing and holding the START TIME button again will also toggle the setting.

Turn Power Switch to OFF position to exit.

Time Dial

The TIME dial sets time intervals for cooking. It is used in either programmed or manual cooking.

Temp Dial

The TEMP dial sets the temperature. The temperature changes in 5°F or 1°C increments.

Start Time Button

The START TIME button initiates the cooking cycle whether a programmed chain or manual time set with the TIME dial used.

Cook HI/LO Fan Button

The COOK HI/LOW FAN button puts the control into a cook mode and enables the heating elements. Each time the button is pressed, the control switches between the high or low fan speeds. If neither fan is enabled, the high fan speed is selected automatically. The HI FAN and LO FAN indicators show, which fan speed, is selected.

Hold Button

The HOLD button is used to set up the Hold Mode. The user presses the HOLD button and sets the desired temperature and continuous or cycled fan. During the Hold setup mode, the HOLD indicator is lit and the CYCLE indicator is lit if the cycled fan is selected.

During the cook portion hold mode, the timer counts down to zero. During the hold portion, the timer counts up from zero.

Fan Con/Cyc Button

The FAN CON/CYC button enables the fan to run continuously during the cooking cycle, or run only when the control is calling for heat. The display will show FAN CYC when the cycled fan mode is selected and FAN CON when the continuous mode is selected. The CYCLE indicator will light when the cycled fan is enabled.

Program Mode On/Off Button

This button allows the user to activate the programming mode. When this mode is selected, normal oven operation is suspended. The programming mode allows the user to program the cook chains. When this button is pressed again, the program mode is exited and normal oven operation is resumed. When the programming mode is entered the PGM indicators flash.

Event # Button

During the programmed chain cooking operation, this button is used to recall the time remaining in the current event. In the programming mode, this button is used to sequence to the next event to be programmed. During manual operation, this button is disabled.

Program Buttons (1-5)

The five (5) programming buttons are provided for chained cooking. Programs 1 and 2 provide the user with 6 events each, and programs 3, 4 and 5 provide 4 events each. The user sets the value programmed for each event. The Program buttons are locked out when the control is running a manual timed cook.

1 Event = time, temp, fan speed, fan mode.

Cancel Button

The CANCEL button is provided to clear the timer and enable the program buttons and rotary dials. It also cancels the Programming Mode, the beeper, and turns off any indicators that are no longer needed.

Power Up

On initial power up, the time digits will always display zeros with a colon. The temperature digits will display zeros with the degree (°) indicator lit. The C will also be lit in the display if the Celsius option is selected. When the control is turned off, the temperature/timer setting is stored. When the control is turned on again, it will automatically return to the last set time and temperature

Cool Down

This feature enables the oven to be cooled rapidly by allowing the fan to operate with the

heating elements turned off. To activate, turn the Power Switch to the COOL position and open the oven door. Then the door is opened enough to disengage the door switch, the fan will turn on. Closing the door will turn the fan off.

Manual Cooking

A normal, non-programmed cooking cycle can be initiated as follows:

- Turn Power Switch to COOK position.
- Set the desired time using the TIME dial.
- Set the desired temperature using the TEMP dial.
- Select the desired fan speed using the COOK HI/LO FAN button.
- Select the fan to be on continuously or cycled using the FAN/ CON/CYC button.
- Set the HOLD temperature, if desired.
- Press the START TIME button to start the cooking cycle.
- Pressing the CANCEL button will “zero” the Timer at any time.

Programmed Chain Cooking

With the control in normal operating mode, press the desired chain (PBM 1-5) button. If the selected chain has been programmed, the first event will be loaded. The timer will not start until the START TIME button is pressed. The oven temperature will be controlled to the temperature programmed to the first event.

Chain Programming

Each of the 5 PGM buttons can be programmed to perform a different sequence or “chain” of events. Each event, or step, includes a setting for the time, temperature, fan speed, and fan mode. **PGM 1** and **PGM 2** allow the user to set up to **6 events** to be performed during the cooking cycle, while **PGM 3**,

PGM 4 and **PGM 5** allow up to **4 events**. The **last** event for any of the Programmed Chains can be set to be a Hold mode. Programming the PGM buttons is performed as follows:

- Turn Power Switch to **COOK** position.
- Press the **PGM MOD ON/OFF** button to enter the programming mode. All PGM indicators will flash and the balance of the display will be blanked.
- At this time, one of the **PGM Button's (1-5)** must be pressed to select which chain is to be programmed. When the desired PGM button is pressed, the appropriate PGM indicator will remain flashing and event 1 time and temperature will be displayed. The event number (**E1-E6**) will be displayed alternately with the temperature digits.

-
- To change the event time, turn the **TIME** dial. The time entered will be displayed in the time digits.
 - To change event temperature, turn the **TEMP** dial for the desired set temperature. The temperature entered will be displayed in the temperature digits. The event number display will not be shown while the **TEMP** dial is being rotated.
 - To change the fan speed, press the **COOK HI/LO FAN** button. The display indicators will show the selected cook mode.
 - Press the **FAN CON/CYC** button to select continuous or cycled fan. The display will show **FAN CON** or **FAN CYC** to indicate which mode is selected. The **CYCLE** indicator will light if the cycled fan is enabled.
 - To set up a hold mode, press the **HOLD** button. The **HOLD** indicator will be lit when this mode has been selected.

When an event is programmed as a Hold, that event will be the last recognized event of the chain. As an example, if Event 3 is set up as a Hold and Event 4 was set up as a Cook, Event 4 would be ignored.

- To exit the Programming mode, press the **PGM ON/OFF** or **CANCEL** button. The programmed parameters of the previously programmed chain will be saved at this time.
- To program another event within the same chain, press the **EVENT #** button. The parameters of the previous event are saved at this time and sequential event will be displayed. If the previous event was the last of the chain, the first event will be displayed.
- To program another chain, press the desired **PGM BUTTON (1-5)**. Event 1 of the selected chain will be displayed and the parameters of the previously programmed chain will be saved at this time.

EXAMPLE: MUFFINS

Event 1: Cook temp - 400°F, LOW fan speed, cycled fan, cook time = 4 minutes

Cycled, low fan allows the muffins to rise and skin over without being distorted by the air movement.

Event 2: Cook temp = 400°F, HIGH fan speed, continuous fan, cook time = 8 minutes.

Once the product is skinned over, the continuous, high-speed fan will finish the cooking.

TOTAL COOK TIME = 12 MINUTES

(This is an example; your results may vary.)

“ZX” Controller

Oven Controls – Solid State Digital Control with Rack Timer Capability.

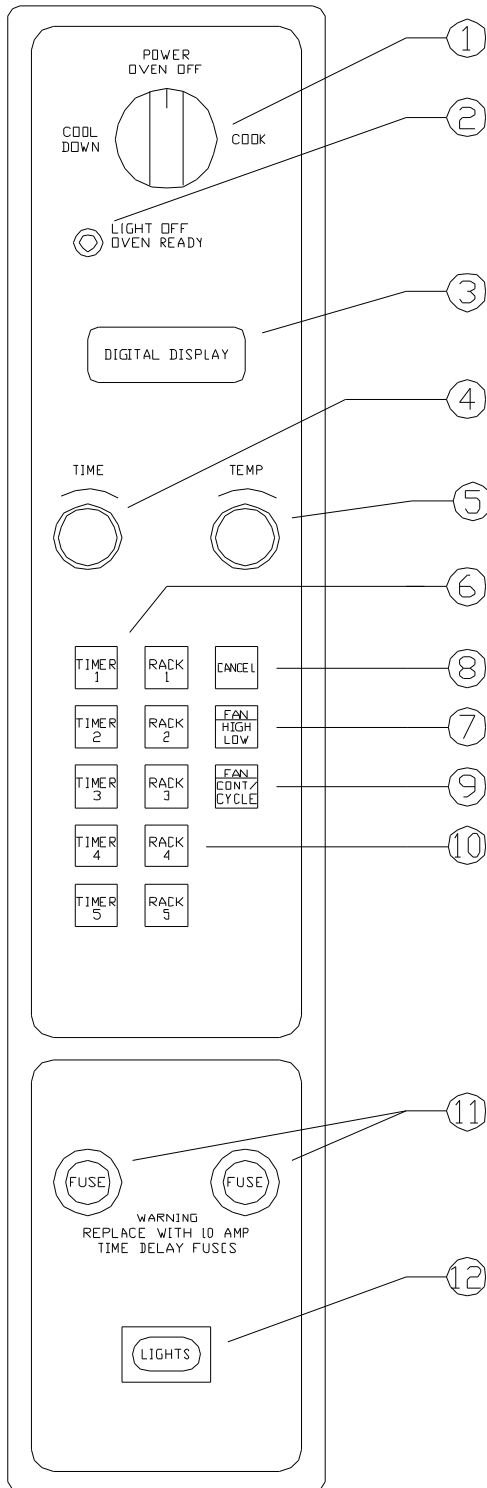

- 1. **The Power Switch** – Controls power to ON or Cool Down function.
- 2. **The Indicator Light** – When lit indicates burners are operating. When the light goes out, the oven has reached its cooking temperature.
- 3. **The Digital Display** – Indicates time and/or temperature.
- 4. **The Time Dial** – Sets countdown timer for cook cycle.
- 5. **The Temperature Dial** – Sets cooking temperature.
- 6. **The Timer Selector Buttons** – Used to select which timer will be used for the product to be cooked.
- 7. **The Fan HI-LO Button** – Sets fan speed to high or low.
- 8. **The Cancel Button** – Cancels preset time and/or temperature.
- 9. **The Fan Continuous/Cycle Button** – Allows setting of fan to run continuously or turn on and off with the burners during the cooking cycle.
- 10. **The Rack Selector Buttons** – Allows setting of fan to run continuously or pulse on and off during the cooking cycle.
- 11. **The Fuse Holders** – Contain circuit protecting fuses.
- 12. **The Light Switch** (optional) – Controls interior lights.

Programming & Operating Instructions

“ZX” Controller

Timer Resolution

The Timer displays time in two different scales. From 0 to 60 minutes, the time is displayed in Minutes/Seconds (“MN” Mode). From 1 to 12 hours, the time is displayed in Hours/Minutes (“HR” Model). The mode indicators are located in the first number digit to the left of the colon.

Temperature Scale

The controller can be set to display the temperature in °F or °C as follows:

- Turn Power Switch to **COOK** position.
- Set **TIME** to 00:00 and **TEMP** so “20” is displayed in the right two temperature digits.
- Press and hold the **START TIME** button for 5 seconds. The control will display “CCC” or “FFF” in the temperature digits to indicate it has entered the mode.
- Entering will toggle between “CCC” and “FFF”. Pressing and holding the **RACK 1** button again will also toggle the setting.
- Turn Power Switch to **OFF** position to exit.

Power Input Frequency

The controller will automatically set itself to operate on 50Hz or 60Hz, depending on the power source used. All timers and internal clocks are automatically compensated.

Timed Dial

The **TIME** dial sets time intervals for cooking. It is used in either programming or manual cooking.

Rack Buttons (1-5)

The five (5) Rack Buttons are provided to allow up to 5 individual shelves, or racks, to be timed at different intervals. The shelves can be selected in any order. The temperature setting must be the same for each rack button.

Temp Dial

The **TEMP** dial sets the temperature. The temperature changes in 5°F or 1°C increments.

Fan High Low Button

The **FAN HIGH LOW** Button puts the control into a cook mode and enables the heating elements. Each time the button is pressed, the control switches between the high or low fan speeds. If neither fan is enabled, the high fan speed is selected automatically. The **HI FAN** and **LO FAN** indicators show, which fan speed, is selected.

Fan Con/Cycle Button

The **FAN CONT/CYCLE** Button enables the fan to run continuously during the cooking cycle, or run only when the control is calling for heat. The display will show **FAN CYC** when the cycled fan mode is selected and **FAN CON** when the continuous mode is selected. The **CYCLE** indicator will light when the cycled fan is enabled.

Time Selector Buttons (1-5)

The five (5) Timer Buttons are provided to allow up to 5 different preset time intervals to be programmed. When a Time button is pressed, its timed setting will be recalled and displayed in the time digits.

Cancel Button

The **CANCEL** Button is provided to clear the End of Cycle beeper or “zero” a non-running timer. A running timer can be cancelled by pressing the selected Rack button to recall the timer and then pressing the **CANCEL** button within 3 seconds.

Cool Down

This feature enables the oven to be cooled rapidly by allowing the fan to operate with the heating elements off. To activate, turn the Power Switch to the **COOL** position and open the oven door. When the door is opened enough to disengage the door switch, the fan will turn on. Closing the door will turn the fan off.

Power Up

On initial power up, the time digits will always display zeros with a colon. The temperature digits will display zeros with the degree (°) indicator lit. The **C** will also be lit in the display if the Celsius option is selected. When the control is turned off, the temperature/timer setting is stored. When the control is turned on again, it will automatically return to the last set time and temperature.

Timer Buttons

Each of the **TIMER** buttons can be programmed to a different setting. Pressing and holding a **TIMER** button and setting the timer dial to the desired setting programs them. When the **TIMER** button is released, the displayed time is saved.

Manual Cooking

A normal cooking cycle where the entire product to be cooked is placed in the oven at once can be initiated as follows:

-
- Turn Power Switch to **COOK** position
 - Set the desired temperature using the **TEMP** dial.
 - Select the desired fan speed using the **COOK HI/LO FAN** button.
 - Select the fan to be on continuously or cycled using the **FAN CON/CYC** button.
 - Set the desired time using the **TIME** dial or selecting one of the preset **TIMER** buttons.
 - Press one of the **RACK** buttons to start the cooking cycle. The timer will begin to count down and the selected Racks indicator will begin flashing.
 - Pressing the selected **RACK** button and then the **CANCEL** button within 3 seconds will “zero” the Timer at any time.
 - The Alarm will sound at the end of the cooking cycle. Pressing the **CANCEL** or selected **RACK** button will cancel it.

Timed Shelf Cooking

A cooking cycle where the product to be cooked is placed in the oven one pan or shelf at a time can be initiated as follows:

- Turn Power Switch to **COOK** position.
- Set the desired temperature using the **TEMP** dial.
- Select the desired fan speed using the **COOK HI/LO FAN** button.
- Select the fan to on continuously or cycles using the **FAN CON/CYC** button.
- Place pan on first shelf.
- Set the desired time using the **TIME** dial or selecting one of the preset **TIMER** buttons.
- Press the **RACK 1** button to start the cooking cycle. The timer will begin to count down and the **RACK 1** indicators will begin flashing.
- Pressing the selected **RACK** button and then **CANCEL** button within 3 seconds will “zero” the Timer at any time.
- Place the next pan on second shelf.
- Set the desired time using the **TIME**

dial or selecting one of the preset **TIMER** buttons.

- Press the **RACK 2** button. The **RACK 2** indicator will light. The Time will resume counting down.

The procedure of placing a pan on a shelf, selecting the desired time, and pressing the corresponding **RACK** button can be repeated for a total of 5 Shelf/Rack combinations.

- When **RACK 1** reaches “zero”, the alarm will sound and “-1-“ will be flashing in the display. Pressing **CANCEL** or **RACK 1** button will cancel it.
- After the alarm is cancelled, the Timer will display the remainder of the countdown for the **RACK** with the least amount of time left and its indicator will begin flashing.

This will be repeated until all of the **RACK** Timers reach “zero”.

“ZZ” Controller Key Descriptions

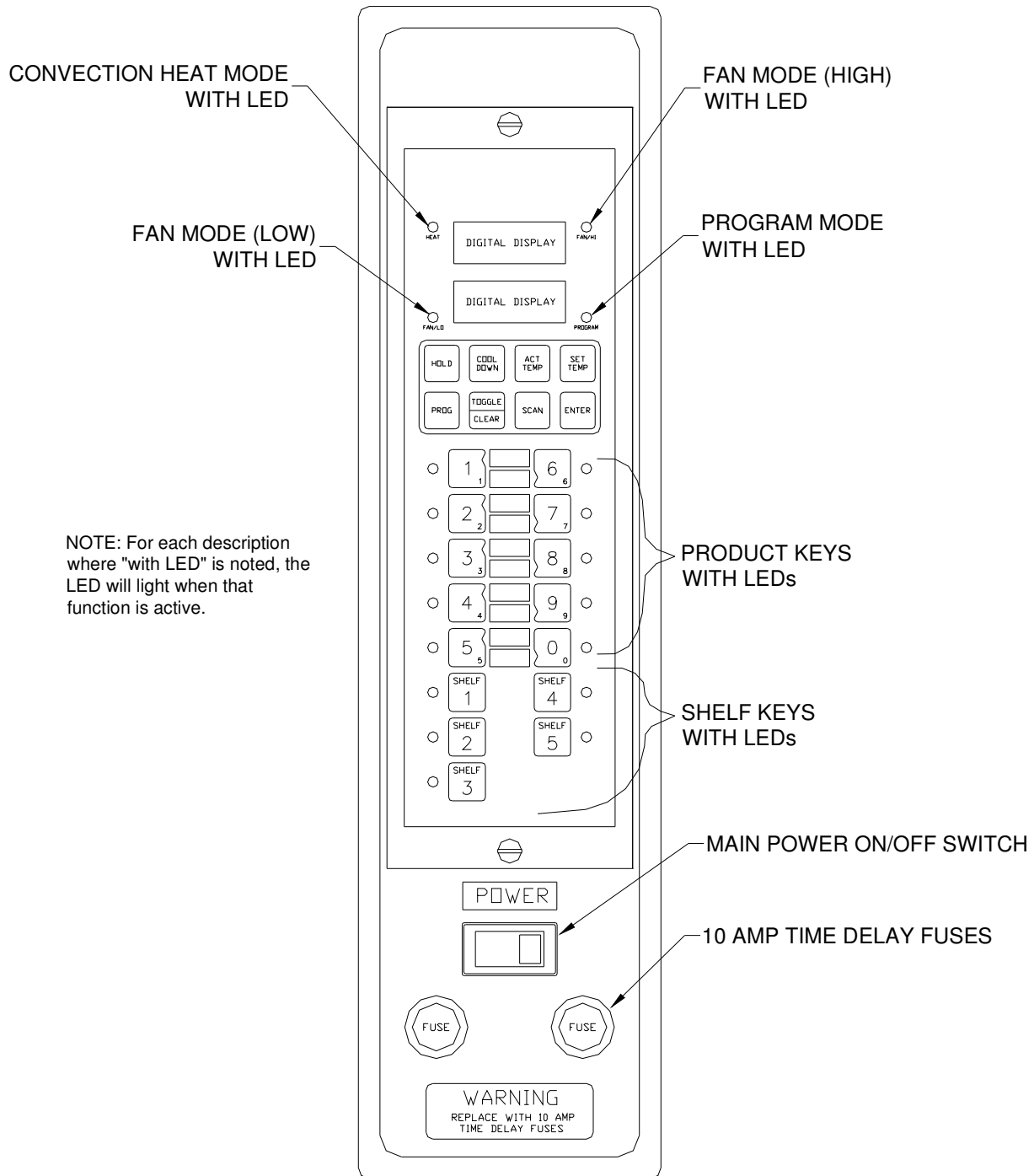

“ZZ” CONTROLLER PROGRAMMING & OPERATION INSTRUCTIONS

The (FASTRON.)[®] IM-2000[®] Convection Oven Controller is designed to simplify your cooking process and allow your foodservice operators to spend more time with the customers and other important responsibilities. Quality control of your food product is assured through the various features, notification displays and alarms designed into the controller.

There are four modes of operation on the controller:

- Operating Mode:** Used to cook various menu items
- Programming Mode:** Used to enter cooking recipes
- System Programming Mode:** Used to set oven parameters

PROFILE BAKING

The (FASTRON.)[®] IM-2000[®] Convection Oven Controller provides one-touch control of the entire baking process by allowing you to divide each product bake cycle into six distinct stages or “profiles”. Each stage can be programmed for time, temperature, fan speed, controller-compensated time, or straight time countdown mode.

Using profile baking with muffins, for example, yields excellent results. Here is an example of a typical controller bake cycle for an oven load of muffins, half corn and half blueberry:

- Profile 1: Begin at 400°F for 5 minutes with fan on.
- Profile 2: After 5 minutes, when the muffin batter has risen to the top of the cups, we’ll program the fan off for the next 10 minutes to allow the muffins to rise high and evenly.
- Profile 3: We’ll now turn the fan back on and set oven temperature to 375°F for the next 5 minutes, permitting an even bake through the center of the product.
- Profile 4: During the last 5 minutes of the bake cycle, we want to set the muffin peaks and finish them off to a golden color, so we’ll increase the temperature to 400°F.

Welcome to profile baking! Please take the time now to read the Programming Instructions for the (FASTRON.)[®] IM-2000[®] Convection Oven Controller.

Operating the Controller

1. Turn appliance power switch ON.
2. Select a product key. Press the key once (product LED lights up) to heat oven to proper baking temperature.
3. When the correct temperature is reached, the computer will read rEdY and be accompanied by a self-cancelling audible signal.
4. Load the oven and press the product key to start the bake cycle countdown. If you are using the Shelf ID feature, SHLF will appear in the top display. Press the corresponding shelf key number to indicate oven shelf location and countdown will begin.

If you make an error in selecting your shelf number press the TOGGLE CLEAR key, then the shelf number and begin again.

5. At the end of the bake cycle, press the flashing product key to cancel the alarm, and remove the product from the oven.
- 5.1 For shelf cook, press the flashing shelf key.
6. To cancel the bake cycle before completion when using Shelf ID, press the TOGGLE CLEAR key then the shelf number you wish to cancel.
7. To cancel a bake cycle during countdown, press and hold that product key for 3 seconds.

NOTE:

You may add simultaneous or subsequent trays of the same or different products to the oven if the corresponding LED is lit. Products which are baked using more than one profile cannot be used with staggered loading or shelf identification.

NOTE:

When profile cooking is to be used, the countdown time displayed is the sum of all the stages.

CONTROLLER RESET

In rare situations such as a lightening strike near the facility, the controller may lose its program or become “locked up”. If this should happen turn the power to the oven off. Press and hold the toggle/clear button while turning the power to the oven on. Resetting the controller resynchronizes its program flow.

CONTROLLER FEATURES

Recovery Time

From a cool start-up (below 140° F) the controller will time how long the oven takes to go from 150-300° F. Once the timer starts the oven must reach 300° F. If 300° F is not reached, the oven recovery mode will not operate correctly. To access this feature, press the ENTER key. If the temperature does not get above 300° F in 10 minutes, the controller will show HEAT ERR indicating a possible problem with the system. This should be looked at by a technician. Pressing the TOGGLE/CLEAR key will clear this prompt.

Fahrenheit or Celsius Temperature Display

The operator will have the ability to configure the controller to display the temperature in degrees Fahrenheit or Celsius from the System Programming mode.

Hold

The operator will have the ability to set an auto hold for each product key. Time (9 hours max.), temperature (140-210° F), and fan speed (low or high) are programmable.

Programmable Times

The operator will have the ability to program the cook times for each product key. The controller is programmable in hours (18), minutes (up to 59) and seconds (up to 59).

Programmable Temperatures

The operator will be able to program cook temperatures for each product key. The valid temperature range is 100° F to 450° F (38° C to 232° C).

Programmable (FASTFLEX.) Timing Mode

The operator will be able to program the timing mode (flex, straight or sensitivity) for each product key. If a product is configured for flex time, the controller will use (FASTFLEX.) to adjust the actual cook time taking into consideration the temperature variation due to load size, initial product temperature, product moisture content, and other factors affecting the cook cycle, to insure the controller provides consistent, high-quality product. Under straight time mode, the controller will cook only for the specified time without adjusting for these variations. Sensitivity time allows the operator to set a level (0-9), which will adjust the actual cook time based on temperature curve.

Shelf ID

The operator will have the ability to set the number of shelves the oven has (up to 5).

Setback

A feature that cools the oven to a programmed temperature after a predetermined amount of time. The operator will be able to program the setback time frame (max. 59 mins./59 secs.) and setback temperature (140-300°F).

Offset

This feature will allow an authorized operator to adjust the display temperature to match the center oven temperature.

DISPLAY DESCRIPTIONS

- Lo** The unit is in the Operating Mode. The actual oven temperature is more than 10° F below the active programmed key temperature.
- rEdY** The unit is in the Operating Mode. The actual oven temperature is within the proper cooking temperature range. The oven is ready to start the cook cycle.
- Hi** The unit is in the Operating Mode. The actual oven temperature is more than 40° F above the programmed key temperature. An audible alarm sounds simultaneously.
- HELP** The actual oven temperature is above 570° F. Turn oven OFF. Call for service.
- ProB** The controller probe is either open or shorted; accompanied with an audible alarm if shorted. Check or replace the probe. Turn oven OFF. Call for service.
- 2:30** The unit is in the Operating Mode and a cook cycle is in process.
- donE** The unit is in the Operating Mode and a cook cycle has been completed.
- CodE** The unit is waiting for a pass code to be entered.
- Prod** The unit is in the Product Key Programming Standby Mode.
- P1:**
- 12:00** A cooking time is displayed.
- Ct-1**
- 350F** A cooking temperature is displayed.
- tC** A timing mode (flex, straight or crisp) is displayed.
- SYS** The unit is in System Programming Standby Mode.
- dE9** The unit is in Fahrenheit or Celsius Programming Mode.
- APPL** The unit is in the Appliance Type Programming mode.
- SPd** A fan mode is displayed (high or low).
- CYC** A fan cycle (heat, full, pulse).
- SHLF** Shelf mode is displayed.
- HoLd** The unit is in Hold Programming mode.
- SEtb** The unit is in Setback mode.
- APPL** The unit is in Appliance mode.
- tYPE** The unit is in Appliance version.
- rEC** The unit is in Recovery Count mode.
- oFF**
- Set** The unit is in Programming Offset mode.

Programming Fan Speed

Press:		TOGGLE CLEAR	ENTER	SCAN
Display:	SPd1 ↓ Hi currently programmed fan speed is displayed	SPd1 ↓ Lo to change speed of the fan to program additional	SPd2 ↓ Hi currently programmed temperature is displayed; and continue product cook temperature repeat from Toggle Clear step	CYC1 ↓ FULL to keep new fan speed with "Programming Fan Cycle Time"

Programming Fan Cycle Time

There are 3 options to choose from: PULSE (programmable fan on and off time, HEAT (fan on only with heat, FULL (continuous fan).

IF YOU CHOOSE PULSE:

Press		TOGGLE CLEAR	SCAN	TOGGLE CLEAR	4 5	SCAN	TOGGLE CLEAR
Display	CYC1 FULL ↓	CYC1 PULS ↓	on-1 :3↓	on-1 ↓	on-1 :FF↓	of-1 ↓0	of-1 ↓
	Currently Programmed Fan cycle is Displayed	To change Fan cycle	Currently Programmed ON time is Displayed	To clear fan ON time	Enter new Fan ON Time	Currently Programmed OFF time is displayed	To clear fan OFF time

Press	2 5	SCAN	TOGGLE CLEAR	SCAN	TOGGLE CLEAR	SCAN
Display	of-1 ↓ :25	tc-1 ↓ SEnS	CYC-1 ↓ FULL	tc-1 ↓ SEnS	CYC-1 ↓ HEAT	tc-1 ↓ SEnS
	enter new Fan OFF time	To keep new fan OFF time and continue With "Programming Timing Mode"	To change Fan cycle	To keep new fan cycle and continue with "Programming Timing Mode"	To change fan cycle	To keep new fan cycle and continue with "Programming Timing Mode"

Programming Timing Mode

<i>Press</i>		TOGGLE CLEAR	SCAN	TOGGLE CLEAR	SCAN	3	SCAN
<i>Display</i>	tc-1 ↓ St	St ↓ FL	SHLF ↓ no	FL ↓ SEnS	SEnS ↓ : 0	3 ↓ :30	SHLF ↓ no
	Currently Programmed timing mode is Displayed	To toggle between choices	To keep Timing mode choice and Continue with "Programming Shelf ID"	To toggle between choices	Currently programmed crisp level is displayed	Enter new crisp level	To keep new crisp level and continue With "Programming Shelf ID"

additional profiles, press ENTER ** NOTE: To program

When all profiles have been programmed, proceed by pressing SCAN

Programming Shelf ID

<i>Press</i>		TOGGLE CLEAR	SCAN	Note: If using multiple profiles Shelf ID is not allowed.
<i>Display</i>	SHLF ↓ Yes	SHLF ↓ no	Hold ↓ no	
	Currently Programmed Shelf identification Mode is displayed	To change shelf identification mode YES=on NO=off	To keep new Shelf ID information	

Programming Hold Display Time and Temperature (Automatic Hold Cycle)

Press:		TOGGLE CLEAR	SCAN	TOGGLE CLEAR	2 3 0	SCAN
Display:	Hold	Hold	Hold	Hold	Hold	Hold
	↓	↓	↓		↓	↓
	no current hold display mode is displayed	YES to toggle between choices	:30 current hold display mode time is displayed; up to a maximum of 9 hrs can be programmed	0 to change time	2:30 enter new time	100° F current hold temperature is displayed; from 140° F to 210° F

Press:	TOGGLE CLEAR	2 0 0	SCAN
Display:	Hold	Hold	HFA n
	↓	↓	↓
	0F to change temperature	200F enter new temperature	Hi to keep new hold temperature and advance to hold fan speed option

Programming Fan Mode

Press:		TOGGLE CLEAR	SCAN
Display:	HFA n	HFA n	SEt b
	↓	↓	↓
	Hi currently programmed fan mode is displayed	Lo to toggle between choices	YES to keep new fan mode and continue with programming next product key

Exiting Programming Mode

Press:	SCAN	PROG	Press PROG when any of these functions are displayed
Display:	Prod	----	Prod SYS:

Entering System Programming Mode

Press:	PROG	4	5	1	2	ENTER
--------	-------------	----------	----------	----------	----------	--------------

Display :CodE = == === ===== SYS
 The controller is now in System Programming Standby Mode.

Programming Hold Display Time and Temperature (Manual Hold Cycle)

Press:		SCAN	TOGGLE CLEAR	SCAN	TOGGLE CLEAR	2 3 0	SCAN
Display:	SYS	Hold	Hold	Hold	Hold	Hold	Hold
		↓	↓	↓		↓	↓
		no	YES	:30	0	2:30	100° F
		current hold display mode is displayed	to toggle between choices	current to change hold display mode time is displayed; up to a maximum of 9 hrs can be programmed	enter new time	current hold time	temperature is displayed; from 140° F to 210° F

Press:	TOGGLE CLEAR	2 0 0	SCAN
Display:	Hold	Hold	HFA n
	↓	↓	↓
	0F	200F	Hi
	to change temperature	enter new temperature	to keep new hold temperature and advance to hold fan speed option

Programming Fan Mode

Press:		TOGGLE CLEAR	SCAN
Display:	HFA n	HFA n	SEtb
	↓	↓	↓
	Hi	Lo	YES
	currently programmed fan mode is displayed	to toggle between choices	to keep new fan mode and continue with "Programming Setback"

Programming Setback Mode

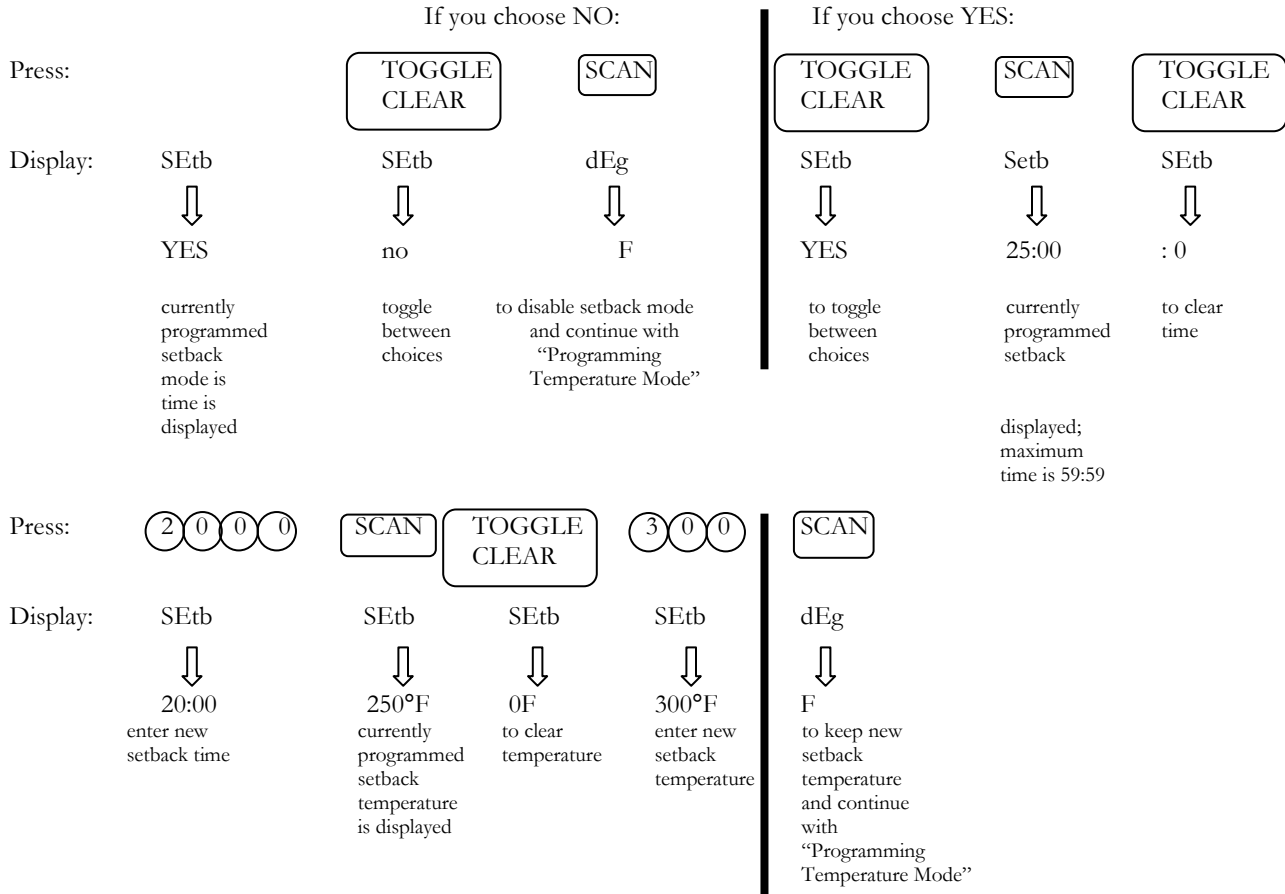

Programming Temperature Mode (Fahrenheit or Celsius)

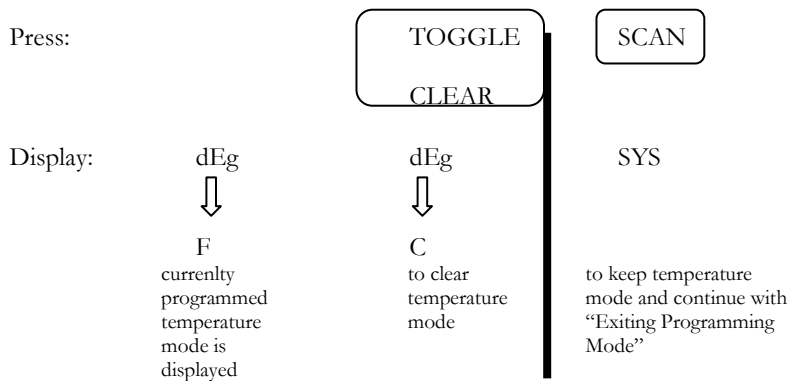

Exiting System Programming Mode

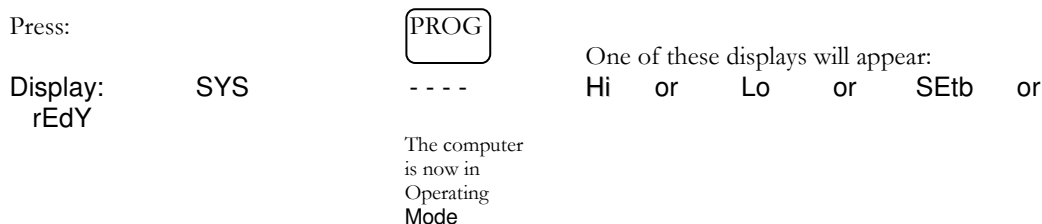

“ZZ” Controller Repair Parts List

Part #	Description
153036	Motor, 208/240v, 2-speed, 1/2 HP
153210	Terminal block
153157	Contactactor, 208/240v, 3-pole, 30 amp
153159	Contactactor, 208/240v, 2-pole, 60 amp
155077	Element, inner, 240v, 2.667 KW
155078	Element, center, 240v, 2.667 KW
155079	Element, outer, 240v, 2.667 KW
155074	Element, inner, 208v, 2.667 KW
155075	Element, center, 208v, 2.667 KW
155076	Element, outer, 208v, 2.667 KW
153093	Blower wheel
155132	Door glass
153056	Bearing, door
155404	Door handle
148077	Door micro switch
153200	Fuse holder
153201	Fuse, 10 amp, time delay
155006	Gasket, door bottom
155007	Gasket, door top
155008	Gasket, door side (2 required)
155197	Baffle, fan
155115	Screws, thumb
155113	Support rack, oven
155114	Rack, oven
155107	Actuator, door
155451	Door, with glass hinged right
155454	Door, with glass hinged left
153416	Catch, door
153801	Latch, roller assembly
154379	Probe, temperature, “ZZ” type
154378	Controller, “ZZ”
512289	Switch, ON/OFF
153368	Blower assembly, electric, 2-speed
153156	Contactactor, 3 pole, 50 amp, 208/240 volt
154386	Transformer, 208/240 volt
154383	Alarm box, remote
154377	PCB assembly, 3 relay, IM 2000
154381	Relay, remote alarm, 208/240 volt
154384	Cord, phone, 140'
600100	Kit, Flue Guard (Optional)
155125	Bracket, Stacking

B. GENERAL GUIDELINES FOR OPERATION

These guidelines are to assist you in obtaining the best performance from your oven:

- Always pre-heat your oven before cooking by placing the temperature setting at the desired temperature. The oven is pre-heated when the Indicator Light goes out.
- Always use a lower temperature setting than that recommended for a standard conventional oven or range oven. The general rule of thumb is to subtract 50 - 100°F from the standard oven recipe. Some experimentation on your part may be necessary to achieve the optimum results with your food products.

Cooking at higher temperatures will not reduce your cooking time! It will produce unsatisfactory baking and roasting results.

- You should begin checking the doneness of your food product in about half the time recommended for the same recipe cooked in a standard oven. There is a Suggested Time and Temperature Chart on the next page, which can serve as a guide. Keep in mind that your times may vary depending on the amount of product being cooked in your oven. The best results are always achieved when a systematic record of times and temperatures is kept for reference.
- The oven will hold up to thirteen 18" x 26" (457mm x 660mm) sheet pans. Your product and pan height will determine how many racks can be loaded.

Do not place an empty sheet pan or aluminum foil on the bottom of the oven. This will disrupt the airflow and cause uneven cooking results.

- To minimize the shrinkage of roasted meats, place the meat directly on the racks and place a sheet pan one half full of water in the bottom rack

position. The water will keep the oven compartment more humid and the meat juices will evaporate less.

- Maintain equal loads when cooking more than one pan of product at a time. You may wish to weigh the product to assure that the pan loads are equal. Smaller loads in one pan will cook at a different rate than larger ones in another.
- You may wish to experiment with leaving the oven OFF after pre-heating the oven and loading when baking light products such as light cake batter or custard so the product will have time to set. Normally, 7-10 minutes with the oven OFF, then finishing with the oven ON, will keep the product from rippling or being pushed by the fan.
- When starting off with frozen product, you may wish to pre-heat your oven up to 100° F above the temperature you are going to cook. Load the product and reset the temperature for the normal time.
- For longer bulb life, do not leave the oven lights on when not viewing the product.

OPERATION INSTRUCTIONS

The information in this section is intended for the use of qualified operating personnel. Qualified Operating Personnel are those individuals who have carefully read the information contained in this manual, are familiar with the function of the oven and/or have had experience with operating the equipment described. We recommend following these instructions to insure optimum performance, long life and trouble-free service from your oven.

The 6/13 Electric Convection Ovens

Convection cooking has been around from the 1960s. Its advantages are well known. It differs from conventional cooking by the movement of heated air within the cooking cavity by means of a fan. This moving, heated air helps to strip the cool air from around the product being cooked, allowing the heat to penetrate more rapidly. The results are that your product is cooked quicker and at a lower temperature with the comparable product quality found in conventional ovens.

Please take the time to carefully read the operating instructions. They are important in the successful use of your oven.

IMPORTANT NOTE: The “6/13” Convection Ovens rely on electricity for powering the ignition system and the fan. Do not attempt to operate during a power failure.

C. Suggested Times & Temperatures

	PRODUCT	°F	°C	COOK TIME	RACKS	TEMP	TIME	
BEEF	HAMBURGER PATTIES (3.3 OZ.)	400	205	8-10 MIN.	13			
	MEAT LOAF	325	165	40-45 MIN.	4			
	STEAMSHIP ROUND (80 LBS. QUART.)	275	135	2-3/4 HRS. F	2			
	ROLLED BEEF ROAST (12-15 LBS.)	275	135	2-1/2 HRS.	4			
	STANDING RIB ROAST (20 LBS. RARE)	235	115	2-3/4 HRS.	2			
	SHELL STEAKS (100Z.)	450	230	7-8 MIN.	6			
	POT PIES	400	205	30-35 MIN.	6			
	STUFFED PEPPERS	350	175	15-20 MIN.	4			
	LASAGNA	260	125	90 MIN.	4			
	HOT DOGS	325	165	10-15 MIN.	6			
PORK	BAKED, STUFFED PORK CHOPS	375	190	25-30 MIN.	6			
	BACON	400	205	5-7 MIN.	13			
VEAL	BONED VEAL ROAST (15 LBS.)	300	150	3 HRS. 10 MIN.	3			
LAMB	LAMB CHOPS	400	205	7-8 MIN.	6			
POULTRY	CHICKEN BREASTS & THIGHS	350	175	40 MIN.	6			
	CHICKEN BACKS & WINGS	350	175	35 MIN.	6			
	CHICKEN, QUARTERED	350	175	30 MIN.	6			
	TURKEY ROLL (18 LB.)	310	155	3-3/4 HRS.	4			
	POT PIES	400	205	30-35 MIN.	6			
FISH	FISH STICKS	335	170	16-18 MIN.	13			
SEAFOOD	COD, HALIBUT (FROZEN)	350	175	20 MIN.	6			
	SHRIMP, BAKED STUFFED	400	205	6-7 MIN.	6			
	LOBSTER, BAKED STUFFED	400	205	10 MIN.	4			
	LOBSTER TAILS (FROZEN)	425	220	9 MIN.	6			
CHEESE	MACARONI & CHEESE CASSEROLE	350	175	30 MIN.	6			
	CHEESE SANDWICHES, GRILLED	400	205	8 MIN.	13			
POTATOES	POTATOES, BAKED (120 COUNT)	400	205	50 MIN.	6			
	POTATOES, SLICED OR DICED	325	165	10 MIN.	6			
	FRENCH FRIES (FROZEN)	TIMES & TEMPS WILL VARY AS TO CUT						
PIES	FROZEN BERRY PIES (36 - 22 OZ. EA.)	325	165	35 MIN.	6			
	FROZEN FRUIT PIES (24 - 46 OZ. EA.)	325	165	45-50 MIN.	6			
	FRESH APPLE PIE (36 - 20 OZ. EA.)	350	175	25-30 MIN.	6			
	PUMPKIN PIE	300	150	30-50 MIN.	6			
	FRUIT CRISP	300	150	25 MIN.	6			
	FRUIT COBBLER	300	150	30 MIN.	6			
BREADS	APPLE TURNOVERS	350	175	15 MIN.	6			
	BREAD (32 - 1 LB. LOAVES)	325	165	30 MIN.	4			
	CORN BREAD (NORTHERN)	325	165	25 MIN.	6			
	CORN BREAD (SOUTHERN)	375	190	15-20 MIN.	6			
	HAMBURGER ROLLS	275	125	15 MIN.	6			
	YEAST ROLLS	300	140	25 MIN.	6			
	BISCUITS	400	205	6 MIN.	6			
	ROLLS, BROWN & SERVE	350	175	15 MIN.	6			
	CAKES	SHEET CAKES (5 LBS. BATTER PER PAN)	325	165	16-18 MIN.	6		
	COOKIES	CHOCOLATE CAKE	325	165	20 MIN.	6		
BROWNIES		325	165	15 MIN.	6			
DANISH PASTRY		325	165	12 MIN.	6			
CINNAMON BUNS		325	165	20 MIN.	6			
SUGAR COOKIES		275	125	15 MIN.	13			
CREAM PUFFS		325	165	20-25 MIN.	6			
CHOCOLATE CHIP COOKIES		325	165	10 MIN.	13			
PEANUT BUTTER COOKIES		300	150	10 MIN.	13			

NOTE: Your times and temperatures may vary from those shown on this chart. Your results depend on weight per pan, temperature of the product before loading, the recipe, type of pan, and calibration of the thermostat. If your recipes vary from these, write in your proven times and temperatures for your future use.

D. COOK & HOLD/ROAST & HOLD RECOMMENDED TIME & TEMPERATURE

PRODUCT	QTY	COOK TEMP	HOLD TEMP	COOK TIME	HOLD TIME MINIMUM	TOTAL TIME
PRIME RIB BONE IN CAP OFF 14 – 18 LBS (6.4 – 8.1 KG)	1 3 6	200°F 93°C	140°F 60°C	3 HRS 3-1/4 HRS 3-1/2 HRS	1 HR 1-1/2 HRS 2 HRS	4 HR 4-3/4 HRS 5-1/2 HRS
PRIME RIB BONE IN CAP ON 18 – 22 LBS (8.1 – 10 KG)	1 3 6	200°F 93°C	140°F 60°C	3-1/2 HRS 4 HRS 4-1/2 HRS	1 HR 1-1/2 HRS 2 HRS	4-1/2 HRS 5-1/2 HRS 6-1/2 HRS
TOP OR BOTTOM ROUNDS 10 – 12 LBS (4.5 – 5.4 KG)	1 3 6	200°F 93°C	140°F 60°C	3-1/2 HRS 4 HRS 4-1/2 HRS	1 HR 1-1/2 HRS 2 HRS	4-1/2 HRS 5-1/2 HRS 6-1/2 HRS
PORK ROAST OR HAM CAP OFF 10 – 12 LBS (4.5 – 5.4 KG)	1 3 6	250°F 121°C	170°F 76°C	4 HRS 4-1/4 HRS 4-1/2 HRS	1 HR 1-1/2 HRS 2 HRS	5 HR 5-3/4 HRS 6-1/2 HRS
TURKEY 20 - 22 LBS (6.4 – 8.1 KG)	1 2	250°F 121°C	170°F 76°C	3-3/4 HRS 4 HRS	1 HR 1-1/2 HRS	4-3/4 HR 5-1/2 HRS
LEG OF LAMB BONE IN 8 - 10 LBS	2 4 6	225°F 107°C	160°F 71°C	2-1/2 HRS 2-3/4 HRS 3 HRS	1 HR 1-1/2 HRS 2 HRS	3-1/2 HR 4-1/4 HRS 5 HRS

COOK & HOLD - ROAST & HOLD

Control Options with COOK & HOLD - ROAST & HOLD feature include conveniences not found in standard control ovens. This feature is particularly valuable when roasting meats. By using the slower speed "Roast - Lo Fan" for the primary cooking cycle and setting a lower temperature (140°F or higher is recommended) for the hold cycle, your meats can be cooked and then held for up to 16 hours. The lower temperatures used and the slower fan speeds reduce shrinkage, thus increasing yields. Also, meats roasted in this manner over longer periods tend to be more tender and juicy.

An added benefit of using your 5/9 to Roast & Hold is lower energy costs.

COOK & HOLD - ROAST & HOLD cooking is a three step process.

- **COOK or ROAST** - This step is controlled by the count down timer and the temperature controller. Meat is roasted at a lower temperature for a longer period of time. Meats are generally cooked until about 2/3 done in this cycle. At the end of the roasting cycle, the controls automatically shift to the "HOLD" mode.
- **STORED HEAT COOKING** - This is a natural change in temperature and is not a controlled function; i.e., there are no times or temperatures to set. It is a portion of the "HOLD" cycle as far as timing. In this step the oven temperature slowly drops down to the "HOLD" temperature setting.

This step may take 1 -2 hours. It is important that meats being cooked by this method be left in the "HOLD" cycle for at least two hours as they continue to cook.

- **HOLD** - Once the meat reaches the holding temperature, it can be held up to sixteen hours prior to serving. The blower at low speed will cycle on and off to maintain the "HOLD" temperature you set into the temperature controller.

NOTE: The "COOK - HI-FAN" cycle can be substituted for the "ROAST-LO-FAN" cycle with the only change being the velocity of the fan being higher.

E. General Guidelines for Cook & Hold - Roast & Hold

- Always allow the meat to remain in the "HOLD" cycle for a minimum of two hours. This will assure that the stored heat of the "COOK - ROAST" cycle has brought it to the desired degree of doneness.
- Always thaw meats in a refrigerator and temper the meat 30-45 minutes at room temperature before cooking. Cooking frozen food products is not recommended, as it will increase the "COOK -ROAST" cycle and increase shrinkage.
- Aged meat cooks more rapidly and this should be taken into consideration when establishing cooking times.

MAINTENANCE INSTRUCTIONS

These maintenance instructions are for the use of qualified service personnel only. Service by other than qualified personnel may result in damage to the oven and/or injury to the operator.

Qualified service personnel are those individuals, firms, companies or corporations which either in person or through an agent are engaged in and responsible for repair or servicing of commercial food preparation equipment, who are experienced in such work, familiar with all precautions required, and have complied with all requirements of state and local authorities having jurisdiction.

If you should require assistance in the selection of a qualified service agency, please contact Duke Manufacturing Co.'s Service Department at 800-735-3853.

A. Adjustments

Quite often malfunctions, which are attributed to defects, may be repaired by adjusting certain parts rather than replacing them.

B. Door Adjustment

All 6/13 Series Convection Ovens (except model option Q) have doors that are inter-connected so they operate simultaneously by means of a chain and turnbuckle assembly. The doors are properly adjusted and inspected before the oven leaves the factory. However, from time to time it may become necessary to readjust the doors after usage. If you find it necessary to adjust the doors for proper operation, the chain and turnbuckle assembly is located behind the panel that is over the doors. It is best to adjust turnbuckles while the door is in an unlatched position.

- Loosen the jam nut on both turnbuckles.
- Make adjustments simultaneously to both turnbuckles.
- Loosening or tightening the assembly will not allow the doors to work properly. Ideally, you should loosen one turnbuckle and tighten the other. Some experimentation will indicate which direction you will want to make your adjustments.
- Once the doors are operating properly, retighten the jam nuts so the unit will stay in adjustment. Test the door to make certain it is in adjustment.
- Replace cover.

C. Door Switch Adjustment

You may also wish to adjust the door switch. The door switch is located behind the combustion compartment

cover, on the right side. The door switch is activated by a cam, which is mounted to the door's hinge pin with a setscrew.

- Open the doors fully.
- Remove the lower cover by loosening the four screws located inside the door opening.
- Position the doors so they are nearly closed but not latched.
- To adjust the cam loosen the setscrew and rotate the cam until you hear the switch click.
- Tighten the setscrew in the cam. Test the door to make certain the switch will make contact with the doors closed.
- Replace the cover.

CAUTION: The door turnbuckles and door switch are located in a heated zone. Care should be taken to avoid burns.

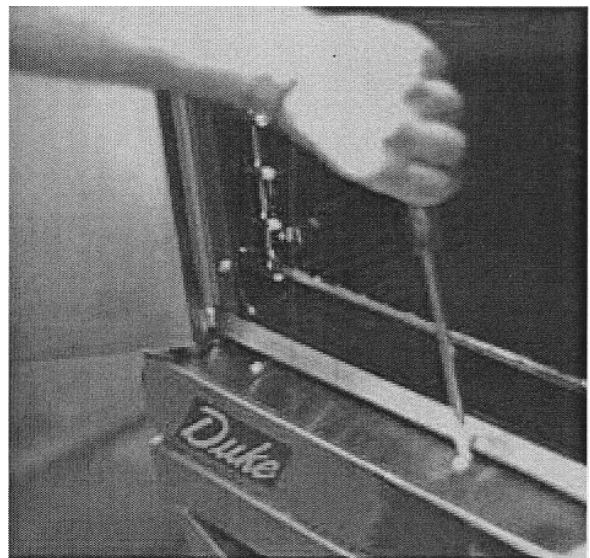

Door Switch Access Panel

D. Thermostat Calibration

Electro-Mechanical Controls Only ("Q" & "V"). Not applicable to Ovens with Solid State Controls.

In many convection ovens thermostats have been the cause of more operating problems than any other component part. Thermostats, being mechanical devices, do sometimes fail, in which case only replacing the part will correct the problem. However, the great majority of thermostat related problems could be attributed to their being out of adjustment (calibration). A thermostat that is out of calibration may cause unsatisfactory cooking results such as

uneven baking, prolonged cooking times, etc. If you are experiencing uneven cooking, it may be a result of excessive cooking temperatures. Refer to the cooking chart provided in Operating Instructions Section C.

To Check Calibration:

- Turn the oven on by turning the Power Switch to the ON position.
- Open the doors and place a thermocouple in the center of the middle oven rack. A reliable mercury-type thermometer can be substituted if a pyrometer is not available.
- Turn the thermostat dial to 350°F (177°C). Allow the oven to preheat 1/2 hour.
- When the indicator light goes out, the thermostat has been satisfied. Check the pyrometer or thermometer to determine the internal oven temperature.
- If the reading on the pyrometer (or thermometer) is less than 10°F different from the setting of the thermostat, no adjustment is needed. If this reading is more than 10°F, proceed with calibration procedure.

To Calibrate the Ovens

- Remove the thermostat knob by loosening the setscrew and pull the knob forward. Take care not to rotate the thermostat stem, which will change the setting.
- With a very small screwdriver, turn the screw located in the bottom of the hollow of the stem clockwise to lower the temperature or counterclockwise to raise the temperature. **DO NOT** allow the stem of the thermostat to rotate as you turn the screw.
- Open the door and turn the **POWER SWITCH** to the **COOL DOWN** position. This will allow the oven fan to come on without the burners and cool off the oven. Allow the oven to cool to about 250°F (120°C).
- Return the **POWER SWITCH** to the **ON** position and repeat the previous steps until the oven thermostat and the pyrometer (thermometer) reading agree.
- Replace the knob and tighten the setscrews.

CAUTION: Maximum turn of screw "A" is 1-1/2 turns - clockwise or counter-clockwise.

This thermostat is a direct-acting (opens on temperature rise) device.

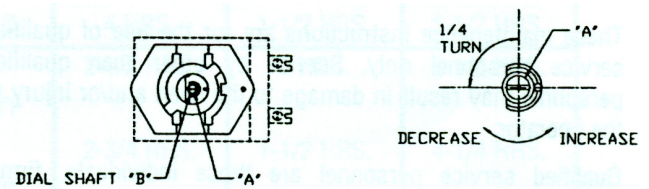

E. Cleaning of the Ovens

The stainless steel on your oven can be kept clean with a good stainless steel cleaner, many of which are on the market. The painted surfaces should be wiped clean regularly with a MILD detergent. Moisten a cloth and wipe down the oven while it is COLD. Wiping down an oven while it is hot will cause streaking and otherwise unsatisfactory results. Once the oven is clean it can be wiped down with light oil.

Porcelain oven interiors should be cleaned regularly using a degreasing agent. For heavier deposits a commercial oven cleaner such as Dow Oven Cleaner, Easy-Off, or Mr. Muscle can be used. Care must be taken to prevent these alkaline-type cleaners from coming in contact with any aluminized steel surfaces in the oven, including the blower wheel.

The blower wheel, racks and rack supports can be removed and soaked in a solution of ammonia and water.

Make certain that all parts are thoroughly rinsed before returning to use.

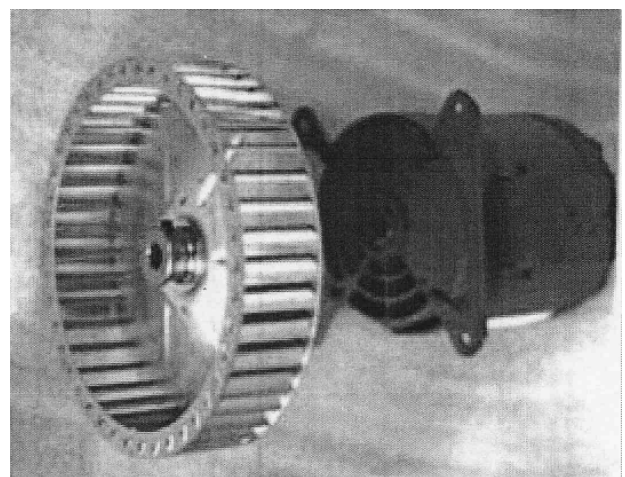

Blower Wheel

**6/13 – Electric Convection Oven
Repair Parts List**

Part #	Description	Part #	Description
153164	Baffle, 6/13 porcelain	153138	Mylar panel, "Z" model, 12-button
153738	Baffle, 6/13, stainless steel	153140	Mylar, lower, electric
153056	Bearing, door hinge	153482	Mylar panel, "ZX" model
153093	Blower wheel, 9-3/8" x 2"	153177	Probe, "X", "XX", "Z", "ZX" models
153233	Bracket, stacking (for double sections)	154379	Probe, temp, "ZZ"
154075	Buzzer, 208/240v	153229	Rack, support
153416	Catch, door	153230	Rack, oven (standard depth)
153234	Chain, door	153231	Rack, oven (deep depth)
153156	Contactora, 3-pole, 50 amp, 208/240v	153776	Relay, fan, 208-240v, "X" model
153157	Contactora, 3-pole, 30 amp, 208/240v	153108	Rod, connecting – short
153159	Contactora, 2-pole, 60 amp, 208/240v	153107	Rod, connecting – long
153499	Control, digital time/temp, "X", 2-button	153235	Rod, door-stop
153564	Control, "XX"	147963	Socket, Lamp
153150	Control, digital cook/event, "Z", 12-button	153144	Switch, 2-speed fan (opt.)
153481	Control, "ZX"	153146	Switch, interior lights (opt.)
155378	Control, "ZZ"	512289	Switch, power, "ZZ" model
154377	Control, Interface Control Board, "ZZ"	153460	Switch, rotary
153440	Door, assembly, left 50/50, solid	149403	Thermostat, (Q & V models)
153441	Door, assembly, right, 50/50, solid	512971	Timer, 60 minute, 220V, 60Hz
153434	Door, assembly, left, 50/50, w/glass	512972	Timer, 60 minute, 230V, 50Hz
153442	Door, assembly, right, 50/50, w/glass	153358	Transformer, 240/480V, 1KVA
153462	Door, assembly, left, 65/35, w/glass	154452	Transformer, "ZZ"
153285	Door, right, 65/35	147753	Turnbuckle
153461	Door, left solid, 65/35	153088	Window, oven door
153237	Door chain & turnbuckle assembly	153074	Flue Extension
153432	Door handle assembly, 50/50	153233	Stacking Bracket
153433	Door handle assembly, 65/35		
153102	Element, 10KW, 208v		
153103	Element, 10KW, 240v		
153104	Element, 10KW, 480v		
153201	Fuse, 10 amp delay		
153200	Fuse holder		
153083	Gasket, door – side (2 required)		
153084	Gasket, door – top	600131	Kit, Repl. 613EXX, C.P. W/L/2SP
153085	Gasket, door – bottom	600132	Kit, Repl. 613EXX, C.P. W/L/1SP
153115	Grommet, silicone, temp. bulb/probe	600133	Kit, Repl. 613EXX, C.P. W/O/L/2SP
153766	Knob, "X", digital	600134	Kit, Repl. 613EXX, C.P. W/O/L/1SP
153142	Knob, "V", "X", "XX", "Z", "ZX" models		
153143	Knob, digital control, "Z", "ZX" models		
156029	Bulb, Light 40 watt, 130v		
153801	Latch, roller assembly		
153204	Light, oven ready, 208/240v		
145274	Master Link, Chain		
153114	Micro Switch, door		
153071	Micro Switch, actuator		
153036	Motor, ½ HP, 2-speed, 208/240v		
153134	Mylar panel, "V" model, 2-button		
153758	Mylar panel, "X" model		
153566	Mylar panel, "XX" model		

NOTE: 153499 Control "X" is no longer available. One of the following replacement kits must be ordered.

600131	Kit, Repl. 613EXX, C.P. W/L/2SP
600132	Kit, Repl. 613EXX, C.P. W/L/1SP
600133	Kit, Repl. 613EXX, C.P. W/O/L/2SP
600134	Kit, Repl. 613EXX, C.P. W/O/L/1SP

6/13 Door Assembly (typical)

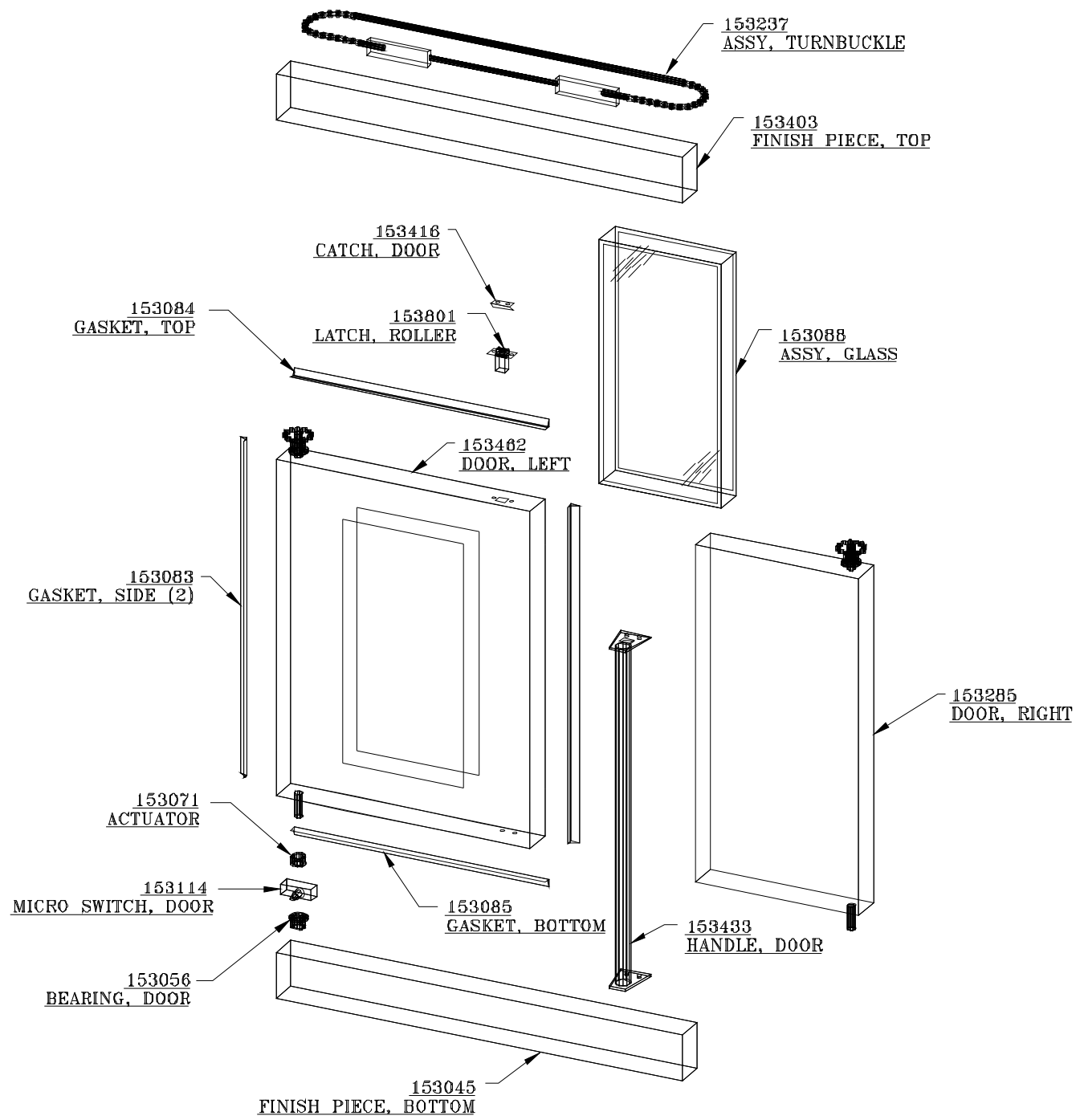

MOUNTING FLUE EXTENSION TO TOP OVEN.

- 1.) Remove existing flue trim from the top of oven.
- 2.) Insert flue extension thru top opening 1st and then align holes on flue extension with holes on rear panel of oven.
- 3.) Use 6 of the 8 screws 10-24x1/2" hex washer head that are provided to attach the flue extension to the rear panel of the oven as shown in figure. The other 2 screws are extra's and are not used.
- 4.) Re-install the existing flue trim.

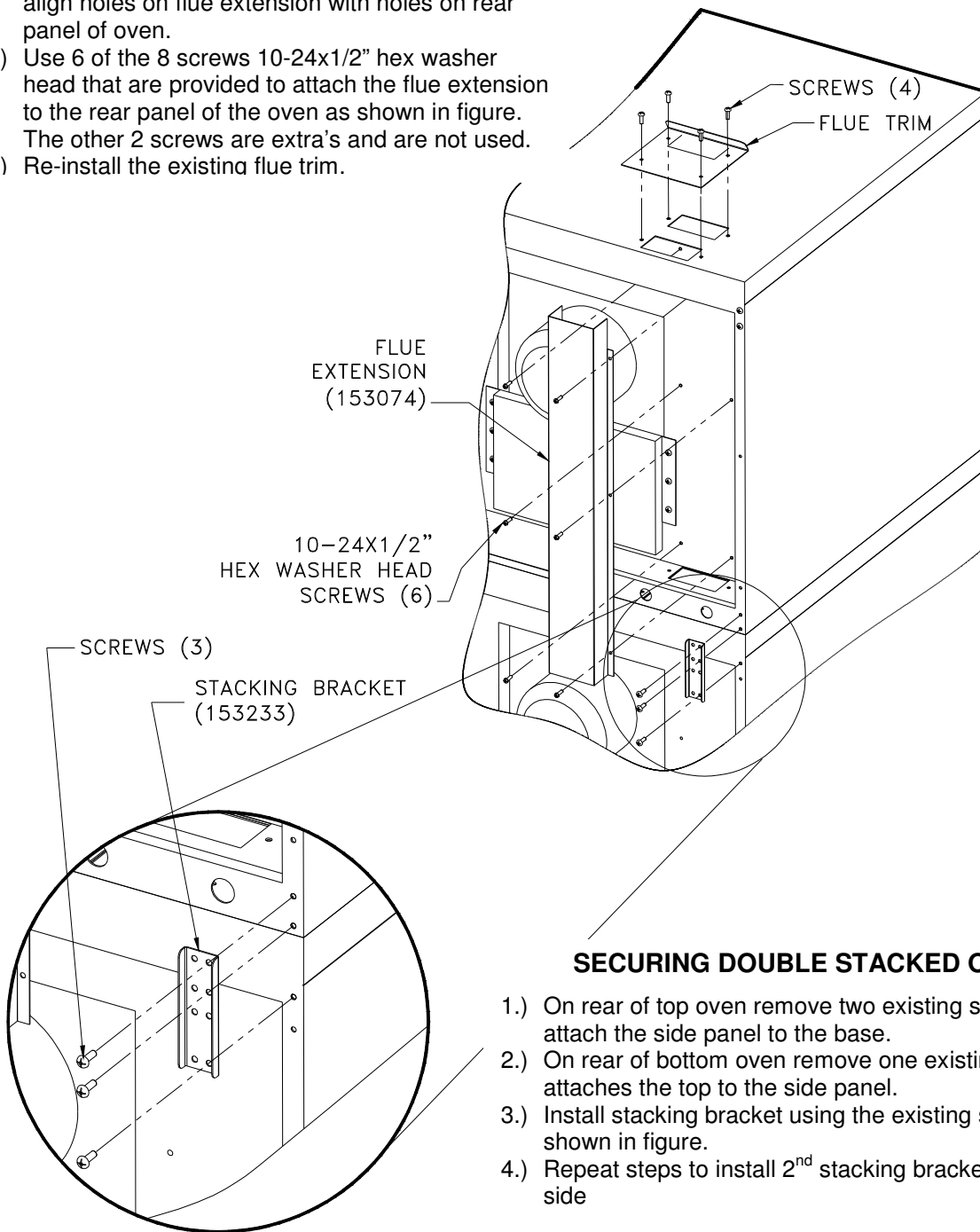

SECURING DOUBLE STACKED OVENS

- 1.) On rear of top oven remove two existing screws that attach the side panel to the base.
- 2.) On rear of bottom oven remove one existing screw that attaches the top to the side panel.
- 3.) Install stacking bracket using the existing screws as shown in figure.
- 4.) Repeat steps to install 2nd stacking bracket on other side

"6/13 "V" Controller Assembly

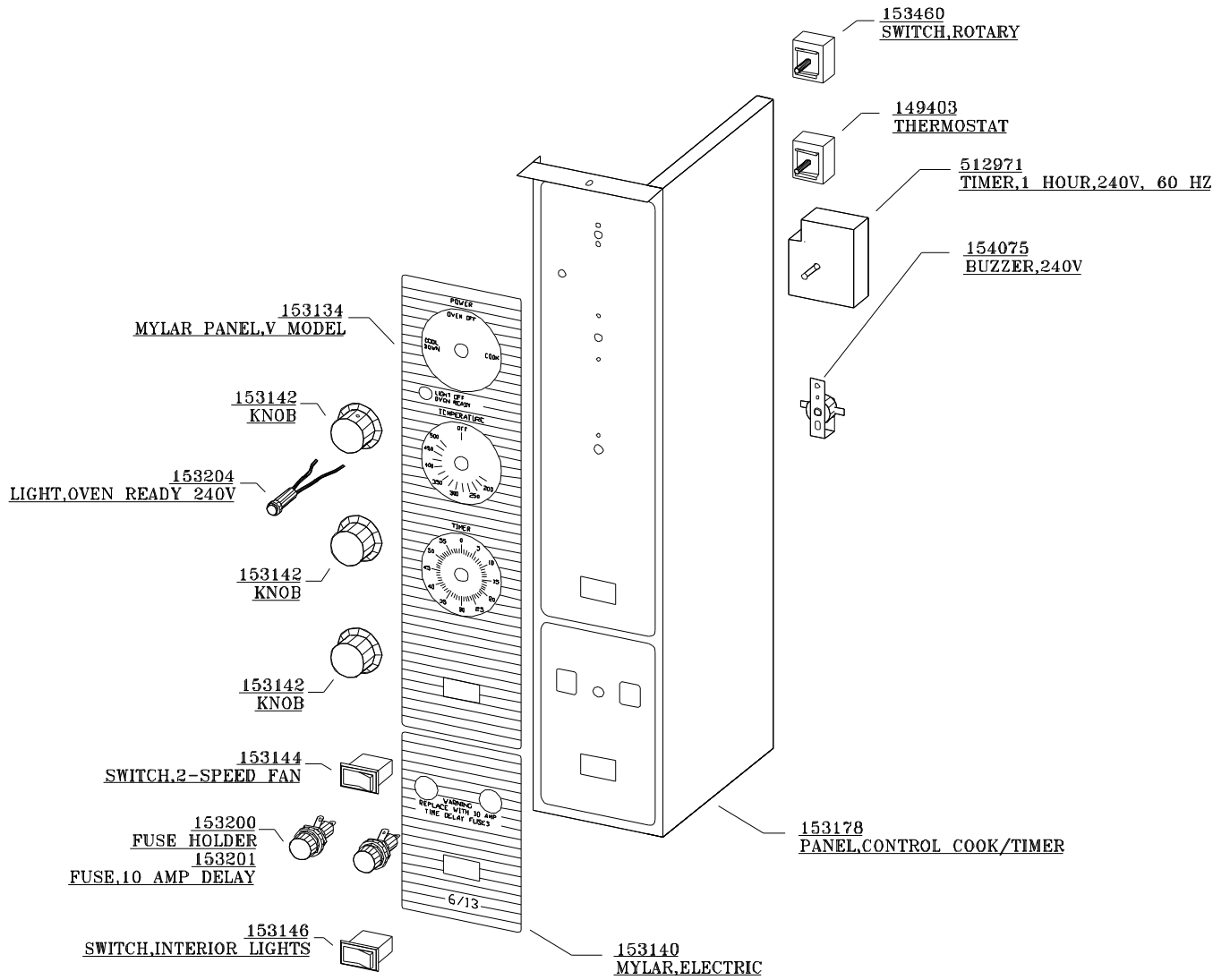

6/13 "X" Controller Assembly

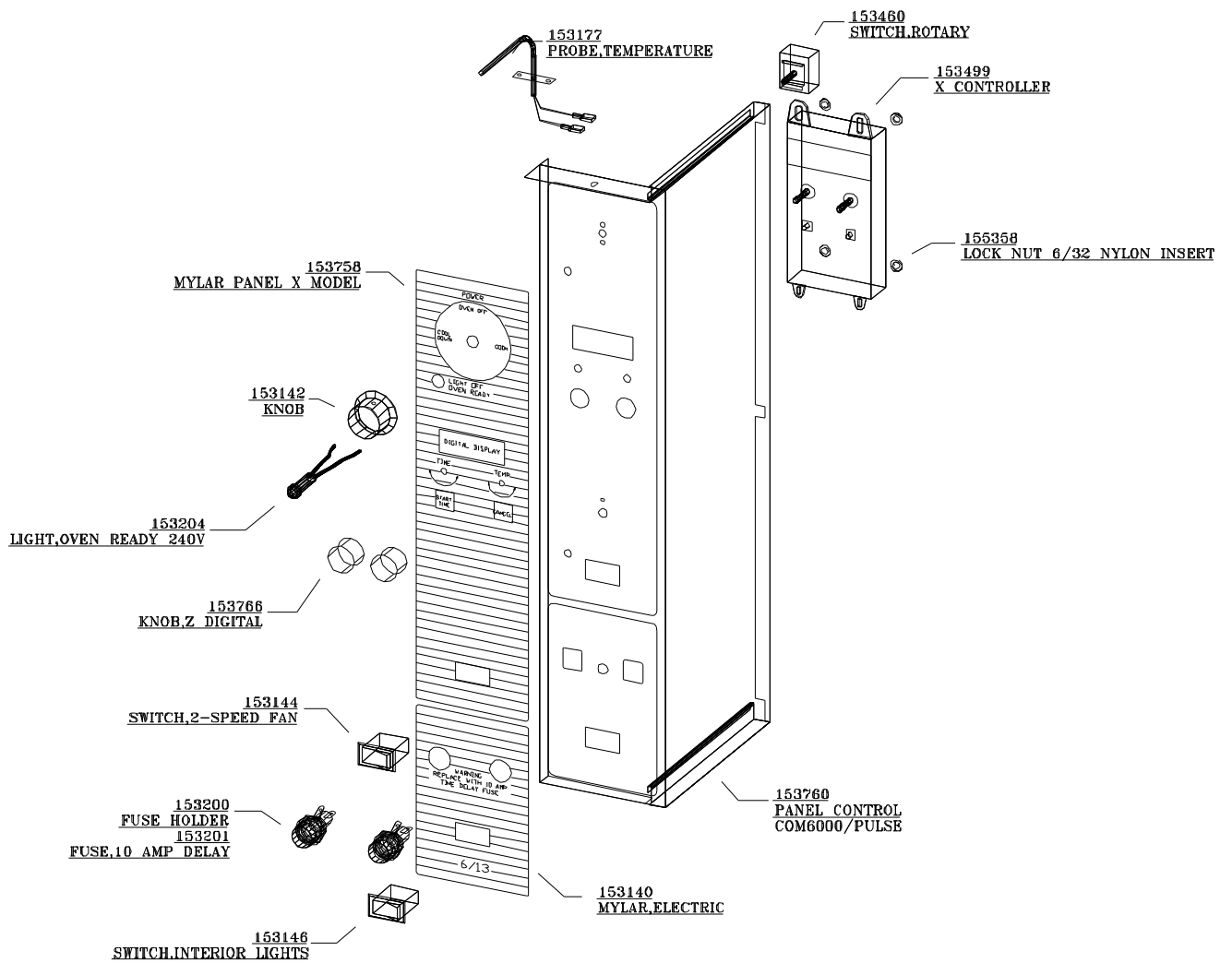

6/13 "Z" CONTROLLER ASSEMBLY

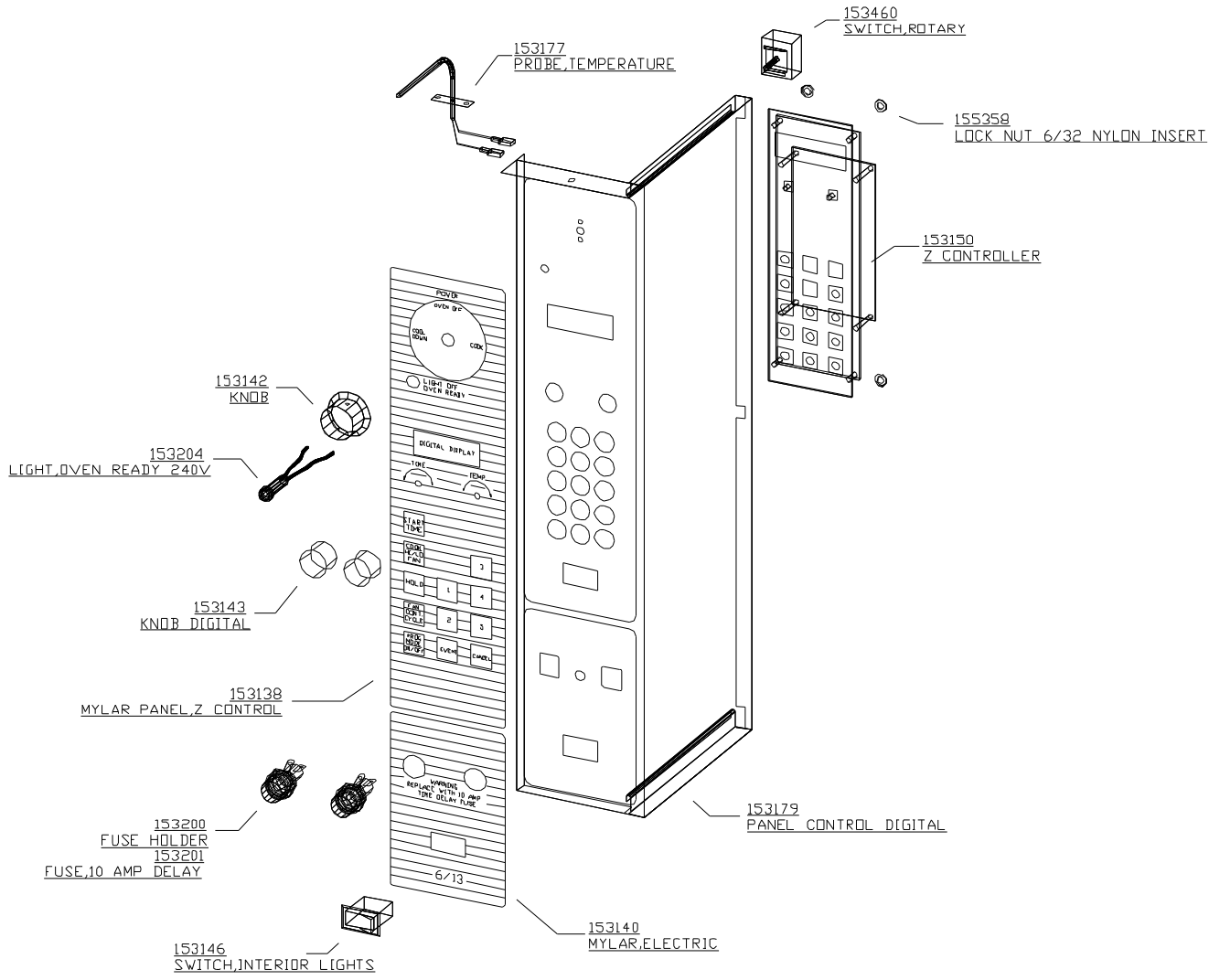

6/13 "ZX Controller Assembly

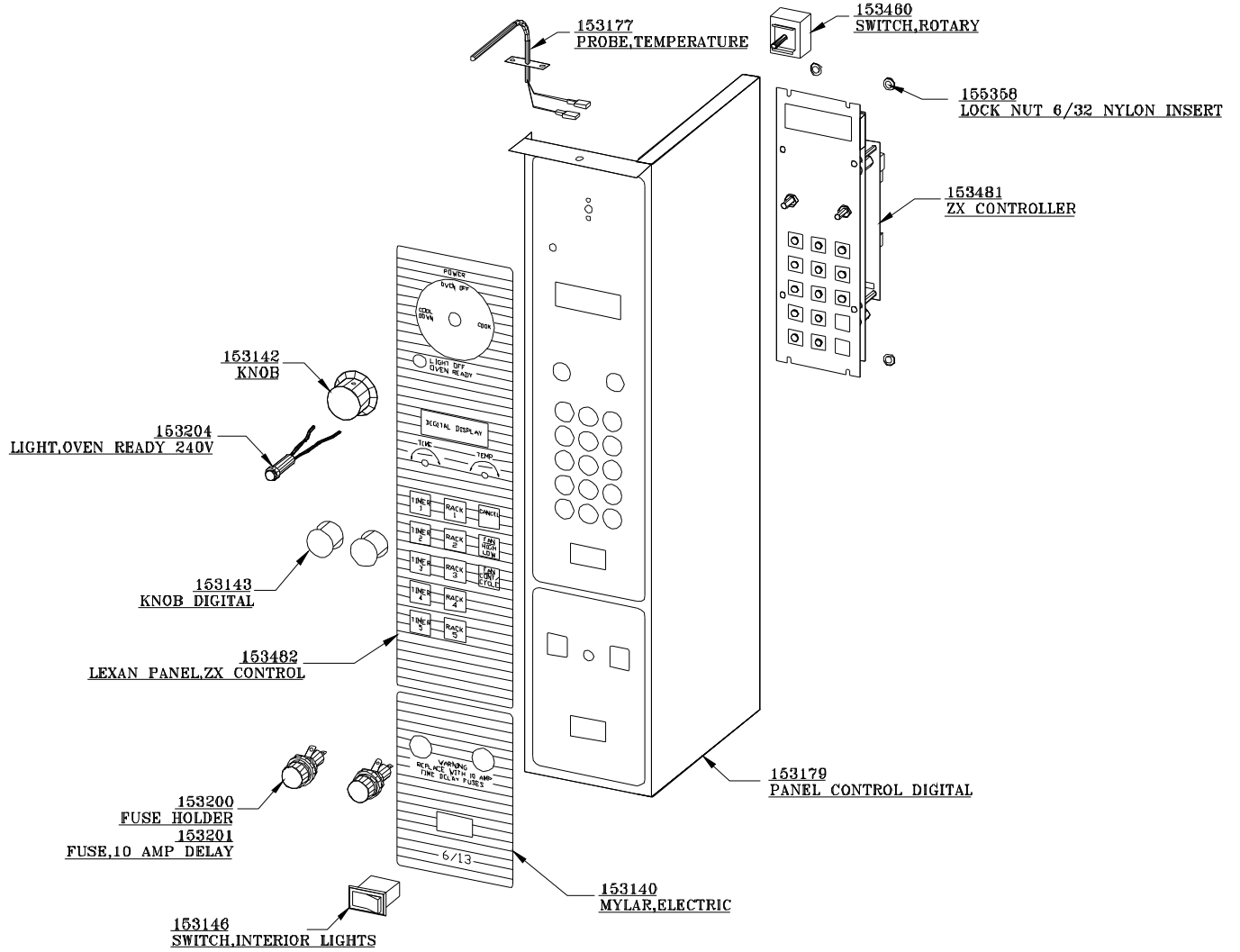

613 "XX" Controller Assembly

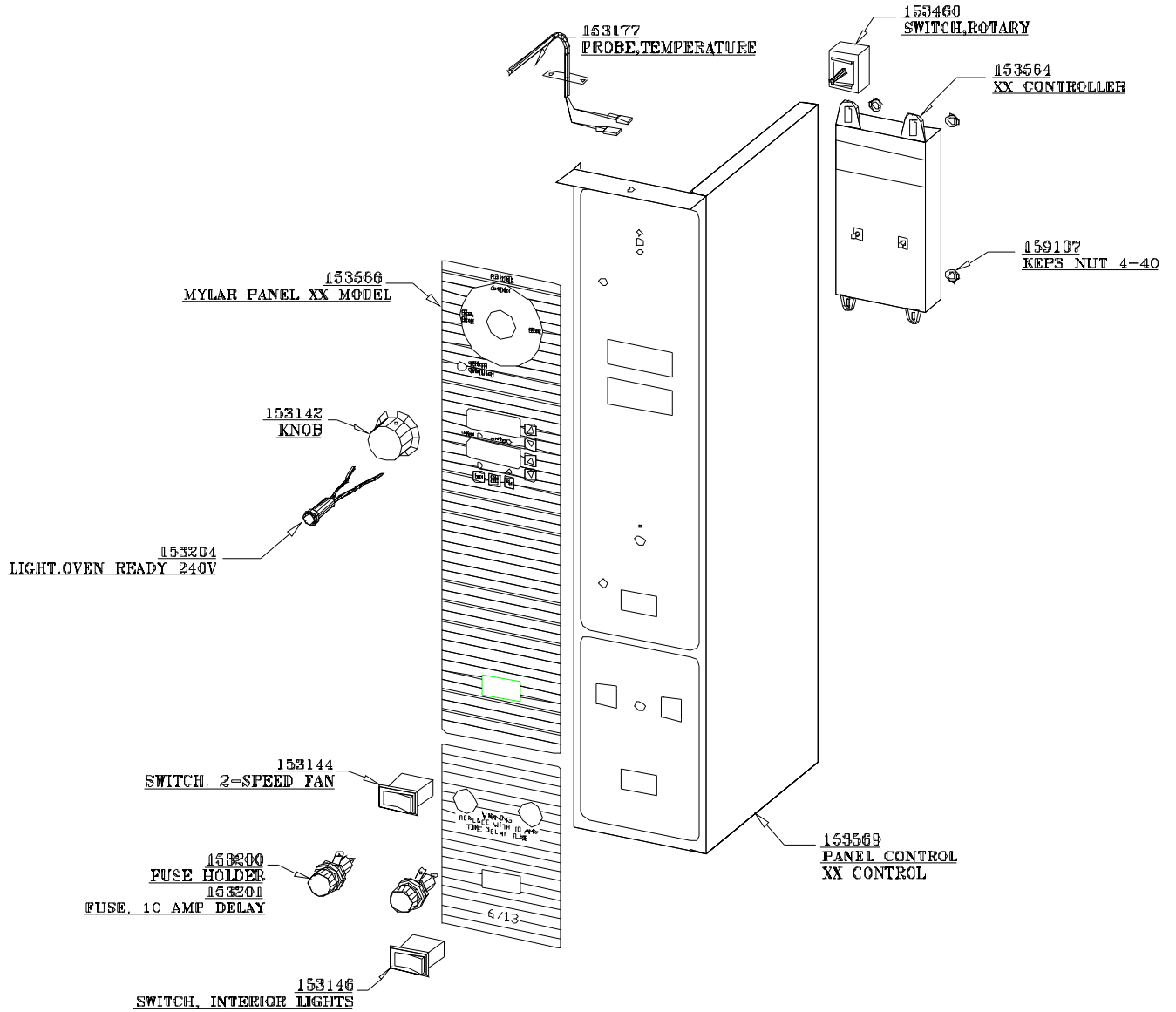

6/13 Contactor Identification

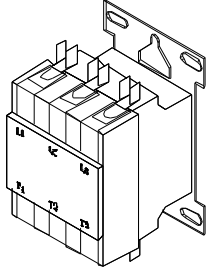

153156
CONTACTOR, 50AMP

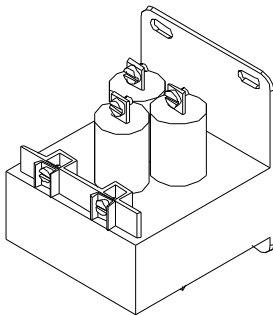

153157
CONTACTOR, 30AMP

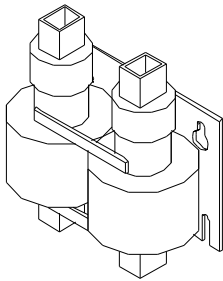

153159
CONTACTOR, 60AMP

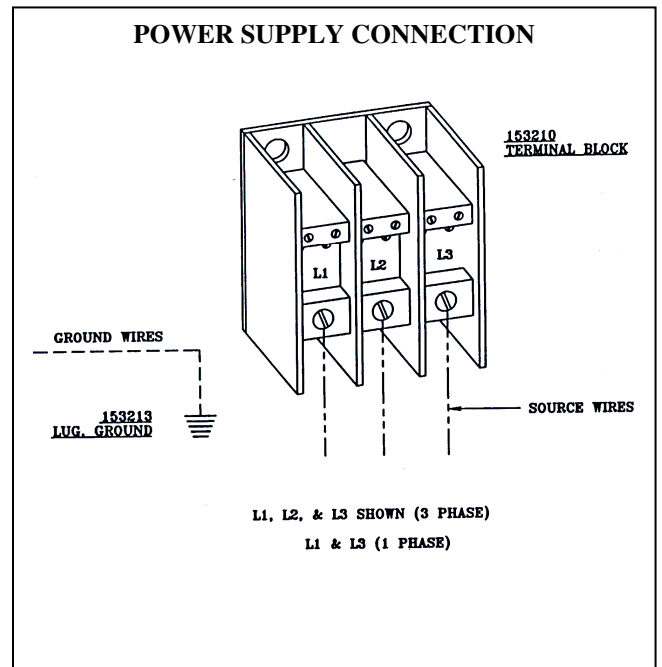

"V" CONTROLLER

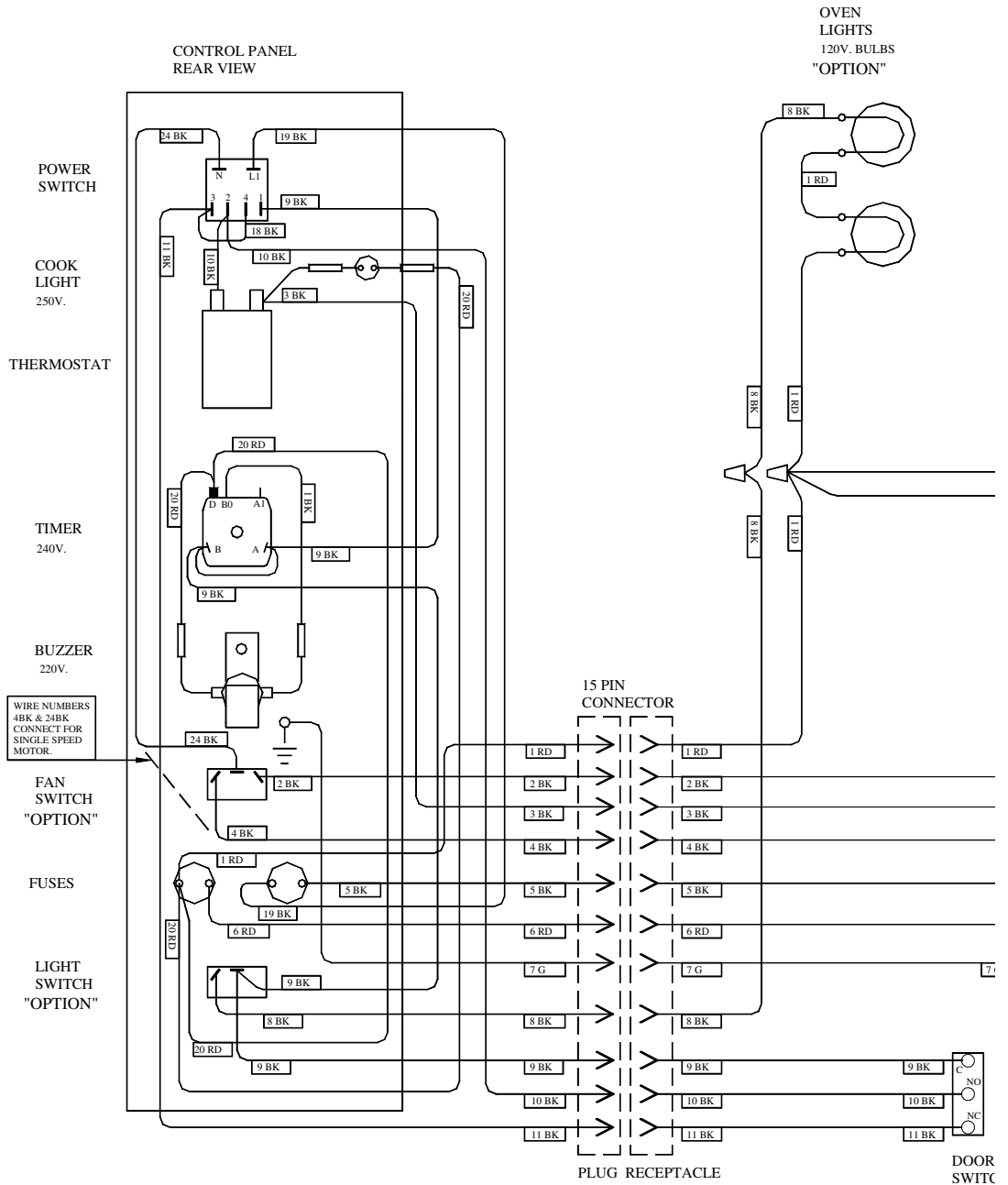

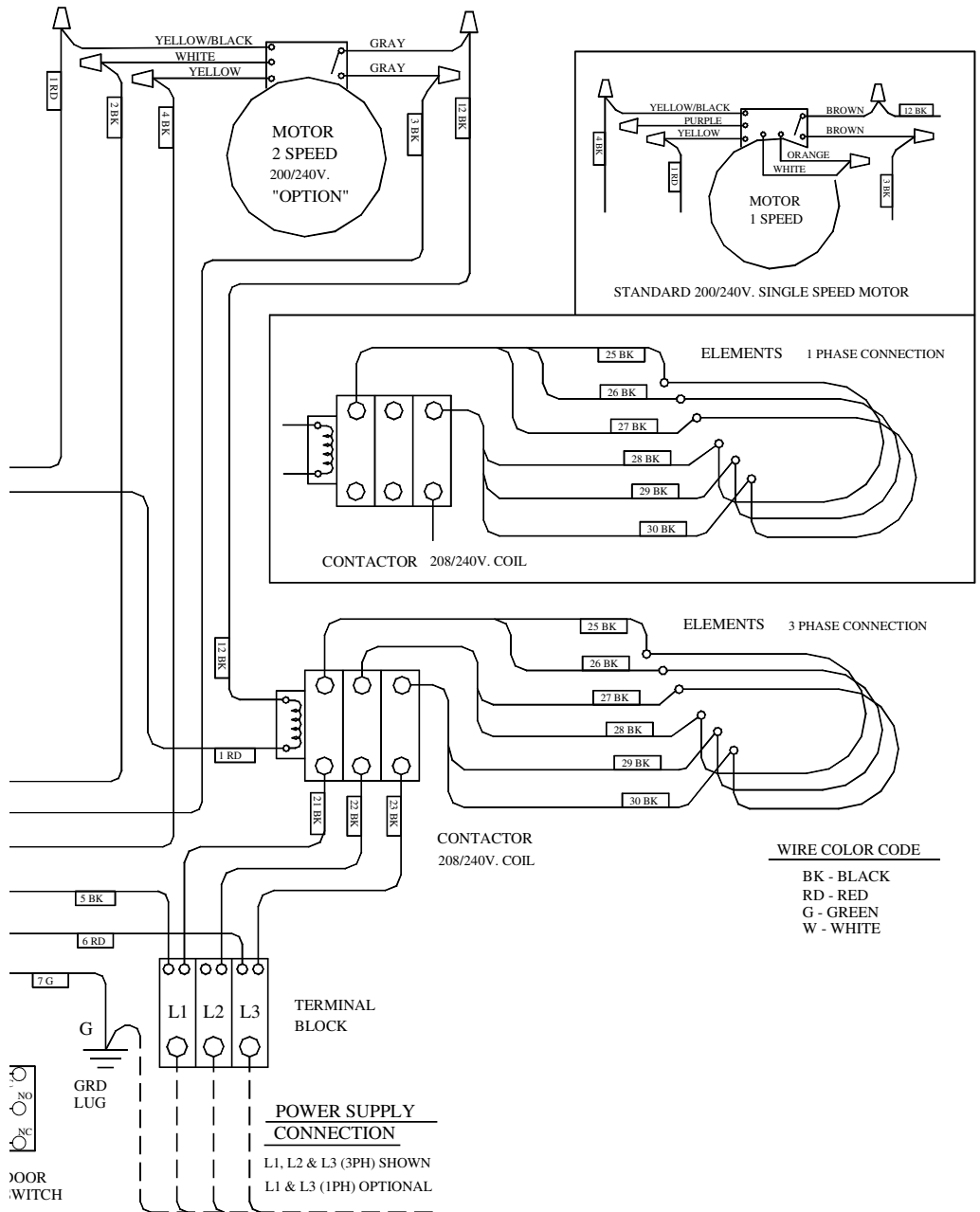

W153620 Rev. C

"X" CONTROLLER

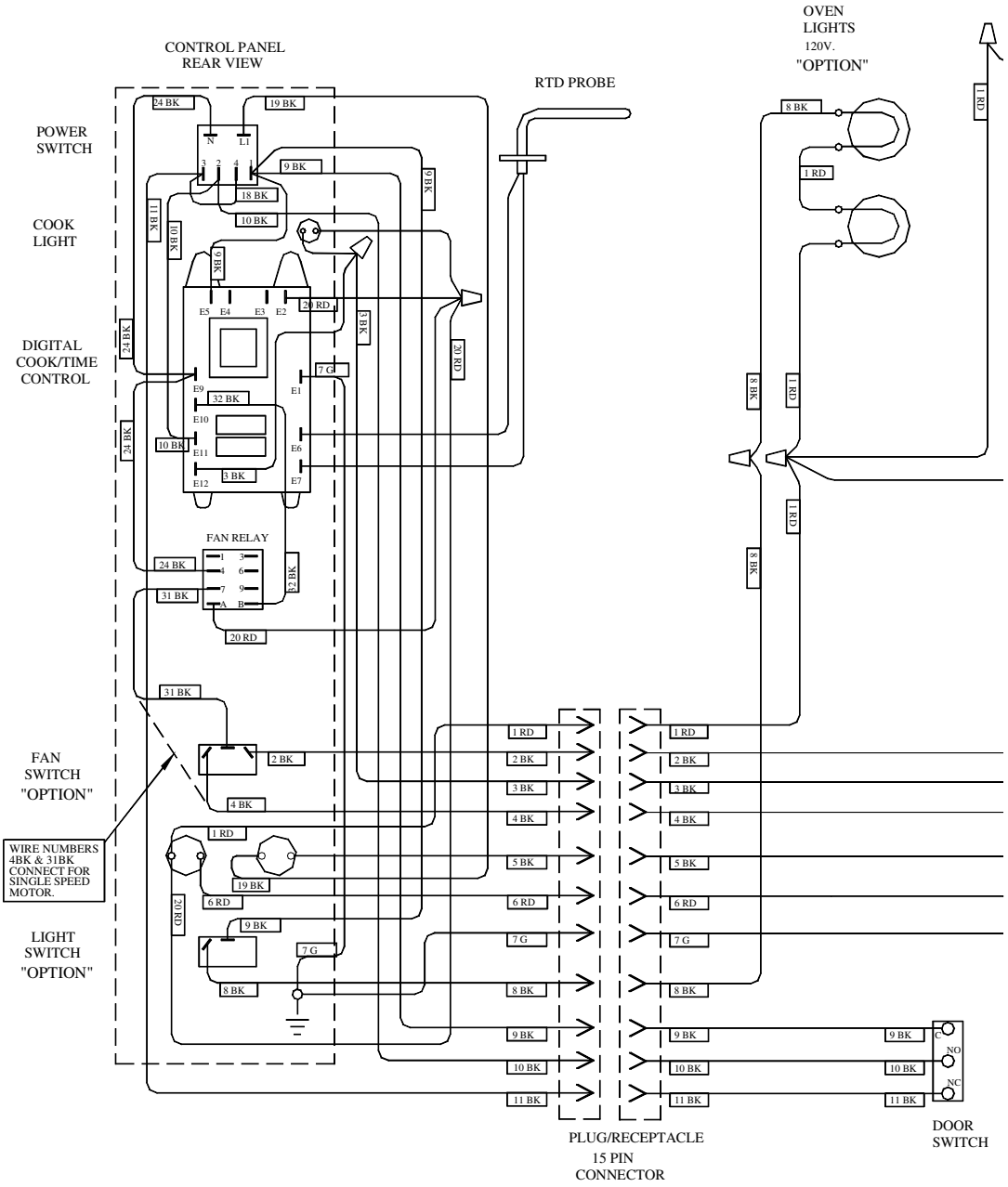

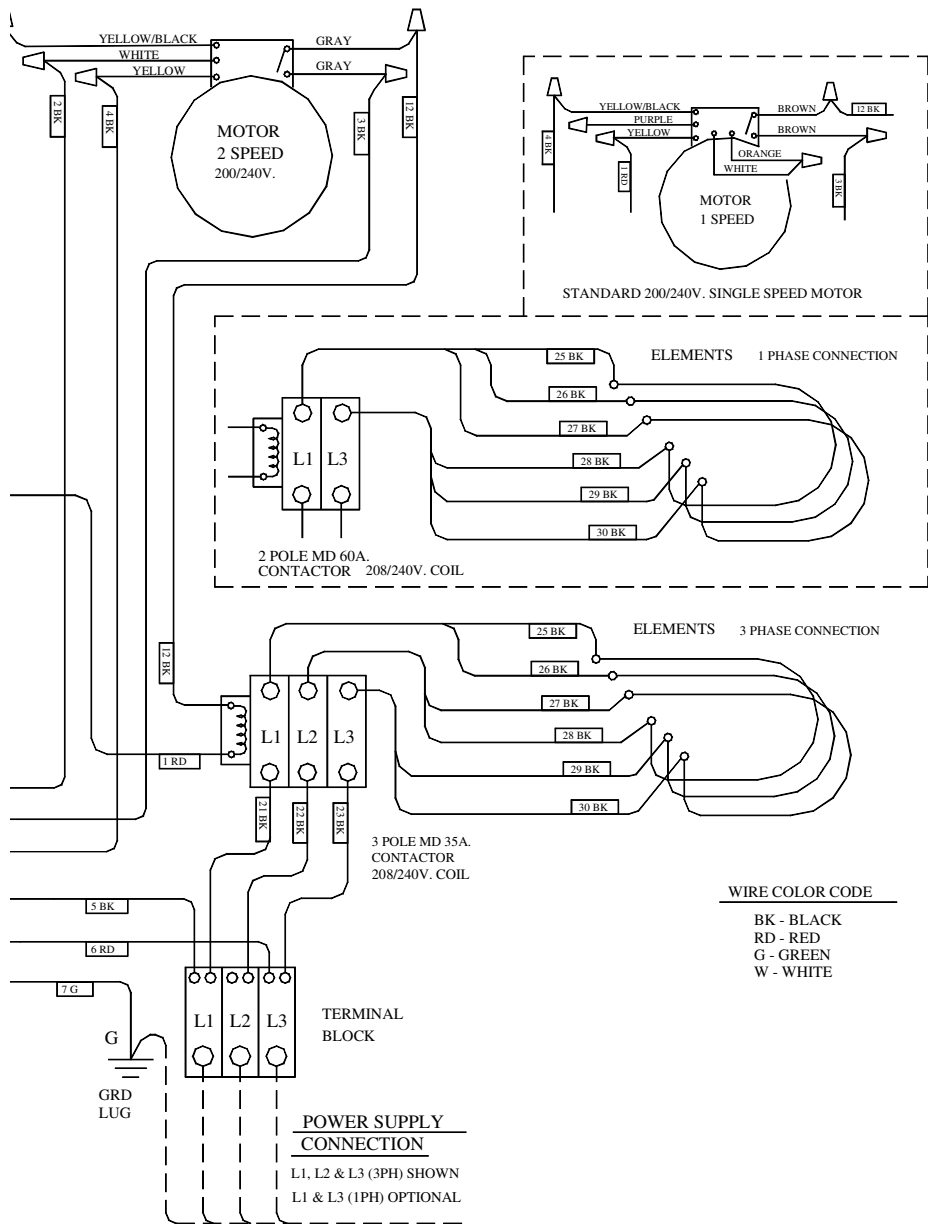

W153621 REV. C

“Z” & “ZX” Controller

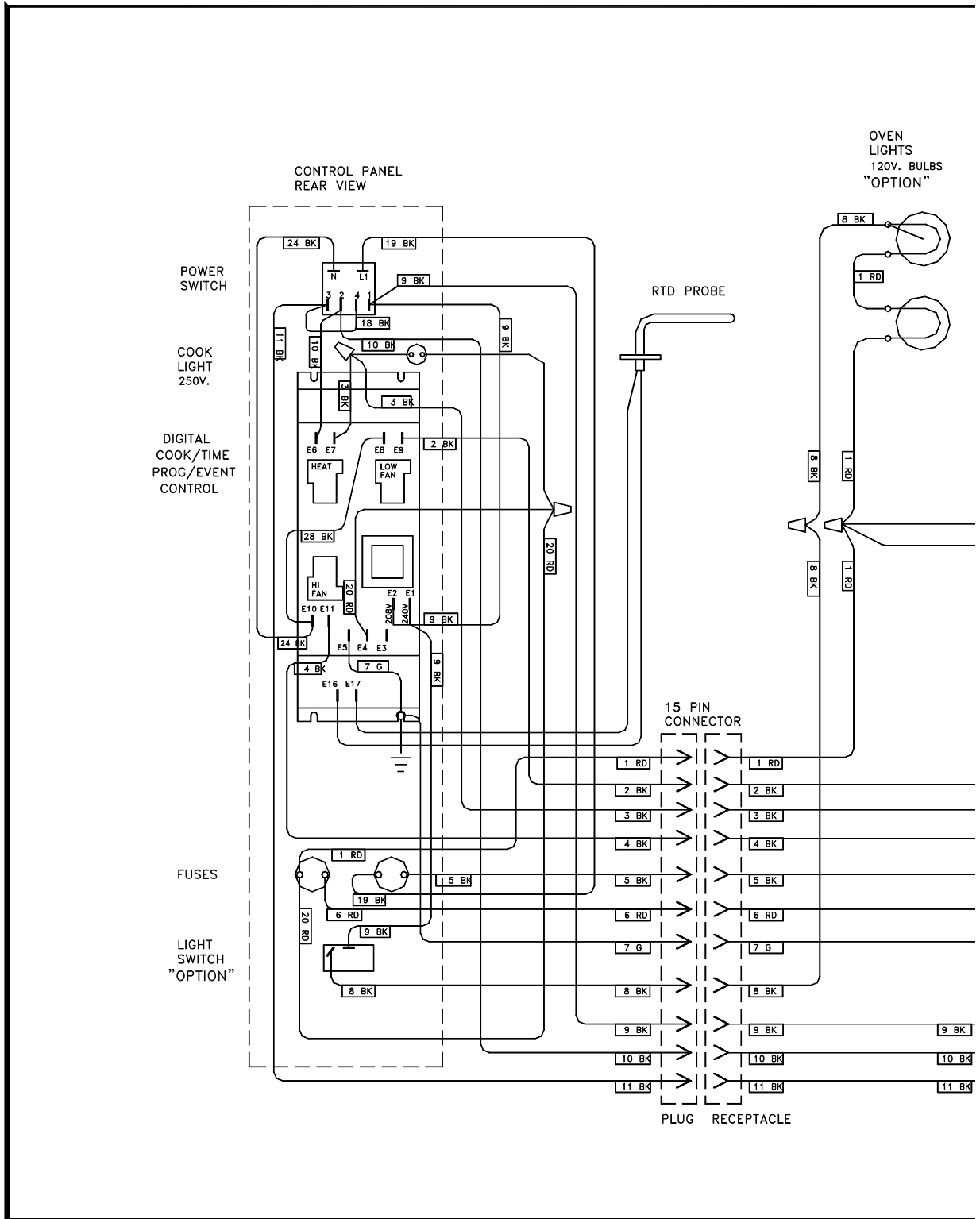

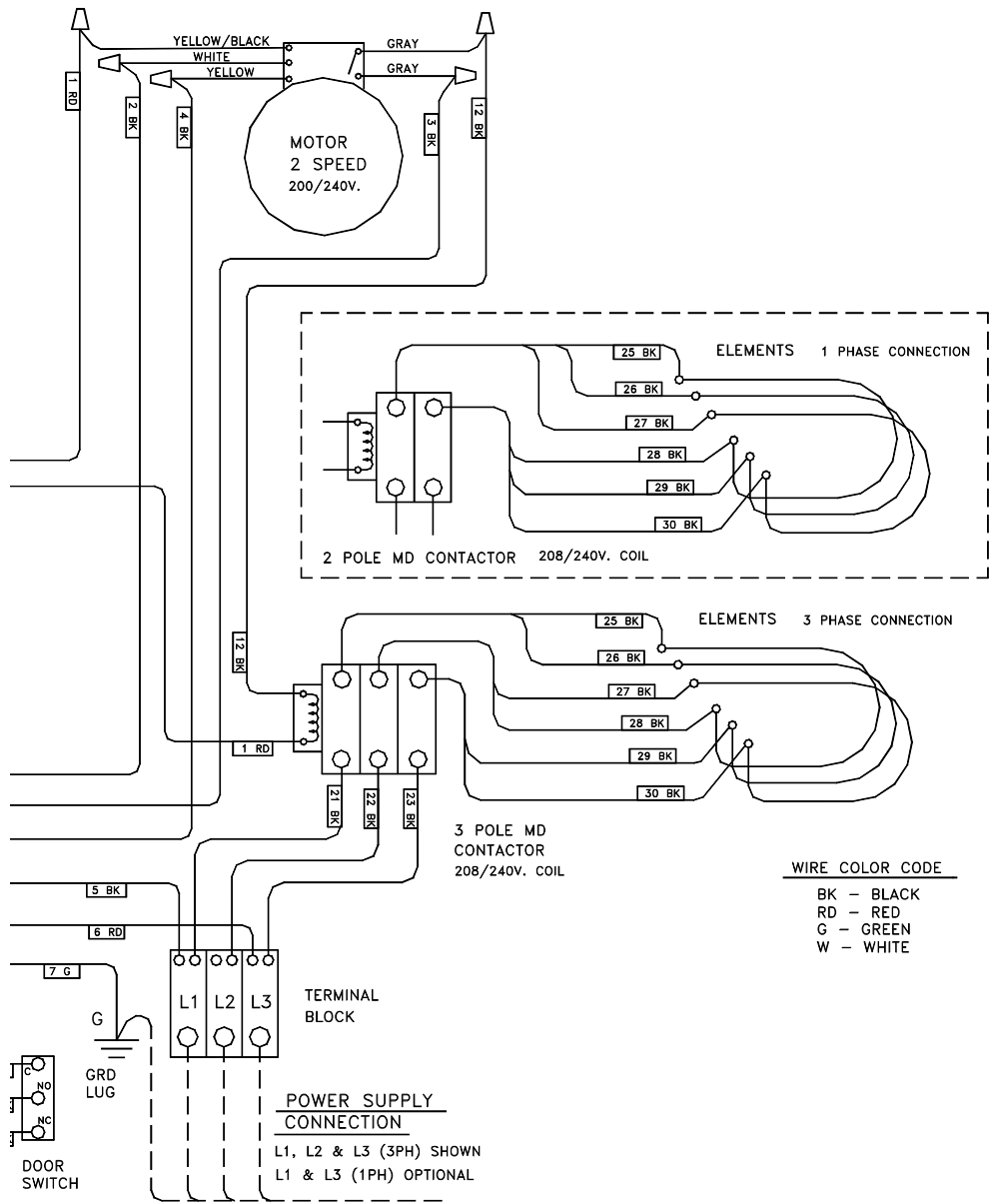

W153622 REV. C

“XX” Electric Control Wiring Schematic

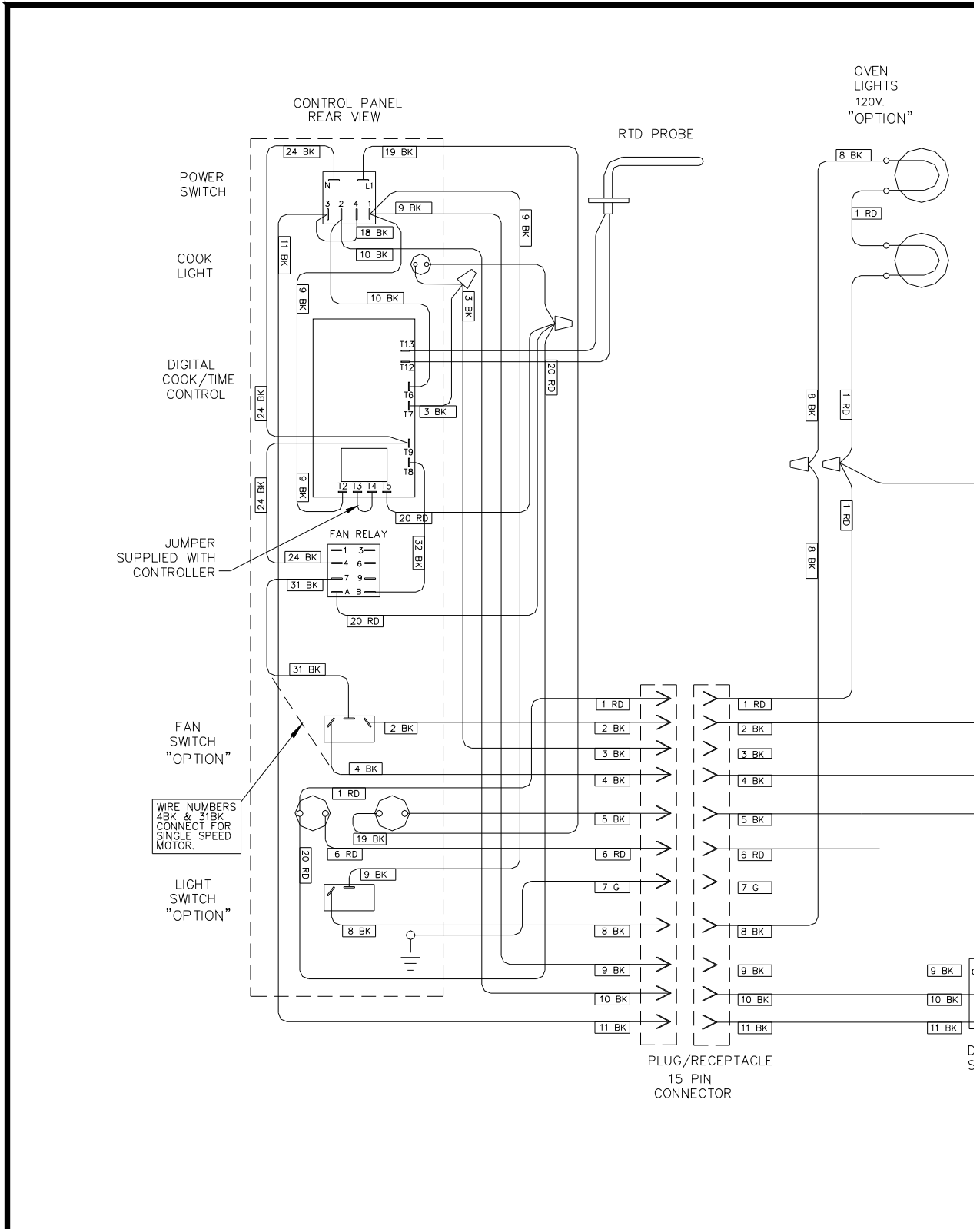

REV	ECO NO.	DATE	BY	DESCRIPTION
A	04243	11/11/04	GKS	RELEASED TO PRODUCTION

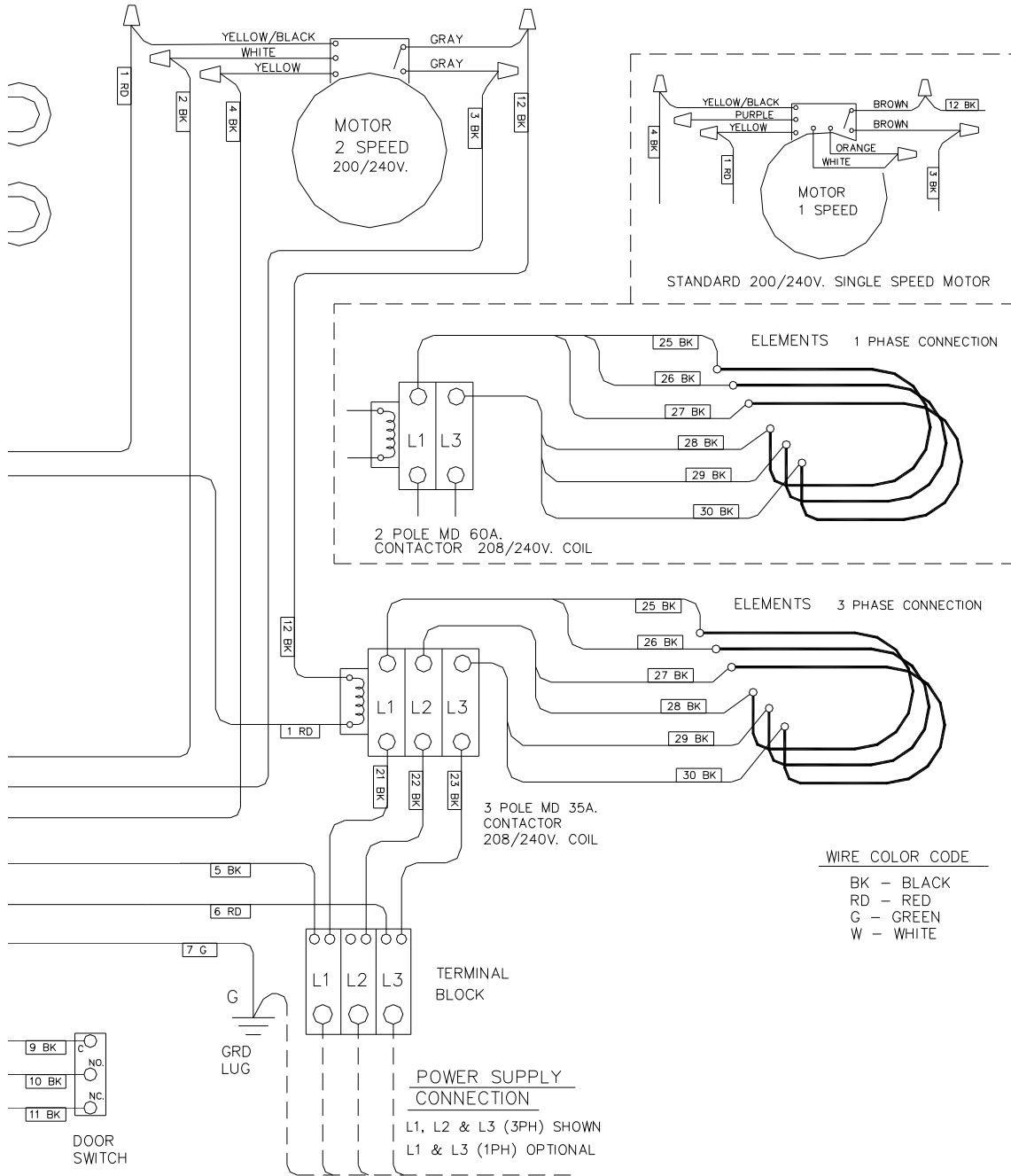

DUKE MANUFACTURING CO.				
MAT'L: -	TOLERANCE UNLESS NOTED: ± .031 INCHES ± 1 DEGREE	DESCRIPTION: DIAGRAM WIRE 6/13 ELEC "XX", 208/240 V		
MAT'L P/N: -	DRAWN BY: G.K.SWANSON	DATE: 11/11/04		
FINISH: -	CHECKED BY: -	DATE: -	SCALE NONE	DRAWING NUMBER: 153572W

“ZZ” 208/240 MOTOR/ELEMENT SIDE

