"E" Series

ELECTRIC CONVECTION OVEN



Installation, Operation, Parts & Maintenance Manual



"Your Solutions Partner"

DUKE MANUFACTURING CO.
2305 N. Broadway • St. Louis, MO 63102
800.735.3853 • 314.231.1130 • 314.231.5074 Fax
www.dukemfg.com

153431K

INDEX

	PAGE
"E" Series Electric Specification	3
Installation Instructions	
A. Qualified Personnel	4
B. Delivery & Inspection	4
C. Location of Oven	4
D. Electrical Connections	5
E. Ventilation	5
F. Oven Assembly	5
G Adjustments Associated with Installation	6
Operating Instructions	
A. Oven Controls	7
B. General Guidelines for Operation	8
C. Suggested Times & Temperatures	9
D. Cleaning the Oven	10
Maintenance Instructions	
A. Adjustments	10
B. Door Switch Adjustment	10
C. Thermostat Calibration	11
Repair Parts List	12
Double Stacked Ovens	13
Wiring Diagram	14-15

Please supply the ID Number and the Serial Number when ordering replacement parts or requesting service.

We recommend service by Duke Authorized Service Agencies during and after the warranty period.

POST IN A PROMINENT LOCATION instructions to be followed in the event the user smells gas. This information shall be obtained by consulting the local gas supplier.

FOR YOUR SAFETY:

Do not store gasoline or other flammable vapors or liquids in the vicinity of this or any other appliance.

WARNING:

Improper installation, adjustment, alteration, service or maintenance can cause property damage, injury or death. Read the installation, operating and maintenance instructions thoroughly before installing or servicing this equipment.

“E” SERIES ELECTRIC CONVECTION OVEN

Electrical Specifications

TOTAL KW	VOLTS	1 PHASE	3 PHASE
10 KW	208	53	31
10 KW	240	46	27
10 KW	220/380		20
10 KW	240/415		18
10 KW	480		14

INSTALLATION INSTRUCTIONS:

A. Qualified Personnel

These installation instructions are for the use of qualified installation and service personnel only. Installation or service by other than qualified personnel may result in damage to the oven and/or injury to the operator.

Qualified installation personnel are those individuals, firms, companies or corporations which either in person or through an agent are engaged in and responsible for:

- The installation of electrical wiring from the electric meter, main control box or service outlet to the electrical appliance. Qualified installation personnel must be familiar with all precautions required and have complied with all requirements of state and local authorities having jurisdiction. See: National Electrical Code, ANSI/NFPA70-1990.

B. Delivery and Inspection

Duke Manufacturing Co. does everything within its power to insure you received your oven in good condition. They are strapped down on heavy wooden skids and surrounded by heavy "tri-wall" cartons to prevent shipping damage. They have all been carefully inspected before they were packaged and consigned to the carrier.

Upon delivery of your Duke oven:

- Look over the shipping container, carefully noting any exterior damage on the delivery receipt which must also be signed by the driver/delivery person.
- **Uncrate** and check for any damage which was not evident on the outside of the shipping container. This is called concealed damage. The carrier must be notified within **fifteen** (15) days of the delivery of the oven and the carton, skid and all packaging materials must be retained for inspection.

Duke Manufacturing Co. cannot assume liability for loss or damage suffered in transit. The carrier assumes full responsibility for delivery in good order when the

shipment was accepted. However, we are prepared to assist you in **filing** your claim.

C. Location of the Oven

Proper planning and placement of the oven will give you the best results in terms of long term user convenience and satisfactory performance. We urge you to give adequate thought in the placement of your oven prior to its arrival.

- The oven should be placed in an area which is free from drafts and accessible for proper operation and servicing.

- The area around the oven must be kept clear of combustible materials. A **minimum** clearance of:

	Combustible	Non-Combustible
RIGHT SIDE	1"	0"
LEFT SIDE	1"	0"
REAR	3"	3"
FLOOR	8"	8"

must be maintained between the oven and any combustible or non-combustible surface

It is also important not to obstruct the natural flow of ventilation air if the oven is to operate properly. This oven should not be installed on a curb base or sealed to the wall. Either condition can restrict the flow of air to or prevent proper ventilation of the blower motor. The blower motor has a thermal protection device which will trip because of excessive ambient temperatures at the back of the oven. This condition should be corrected immediately to avoid damaging the oven permanently.

Before making any connections to the oven, check the rating plate to be sure the oven specifications concur with the voltage and phase to be supplied to the oven

The rating plate is located behind the lower front panel. To access, loosen the four screws below the doors, and pull the panel outward.

The plate bearing the oven's serial number is located on the right of the oven, below the control panel.

D. Electrical Connections

Your oven is supplied for connection to a 208, 240 or 480 volt grounded circuit. The electric motor, oven lights, indicator lights and control circuits are connected internally and require no secondary power supply

Before making any connections to these units, check the rating plate to assure that the voltage and phase of the oven is compatible with the electrical supply. When installing, all ovens must be electrically grounded in accordance with local codes, or in the absence of local codes, with the National Electrical Code, [ANSI/NSPA 70-1990](#) (in Canada - [CSA Std. C-22.1](#)). Wiring diagrams are located in the control compartment area of the oven and at the back of the oven. Standard wiring schematics are also provided with this manual.

NOTE TO ELECTRICAL INSPECTOR:

Inspection of electrical connection should be accomplished by the removal of the lower finishing piece. This is done by loosening the four screws located in the door opening under the doors.

E. Ventilation

Proper ventilation is very important for the proper function of your oven. A good ventilation system will allow the oven to function properly as well as remove unwanted vapors. Not venting the ovens properly can result in unsatisfactory baking results as well as the possibility of damaging your oven. To keep your warranty in force, a proper ventilation system must be employed.

Venting to a Canopy Exhaust Hood

The best way to vent your oven is by placing it under a properly designed mechanically driven exhaust hood. The hood should be sized so the equipment which it is designed to ventilate fits underneath with a minimum six (6) inch (152 mm) overhang on all sides not adjacent to a wall. The distance from the floor to the lower edge of the canopy should not exceed seven (7) feet (2.2 m).

The hood should have adequate capacity and provide a sufficient supply of make up air. Ventilation hoods come in many sizes and capacities. Hood capacity is expressed in cubic feet per minute (CFM). The total make-up and exhaust air required for the canopy hood should be about 22 CFM per oven section. Information for the proper construction and installation of ventilating hoods may be obtained from the "Standard for the Installation of Equipment for the Removal of Smoke and Grease-Laden Vapors from Commercial

Cooking Equipment, [NFPA-96-1980](#)".

F. Oven Assembly

Before assembling and installing the oven, please check to make sure that all necessary parts are present. In addition to the oven itself, there will also be legs, feet or casters, the vent guard, (for double sections, retaining clips vent riser) and miscellaneous hardware. Please check the interior of all oven sections for the parts needed to assemble and install your oven(s).

Leg Attachment

- Once the oven has been removed from the carton, lay it on its left side (the side without the controls), hold the leg and align with the threaded holes in the front corner of the bottom of the oven. Carefully start the threads of the corner leg bolt (5/16"-18 X 1/2"), avoid cross threading.
- Align the leg plate holes in each leg with those in the corners of the oven bottom and secure using two 5/16"-18 x 1/2" bolts. Tighten all bolts firmly. Repeat this procedure for all legs.
- Raise the oven up on its legs.

Level the oven by turning the adjustable feet in or out as needed.

Caster Installation

- Casters are available as an option for both the single and double oven sections.
- The installation of casters requires the removal of the adjustable feet from the legs. This is done by placing the bit of a large screwdriver against the lip of the foot and rapping the screwdriver to drive the foot out of the leg. The caster is then inserted fully into the opening where the foot came out and the locking nut tightened to expand the compression sleeve of the caster.

NOTE: The casters with locking brakes are best mounted on the front side of the oven for easier access.

If you plan to use casters, a fixed restraint of the proper length is recommended to eliminate strain on the connecting wire. If the oven is removed from its normal position, the restraint must then be reattached when returned.

Double Sections

- Secure the short legs to the bottom of the lower section as described in previous section.
- If supplied with casters, secure them as described in the section for caster installation..
- Place upper section on top of lower section and align all edges of the ovens.
- Locate securing clips and place in slots at rear of oven sectin, tighten..
- Install the vent connector by sliding it over the lower oven sections vent then over the upper oven's vent.
- Attach with the sevevs provided.

WARNING: The proper installation of the vent connector is important to avoid high ambient temperatures at the rear of the ovens. High ambient temperautres can cause premature blowere motor failure.

G. Adjustments Associated with Installation

Each oven section and all its component parts have been tested thoroughly and inspected before your oven was shipped from the factory. However, it is sometimes necessary to further test or adjust the oven once it has been installed. Such adjustments are the responsibility of the Dealer or Installer. These types of adjustments are not considered defects, rather a normal and routine part of the proper installation of the equipment.

These adjustments include but are not limited to:

- Adjustments and **recalibration** of the thermostat
- Adjustment to the doors.
- Leveling.
- Tightening of fasteners.

No installation should be considered complete without proper inspection and, if necessary, any adjustments by qualified service or installation personnel.

OPERATION INSTRUCTIONS

The information in this section is intended for the use of qualified operating personnel. Qualified Operating Personnel are those individuals who have carefully read the information contained in this manual, are familiar with the function of the oven and/or have had experience with operating the equipment described. We recommend following these instructions to insure optimum performance, long life and trouble-free service from your oven.

The "E" Series of Convection Ovens

Convection cooking has been around from the 1960s. Its advantages are well known. It differs from conventional cooking by the movement of heated air within the cooking cavity by means of a fan. This moving, heated air helps to strip the cool air from around the product being cooked, allowing the heat to penetrate more rapidly. The results are that your product is cooked quicker and at a lower temperature with the comparable product quality found in conventional ovens.

Please take the time to carefully read the operating instructions. They are important in the successful use of your "E" Series oven.

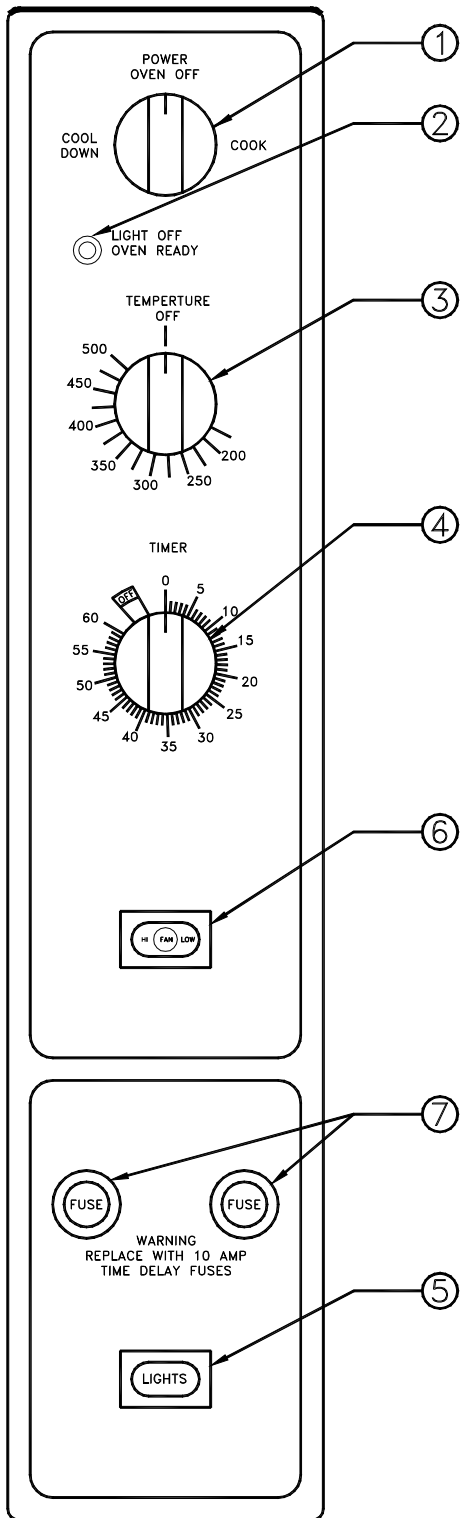

A. Oven Controls — Electro-Mechanical

- **1. The Power Switch** - Controls power to ON or Cool Down Function.
- **2. The Indicator Light** - When lit indicates elements are operating. When the light goes out, the oven has reached its cooking temperature.
- **3. The Cooking Thermostat** - Controls the oven temperature.
- **4. The Cooking Timer** - Sounds an electric buzzer on expiration of operator set time as a reminder to remove product at end of cooking cycle.
- **5. The Light Switch (Optional)** - Controls interior lights.
- **6. The Fan Speed Switch (Optional)** - Sets fan speed to high or low.
- **7. The Fuse Holders** – Contain circuit protecting fuses.

B. General Guidelines for Operation

These guidelines are to assist you in obtaining the best performance from your oven:

- Always **pre-heat** your oven before cooking in it by placing the temperature setting at the desired temperature. The oven is **pre-heated** when the Indicator Light goes out.
- Always use a lower temperature setting than that recommended for a standard conventional oven or range oven. The general rule of thumb is to subtract 50 - 100°F from the standard oven recipe. Some experimentation on your part may be necessary to achieve the optimum results with your food products.

Cooking at higher temperatures will not reduce your cooking time! It will produce unsatisfactory baking and roasting results.

- You should begin checking the **doneness** of your food product in about half the time recommended for the same recipe cooked in a standard oven. There is a Suggested Time and Temperature Chart on the next page which can serve as a guide. Keep in mind that your times may vary depending on the amount of product being cooked in your oven. The best results are always achieved when a systematic record of times and temperatures is kept for reference.
- The oven will hold up to thirteen 18" x 26" (457mm x 660mm) sheet pans. Five racks are used normally, but your product and pan height will determine how many racks can be loaded.

Do not place an empty sheet pan or aluminum foil on the bottom of the oven. This will disrupt the air flow and cause uneven cooking results.

- To minimize the shrinkage of roasted meats, place the meat directly on the racks and place a sheet pan one half full of water in the bottom rack position. The water will keep the oven compartment more humid and the meat juices will evaporate less.

- Maintain equal loads when cooking more than one pan of product at a time. You may wish to weigh the product to assure that the pan loads are equal. Smaller loads in one pan will cook at a different rate than larger ones in another.
- You may wish to experiment with leaving the oven OFF after **pre-heating** the oven and loading when baking light products such as light cake batter or custard so the product will have time to set. Normally, 7-10 minutes with the oven OFF, then finishing with the oven ON, will keep the product from rippling or being pushed by the fan.
- When starting off with frozen product, you may wish to pre-heat your oven up to 100°F above the temperature you are going to cook. Load the product and reset the temperature for the normal time.
- For longer bulb life, do not leave the oven lights on when not viewing the product.

C. Suggested Times & Temperatures

	PRODUCT	°F	°C	COOK TIME	RACKS	TEMP	TIME
BEEF	HAMBURGER FWTIES (3.3 OZ.)	400	205	8-10 MIN.	13		
	MEAT LOAF	325	165	40-45 MIN.	4		
	STEAMSHIP ROUND (80 LBS. QUART.)	275	135	2-3/4 HRS. F	2		
	ROLLED BEEF ROAST (12-15 LBS.)	275	135	2-1/2 HRS.	4		
	STANDING RIB ROAST (20 LBS. RARE)	235	115	2-3/4 HRS.	2		
	SHELL STEAKS (100Z.)	450	235	7-8 MIN.	6		
	POT PIES	400	205	30-35 MIN.	6		
	STUFFED PEPPERS	350	175	15-20 MIN.	4		
	LASAGNA	260	125	90 MIN.	4		
	HOT DOGS	325	165	10-15 MIN.	6		
PORK	BAKED, STUFFED PORK CHOPS	375	190	25-30 MIN.	6		
VEAL	BONED VEAL ROAST (15 LBS.)	300	150	3 HRS. 10 MIN.	3		
LAMB	LAMB CHOPS	400	205	7-8 MIN.	6		
	BACON	400	205	5-7 MIN.	13		
POULTRY	CHICKEN BREASTS & THIGHS	350	175	40 MIN.	6		
	CHICKEN BACKS SWINGS	350	175	35 MIN.	6		
	CHICKEN, QUARTERED	350	175	30 MIN.	6		
	TURKEY ROLL (18 LB.)	310	155	3-3/4 HRS.	4		
	POT PIES	400	205	30-35 MIN.	6		
FISH	FISH STICKS	335	170	16-18 MIN.	13		
SEAFOOD	COD, HALIBUT (FROZEN)	350	175	20 MIN.	6		
	SHRIMP BAKED STUFFED	400	205	6-7 MIN.	6		
	LOBSTER, BAKED STUFFED	400	205	10 MIN.	4		
	LOBSTER TAILS (FROZEN)	425	220	9 MIN.	6		
CHEESE	MACARONI & CHEESE CASSEROLE	350	175	30 MIN.	6		
	CHEESE SANDWICHES, GRILLED	400	205	8 MIN.	13		
POTATOES	POTATOES, BAKED (120 COUNT)	400	205	50 MIN.	6		
	POTATOES, SLICED OR DICED	325	165	10 MIN.	6		
	FRENCH FRIES (FROZEN)	TIMES & TEMPS WILL VARY AS TO CUT					
PIES	FROZEN BERRY PIES (36 - 22 OZ. EA.)	325	150	35 MIN.	6		
	FROZEN FRUIT PIES (24 - 46 OZ. EA.)	325	150	45-50 MIN.	6		
	FRESH APPLE PIE (36 - 20 OZ. EA.)	350	175	25-30 MIN.	6		
	PUMPKIN PIE	300	150	30-50 MIN.	6		
	FRUIT CRISP	300	150	25 MIN.	6		
	FRUIT COBBLER	300	150	30 MIN.	6		
	APPLE TURNOVERS	350	175	15 MIN.	6		
BREADS	BREAD (32 - 1 LB. LOAVES)	325	160	30 MIN.	4		
	CORN BREAK (NORTHERN)	325	160	25 MIN.	6		
	CORN BREAD (SOUTHERN)	375	190	15-20 MIN.	6		
	HAMBURGER ROLLS	275	125	15 MIN.	6		
	YEAST ROLLS	300	140	25 MIN.	6		
	BISCUITS	400	205	6 MIN.	6		
	ROLLS, BROWN & SERVE	350	175	15 MIN.	6		
CAKES	SHEET CAKES (5 LBS. BATTER PERPAN)	325	160	16-18 MIN.	6		
COOKIES	CHOCOLATE CAKE	325	160	20 MIN.	6		
	BROWNIES	325	150	15 MIN.	6		
	DANISH FASTRY	325	160	12 MIN.	6		
	CINNAMON BUNS	325	160	20 MIN.	6		
	SUGAR COOKIES	275	125	15 MIN.	13		
	CREAM PUFFS	325	160	20-25 MIN.	6		
	CHOCOLATE CHIP COOKIES	325	160	10 MIN.	13		
	PEANUT BUTTER COOKIES	300	150	10 MIN.	13		

NOTE: Your times and temperatures may vary from those shown on this **chart**. Your results depend on weight per pan, temperature of the product before **loading**, the recipe, type of pan, and calibration of the thermostat. If your recipes vary from these, write in your proven times and temperatures for your future use.

D. Cleaning of the Ovens

The stainless steel on your oven can be kept clean with a good stainless steel cleaner, many of which are on the market. The painted surfaces should be wiped clean regularly with a MILD detergent. Moisten a cloth and wipe down the oven while it is COLD. Wiping down an oven while it is hot will cause streaking and otherwise unsatisfactory results. Once the oven is clean it can be wiped down with a light oil.

Porcelain oven interiors should be cleaned regularly using a degreasing agent. For heavier deposits a commercial oven cleaner such as Dow Oven Cleaner, Easy-Off, or Mr. Muscle can be used. Care must be taken to prevent these alkaline-type cleaners from coming in contact with any aluminized steel surfaces in the oven, including the blower wheel.

The blower wheel, racks and rack supports can be removed and soaked in a solution of ammonia and water.

Make certain that all parts are thoroughly rinsed before returning to use.

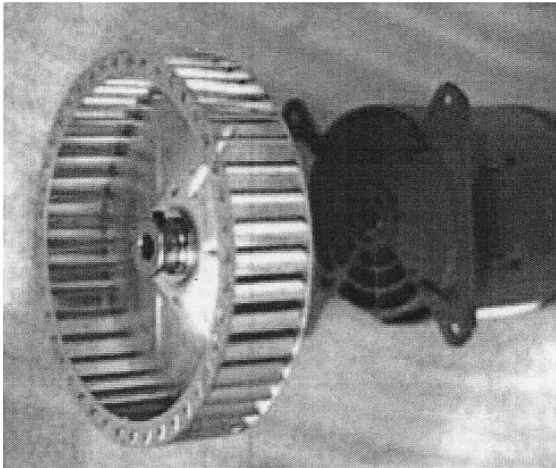

Blower Wheel

MAINTENANCE INSTRUCTIONS

These maintenance instructions are for the use of qualified service personnel only. Service by other than qualified personnel may result in damage to the oven and/or injury to the operator.

Qualified service personnel are those individuals, firms, companies or corporations which either in person or through an agent are engaged in and responsible for repair or servicing of commercial

food preparation equipment, who are experienced in such work, familiar with all precautions required, and have complied with all requirements of state and local authorities having jurisdiction.

If you should require assistance in the selection of a qualified service agency, please contact Duke Manufacturing Co.'s Service Department at 800-735-3853.

Adjustments

Quite often malfunctions which are attributed to defects may be repaired by adjusting certain parts rather than replacing them.

B. Door Switch Adjustment

You may also wish to adjust the door switch. The door switch is located behind the combustion compartment cover, on the right side. The door switch is activated by a cam which is mounted to the door's hinge pin with a set screw.

- Open the doors fully.
- Remove the lower cover by removing the four screws located inside the door opening.
- Position the doors so they are nearly closed but not latched.
- To adjust the cam loosen the set screw and rotate the cam until you hear the switch click.
- Tighten the set screw in the cam. Test the door to make certain the switch will make contact with the doors closed.
- Replace the combustion cover.

CAUTION: The door switch is located in a heated zone. Care should be taken to avoid burns.

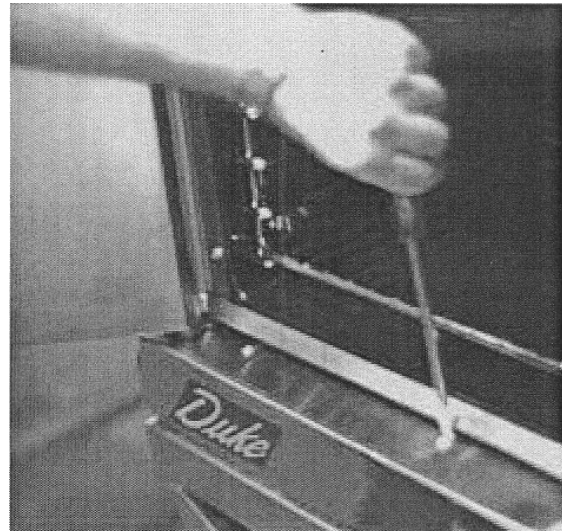

Door Switch Access Panel

C. Thermostat Calibration

In many convection ovens thermostats have been the cause of more operating problems than any other component part. Thermostats, being mechanical devices, do sometimes fail, in which case only replacing the part will correct the problem.

To Check Calibration:

- Turn the oven on by turning the Power Switch to the ON position.
- Open the doors and place a thermocouple in the center of the middle oven rack. A reliable mercury-type thermometer can be substituted if a pyrometer is not available.
- Turn the thermostat dial to 350°F (177°C). Allow the oven to preheat 1/2 hour.
- When the indicator light goes out, the thermostat has been satisfied. Check the pyrometer or thermometer to determine the internal oven temperature.
- If the reading on the pyrometer (or thermometer) is less than 10°F different from the setting of the thermostat, no adjustment is needed. If this reading is more than 10°F, proceed with calibration procedure.

However, the great majority of thermostat related problems can be attributed to their being out of adjustment (calibration). A thermostat that is out of calibration may cause unsatisfactory cooking results such as uneven baking, prolonged cooking times, etc. If you are experiencing uneven cooking, it may be a result of excessive cooking temperatures. Refer to the cooking chart provided in Operating Instructions Section C.

To Calibrate the Ovens

- Remove the thermostat knob by loosening the set screw and pull the knob forward. Take care not to rotate the thermostat stem, which will change the setting.
- With a very small screwdriver, turn the screw located in the bottom of the hollow of the stem clockwise to lower the temperature or counterclockwise to raise the temperature. DO NOT allow the stem of the thermostat to rotate as you turn the screw.
- Open the door and turn the POWER SWITCH to the COOL DOWN position. This will allow the oven fan to come on without the burners and cool off the oven. Allow the oven to cool to about 250°F (120°C).
- **Return the POWER SWITCH to the ON position** and repeat the previous steps until the oven thermostat and the pyrometer (thermometer) reading agree.
- Replace the knob and tighten the set screws.

CAUTION: Maximum turn of screw "A" is 1-1/2 turns - clockwise or counter-clockwise.

This thermostat is a direct-acting (opens or "breaks" circuit of temperature rise) device.

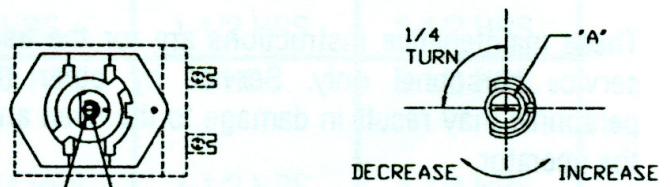

“E” Series Electric Convection Oven Repair Parts List

Part #	Description
153164	Baffle, 613, porcelain
153056	Bearing, door
153093	Blower wheel, 9-3/8" x 2"
153233	Bracket, stacking (for double sections)
156029	Bulb, Light 40 watt, 130v
154075	Buzzer, 208-240v
153416	Catch, door
153156	Contact, 3-pole, 50 amp, 208/240v
153440	Door, assembly, 6/13, solid, left, 50/50
153441	Door, assembly, 6/13, solid, right, 50/50
153434	Door, assembly, 6/13, w/glass, left, 50/50
153442	Door, assembly, 6/13, w/glass, right, 50/50
153102	Element, 10KW, 208v
153103	Element, 10KW, 240v
153104	Element, 10KW, 480v
153200	Fuse holder
153201	Fuse, 10 amp delay
153083	Gasket, door – side (2 required), 6/13
153084	Gasket, door – top, 6/13
153085	Gasket, door – bottom 6/13
153115	Grommet, silicon, bulb/probe
153432	Handle, door, assembly, 6/13 50/50 doors
165766	Knob, "X" controller
153142	Knob, "V", "X", "Z", "ZX"
153143	Knob, "Z", "ZX" controller
153801	Latch, roller assembly
153204	Light, oven ready, 208-240v
153114	Micro Switch, door 6/13
153034	Motor, only – ½ HP, 100-115/200-230v, 1-speed
153036	Motor, only – ½ HP, 200-240v, 2-speed
155361	Mylar panel, "E" Series, "V" model
155363	Mylar, lower, electric, "E" Series
153230	Rack, 6/13 oven (standard depth)
153231	Rack, 6/13 oven deep depth
147963	Socket, lamp
153229	Support, rack, 6/13
153071	Switch, actuator, door, 6/13
153146	Switch, interior lights (opt.)
153144	Switch, 2-speed fan (opt.)
153460	Switch, rotary
149403	Thermostat, "V" model
512971	Timer, 60-minute, 220v, 60Hz
512972	Timer, 60-minute, 230v, 50Hz
153358	Transformer, 480/240v, 1KVA
153088	Window, only assembly, 6/13
153074	Flue Extension
153233	Stacking Bracket

MOUNTING FLUE EXTENSION TO TOP OVEN.

- 1.) Remove existing flue trim from the top of oven.
- 2.) Insert flue extension thru top opening 1st and then align holes on flue extension with holes on rear panel of oven.
- 3.) Use 6 of the 8 screws 10-24x1/2" hex washer head that are provided to attach the flue extension to the rear panel of the oven as shown in figure. The other 2 screws are extra's and are not used.
- 4.) Re-install the existing flue trim.

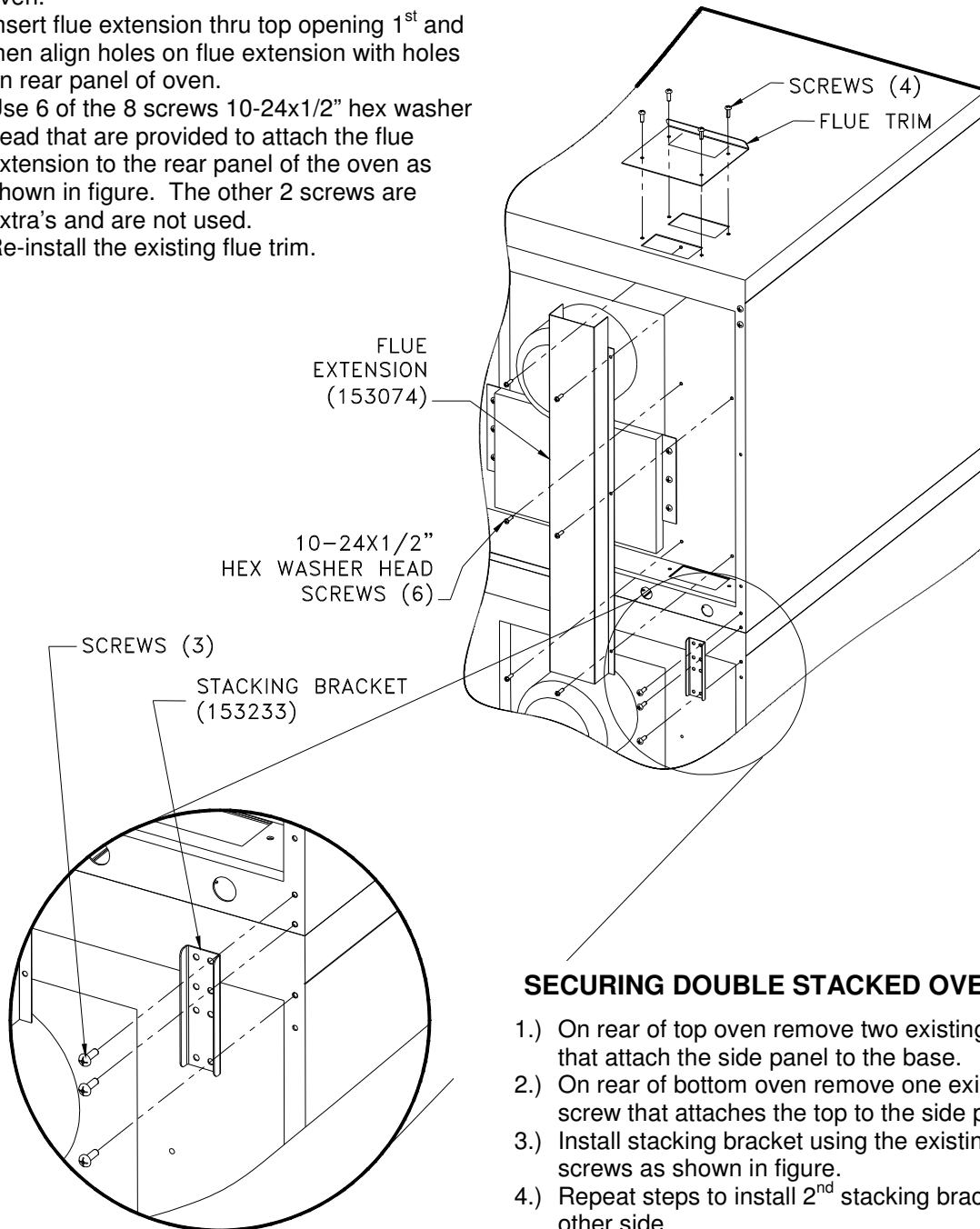

SECURING DOUBLE STACKED OVENS

- 1.) On rear of top oven remove two existing screws that attach the side panel to the base.
 - 2.) On rear of bottom oven remove one existing screw that attaches the top to the side panel.
 - 3.) Install stacking bracket using the existing screws as shown in figure.
 - 4.) Repeat steps to install 2nd stacking bracket on other side
-

