

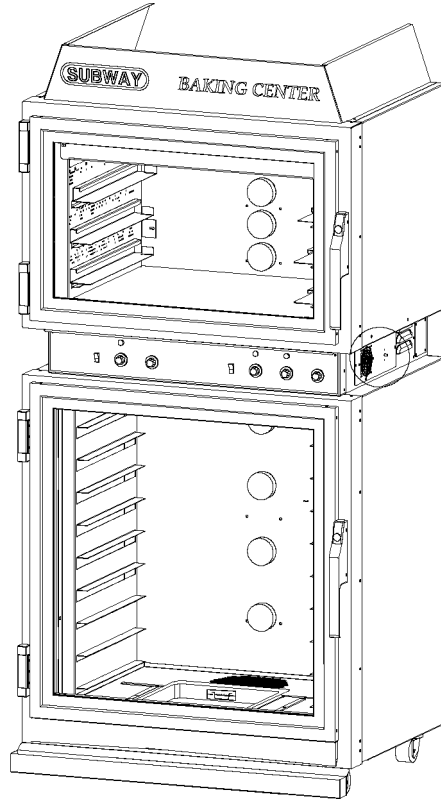

Illustrated Parts List

MODEL: EPO-3/9



Proofer Oven

*This manual is Copyright © 2005 Duke Manufacturing Company. All rights reserved.
Reproduction without written permission is prohibited. Duke is a registered
trademark of the Duke Manufacturing Company.*

Duke Manufacturing Company

2305 N. Broadway
St. Louis, MO 63102
Phone: 314-231-1130
Toll Free: 1-800-735-3853
Fax: 314-231-5074
www.dukemfg.com



TABLE OF CONTENTS

CONTROL PANEL.....	4
Table: PL-1 Control Panel.....	4
Figure: PL-1 Control Panel.....	5
MAIN CABINET COMPONENTS	6
Table: PL-2 Main Cabinet Components.....	6
Figure: PL-2 Main Cabinet Components	7

CONTROL PANEL

ITEM	PART NUMBER	DESCRIPTION
1	512852	Thermostat, Oven
2	154075	Buzzer
3	512971	Timer, 60 minute, 60 Hz
4	512850	Thermostat, proofer
5	512948	Thermostat, humidity, 208 volt
5	512949	Thermostat, humidity, 240 volt
6	512068	Light, indicator
7	512844	Mylar, control panel
Not Shown	512812	Holder, fuse
Not Shown	512813	Fuse, 20 amp
10	512289	Switch, lighted power
11	153142	Knob

Table: PL-1 Control Panel

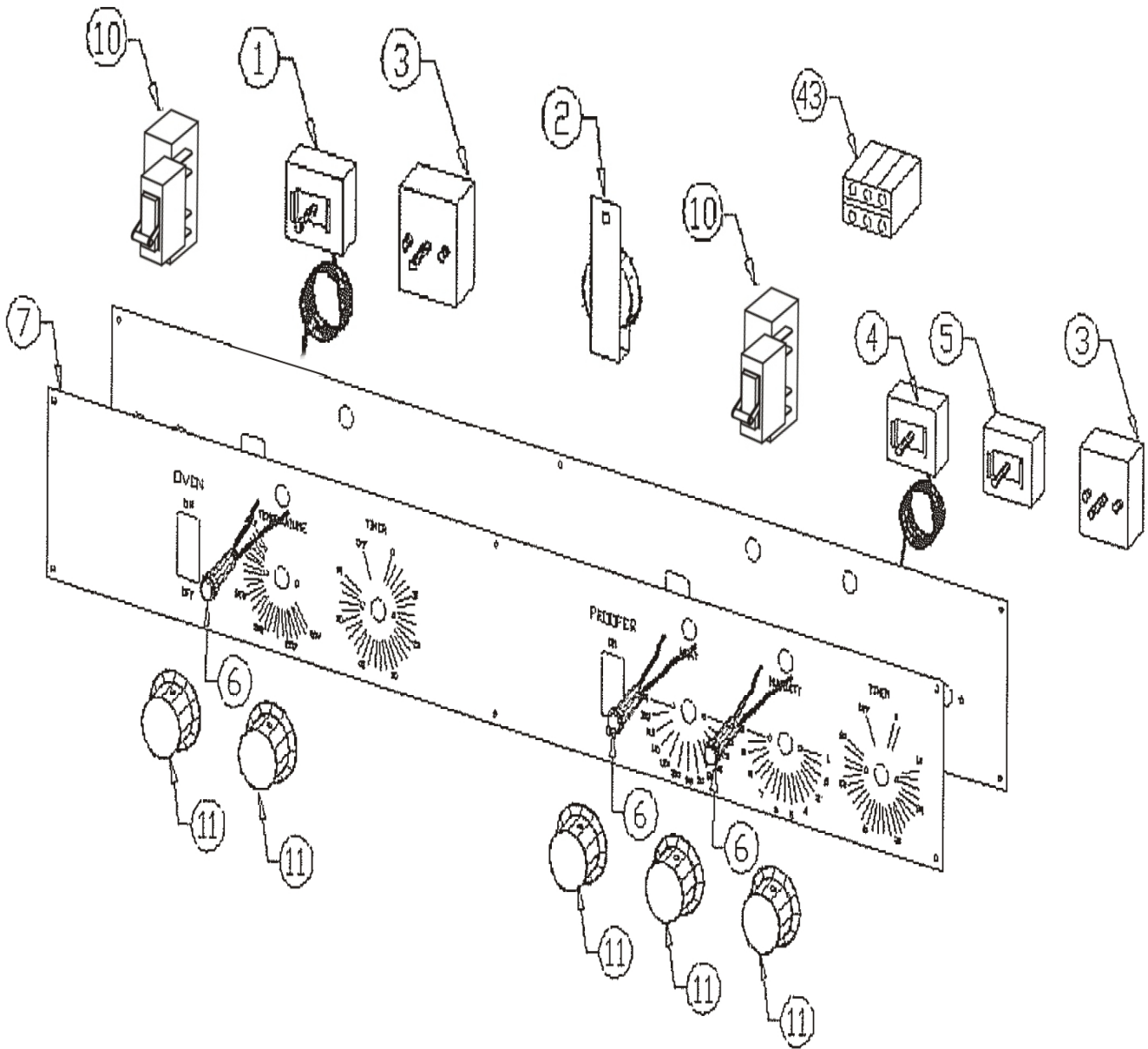
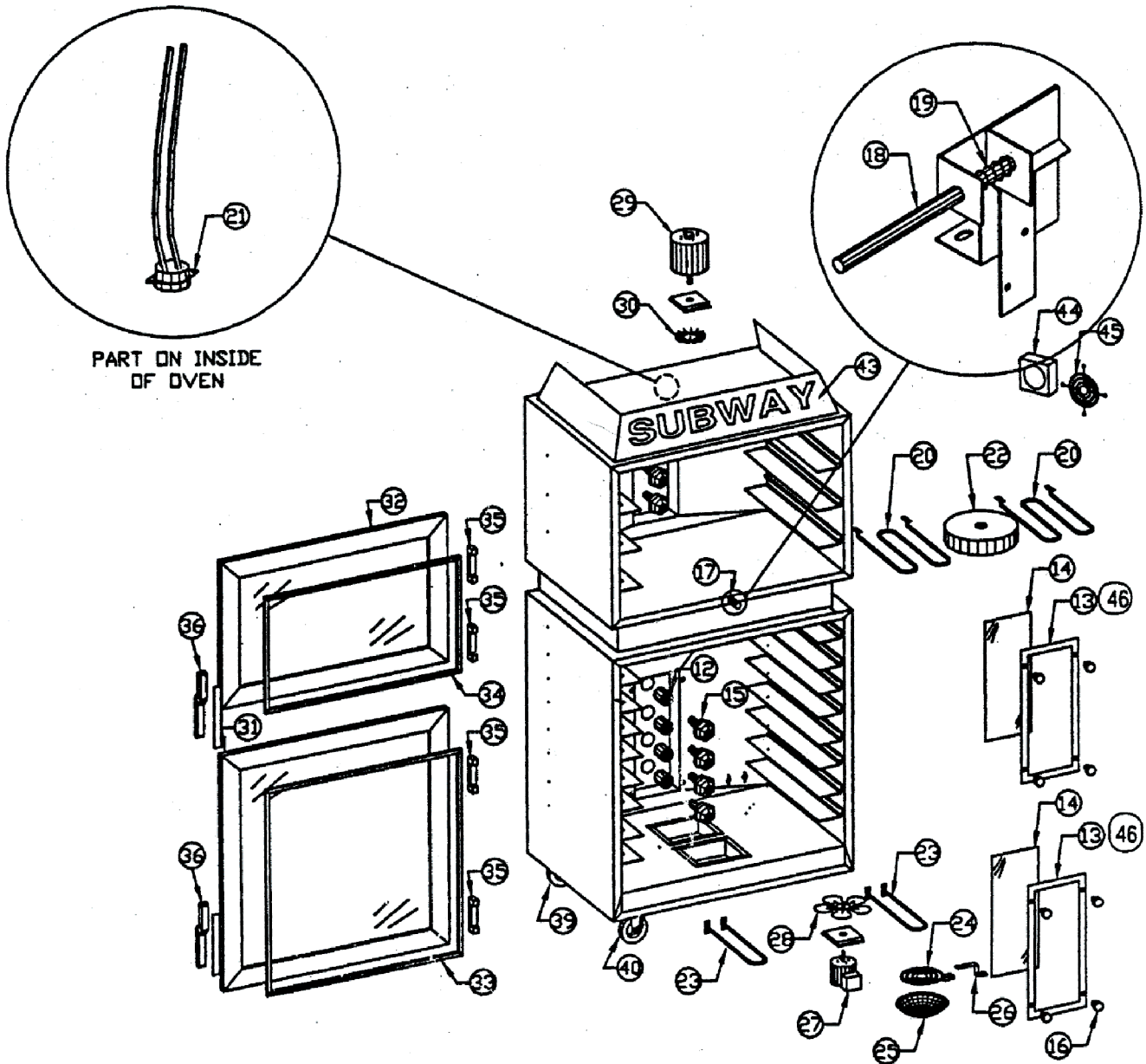

Figure: PL-1 Control Panel

MAIN CABINET COMPONENTS

ITEM	PART NUMBER	DESCRIPTION
12	147963	Socket, Light
13	502135	Frame only, glass light cover
14	512825	Glass only, light cover
15	156029	Light bulb, 40 watt
16	512806	Thumbscrew
17	512814	Safety switch, door
18	512821	Plunger rod, door switch
19	512843	Compression spring, door switch assembly
20	154373	Element 2.5Kw, 208 volt oven
20	502831	Element 2.5Kw, 240 volt oven
21	512855	Thermostat, high limit
22	512832	Blower wheel, oven
23	512895	Element 250 watt, 208 volt proofer
23	502833	Element 250 watt, 240 volt proofer
24	502727	Element 450 watt, 208 volt, humidity proofer
24	502832	Element 450 watt, 240 volt, humidity proofer
25	512816	Reflector dish, humidity element
26	512866	Mounting bracket, humidity element
27	512872	Motor proofer - 208/240 volt
28	512846	Fan blade, proofer motor
29	154470	Motor oven - 208/240 volt
30	154039	Blower Wheel - oven
31	512909	Proofer door assembly
32	502798	Oven door assembly
33	512914	Gasket, proofer door
34	512913	Gasket, oven door
35	512817	Hinge, door
36	512905	Handle & latch assembly
37	154547	Wire rack
38	512833	Contact, 3 pole, 30 amp
39	512835	Caster, locking w/brake
40	512836	Caster, swivel
41	512840	Terminal block, main
42	512854	Thermometer, oven
43	502912	Mylar, Bread Baking Center
44	159092	Cooling fan
45	512956	Fan guard
46	154034	Gasket
Not Shown	502934	Pan, humidity
Not Shown	512917	Screw, door hinge
Not Shown	512938	Screw, door handle

Table: PL-2 Main Cabinet Components





Duke Manufacturing Company

2305 N. Broadway
St. Louis, MO 63102
Phone: 314-231-1130
Toll Free: 1-800-735-3853
Fax: 314-231-5074
www.dukemfg.com