

Installation & Operation Manual

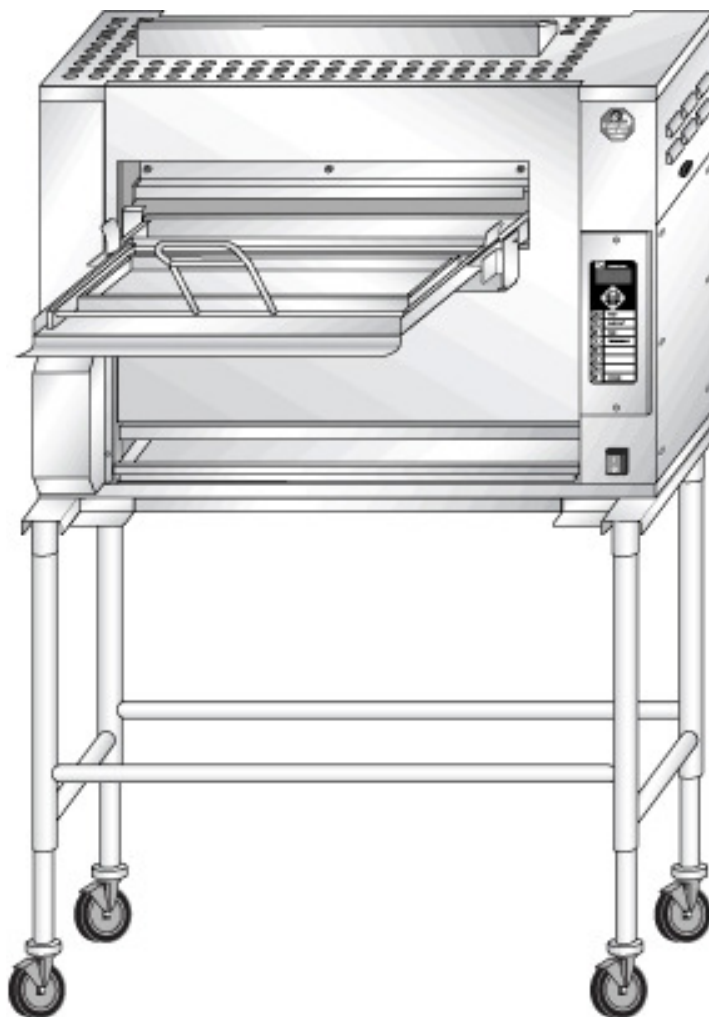

FLEXIBLE BATCH BROILER - CE



Duke Manufacturing Co.
2305 N. Broadway • St. Louis, Missouri
800-735-3853 • 314-231-1130 • Fax 314-231-5074
www.dukemfg.com

175820D
AS OF: 2/15/08



INDEX

	PAGE
I. General Information	3
A. Batch Broiler Specifications.....	3
A-1.0 Model Number Key	4
A-2.0 Broiler Dimensions.....	4
II. Installation Instructions.....	5
A. <i>Qualified Personnel</i>	5
B. <i>Delivery and Inspection</i>	5
C. <i>Broiler Assembly</i>	6
D. <i>Adjustments at Installation</i>	7
E. <i>Location of the Broiler</i>	8
F. <i>Gas Piping</i>	8
G. <i>Electrical Connections</i>	8
H. <i>Ventilation</i>	8
III. Operation Instructions.....	9
A. <i>Broiler Controls</i>	9
B. <i>Cooking Product</i>	10
B-1.0 Lighting the Broiler.....	10
B-2.0 Cook Product	10-11
B-3.0 Cook Cycle Complete	11
B-4.0 Fine Cooking Adjustment.....	11
B-5.0 Cancel a Cook Cycle	11
B-6.0 Checking the Broiler Temperature.....	11
B-7.0 Checking the Set Point Temperature.....	11
B-8.0 Shutdown the Broiler.....	11
C. <i>Cleaning</i>	12
C-1.0 Four (4) Hour Cleaning	14
C-2.0 Daily Cleaning.....	15-16
C-3.0 Weekly Cleaning.....	17-21
C-4.0 Monthly Cleaning	22-23
D. <i>Troubleshooting</i>	24-26
IV. Service and Repair	27
V. Replacement Parts List	28-29
VI. Wiring diagram.....	30
VII. Customer Assistance	31



POST IN A PROMINENT LOCATION

Instructions to be followed in the event the user smells gas. This information shall be obtained by consulting the local gas supplier.

FOR YOUR SAFETY:

Do not store or use gasoline or other flammable vapors or liquids in the vicinity of this or any other appliance.

WARNING:

Improper installation, adjustment, alteration, service or maintenance can cause property damage, injury or death. Read the installation, operating and maintenance instructions thoroughly before installing or servicing this

THIS MANUAL MUST BE RETAINED FOR FUTURE REFERENCE.

I. General Information

A. Batch Broiler Specifications

	I2H/I2E(G20)	I2L(G25)	I3B/P(G30)	I3P(G31)
ALTITUDE (MAXIMUM)	607 m	607 m	607 m	607 m
GROSS HEAT INPUT	29.4 KW	29.4 KW	25.2 KW	25.2 KW
GAS PIPE CONNECTION	12.7mm BSPT	12.7mm BSPT	12.7mm BSPT	12.7mm BSPT
	I2H/I2E(G20)	I2L(G25)	I3B/P(G30)	I3P(G31)
Supply Pressure	20 mbar	25 mbar	28-30 mbar	37/50 mbar
IR Burner Pressure	9.34 mbar	12.95 mbar	19.93 mbar	19.93 mbar
Lower Burner Pressure	9.34 mbar	12.95 mbar	19.93 mbar	19.93 mbar
	I2H/I2E(G20)	I2L(G25)	I3B/P(G30)	I3P(G31)
ORIFICE – Front IR Burner	2.35	2.35	1.40	1.55
ORIFICE – Rear IR Burner	2.50	2.50	1.51	1.61
ORIFICE – Lower Burner	3.05	3.05	1.70	1.85
SHIPPING WEIGHT	204 Kg (450 lbs)			
SHIPPING DIMENSIONS	121.9 cm x 99.1 cm x 172.7 cm (48" x 39" x 68")			
ELECTRICAL RATING	230V~ 50Hz 1.1A 250W			



FLEXIBLE BATCH BROILER

RESTAURANT
EQUIPMENT MANUAL

A-1. Model Number Key

FBB- X Y- 230

X identifies Gas Configuration

Y = O without Catalyst

Y = C with Catalyst

	Description	Model	Description	Model
<u>X</u> = 1	I3P(G31) gas w/o Catalyst	FBB-10-230	I3P(G31) gas with Catalyst	FBB-1C-230
<u>X</u> = 2	I2H/I2E(G20) gas w/o Catalyst	FBB-20-230	I2H/I2E(G20) gas with Catalyst	FBB-2C-230
<u>X</u> = 3	I3B/P(G30) gas w/o Catalyst	FBB-30-230	I3B/P(G30) gas with Catalyst	FBB-3C-230
<u>X</u> = 5	I2L(G25) gas w/o Catalyst	FBB-50-230	I2L(G25) gas with Catalyst	FBB-5C-230

A-2. Broiler Dimensions

Note:

Dimension shown in centimeters, bracketed [] are in inches

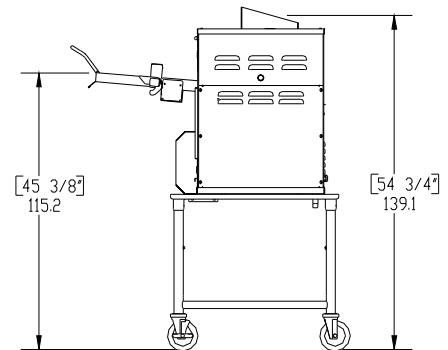
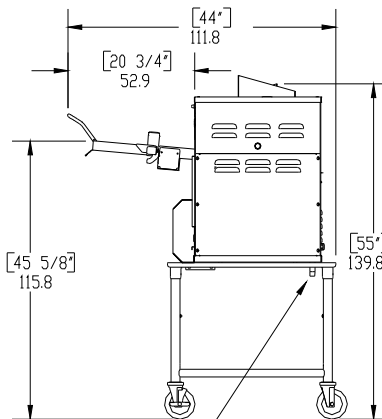
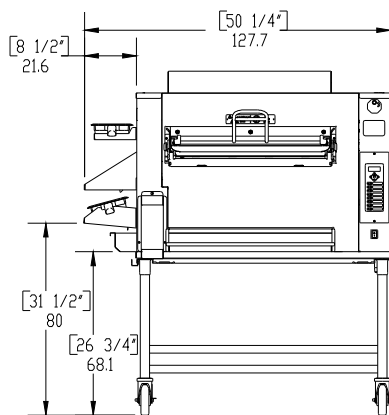
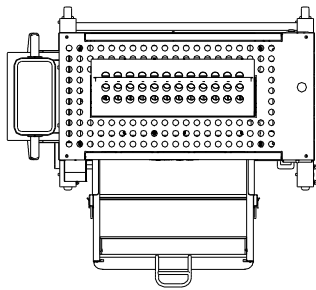

GAS CONNECTION
3/4" BSPT FEMALE

HIGH POSITION

LOW POSITION



II. Installation Instructions

A. Qualified Personnel

These installation instructions are for the use of **qualified installation and service personnel only**. Installation or service by other than qualified personnel may result in damage to the broiler and/or injury to the operator.

Qualified installation personnel are those individuals, firms, companies or corporations which either in person or through an agent is engaged in and responsible for:

- Compliance with the installation in force in the country in which the appliance is to be installed
- This appliance shall be installed with sufficient ventilation to prevent the occurrence of unacceptable concentrations of substances harmful to health in the room in which the appliance is installed
- Caution - the appliance is mounted on 4 wheels. Care must be taken not to hit kitchen walls or similar hard objects while moving or installing the appliance.
- Parts protected by the manufacturer, agent, or assignee shall not be adjusted by the installer

B. Delivery and Inspection

Duke Manufacturing Co. does everything within its power to insure you received your broiler in good condition. They are strapped down on heavy wooden skids and packed to prevent shipping damage. They have all been carefully inspected before they were packaged and consigned to the carrier.

Upon delivery of your Duke broiler:

- Look over the shipping container, carefully noting any exterior damage on the delivery receipt, which must also be signed by the driver/ delivery person.
- Unpack and check for any damage, which was not evident on the outside of the shipping container.

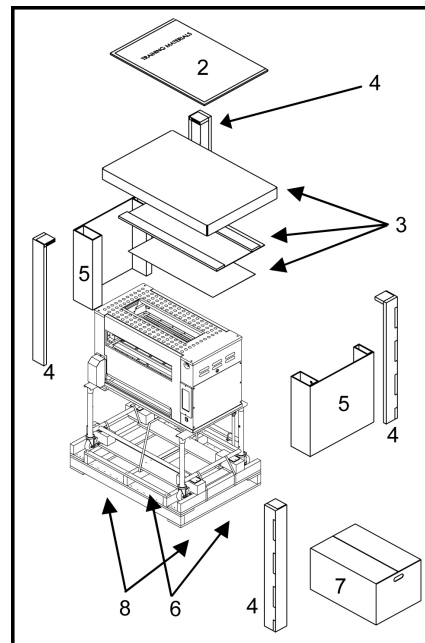

Caution: *The Broiler is very heavy!
Use adequate help for lifting.*

1. Using a utility knife, cut away plastic wrap (Not shown).
 2. Remove the top cardboard and inner cap
 3. Remove cardboard from the corners (4 places).
 4. Remove cardboard on the ends (2 places)
 5. Remove banding straps (Cut with utility knife or scissors: 5 places)
 6. Remove box of attachable parts & accessories from the front
 7. Safely lift one end of broiler and tap block towards center and then sideways to remove. Repeat for remaining blocks. This allows casters to touch the pallet
 8. While carefully supporting broiler, slowly roll it off the pallet taking care not to damage the casters
 9. Remove blue tape from broiler panels.
- Check for concealed damage. The carrier must be notified within fifteen (15) days of the delivery of the broiler and the carton, skid and all packaging materials must be retained for inspection.
 - Duke Manufacturing Co. cannot assume liability for loss or damage suffered in transit. The carrier assumes full responsibility for delivery in good order when the shipment was accepted. However, we are prepared to assist you with filing your claim.



FLEXIBLE BATCH BROILER

RESTAURANT
EQUIPMENT MANUAL

Page 6 of 31

C. Broiler Assembly

Before assembling and installing the broiler, please check to make sure that all necessary parts are present.

Item #	Part Name	Part #
1	PRODUCT PAN SHELF	175353
2	DISCHARGE CHUTE	175340
3	DISCHARGE HOOD	175362
4	DISCHARGE PAN HOLDER	175358
5	DISCHARGE GREASE PAN	175357
6	"V" GREASE PAN	175325
7	MAIN GREASE PAN	175329
8	LOADER	175444
9	LOADER TRAY	175430
10	LOADER BRACKET	175438
11	DOOR	175429
12	LOADER RAMP	175741
13	IMPEDANCE PAN	175226
14	CATALYST (OPTIONAL)	175480
15	CATALYST GUARD (OPTIONAL)	175482
16	SANITATION PAIL	175842

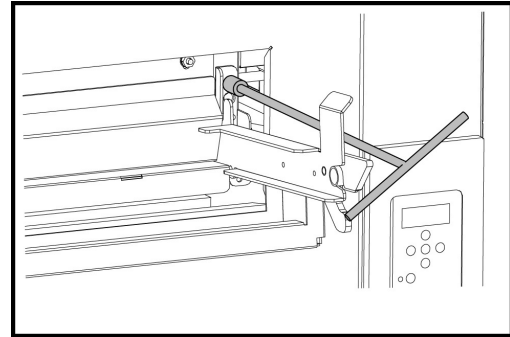

Loader Install Tool
(Included with Broiler Tools Kit)

OPTIMAL Service Parts & Accessories				
PARTS KIT - I2H/I2E(G20) (w/ Controller & Cook Chain)	175850		PARTS KIT - I2H/I2E(G20), I3B/P(G30) & I3P(G31) (Burner, Arrestor, Loader, & Burner Shield)	175526
PARTS KIT - I2L(G25) (w/ Controller & Cook Chain)	175851		PARTS KIT - I2L(G25) (Burner, Arrestor, Loader, & Burner Shield)	175853
PARTS KIT - I3B/P(G30) & I3P(G31) (w/ Controller & Cook Chain)	175852		KIT - CE GAS HOSE CONNECTOR	175831
PARTS KIT - I2H/I2E(G20), I3B/P(G30) & I3P(G31) (Burner & Flame Arrestor)	175520		KIT - CE GAS HOSE CONNECTOR - UK	175827
PARTS KIT - I2L(G25) (Burner & Flame Arrestor)	175854			

Setup: Install all items as shown below.

Note: Install loader bracket with (4) 1/4-20 nuts. Use supplied extension tool to remove and reinstall nuts. (Nuts are shipped installed on loader mounting studs.)

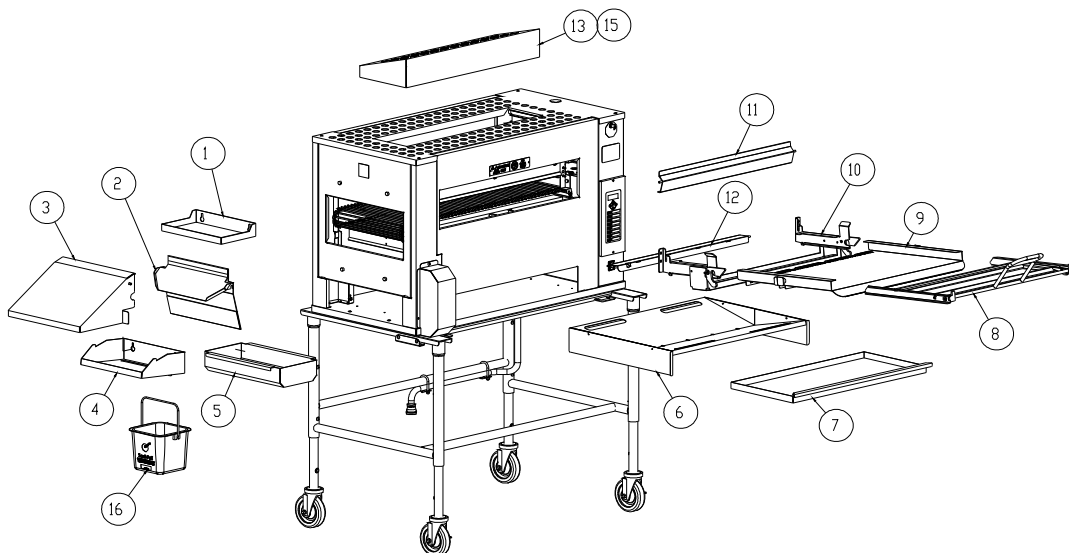



D. Adjustments at Installation

Each broiler section and all its component parts have been tested thoroughly and inspected before your broiler was shipped from the factory. However, it is sometimes necessary to further test or adjust the broiler once it has been installed. Such adjustments are the responsibility of the Dealer or Installer. These types of adjustments are not considered defects, rather a normal and routine part of the proper installation of the equipment.

These adjustments include but are not limited to:

- Adjustments to the gas pressure regulator
- Broiler height adjustment (if required)

No installation should be considered complete without proper inspection and, if necessary, any adjustments by qualified service or installation personnel.

It is also important not to obstruct the natural flow of combustion and ventilation air if the broiler is to operate properly. This broiler should not be installed on a curb base or sealed to the wall. Either condition can restrict the flow of air to the combustion compartment or prevent proper ventilation of the unit. Before making any connections to the broiler, check the ratings plate to be sure the broiler specifications concur with the type of gas and voltage to be supplied to the broiler.

The rating plate is located on the back of the control compartment cover panel on the right end of the unit.

The plate bearing the broiler's model number and serial number is attached to the back side of the unit.

Raise or Lower Broiler

The broiler height can be adjusted via two screws on each leg.

**Caution: The Broiler is very heavy!
Use adequate help for lifting.**

1. Lift one end of the broiler onto a wide, sturdy stand (not supplied).
2. Remove (2) screws per leg and raise/lower to threaded holes. Reinstall screws.
3. Remove stand and safely raise/lower broiler.
4. Place plastic hole plugs (supplied attach to stand) in any unused holes.

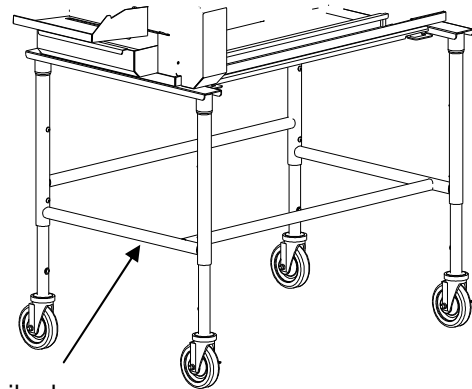

Support broiler here

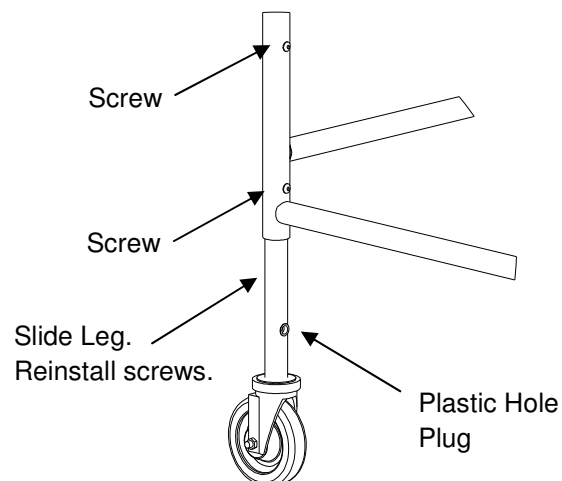



E. Location of the Broiler

Proper placement of the broiler will give you the best results long-term user convenience. We urge you to give adequate thought in the placement of your broiler prior to its arrival.

- The broiler should be placed in an area that is free from drafts and accessible for proper operation and servicing.
- The area around the broiler must be kept clear of combustible materials as specific below:

Combustible Surface Spacing	
Discharge End (left side)	305 mm
Access Panel End (right side)	76 mm
Rear	102 mm
Floor/Table	0 mm

F. Gas Piping

The standard broiler consumes gas at a total of **100,000 BTU/hr, 29.4 KW**. The overall piping plan of the kitchen must support the supply rating to support appliance to achieve the performance rating.

Generally, piping should be sized to provide a gas supply sufficient to meet the maximum demand of all gas appliances on a line without undue loss of pressure to the equipment. The total BTU requirements of all equipment being served and the piping length from the meter are major considerations in the proper design of the gas supply system.

NOTE: A fixed restraint of the proper length must be incorporated to secure the broiler to a non-movable surface to eliminate strain on the gas connector.

G. Electrical Connections

Your broiler must be supplied from a 230 Volt 50 Hertz, grounded circuit with a detachable line cord for each country's requirements. A wiring diagram is attached to the broiler control compartment and with this manual.

WARNING: This appliance employs an earthed, safety ground electrical supply system. DO NOT cut or modify the earthing provisions of this appliance.

H. Ventilation

This appliance shall be installed with sufficient ventilation to prevent the occurrence of unacceptable concentrations of substances harmful to health in the room in which the appliance is installed.

Venting to a Canopy Exhaust Hood

A mechanically driven exhaust hood must have a minimum capacity of 1700 m³/hr (1000 cfm) with a minimum 100cm by 130cm (39.4 in by 51.2 in) opening to adequately vent this appliance. The specified capacity and opening is required in a dedicated hood for this appliance or in addition to other appliance vented through a common canopy exhaust hood.

Maintenance of Ventilation System

The ventilation system must be maintained and annually inspected by Qualified Personnel concurrent as part of or in addition to governmental requirements.

This inspection/maintenance should consist of, but not be limited to:

- Inspection for blockages or build up which might interfere with the venting of the broiler.
- Repair of such blockages.
- Inspection of the venting canopy, its drive motors and bells, etc.

Warning: Do not place any objects such as sheet pans, food containers or aluminum foil on the top of the broiler. This will obstruct the venting of cooking vapors and airflow through the unit—resulting in poor cooking performance.



III. Operation Instructions

The information in this section is intended for the use of qualified operating personnel. Qualified Operating Personnel are those individuals who have carefully read the information contained in this manual, are familiar with the function of the broiler and/or have had experience with operating the equipment described. We recommend following these instructions to insure optimum performance, long life and trouble-free service from your broiler.

The controller is pre-programmed at the factory for known recipes at the time of manufacture.

The product keys must be programmed with an approved recipe and the broiler properly calibrated prior to use.

A. Broiler Controls

1. **Power Switch** – Turns the broiler ON or OFF. The broiler is self-lighting.
2. **Product Selection Keys** – Selects the product recipe to run. Also functions as number keys 1-8 in programming mode.
3. **Arrow Keys**
Up-Arrow: Displays the current broiler temperature when pressed in run mode. Scrolls backward through parameters when pressed in program mode.
Down-Arrow: Displays the broiler set-point temperature when pressed in run mode. Scrolls backward through parameters when pressed in program mode.
Left-Right Arrows: Moves between characters or parameters in program mode. Also used as numerals 0 and 9 keys.
4. **Display**
5. **Enter Key** – Press and hold for 5 seconds to enter program mode. Also used to move through and enter parameters in programming mode.
6. **Cook Light** – This light is lit during preheat and the entire cook. The operator should not load the broiler while the light is lit.

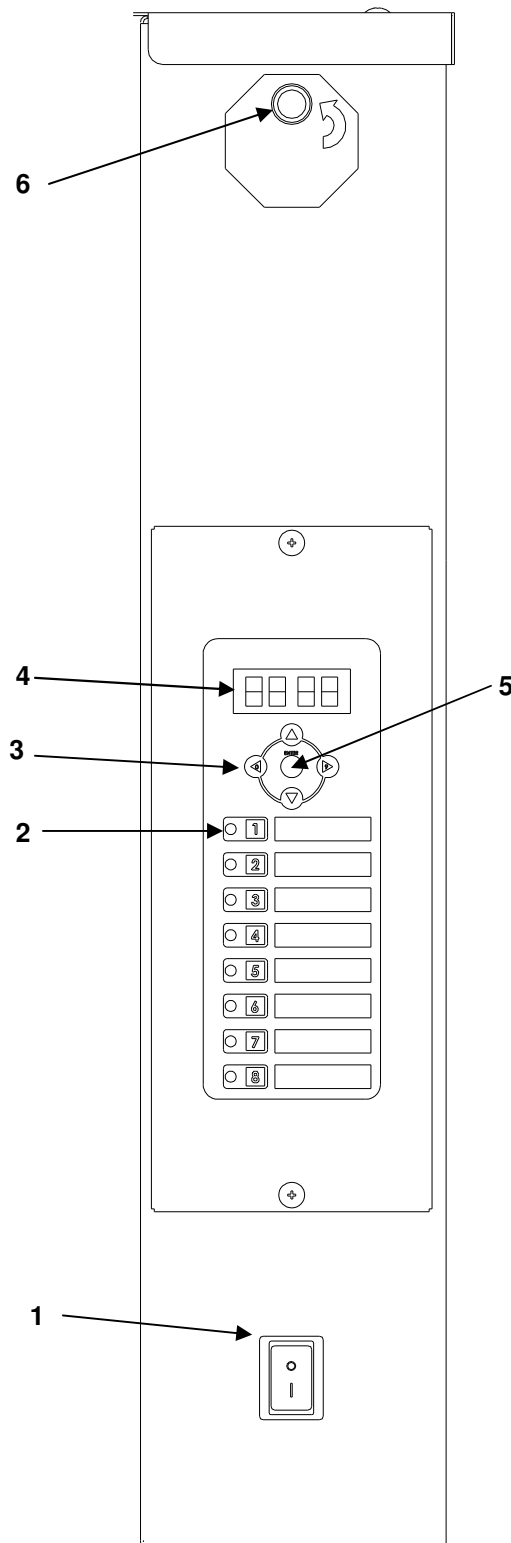



B. Cooking Product

B-1.0 Lighting the Broiler

- **Start Ventilation System.**
- Turn ON/OFF switch to the ON (1) position.
- The control will display **PrE** during the pre-heat cycle.
- The LED's next to all product keys with non-zero cook times will be red.
- The control will display **rdY** at the completion of the pre-heat cycle and the LED's next to all product keys with non-zero cook times will be green.
- (To shutdown the broiler, see section B-8.0)

B-2.0 Cook Product

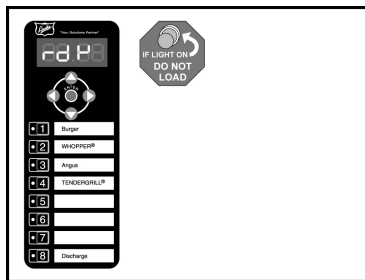

Broiler displays **rdY** and Cook light is **not** on.

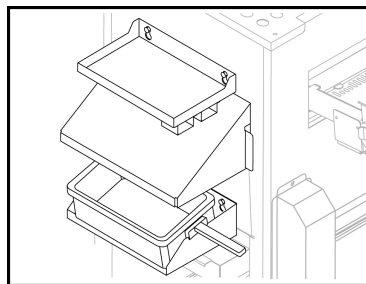

Place holding pan at discharge.

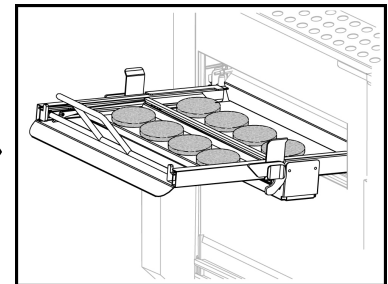

Place product in front and back rows.

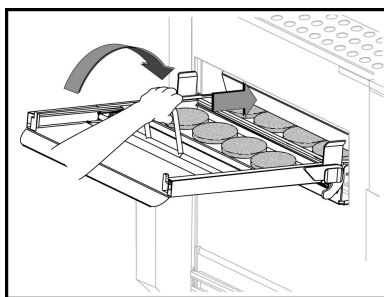

Load product. Push forward as shown.

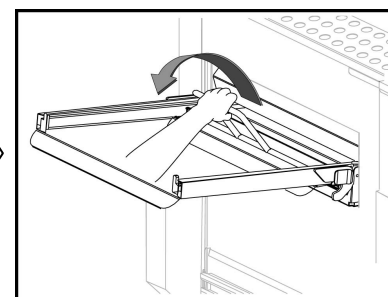

Rotate handle down to lift inside bar over product.

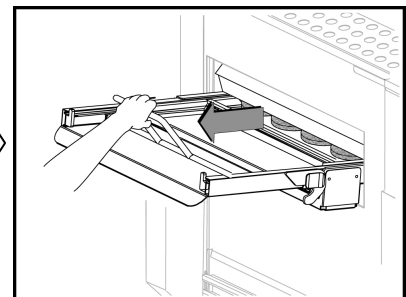

Pull out loader with handle rotated.

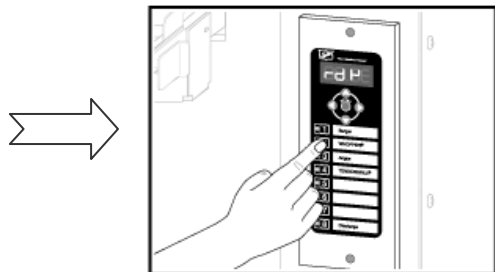

Press appropriate product key.

You will have 15 seconds to press another product key if a wrong selection is made.

The display will alternately display the time remaining and the four-character product identifier.

The LED next to the selected product key will flash red.

The cook light will be lit.



B-3.0 Cook Cycle Complete

The chain will rotate and discharge the product.

Do not load product into broiler until the cook light has gone off and **rdY is displayed on the control!**

To prevent thawing of product, it is recommended not to place product onto the loader no more than 5 minutes prior to loading.

B-4.0 Fine Cooking Adjustment

Use this function to add or subtract up to 30 seconds from a product cook cycle recipe. This should be used in the event product cooking needs to be optimized outside of the programming environment. This function works as follows:

Press and hold the ▲ and ▼ keys for 3 seconds.

The control will display **Adj**.

All product LED's for products with a programmed time will light red.

Select a product key to adjust.

The selected product LED will remain red and all other product LED's will go blank.

The control will flash **Adj** followed by the product identifier.

The ▲ and ▼ keys are used to set the fine cooking adjustment.

The first press of the ▲ or ▼ key brings up the adjustment screen. The control will display the total product cook time including the previous fine cooking adjustment.

Subsequent presses of a ▲ or ▼ key adds or subtracts 1 second from the cook time.

The cook time can be increased or decreased by up to 30 seconds with this function.

To exit this function and save the setting, press the ENTER key.

B-5.0 Cancel a Cook Cycle

Pressing and holding a product key for 3 seconds will cancel a cook cycle and discharge the product.

B-6.0 Checking the Broiler Temperature

Pressing the ▲ key at any time (other than in programming mode) will display the actual cavity temperature.

B-7.0 Checking the Set Point Temperature

Pressing the ▼ key at any time (other than in programming mode) will display the set-point cavity temperature.

B-8.0 Shutdown the Broiler

Turn ON/OFF switch to the OFF (O) position.



C. Cleaning

The exterior stainless steel on your broiler can be kept clean with a good non-abrasive stainless steel cleaner, many of which are on the market. Moisten a cloth and wipe down the broiler while it is COLD. Wiping down a broiler while it is hot will cause streaking and otherwise unsatisfactory results. Once the broiler is clean it can be wiped down with light oil.

To help make your use of this broiler trouble-free and to maintain the warranty, the following recommendations must be followed:

- A. Do not expose the broiler to prolonged contact with detergents, cleansers, bleaches, etc. Shield the IR burners and flame sensing rods from all cleaning fluids. Do not spray IR burners with any foreign materials. Chemical cleaners, degreasers, bleaches and soap solutions must never be allowed to come into contact with the IR burner metal housings or ceramic burner tiles as they may damage these surfaces and/or cause broiler malfunction and will void the warranty. To prevent damage to the ceramic burner tiles, never allow physical contact with cleaning tools or other objects that may scratch or mar the tile surfaces or cause blockage of the gas ports in the tile faces. Do not spray flame sensing rods with any foreign materials. Chemical cleaners, degreasers and soap solutions must never be allowed to come into contact with the flame sensing rods as they may damage these surfaces or cause broiler malfunction and will void the warranty. If required, clean the flame sensing rods only after allowing to cool off to room temperature, and using a light wiping action with a pre-saturated alcohol pad to remove any carbon buildup.
- B. Never leave the chemical compounds, particularly those containing chlorine, on broiler parts over night. Chlorine will cause pitting and corrosion.
- C. Never use chemicals in a stronger concentration than recommended by the manufacturer.
- D. Use clean water and a soft cloth to wipe cleaning residue from surfaces.
- E. Never use ordinary steel wool or scouring pads on the surfaces: use non-abrasive broiler degreasers & soft cloths

Carefully following these recommendations will help this broiler to give satisfactory services to extend its life.



FLEXIBLE BATCH BROILER

RESTAURANT
EQUIPMENT MANUAL

C. Cleaning (Continued)

Cleaning Schedule Recommendation	BROILER COOL	DISCONNECT POWER
4 Hour Cleaning by the User (<i>Sanitize in place</i>)		
SANITIZE LOADER & TRAY (CAUTION: HOT SURFACES, WEAR INSULATED GLOVES WHILE CLEANING)		
SANITIZE DISCHARGE CHUTE		
Daily Cleaning by the User (<i>Remove and Wash/Rinse/Sanitize</i>)		
DISCHARGE PAN (CAUTION: HOT SURFACES, WEAR INSULATED GLOVES WHILE CLEANING)		
DISCHARGE HOOD	X	
DISCHARGE GREASE PANS	X	
MAIN GREASE PANS	X	
DISCHARGE END PANEL	X	
DISCHARGE SCRAPER	X	
LOADER & TRAY (CAUTION: HOT SURFACES, WEAR INSULATED GLOVES WHILE CLEANING)		
DISCHARGE CHUTE	X	
LOADER RAMP	X	
Weekly Cleaning by Qualified Service Personnel Only		
FLAME ARRESTOR	X	X
BROILER FLIPPER DOOR	X	X
LOWER TUBE BURNER	X	X
FLAME SENSOR (UPPER BURNERS)	X	X
FLAME SENSOR (LOWER BURNERS)	X	X
FLAME SENSOR TUBE (UPPER BURNERS)	X	X
Monthly Cleaning by the User		
CATALYST	X	X



C-1. Four (4) Hour Cleaning

All components that are in contact with food product must be cleaned and sanitized every 4 hours.

Loader and Carriage: Remove loader from carriage and sanitize food contact areas.

Caution: Hot surface near door!
Wear insulated gloves.

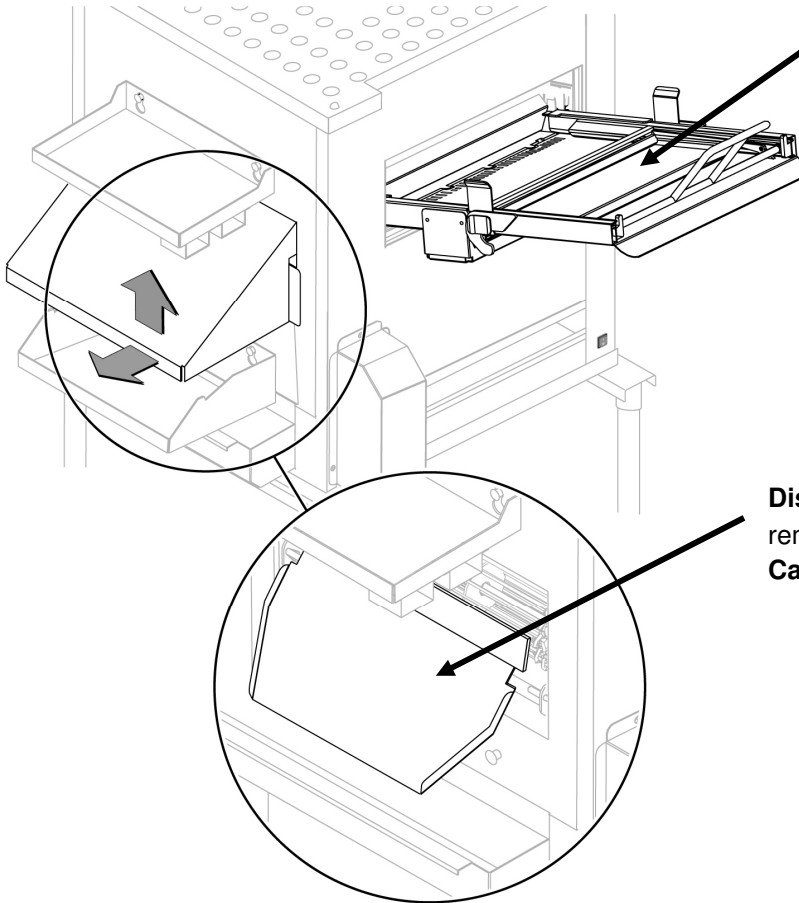

Discharge Chute: With discharge hood removed, sanitize outside chute surface.

Caution: Hot surface!
Wear insulated gloves.



C-2. Daily Cleaning

Daily cleaning should also include all items listed in the 4 hour cleaning schedule.

Discharge Hood and Chute: Remove hood and chute completely, clean and replace.

Discharge Pan: Slide pan up and out of keyhole slots. Clean and replace.

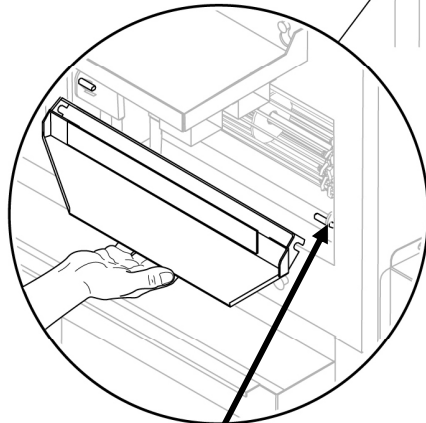

Engage hooks on pins for reinstallation of chute

Discharge Grease Pan: Tilt up to un-hook and pull forward for removal. Clean pan, area and replace.

Be sure to tilt up and push all the way back during re-installation!

Grease Pans: Remove top "V" pan and lower collection pan. Clean both pans, area and replace.

Caution: Very Hot! Wait for pan to cool before removal.

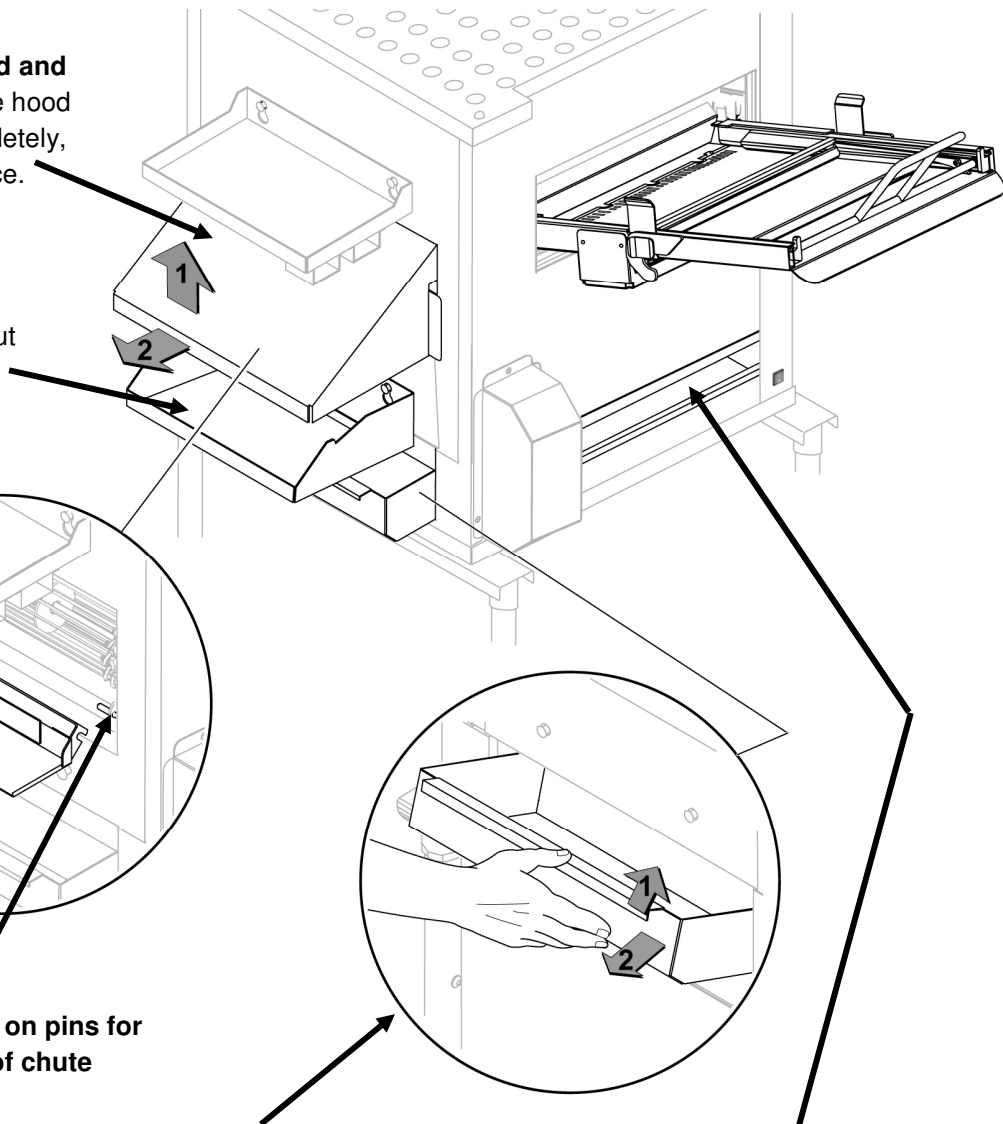



C-2. Daily Cleaning (cont'd)

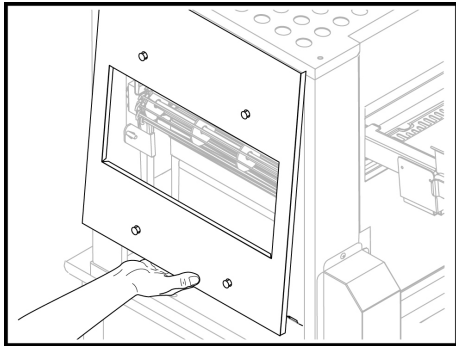

Discharge End Panel:
Remove discharge accessories
and lift panel up while swinging
out and down.

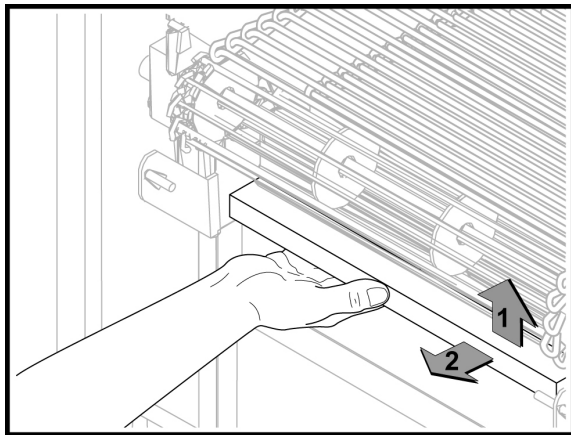

Discharge Scraper: Lift up and
pull forward.

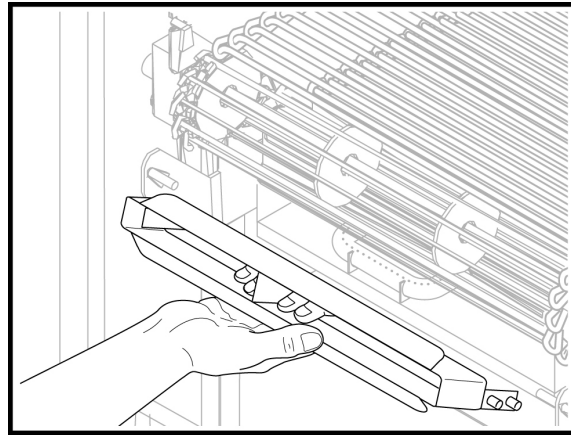

Discharge Scraper: Pull out removing
locating pins from slots. Clean scraper
and area. Replace.

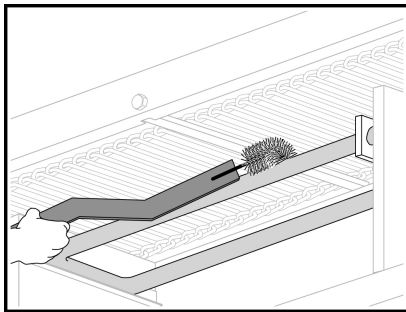

Clean the top of the burner
with the brush end of the
"Tube Burner Cleaning Tool".

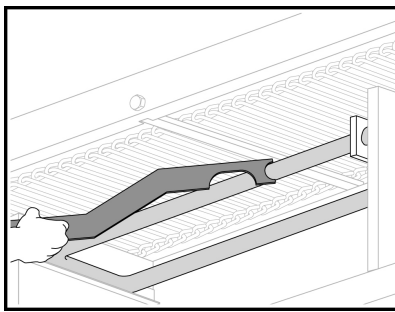

For heavy build-up, use the
scraper end of the "Tube
Burner Cleaning Tool".

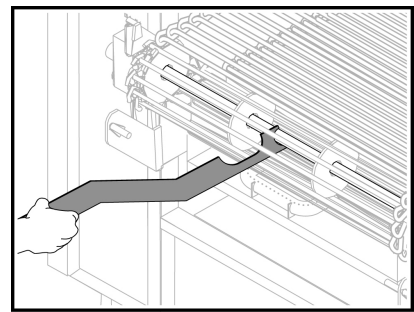

Use the end of the tool to
clean the discharge shaft of
the conveyor.



C-2. Daily Cleaning (cont'd)

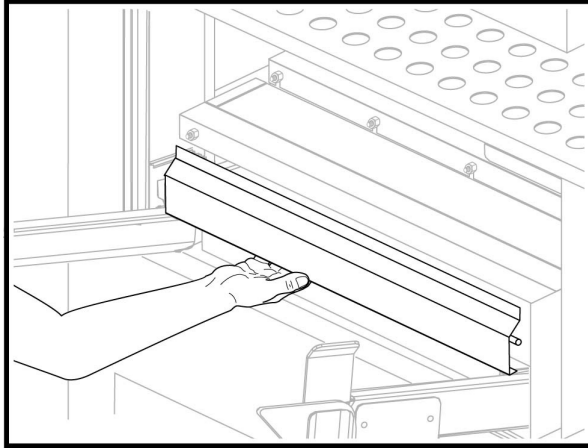

With the broiler cool, lift and remove the flipper door. Clean and set aside.

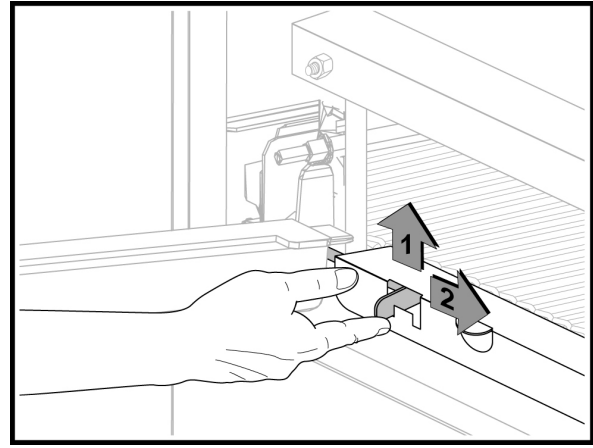

Lift and slide retaining bolt right

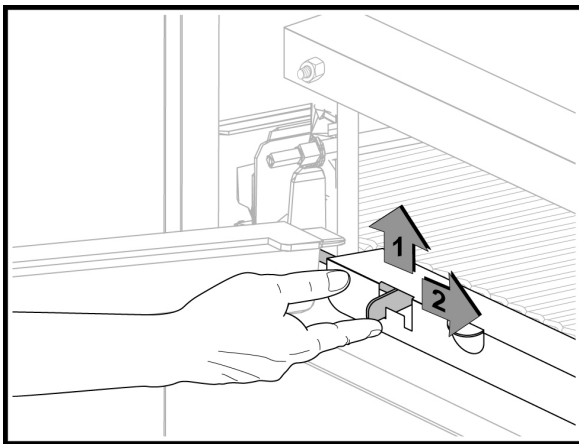

Lift slightly and remove loader ramp as shown.

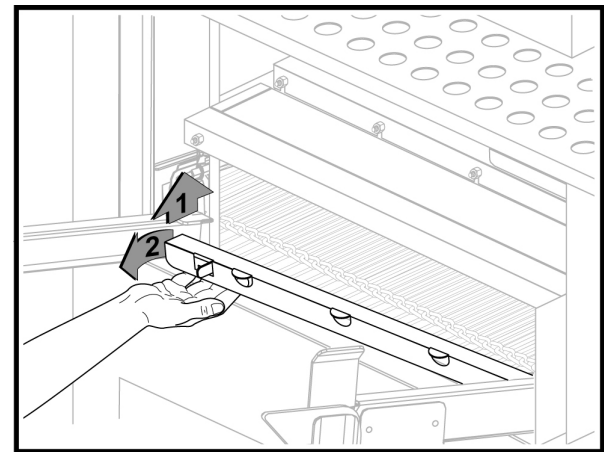

Disengage pin from pivot hole. Clean and set aside.



C-3. Weekly Cleaning

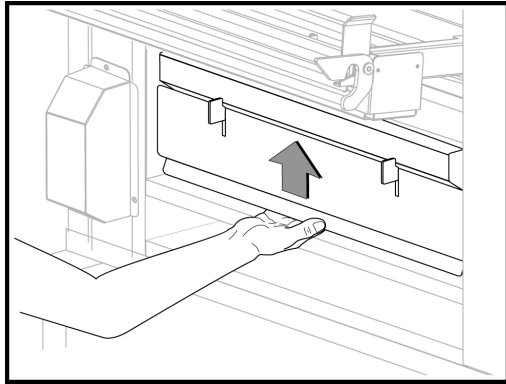

With outer front panel removed. Lift up the combustion chamber panel.

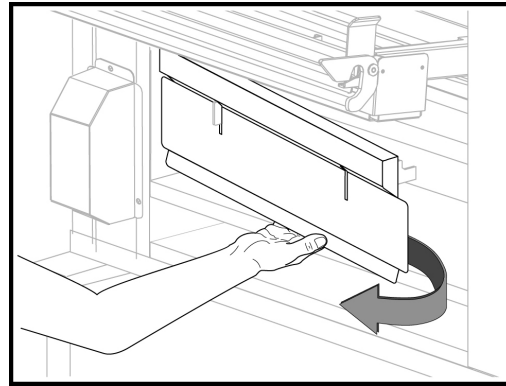

Swing the right side of the panel out as shown. Clean and set aside.

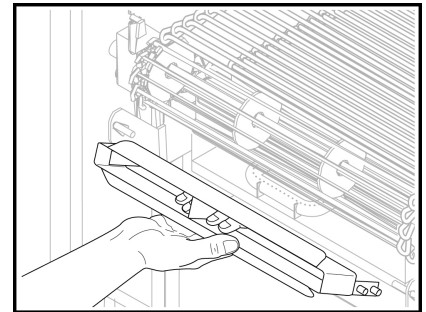
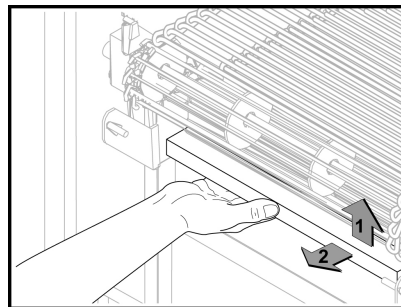
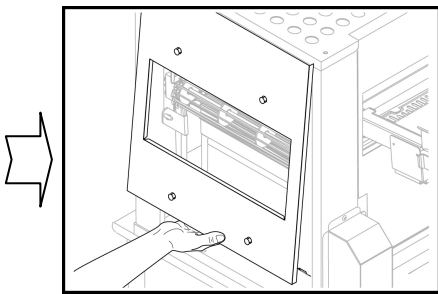

Remove discharge panel and scraper as was performed for daily cleaning.

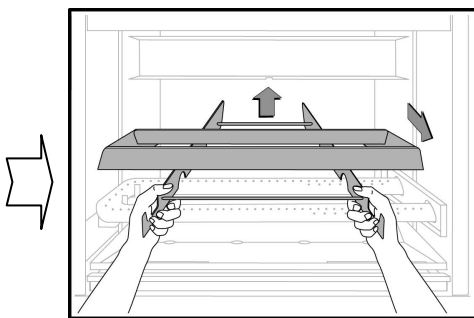

Remove burner shield.

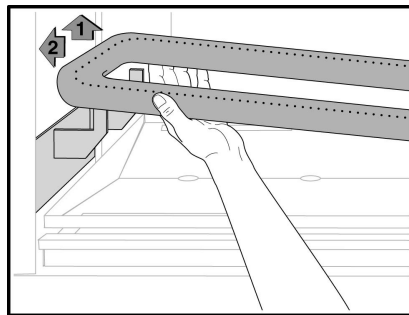

Lift rear of burner out of saddle and continue to hold it.

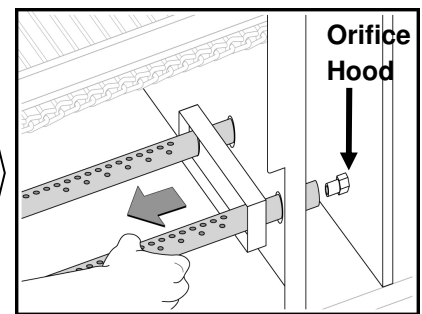

Pull burner off of orifice and through broiler wall. Remove from chamber. Clean, empty any remaining water from the burner and replace.

Thoroughly dry out all burner ports!



C-3. Weekly Cleaning (cont'd)

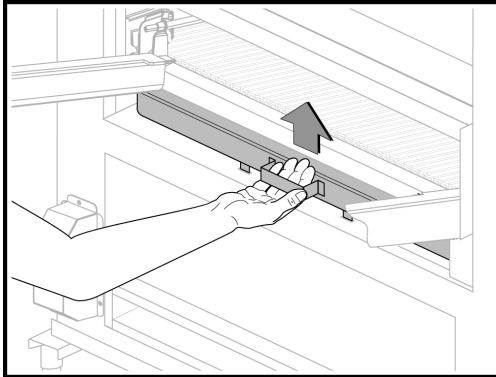

Lift flame arrester up to disengage tabs from slots. Tabs are located under the front of the arrester

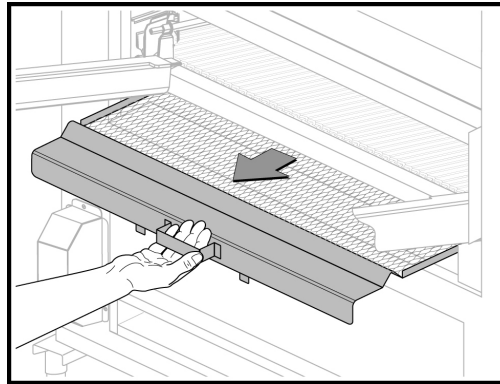

Pull flame arrester out. Clean and reinstall.

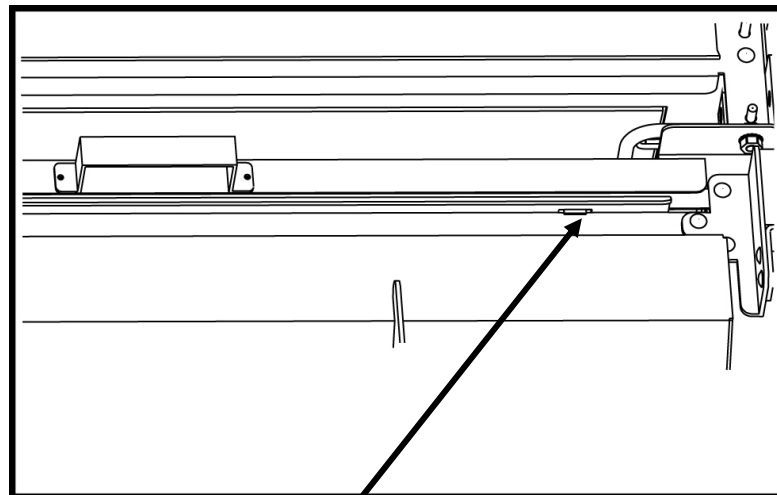

TAB ON THE BOTTOM OF THE FLAME ARRESTOR
DROPS INTO SLOT



C-3. Weekly Cleaning (cont'd)

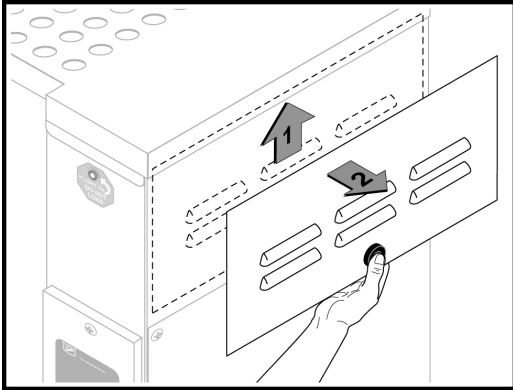

Remove top panel by lifting up and out.

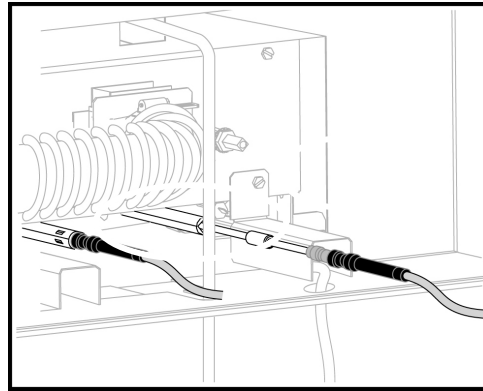

Locate the two flame sensors for the Infrared burners.

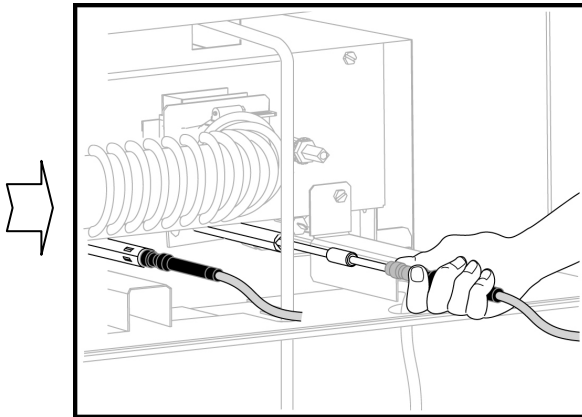

With the broiler cool, remove sensor by pulling on the black covering near the ceramic as shown.

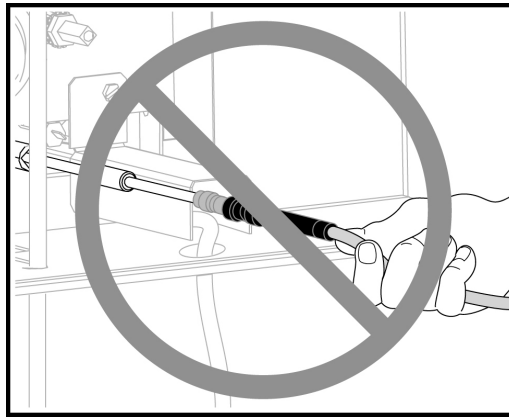

Do not pull on the wire to remove.

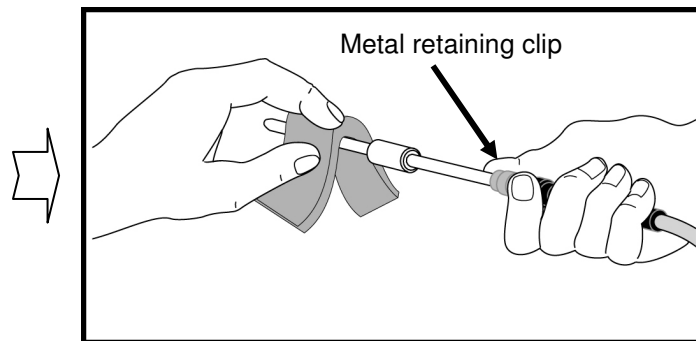

Clean rod & ceramic insulators with alcohol pad or soft cloth & isopropyl alcohol. Replace the sensor. Take care to insert the sensor all the way into the tube so the metal retaining clip is no longer exposed.



C-3. Weekly Cleaning (cont'd)

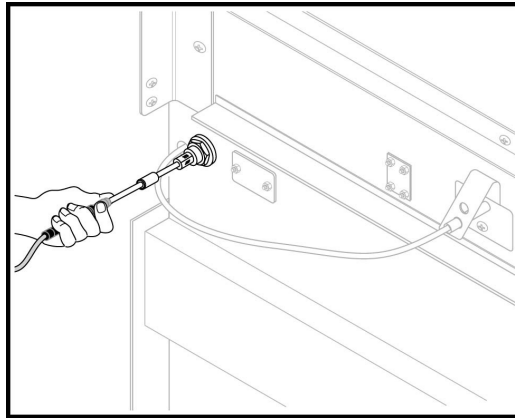

With the broiler cool, remove the rear panel of the broiler and remove the sensor for the lower burner. Follow the same procedures as those for the top sensors.

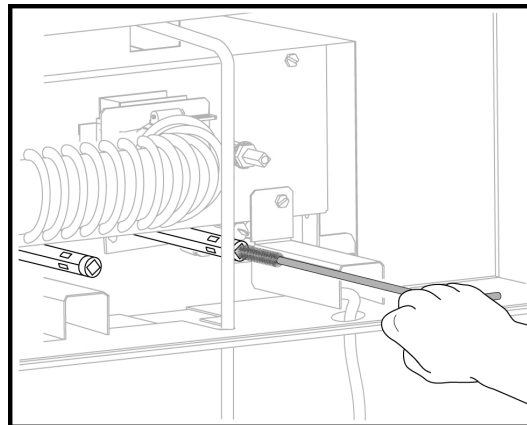

After the sensor is removed take the t-handled cleaning rod and carefully run the brush through the Flame Sensor Tube. Push and pull the brush through each tube a few times to make sure it is clean.



C-4. Monthly Cleaning

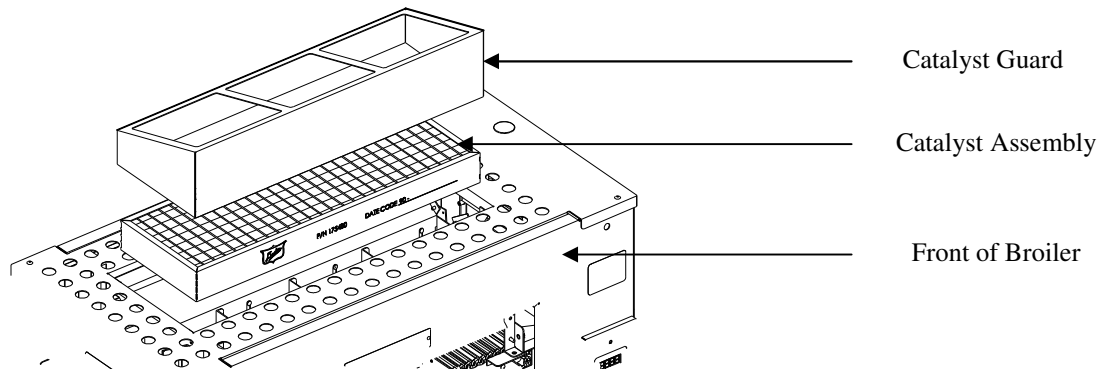

CLEANING CONSIDERATIONS

Warning: Do not use soap, detergents, degreasers, silicone, sodium salts, bleaches, anti-oxidants or any other commercial cleaning agents to clean the catalyst. Use of these chemicals will damage the catalyst and render it inoperable

NOTE: Do not clean catalyst in a dishwasher or ultrasonic cleaner. In no case should any abrasive material or abrasive scrubber be used for cleaning.

SAFETY CONSIDERATIONS

The catalytic converter (catalyst) is normally part of a combustion system, and the general safety practices observed with such systems should be practiced. The following considerations are specific to the catalyst portion.

- A: Remove power: Before removing the catalyst, disconnect power to the broiler and allow to cool to room temperature. Remove the catalyst guard and set aside for re-installation after the catalyst has been cleaned.
- B: Handling catalyst: Care should be taken so that the catalyst is not dropped or damaged in handling. If the unit is going to be handled soon after a cooking cycle, care should be taken to protect one's hands from any hot surfaces by wearing gloves designated for this purpose. There are no moving parts or electrical hookups associated with the catalyst, therefore there should be no danger of a shock hazard when washing the unit. Allow the catalyst to cool to room temperature before starting the cleaning process.
- C: Operation: Understand and follow the system instructions provided with the broiler included in the installation and operations manual. It is very important that you make sure that the ducts above the cooking appliance are clean of any grease, prior to the initial operation of the appliance with the catalytic converter in place. **IF NATURAL GAS IS PART OF THE EXHAUST STREAM, BE SURE THAT THE NATURAL GAS DOES NOT BUILD UP TO AN EXPLOSIVE MIXTURE IN THE EXHAUST SYSTEM.**



C-4. Monthly Cleaning (cont'd)

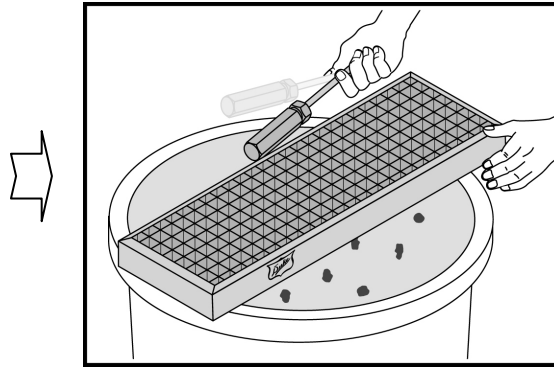

Gently tap frame of the catalyst while holding over a waste bin to dislodge any loose ash/carbon particles.

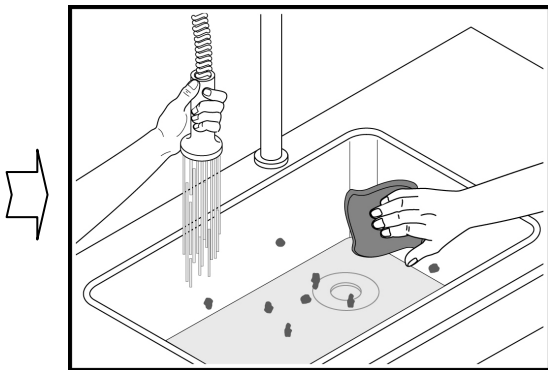

Begin with a clean sink and remove all foreign matter from any wash basin used, before starting the catalyst washing process.

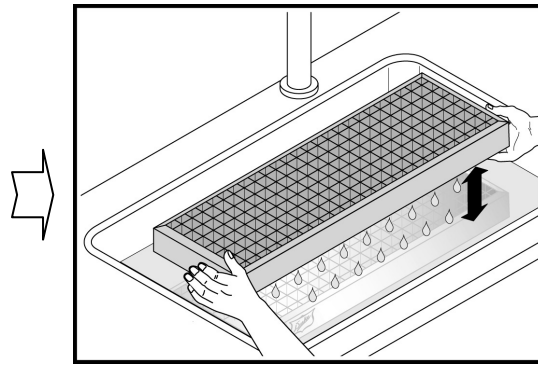

Partially fill wash basin, that is large enough to accommodate the catalyst, with enough clean hot water (100-130°F) to completely cover the catalyst when placed into the basin. Agitate the catalyst up and down in the water a few times and then let it soak for 20 minutes.

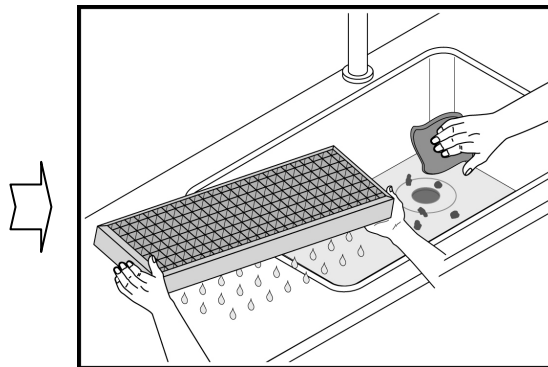

Remove the catalyst and shake out the excess water. Drain and clean the basin thoroughly and then repeat step 3

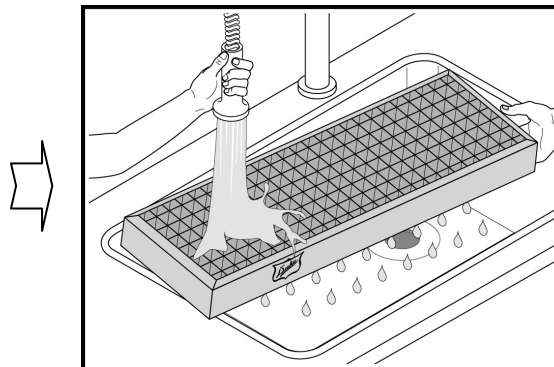

Remove the catalyst and rinse thoroughly with a large volume of hot water. The typical restaurant dish washing spray nozzle (low pressure, high volume) is perfect for this operation. Work the spray slowly over the entire surface both front and back to assure the removal of any particles caught in the catalyst face or behind the frame. Shake the remaining water from the catalyst and then let it air dry overnight. The catalyst can then be reinstalled in the broiler. Ensure that the catalyst guard is re-installed over the catalyst prior to turning on the broiler.



D. Troubleshooting

SYMPTOM	CAUSE	REMEDY
Control display does not light up	No power	Ensure broiler is plugged into a proper voltage/Hz receptacle (per name plate rating) and receptacle as power. Check dedicated circuit breaker.
Raw or undercooked product with no controller error messages displayed.	<p>Product not loaded properly.</p> <p>Product button was depressed prior to loading product.</p> <p>Wrong product button was depressed.</p> <p>Lower burner not lighting properly. (Observe bottom burner through slits in lower grease tray)</p> <p>Infrared burners not lighting properly. (Observe Infrared through discharge end of broiler. Note: Burners should remain lit in idle mode)</p>	<p>Review loading technique.</p> <p>Ensure product button is depressed immediately after product is loaded into broiler.</p> <p>Ensure proper product button is being depressed.</p> <p>If broiler is hot, attempt to clean burner in place with broiler cleaning tool.</p> <p>If broiler is cold or allowed to cool down, remove lower burner by removing access panels, clean, and reinstall. Remove lower flame sensor and clean with a soft cloth & isopropyl alcohol.</p> <p>Remove upper control compartment panel and clean 2 upper flame sensors with a soft cloth & isopropyl alcohol.</p> <p>Clean flame sensor tube with flame sensing tube cleaning brush.</p>
Conveyor belt will not move to discharge product.	Conveyor belt is being obstructed	<p>Observe for obstructions by manually rotating conveyor belt from discharge end of broiler using broiler cleaning tool.</p> <p>Ensure discharge scraper is properly in place.</p> <p>Ensure docking plate is properly in place.</p> <p>Ensure flame arrestor is properly in place.</p>
Loader is not able to be pushed completely into cooking chamber	Docking plate is not properly in place.	Ensure docking plate and locking tab are correctly in place.
Product is getting stuck or mangled upon loading	Docking plate is not properly in place	Ensure docking plate and locking tab are correctly in place.
	Flame arrestor is not properly in place	Ensure flame arrestor is correctly in place and tabs are slotted correctly.



FLEXIBLE BATCH BROILER

RESTAURANT
EQUIPMENT MANUAL

Page 25 of 31

SYMPTOM	CAUSE	REMEDY
Control display is reading "Hi"		Contact Duke Manufacturing Co. or a Duke Authorized Service agent.
Control display is reading "Lo"	<p>Lower burner not lighting properly. (Observe bottom burner through slits in lower grease tray)</p> <p>Infrared burners not lighting properly. (Observe Infrared through discharge end of broiler. Note: Burners should remain lit in idle mode)</p> <p>Grease pan is not installed</p> <p>Impedance pan or catalyst is not installed.</p>	<p>If broiler is hot, attempt to clean burner in place with broiler cleaning tool.</p> <p>If broiler is cold or allowed to cool down, remove lower burner by removing access panels, clean, and reinstall. Remove lower flame sensor and clean with a soft cloth & isopropyl alcohol.</p> <p>Remove upper control compartment panel and clean 2 upper flame sensors with a soft cloth & isopropyl alcohol.</p> <p>Clean flame sensor tube with flame sensing tube cleaning brush.</p> <p>Install grease pan</p> <p>Install impedance pan or catalyst</p>
Control display is reading "Prob"		Contact Duke Manufacturing Co. or a Duke Authorized Service agent.
Control Display is reading "tEst Prod"	<p>Lower burner not lighting properly. (Observe bottom burner through slits in lower grease tray)</p> <p>Infrared burners not lighting properly. (Observe Infrared through discharge end of broiler. Note: Burners should remain lit in idle mode)</p>	<p>If broiler is hot, attempt to clean burner in place with broiler cleaning tool.</p> <p>If broiler is cold or allowed to cool down, remove lower burner by removing access panels, clean, and reinstall. Remove lower flame sensor and clean with a soft cloth & isopropyl alcohol.</p> <p>Remove upper control compartment panel and clean 2 upper flame sensors with a soft cloth & isopropyl alcohol.</p> <p>Clean flame sensor tube with flame sensing tube cleaning brush.</p>
Control display is reading "gAS toP"	Broiler not receiving gas supply.	Ensure that gas valve(s) in line with the broiler are in the ON position.



FLEXIBLE BATCH BROILER

RESTAURANT
EQUIPMENT MANUAL

Page 26 of 31

SYMPTOM	CAUSE	REMEDY
	Infrared burners not lighting properly. (Observe Infrared through discharge end of broiler. Note: Burners should remain lit in idle mode)	Remove upper control compartment panel and clean 2 upper flame sensors with a soft cloth & isopropyl alcohol. Clean flame sensor tube with flame sensing tube cleaning brush.
Control display is reading "gAS bot"	Broiler not receiving gas supply. Lower burner not lighting properly. (Observe bottom burner through slits in lower grease tray)	Cycle broiler off and back on. If this error persists, proceed with the next steps. Ensure that gas valve(s) in line with the broiler are in the ON position. If broiler is hot, attempt to clean burner in place with broiler cleaning tool. If broiler is cold or allowed to cool down, remove lower burner by removing access panels, clean, and reinstall. Remove lower flame sensor and clean with a soft cloth & isopropyl alcohol.
Control display is reading "gAS SEnt"	Infrared burners not lighting properly. (Observe Infrared through discharge end of broiler. Note: Burners should remain lit in idle mode)	Remove upper control compartment panel and clean 2 upper flame sensors with a soft cloth & isopropyl alcohol. Clean flame sensor tube with flame sensing tube cleaning brush.
Control display is reading "gAS SEnb"	Lower burner not lighting properly. (Observe bottom burner through slits in lower grease tray)	If broiler is hot, attempt to clean burner in place with broiler cleaning tool. If broiler is cold or allowed to cool down, remove lower burner by removing access panels, clean, and reinstall. Remove lower flame sensor and clean with a soft cloth & isopropyl alcohol.



IV. Service and Repair

Periodic service and maintenance of the broiler is not required beyond the user's daily and weekly cleaning schedule defined in Sections C-1 to C-4. Qualified service personnel **must** perform service or repair should the broiler develop a fault other than cleaning maintenance.

Qualified service personnel are individuals, firms, companies, or corporations who are knowledgeable in and responsible for compliance with jurisdiction authorities concerning service of commercial food preparation equipment. Contact the Duke Manufacturing Company Service Department at the USA worldwide headquarters (telephone: 011-800-735-3853) for assistance with selecting qualified service personnel.

WARNINGS to qualified service personnel:

- Disconnect the power supply to the appliance before servicing.
- Units provided with casters have a restraint to limit the movement that must be reconnected after servicing and installed in the original position.
- Proper clearances must be maintained during servicing and when installed in the original position.



V. Replacement Parts List

Parts that will likely require replacement during the life of the broiler are identified with a “◀” in the Replacement Parts List. The “Ø” symbol in the list identifies parts that are protected and shall not be or cannot be adjusted by the user. Parts identified with a “-” should not require adjustment or replacement during the broiler life, but are listed to assist qualified service personnel if replacement is necessary.

P/N	DESCRIPTION	
175503	SWITCH,LIGHTED,DPST	-
175780	BURNER,INFRARED	◀, Ø
175505	BURNER,TUBE,J STYLE (I2H/I2E(G20), I3B/P(G30), & I3P(G31))	◀, Ø
175803	BURNER,TUBE,J STYLE (I2L(G25) ONLY)	◀, Ø
175875	MOTOR-CONVEYOR	-
175517	SPROCKET, B21X3/8 BORE (MOTOR)	Ø
175037	SHAFT,DISCHARGE SIDE	Ø
175038	SHAFT,RIGHT SIDE	Ø
175802	CAPACITOR,MOTOR-CONVEYOR	Ø
175876	MODULE IGNITION (7-5-3) CE (PROPANE, LOWER BURNER ONLY)	◀, Ø
175877	MODULE IGNITION (24-5-3) CE	◀, Ø
175765	TRANSFORMER,40VA, 230VAC-24VAC	Ø
175977	PROBE,TEMP., C-CHAMBER	Ø
175550	LIGHT, COOK	-
175870	RELAY - SOLID STATE	◀, Ø
175551	CHAIN, DRIVE	Ø
175918	CONTROLLER	Ø
175510	GASKET, CONTROL BEZEL	-
175511	GASKET, BLOWER INLET	-
175874	BLOWER, DAYTON 230V 50HZ	◀, Ø
175532	HOSE, BLOWER	◀, Ø
175542	ORIFICE HOLDER, IR	-
175920	VALVE, GAS, COMBO	◀, Ø
175823	ORIFICE, 3.05mm, LOWER BURNER (I2H/I2E(G20), I2L(G25))	Ø
175953	ORIFICE, 1.85mm, LOWER BURNER (I3P(G31))	Ø
175952	ORIFICE, 1.70mm, LOWER BURNER (I3B/P(G30))	Ø
175814	ORIFICE, IR FRONT, 2.35mm, G I2H/I2E(G20) & I2L(G25)	Ø
175815	ORIFICE, IR REAR, 2.50mm, G I2H/I2E(G20) & I2L(G25)	Ø
175816	ORIFICE, IR FRONT, 1.55mm, I3P(G31)	Ø
175817	ORIFICE, IR REAR, 1.61mm, I3P(G31)	Ø
175818	ORIFICE, IR FRONT, 1.40mm, I3B/P(G30)	Ø
175819	ORIFICE, IR REAR, 1.51mm, I3B/P(G30)	Ø
175545	ORIFICE HOLDER 3/8 COMP. STRGHT X BULKHEAD	Ø
175476	TUBING-TEE TO IR,KIT	Ø
175477	TUBING-TEE TO VALVE,KIT	Ø
175478	TUBING-LOWER BURNER TO VALVE,KIT	Ø



FLEXIBLE BATCH BROILER

RESTAURANT
EQUIPMENT MANUAL

Page 29 of 31

P/N	DESCRIPTION	
175534	SENSOR-LOWER BURNER	◀, Ø
175535	SENSOR-IR BURNER	◀, Ø
175536	IGNITER	◀, Ø
175537	IGNITION SUPPRESSION CABLE-IR	-
175538	IGNITION SUPPRESSION CABLE-LOWER	-
175674	CHAIN, COOK	◀, Ø
175525	BUSHING BLOCK, CONVEYOR	◀, Ø
175430	LOADER TRAY	-
175438	LOADER MOUNTING BRACKET	-
175444	LOADER	-
175741	LOADER RAMP	-
175429	DOOR	-
175293	FLAME ARRESTOR	◀, Ø
175200	BURNER SHIELD	◀, Ø
175340	DISCHARGE CHUTE	-
175778	DISCHARGE HOOD	-
175363	PRODUCT PAN SHELF	-
175358	DISCHARGE PAN	-
175329	MAIN GREASE PAN	-
175325	"V" GREASE PAN	-
175357	SIDE, GREASE PAN	-
175150	PIVOT ASH SCRAPER	-
175305	REAR PANEL	-
175300	FRONT PANEL	-
175392	PANEL,UPPER,LIFT OFF	-
175383	PANEL, ACCESS ELECTRICAL LWB	-
175250	PANEL ACCESS DISCHARGE	-
175226	IMPEDANCE PAN (IF NO OPTIONAL CATALYST)	◀, Ø
175480	CATALYST (OPTIONAL)	-
175482	CATALYST, GUARD	-
175485	TUBE BURNER CLEANING TOOL	◀, Ø
175701	FLAME ROD TUBE CLEANER	◀, Ø
175705	BRUSH, FLAME ROD TUBE CLEANER	◀, Ø



FLEXIBLE BATCH BROILER

RESTAURANT
EQUIPMENT MANUAL

VI. Wiring Schematic

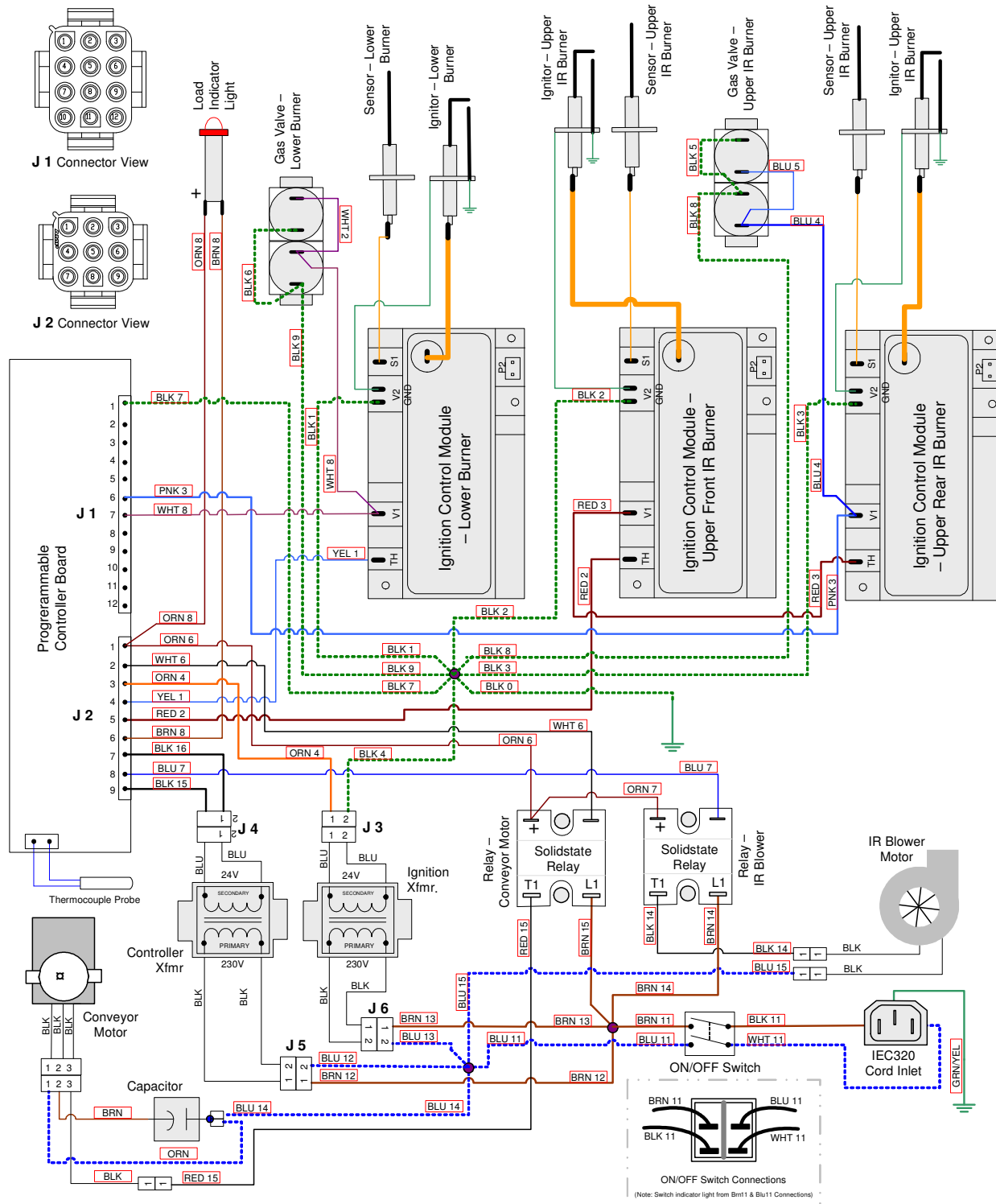



VII. Customer Assistance

To aid in reporting this unit in case of loss or theft, please record below the model number and serial number located on the unit. We also suggest you record all the information listed and retain for future reference.

MODEL NUMBER	SERIAL NUMBER
DATE OF PURCHASE	
DEALER	TELEPHONE
SERVICER	TELEPHONE

TO PHONE:

United States

Duke Manufacturing Co.
2305 North Broadway
St. Louis, MO 63102 USA
Dial 1-800-735-DUKE (1-800-735-3853)

Europe

Duke Manufacturing C.R. S.R.O.
Vltavska 219
Stechovice, 25207 Czech Republic
Dial +49 (0) 911 894-6702

Duke Manufacturing UK Ltd.
The Granary Westpoint
Clyst-St.Mary
Exeter Devon EX5 1DJ
United Kingdom
Dial +44 (0) 844 561-6610

For SERVICE, PARTS ORDER, or ADDITIONAL CUSTOMER INFORMATION

TO ACCESS INTERNET: www.dukemfg.com

Please provide the following information when you write or call: model number, serial number, date of purchase, your complete mailing address (including zip code), and description of the problem.