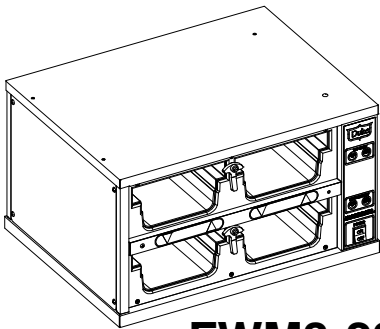


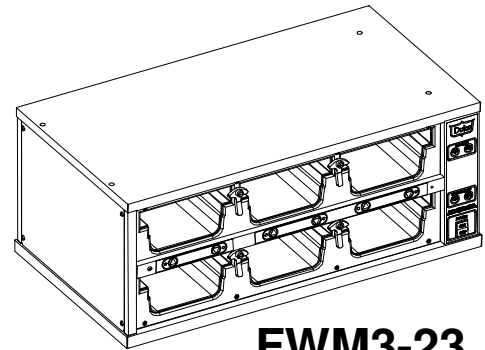
Operators and Service Manual

Product Holding Cabinet

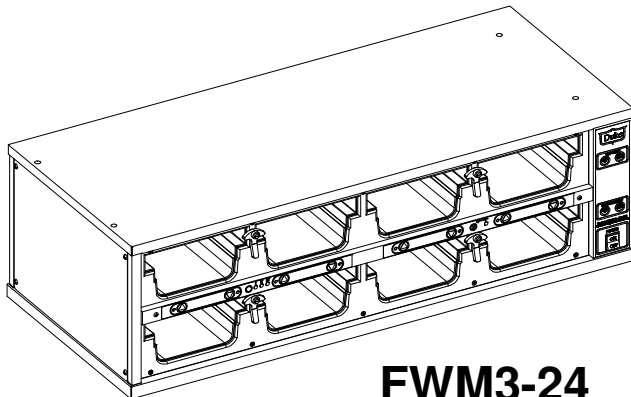
U.S. Patent 6175099, 6262394
Other U.S. and Foreign Patents Pending



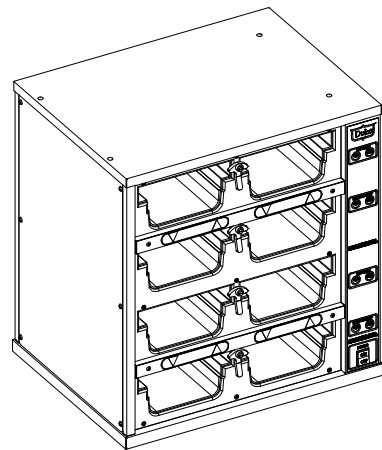
FWM3-22



FWM3-23



FWM3-24



FWM3-42

For information or technical assistance, call:

TOLL FREE

(800) 735-DUKE (3853)

or

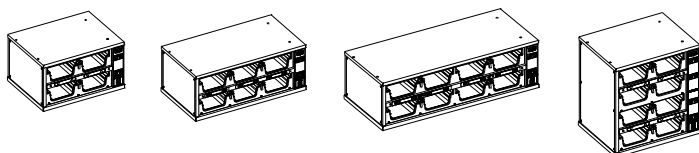
(314) 231-1130

This Page Intentionally Left Blank

TABLE OF CONTENTS

Manufacturer's Introduction3
Specification Sheet.....4
Installation Instructions.....8
Stacking Units8
Unit to Unit Communication Connections9
Periodic Maintenance, Checklist And Cleaning Guide10
Troubleshooting.....11
Electronic Control Fault Indications11
Temperature Check Procedure.....11
Control Programming.....12
Parts Lists And Illustrations13
Wiring Schematic.....15

Manufacturer's Introduction



The Duke Product Holding Unit was developed for extended food-holding capabilities to provide consistently high, "just cooked" food quality.

The Duke Product Holding Unit utilizes Duke's patented "heat sink" holding technology that provides even heat distribution to food pans through the bottom and sides. This allows pre-cooked foods to be held for extended periods without noticeable degradation of quality, reducing food scrap/waste.

The self contained, individually formed, sealed compartments of the Duke Product Holding Unit eliminates food odor and taste transfer. Because the compartments are sealed and formed to the shape of the pan, no disassembly is required for cleaning and product changes.

The unique design of the Duke Product Holding Unit allows single temperature operation for all existing product groups. This 190°F approved temperature is preset at the factory. This reduces the likelihood of inconsistent performance between restaurant locations.

The Duke Product Holding Cabinet was also designed to rethermalize food product. A thermostat setting of 200°F minimum is required for rethermalization. See instructions on page 12 for thermostat adjustment.

Supplier Name: **Duke Manufacturing Co.**
 Address: 2305 N. Broadway
 St. Louis, MO 63102

Model #:	FWM3-22-100	FWM3-24-100
	FWM3-22-120	FWM3-24-120
	FWM3-22-208	FWM3-24-208
	FWM3-22-230	FWM3-24-230
	FWM3-22-240	FWM3-24-240
	FWM3-23-120	FWM3-42-100
	FWM3-23-208	FWM3-42-120
	FWM3-23-230	FWM3-42-208
	FWM3-23-240	FWM3-42-230
		FWM3-42-240

Serial #: _____
 Date Received: _____
 Date Installed: _____
 Telephone: (800) 735-DUKE (3853)
 (314) 231-1130
 Fax: (314) 231-5074
 Service Referral #:
 Local Service
 Name _____

 Local Service # _____

Installation requirements

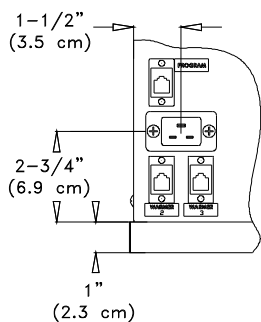
Power Connection:
 See diagrams on pages 2-5.

!CAUTION!
Risk of fire or electric shock. Replace only with Manufacturer's cord set or equivalent.

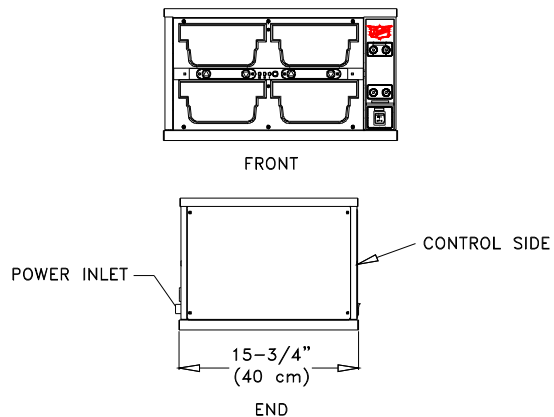
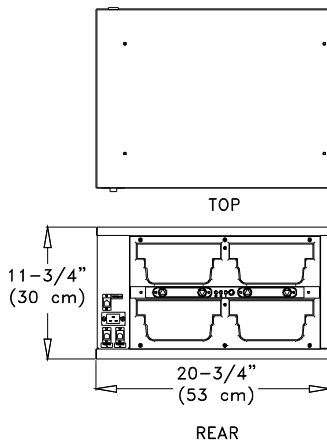
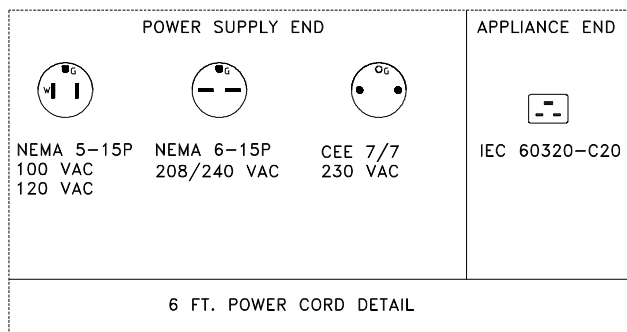


**Figure 1.1, FWM Specification Sheet
Model FWM3-22**

Shipping Weight:	61 lbs/27.7 Kg	
Electrical:	FWM3-22-100 FWM3-22-120 FWM3-22-208 FWM3-22-230 FWM3-22-240	100V, 8.0 A, 800 W, 50/60 Hz 120 V, 6.7 A, 800 W, 50/60 Hz 208 V, 5.8 A, 1200 W, 50/60 Hz 230 V, 5.2 A, 1200 W, 50/60 Hz 240 V, 5.0 A, 1200 W, 50/60 Hz



APPLIANCE INLET DETAIL



ALSO CLASSIFIED BY
UNDERWRITERS LABORATORIES INC.
IN ACCORDANCE WITH
NSF NO. 4 1999

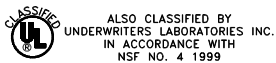
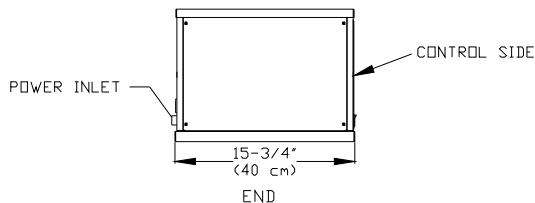
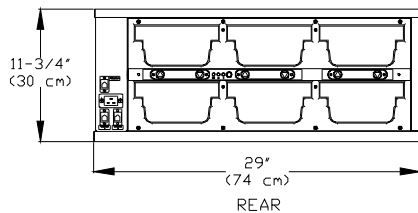
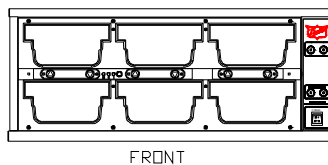
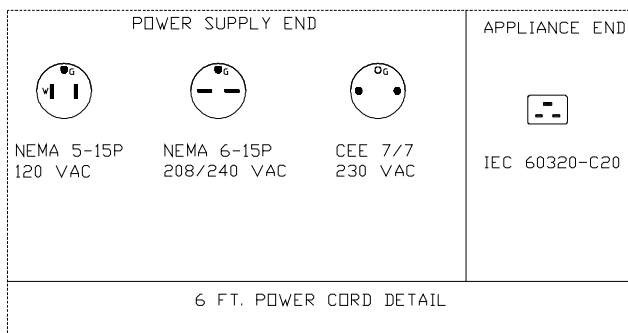
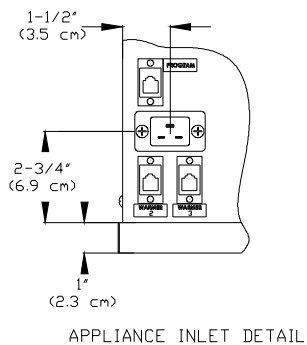


U.S. Patent 6175099, 6262394
Other U.S. and Foreign Patents Pending
DUKE MANUFACTURING CO.
TOLL FREE 800-735-DUKE (3853)
314-231-1130



**Figure 1.2, FWM Specification Sheet
Model FWM3-23**

Shipping Weight:	83.5 lbs/37.9 Kg	
Electrical:	FWM3-23-120 FWM3-23-208 FWM3-23-230 FWM3-23-240	120 V, 10.0 A, 1200 W, 50/60 Hz 208 V, 8.7 A, 1800 W, 50/60 Hz 230 V, 7.8 A, 1800 W, 50/60 Hz 240 V, 7.5 A, 1800 W, 50/60 Hz

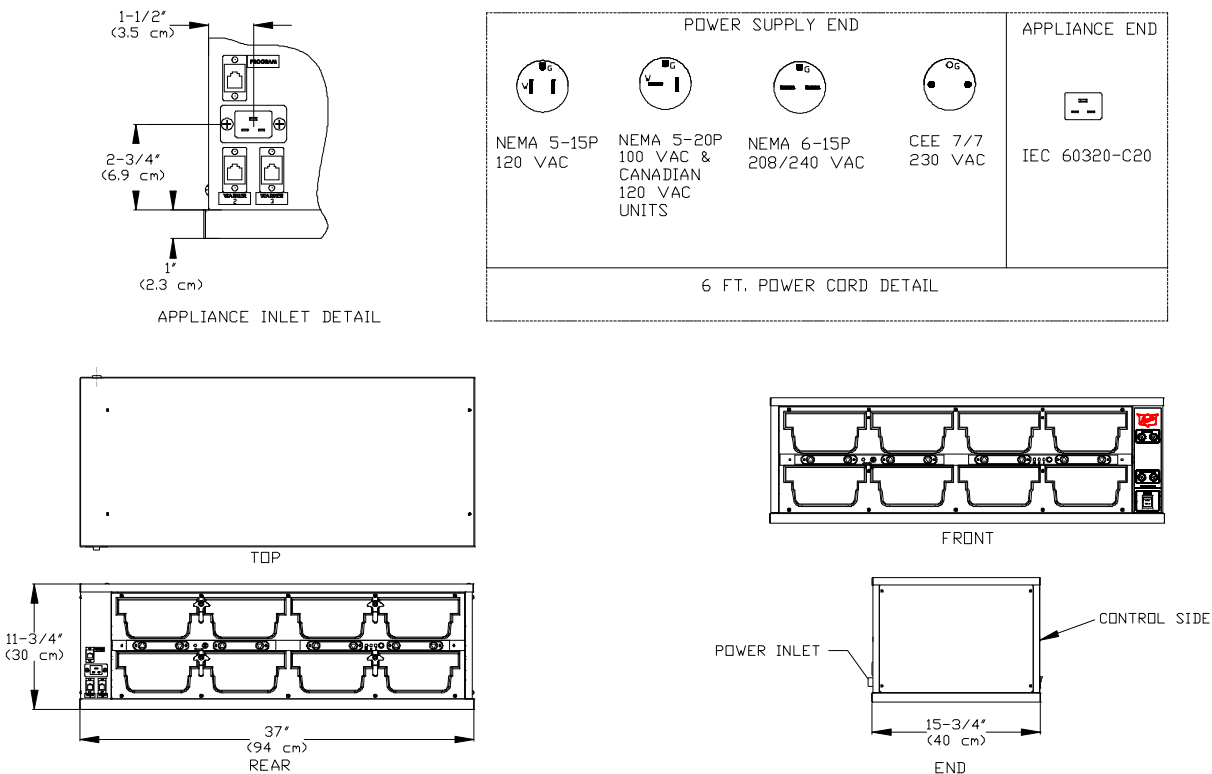


U.S. Patent 6175099, 6262394
Other U.S. and Foreign Patents Pending
DUKE MANUFACTURING CO.
TOLL FREE 800-735-DUKE (3853)
314-231-1130



**Figure 1.3, FWM Specification Sheet
Model FWM3-24**

Shipping Weight:	100 lbs/45 Kg	
Electrical:	FWM3-24-100 FWM3-24-120 FWM3-24-208 FWM3-24-230 FWM3-24-240	100 V, 16.0 A, 1600 W, 50/60 Hz 120 V, 13.3 A, 1600 W, 50/60 Hz 208 V, 11.5 A, 2400 W, 50/60 Hz 230 V, 10.4 A, 2400 W, 50/60 Hz 240 V, 10.0 A, 2400 W, 50/60 Hz



ALSO CLASSIFIED BY
UNDERWRITERS LABORATORIES INC.
IN ACCORDANCE WITH
NSF NO. 4 1999

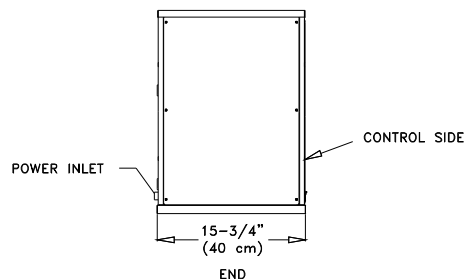
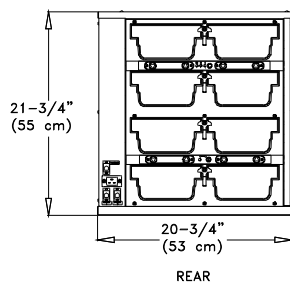
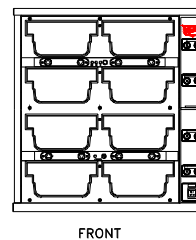
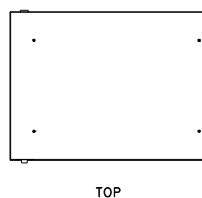
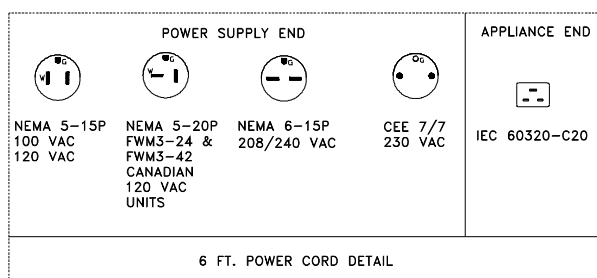
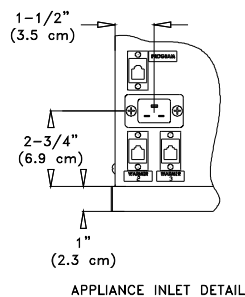


U.S. Patent 6175099, 6262394
Other U.S. and Foreign Patents Pending
DUKE MANUFACTURING CO.
TOLL FREE 800-735-DUKE (3853)
314-231-1130



**Figure 1.4, FWM Specification Sheet
Model FWM3-42**

Shipping Weight:	100 lbs/45 Kg	
Electrical:	FWM3-42-100 FWM3-42-120 FWM3-42-208 FWM3-42-230 FWM3-42-240	100 V, 16.0 A, 1600 W, 50/60 Hz 120 V, 13.3 A, 1600 W, 50/60 Hz 208 V, 11.5 A, 2400 W, 50/60 Hz 230 V, 10.4 A, 2400 W, 50/60 Hz 240 V, 10.0 A, 2400 W, 50/60 Hz



ALSO CLASSIFIED BY
UNDERWRITERS LABORATORIES INC.
IN ACCORDANCE WITH
NSF NO. 4 1999

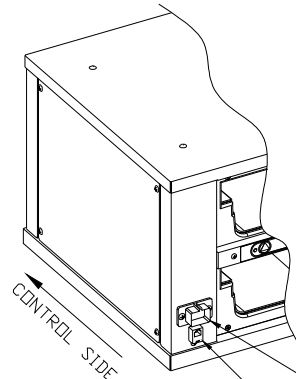


U.S. Patent 6175099, 6262394
Other U.S. and Foreign Patents Pending
DUKE MANUFACTURING CO.
TOLL FREE 800-735-DUKE (3853)
314-231-1130



Installation Instructions

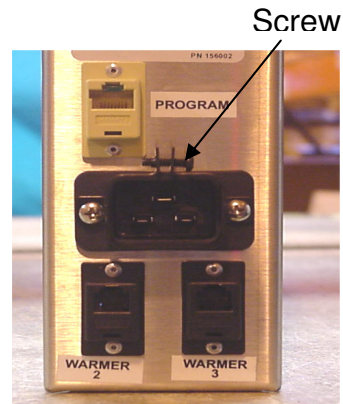
1. Place warmer module onto stable surface.
2. Attach power supply cord to IEC 60320 C20 using approved cordset.
3. Follow instructions in the Operators Manual PERIODIC MAINTENANCE, CHECKLIST AND CLEANING GUIDE.



!CAUTION!

Risk of fire or electric shock. Replace cord with one of the following Duke cordsets only:

- P/N 156533 Cordset, NEMA 5-15P, 120 V
- P/N 156811 Cordset, NEMA 5-20P, 120 V Canadian FWM3-24 & FWM3-42 units
- P/N 156421 Cordset, NEMA 6-15P, 208/240 V
- P/N 156400 Cordset, 230 V CE

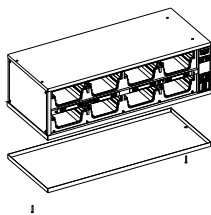


The proper way to connect the power cord is to loosen the screw, push the cord fully into the holder and then retighten the screw.

Stacking Units

The FWM3-24 Product Holding Cabinet is designed to allow limited stacking capabilities. This section outlines how to safely stack the holding cabinet.

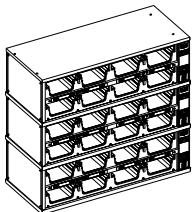
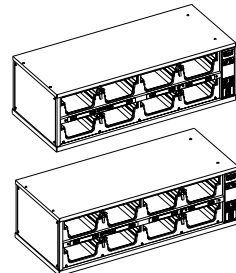
Step 1



Remove the base pan from all holding cabinets, except for bottom unit, that are to be stacked. The pan is held in place by two screws on the bottom of the unit.

Step 2

Place bottom unit into position then stack the next unit on top. The top of the lower holding cabinet rests inside of the base of the upper unit.



WARNING!

TIP HAZARD! Do not stack FWM3-42 units. Do not exceed 3 holding cabinets per stack. Do not place holding cabinet stacks on surfaces that may easily tip over.



Unit to Unit Communication Connections

Each unit with an ICC Timer Control can control up to two additional units (those without ICC Timer Control). The following are the field connections for these units. The program connection is used with the ICC provided Palm Pilot programming device.

NOTE: Product Holding Cabinets with digital keyboard timer can only use up to a maximum of four digital keyboard combinations.

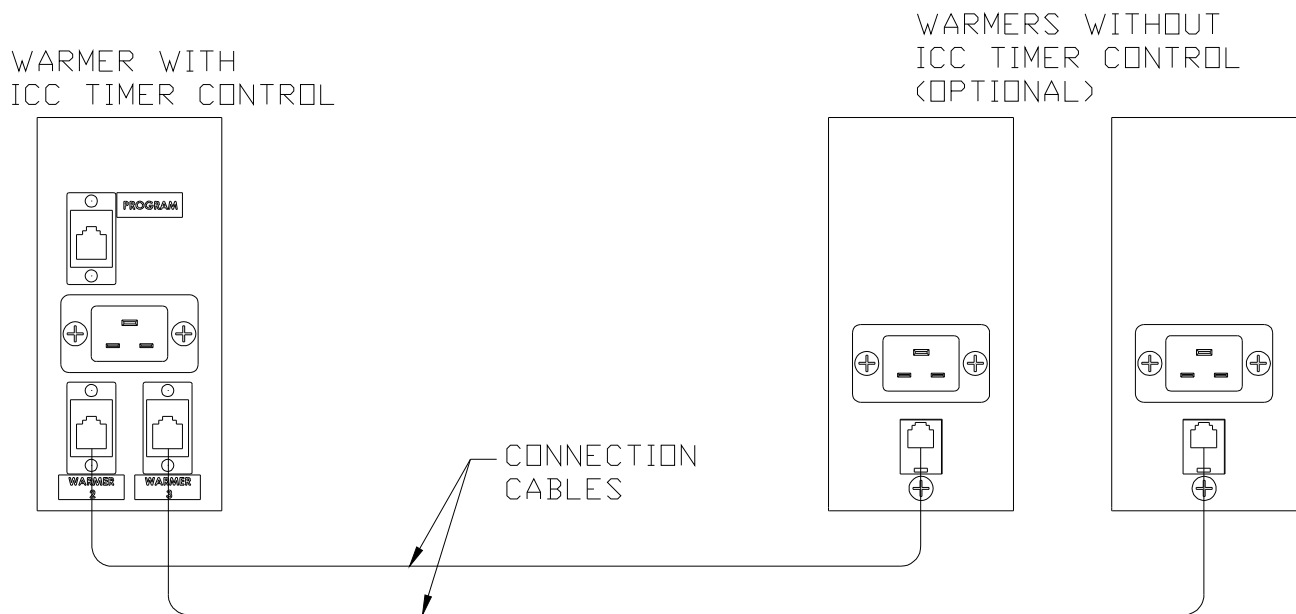


Figure 2



Periodic Maintenance, Checklist And Cleaning Guide

DAILY



Opening Checklist

1. Ensure proper **Pan Covers** are inserted into the correct locations for fried and broiled products.
2. Place the **Power Switch**, located on the front of the Product Holding Cabinet, to the ON position.
3. Ensure both top and bottom **HEAT Lights** are illuminated.
4. Allow the Product Holding Cabinet to heat for at least 20 min. or until the **HEAT Lights** cycle off.



Operation Instructions/Adjustments

1. If the **SERVICE Light** illuminates during operation of the Product Holding Cabinet, discontinue use of the affected shelf until the module is serviced.
2. Operate using Menu Bar as outlined in the Menu Scoreboard Operators Manual.



Closing Checklist

1. Turn power switch OFF.
2. Remove all pans and pan covers.
3. Allow to cool for approximately 30 minutes.
4. Clean Product Holding Cabinet as outline in the Daily Cleaning Instructions.



Cleaning Instructions

1. Wipe down the interior and exterior of the Product Holding Cabinet with warm water and mild detergent using a soft cloth. Do not use excessive amounts of water.
2. Clean pans and pan covers using mild detergent and warm water. Ensure all soap is rinsed from plastic pans and pan covers.

Caution!

**Electrical shock hazard. Do not wash with water jet or hose.
Do not use caustic cleaners, acids, ammonia products or abrasive cleaners or
abrasive cloths. These can damage the stainless steel and plastic surfaces.**

!Warning!

Bottom and sides of warmer wells are very hot and cool slowly.



Troubleshooting

There are no user serviceable parts on the Duke Product Holding Cabinet. If a malfunction occurs, ensure unit is plugged in then check all switches and circuit breakers. If the malfunction still exists, contact your Duke Manufacturing Company authorized service agent or call 1-800-735-3853.

Electronic Control Fault Indications

The Service Light is located on the front of the control next to the heat light (see Figure 3). It provides an indication to alert the operator to failures in the heater circuit. When a Service Light is on, the affected shelf should not be used until the cause of the fault is corrected by a qualified service technician. The fault conditions that could cause the control to turn the service light on are as follows:

1. **Over – Temperature Fault** - An over-temperature fault occurs when the control senses that the shelf temperature is higher than the specified factory preset temperature. This occurs when the power is not removed from the heating element after the shelf has achieved the preset temperature, causing the control to turn on the service light. The auxiliary thermostat prevents the temperature from exceeding safe levels by regulating the temperature to a maximum of 250° F.
2. **Under – Temperature Fault** - An under-temperature fault occurs when the control senses that the shelf temperature is lower than the specified factory preset temperature for more than 30 minutes continuously. This occurs when heating element circuit opens or the RTD Feedback signal is faulty, causing the control to turn on the service light.

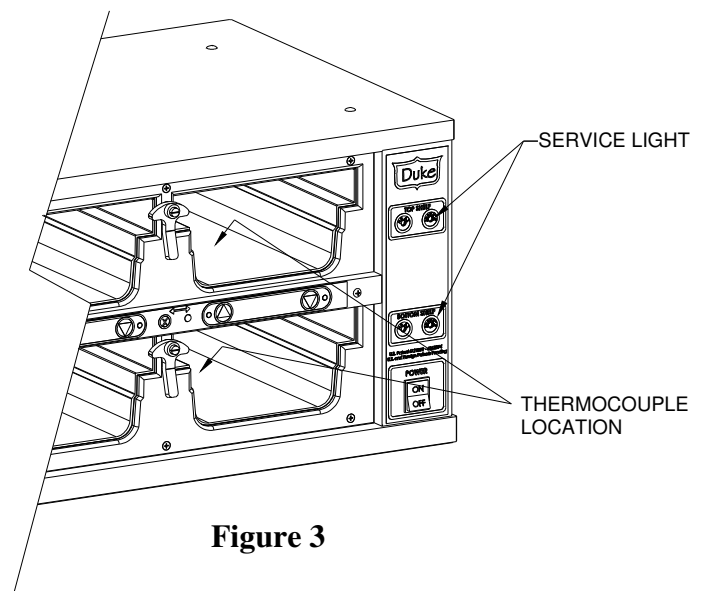


Figure 3

Temperature Check Procedure

1. A digital temperature meter that has been calibrated must be used to get an accurate temperature reading. Use a thermocouple surface temperature probe to measure temperatures.
2. **No pans should be in wells during the pre-heat and temperature check.** Pre-heat the warmer for 30 minutes before taking any temperature readings. Do not take readings unless the cavity has been empty for 30 minutes. This will allow the temperature to stabilize and will prevent false readings.
3. The warmer cavity should be cleaned and empty before the temperature is checked. Avoid any air drafts that might flow through the cavity.
4. Locate the surface temperature probe on the bottom of the first cavity in the geometric center. The first cavity is the one closest to the control panel (see Figure 3). Make sure the probe is making good contact with the surface while taking readings.
5. All temperature controls exhibit a swing in temperature as the control cycles on and off while regulating to the set point. The correct calibration temperature is the average of several readings taken over a period of 20 minutes after the warmer has been pre-heated. The average temperature should be $\pm 5^{\circ}\text{F}$ from the set point.

Control Programming

The electronic temperature control is pre-set at the factory to maintain the temperature at the bottom center of the pan cavity +/- 5° F. This temperature is the result of many hours of laboratory food testing. There are no operator temperature adjustments that can be made. Because the electronic control uses a platinum type RTD sensor, routine calibration is not required.

**! DANGER!
LIVE ELECTRICAL COMPONENTS.
ONLY QUALIFIED SERVICE PERSONS SHOULD MODIFY CONTROL
TEMPERATURE PRESETS.**

Temperature Programming

1. Remove cover from control side of the Holding Cabinet and turn the Holding Cabinet on.
2. Locate the pushbutton S1 and S2 on the rear of the control. (see Figure 4.1)
3. Press and hold S1 until any LED on the rear of the control illuminates. (approximately 5 seconds)
4. Observe the front of the control (Figure 4.2). Press and release S1 on the back of the control until the desired light on the front of the control flashes. (see Table 1)

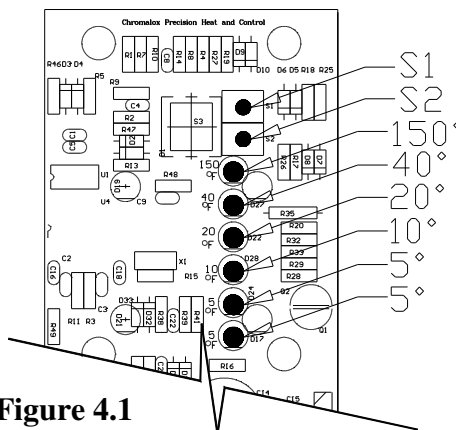


Figure 4.1

NOTE: To comply with NSF sanitation requirements, do not set the control preset temperature below 180° F.

5. Press and release S2 until the sum of the LED values illuminated on the rear of the board match the desired pre-set temperature.
6. Repeat steps 4 and 5 for each pre-set temperature then press and hold S1 until no LED on the rear of the control is illuminated and the lights on the front of the board no longer flash.
7. Replace cover on control side of the Holding Cabinet.

Flashing Lights		
	A	B
Top Shelf	X	
Bottom Shelf		X

TABLE 1

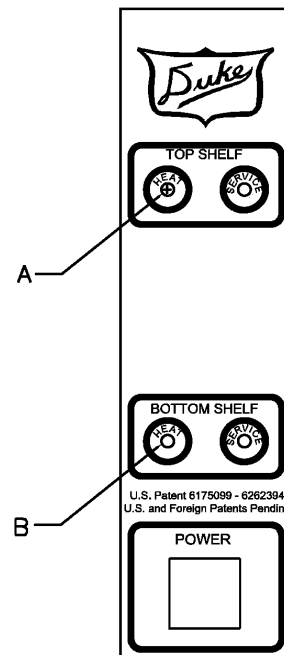


Figure 4.2



PRODUCT HOLDING CABINET

RESTAURANT EQUIPMENT MANUAL

Parts Lists and Illustrations

Locator	P/N	Description	Qty Per Unit			
			FWM3-22	FWM3-23	FWM3-24	FWM3-42
1	156807 156677 156279 156808 156676 156672 157532 157539 156756 156908	PAN STATUS KEYBOARD FWM3-22, DAYPART PAN STATUS KEYBOARD FWM3-22, DIGITAL PAN STATUS KEYBOARD FWM3-22, DIGITAL/DAYPART PAN STATUS KEYBOARD FWM3-23, DAYPART PAN STATUS KEYBOARD FWM3-23, DIGITAL PAN STATUS KEYBOARD FWM3-24, DAYPART/TRANSFER PAN STATUS KEYBOARD FWM3-24, DIGITAL/DAYPART PAN STATUS KEYBOARD FWM3-24, DIGITAL PAN STATUS KEYBOARD FWM3-42, DAYPART PAN STATUS KEYBOARD FWM3-42, DIGITAL/DAYPART	1 or 2	1 or 2	1 or 2	1 or 2
2	600106	KIT, FWM CONTROLLER	1	1	1	2
3	155749 156838	TRANSFORMER 208/240 VAC TRANSFORMER 230 VAC	1	1	1	1
	156316	TRANSFORMER 120 VAC				
4	155741	RECEPTACLE ELECTRIC	1	1	1	1
5	156616	COUPLER 6X6 RJ12 (MB1 & SB1 UNITS ONLY)	2	2	2	2
6	156617	COUPLER, 8X8 RJ45 (MB1 & SB1 UNITS ONLY)	1	1	1	1
7	156059	CONNECTOR SPECIAL T (REAR VIEW MB2 & SB2)	1	1	1	1
8	156527	SWITCH, LIGHTED, DPST, 16A	1	1	1	1
* 9	156809 156820 156819 156409 156939 156935 156610 156914 157533 156909	CONTROL, ICC TIMER, W/ SOUNDER, FWM3-22 & FWM3-23 CONTROL, ICC TIMER, W/ SOUNDER, FWM3-24 & FWM3-42 CONTROL, ICC TIMER, W/O SOUNDER, FWM3-22 & FWM3-23 CONTROL, ICC TIMER, W/O SOUNDER, FWM3-24 & FWM3-42 CONTROL, ICC TIMER, W/100 DB SOUNDER, FWM3-22 & FWM3-23 CONTROL, ICC TIMER, W/100 DB SOUNDER, FWM3-24 & FWM3-42 CONTROL, ICC TIMER, DIGITAL, W/ SOUNDER, FWM3-22 & FWM3-23 CONTROL, ICC TIMER, DIGITAL/DAYPART, W/SOUNDER, FWM3-22,23 CONTROL, ICC TIMER, DIGITAL/DAYPART, W/SOUNDER, FWM3-24 CONTROL, ICC TIMER, DIGITAL/DAYPART, W/SOUNDER, FWM3-42	1	1	1	1
10	156485 156558 155849 156548	FACE PLATE WITH GASKET, FWM3-22 FACE PLATE WITH GASKET, FWM3-23 FACE PLATE WITH GASKET, FWM3-24 FACE PLATE WITH GASKET, FWM3-42	2	2	2	2
11	156285	LATCH,PAN	4	8	8	8
12	156288	SCREW SHOULDER	4	8	8	8
13	0653638	SCREW 1/4-20 X 3/4	8	8	8	16
14	155750	RTD 1K OHM THIN	2	2	2	4
15	156994 156483 156539 156632 156540 156564 156301 156611 156565 157520 156566 155752 156318 155755	ELEMENT FOIL HEAT FWM3-22-100 & FWM3-42-100 ELEMENT FOIL HEAT FWM3-22-120 & FWM3-42-120 ELEMENT FOIL HEAT FWM3-22-208 & FWM3-42-208 ELEMENT FOIL HEAT FWM3-22-230CE & FWM3-42-230CE ELEMENT FOIL HEAT FWM3-22-240 & FWM3-42-240 ELEMENT FOIL HEAT FWM3-23-120 ELEMENT FOIL HEAT FWM3-23-208 ELEMENT FOIL HEAT FWM3-23-230CE ELEMENT FOIL HEAT FWM3-23-240 ELEMENT FOIL HEAT FWM3-24-100 ELEMENT FOIL HEAT FWM3-24-120 ELEMENT FOIL HEAT FWM3-24-208 ELEMENT FOIL HEAT FWM3-24-230CE ELEMENT FOIL HEAT FWM3-24-240	4 4 4 4 4 4 6 6 6 6 4 6 6 6 8 8 8 8 8			8 8 8 8 8 8 8 8 8 8 8 8 8 8 8
16	155753	THERMOSTAT AUXILIARY	2	2	2	4
17	155680	NUT #8-32 KEPS	4	4	4	8
18	155873	LID,FOODWARMER VENTED (FRIED)(GRAY)	AR	AR	AR	AR
19	155876	LID,FOODWARMER SOLID (BROILED)(BLACK)	AR	AR	AR	AR
20	156491 156666	CABLE, 8 FT, (FOR INTERCONNECTING UNITS)(NOT SHOWN) CABLE, 26 " (FOR INTERCONNECTING DIGITAL UNITS)(NOT SHOWN)	AR	AR	AR	AR
21	156533 156811 156421 156400	CORDSET, NEMA 5-15P, 120V (NOT SHOWN) CORDSET, NEMA 5-20P, 120V, CANADIAN FWM3-24,-42 (NOT SHOWN) CORDSET, NEMA 6-15P, 208/240V (NOT SHOWN) CORDSET, 230V CE (NOT SHOWN)	1	1	1	1
22	156938	TERMINAL BLOCK	1	1	1	1

* Note: These ICC Timer Controls will need to be manually programmed at the time of installation.

U.S. Patent 6175099, 6262394
Other U.S. and Foreign Patents Pending
DUKE MANUFACTURING CO.
TOLL FREE 800-735-DUKE (3853)
314-231-1130



Parts Lists and Illustrations (Continued)

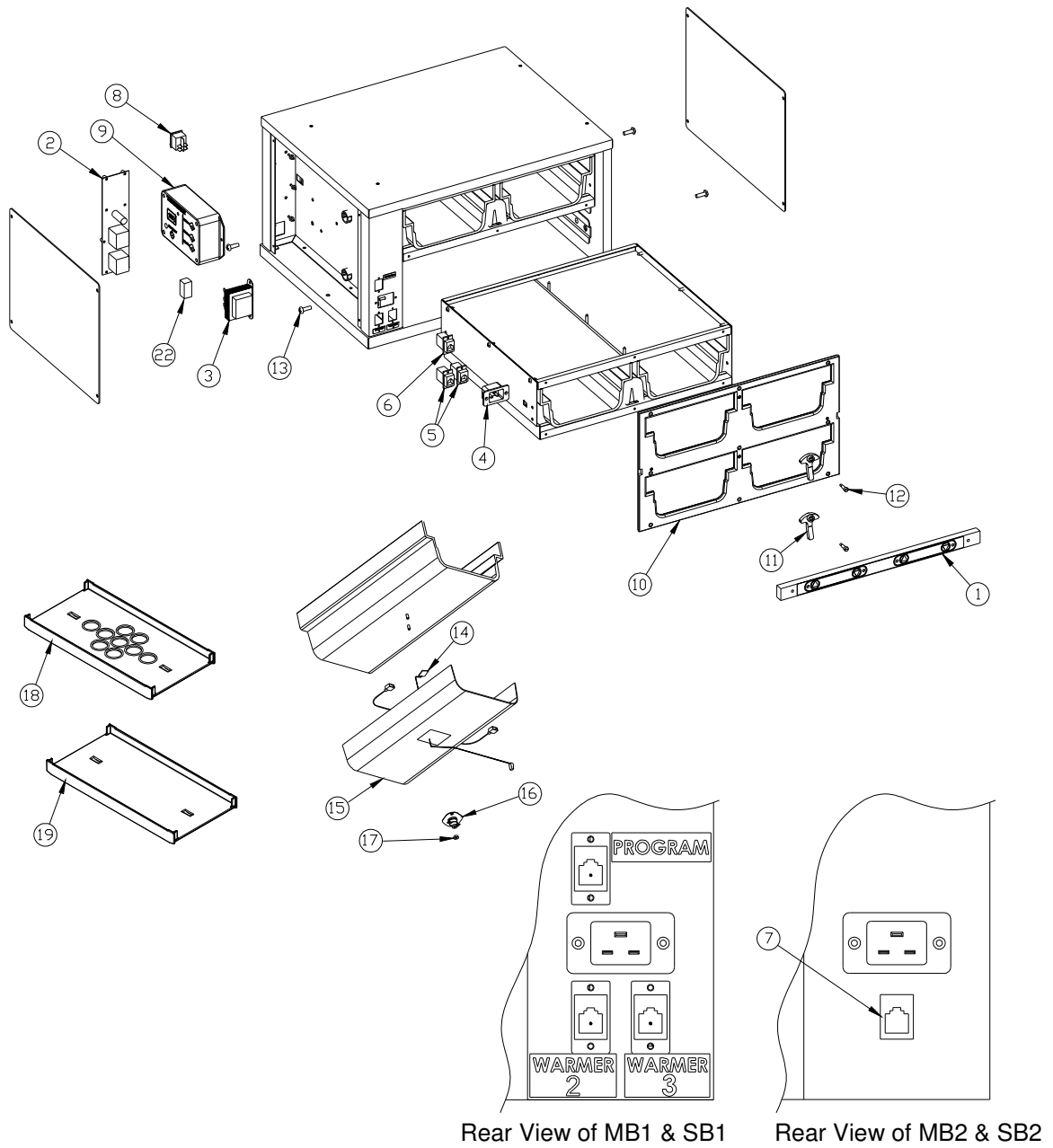
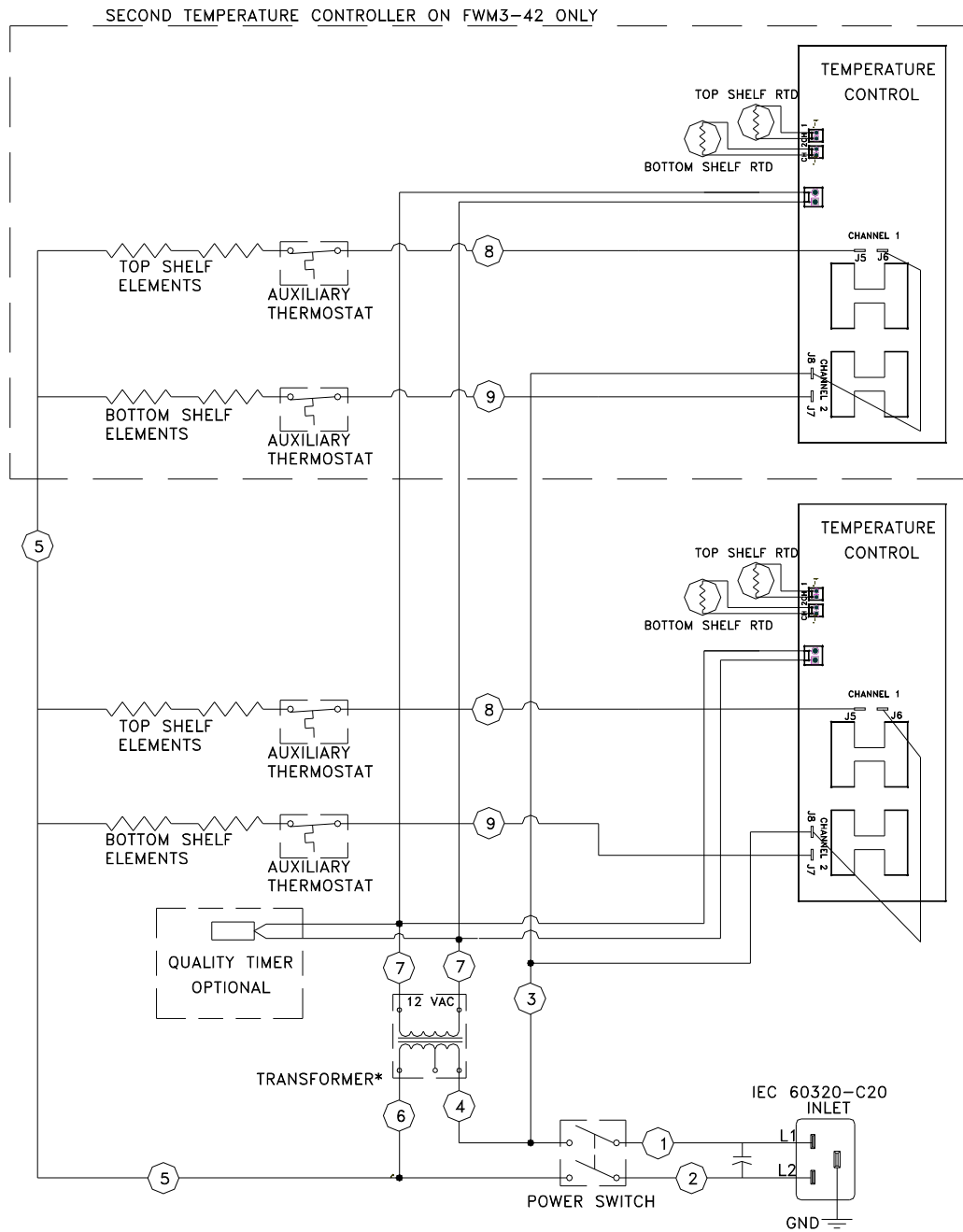


Figure 5, FWM Product Holding Cabinet Exploded View



Wiring Schematics



* CONNECT WIRE #4 TO 240V TERMINAL FOR 240VAC AND 230VAC CE UNITS (SHOWN)
CONNECT WIRE #4 TO 208V TERMINAL FOR 208 VAC UNITS
120 VAC UNITS USE A 120V TRANSFORMER

Figure 6, FWM Internal Wiring Schematic

U.S. Patent 6175099, 6262394
Other U.S. and Foreign Patents Pending
DUKE MANUFACTURING CO.
TOLL FREE 800-735-DUKE (3853)
314-231-1130



Wiring Schematics (Continued)

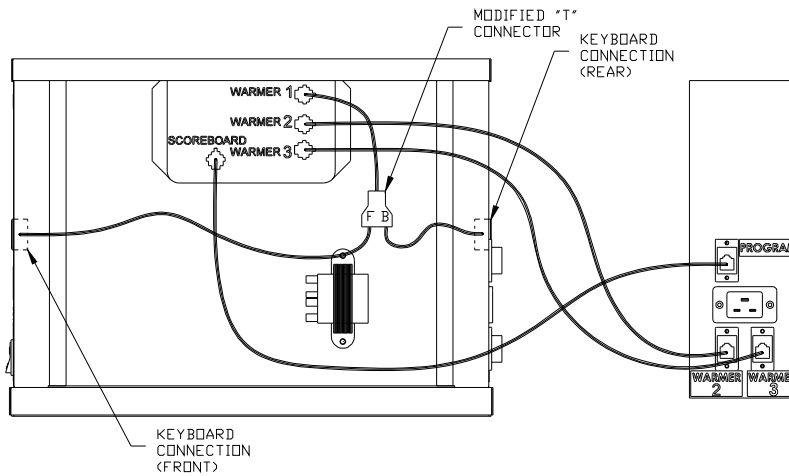


Figure 7.1, Interface Cable Schematic with ICC Timer Control

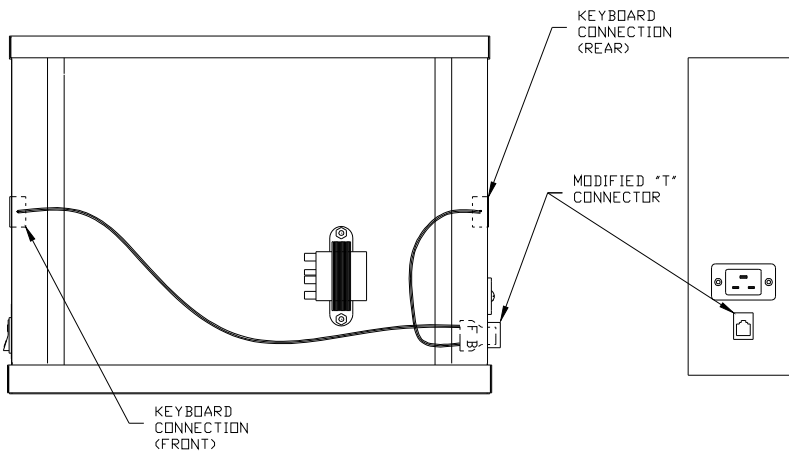


Figure 7.2, Interface Cable Schematic without ICC Timer Control



FWM3-42 Wiring Schematics

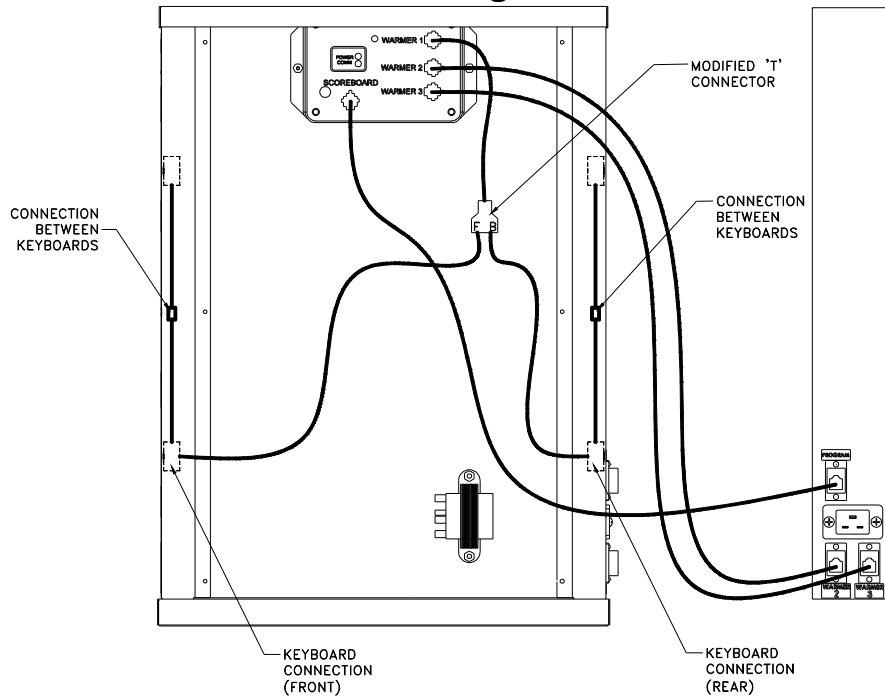


Figure 7.3 FWM3-42 Interface Cable Schematic with ICC Timer Control

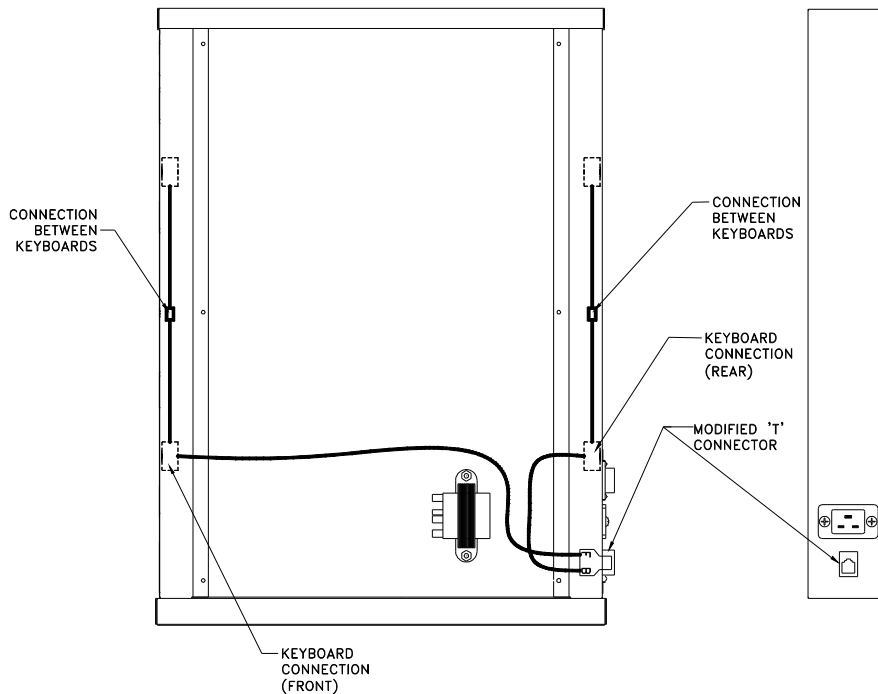


Figure 7.4 FWM3-42 Interface Cable Schematic without ICC Timer Control



This Page Intentionally Left Blank

This Page Intentionally Left Blank

