



"Your Solutions Partner"

Duke Manufacturing
2305 N. Broadway
St. Louis, MO 63102
800-735-3853

INSTRUCTIONS FOR REPLACING FWM3-51 TEMPERATURE CONTROL BOARD



DANGER: Hazardous voltage. Disconnect power before servicing machine. Risk of Electrical Shock. Can cause injury or death.



1. Remove power cord by loosening small screw and pulling out cord.



2. Remove panel from power side of unit. (Six (6) screws)

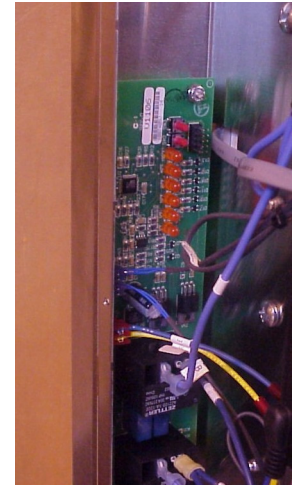

3. Remove all wires from back of control board.



4. Remove the 3 nuts that secure the control board to the cabinet. Remove temperature control board from unit.

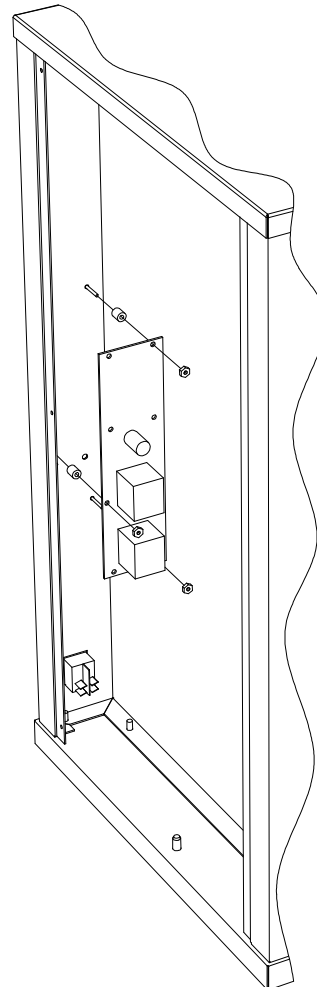

5. Replace with new temperature control board See above for spacer/nut locations.(Over)

6. Reattach wires as shown at right. Reassemble unit in reverse order.

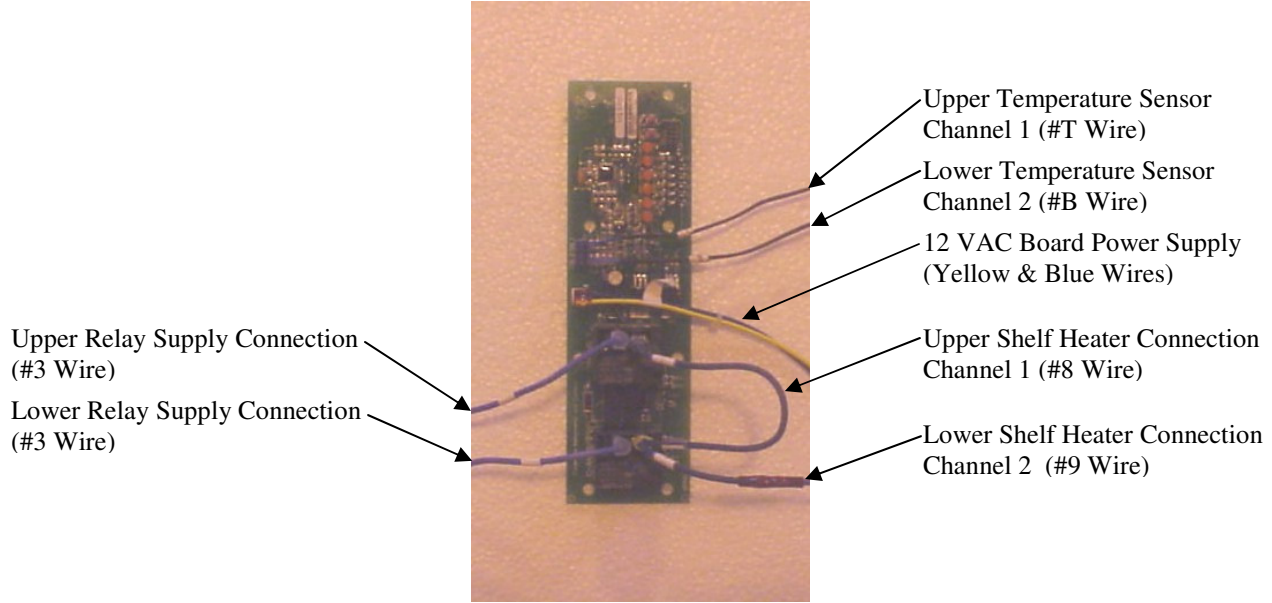

Parts Included With Kit

