



Your Solutions Partner

Installation and Operation Manual

DUKE FLEXBAKE 5™ PROOF AND BAKE OVEN

Models:
5R-DBPS

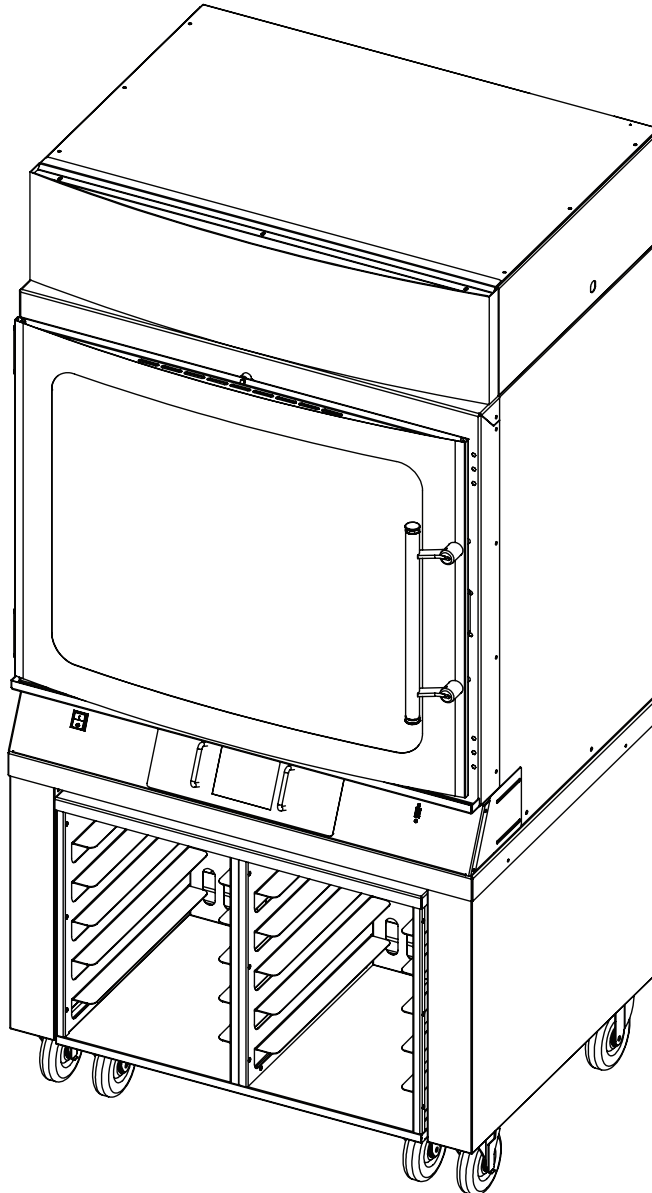

CAUTION: Please read this manual completely before attempting to install, operate or service this equipment

 **WARNING** for CA residents: go to www.dukemfg.com/prop65 for prop 65 warning

*This manual is Copyright © 2021 Duke Manufacturing Co. All rights reserved.
Reproduction without written permission is prohibited. Duke is a registered
trademark of the Duke Manufacturing Co.*

**P/N 514100
REV H 02/15/2021**



TABLE OF CONTENTS

INTRODUCTION.....3
IMPORTANT SAFETY INSTRUCTIONS4
SPECIFICATIONS.....6
MAIN FEATURES.....8
INSTALLATION9
OPERATING INSTRUCTIONS.....14
CARE AND CLEANING.....18
DOOR ADJUSTMENTS & GASKET MAINTENANCE19
LAMP BULB REPLACEMENT24
PROGRAMMING CONTROLS.....25
TROUBLESHOOTING30
WIRING DIAGRAM31

INTRODUCTION

The Duke Flexbake 5™ Proof and Bake Oven was developed in response to the Customer's need for uniform baking capabilities and to provide consistently high, quality just-baked bread.

The Duke Flexbake 5™ Proof and Bake Oven utilizes Duke's **unique directional convection airflow technology** that provides even heat distribution and a uniform bake without the need for turning pans during the bake cycle. This enhances the quality and consistency of the baked products, reduces food scrap and waste while simplifying operating process.

The low profile oven won't block the view of menu boards and will easily roll through a standard height door. The oven door is field reversible with a drip channel on the oven cavity, which prevents water from dripping on the floor.

Full-width door on the oven helps to display and merchandise fresh baked bread to the customer.

The full-width oven will accept standard half-size or full-size sheet pans.

The TSC models feature a simple color LCD touch screen control that allows users to quickly select from pre-programmed recipes for proofing and baking. Advanced features are also included for custom recipes plus user accessible information for operating instructions and maintenance information.

IMPORTANT SAFETY INSTRUCTIONS

Throughout this manual, you will find the following safety words and symbols that signify important safety issues with regards to operating or maintaining the equipment.



Indicates a hazardous situation which, if not avoided, could result in death or serious injury.



Indicates a hazardous situation which, if not avoided, could result in minor or moderate injury.



Indicates Important Information



Indicates electrical shock hazard which, if not avoided, could result in death or serious injury and/or equipment damage.



Indicates hot surface which, if not avoided, could result in minor or moderate injury. Specifically, risk of burn from heating elements.



Indicates rotating fan blade hazard which, if not avoided, could result in minor or moderate injury.



Indicates hot surface which, if not avoided, could result in minor or moderate injury.

In addition to the warnings and cautions in this manual, use the following guidelines for safe operation of the unit.

- Read all instructions before using equipment.
- Do not attempt to defeat the grounded connector.
- Install or locate the equipment only for its intended use as described in this manual.
- Do not use corrosive chemicals, water jet equipment, or other pressurized liquid spraying equipment to clean this unit.
- This equipment should be serviced by qualified personnel only. Contact the nearest Duke authorized service facility for adjustment or repair.
- Do not block any openings on the unit.
- A minimum clearance of 6" (152.4 mm) from the top of the unit to the ceiling must be provided.
- Unit may start operation with inadvertent contact with touch screen display or from other extraneous sources. Turn off all poles mains disconnects should abnormal or unwanted operation occur.
- Install the Restraining Device Kit to prevent damage to main supply connections.

- This appliance can be used by children aged from 8 years and above and persons with reduced physical, sensory or mental capabilities or lack of experience and knowledge if they have been given supervision or instruction concerning use of the appliance in a safe way and understand the hazards involved. Children shall not play with the appliance. Cleaning and user maintenance shall not be made by children without supervision.
- Turn off external mains supply disconnect and allow unit to cool down before servicing or performing maintenance.
- The procedures in this manual may include the use of chemical products. You must read the Material Safety Data Sheets before using any of these products.
- Properly rated all poles mains protection and earthing compliance with local electric codes are required for safe operation of this unit.
- Water supply connections to the unit must comply with local plumbing code and/or standards.
- Disposal of the unit must be in accordance with local environmental codes and/or any other applicable codes.
- **SAVE THESE INSTRUCTIONS**





SPECIFICATIONS

Patent Pending
 Model 5R-DBPS

Unit Weight: Oven and Stand	550 lbs / 250 kg
Shipping Weight: Carton Box	600 lbs / 272 kg
Optional Cart:	67 lbs / 30 kg

Line Supply Voltage (Vac)	Line Supply Frequency (Hz)	Line Phase Configuration	Branch Circuit Protection Device Rating	Total Maximum Line Current Amps (A)	Total Maximum Line Power Watts (W)
208	60	1	45 A	41	8500
208	60	3P	30 A	24.4	8700
240	60	1	40 A	35	8400
240	60	3P	30 A	21	8700

Compliance Declaration - 5R-DBPS Flexbake 5™ Proof and Bake Oven

 LISTED COMMERCIAL COOKING APPLIANCE	Standard: UL197	File: KNGT.E17421
 INDEXER COMMERCIAL APPAREIL DE CUISINE	Standard: CSA-C22.2 No. 109	File: KNGT7.E17421
	Standard: ANSI / NSF 4	File: TSQT.E157479
	WEEE Directive 2002/96/EC	
	RoHS 2011/65/EU	

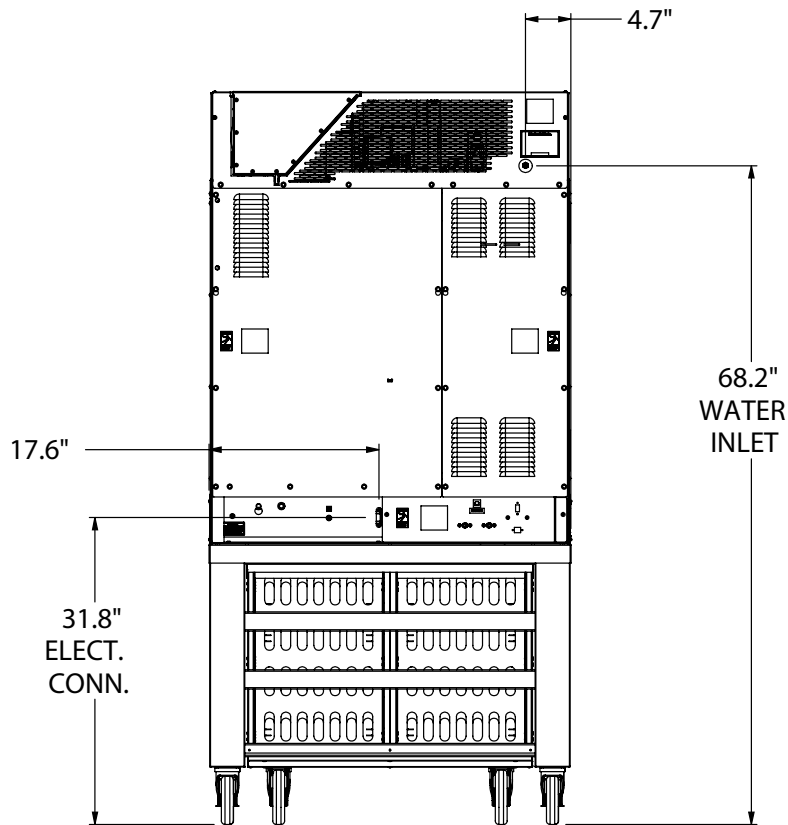
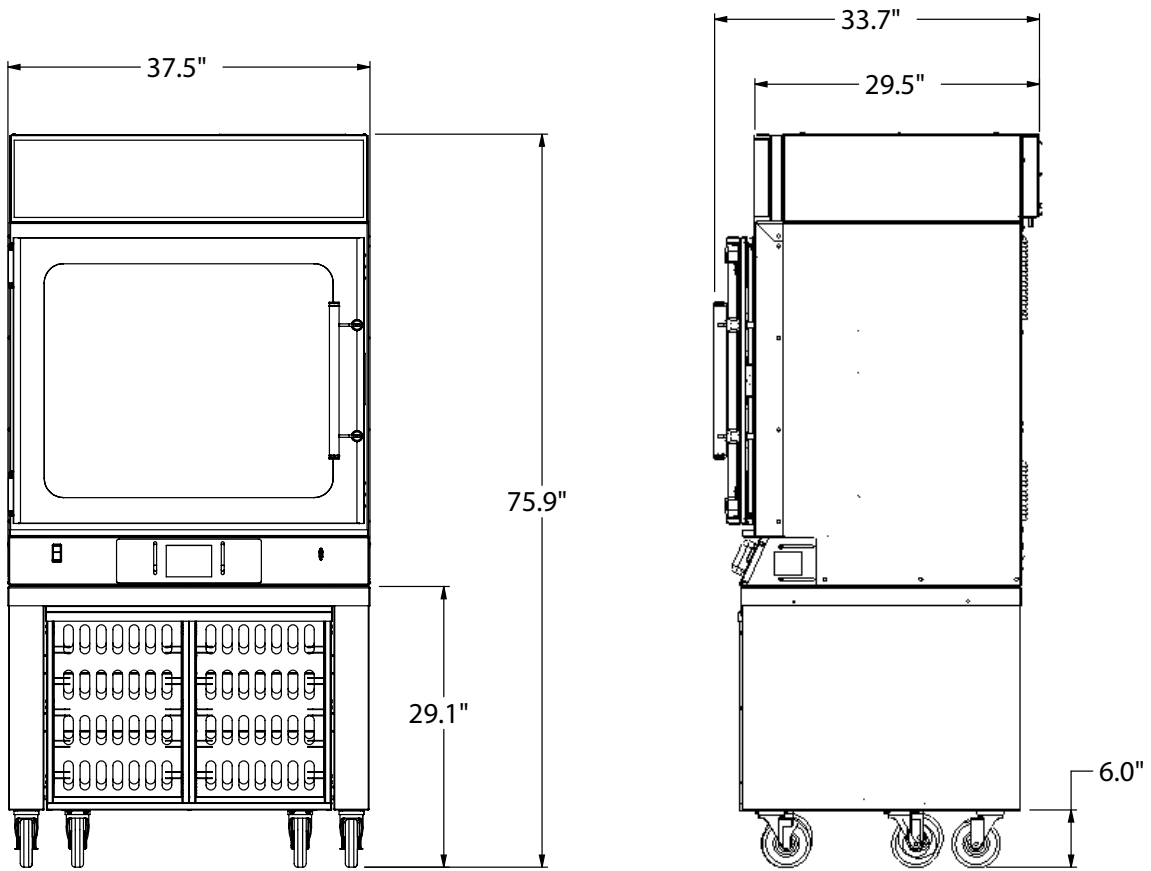

MAIN FEATURES

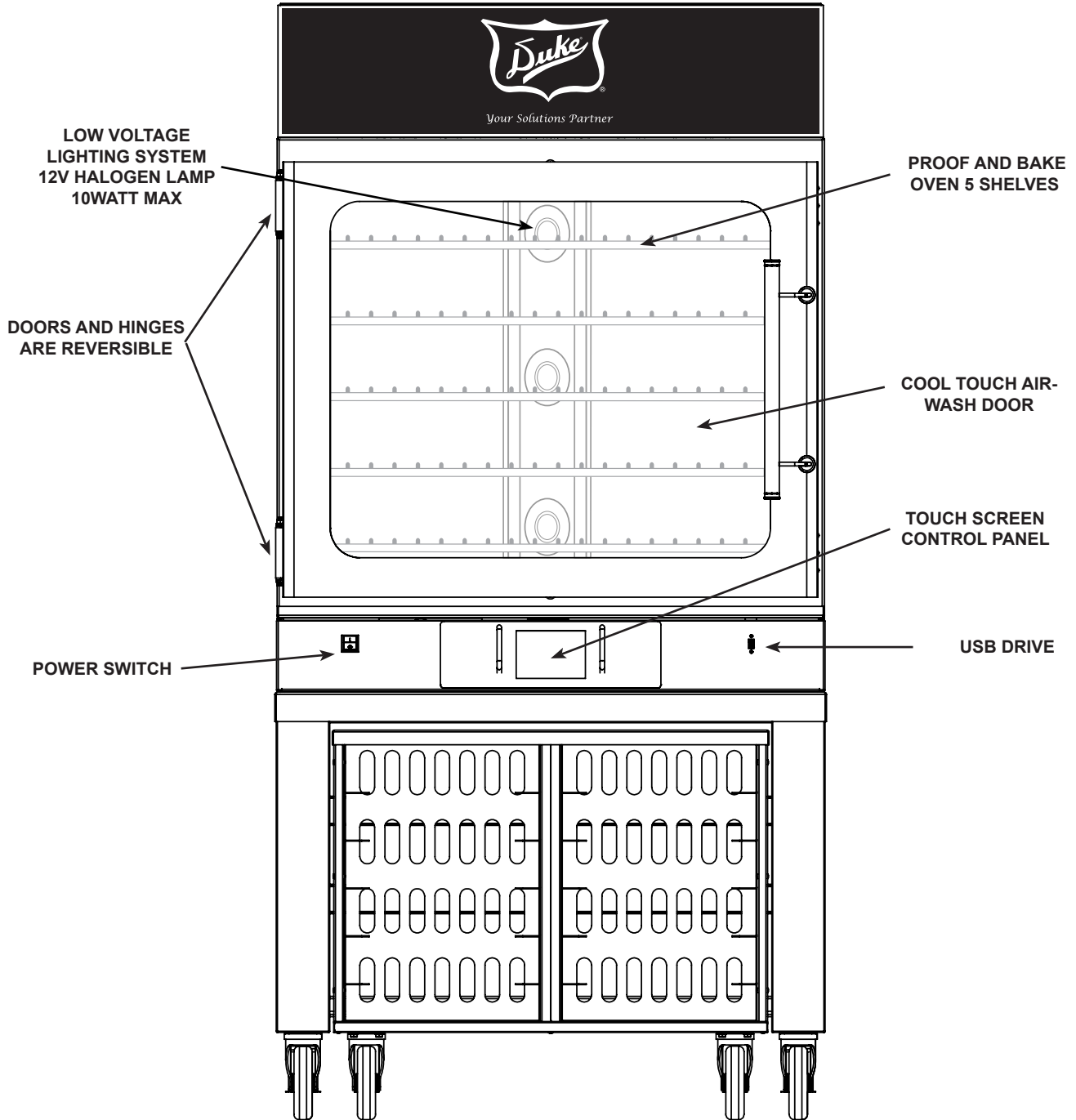

Figure: Main Features

INSTALLATION

UNPACKING UNIT

Inspect the shipping carton and/or container, carefully noting any exterior damage on the delivery receipt; also note any damage not evident on the outside of the shipping container (concealed damage). Contact the carrier immediately and file a damage claim with them. Save all packing materials when filing a claim. Freight damage claims are the responsibility of the purchaser and are not covered by the warranty.

- Follow the instructions on the Carton Box for unpacking the unit.
- Inspect unit for damage such as, broken glass, etc.
- Report any dents or breakage to source of purchase immediately.
- **Do not attempt to use unit if damaged.**
- Remove all materials from unit interior.
- If unit has been stored in extremely cold area, wait a few hours before connecting power.

UNIT PLACEMENT

- Do not install unit next to source of heat, such as deep fryer, etc.
- Install unit on level surface floor.
- Minimum Clearance of 6" (152mm) must be maintained between the unit and any combustible substance.
- Either side of the unit must remain open for proper airflow for electrical component cooling. One side may be installed without clearance. Maintain a minimum clearance of 2 inches on the rear of the unit for proper operation and cooling.



ELECTRICAL SHOCK HAZARD UNIT MUST BE SAFETY GROUNDED, EARTHED.

DO NOT MODIFY, DEFEAT ELECTRICAL CONNECTIONS OR ALTER PLUG.

ELECTRICAL CONNECTIONS

⚠ WARNING BEFORE CONNECTING THE UNIT TO THE POWER SOURCE, VERIFY THAT THE VOLTAGE AND PHASE OF THE POWER SOURCE ARE IDENTICAL TO THE VOLTAGE AND PHASE INFORMATION ON THE DATA LABEL.

⚠ WARNING ELECTRICAL AND GROUNDING CONNECTIONS MUST COMPLY WITH THE APPLICABLE PORTIONS OF THE NATIONAL ELECTRICAL CODE AND/OR OTHER LOCAL ELECTRICAL CODES.

⚠ WARNING DO NOT STORE OR USE GASOLINE OR OTHER FLAMMABLE VAPORS OR LIQUIDS IN THE VICINITY OF THIS OR ANY OTHER APPLIANCE.

⚠ WARNING THE MAIN SWITCH ON THE APPLIANCE IS FOR STANDBY POWER ONLY. FOR ALL-POLE DISCONNECT REMOVE PLUG FROM WALL OUTLET.

Connection of the unit to the mains supply **MUST** be performed by an authorized person in accordance with codes, standards, and laws governing the installation site using properly rated all poles mains protection, all poles mains disconnects, safety ground earthing, and shall be a minimum of 48" (1.2 meter) long to allow the equipment to be moved for cleaning.

USA and non-EU Countries must use flexible conduit within variances that may be required by local electric codes or regulations.

European Union (CE) installations must use HO7RN-F, 5G 2,5mm flexible cordage.

The Mains Supply safety / earth ground wire must be longer than mains conductors at the unit's interconnections to prevent stress under pull.

Contact Duke for service of IVS (Integrated Ventilation System) supply interconnection.

EXTERNAL EQUIPOTENTIAL



Terminal provides a connection for bonding to equipment enclosure.

WATER SUPPLY CONNECTION

This equipment must be installed in accordance with all applicable federal, state, and/or local plumbing codes having jurisdiction.

NOTE: The Duke Flexbake 5™ Proof and Bake Oven must be supplied with water from a Reverse Osmosis (RO) System.

The water inlet utilizes 1/4" (6.35mm), OD plastic tubing. Install the tubing in a manner to ensure there are no kinks, strains, or tight bends. Leave sufficient length to allow unit movement for service and cleaning.

The tubing should be cut square and be free of any deformations at the connection points. All burrs and sharp edges should be removed for proper connection.

Insert the tubing through the compression fitting with the threads pointing towards the end of the tubing.

Push the tubing into the fitting as far as it will go and tighten the nut with a 9/16" (12.7mm), wrench. Do not over-tighten the nut. If leaks occur, further tighten the fitting until the leakage stops.

DRAIN TUBING CONNECTIONS

Packaged and shipped inside the oven is a drain tubing kit. Locate this tubing assembly and install as shown in the Figures below.

1. Push the two 1/2"ID x 5/8"OD tubes onto the 1/2" OD stainless steel drain tubes. The tubing assembly should be flush with the back of the oven and stand. Install a 5/8" snap-grip (ratchet) tube clamp on each tube and tighten with a pair of pliers to prevent any leaks.
2. Push the 1/4"ID x 3/8"OD tubing fully onto the open barb on the 'T' fitting.

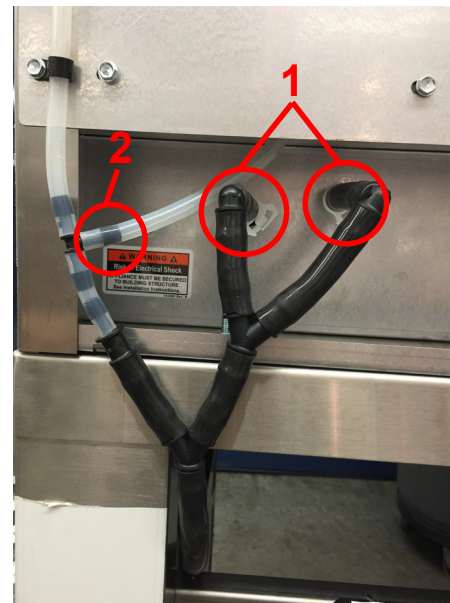

3. Push the 1/4"ID x 3/8"OD tubing onto the 1/4"OD drain tube on the upper vent box. Install a 3/8" snap-grip (ratchet) tube clamp on the tube and tighten with a pair of pliers to prevent any leaks.

4. Install the 2 loop clamps onto the 1/4"ID x 3/8"OD tubing and secure it with the existing screws.

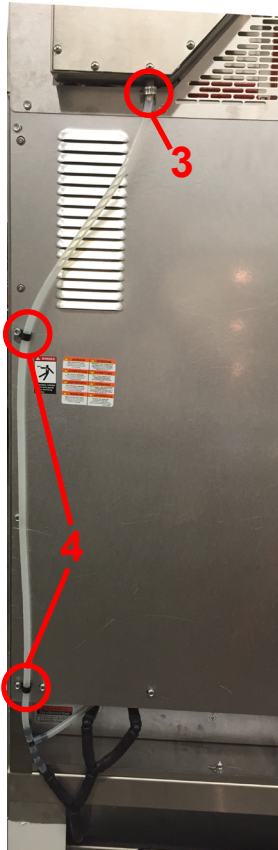

5. Route the loose end of the 1/2"ID x 5/8"OD tube over the top horizontal brace on the back of the stand and toward the front of the unit. From the front, route the tube into the locating hole on the top of the drain pail handle.

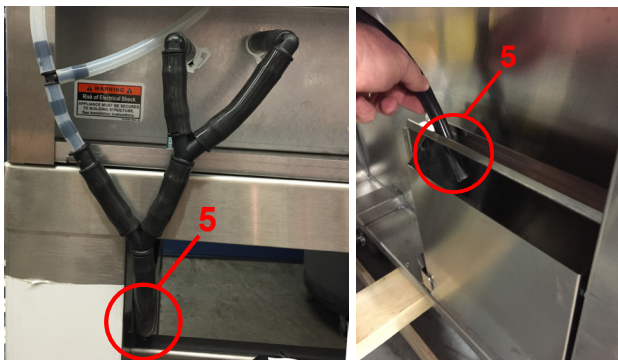

6. Inspect the tube routing and make sure there are no kinks in the tubing.

INSTALLATION

1. This unit can be converted to other mains supply configurations by Duke Manufacturing approved service personnel. Call Duke Service Department for action if electrical rating tag information is not compatible with the available mains supply.
2. This unit is supplied with the national and international specified water supply interconnection. Local regulation variances or additional requirements must be evaluated prior to installation. New water supply line interconnection must be used when installing this unit. Maximum / minimum supply pressure specification is 65PSI (450KPa) / 40PSI (275KPa) for all system plumbing components. See **INSTALLATION OF REVERSE OSMOSIS (RO) SYSTEM** section prior to water supply interconnect.



**HAZARDOUS VOLTAGE
RISK OF ELECTRIC SHOCK**

**DISCONNECT POWER TO SERVICE
COMPARTMENT**

**THIS RESTRAINING DEVICE
MUST ALWAYS BE CONNECTED
WHEN THE APPLIANCE IS IN
SERVICE. DISCONNECT ONLY FOR
SERVICING AND/OR CLEANING,
THEN RECONNECT WHEN THE
APPLIANCE HAS BEEN RETURNED
TO ITS NORMAL POSITION.**

- This appliance must be secured to building structure. A restraining device kit (#153586) provided with the unit limits the movement of the appliance without transmitting stress to the mains supply. Installation instructions are in the kit.

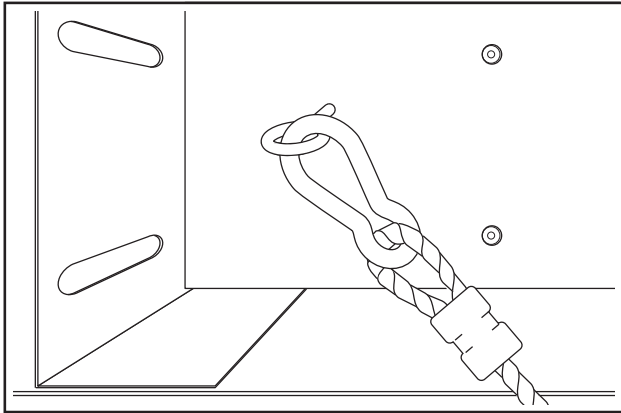

Figure: Restraining Device Kit (Part # 153586)

- IMPORTANT:** A minimum clearance of 6" (152mm) from the top of unit to the ceiling must be provided. Unit may be installed with minimal clearance on one side and rear of the cabinet.
- Check the swing of the door. The hinge side can be changed by referring to the **Reversing Oven Door Swing Direction section of this manual.**
- Check the door seal and make sure both doors close completely. If they do not close and seal properly, refer to the **Door Gasket Adjustment section of this manual.**
- Place the wire racks in the oven.

TECHNICAL DESCRIPTION AND APPLICATION NOTES FOR DUKE FLEXBAKE 5™ PROOF AND BAKE OVEN BACKFLOW PREVENTER SYSTEM

Check with your local authority having jurisdiction regarding approvals for connecting the Duke Flexbake 5™ Proof and Bake Oven to a potable water supply before making any plumbing connections. Plumbing code requirements vary, but European Union (CE) and other jurisdictions require a backflow prevention device that is factory-installed or available as a kit (P/N 600187). The backflow prevention device used on Duke Flexbake 5™ Proof and Bake Oven protects water supply systems by preventing the reverse flow of non-potable water into the potable domestic water system. The device consists of two independently acting check valves, internally force-loaded to a normally closed position and designed/constructed to operate under intermittent or continuous pressure conditions. The two main components of the Duke backflow preventer system are:

- Dual Check Valve type backflow preventer that conforms to ANSI/ASSE standard #1024 and is CSA standard B64.6 certified.
- Inlet water strainer equipped with 100-mesh screen and installed up stream of the backflow preventer. The screen is conveniently located below the backflow preventer, for easy access during cleaning/replacement.

Duke Manufacturing Co.

This equipment is intended to be connected to a potable water supply system under pressure and is to be installed with adequate backflow protection to comply with all applicable federal, state, and local codes.

This equipment must be supplied with water from a reverse osmosis system.

Water supply pressure for proper operation shall be:
Minimum 40 PSIG(275 KPa)
Maximum 65 PSIG(448 KPa)
measured at water line inlet to the equipment.

Patent(s) Pending

514773 A

PROOF AND BAKE OVEN START-UP



ELECTRICAL SHOCK HAZARD.

TASKS MUST BE PERFORMED BY A QUALIFIED SERVICE TECHNICIAN OR ELECTRICIAN.

1. Have a qualified service technician or electrician connect the Proof and Bake Oven to the power supply.
2. Turn power on to the unit with the power switch on the left side of the control panel. Boot Screen is displayed and automatically transitions to the Main Screen.
3. Turn the oven ON by touching the  button located at the lower left of the touch screen. The buttons and screen will turn to BLUE background. The Oven lights will turn on and start preheating.



Figure: Main Screen

4. Select a proof and bake recipe (Full Bake) and verify operation. The unit will automatically begin a conditioning cycle. Allow approximately 30 minutes for it to complete. When the conditioning cycle is complete, the display will change to the Oven Recipe Ready to Start screen.
5. Check the door seal and make sure the door closes completely.
6. If the unit does not power up correctly or if the door does not close and seal properly, call Duke for assistance.

AUDIBLE ALARMS

The Proof and Bake has various audible alarms.

1 chirp	Keystroke acknowledgement
3 triple chirps	Oven ready (up to temperature) notification
Continuous rapid beeps (continuous until cleared)	Oven door open alarm
2 long beeps (continuous until cleared)	Oven end of cycle
Triple beeps (continuous until cleared with door cycle or touching "Add Cheese NOW" message)	Add Cheese Time Alarm (2 min. prior to end of Proof Cycle)
3 triple chirps (repeating every minute until cleared)	Reminder: Start Bake
3 short beeps (with message persistent for 1 minute)	20 min. Alarm (prior to end of bake, alert to retard next load of bread)
3 short beeps	End of bake 2 min alarm

OPERATING INSTRUCTIONS

Oven/Proofer Start-Up

Turn ON the Duke Flexbake 5™ Main Power

Boot Screen



Automatically Transitions to Main Screen



Baking Main Screen

Recipe Name

Touch

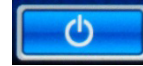

to turn on the Oven



Power Button Next Page

Touch Screen Definitions and Notifications

Main Tool Bar



Screen Sleep Button* Info Button

* Screen Sleep Button only available when Oven is off

Recipe Information Bar (Default - Off*)



* See Owner's Manual to turn On Recipe Temp Recipe Time

Door Open



With oven door open, CLOSE DOOR will flash in the Main Tool Bar.

Empty Drain Water Pan

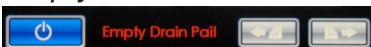

The Operator will be notified to empty drain pan each time the oven is turned on and after every 3rd Cool Down Cycle.

Start Bake Reminder

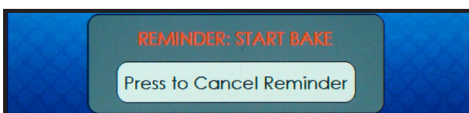

A start bake reminder message and alarm will alert the operator if the recipe timer has not been started 1 min. after bread has been loaded.

Add Cheese Alarm

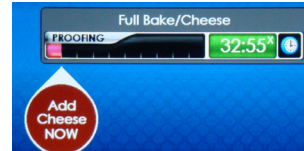

At 2:00 min remaining in the proof cycle, an alarm will beep to alert the operator to add cheese (ADD CHEESE NOW).

Note: Full Bake with Cheese or Half Bake with Cheese recipes only.

20 min. Alarm (Default - On*)



A bake complete in 20 min. message and alarm will alert the operator to retard the next load of bread for optimized baking throughput.

* See Owner's Manual to turn Off

Cancel Recipe

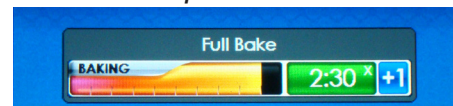

To cancel, press and hold countdown timer for 2-3 seconds.

Oven Cool Down



Select Cool Down, to rapidly cool the oven and condition it for another Proof and Bake Recipe. If Cool Down is not selected after a recipe, and a bread recipe is selected, the oven will automatically default to Cool Down.

DAILY PROOF AND BAKE OVEN START-UP

1. Turn power on to the unit with the power switch on the left side of the control panel. Boot Screen is displayed and automatically transitions to the Main Screen.
2. Turn the oven ON by touching the  button located at the lower left of the touch screen. The buttons and screen will turn to BLUE background. The Oven lights will turn on and start preheating.



Figure: Main Screen

3. Check to make sure that the oven fan is running.
4. Open the oven door; the oven fan should stop.
5. Close the door; the fan should resume.
6. Select your desired recipe. If this is a proof and bake recipe, allow the oven to preheat and condition for at least 30 minutes. An audible alarm will sound (3 short chirps) when the oven reaches the ready state. Your Duke Flexbake 5™ Proof and Bake Oven is now ready to operate.

If there are any problems refer to the Trouble Shooting section of this manual.

OVEN OPERATING INSTRUCTIONS

1. Turn the oven ON by touching the  button. The oven lights will turn on and the Oven will start preheating.

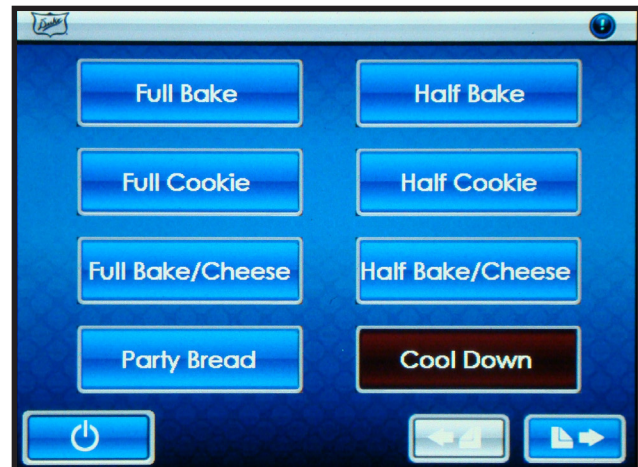

Figure: Oven Main Screen

- Select your desired RECIPE button. If a bake only recipe (i.e. Cookies) is selected, the Oven will continue to preheat. If a proof and bake recipe (i.e. Full Bake) is selected, the Oven will automatically begin a conditioning cycle. Allow approximately 30 minutes for the oven to preheat and condition.

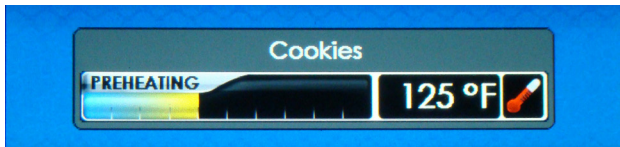

Figure: Oven Recipe Preheat Screen
(if under temp. setpoint for bake only recipe;
i.e. Cookies):



Figure: Recipe Conditioning Screen
(if oven is not conditioned for proof and
bake recipe; i.e. Full Bake):

- Once the preheat or conditioning cycle is complete, the display will change to the Oven Recipe Ready to Start screen. An audible alarm will sound (3 triple chirps) when the oven reaches the ready state.

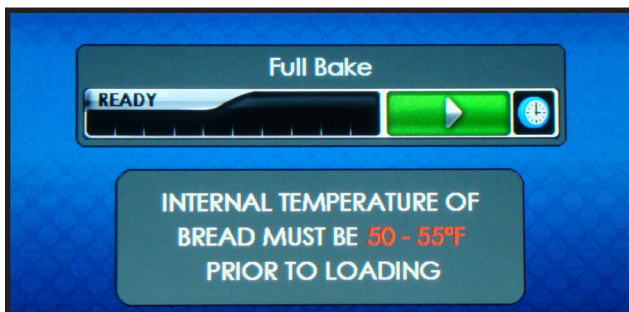

Figure: Oven Recipe Ready to Start

- Load the oven with dough and touch the start timer button. The remaining time will be displayed in the button area and the progress bar will change to visually show elapsed and remaining bake time.

NOTE: You can cancel an active timer with press and hold for 2 to 3 seconds on the count down timer.

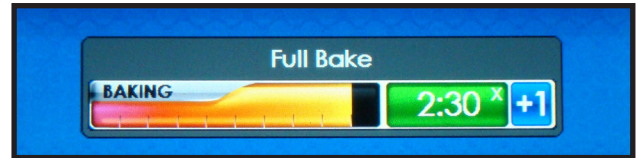

Figure: Oven Count Down Timer

- If a bake with cheese recipe was selected, at 2:00 minutes remaining in the proof cycle an alarm will beep (triple beeps) to alert the operator to add cheese. Add Cheese Now will be displayed. Touch the Add Cheese Now message or open the door to cancel the alarm.

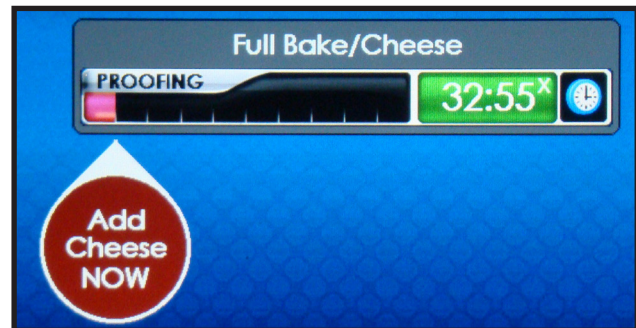

Figure: Cheese Time Alarm

- At 20 min. remaining in the bake, a bake complete in 20 min. message and alarm will alert the operator to retard the next load of bread for optimized baking throughput.



Figure: Retard Next Load Alarm

- When the bake is complete, an alarm will beep to alert the operator. Touch the Timer **0:00 x** or open the oven door to cancel the alarm.

NOTE: At 2:00 minutes remaining in the bake, an alarm will beep to alert the operator.

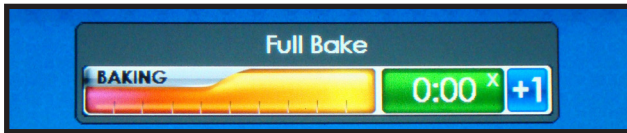



Figure: Oven Bake Complete Alarm

- You can add 1 minute to baking time by touching the **+1** button adjacent to the count down timer. This can be done at any time during the bake or at the end of a baking cycle. You must add time in 1 minute increments.
- Adjust the time, if necessary, depending on type of dough and desired results.
- If the next bake is a Proof and Bake recipe, select the CoolDown cycle to rapidly cool the oven.
- Once the CoolDown cycle is completed, select the desired recipe (i.e. **FULL BAKE** ) to condition the oven for the bake.
- When the oven is ready, the Oven Recipe Ready to start screen will be displayed.

BAKING TIPS

- Always select the oven recipe and allow preheat time prior to loading product. Only load when the Oven Recipe Ready to Start Timers screen is displayed. Load the oven with ten pans of dough and touch the start button.
- If the bread color is uneven, reduce temperature and extend bake time in recipe (see Programming Controls).
- If the bread is too dark, reduce the bake time in the recipe (see Programming Controls). If the bake time is reduced and the bread is still too dark, reduce the temperature by 15° F (10° C) and bake longer.
- When baking partial loads, start loading on the center shelf and work up and down from the center.
- Opening oven door allows heat to escape. Under normal conditions, quick loading and unloading will not be a problem. If door is left open too long, oven performance will be affected.

CARE AND CLEANING



OVEN INTERIOR AND RACKS ARE VERY HOT AND COOL SLOWLY.

ALLOW TO COOL BEFORE HANDLING.



ELECTRICAL SHOCK HAZARD:

DO NOT WASH WITH WATER JET OR HOSE.



DO NOT USE OVEN CLEANERS, CAUSTIC CLEANERS, DEGREASERS, ACIDS, AMMONIA PRODUCTS, ABRASIVE CLEANERS, STEEL WOOL, OR ABRASIVE PADS CONTAINING IRON. THESE CAN DAMAGE THE STAINLESS STEEL, DOOR GASKETS, PLASTIC SURFACES AND SENSORS.

DAILY CLEANING INSTRUCTIONS

1. Pour a large cup of hot water through the cavity bottom drain to flush any bread crumbs or seasoning from drain line.
2. Empty drain water pan.
3. Clean Drip Tray with clean damp cloth.
4. Clean stainless steel exterior with stainless steel cleaner or polish, or with hot soapy water followed by a clean water rinse.
5. Clean oven doors with a glass cleaner.
6. Clean oven interiors with a damp cloth. If heavy soil areas exist clean with hot soapy water and follow with clean damp cloth.

WEEKLY CLEANING INSTRUCTIONS

1. The Cool-Touch door has two window panes. The inner window can be easily separated from the outer window for cleaning. This is achieved by unlatching two clips and rotating the inner window on its hinges. After cleaning, the inner window frame is easily clipped to the outer window by squeezing the two windows together. For additional detail refer to "Cool-Touch Door Information" section of this manual.
2. Inspect oven door gaskets for cuts, tears or any other damage. Refer to the section on "Door Adjustments and Gasket Maintenance" for directions.

MONTHLY CLEANING INSTRUCTIONS

1. Check door screws for tightness.
2. Check the door gasket seal on the oven for leaks. Refer to the section on "Door Adjustments and Gasket Maintenance" for directions.

DOOR ADJUSTMENTS & GASKET MAINTENANCE



REVERSING OVEN DOOR SWING DIRECTION

Note: Reversing oven door requires 2 people.

1. Open oven door. Using an assistant to support the door, remove the six hinge screws from the inner face of the door (FIG 1).
2. Remove the (2) hinge pins and separate the inner hinge brackets from the outer hinge brackets (FIG 2).

NOTE: Take care to not lose upper/lower bushings and sleeves.

3. Remove the six screws on the front of the oven to expose the hinge screw holes for the other swing direction

4. Remove the six screws that hold the hinge to the front of the oven. Move the hinges to the other side, reattach and assemble using the hinge pins (FIG 3).
5. Use the six screws to fill the unused hinge screw holes on the front of the oven.
6. Remove the latch strike plate and spacer from the front of the oven and move it to the other side. Use the screws from the other side to fill the screw holes that are no longer used (FIG 4).
7. Re-assemble the hinges using the hinge pins.
8. Using an assistant, hold the door in place and reattach door to hinges with six screws (FIG 5). Make sure the door is level with the oven body before the screws are tightened permanently (FIG 6).
9. Refer to the DOOR GASKET LEAK TEST section of this manual to verify the proper seal of the door gasket.

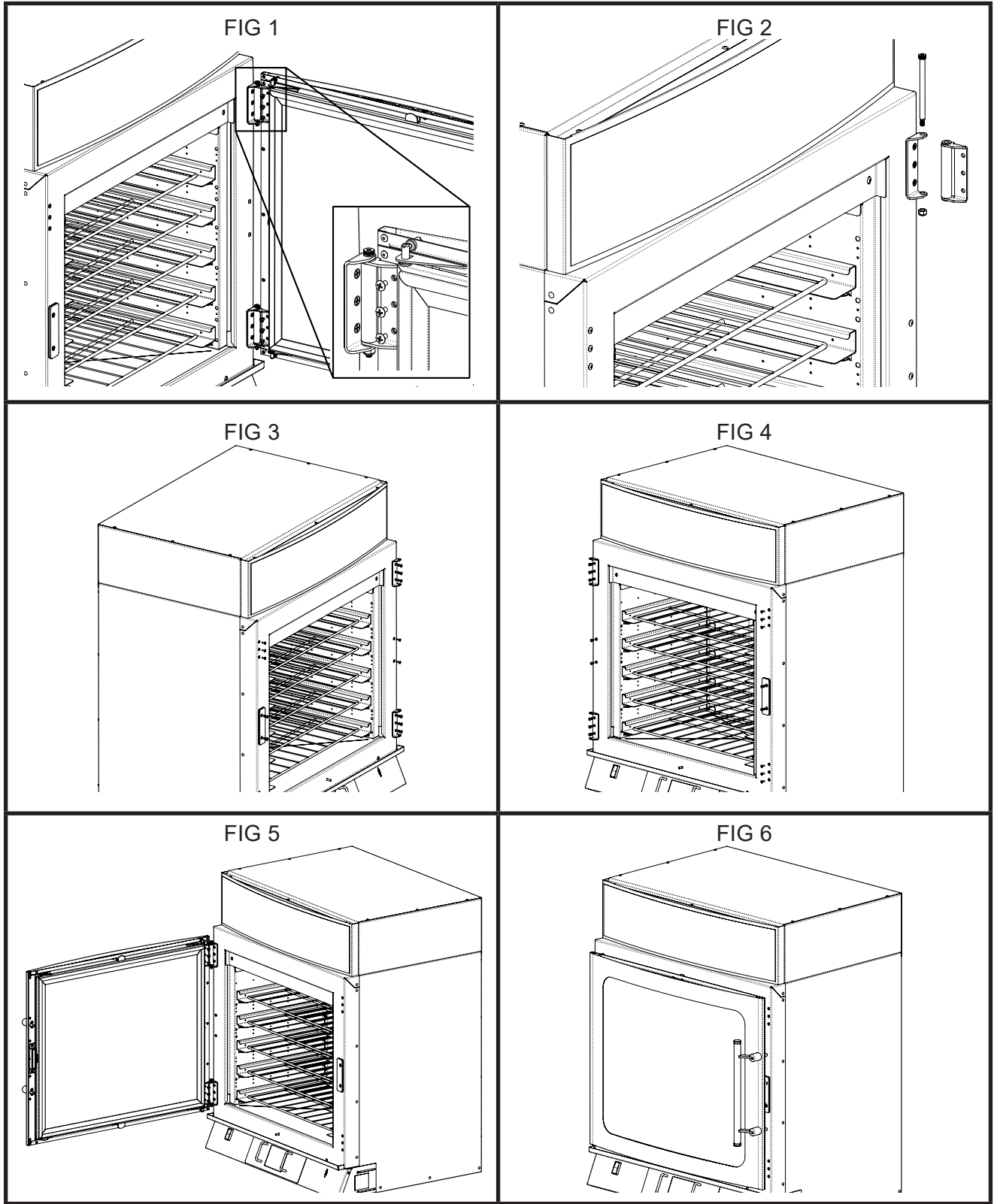

Figure: Illustration – Reversing Oven Door Direction

DOOR GASKET LEAK TEST:

The doors should be checked for leaks every three months. If the door gasket is damaged or compressed permanently, it should be replaced. Call Duke Manufacturing Co. at 800-735-3853 to order a new gasket.

To check the gasket for leaks, close the door with a currency bill between the gasket and front of the oven. Resistance should be felt when pulling the currency bill out with the door closed. Do this check in several places.

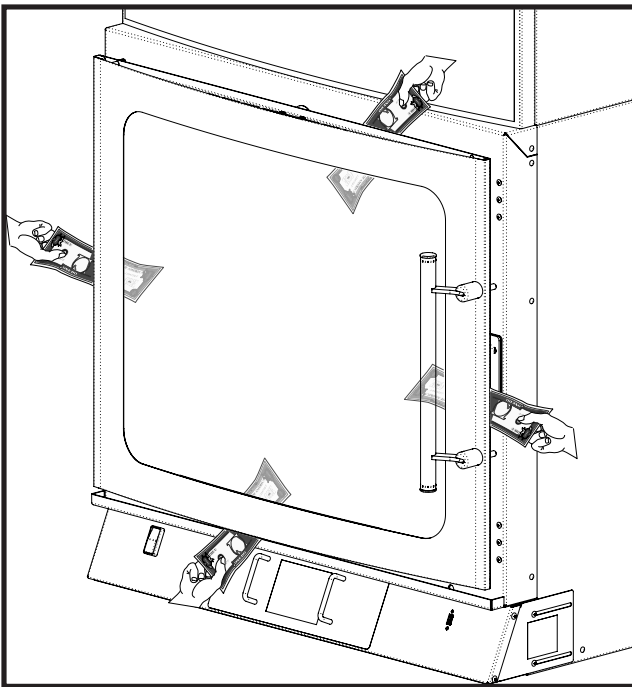

Figure: Gasket Check

GASKET REPLACEMENT:

1. Remove the old gasket by pulling it out of the groove in the door frame.

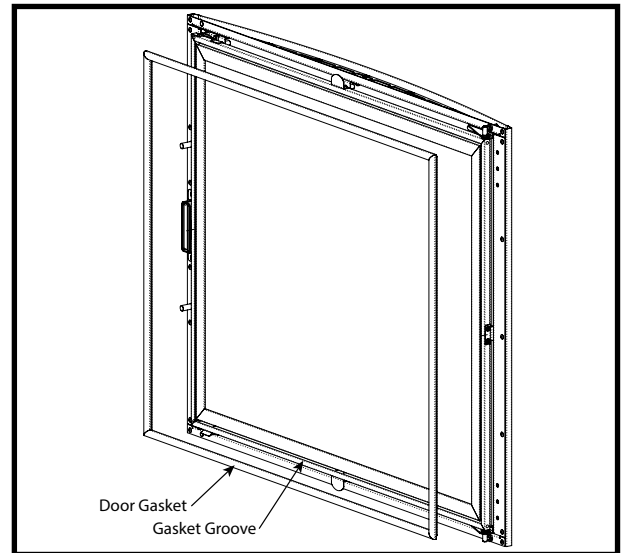

Figure: Door and Gasket

2. Clean the groove with a screwdriver or other flat-bladed tool to remove any dirt or gasket pieces.

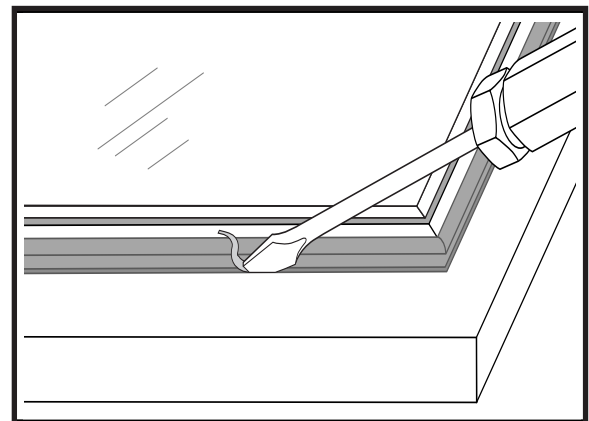

Figure: Cleaning Gasket Groove

3. Press the new gasket into the groove.
Make sure it is fully seated in the groove and flat against the door frame.

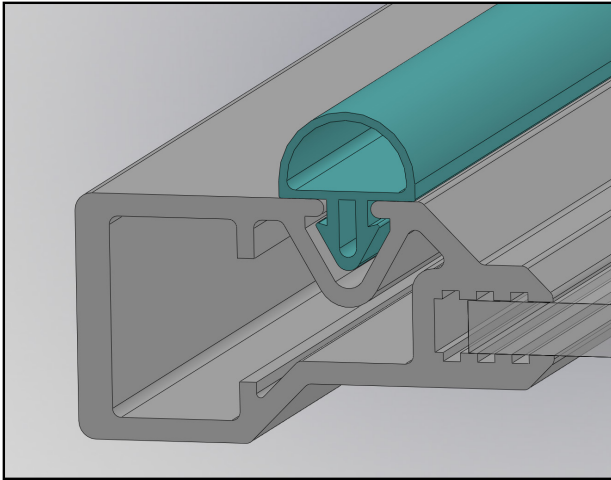

Figure: Properly Seated Gasket

4. Refer to DOOR GASKET LEAK TEST section of this manual to check the gasket for leaks. Also, check that the new gasket is not compressed too much, making the door hard to close. Call Duke Service for assistance if the gasket does not seal properly.

COOL-TOUCH DOOR INFORMATION AND CLEANING INSTRUCTIONS

The Cool-Touch door has two window panes. The inner window can be easily separated from the outer window for cleaning. This is achieved by unlatching two clips and rotating the inner window on its hinges. After cleaning, the inner window frame is easily clipped to the outer window by squeezing the two windows together.

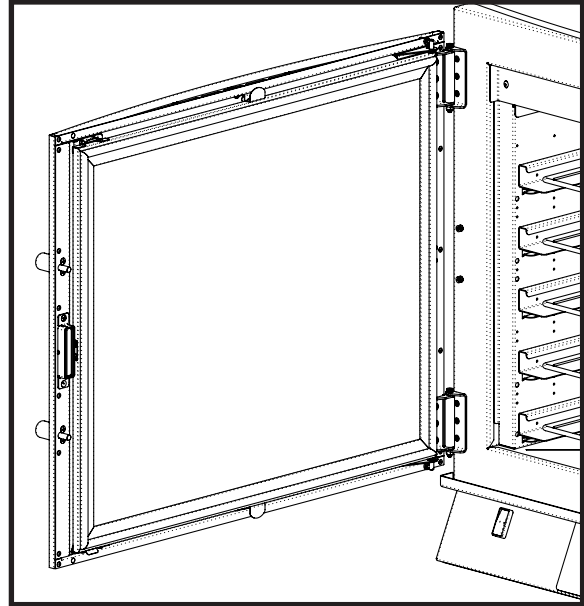

Figure: Cool-Touch Door inside view.

1. To open the windows for cleaning, unlatch the top clip.

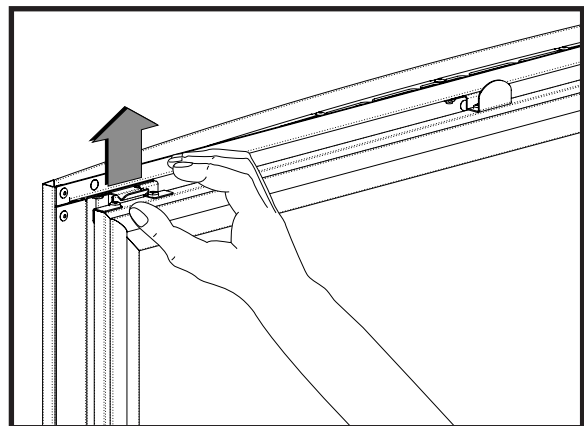

Figure: Unlatch Top clip

2. Unlatch the bottom clip.

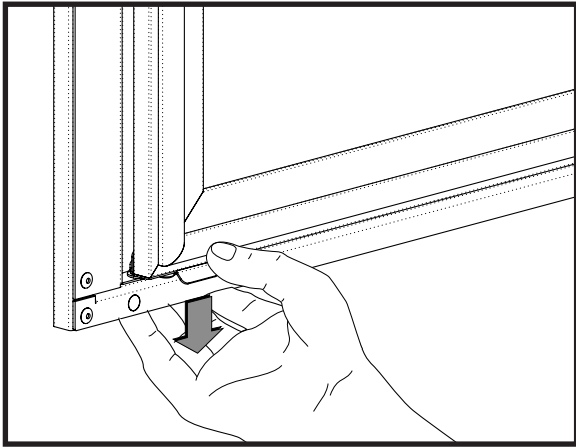

Figure: Unlatch Bottom Clip

3. Cool-Touch Door bottom easily swings open for cleaning.

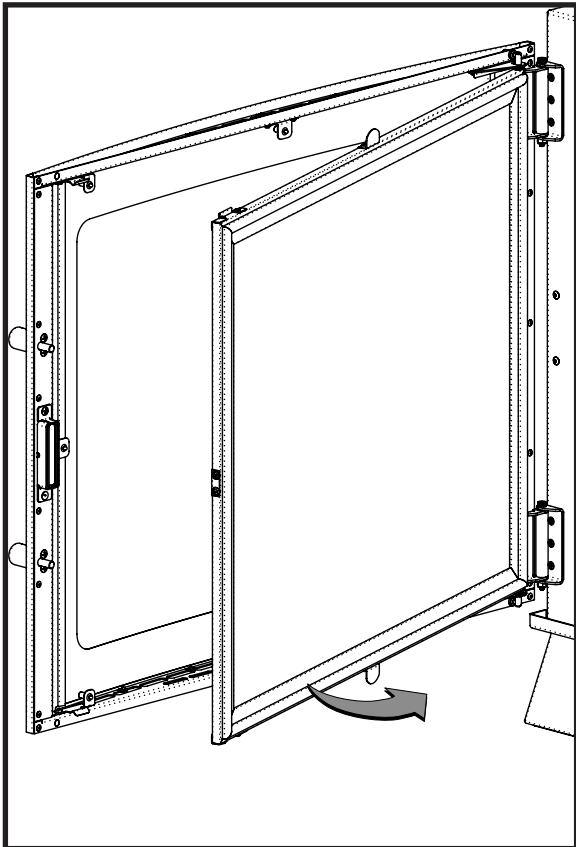

Figure: Door Swings Open for Cleaning

4. Cool-Touch inner door is easily clipped to the outer door by squeezing them together.

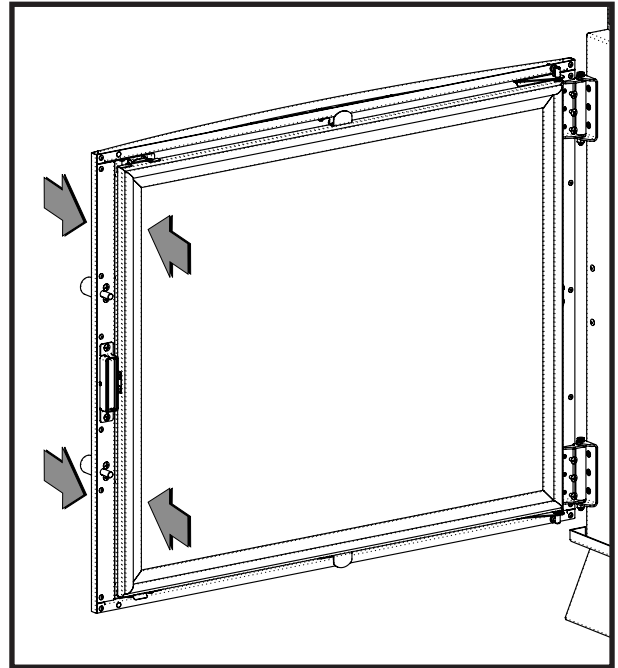

Figure: Door Clipped Together After Cleaning

LAMP BULB REPLACEMENT

BULB MOUNTING DETAILS

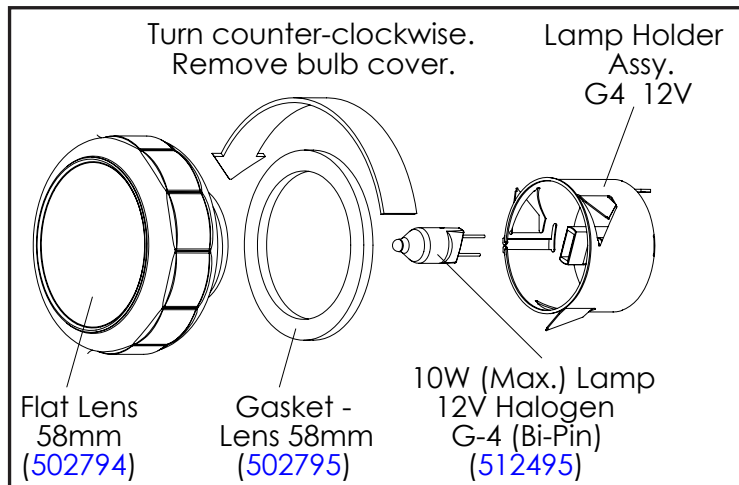

Figure: Halogen Lamp Assembly

CAUTION

DO NOT TOUCH LIGHT BULBS WITH BARE HANDS AS OIL/ FINGERPRINTS WILL SHORTEN THE LIFE OF THE BULB. USE A CLEAN GLOVE OR CLOTH TO HANDLE BULBS.

1. Turn the Proof and Bake Oven OFF and allow to cool.
2. Remove the light lens and gasket by turning it counter clockwise.
3. Remove the burned out bulb.
4. Using clean gloves or a cloth, install the new lamp bulb (Halogen Lamp G4, 12 Volts, 10 Watt Maximum) into the lamp holder.
5. Replace light lens and gasket ensuring it is fully seated and tightened or leaks will occur.

PROGRAMMING CONTROLS

To access the SPECIAL FUNCTIONS, touch  button on the Main Tool Bar.



Figure: Main Tool Bar

NOTE: There are 7 baking recipes and 1 CoolDown function single touch accessed from the main menu screen. There are a total of 21 recipes available on consecutive screen pages.



Figure: Special Functions Screen



Figure: Main Screen

RECIPE EDIT PROGRAMMING INSTRUCTIONS

NOTE: Your Duke FlexBake 5 oven has been factory configured with the standard recipes. Therefore, changes to these recipes should not be needed or should be minimal; such as a fine adjustment on time for browning.



1. Touch the  button and then enter pin code 5 6 7 8 and Touch the  button when prompted.
2. Touch the button for the recipe you want to edit (i.e. .



Figure: Stage Edit Selection Screen

Caution:

For proofing bread, Stage 1 temperatures should be 115°F or lower. Temperatures higher than 115°F do not require the oven to be cooled to start a recipe and automatic cool down cycle will not be initiated.

3. Touch the stage you want to edit (STAGE 1).

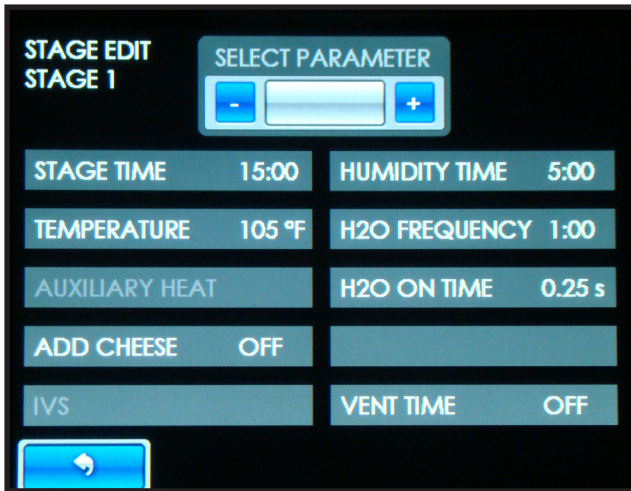





Figure: Stage Edit Selection Screen

• Touch the parameter you want to change (Stage Time, Temperature, etc.). Adjust the value using the  and  buttons and save your changes by pressing the  button.

- STAGE TIME – Time or duration of stage.
- TEMPERATURE – Temperature setpoint of stage.
- AUXILIARY HEAT – Percentage of auxiliary heater power. (Only on Bake Stages)
- ADD CHEESE – Toggles between OFF and ON. Turns ON the CHEESE ALARM.
- IVS – Toggles between OFF and ON. Turns ON the IVS hood (if equipped), mm:ss from the end of the stage.
- HUMIDITY TIME – Toggles between OFF and the length of time additional humidity is added to the beginning of the stage.
- H2O FREQUENCY – Frequency or time between calls for water during HUMIDITY TIME. (1:00 is strongly recommended.)
- H2O ON TIME – Time or duration of water introduced. (0.25s is strongly recommended.)
- VENT TIME – Toggles between OFF and the time or duration of powered vent cycle from the end of the stage.



Figure: Stage Edit Selection Screen

NOTE: To add a new recipe, touch a 'Blank' button. To add a stage to a new or existing recipe, touch the next consecutive 'Blank' button.



Figure: Blank Recipe Edit Selection Screen



Figure: Blank Stage Edit Selection Screen

4. To edit the recipe name, touch the  button for the EDIT RECIPE NAME screen.

NOTE: Typing will add letters/characters to the end of the text.

PRESS:











-  TO TOGGLE THE KEYBOARD BETWEEN THE UPPER/LOWER CASE CHARACTER SET.
- ,  AND  FOR THE NUMBER AND SYMBOL KEYBOARDS.
-  TO SPACE
-  TO CLEAR ALL TEXT
-  TO DELETE/BACKSPACE



Figure: Edit Recipe Name Screen

5. Touch the  button to save the changes and return to the RECIPE EDIT Screen. If no changes are required touch the  button to go back to the RECIPE EDIT Screen.

NOTE: You must touch the  button to save the changes you made.

6. When complete, touch the  button to go back to the previous screen. Press multiple times to return to the main screen.

USER (USER DOCUMENTS)

1. Touch the  button.
2. Touch the button for the information you want to view.
 - QUICK GUIDE – Overview of unit function
 - PROGRAMMING – Overview of secondary function
 - TROUBLESHOOT – Overview of troubleshooting steps
 - SYSTEM STATUS – Touching will display unit status
 - CARE/CLEANING – User safety, cleaning and door gasket check instructions
 - MAINTENANCE – Overview of maintenance items
 - SPECIFICATIONS – Overview of unit specifications
 - CONTACT US – Contact information
 - ABOUT – Software revision information

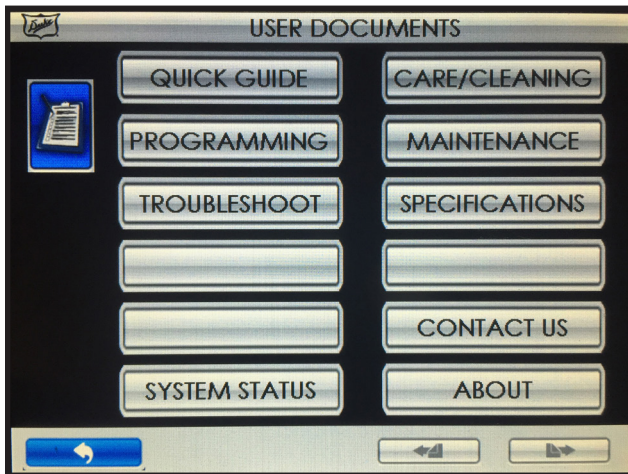







Figure: User Documents Screen

CONFIG (CONFIGURATIONS)

1. Touch the  button and then enter pin code 2 3 4 5 and Touch the  button when prompted.

2. Touch the button for the setting you want to edit.
 - DATE/TIME – Touching will display DATE/TIME edit screen. Touch the  or  button adjacent to the field you want to change. Touch the  button to save the changes.
 - LANGUAGE – Touching will display a list of included languages. Touch the preferred language button to select.
 - C/F SELECT – Touching will toggle between CENTIGRADE MODE ENABLED and FAHRENHEIT MODE ENABLED.
 - DEFAULT RECIPE – Touching will reload factory defaults.
 - SYSTEM STATUS – Touching will display unit status.
 - DRAIN PAIL MSG – Touching will toggle between message enabled and disabled.
 - 20 min. ALARM – Touching will toggle between 20 min. ALARM ENABLED and 20 min. ALARM DISABLED. A bake complete in 20 min. message and alarm will alert the operator to retard the next load of bread for optimized baking throughput.
 - STATUS BAR – Touching will toggle between STATUS BAR ENABLED and STATUS BAR DISABLED.

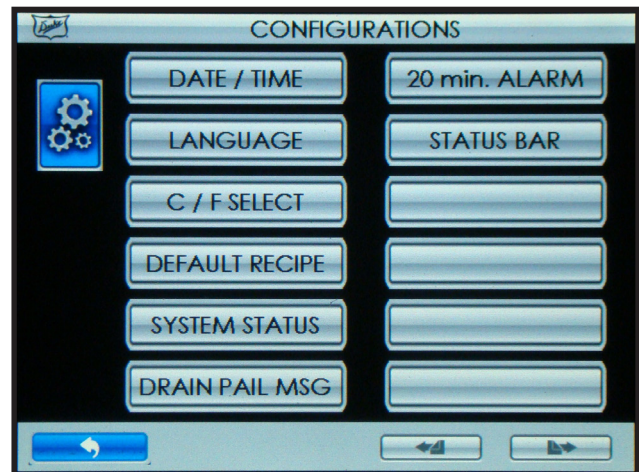

Figure: Configurations Screen

FILES (FILE MANAGEMENT)



1. Touch the  button and then enter pin code 3 4 5 6 and Touch the  button when prompted.
2. Insert USB drive with the file, until seated, into the USB Host Device.



Figure: USB Drive

- Select file operation from list and follow instruction on the display screen.
- OS LOAD – Update the control firmware.
- DOCS LOAD – Update the embedded User Manual and graphics files.
- EXPORT RECIPES – Saves Oven Recipes to a USB Drive
- IMPORT RECIPES – Loads Oven Recipes from a USB Drive
- DATA WRITE – Reserved for future use



Figure: File Management Screen

TOOLS (TOOLS)

- For factory and service use only

FACTORY (FACTORY SETTINGS)

- For factory and service use only

TROUBLESHOOTING

Problem	Yes	No
1. Touch Screen Control display is not ON a. Is the control panel power switch ON b. Is the main circuit breaker tripped?	Go to "b". Reset Circuit Breaker. Try oven again.	Turn on switch. Call Duke Service.
2. Oven lights not working. a. Is more than one light not working? b. Do lights work?	Replace inoperative light bulbs and recheck. Go to "b". Troubleshooting complete.	Replace inoperative light bulb and recheck. Go to "b". Call Duke Service.
3. Oven does not heat but Touch Screen Control and lights are ON. a. Is a recipe selected? b. Is the oven door securely closed c. Does the oven fan work?	Go to "b". Go to "c". Call Duke Service.	Select Recipe Close door securely. Call Duke Service.
4. Oven does not cool down in approx. 10 minutes with CoolDown selected. a. Does the oven fan work? b. Is the water supply to the oven on? c. Does oven cool properly?	Go to "b". Call Duke Service Troubleshooting complete.	Call Duke Service Turn water supply on. Go to "c". Call Duke Service.

A Manually reset high temperature safety limit is provided on the right side of the control section of the unit to protect the oven elements. The high limit will not trip under normal operating conditions. Should the oven high limit trip, push the RESET button. The high limit will reset with a "click" if an over temperature trip occurred. If condition persists, call Duke Service.

HIGH LIMIT PROTECTOR FOR OVEN ELEMENTS

LOADED ON RIGHT SIDE OF CONTROLS SECTION

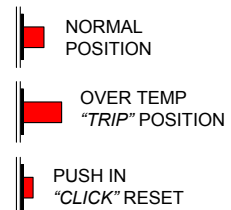



Duke Manufacturing Co.
2305 N. Broadway
St. Louis, MO 63102

Phone: 314-231-1130
Toll Free: 1-800-735-3853
Fax: 314-231-5074

www.dukemfg.com