

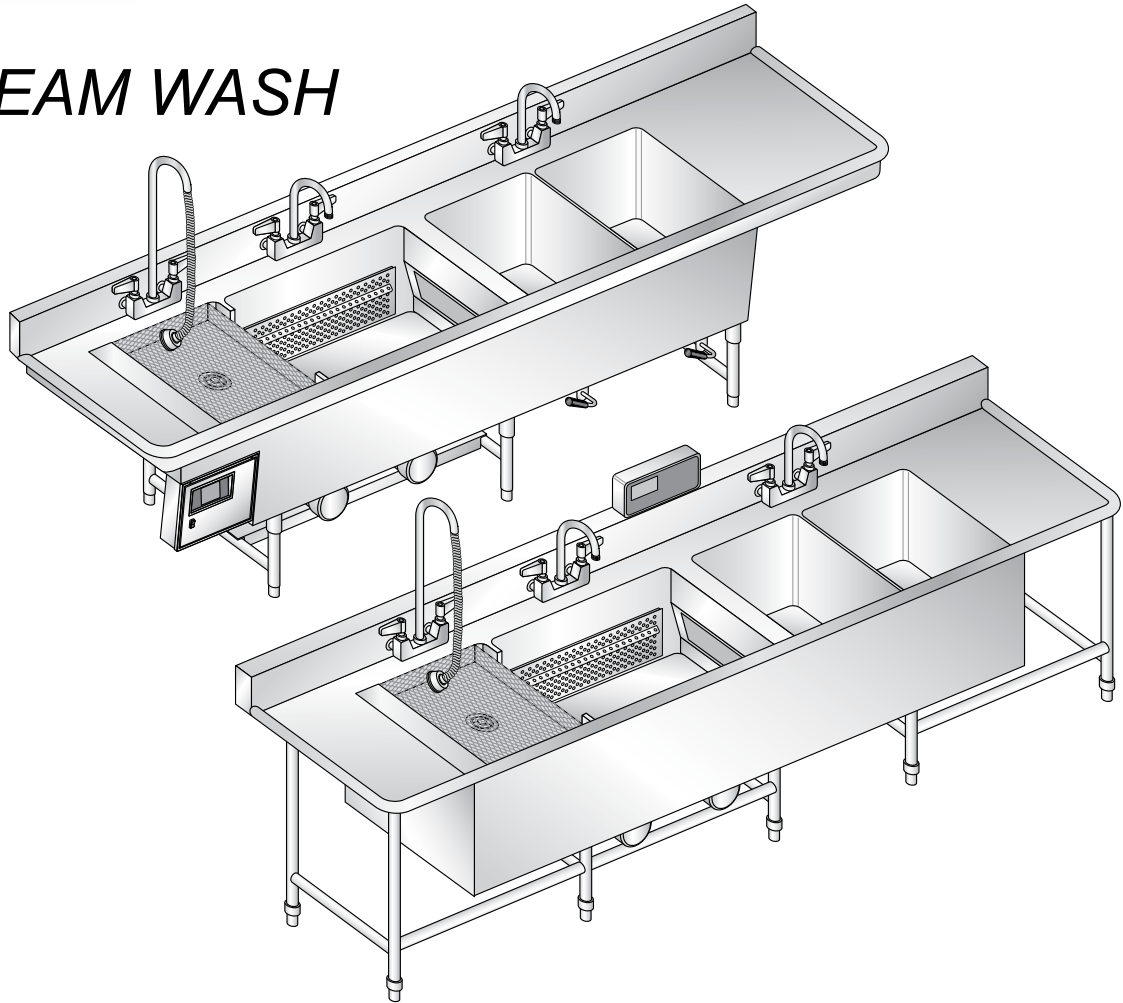

Your Solutions Partner

Illustrated Parts List

X-STREAM WASH



*This manual is Copyright © 2019 Duke Manufacturing Co. All rights reserved.
Reproduction without written permission is prohibited. Duke is a registered
trademark of the Duke Manufacturing Co.*

Duke Manufacturing Co.

**2305 N. Broadway
St. Louis, MO 63102
Phone: 314-231-1130
Toll Free: 1-800-735-3853
Fax: 314-231-5074**

www.dukemfg.com

How to Determine Manufacture Date from Duke Equipment Serial Numbers

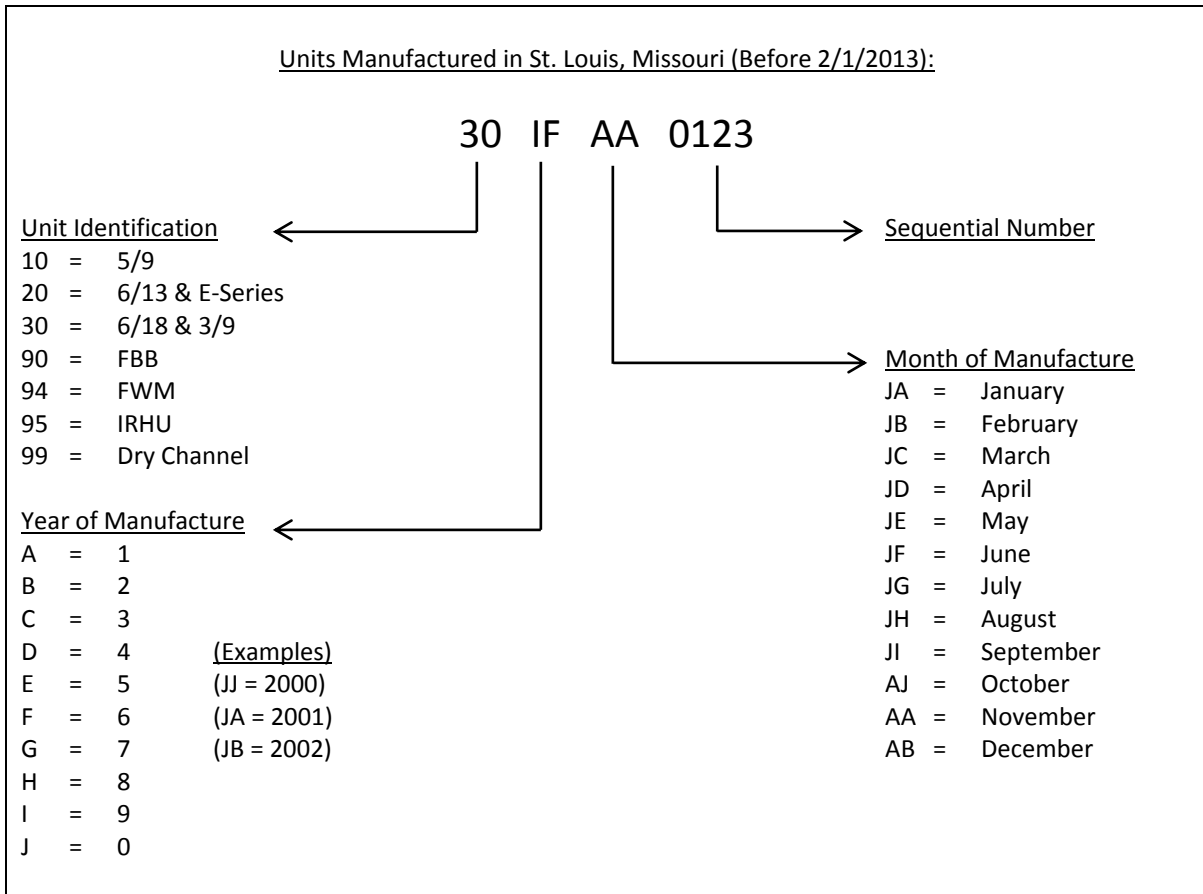
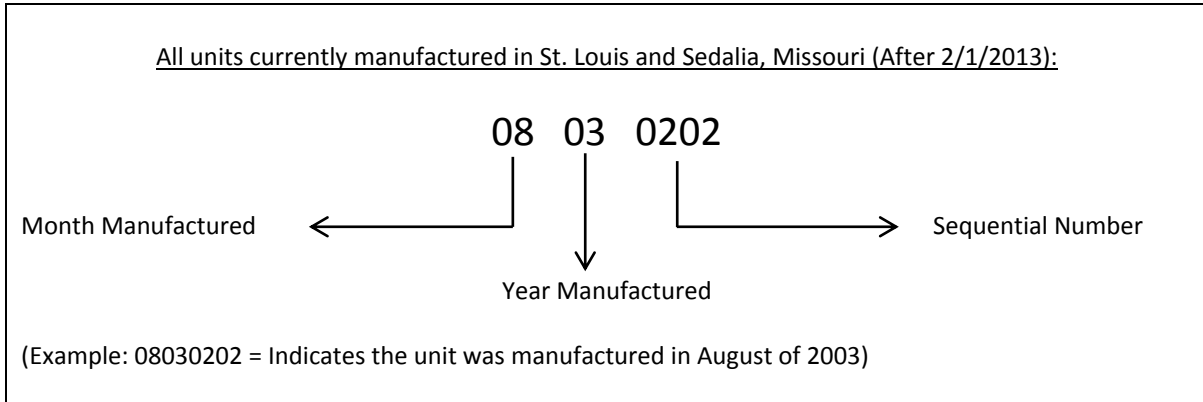

TABLE OF CONTENTS

K5000 TSC CONVERSIONS – 208-240V/3PH.....	4
Figure: PL-1 K5000 TSC Conversions – 208-240V/3Ph	4
Table: PL-1 K5000 TSC Conversions – 208-240V/3Ph.....	5
K5000 TSC CONVERSIONS – 440-480V/3PH.....	6
Figure: PL-2 K5000 TSC Conversions – 440-480V/3Ph	6
Table: PL-2 K5000 TSC Conversions – 440-480V/3Ph.....	7
WASH TANK COMPONENTS.....	8
Figure: PL-3 Wash Tank Components.....	8
Table: PL-3 Wash Tank Components	9
PUMP SHELF COMPONENTS.....	10
Figure: PL-4 Pump Shelf Components.....	10
Table: PL-4 Pump Shelf Components	11
SANITIZE TANK COMPONENTS	12
Figure: PL-5 Sanitize Tank Components.....	12
Table: PL-5 Sanitize Tank Components.....	13
FAUCETS.....	14
Figure: PL-6 Faucets.....	14
Table: PL-6 Faucets	14
ELECTRICAL SCHEMATICS	15
X-Stream K1000, 208-240V/60Hz/1Ph <i>(Units Prior to 12/1/2013)</i>	15
X-Stream K1000, 208-240V/60Hz/1Ph <i>(Units After 12/1/2013)</i>	16
X-Stream K1000, 208-240V/60Hz/3Ph <i>(Units Prior to 12/1/2013)</i>	17
X-Stream K1000, 208-240V/60Hz/3Ph <i>(Units After 12/1/2013)</i>	18
X-Stream K1000, 440-480V/60Hz/3Ph <i>(Units Prior to 12/1/2013)</i>	19
X-Stream K1000, 440-480V/60Hz/3Ph <i>(Units After 12/1/2013)</i>	20
X-Stream K5000, 208-240V/60Hz/3Ph <i>(Units Prior to 11/29/2017)</i>	21
X-Stream K5000, 440-480V/60Hz/3Ph	22
X-Stream K5000, 208-240V/60Hz/3Ph <i>(Units After 11/29/2017)</i>	23
X-Stream K5000, 208-240V/60Hz/3Ph, W/Sanitizer <i>(Units After 11/27/2017)</i>	24
X-Stream K5000, 440-480V/60Hz/3Ph <i>(Units After 3/2/2017)</i>	25
X-Stream K5000, 440-480V/60Hz/3Ph, W/Sanitizer <i>(Units After 11/29/2017)</i>	26
Retrofit, X-Stream K5000, 208-240V/60Hz/3Ph <i>(Units After 11/29/2017)</i>	27
Retrofit, X-Stream K5000, 440-480V/60Hz/3Ph <i>(Units After 11/29/2017)</i>	28

K5000 TSC CONVERSIONS – 208-240V/3PH

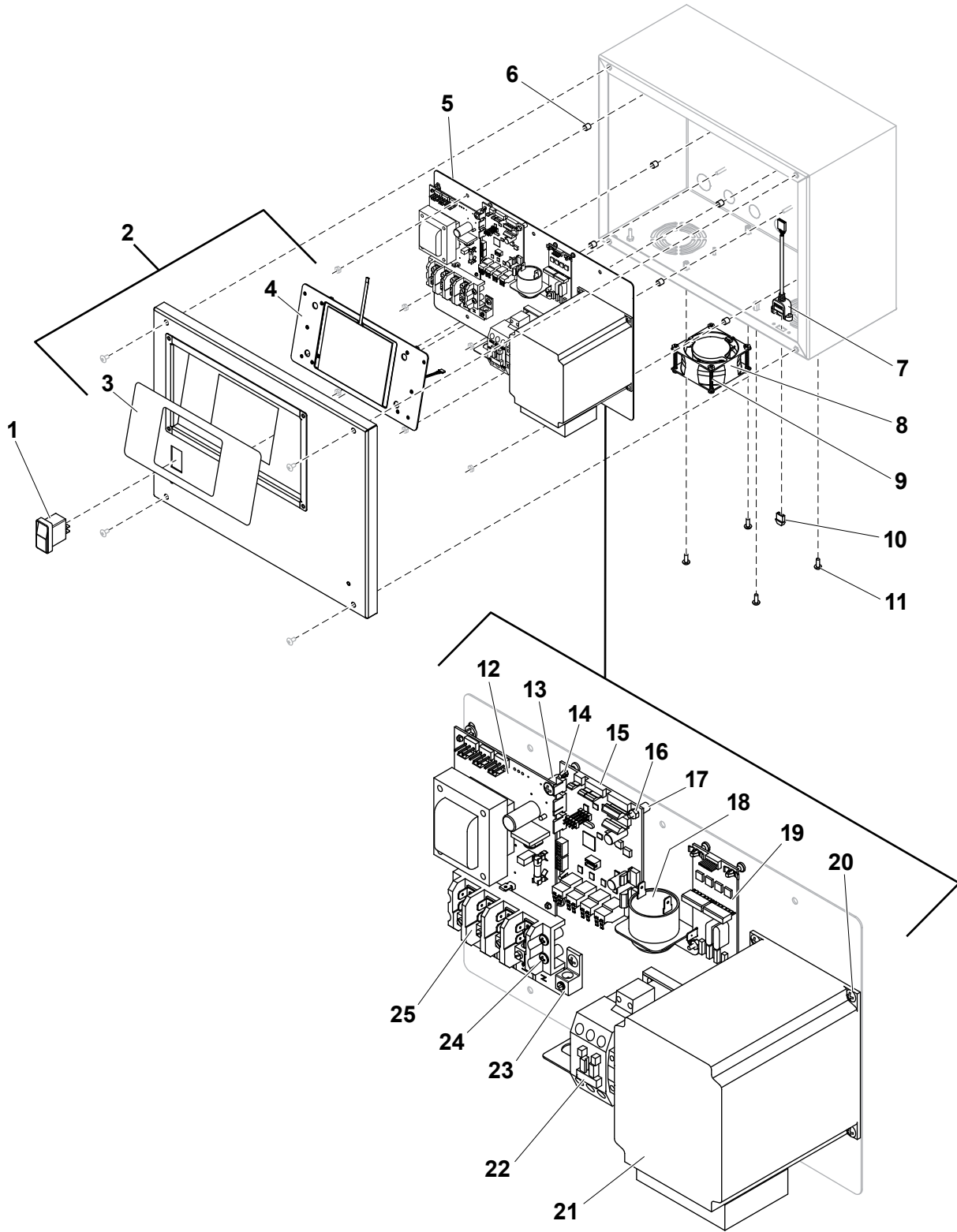

Figure: PL-1 K5000 TSC Conversions – 208-240V/3Ph

K5000 TSC CONVERSIONS – 208-240V/3PH

ITEM	PART NUMBER	DESCRIPTION	CONVERSION KITS	
			116924	116925 W/Heated Sani Sink
1	169629	SWITCH, SEALED CARLING	1	1
2	115468	ASSEMBLY, TOUCH SCREEN MOUNT, CONTROL K5000	1	1
3	116923	K5000 TOUCHSCREEN OVERLAY	1	1
4	ELC0017-6	ASSEMBLY, CONTROL MODULE, K-5000	1	1
5	116964	K5000, TSC, 208-240V/3PH, PANEL SUBASSY	1	
	116965	K5000, TSC, 208-240V/3PH, PANEL SUB-SSY, W/HTD SANI SINK		1
6	116946	SPACER 5/16" OD, 5/16" LENGTH	6	6
7	120007	CONNECTOR,USB PANEL MOUNT UPMA5-075M/CA USB-A NCR	1	1
8	159092	FAN, MUFFIN 29CFM 230V	1	1
9	116951	SCREW, 8-32 X 1-3/4 PPHMS SS	4	4
10	512550	CAP, USB	1	1
11	10280750	SCREW,10-24X1/2" TR PH SS MACHINE	8	8
12	120011	PCB,12V PWR 3A 208/230V	1	1
13	120158	SPACER, NUT .375"	2	2
14	166101	SUPPORT, LOCK-IN PC	6	6
15	176669	IO BOARD	1	1
16	223470	NUT, 4-40 NYLON LOCKNUT	2	2
17	166100	SPACER,TUBE NYLON .25 OD X .125 ID X .375 H	2	2
18	512766	BUZZER,ULTRA SOUND CONTINUOUS TONE	1	1
19	166114-1	TRIAC DRIVE PCB	1	1
20	213359	SCREW, 8-32X1/2 THRUSS PHILLI S/S	13	15
21	115680	ASSEMBLY, DRIVE MOTOR 3HP 208-240V W/PROGRAM	1	1
22	222790	CONTACTOR,TOR 240V 50/60HZ	1	2
23	983385	LUG, GROUND ILSKO TA-2	1	1
24	116940	SCREW, 8-32 X 3/4" LONG	4	4
25	120001	BLOCK, TERMINAL 4 POLE	1	1
NS	115143	GASKET, CONTROLLER DOOR EPDM	4-1/2 ft	4-1/2 ft
NS	115165	LANYARD, CONTROL PANEL	2	2
NS	116950	CIRCUIT BREAKER, K5000	3	3
NS	ELC0099	LOW V HARNESS	1	1
NS	ELC0101	DC PWR & CAN	1	1
NS	ELC0103	JUMPER LINE LOADS	1	1
NS	ELC0104	AC HARNESS	1	1
NS	ELC0107	AC HARNESS 2	1	
NS	ELC0109	VFD HARNESS	1	1
NS	ELC0114	VFD TO PUMP	1	1
NS	ELC0115	VFD W SANI HARN		1
NS	ELC0117	SANI CONTACTOR JUMPER LOADS		1
NS	ELC0154	GROUND HARNESS, K5000	1	1
NS	ELC0177	RETROFIT JUMPER	1	1

NS = Not Shown

Table: PL-1 K5000 TSC Conversions – 208-240V/3Ph

K5000 TSC CONVERSIONS – 440-480V/3PH

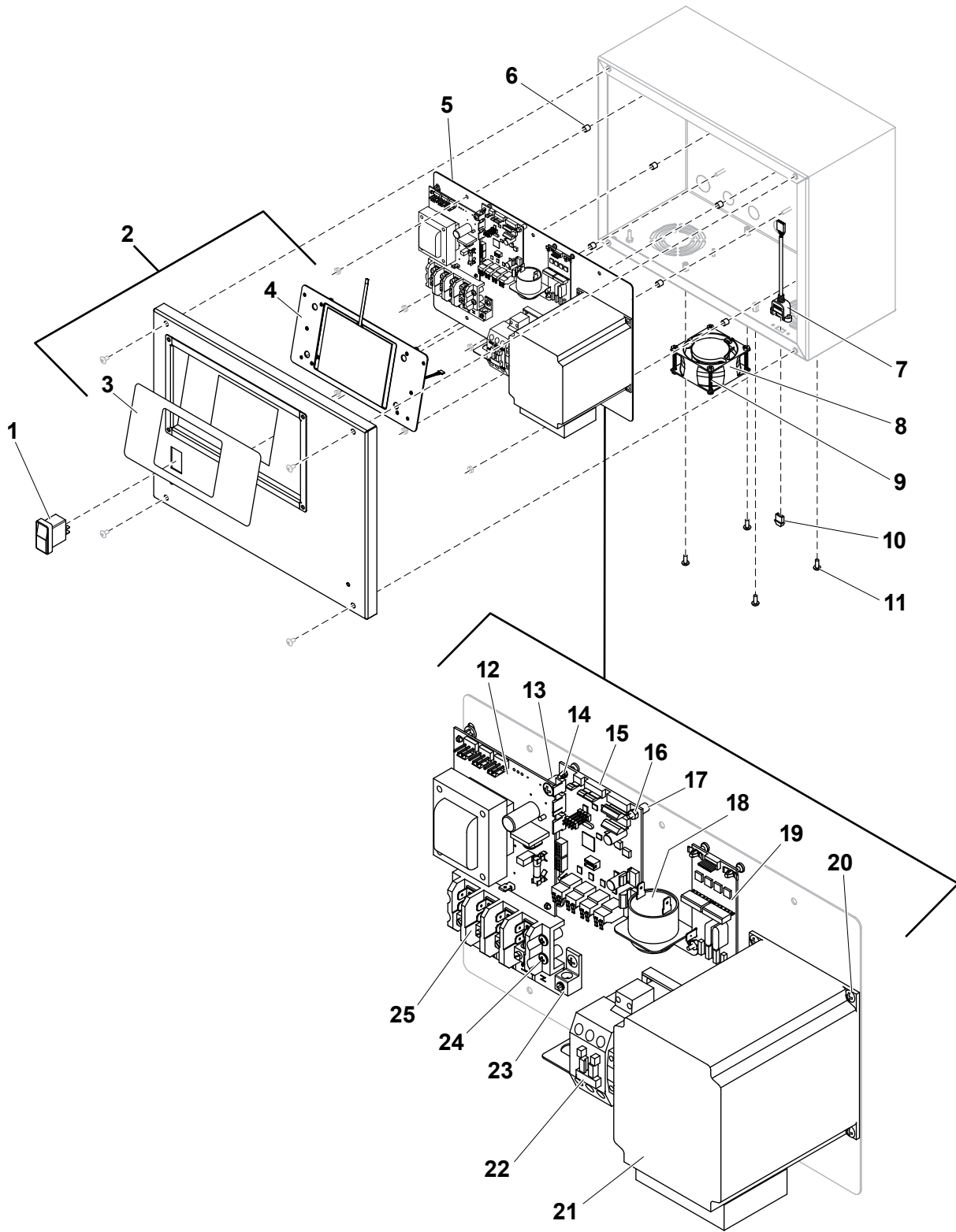

Figure: PL-2 K5000 TSC Conversions – 440-480V/3Ph

K5000 TSC CONVERSIONS – 440-480V/3PH

ITEM	PART NUMBER	DESCRIPTION	CONVERSION KITS	
			116926	116927 W/Heated Sani Sink
1	169629	SWITCH,SEALED CARLING	1	1
2	115468	ASSEMBLY, TOUCH SCREEN MOUNT, CONTROL K5000	1	1
3	116923	K5000 TOUCHSCREEN OVERLAY	1	1
4	ELC0017-6	ASSEMBLY, CONTROL MODULE, K-5000	1	1
5	116966	K5000, TSC, 440-480V/3PH, PANEL SUBASSY	1	
	116967	K5000, TSC, 440-480V/3PH, PANEL SUBASSY, W/HTD SANI SINK		1
6	116946	SPACER 5/16" OD, 5/16" LENGTH, FOR NUMBER 10 SCREW	6	6
7	120007	CONNECTOR,USB PANEL MOUNT UPMA5-075M/CA USB-A NCR	1	1
8	159092	FAN,MUFFIN 29CFM 230V	1	1
9	116951	SCREW, 8-32 X 1-3/4 PPHMS SS	4	4
10	512550	CAP, USB	1	1
11	10280750	SCREW,10-24X1/2"TR PH SS MACHINE	8	8
12	120011	PCB,12V PWR 3A 208/230V	1	1
13	120158	SPACER,NUT .375" * (SUBWAY OVEN)	2	2
14	166101	SUPPORT,LOCK-IN PC	6	6
15	176669	IO BOARD, BROILER	1	1
16	223470	NUT, 4-40 NYLON LOCKNUT	2	2
17	166100	SPACER, TUBE NYLON .25 OD X .125 ID X 0.375 H	2	2
18	512766	BUZZER,ULTRA SOUND CONT T	1	1
19	166114-1	TRIAC DRIVE PCB	1	1
20	213359	SCREW, 8-32X1/2 THRUSS PHILLI S/S	13	15
21	115681	ASSEMBLY, DRIVE MOTOR.3HP 440-480V W/PROG.	1	1
22	222790	CONTACTOR,TOR 240V 50/60H	1	2
23	983385	LUG,GROUND ILSCO TA-2	1	1
24	116940	SCREW, 8-32 THREAD SIZE, 3/4" LONG	4	4
25	120001	BLOCK,TERMINAL 4 POLE	1	1
NS	115143	GASKET,CONTROLLER DOOR EPDM	4-1/2 ft	4-1/2 ft
NS	115165	LANYARD,CONTROL PANEL	2	2
NS	116950	CIRCUIT BREAKER, K5000	3	3
NS	ELC0099	LOW V HARNESS	1	1
NS	ELC0101	DC PWR & CAN	1	1
NS	ELC0102	480 VFD HARNESS	1	1
NS	ELC0103	JUMPER LINE LOADS	1	1
NS	ELC0107	AC HARNESS 2	1	
NS	ELC0114	VFD TO PUMP	1	1
NS	ELC0115	VFD W SANI HARN		1
NS	ELC0117	SANI CONTACTOR JMPR LOADS		1
NS	ELC0154	GROUND HARNESS, K5000	1	1
NS	ELC0163	480 AC HARNESS	1	1
NS	ELC0164	480 XFMR HARNESS	1	1
NS	WLC0179	480 RETROFIT JUMPER	1	1
NS	115032	TRANSFORMAER, 0.75 KVA	1	1

NS = Not Shown

Table: PL-2 K5000 TSC Conversions – 440-480V/3Ph

WASH TANK COMPONENTS

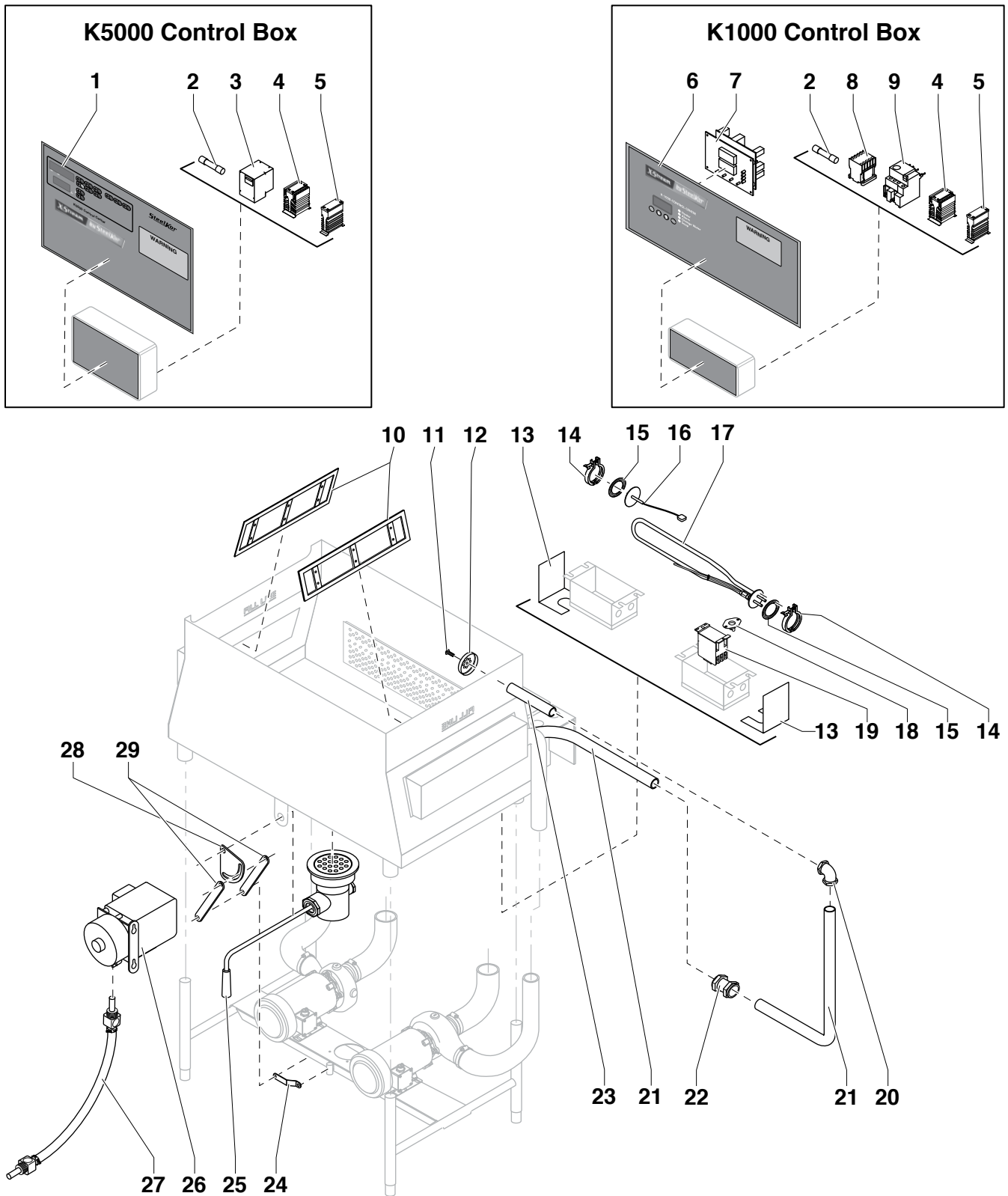

Figure: PL-3 Wash Tank Components

WASH TANK COMPONENTS

ITEM	PART NUMBER	DESCRIPTION	QTY.
1	115108	MYLAR, K5000	1
2	115060	FUSE (All Control boxes, but only in circuit for optional soap dispenser)	1
3	115029	INVERTER DRIVE (K5000)	1
4	115061	RELAY, SS, 40A (K1000/K5000 208/240, 5kw & 7.5kw Elements)	1
5	115062	RELAY, SS, 25A (K1000/K5000 208/240/480, 2.5kw Element)	1
Not Shown	116917	KIT, K5000 to K1000 RETROFIT, 208-240V	1
Not Shown	600478	KIT, K5000 to K1000 RETROFIT, 440-480V, 3 PHASE	1
6	116698	ASY, K1000 PANEL BOX COVER & MYLAR (<i>Duke</i>)	1
	116697	ASY, K1000 PANEL BOX COVER & MYLAR (<i>Champion</i>)	1
7	115418	ASSEMBLY, CONTROL, K1000 with PROGRAM	1
8	115063	CONTACTOR (K1000)	1
9	115676	RELAY, OVERLOAD (K1000)	1
10	115142	GASKET, DISCHARGE, 40 DURO	2
11	115173	SCREW, OVERFLOW HEAD	1
12	115172	COVER, OVERFLOW HEAD	1
13	115568	COVER, JUNCTION BOX	2
14	115118	WINGNUT CLAMP, QUICK CLAMP	2
15	115119	GASKET, QUICK CLAMP, 1-1/2"	2
16	115088	ASY, THERMOCOUPLE, WATER TEMP	1
17	115734	HEATER ASSEMBLY, 240V 2500W	1
	115735	HEATER ASSEMBLY, 240V 5000W	1
	115736	HEATER ASSEMBLY, 240V 7000W	1
	115737	HEATER ASSEMBLY, 480V 2500W	1
	115738	HEATER ASSEMBLY, 480V 5000W	1
	115739	HEATER ASSEMBLY, 480V 7000W	1
18	115144	THERMOSTAT, 250°F SETPOINT	1
19	153156	CONTACTOR, 50AMP POLE	1
20	115154	COUPLING, 1-1/4" 90DEG., DBL. SLIP JOINT	1
21	115129	TUBE, OVERFLOW	2
22	115153	COUPLING, 1-1/4" STRAIGHT. DBL.SLIP JOINT	1
23	115557	TUBE, OVERFLOW, 1-1/4"X6.5"	1
24	115548	PUMP LINKAGE, SHORT BAR	1
25	115127	DRAIN, TWIST HANDLE LEVER	1
26	115022	PUMP, CHEMICAL, 230V, 60HZ	1
27	115180	TUBE ASSEMBLY, CHEMICAL PUMP	1
28	115546	PUMP LINKAGE PLATE, CAM	1
29	115547	PUMP LINKAGE, LONG BAR	2

Table: PL-3 Wash Tank Components

PUMP SHELF COMPONENTS

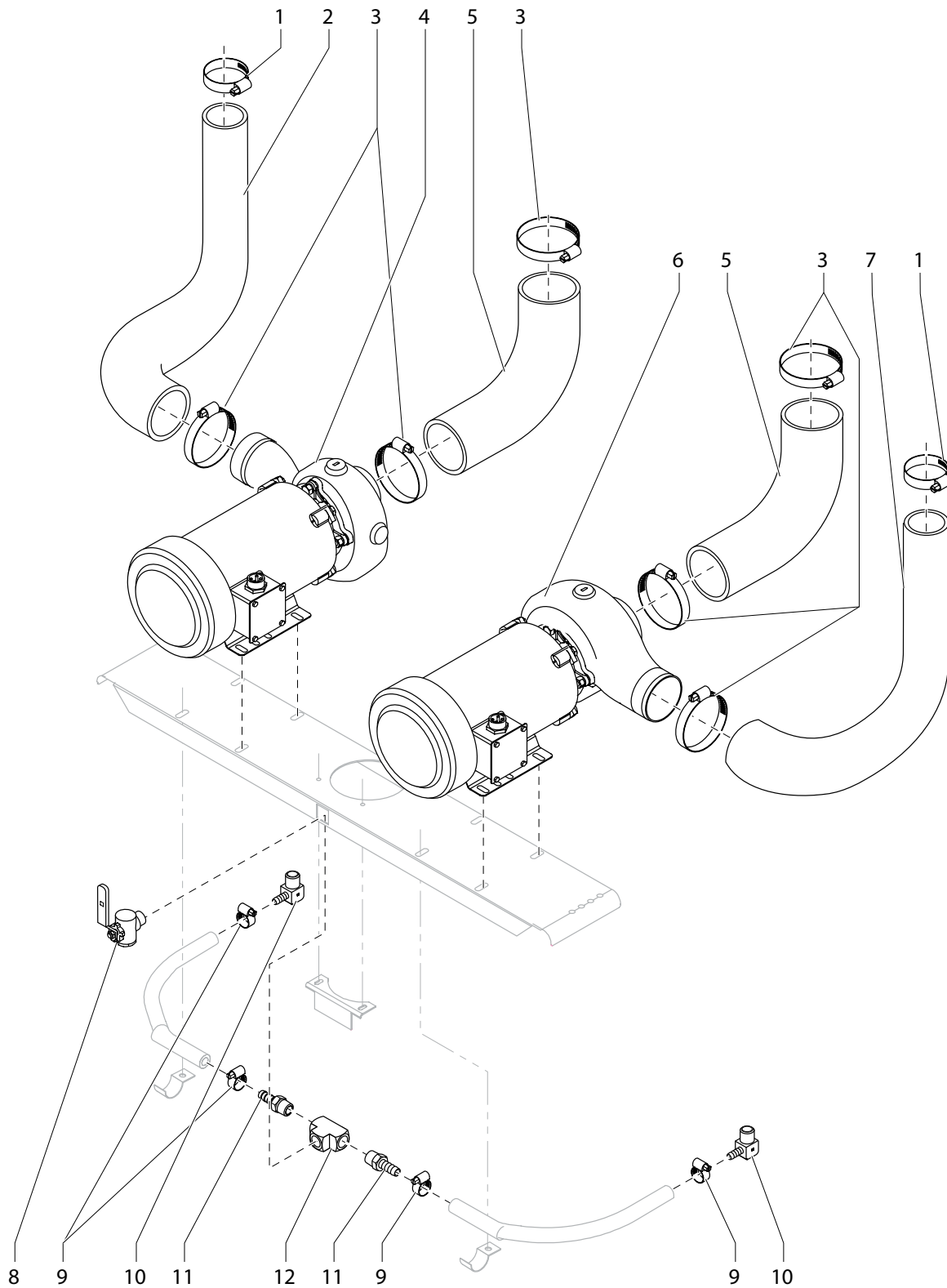

Figure: PL-4 Pump Shelf Components

PUMP SHELF COMPONENTS

ITEM	PART NUMBER	DESCRIPTION	QTY.
1	115140	CLAMP, HOSE, 2"-3", STAINLESS	2
2	115114	HOSE, RUBBER, LEFT HAND	1
3	115141	CLAMP, HOSE, 3"-4", STAINLESS	6
4	115674	PUMP ASSEMBLY, 208-240V 3PH LH	1
5	115116	HOSE, RUBBER ELBOW	2
6	115672	PUMP ASSEMBLY, 208-240V 3PH RH	1
7	115115	HOSE, RUBBER, RIGHT HAND	1
8	115133	VALVE, BALL, 1/2" ELBOW, BRASS	1
9	115139	CLAMP, HOSE, 7/16"-1", STAINLESS	4
10	115135	ELBOW, 90DEG., 3/8" PIPE	2
11	115134	ADAPTER, 1/2" NPT PIPE X 1/2"	2
12	115160	TEE, 1/2" BRASS, 1" WIDE	1
Not shown	115701	PUMP ASSEMBLY, 440-480V 3PH LH	1
Not shown	115700	PUMP ASSEMBLY, 440-480V 3PH RH	1

Table: PL-4 Pump Shelf Components

SANITIZE TANK COMPONENTS

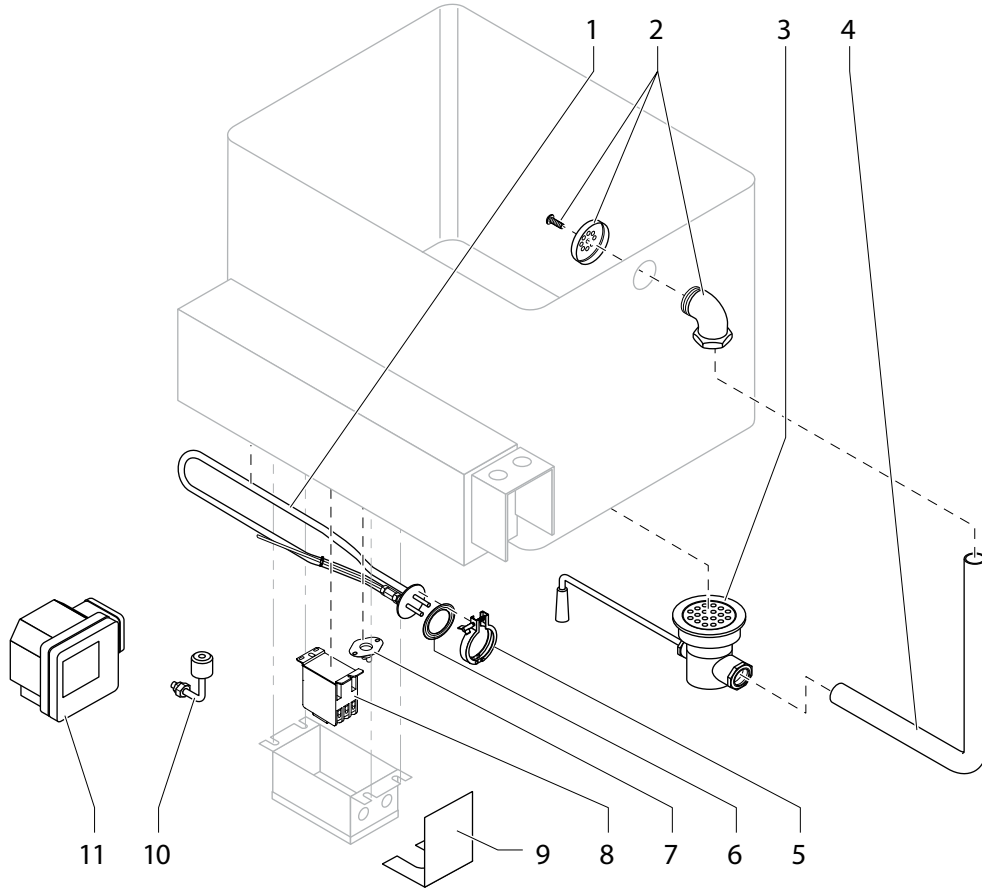

Figure: PL-5 Sanitize Tank Components

SANITIZE TANK COMPONENTS

ITEM	PART NUMBER	DESCRIPTION	QTY.
1	115734	HEATER ASSEMBLY, 240V 2500W	1
	115737	HEATER ASSEMBLY, 480V 2500W	
2	115156	OVERFLOW HEAD ASSEMBLY	1
3	115127	DRAIN, WASTE, TWIST HANDLE LEVER	1
4	115129	OVERFLOW TUBE	1
5	115118	WINGNUT CLAMP, QUICK CLAMP	1
6	115119	GASKET, QUICK CLAMP, 1-1/2"	1
7	115144	THERMOSTAT, 250°F SETPOINT	1
8	153156	CONTACTOR, 50AMP 3 POLE	1
9	115568	COVER, JUNCTION BOX	1
10	115037	SWITCH, FLOAT, 90°	1
11	115023	PUMP, CHEMICAL, ONE SHOT, SINGLE HEAD	1

Table: PL-5 Sanitize Tank Components



FAUCETS

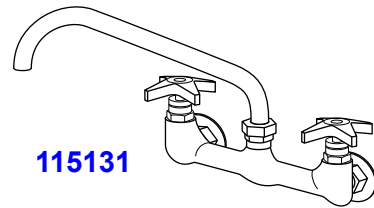
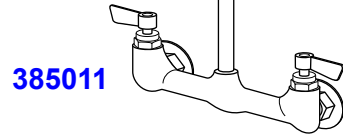
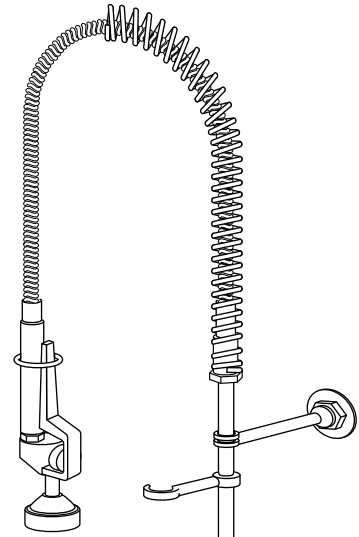
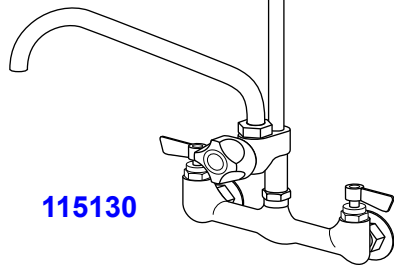
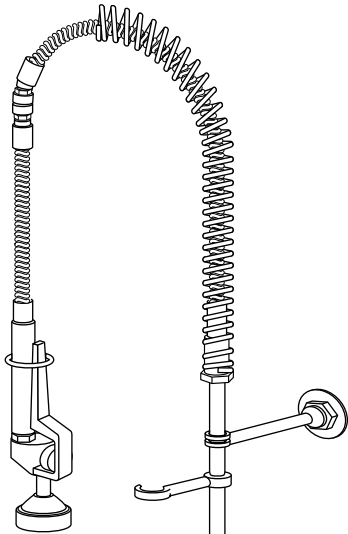
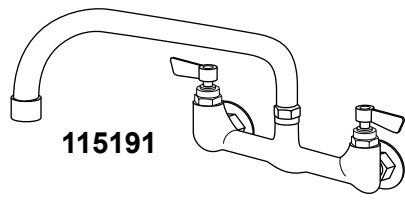
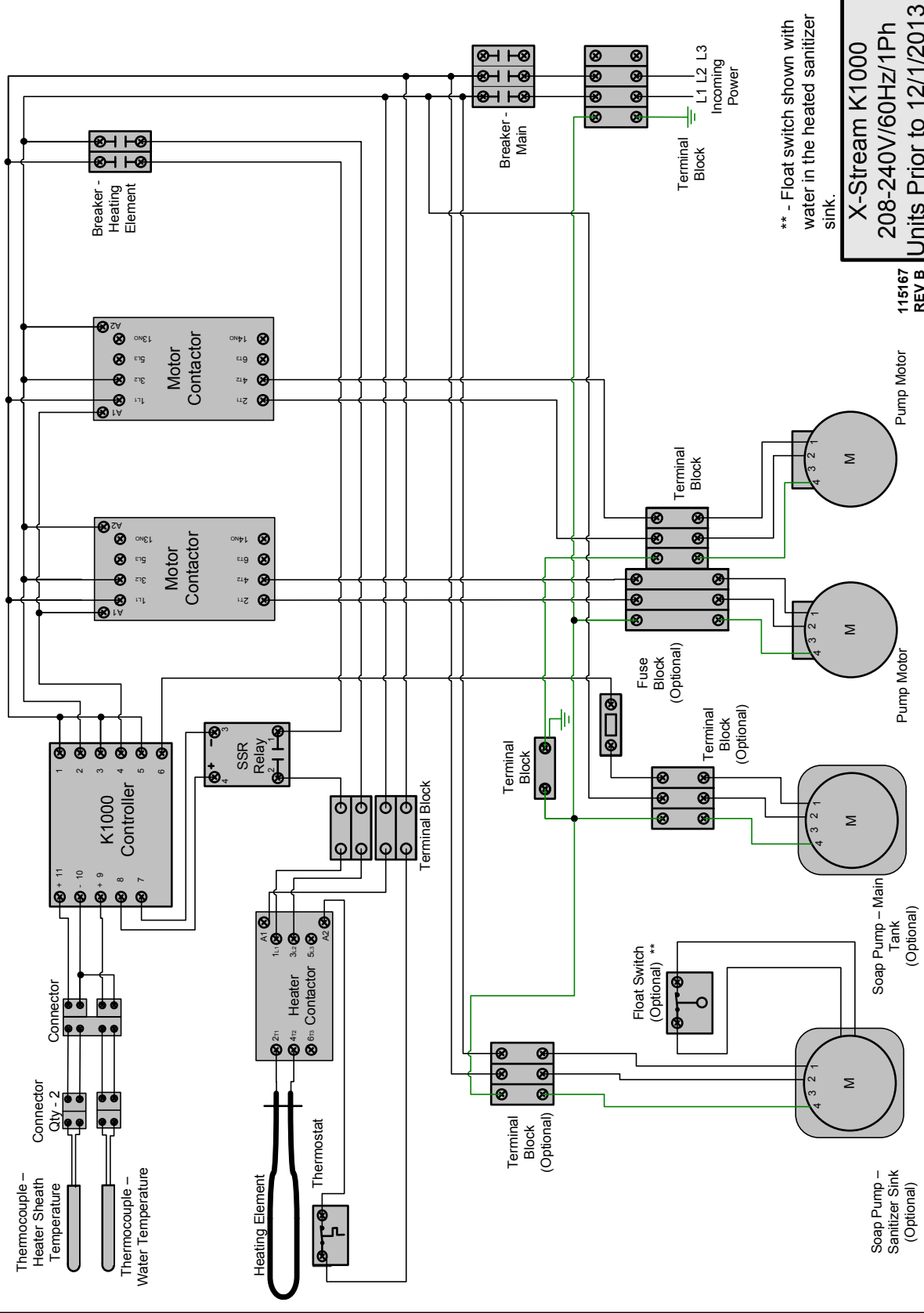

Figure: PL-6 Faucets

ITEM	PART NUMBER	DESCRIPTION	QTY.
1	115191	FAUCET, 1/2" INLET	1
2	385011	FAUCET, PRE-RINSE SPLASH, 1/2" INLET	1
3	115130	FAUCET, 3/4" INLET	1
4	115131	FAUCET, PRE-RINSE SPLASH, 3/4"	1

Table: PL-6 Faucets

FOR SUPPLY CONNECTIONS, USE WIRES RATED FOR AT LEAST 90°C (194°F). USE COPPER CONDUCTORS ONLY.



** - Float switch shown with water in the heated sanitizer sink.

**X-Stream K1000
208-240V/60Hz/1Ph
Units Prior to 12/1/2013**

115167
REV B

FOR SUPPLY CONNECTIONS, USE WIRES RATED FOR AT LEAST 90°C (194°F). USE COPPER CONDUCTORS ONLY.

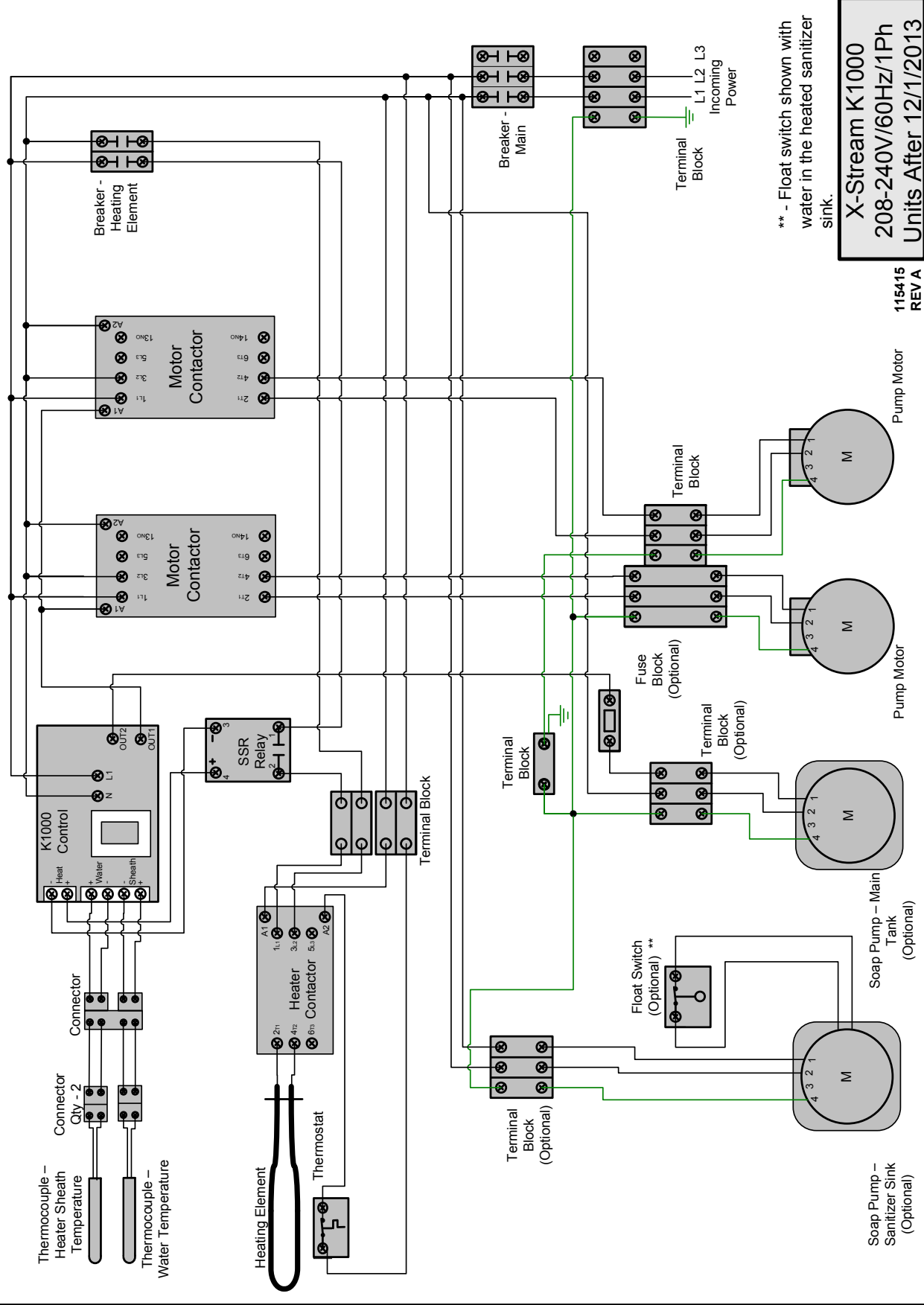

** - Float switch shown with water in the heated sanitizer sink.

**X-Stream K1000
208-240V/60Hz/1Ph
Units After 12/1/2013**

115415
REVA

FOR SUPPLY CONNECTIONS, USE WIRES RATED FOR AT LEAST 90°C (194°F). USE COPPER CONDUCTORS ONLY.

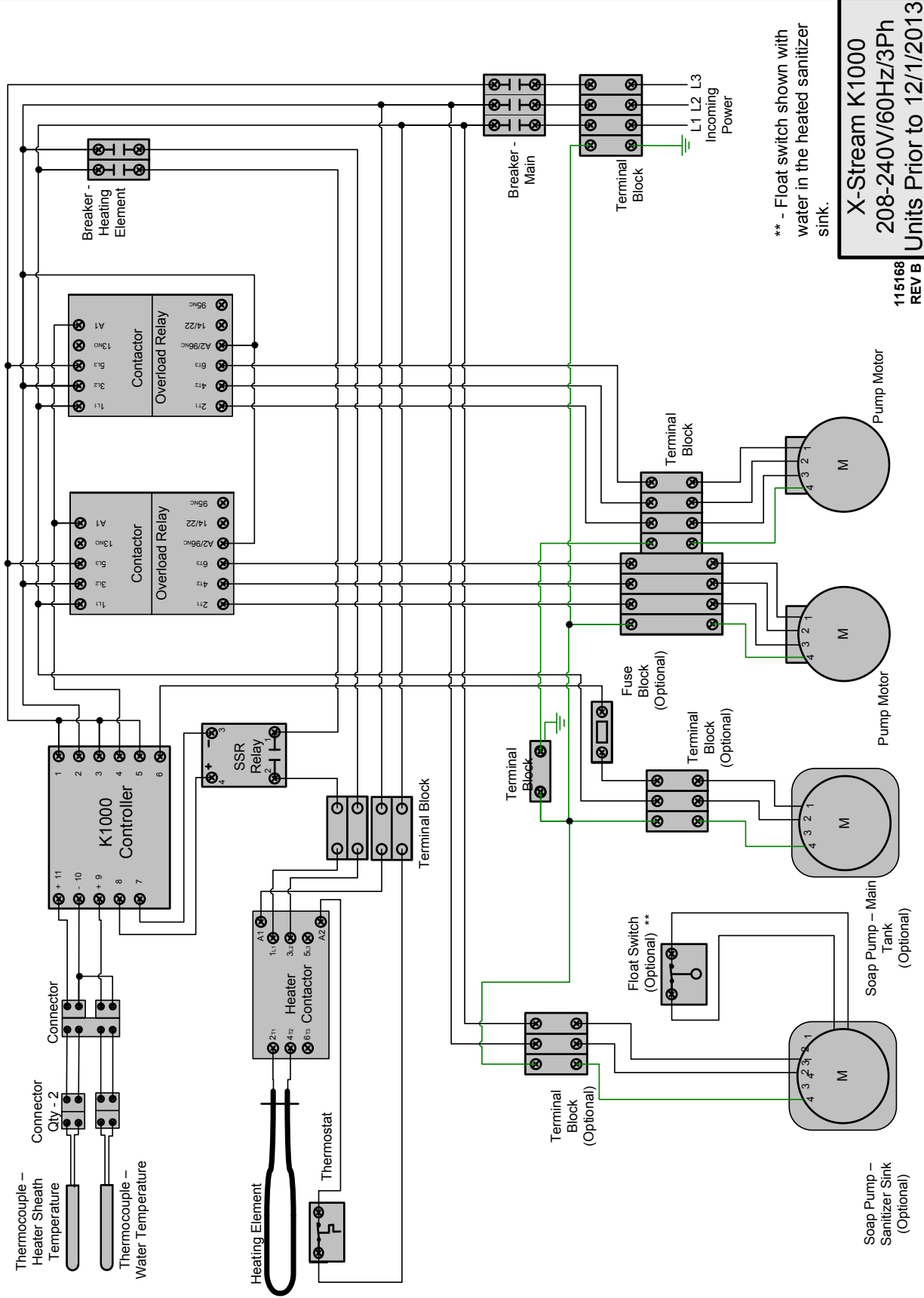

** - Float switch shown with water in the heated sanitizer sink.

X-Stream K1000
208-240V/60Hz/3Ph
Units Prior to 12/1/2013

115168
 REV B

FOR SUPPLY CONNECTIONS, USE WIRES RATED FOR AT LEAST 90°C (194°F). USE COPPER CONDUCTORS ONLY.

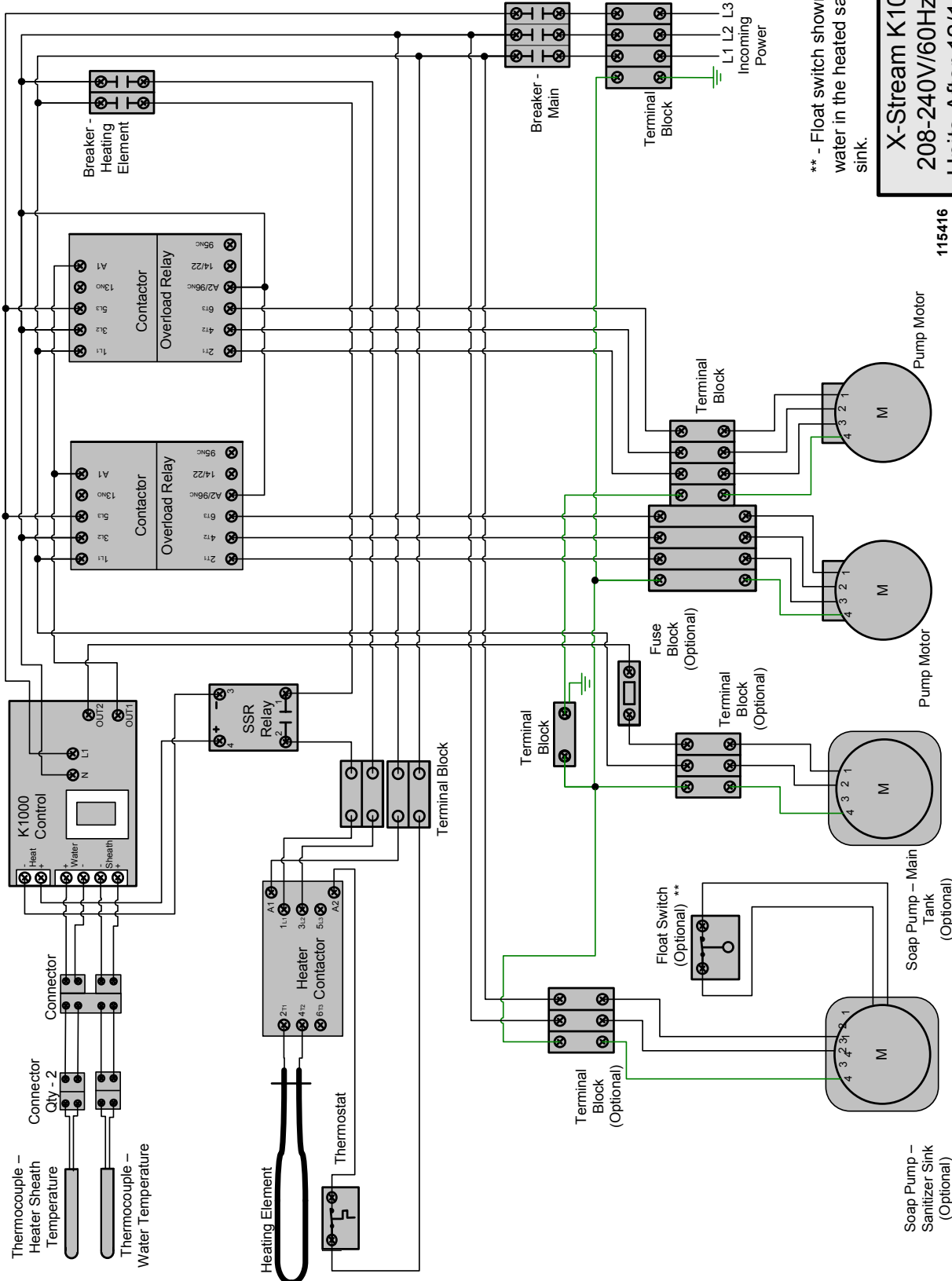

** - Float switch shown with water in the heated sanitizer sink.

**X-Stream K1000
208-240V/60Hz/3Ph
Units After 12/11/2013**

115416
REV A

FOR SUPPLY CONNECTIONS, USE WIRES RATED FOR AT LEAST 90°C (194°F). USE COPPER CONDUCTORS ONLY.

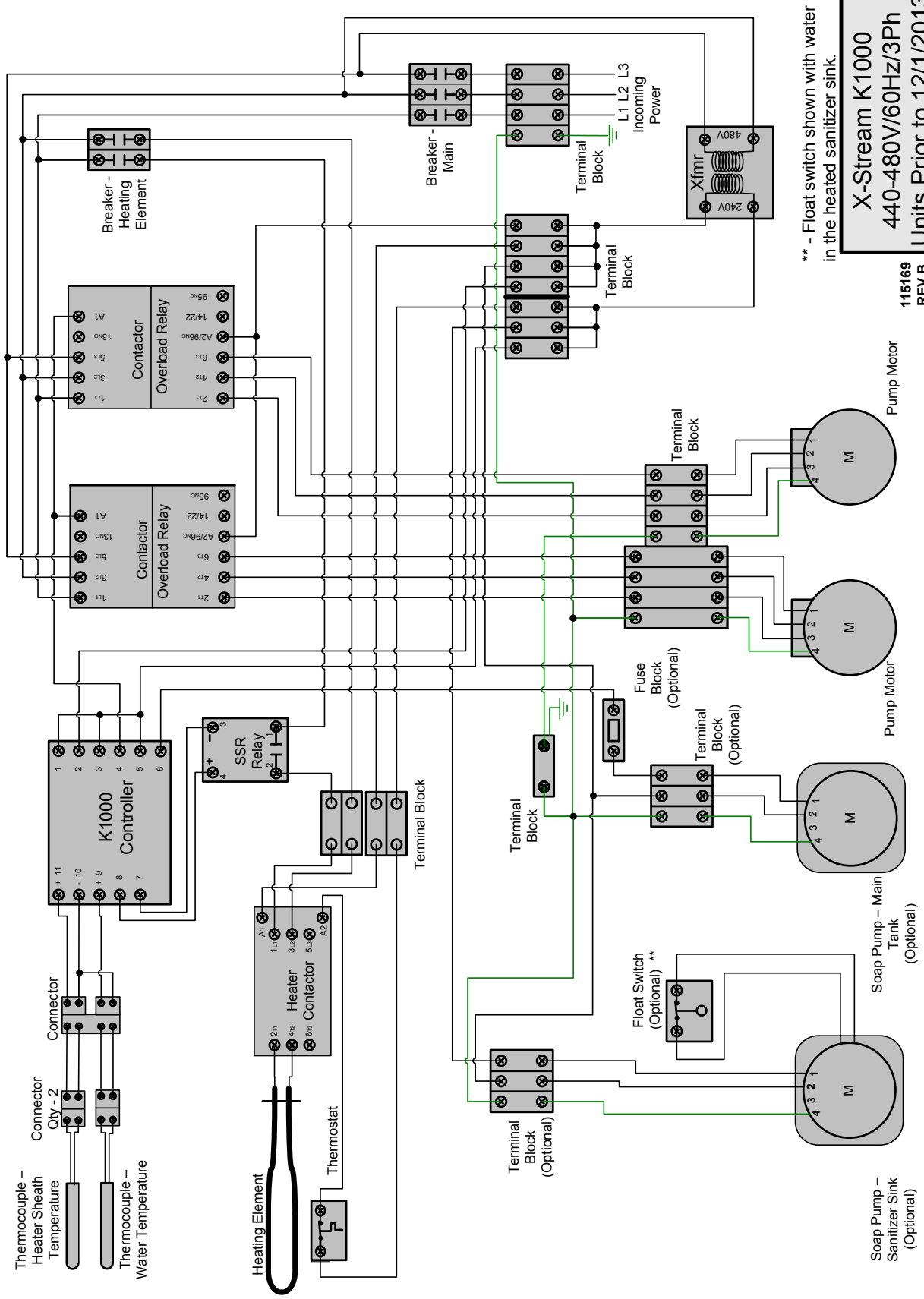

** - Float switch shown with water in the heated sanitizer sink.

X-Stream K1000
440-480V/60Hz/3Ph
Units Prior to 12/1/2013

115169
 REV B

FOR SUPPLY CONNECTIONS, USE WIRES RATED FOR AT LEAST 90°C (194°F). USE COPPER CONDUCTORS ONLY.

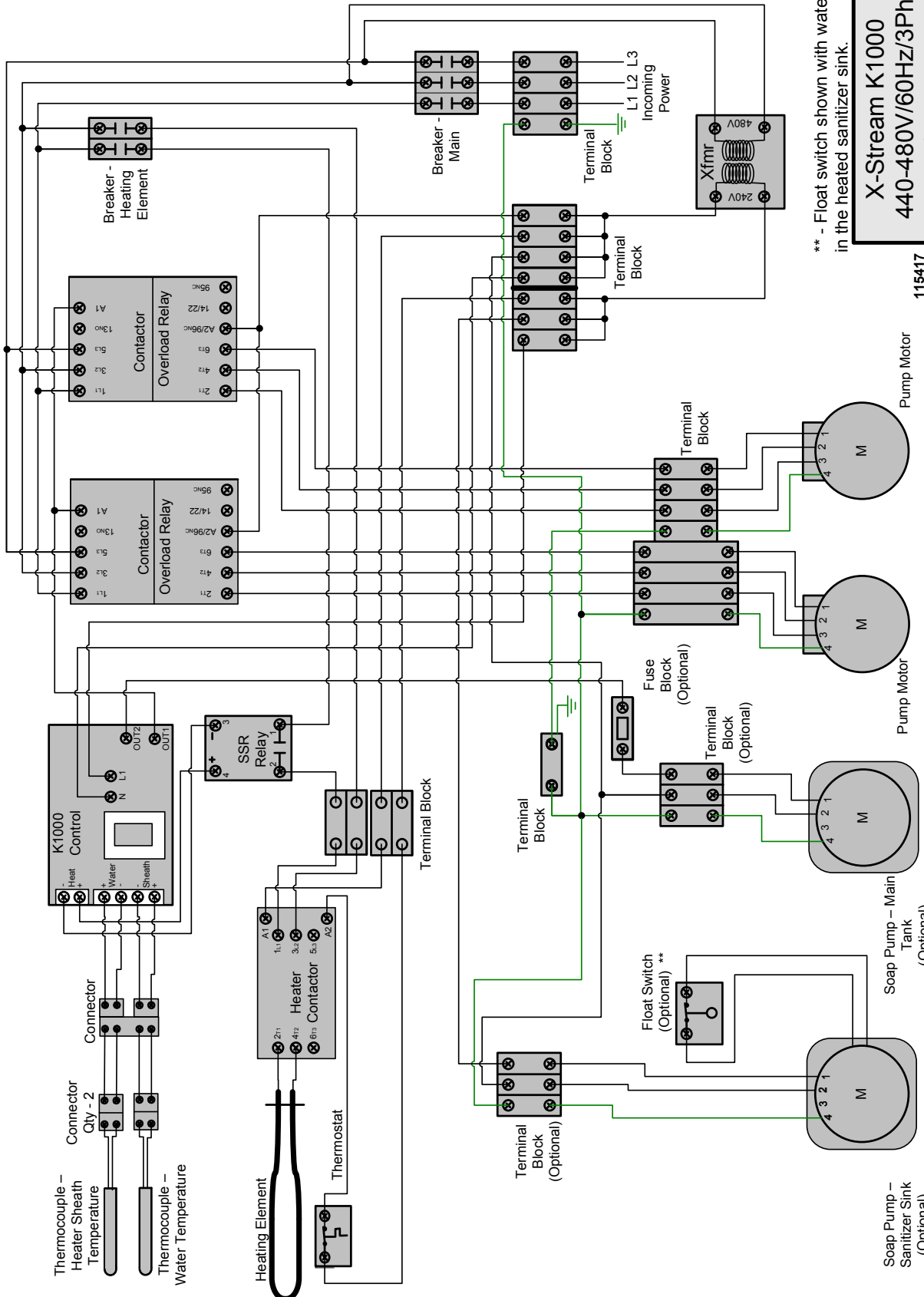

** - Float switch shown with water in the heated sanitizer sink.

**X-Stream K1000
440-480V/60Hz/3Ph
Units After 12/1/2013**

115417
REV A

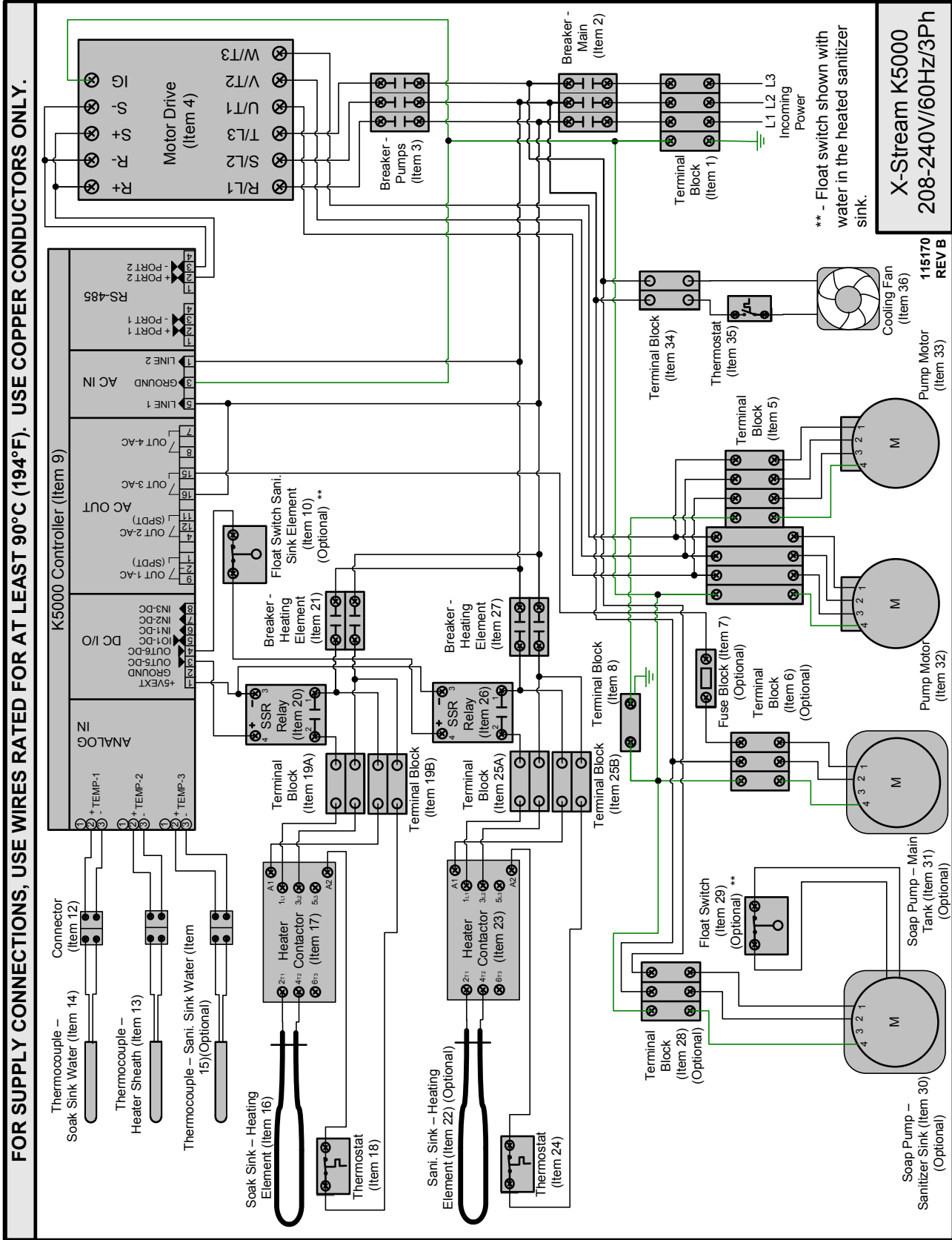

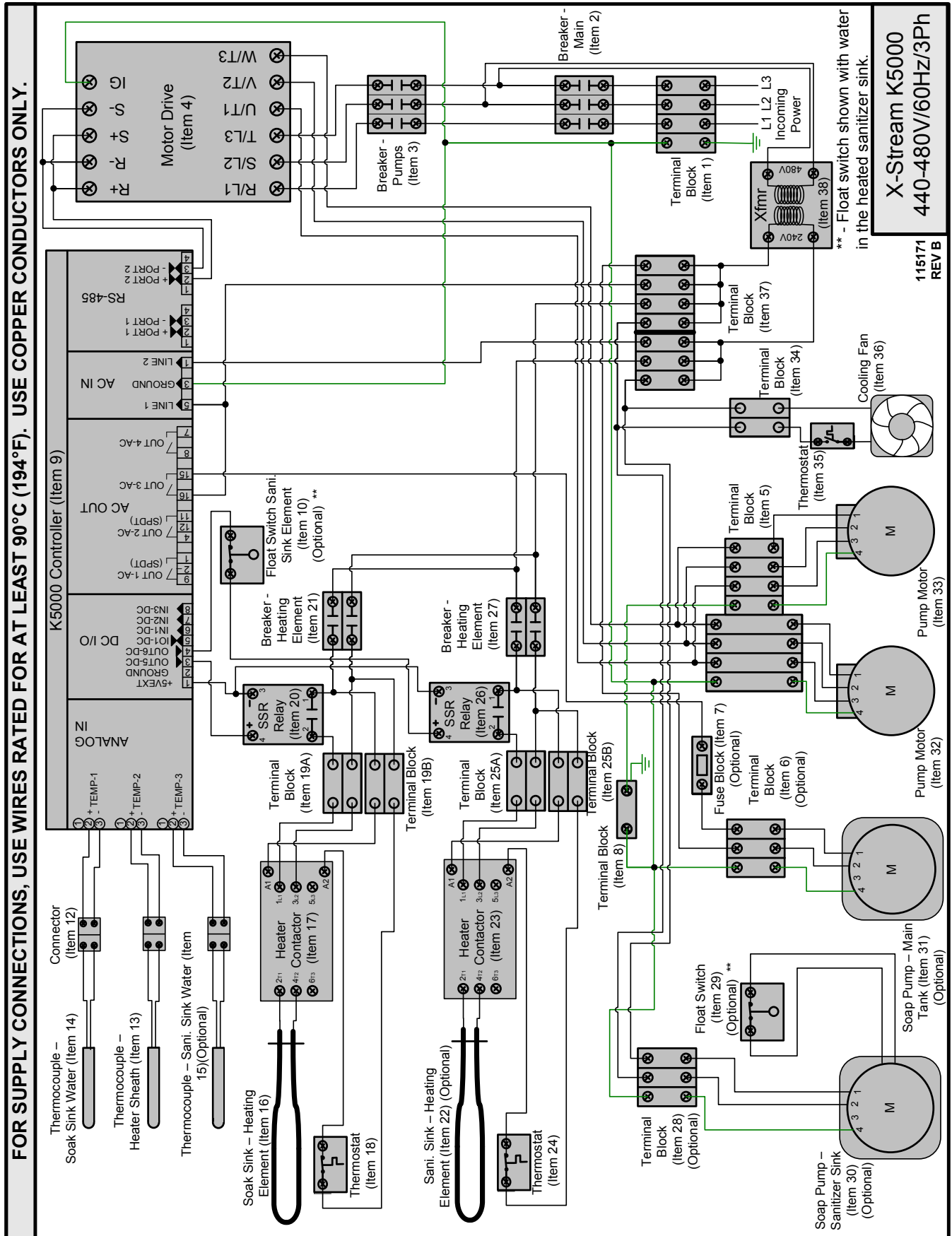

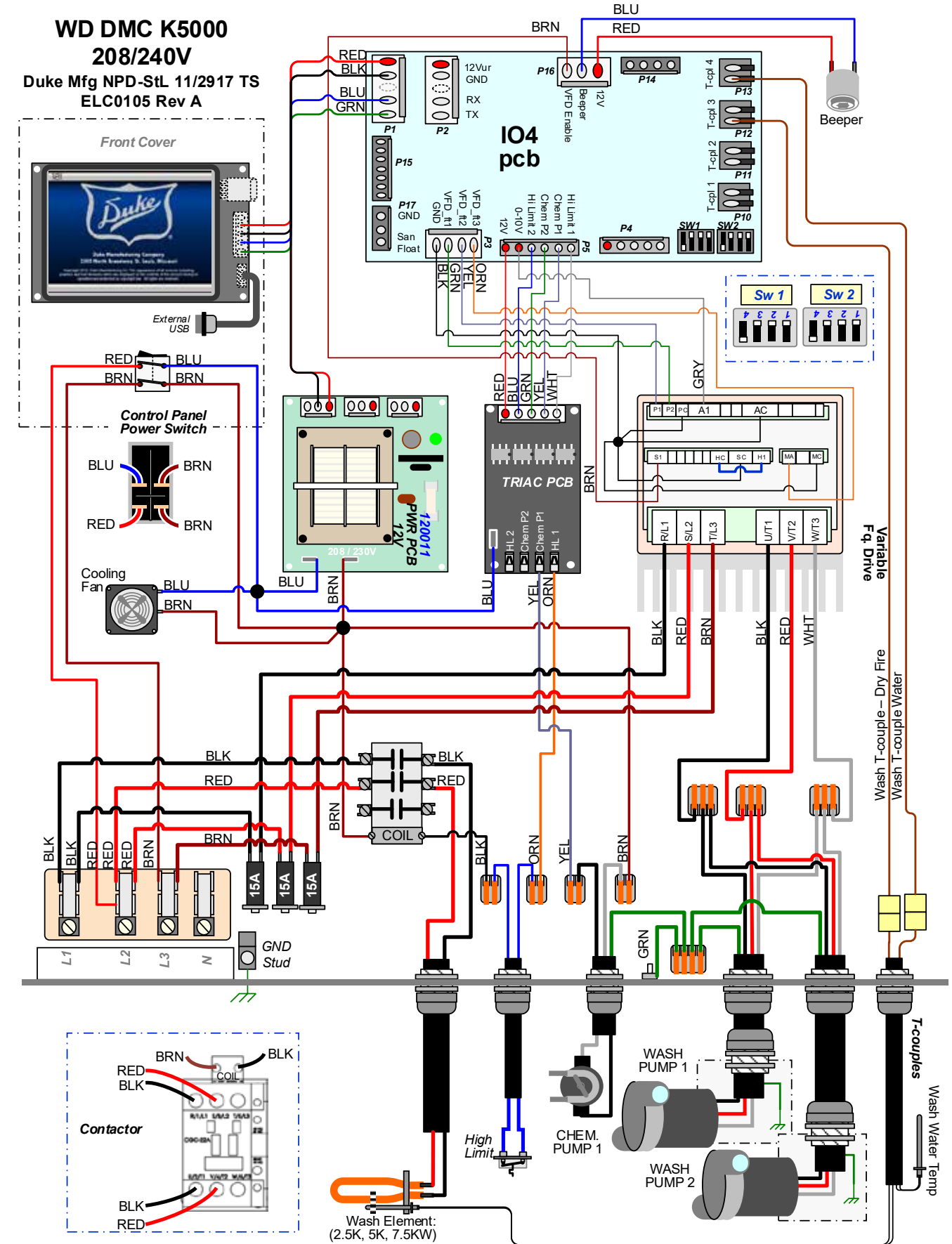

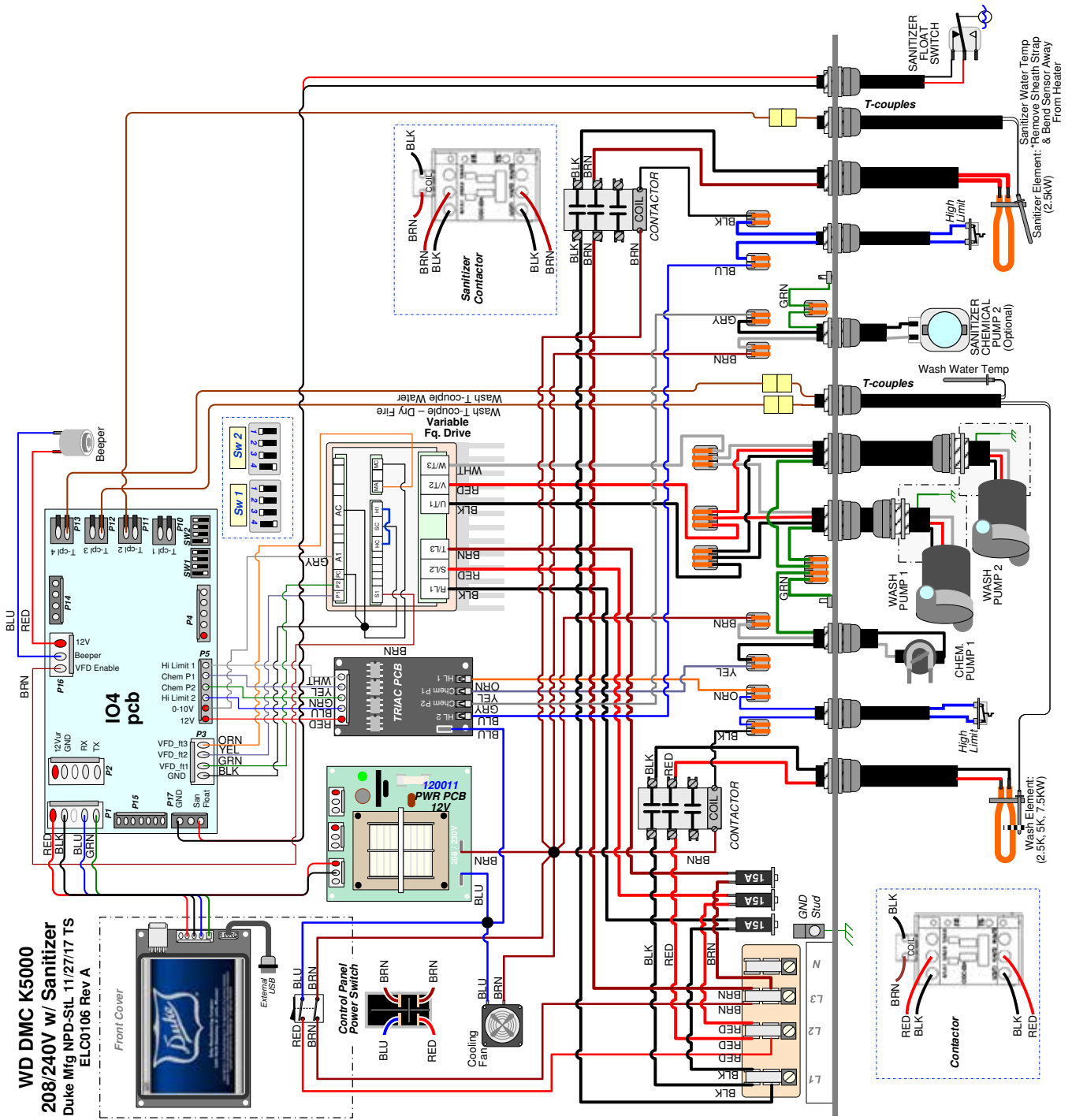

DMC K5000
208/240V Retrofit WD
 Duke Mfg NPD-StL 11/29/17
 ELC0245 Rev A

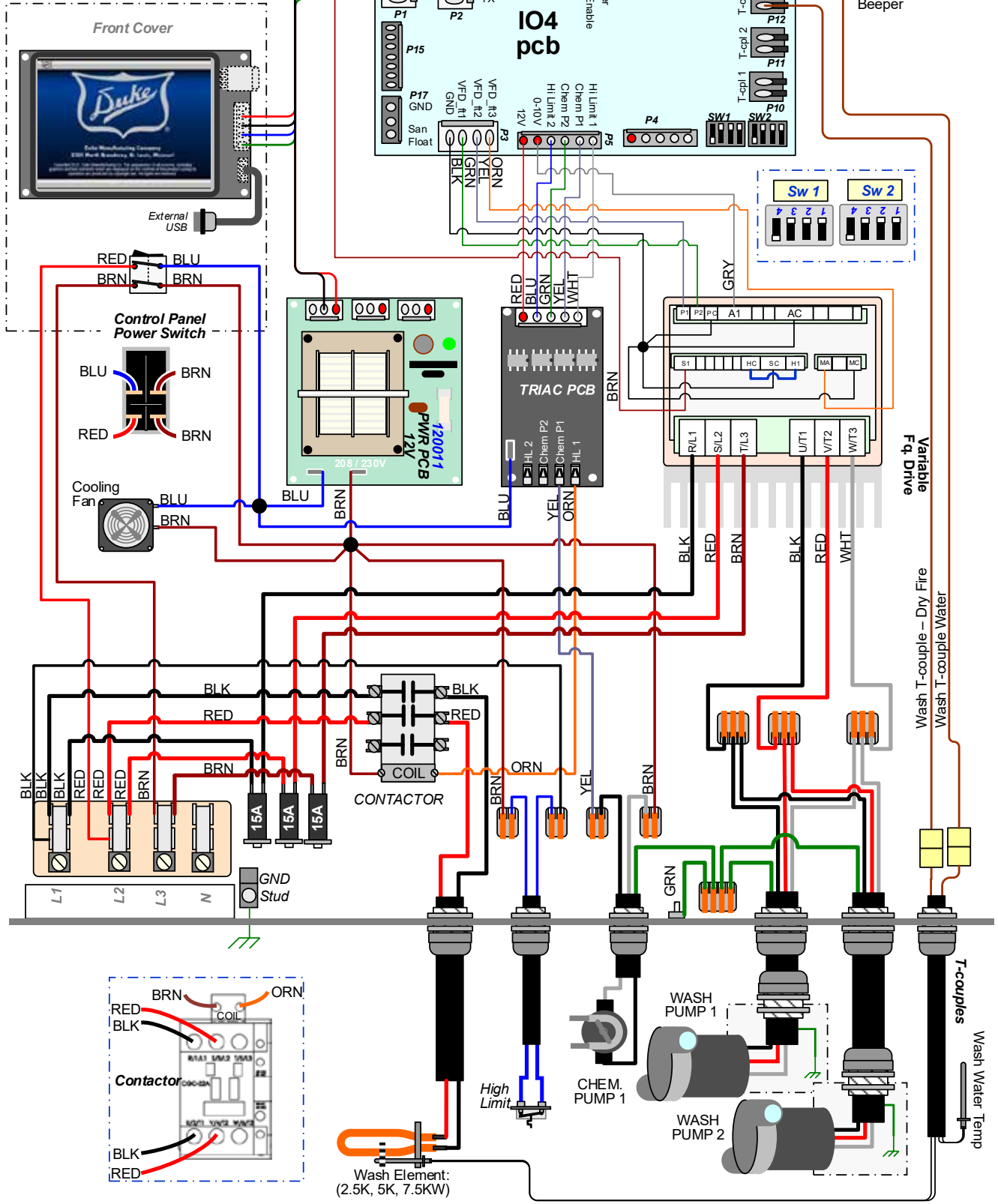

NOTES



Your Solutions Partner

Duke Manufacturing Company

2305 N. Broadway
St. Louis, MO 63102
Phone: 314-231-1130
Toll Free: 1-800-735-3853
Fax: 314-231-5074
www.dukemfg.com