

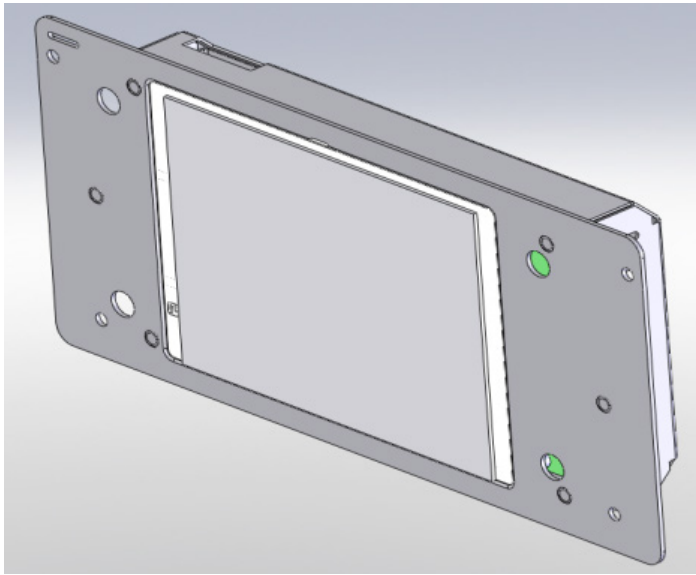

Your Solutions Partner

INSTALLATION INSTRUCTIONS

Replacement Instructions for ELC0017-3 Kit#514609



This kit contains:

- ELC0017-3 Main Control Module Assembly
- 512418 Strap, Disposable Wrist ESD

Items required for this installation:

- #2 Phillips Screw Driver
- 11/32" Nutdriver
- ESD Wrist Strap (included in kit)

This manual is Copyright © 2017 Duke Manufacturing Co. All rights reserved.
Reproduction without written permission is prohibited. Duke is a registered
trademark of the Duke Manufacturing Co.

Duke Manufacturing Co.

2305 N. Broadway
St. Louis, MO 63102
Phone: 314-231-1130
Toll Free: 1-800-735-3853
Fax: 314-231-5074

www.dukemfg.com

Replacement of ELC0017-3 Control Module

Removal of Old Control

Step 1 Verify recipe settings (recipe names and set points) with store staff prior to replacement. Record recipe setting for reference to reprogram any variance in recipes names and set points on the new control after replacement

WARNING HAZARDOUS VOLTAGE
CAUTION RISK OF ELECTRIC SHOCK

Step 2 Turn OFF the unit's Power. Disconnect unit from Main Voltage Supply using lockout/tagout procedures if required.

Step 3 Loosen, but do not remove the bottom and rear screws on each side of the slide out. Remove top front screws. (Left side Shown below)



Step 4 Slide the control panel forward and tilt down the control panel.

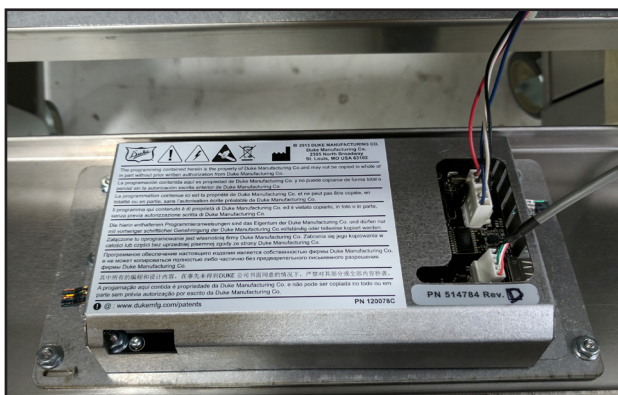

Step 5 Place ESD strap on wrist and tighten. Strap must be tight around wrist to be effective.

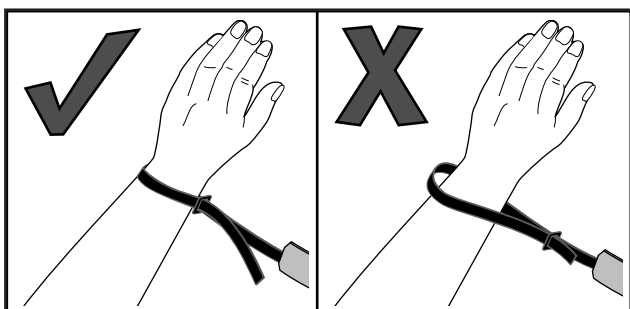

Step 6 Connect ESD Wrist strap to Unit on a good earth ground.

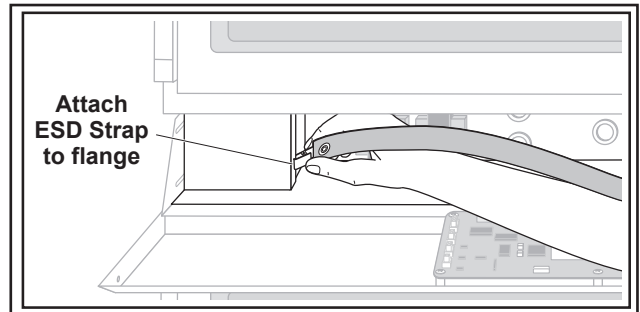

Step 7 Unplug the two connectors on the back of the Main Control assembly in the unit.

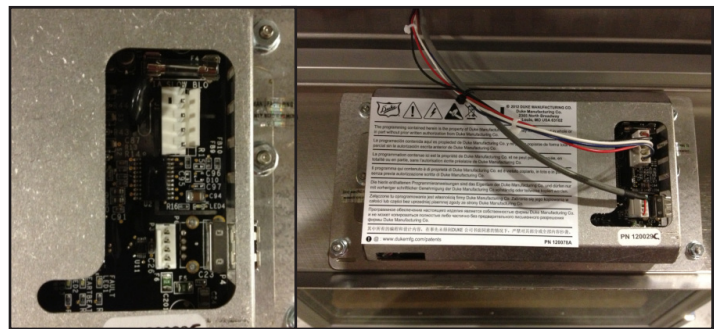

Step 8 Remove the outer 4 corner retaining nuts that mount the Main Control Module Assembly to the inner controls panel and remove control.

WARNING: Do not remove the center nuts or PCB cover of the Main Control Module Assembly. Warranty may be voided if cover has been removed or tampered with.



Replacement of ELC0017-3 Control Module

Installation of New Control

Step 1 Following proper ESD procedures, remove the replacement Main Control Module Assembly from the shipping box. Visually inspect the new Main Control Module Assembly for damage.

Note: If damage is identified, do not install the new control and immediately contact Duke Service Department for instruction.

Step 2 A display glass protector must be removed from the new Main Control Module Assembly before installing. The protector is a clear transparent plastic layer over the glass which is easily removed by hand. Contact Duke Service if you have question about the glass protector.

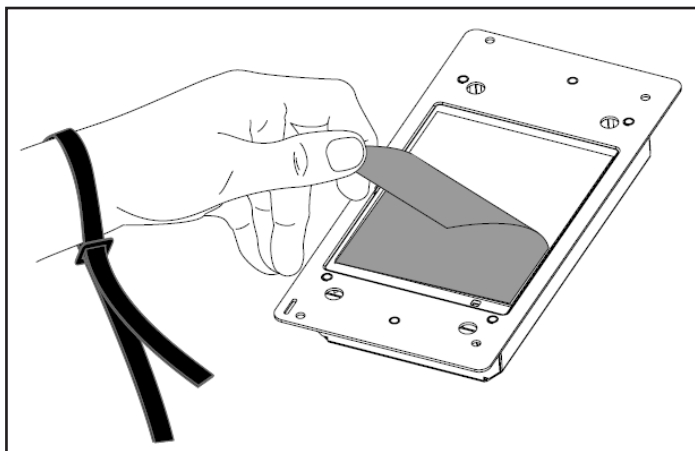

Step 3 To prevent static cling between the display and overlay, lightly dust the display glass with baby powder or talc powder. (not provided) Gently remove powder by brushing with a cosmetic brush (as shown to right). **Do not wipe the display with hands or any cloth as this may scratch the glass. Additionally, do not put any powder on the overlay.**



Step 4 Place the new Main Control Module Assembly on the studs. Verify the new Main Control Module display is centered in the control panel window. Re-install the 4 retaining nuts and reconnect the 2 PCB header connections.

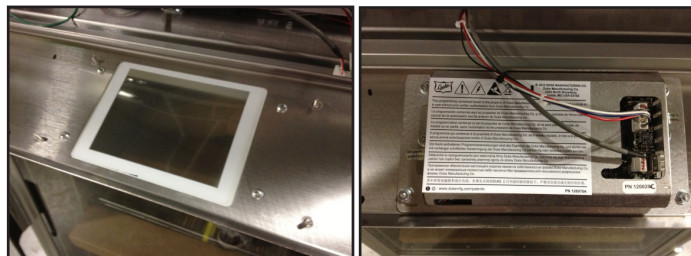

NOTE: Once the new control board is secured in place the ESD strap can be removed.

Installation Verification

Step 1 Turn ON the power switch and verify the LED indicators on the new Main Control Module PCB Assembly are active (viewed through the rear cover window. The PCB LED's will activate as the control boots and while running. Go to the Troubleshooting Guide if LEDs do not activate.

Step 2 Tilt up and slide back the control panel. Replace the Top 2 screws and tighten all 8 screws on both sides. Verify the Duke logo screen or the "gray" button start screen is properly displayed..

NOTE: Verify wiring is not trapped or visible under the controls panel after fully slid into position.

Step 3 Turn OFF and back ON the power switch while watching the control display. Record the software version identifier (Example "A005.88F") at the bottom of the Duke Logo screen. Repeat Off/On cycle if the software version I.D. is missed during the automatic logo screen view.

Step 4 From the "gray" screen, select a recipe and verify the Oven lights turn ON and verify fault messages are not displayed in the top tool bar of the display. Go to the Troubleshooting Guide if Oven lights do not turn ON.

Replacement of ELC0017-3 Control Module Installation Verification - continued

Step 5 Touch/select the top right "info" button (circled exclamation point) on the display. Touch/select the upper left "User" icon. Touch/select the "System Status" button and verify input levels and output loads are functioning as expected.

Step 6 Exit to the PIN code screen and program the prior recorded recipe names and set points if they are different from the new Main Control Module Assembly's recipe settings.

Step 7 Allow unit to run until Conditioning or Preheat cycles are complete and the Oven is in a "READY" mode. Verify the Oven temperature reasonably correlates with other temperature measurement equipment.

NOTE: The units controls and sensors are high precision and should not require recalibration. Up to 10% variances between the measurement device and the units controls are most probably due to measurement equipment accuracy and not the units control system. Contact Duke Service should any sensor calibration questions arise.



Your Solutions Partner

Duke Manufacturing Co.

2305 N. Broadway

St. Louis, MO 63102

Phone: 314-231-1130

Toll Free: 1-800-735-3853

Fax: 314-231-5074

www.dukemfg.com