



Your Solutions Partner

Installation Instructions

Daypart Switch Panel Kit 600518 MUHC-34



**Please read this manual completely before attempting
to install, operate or service this equipment**

*This manual is Copyright © 2017 Duke Manufacturing Co. All rights reserved.
Reproduction without written permission is prohibited. Duke is a registered
trademark of the Duke Manufacturing Co.*

Duke Manufacturing Co.

**2305 N. Broadway
St. Louis, MO 63102
Phone: 314-231-1130
Toll Free: 1-800-735-3853
Fax: 314-231-5074**

www.dukemfg.com

**P/N 161448
REV A Date 08/23/2017**

IMPORTANT SAFETY INSTRUCTIONS

Throughout this manual, you will find the following safety words and symbols that signify important safety issues with regards to operating or maintaining the equipment.



Indicates a hazardous situation which, if not avoided, could result in death or serious injury.



Indicates a hazardous situation which, if not avoided, could result in minor or moderate injury.



Indicates Important Information



Indicates electrical shock hazard which, if not avoided, could result in death or serious injury and/or equipment damage.



Indicates hot surface which, if not avoided, could result in minor or moderate injury.

In addition to the warnings and cautions in this manual, use the following guidelines for safe operation of the unit.

- Read all instructions before using equipment.
- For your safety, the equipment is furnished with a properly grounded cord connector. Do not attempt to remove or disconnect the grounded connector.
- Install or locate the equipment only for its intended use as described in this manual.
- Do not operate this equipment if it has a damaged cord or plug, if it is not working properly, or if it has been damaged or dropped.
- This equipment should be serviced by qualified personnel only. Contact the nearest Duke authorized service facility for adjustment or repair.
- Do not block or cover any openings on the unit.
- Do not immerse cord or plug in water.
- Keep cord away from heated surfaces.
- Do not allow cord to hang over edge of table or counter.

The following warnings and cautions appear throughout this manual and should be carefully observed.

- Turn the unit off, disconnect the power source and allow unit to cool down before performing any service or maintenance on the unit.
- The unit should be grounded according to local electrical codes to prevent the possibility of electrical shock. It requires a grounded receptacle with dedicated electrical lines, protected by fuses or circuit breaker of the proper rating, in accordance with all applicable regulations.
- Disposal of the unit must be in accordance with local environmental codes and/or any other applicable codes.
- This appliance is not intended for use by persons (including children) with reduced physical, sensory or mental capabilities, or lack of experience and knowledge, unless they have been given supervision or instruction concerning use of the appliance by a person responsible for their safety.



NEW DAYPART PANEL INSTALLATION

Step 1

Unplug unit and allow to cool down if hot.

CAUTION

If not completed a hazardous situation which could result in minor or moderate injury.

Step 2

On the control side, remove the six screws holding the side panel in place.

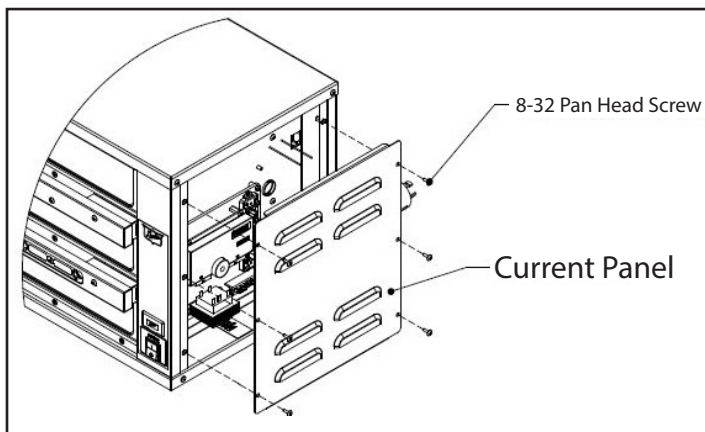

Step 3

Disconnect the wire harness from the lower relay on the control panel.

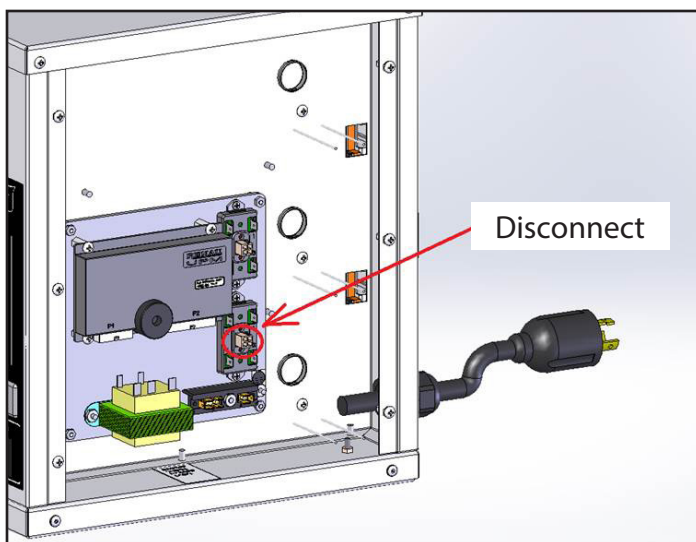

Step 4

Plug the smaller end of the wire harness from the panel into the relay where you unplugged the harness in step 3.

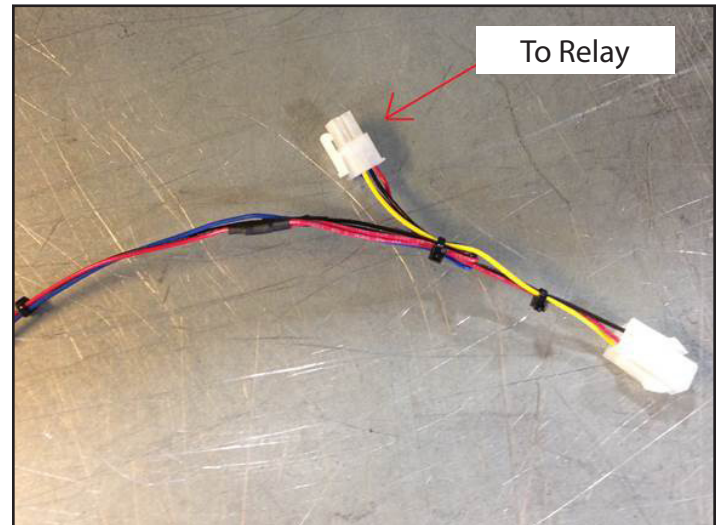

Step 5

Plug the larger end of the wire harness from the panel into the main wire harness. The end you unplugged in step 3.

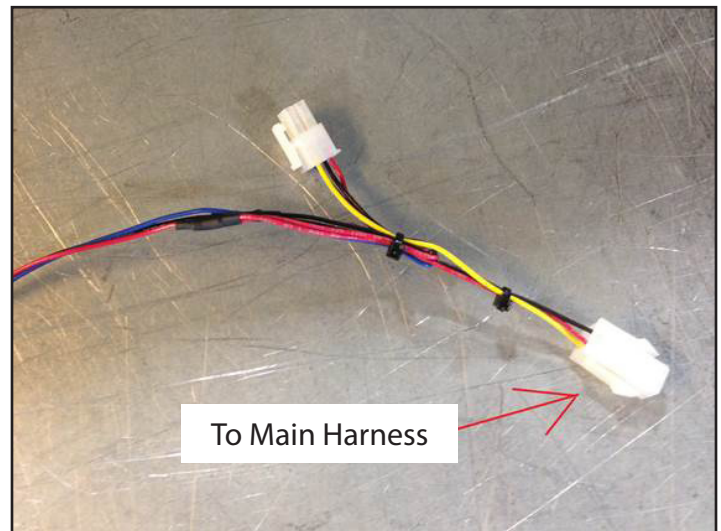

NEW DAYPART PANEL INSTALLATION - continued

Step 6

Making sure all wires are secured. Attach new panel using the 8-32 screws removed in **step 2**.

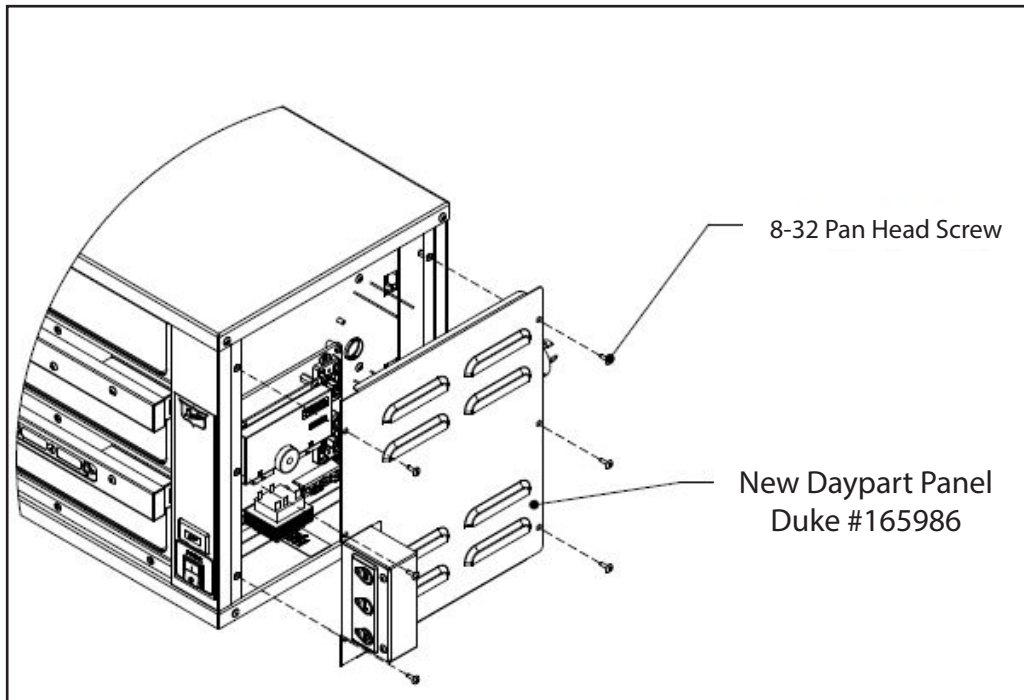

Step 7

Turn unit on and make sure unit is working properly and reaches setpoint temperatures. Cycle unit through dayparts to make sure recipes update.



Your Solutions Partner

Duke Manufacturing Co.

2305 N. Broadway

St. Louis, MO 63102

Phone: 314-231-1130

Toll Free: 1-800-735-3853

Fax: 314-231-5074

www.dukemfg.com