



Your Solutions Partner

# Installation and Operation Manual

## Proofer Baking Center with Touch Screen Control

### Models:

PBC-6/18M

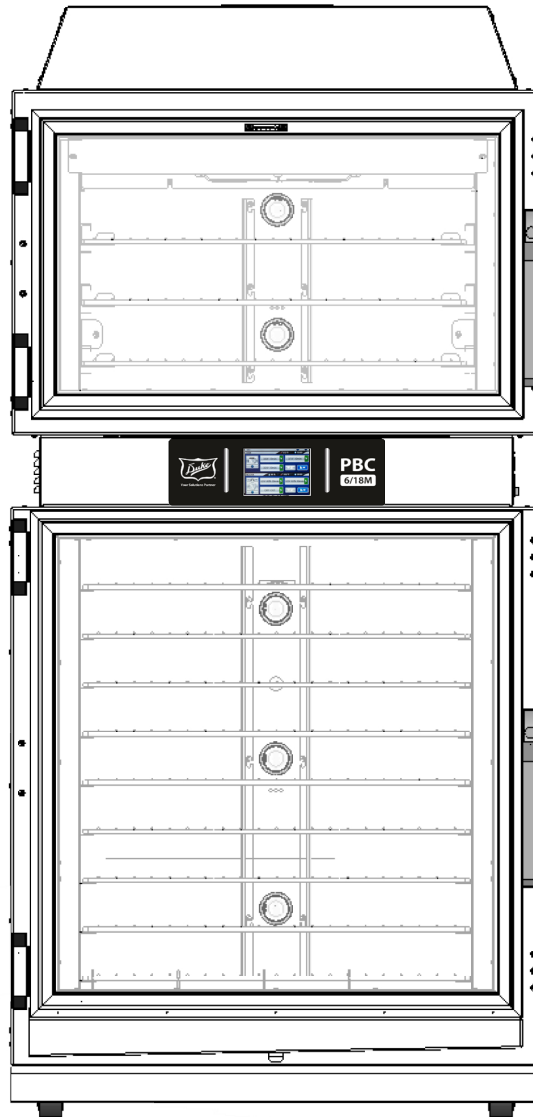

**CAUTION:** Please read this manual completely before attempting to install, operate or service this equipment

 **WARNING:** Cancer and Reproductive Harm - [www.p65warnings.ca.gov](http://www.p65warnings.ca.gov)

*This manual is Copyright © 2020 Duke Manufacturing Co. All rights reserved.  
Reproduction without written permission is prohibited. Duke is a registered  
trademark of the Duke Manufacturing Co.*

P/N 529063  
REV B 01/03/2020



## TABLE OF CONTENTS

Important safety instructions ..... 2

Introduction ..... 4

Specifications..... 4

Main features ..... 6

Installation ..... 8

Control definitions ..... 12

Operating Instructions ..... 13

Baking tips ..... 16

Programming controls ..... 18

Care and cleaning .....20

Wire Diagram .....22

Troubleshooting .....23

Preventive maintenance.....24

### IMPORTANT SAFETY INSTRUCTIONS

Throughout this manual, you will find the following safety words and symbols that signify important safety risks with regards to operating or maintaining the equipment.



**Indicates a hazardous situation which, if not avoided, could result in death or serious injury.**



**Indicates a hazardous situation which, if not avoided, could result in minor or moderate injury.**



**Indicates Important Information**



**Indicates electrical shock hazard which, if not avoided, could result in death or serious injury and/or equipment damage.**



**Indicates hot surface which, if not avoided, could result in minor or moderate injury.**



**Indicates rotating fan blade hazard which, if not avoided, could result in minor or moderate injury.**

***In addition to the warnings and cautions in this manual, use the following guidelines for safe operation of the unit.***

- Read all instructions before using equipment.
- For your safety, the equipment is furnished with a properly grounded cord connector. Do not attempt to remove or disconnect the grounded connector.
- Install or locate the equipment only for its intended use as described in this manual.
- Do not use corrosive chemicals on this equipment.
- Do not operate this equipment if it has a damaged cord or plug, if it is not working properly, or if it has been damaged or dropped.
- This equipment should be serviced by qualified personnel only. Contact the nearest Duke authorized service facility for adjustment or repair.
- Do not block or cover any openings on the unit.
- Do not immerse cord or plug in water.
- Keep cord away from heated surfaces.
- Do not allow cord to hang over edge of table or counter.

***The following warnings and cautions appear throughout this manual and should be carefully observed.***

- Turn the unit off, disconnect the power source and allow unit to cool down before performing any service or maintenance on the unit.
- Unit may start operation with inadvertent contact with touch screen display or from other extraneous sources. Turn off all poles mains disconnects should abnormal or unwanted operation occur.
- Install the Restraining Device Kit to prevent damage to main supply connections.
- The procedures in this manual may include the use of chemical products. You must read the Material Safety Data Sheets before using any of these products.
- The unit should be grounded according to local electrical codes to prevent the possibility of electrical shock. It requires a grounded receptacle with dedicated electrical lines, protected by fuses or circuit breaker of the proper rating, in accordance with all applicable regulations.
- Disposal of the unit must be in accordance with local environmental codes and/or any other applicable codes.
- This appliance is not intended for use by persons (including children) with reduced physical, sensory or mental capabilities, or lack of experience and knowledge, unless they have been given supervision or instruction concerning use of the appliance by a person responsible for their safety.

## INTRODUCTION

The Duke PBC (Proofer Baking Center) with Touch Screen Control was developed in response to Customer's need for uniform baking capabilities and to provide consistently high, quality just-baked product.

The Duke Proofer Baking Center utilizes Duke's **unique directional convection airflow technology** that provides even heat distribution and a uniform bake without the need for turning pans during the bake cycle. This enhances the quality and consistency of the baked products, reduces food scrap and waste while simplifying operating process.



The low profile oven won't block the view of menu boards and will easily roll through a standard height door. The oven and proofer doors are field reversible with a drip channel on the proofer door, which prevents water from dripping on the floor.

Full-width doors on the oven and proofer help to display and merchandise fresh baked bread to the customer.

The full-width oven and proofer cavity will accept standard half-size or full-size sheet pans.

The PBC models feature a simple color LCD touch screen control that allows users to quickly select from pre-programmed recipes for baking and proofing. Advanced features are also included for custom recipes plus user accessible information for operating instructions and maintenance information.

# SPECIFICATION

<b>Compliance Declaration - PBC-M Proofer Oven with Touch Screen Control</b>		
 LISTED COMMERCIAL COOKING APPLIANCE	Standard: UL197	File: KNGT.E17421
 INDEXER COMMERCIAL APPAREIL DE QUISINE	Standard: CSA-C22.2 No. 109	File: KNGT7.E17421
	Standard: ANSI / NSF 4	File: TSQT.E157479

<b>Line Ratings - PBC-6/18M Proofer Oven with Touch Screen Control</b>				
Line Supply Voltage (V)	Line Supply Frequency (Hz)	Line Phase Configuration	Total Maximum Line Power Watts (W)	Total Maximum Line Current Amps (A)
208	60	Single Phase	6650	32
208	60	3 ~	6650	32 ▲ 1
240	60	Single Phase	7200	30
240	60	3 ~	7200	30 ▲ 1
▲ 1 L1<15A, L2<15A, L3<25A		▲ 2: L1<15A, L2<15A, L3<15A, N = Comm		

# MAIN FEATURES

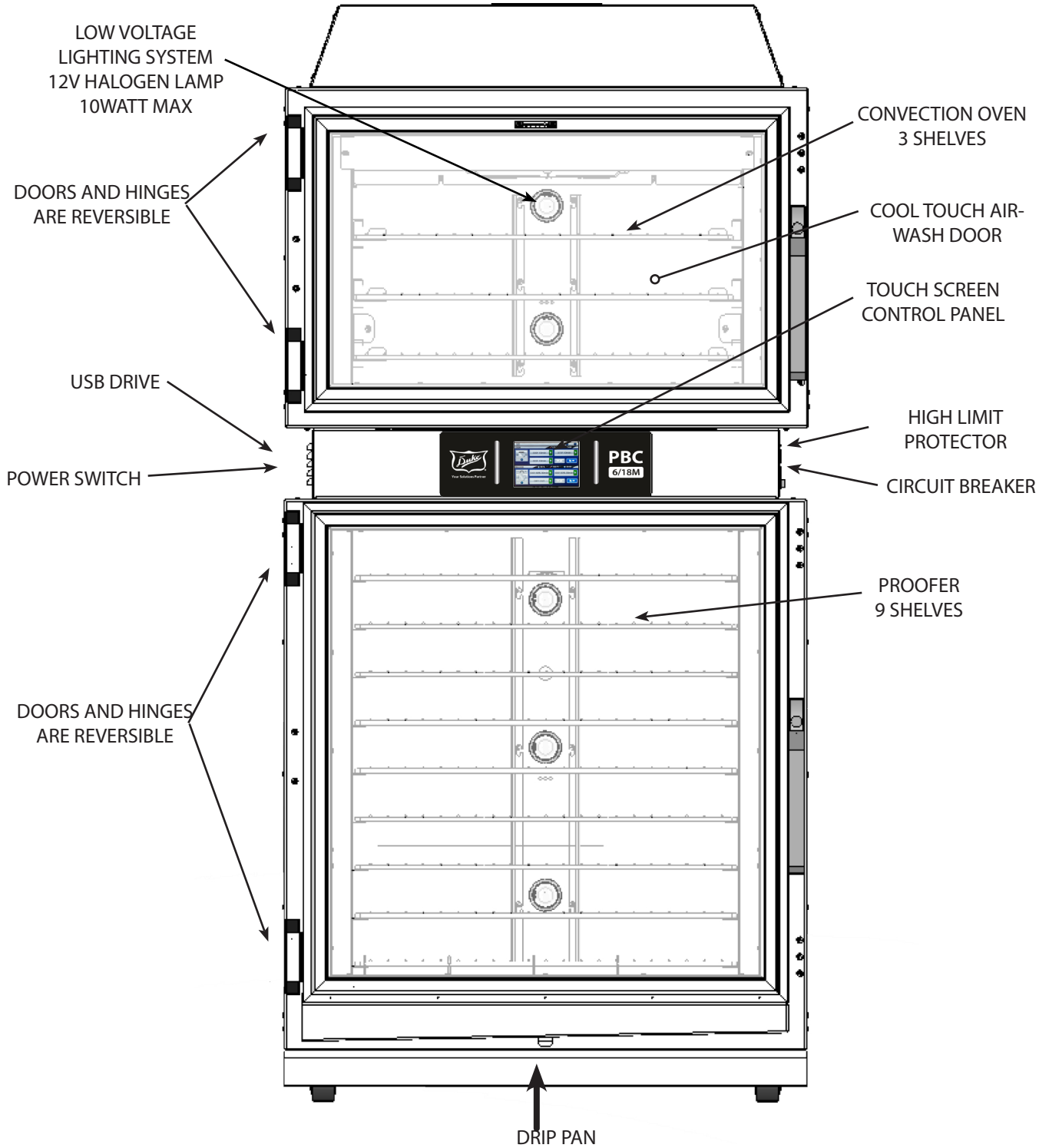

### FRONT VIEW - DEMINSIONS

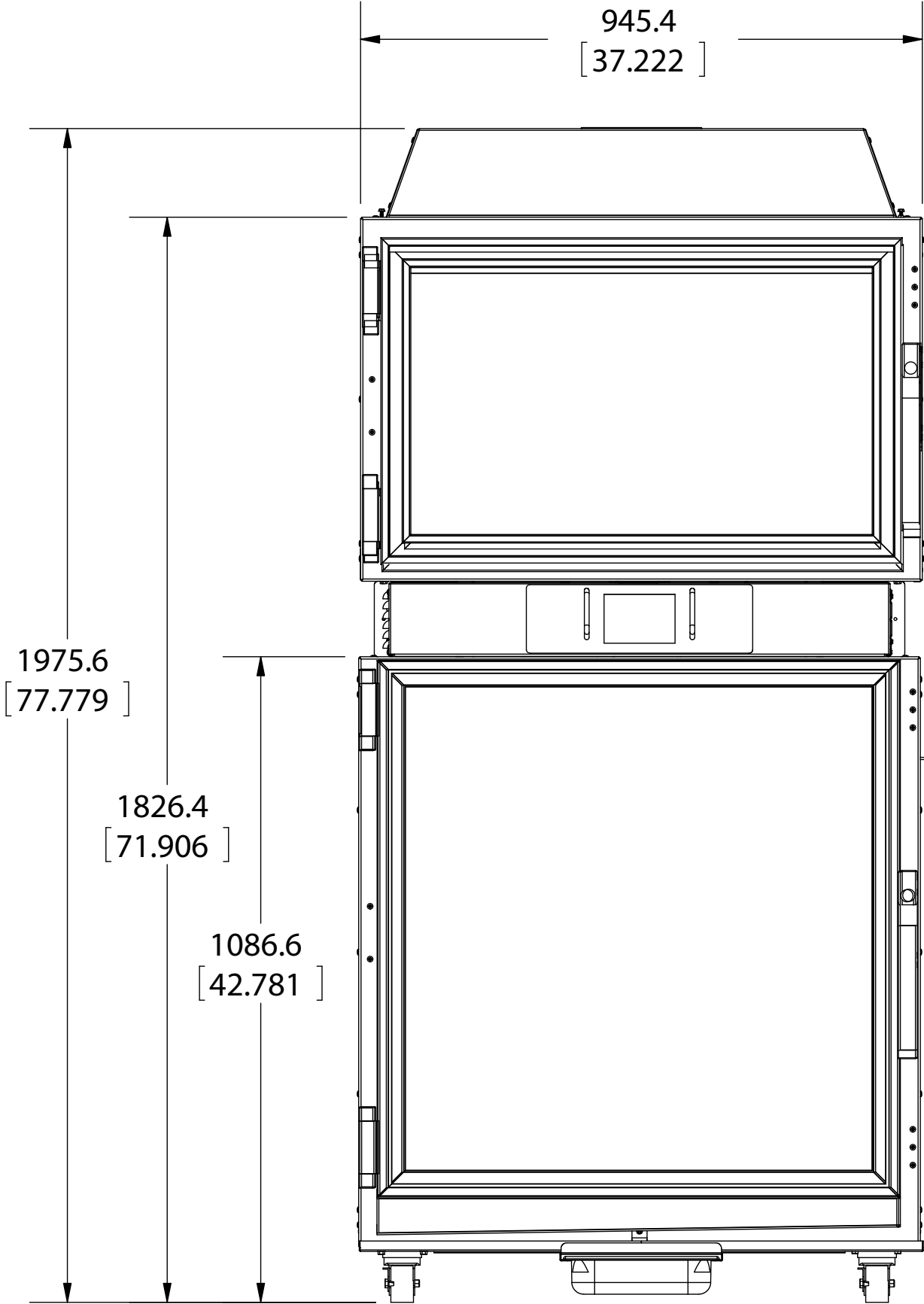

## SIDE VIEW - DEMINSIONS

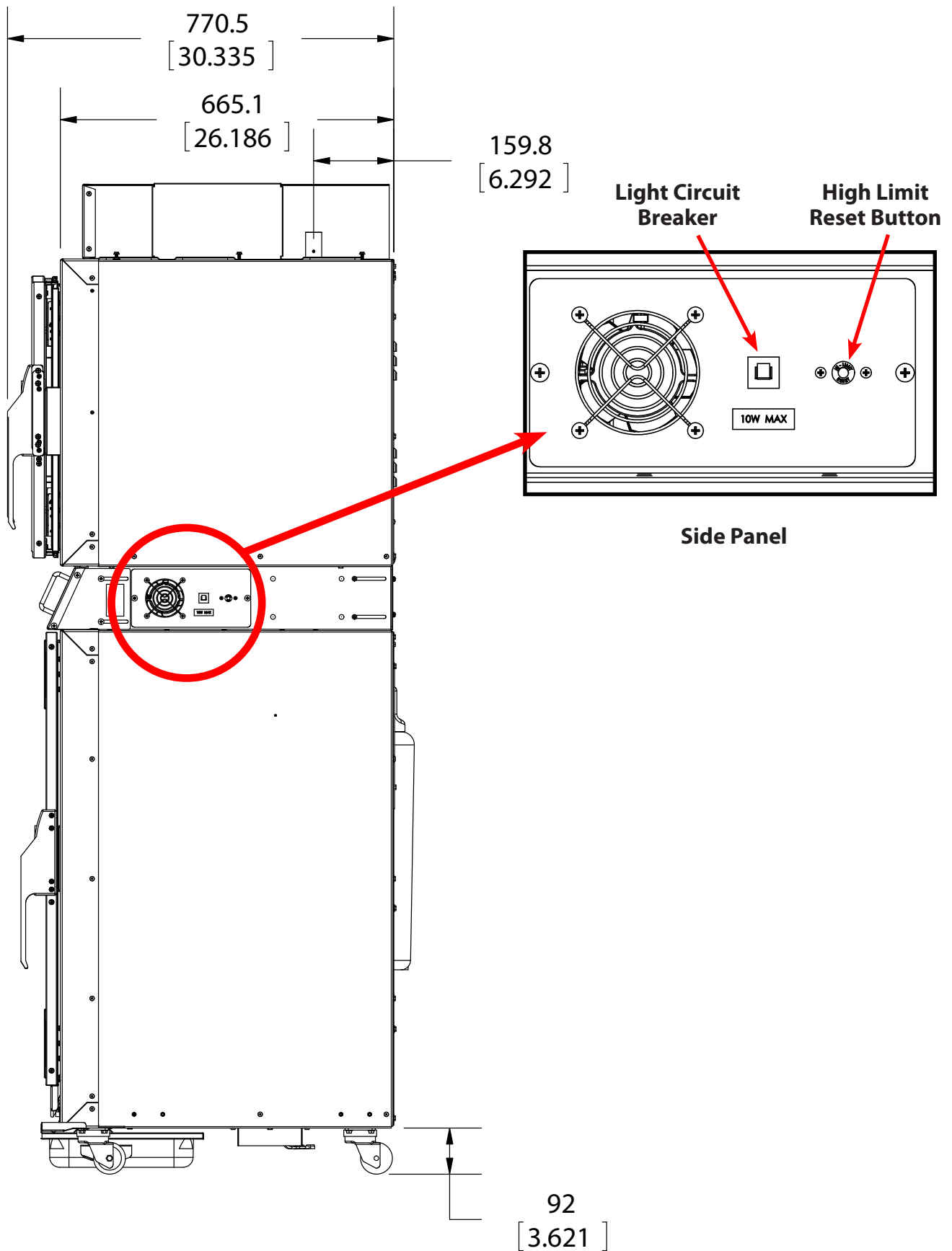

# BACK VIEW - DEMINSIONS



**NOTE: WATER SOURCE REQUIRED FOR PROOFER.**

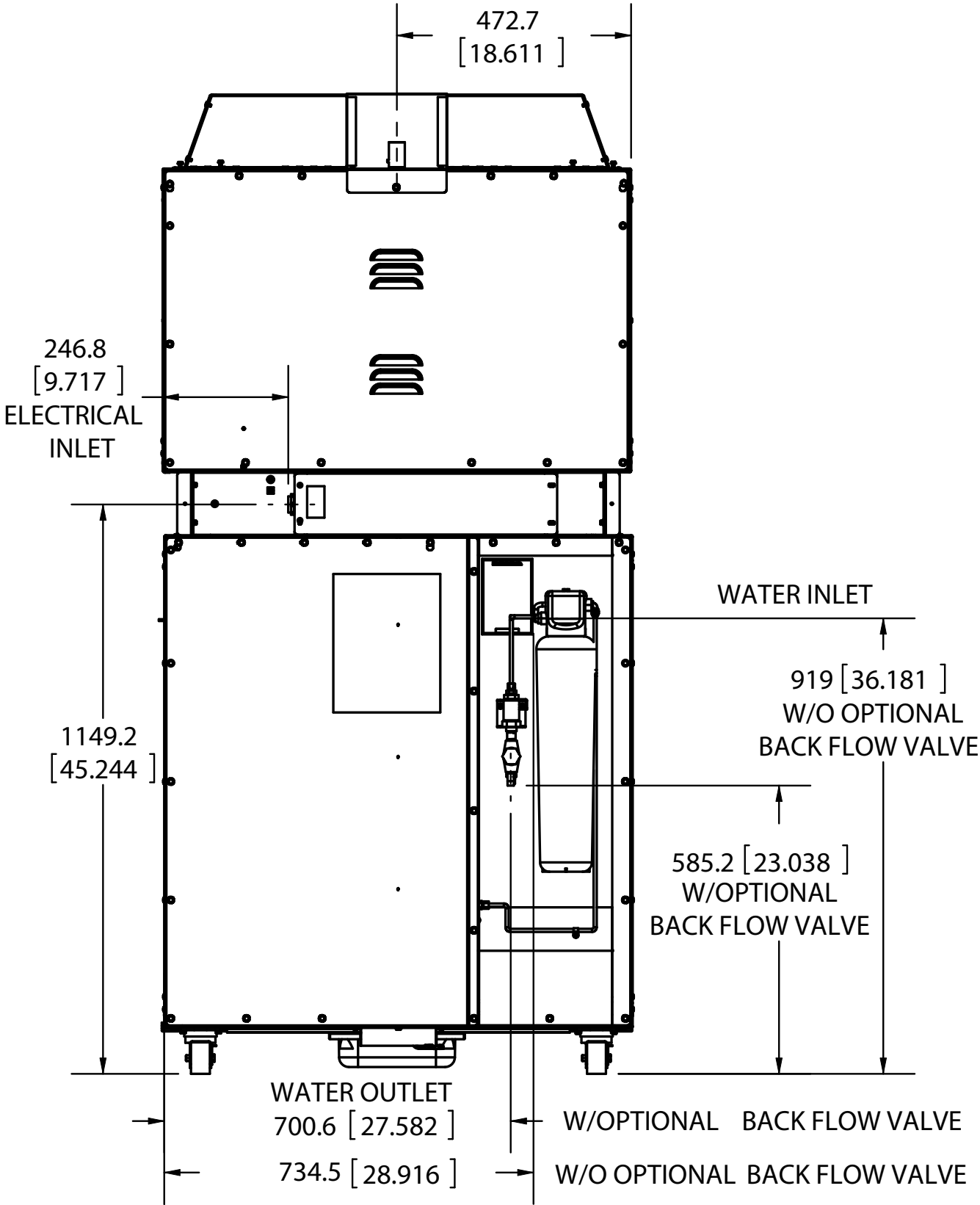

# INSTALLATION

## UNPACKING UNIT

Inspect the shipping carton and/or container, carefully noting any exterior damage on the delivery receipt; also note any damage not evident on the outside of the shipping container (concealed damage). Contact the carrier immediately and file a damage claim with them. Save all packing materials when filing a claim. Freight damage claims are the responsibility of the purchaser and are not covered by the warranty.

- Follow the instructions on the Carton Box for unpacking the unit.
- Inspect unit for damage such as, broken glass, etc.
- Report any dents or breakage to source of purchase immediately.
- **Do not attempt to use unit if damaged.**
- Remove all materials from unit interior.
- If unit has been stored in extremely cold area, wait a few hours before connecting power.

## UNIT PLACEMENT

- Do not install unit next to source of heat, such as deep fryer, etc.
- Install unit on level surface floor.
- Minimum Clearance of 6" (152mm) must be maintained between the unit and any combustible substance.
- Either side of the unit must remain open for proper airflow for electrical component cooling. The rear of the unit and one side may be installed without clearance

## ELECTRICAL AND SUPPLY CONNECTIONS



**ELECTRICAL SHOCK HAZARD UNIT MUST BE SAFETY GROUNDED, EARTHED.**

**DO NOT MODIFY OR DEFEAT ELECTRICAL CONNECTIONS**

Connection of the unit to the mains supply **MUST** be performed by an authorized person in accordance with codes, standards, and laws governing the installation site using properly rated all poles mains protection, all poles mains disconnects, safety ground earthing, and shall be a minimum of 48" (1.2 meter) long to allow the equipment to be moved for cleaning.

USA and non-EU Countries must use flexible conduit within variances that may be required by local electric codes or regulations.

The Mains Supply safety / earth ground wire must be longer than mains conductors at the unit's interconnections to prevent stress under pull.

Contact Duke for service of IVS (Integrated Ventilation System) HO5RN supply interconnection.

## EXTERNAL EQUIPOTENTIAL



Terminal provides a connection for bonding to equipment enclosure.

## WATER SUPPLY CONNECTION



**NOTE: WATER SOURCE REQUIRED FOR PROOFER.**

This equipment must be installed in accordance with all applicable federal, state, and/or local plumbing codes having jurisdiction.

The water inlet utilizes ¼" (6.35mm), OD plastic tubing. Install the tubing in a manner to ensure there are no kinks, strains, or tight bends. Leave sufficient length to allow unit movement for service and cleaning.

The tubing should be cut square and be free of any deformations at the connection points. All burrs and sharp edges should be removed for proper connection.

Insert the tubing through the compression fitting with the threads pointing towards the end of the tubing.

Push the tubing into the fitting as far as it will go and tighten the nut with a ½" (12.7mm), wrench. Do not over-tighten the nut. If leaks occur, further tighten the fitting until the leakage stops.

## INSTALLATION - continued

### ELECTRICAL CONNECTION

1. This unit can be converted to other mains supply configurations by Duke Manufacturing approved service personnel. Call Duke Service Department for action if electrical rating tag information is not compatible with the available mains supply.
2. This unit is supplied with the national and international specified water supply interconnection. Backflow prevention protection is optionally supplied as a factory installed option or as an add-on kit. Local regulation variances or additional requirements must be evaluated prior to installation. New water supply line interconnection must be used when installing this unit. Maximum / minimum supply pressure specification is 65PSI (450KPa) / 40PSI (275KPa) for all system plumbing components. See **INSTALLATION OF WATER FILTER** section prior to water supply interconnect.
3. This appliance must be secured to building structure. A restraining device kit (#153586) provided with the unit limits the movement of the appliance without transmitting stress to the mains supply. Installation instructions are in the kit.

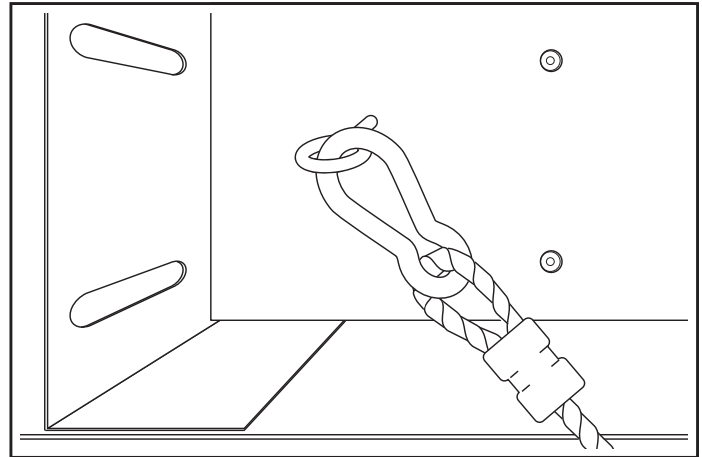

5. Check the swing of the door. The hinge side can be changed by referring to the **Reversing Oven Door Swing Direction section of this manual**.
6. Check the door seal and make sure both doors close completely. If they do not close and seal properly, refer to the **Door Gasket Adjustment section of this manual**.
7. Place the wire racks in the oven and proofer.
8. Unit can be mechanically attached to wall using optional wall-mounting brackets. Optional wall-mounting brackets are not required for safe operation of the unit. Refer to **Installation of Wall Brackets section of this manual** for the instructions on Installation of Wall Brackets to the wall.



### HAZARDOUS VOLTAGE RISK OF ELECTRIC SHOCK DISCONNECT POWER TO SERVICE COMPARTMENT

#### RESTRAINING DEVICE INSTALLATION



**THIS RESTRAINING DEVICE MUST ALWAYS BE CONNECTED WHEN THE APPLIANCE IS IN SERVICE. DISCONNECT ONLY FOR SERVICING AND/OR CLEANING, THEN RECONNECT WHEN THE APPLIANCE HAS BEEN RETURNED TO ITS NORMAL POSITION.**

4. **IMPORTANT:** A minimum clearance of 6" (152mm) from the top of unit to the ceiling must be provided. Unit may be installed with minimal clearance on one side and rear of the cabinet.

### TECHNICAL DESCRIPTION AND APPLICATION NOTES FOR PROOFER BAKING CENTER BACKFLOW PREVENTER SYSTEM

Check with your local authority having jurisdiction regarding approvals for connecting the Duke Proofer Baking Center to a potable water supply before making any plumbing connections. Plumbing code requirements vary, but European Union (CE) and other jurisdictions require a backflow prevention device that is factory-installed or available as a kit (P/N 600187). The backflow prevention device used on Duke Proofer Baking Center protects water supply systems by preventing the reverse flow of non-potable water into the potable domestic water system. The device consists of two independently acting check valves, internally

## INSTALLATION - continued

force-loaded to a normally closed position and designed/constructed to operate under intermittent or continuous pressure conditions.

The two main components of the Duke backflow preventer system are:

- Dual Check Valve type backflow preventer that conforms to ANSI/ASSE standard #1024 and is CSA standard B64.6 certified.
- Inlet water strainer equipped with 100-mesh screen and installed up stream of the backflow preventer. The screen is conveniently located on the rear panel of the proofer, below the backflow preventer, for easy access during cleaning/ replacement.

### Duke Manufacturing Co.

This equipment is intended to be connected to a potable water supply system under pressure and is to be installed with adequate backflow protection to comply with all applicable federal, state, and local codes.

Water supply pressure for proper operation shall be:  
Minimum 40 PSIG(275 KPa)  
Maximum 65 PSIG(448 KPa)  
measured at water line inlet to the equipment.

If so equipped, regular maintenance is required to replace the water filter cartridge at least once per year, and to clean the inlet water screen at least once per year. Consult state/local codes for any additional requirements.

### INSTALLATION OF WATER FILTER

Install new filter by removing sanitary cap from top of cartridge, insure two black O-rings are in place, then lift up into filter head and rotate cartridge 1/4 turn counter clockwise until it comes to a complete stop. Flush 2 gallons (5.6 Liters) of water through the new filter before using proofer to purge air from filter. Remove hose from bottom of proofer by loosening the compression nut at the disconnect fitting and pull hose out. Place hose over container and turn on water. It will take a minute for the filter to fill before water flows out of hose into container. Once filter is flushed with 2 gallons (5.6 Liters) of water, turn off water supply again, insert hose into water line disconnect, tighten compression nut and turn water supply on again. Check for leaks at connection fittings.

### INSTALLATION OF WATER FILTER

1. Install new filter by removing sanitary cap from top of cartridge, insure two black O rings are in place, then lift up into filter head and rotate cartridge 1/4 turn counter clockwise until it comes to a complete stop.
2. Flush 2 gallons (7.5 Liters), of water through the new filter before using proofer to purge air from filter. Remove hose from bottom of proofer by loosening the compression nut at the disconnect fitting and pull hose out. Place hose over container and turn on water. It will take a minute for the filter to fill before water flows out of hose into container.
3. Once filter is flushed with 2 (7.5 Liters), gallons of water, turn off water supply again, insert hose into water line disconnect, tighten compression nut and turn water supply on again. Check for leaks at connection fittings.

**Factory Installed or Kit Backflow Preventer Inlet Water Connection**      **Inlet Water Connection Point**      **Water Connection if Backflow Preventer is Not Required**

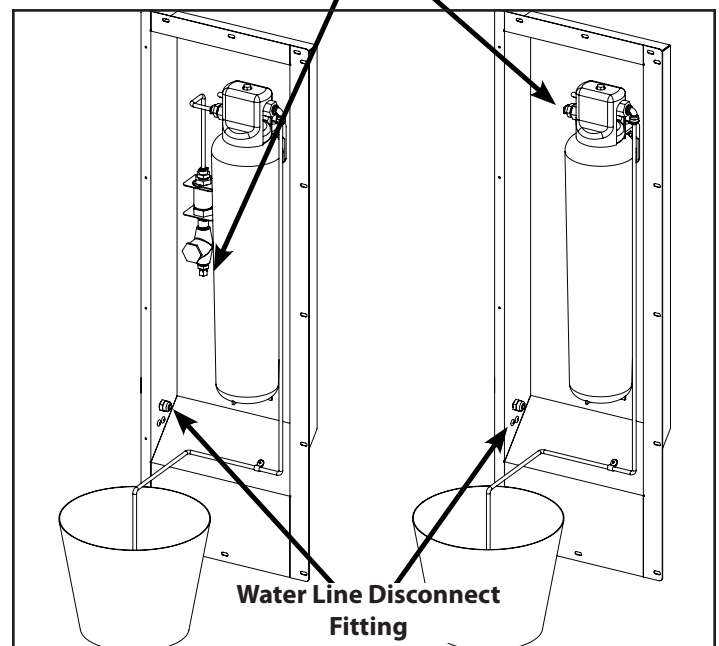

**NOTE: WATER SOURCE REQUIRED FOR PROOFER.**

# INSTALLATION - continued

## INSTALLATION OF WALL-BRACKETS



**NOTE: Verify interconnections and function prior to installing optional wall brackets**

1. Mount the Wall Mounting Brackets with screws provided with the Proofer Oven.
2. Extend the Wall Mounting Bracket towards the wall by sliding it through the slot provided but do not tighten the screws.
3. Mark the Wall and Drill holes for the wall anchors.
4. Insert the wall anchors into the holes.
5. Position the Wall Mounting Brackets against the wall.
6. Insert the screws into the Wall Mounting Bracket.
7. Ensure that the Brackets are firmly against the wall and tighten the screws securely.

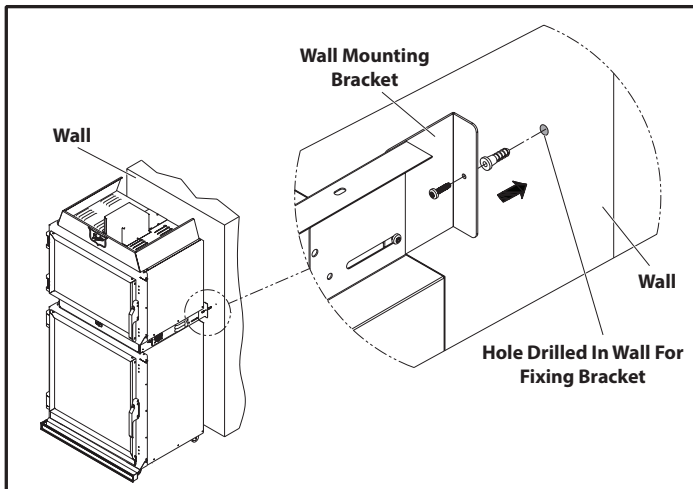



## PROOFER BAKING CENTER START-UP



**ELECTRICAL SHOCK HAZARD.**

**TASKS MUST BE PERFORMED BY A QUALIFIED SERVICE TECHNICIAN OR ELECTRICIAN.**

1. Have a qualified service technician or electrician connect the Proofer Baking Center to the power supply.
2. Turn power on to the unit with the power switch on the left side of the unit. Boot Screen is displayed and automatically transitions to the Main Screen.
3. Turn the oven and proofer ON by touching the  and  buttons located at the left of the touch screen. The Oven, Proofer and Recipe Buttons will turn to BLUE background. The Oven and Proofer lights will turn on and start preheating.
4. Verify Humidification of the proofer. Humidification will begin automatically. Humidity level will be controlled according to user-selected %RH set point.
5. Check the door seals and make sure both doors close completely.
6. If the unit does not power up correctly or if the doors do not close and seal properly, call Duke for assistance.



# CONTROL DEFINITIONS

## MAIN SCREEN

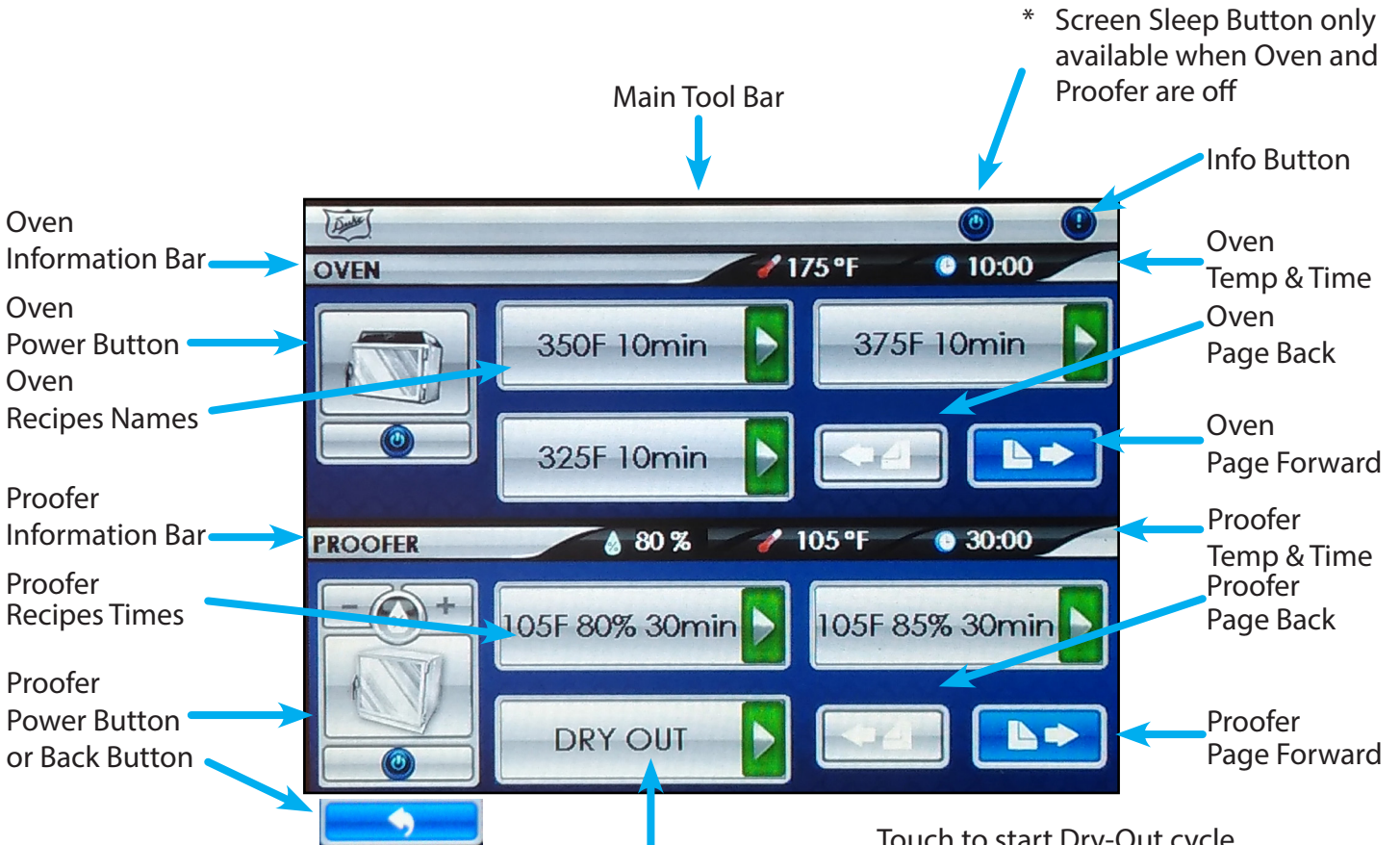

\* Screen Sleep Button only available when Oven and Proofer are off

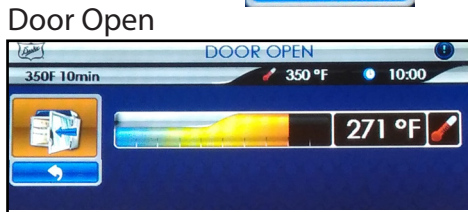

With oven door open, DOOR OPEN will flash in the Main Tool Bar and oven icon background is orange.

Touch to start Dry-Out cycle at end of use for each day.

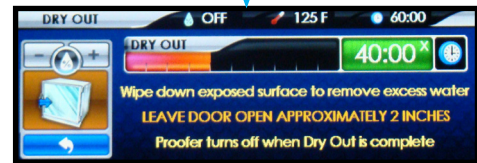

Follow instructions on screen.



## AUDIBLE ALARMS

The Oven/Proofer has various audible alarms.

1 chirp	Keystroke acknowledgment
3 short chirps	Oven and Proofer up-to-temperature notification
4 beeps (Continuous until cleared)	Oven door open alarm
3 long chirps	Proofer stagger load alarm
3 beeps (Continuous until cleared)	Proofer end of cycle
2 beeps (Continuous until cleared)	Oven end of cycle

# OPERATING INSTRUCTIONS

## OVEN/PROOFER START-UP

1. Turn the main power switch located on the left side of the unit "ON". Boot Screen is displayed and automatically transitions to the Main Screen.
2. Turn the Oven and Proofer ON by touching the  and  buttons located at the left of the touch screen. The Oven, Proofer and Recipe Buttons will turn to BLUE background. The Oven and Proofer lights will turn on and start preheating.



3. Check to make sure that the oven and proofer fans are running.
4. Open the oven door; the oven fan should stop.
5. Close the door; the fan should resume.
6. Allow the oven and proofer to pre-heat for at least 30 minutes. An audible alarm will sound (3 short chirps) when the oven and/or proofer reach the ready state. Your Duke Proofer Oven is now ready to operate.



**NOTE:** If there are any problems refer to the Trouble Shooting section of this manual.

## PROOFER OPERATING INSTRUCTIONS

1. Turn the proofer ON by touching the  button or the desired RECIPE button. The Proofer and Recipe Buttons will turn to BLUE background. The Proofer lights will turn on and proofer will start preheating.

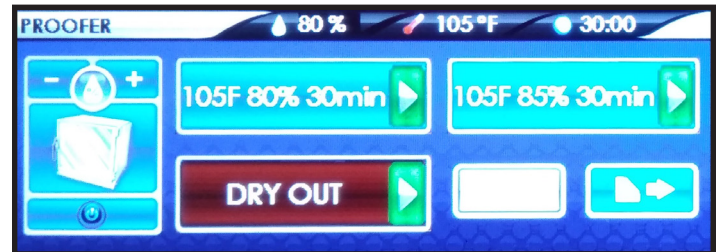

2. Proofer will preheat for 10 minutes after reaching setpoint to ensure proper proofing conditions. An audible alarm will sound (3 short chirps) when the proofer reaches the ready state.

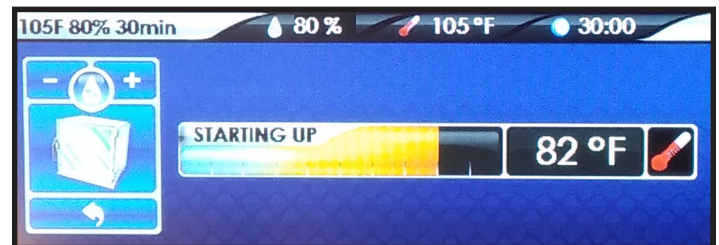

**Proofer Start Up Screen  
(If under temperature set point)**

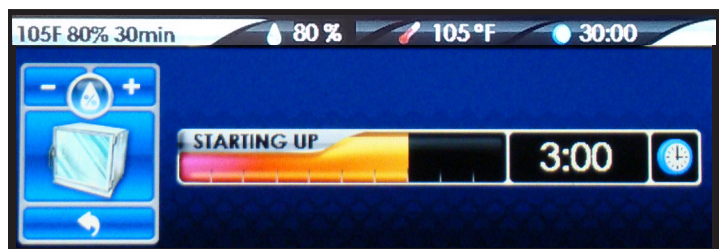



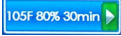

**Proofer Starting Up Screen  
(10 Minute Starting Up Timer)**

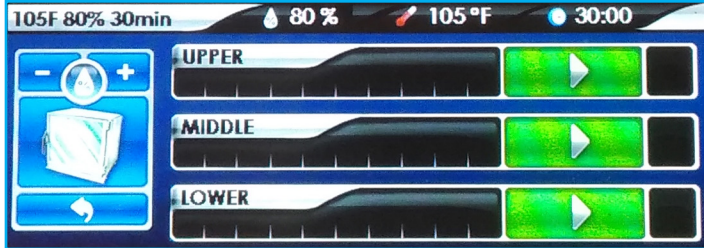
## OPERATING INSTRUCTIONS - continued

- Once a Proofer recipe has been selected (i.e. ) and the display has changed to the Proofer Recipe Ready to start 1/3rd Timers screen, the proofer's humidity should be visually verified before loading.





- Watch for a light fog to appear on the interior door glass; the proofer is ready to be loaded with product.
- Increase humidity, if door glass does not fog as the humidity is set too low; press  button of the  (Relative Humidity). The RH% will increase on the Proofer Recipe Information Bar.
- Decrease humidity if water is running down door glass as the humidity is set too high; press  button of the  (Relative Humidity). The RH% will decrease on the Proofer Recipe Information Bar.

### Is RH% right?



75%RH to 85%RH is usually between fogged glass & droplets running in most ambient environments

- Load the first proofer section with dough and touch UPPER, MIDDLE or LOWER Start Timer , depending on where dough is loaded. This will prevent over-proofing of the dough remaining in proofer after the first load has been moved to the oven. The remaining time will be displayed in the button area and the progress bar will change to visually show elapsed and remaining proof time.

Since the proofer can hold more pans than the oven can bake, an alarm beeps and LOAD NEXT TRAY is displayed in the Main Tool Bar 1/3rd of the time thru the proofer cycle so that loads can be staggered. Load the next proofer section with dough and touch Start Timer  for the respective section.



**NOTE: You can cancel an active timer with touch and hold for 2 to 3 seconds on the count down timer.**

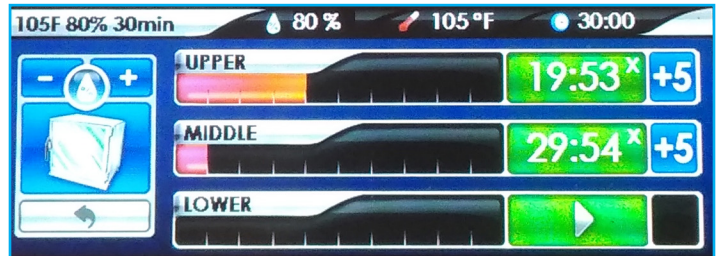

- When the proof is complete, an alarm for the respective timer will beep to alert the operator which level is ready to be moved to the oven. Touch the Timer  to cancel the alarm.

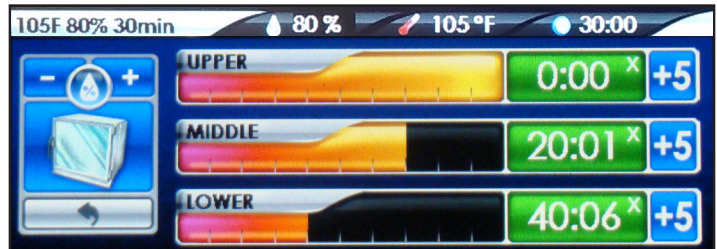

- You can add 5 minutes to proofing time by touching the  button adjacent to any of the respective count down timers. This can be done at any time during the proof or at the end of a proofing cycle. You must add time in 5 minute increments.
- Adjust the time, if necessary, depending on type of dough and desired results.
- Bake bread when dough rises to desired size.





**NOTE: Excessive humidity on the door glass is probably caused by a humidity setting that is too high or by having the humidity on when there is no dough loaded in the proofer.**

# OPERATING INSTRUCTIONS - continued

## OVEN OPERATING INSTRUCTIONS

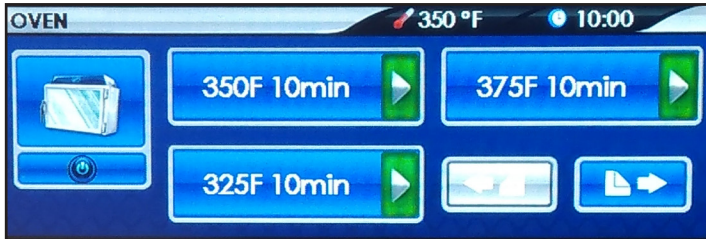
1. Turn the oven ON by touching the  button or the desired RECIPE button. The oven lights will turn on and the Oven will start preheating. An audible alarm will sound (3 short chirps) when the oven reaches the ready state.



2. Allow the oven to preheat 20–30 minutes and keep the oven door closed, except during loading and unloading.
3. Once an Oven recipe has been selected (i.e. ) , the display will change to the Oven Recipe Ready to Start screen (if preheating is complete).

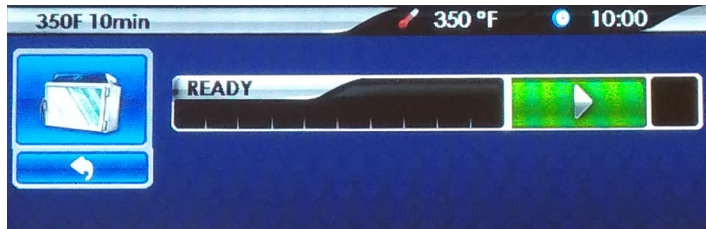
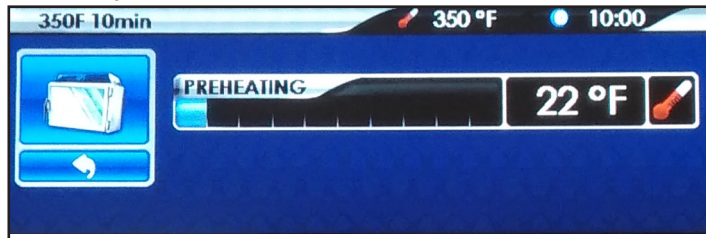

4. Load the oven with dough and touch the start timer  button. The remaining time will be displayed in the button area and the progress bar will change to visually show elapsed and remaining bake time.



**NOTE: You can cancel an active timer with press and hold for 2 to 3 seconds on the count down timer.**

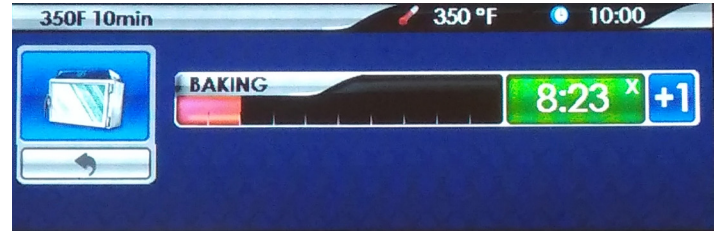

5. When the bake is complete, an alarm will beep to alert the operator. Touch the Timer  or open the oven door to cancel the alarm.

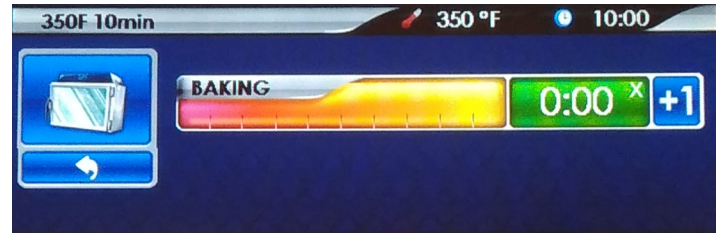

6. You can add 1 minute to baking time by touching the  button adjacent to the count down timer. This can be done at any time during the bake or at the end of a baking cycle. You must add time in 1 minute increments.
7. Adjust the time, if necessary, depending on type of dough and desired results.

## BAKING TIPS

- Always select the oven recipe and allow preheat time prior to loading product. Only load when the Oven Recipe Ready to Start Timers screen is displayed. Load the oven with six pans of dough and touch the start button.
- If the bread color is uneven, reduce temperature and extend bake time in recipe (see Programming Controls).
- If the bread is too dark, reduce the bake time in the recipe (see Programming Controls). If the bake time is reduced and the bread is still too dark, reduce the temperature by 15° F (10° C) and bake longer.
- When baking partial loads, center the pans in the oven and start loading at the bottom shelf and work up to the top.
- Opening oven door allows heat to escape. Under normal conditions, quick loading and unloading will not be a problem. If door is left open too long, oven performance will be affected.



**NOTE: The Proofer Oven has a "Default" run mode. This mode is only active when there is a Touchscreen control communication error and with power to the balance of the controls. This mode allows for your Proofer Oven to maintain approximately 350° F (177° C) in the baking oven and approximately 105° F (41° C) and 80%RH in the proofer. When the Proofer Oven is operating in this mode, you will witness the Proofer and Oven lights blinking off for approximately 2 seconds every minute. This mode allows you to continue using your Proofer Oven for baking and proofing until the unit is properly serviced.**

**The "Default" run mode is disabled with an open oven door.**

# BAKING TIPS

## RECIPE GUIDELINES

"Duke recommends these recipes as starting points for your baking needs"

Product	Proofer Temp	Proofer Humidity	Proofer Time (min)	Bake Temp	Bake Time
Dinner Rolls	105	80%	30-60	350	10-15 min
French Bread	105	85%	30-45	375	35-45 min
Fresh Bread	110	80%	45-90	375	20-25 min
White Bread Loaf	110	85%	90-120	375	20-30 min
Baguette	105	85%	45-60	400	15-30 min
Buns	105	80%	30-45	400	10-12 min
Ciabatta	90	80%	60-90	420	15-25 min
Fresh Croissants	90	80%	60-120	420	15-20 min
Focaccia	90	80%	20-30	420	12-15 min
Frozen Cookies	N/A	N/A	N/A	325	10-12 min
Cup Cakes	N/A	N/A	N/A	350	18-20 min
Sheet Cakes	N/A	N/A	N/A	350	20-30 min
Parbaked Croissants	N/A	N/A	N/A	350	10-15 min
Fresh Cookies	N/A	N/A	N/A	375	8-12 min
Frozen Biscuits	N/A	N/A	N/A	375	20-30 min
Fresh Biscuits	N/A	N/A	N/A	375	12-15 min
Muffins	N/A	N/A	N/A	400	20-25 min





**NOTE:** The Proofer Baking Center was developed for baked good, examples: (cookies, cakes, muffins, croissants, etc.) The Baking Center is Not intended for use with proteins (Examples: bacon, chicken, beef, etc.) Cooking proteins in this unit voids warranty.

## PROGRAMMING CONTROLS

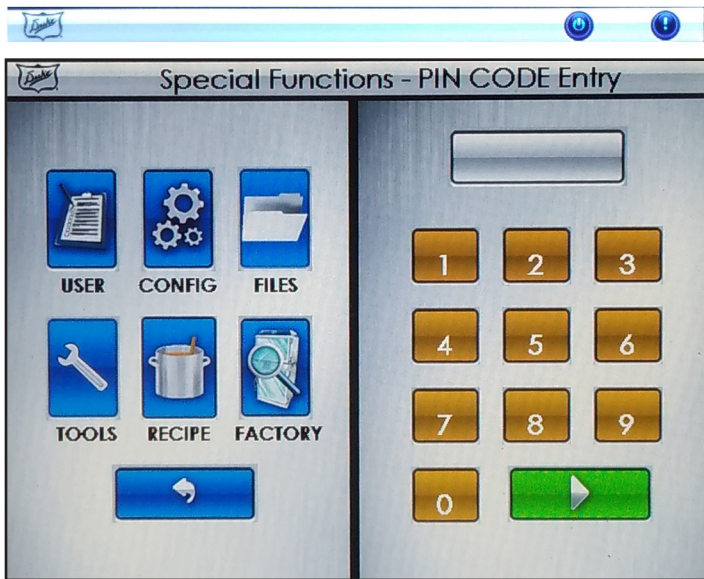
To access the SPECIAL FUNCTIONS, touch  button on the Main Tool Bar.





### RECIPE EDIT PROGRAMMING INSTRUCTIONS

1. Touch the  button and then enter pin code 5 6 7 8 and Touch the  button when prompted.
2. Touch the button for the recipe you want to edit (i.e. ).



**NOTE:** The 6 oven recipes are listed in the top 3 rows and the 6 proofer recipes are listed in the bottom 3 rows. 12 Additional oven recipes are listed on page 2



3. To edit Time, Temperature or Humidity (Proofer Only), touch the  or  button adjacent to the field you want to change. Touch the  button to save the changes.



**NOTE:** You must touch the  button in each field to save the changes you made.









4. To edit the recipe name, touch the  button for the EDIT RECIPE NAME screen.





**NOTE:** Typing will add letters/ characters to the end of the text.

#### PRESS:

-  TO TOGGLE THE KEYBOARD BETWEEN THE UPPER/LOWER CASE CHARACTER SET.
- ,  AND  FOR THE NUMBER AND SYMBOL KEYBOARDS.
-  TO SPACE
-  TO CLEAR ALL TEXT
-  TO DELETE/BACKSPACE

## PROGRAMMING CONTROLS - continued

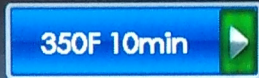





5. Touch the  button to save the changes and return to the RECIPE EDIT Screen. If no changes are required touch the  button to go back to the RECIPE EDIT Screen.



**NOTE: You must touch the  button to save the changes you made.**



6. When complete, touch the  button to go back to the previous screen. Press multiple times to return to the main screen.

### CONFIGURATIONS (CONFIG.)

1. Touch the  button and then enter pin code 2 3 4 5 and Touch the  button when prompted.
2. Touch the button for the setting you want to edit.
  - DATE/TIME – Touching will display DATE/TIME edit screen. Touch the  or  button adjacent to the field you want to change. Touch the  button to save the changes.
  - LANGUAGE – Touching will display a list of included languages. Touch the preferred language button to select.
  - C/F SELECT – Touching will toggle between CENTIGRADE MODE ENABLED and FAHRENHEIT MODE ENABLED.
  - DEFAULT RECIPE – Touching will reload factory defaults.
  - SYSTEM STATUS – Touching will display Proofer Oven status.



### FILES (FILE MANAGEMENT)

1. Touch the  button and then enter pin code 3 4 5 6 and Touch the  button when prompted.
2. Insert USB drive with the file, until seated, into the USB Host Device.

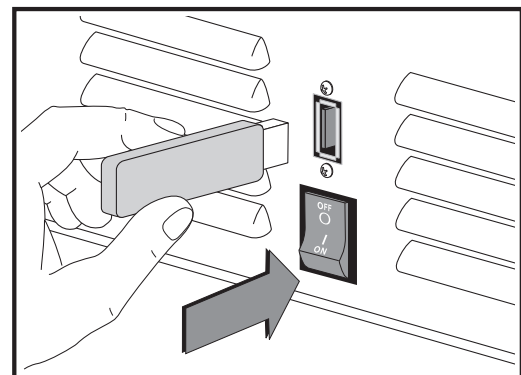

3. Select file operation from list and follow instruction on the display screen.

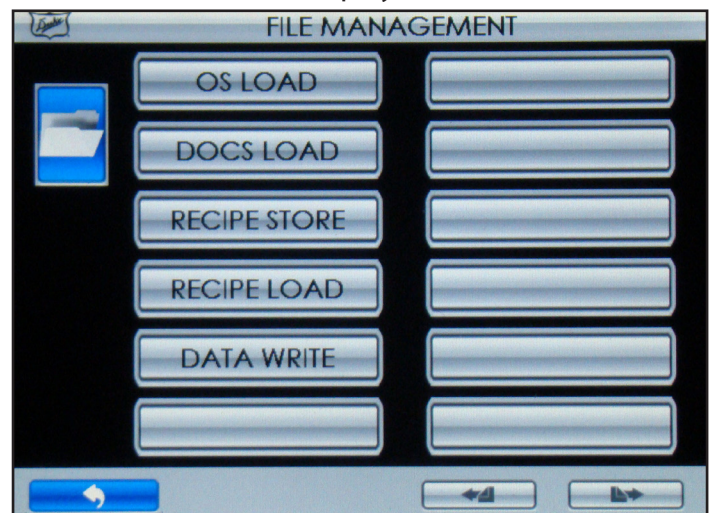

## CARE AND CLEANING



**PROOFER OVEN INTERIOR AND RACKS ARE VERY HOT AND COOL SLOWLY.**

**ALLOW TO COOL BEFORE HANDLING.**



**ELECTRICAL SHOCK HAZARD:**

**DO NOT WASH WITH WATER JET OR HOSE.**



**RISK OF CUT FROM ROTATING FAN BLADE.**

**DISCONNECT POWER TO SERVICE.**





**RISK OF BURN FROM HEATING ELEMENTS.**

**DISCONNECT POWER AND ALLOW TO COOL TO SERVICE.**



**DO NOT USE OVEN CLEANERS, CAUSTIC CLEANERS, DEGREASERS, ACIDS, AMMONIA PRODUCTS, ABRASIVE CLEANERS, STEEL WOOL, OR ABRASIVE PADS CONTAINING IRON. THESE CAN DAMAGE THE STAINLESS STEEL, DOOR GASKETS AND PLASTIC SURFACES.**

### DAILY CLEANING INSTRUCTIONS

1. Empty and clean Drip Pan with clean damp cloth.
  2. Clean stainless steel exterior with stainless steel cleaner or polish, or with hot soapy water followed by a clean water rinse.
  3. Clean oven and proofer doors with a glass cleaner.
  4. Clean oven and proofer interiors with a damp cloth. If heavy soil areas exist clean with hot soapy water and follow with clean damp cloth
  5. Run Dry Out cycle. Touch  on the main screen.
- Follow instructions given on screen after touching . This special function allows automatic water dry out after daily proofer use is completed.
  - Proofer will turn off when DRY OUT is complete.
  - Proofer will turn off when DRY OUT is complete.



**NOTE: DRY OUT is a 60 Minute cycle with extra heat and without water to dry out the Proofer for cleaning.**

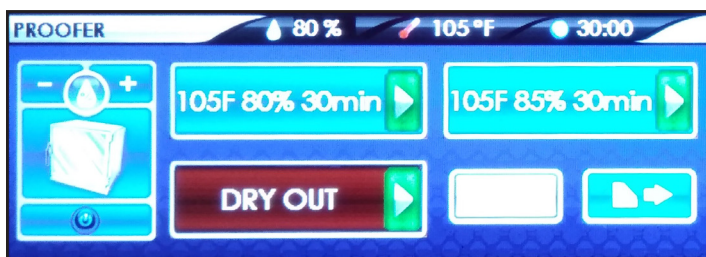

## CARE AND CLEANING

### WEEKLY CLEANING INSTRUCTIONS

1. Clean Proofer. Turn the proofer off and allow elements to cool. Remove the bottom panel (remove screw). Remove excess water by wiping it up with a dry cloth. Clean bottom panel to remove any mineral deposits and debris with hot soapy water and follow with clean damp cloth.
2. Clean Opti-Mist proofer spray Nozzle.
  - A. Remove nozzle assembly by depressing latch on quick-connect fitting and pull nozzle out toward fan blade.
  - B. Soak nozzle in plain white vinegar for 4-8 hours to dissolve mineral deposits. Wipe residue from nozzle and rinse in clean water.
  - C. Do not insert objects into nozzle outlet as this can change the water spray performance.
  - D. Replace nozzle assembly if mineral deposits from hard water cannot be removed.
  - E. Reinstall nozzle by inserting into quick-connect fitting until fully seated.
3. The Cool-Touch door has two window panes. The inner window can be easily separated from the outer window for cleaning. This is achieved by unlatching two clips and rotating the inner window on its hinges. After cleaning, the inner window frame is easily clipped to the outer window by squeezing the two windows together. For additional detail refer to "Cool-Touch Door Information" section of this manual.
4. Inspect oven & proofer door gaskets for cuts, tears or any other damage. Refer to the section on "Door Adjustments and Gasket Maintenance" for directions.

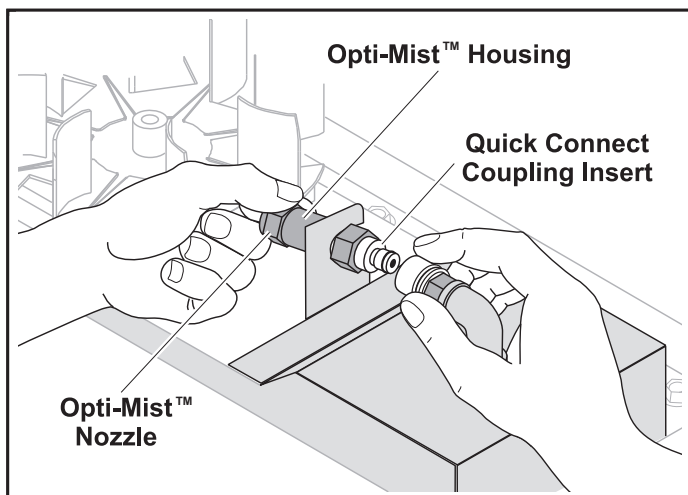

# WIRE DIAGRAM

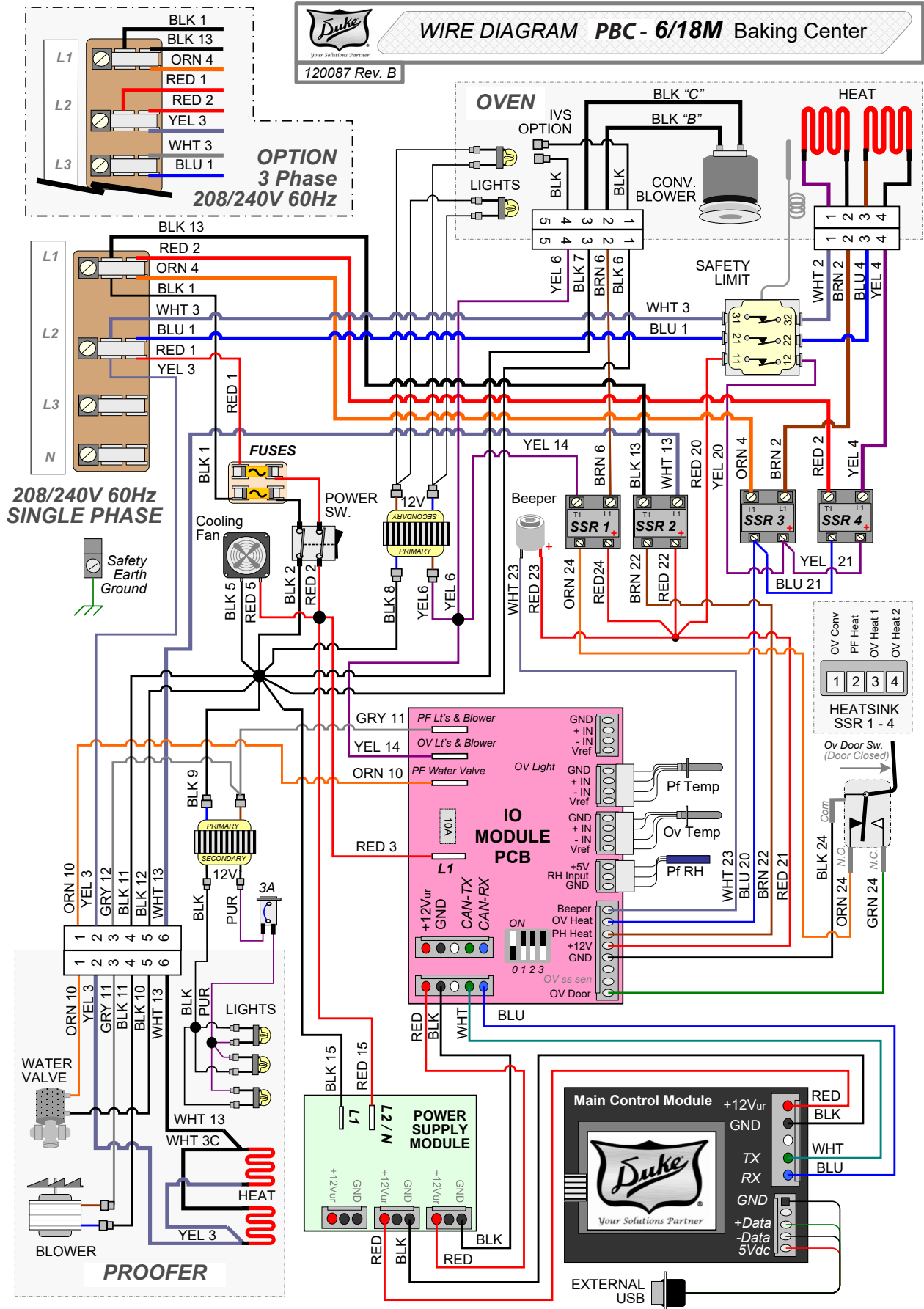

## TROUBLESHOOTING

PROBLEM	YES	NO
<b>1. Oven does not heat with oven switch in the ON position and Oven Temperature not set at 0°.</b>		
a. Are oven indicator lights on?	Observe Oven Fan. Go to "b".	Reset Hi-limit Switch
b. Does Oven Fan work?	Call Duke Service.	Check Proofer Operation. Go to "d".
c. Is Oven Door Securely closed?	Call Duke Service.	Close Door securely. Go to "e".
d. Is Supply Circuit Breaker tripped?	Reset Circuit Breaker. Try oven again. Go to "e"	Check Fuses on Control Box. Go to "e".
e. Does oven work?	Troubleshooting complete.	Call Duke Service.
<b>2. Proofer does not heat with Proofer Switch in the ON position.</b>		
a. Are Proofer indicator lights on?	Observe Proofer Fan. Go to "b".	Check Oven Operation. Go to "c".
c. Does Proofer work?	Call Duke Service.	Check Oven Operation. Go to "c".
c. Does Proofer work?	Call Duke Service.	Check Supply Circuit Breaker. Go to "d".
d. Is Supply Circuit Breaker tripped?	Reset Circuit Breaker. Try Proofer again.	Call Duke Service.
e. Does Proofer work?	Troubleshooting complete.	Call Duke Service.
<b>3. Oven/Proofer lights not working.</b>		
a. Is more than one light not working?	Replace inoperative light bulbs and recheck. Go to "b".	Call Duke Service.
b. Do lights work?	Troubleshooting complete.	Call Duke Service.
<b>4. Proofer Humidity not working/insufficient with Humidity Control not set to Off.</b>		
a. Does there appear to be a light fog on the proofer door?	Decrease humidity if too much moisture on proofer door Go to "b"	Increase humidity if not enough moisture on proofer door. Wait 15 minutes, Go to "b"
b. Does Proofer Fan appear to work?	Go to "c".	Call Duke Service
c. Confirm water supply to unit is on.	Go to "d".	Turn water supply on
d. Check for restrictions in water line. (Kinks in water line, Clogged filter or inlet strainer)	Troubleshooting complete.	Call Duke Service.

A Manually reset high temperature safety limit is provided on the right side of the control section of the unit to protect the oven elements. The high limit will not trip under normal operating conditions. Should the oven high limit trip, push the RESET button. The high limit will reset with a "click" if an over temperature trip occurred. If condition persists, call Duke Service.

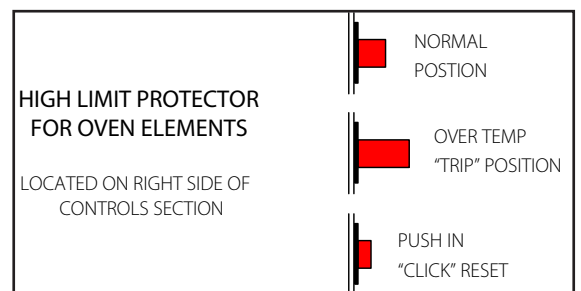

## PREVENTIVE MAINTENANCE

### MONTHLY CLEANING INSTRUCTIONS

1. Check door handle screws for tightness.
2. Check the door gasket seal on the Oven and Proofer for leaks. Refer to the section on "Door Adjustments and Gasket Maintenance" for directions.

### YEARLY CLEANING INSTRUCTIONS

#### 1. Replace water filter cartridge & clean inlet strainer.

- A. Turn off power to Proofer Oven.
- B. Turn off water supply to oven.
- C. Disconnect Wall Brackets if installed. See Installation of wall brackets section of manual.
- D. Remove old filter by rotating cartridge to the left (facing back of cabinet) slowly until pressure starts to release, stop and let pressure and excess water drain through pressure release hose. Once water has stopped draining, continue turning to the left and pull downward.

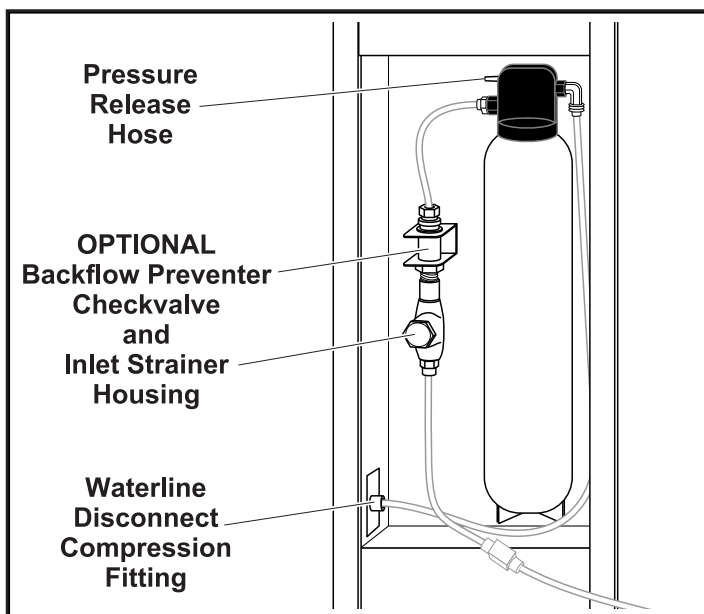

- E. Install new filter by removing sanitary cap from top of cartridge, ensure two black O rings are in place, then lift up into filter head and rotate cartridge 1/4 turn counter clockwise until it comes to a complete stop.
- F. Remove Inlet Strainer by loosening Hex cap on Inlet strainer Housing.
- G. Remove and flush strainer screen with warm water.

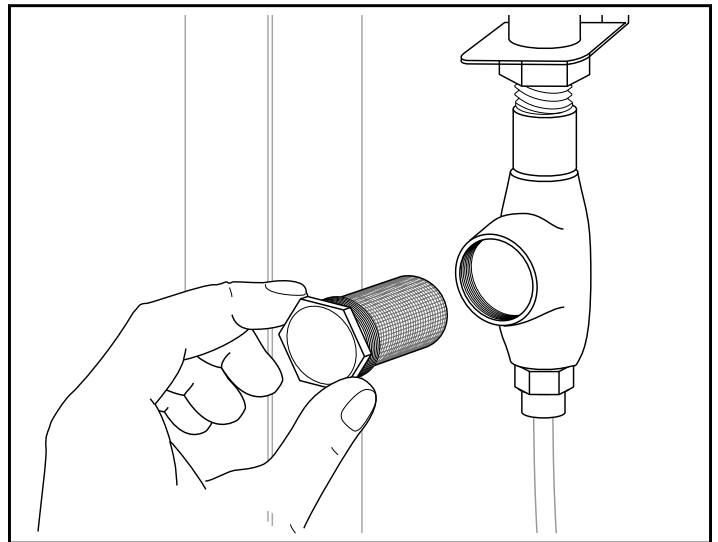

- H. Replace strainer screen and Hex Cap.
- I. Flush 2 gallons of water through the new filter before using proofer to purge air from filter. Remove hose from bottom of proofer by loosening the compression nut at the disconnect fitting and pull tube out. Place tube over container and turn on water. It will take a minute for the filter to fill before water flows out of the tube into the container.
- J. Once filter is flushed with 2 gallons of water, turn off water supply again, insert tube into water line disconnect, tighten compression nut and turn water supply on again. Check for leaks at connection fittings and Inlet Strainer Housing Hex Cap.

## PREVENTIVE MAINTENANCE - continued

Factory Installed or Kit Backflow Preventer Inlet Water Connection  
 Inlet Water Connection Point  
 Water Connection if Backflow Preventer is Not Required

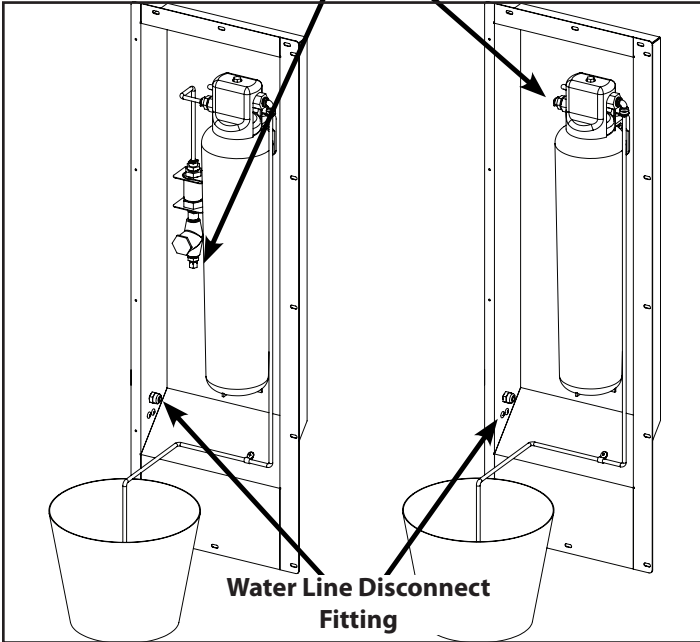

K. Reconnect Wall Brackets if installed. See Installation of Wall Brackets section of Owners manual.

L. Turn on power to Proofer Oven.

**CAUTION:** Replace filter cartridge only with Duke factory-authorized replacement parts to ensure proper operation.

### 2. Clean Opti-Mist™ proofer nozzle screen.

- A. Remove nozzle assembly by depressing latch on quick-connect fitting and pull nozzle out toward fan blade.
- B. Use 3/4" and 5/8" wrenches to remove nozzle from body.
- C. Unscrew filter screen using fingers.
- D. Use 5/32 allen wrench to remove diffuser retainer, diffuser and centering sleeve.
- E. Soak all parts in plain white vinegar for 4-8 hours to dissolve mineral deposits. Wipe residue from nozzle and rinse in clean

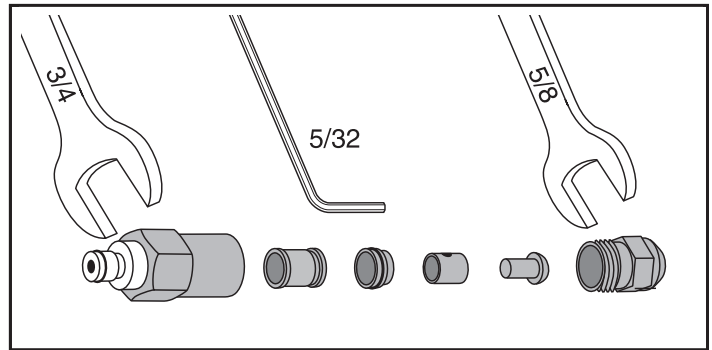

- F. Do not insert objects into nozzle outlet as this can change the water spray performance.
- G. Reassemble nozzle.



**NOTE:** Ensure proper orientation of the Diffuser Retainer.

- H. Replace nozzle assembly if mineral deposits from hard water cannot be removed.
- I. Reinstall nozzle by inserting into quick-connect fitting until fully seated.

## PREVENTIVE MAINTENANCE - continued

### DOOR GASKET LEAK ADJUSTMENTS

The doors should be checked for leaks every three months. The adjustment can be made by following the instructions below. If the door gasket is damaged or compressed permanently, it should be replaced. Call Duke Manufacturing Co. at 800-735-3853 to order a new gasket before making adjustments.

1. To check the adjustment, close the door with a currency bill between the gasket and front of the oven. Resistance should be felt when pulling the currency bill out with the door closed. Do this check in several places and readjust the door as necessary.

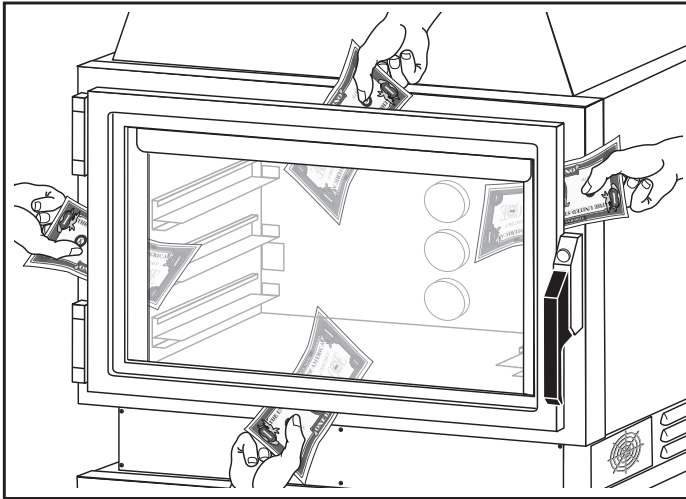

2. With the door closed, remove the hinge covers with a screwdriver and loosen the six screws that hold the hinges to the door.

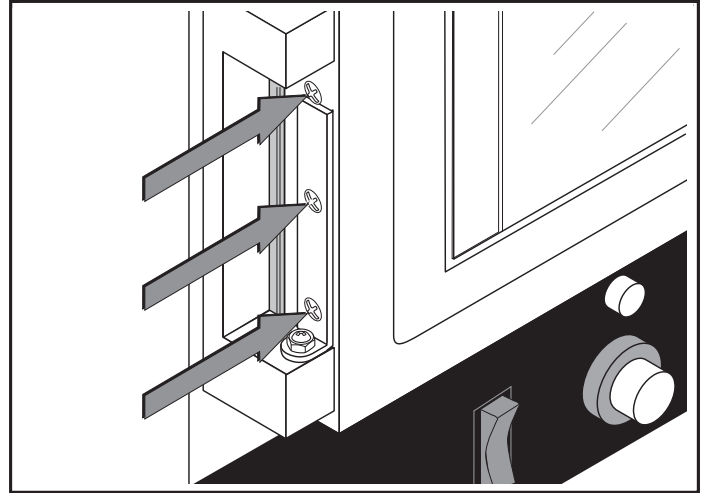
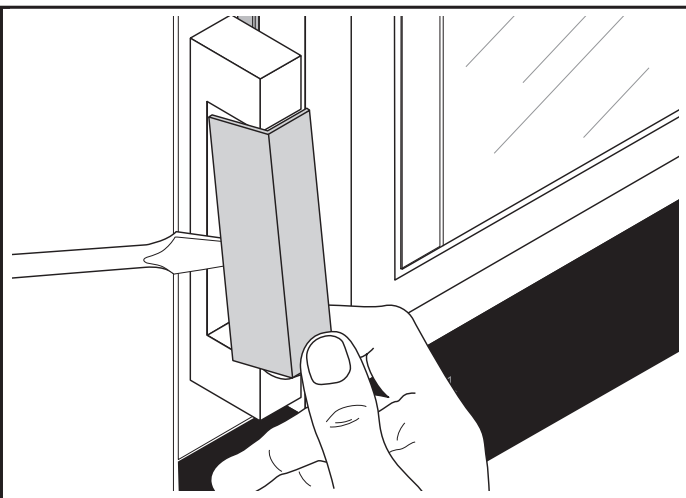

3. Adjust the door position by moving the door frame in or out to seal any gaps between the gasket and the oven. Adjustment is made using the screws on the handle and the hinges.

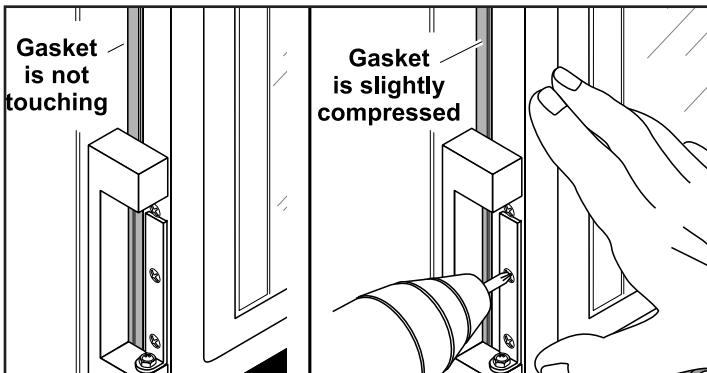
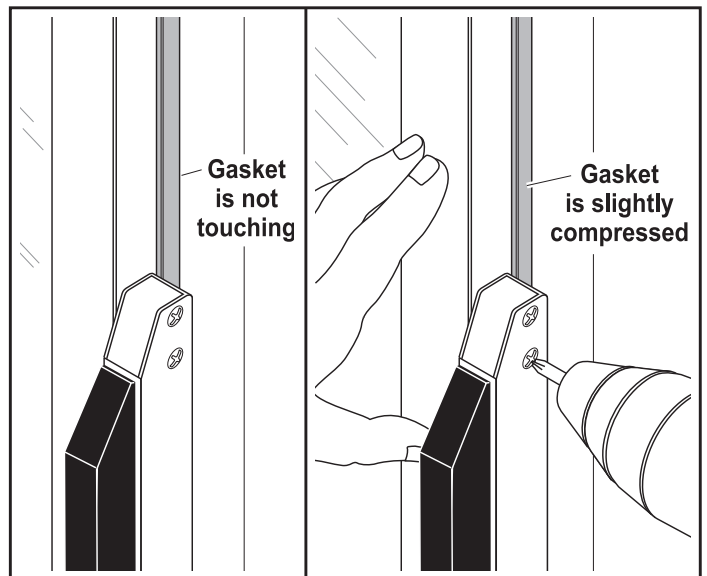

#### IMPORTANT

Be careful not to compress the gasket too much, or it will not allow the door to be closed.

## PREVENTIVE MAINTENANCE - continued

4. To check the adjustment, close the door with a currency bill between the gasket and front of the oven. Resistance should be felt when pulling the currency bill out with the door closed. Do this check in several places and readjust the door if necessary.

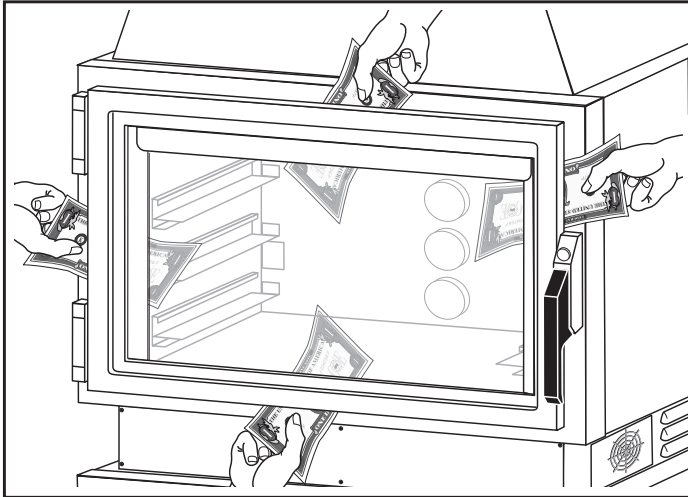

2. Clean the groove with a screwdriver or other flat-bladed tool to remove any dirt or gasket pieces.

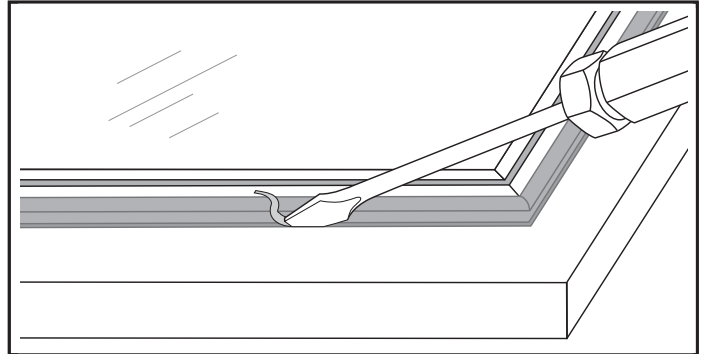

3. Press the new gasket into the groove. Make sure it is fully seated in the groove and flat against the door frame.

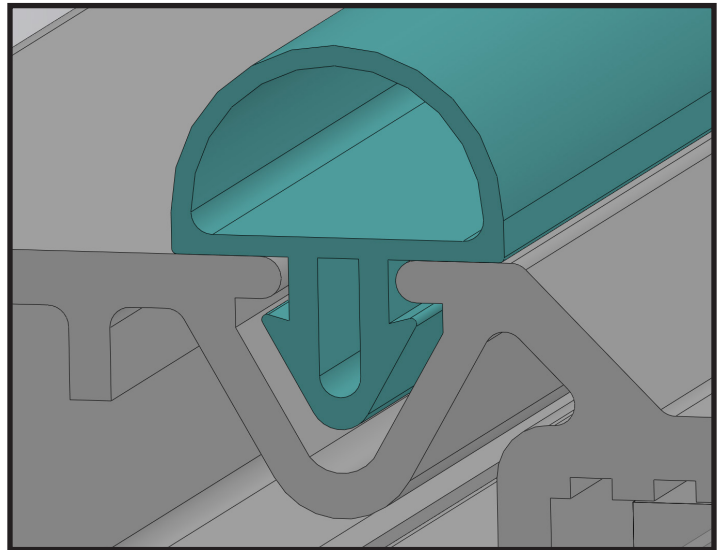

## GASKET REPLACEMENT

1. Remove the old gasket by pulling it out of the groove in the door frame.

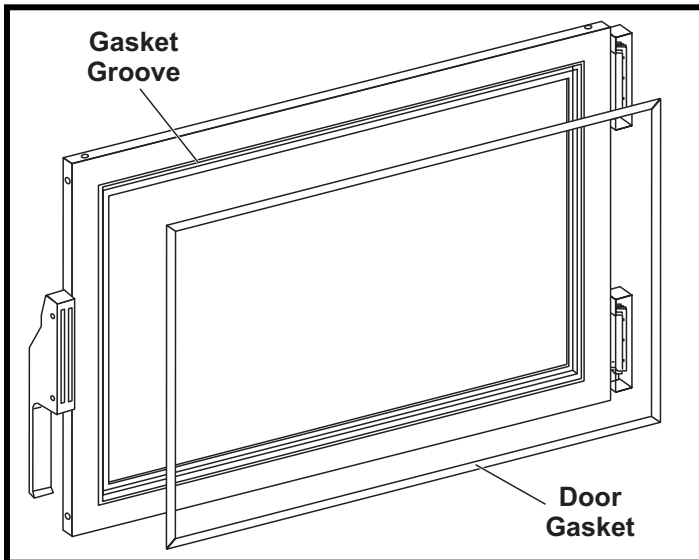



## NOTES

## PREVENTIVE MAINTENANCE

### COOL-TOUCH DOOR INFORMATION AND CLEANING INSTRUCTIONS

The Cool-Touch door has two window panes. The inner window can be easily separated from the outer window for cleaning. This is achieved by unlatching two clips and rotating the inner window on its hinges. After cleaning, the inner window frame is easily clipped to the outer window by squeezing the two windows together.

1. To open the windows for cleaning, unlatch the top and bottom clips. Cool-Touch Door bottom easily swings open for cleaning.

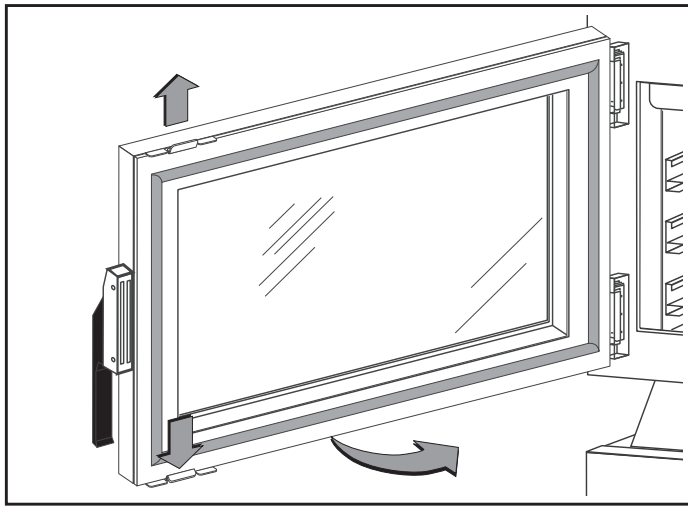

2. Cool-Touch inner door is easily clipped to the outer door by squeezing them together.

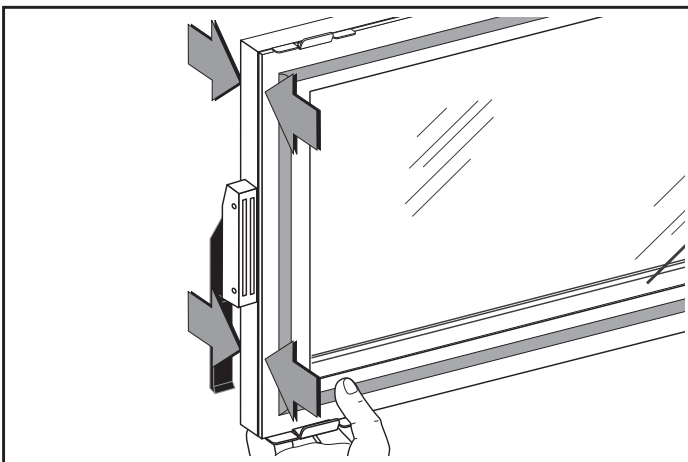

### BULB MOUNTING DETAILS



**DO NOT TOUCH LIGHT BULBS WITH BARE HANDS AS OIL/FINGERPRINTS WILL SHORTEN THE LIFE OF THE BULB. USE A CLEAN GLOVE OR CLOTH TO HANDLE BULBS.**

1. Turn the Proofer Oven OFF and allow to cool.
2. Remove the light lens and gasket by turning it counter clockwise.
3. Remove the burned out bulb.
4. Using clean gloves or a cloth, install the new lamp bulb (Halogen Lamp G4, 12 Volts, 10 Watt Maximum) into the lamp holder.
5. Replace light lens and gasket ensuring it is fully seated and tightened or leaks will occur.

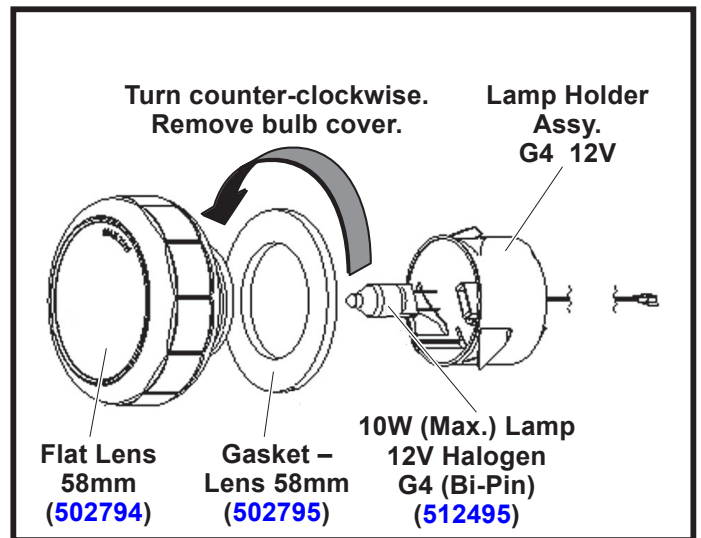



Your Solutions Partner

**Duke Manufacturing Co.**

2305 N. Broadway  
St. Louis, MO 63102

Phone: 314-231-1130  
Toll Free: 1-800-735-3853  
Fax: 314-231-5074

[www.dukemfg.com](http://www.dukemfg.com)