

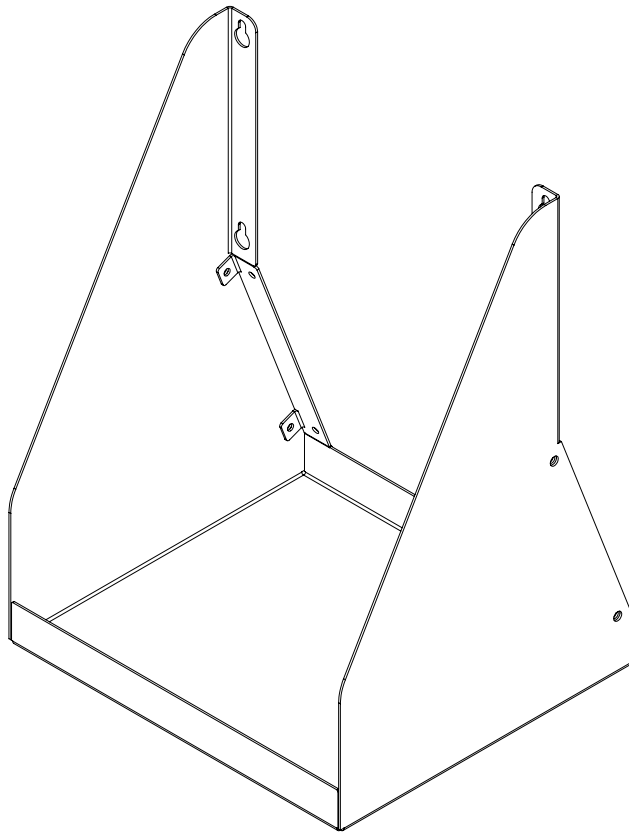

Your Solutions Partner

## Receipt Shelf

# Instruction Sheet



Tool Needed



#2 Phillips Screwdriver

**CAUTION:** Please read these instructions completely before attempting to install, operate or service this equipment.

 **WARNING for CA residents: go to [www.dukemfg.com/prop65](http://www.dukemfg.com/prop65) for prop 65 warning**

*This manual is Copyright © 2022 Duke Manufacturing Co. All rights reserved.  
Reproduction without written permission is prohibited. Duke is a registered  
trademark of the Duke Manufacturing Co.*

**P/N 529049  
REV A 08/24/2022**

# INSTRUCTIONS

## Step 1

Locate the control panel on the hot food unit and begin loosening the four outer screws so there is approximately 1/8" gap between the head of the screw and the control panel.

**Do NOT completely loosen/remove the screws from the front panel.**

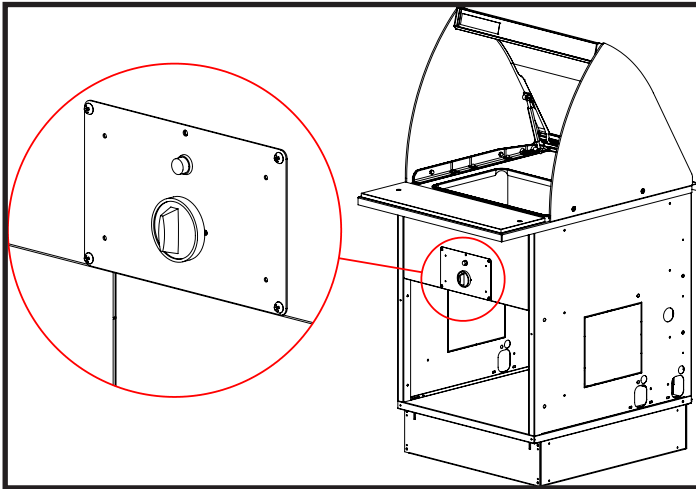

## Step 2

Slide the receipt shelf over the head of the screws from step one then slide it down so the slots on the shelf are resting against the shaft of the screw and the head of the screw is capturing the flange.

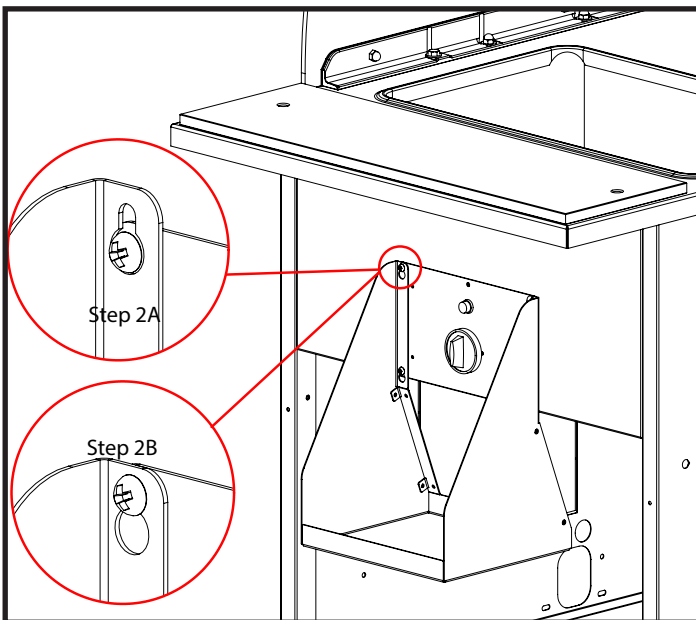

## Step 3

Once the shelf is in place tighten the four screws from step one so that everything is secure.

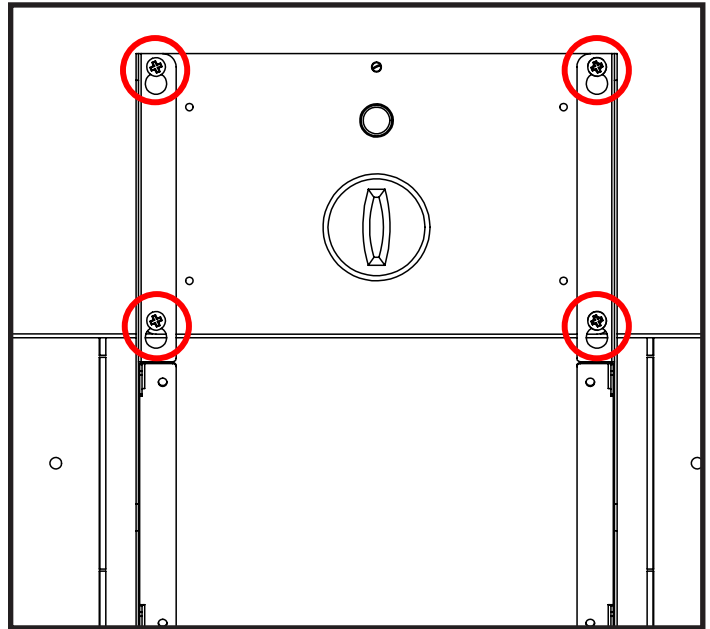

## Step 4

Installation complete. You are now ready to install your receipt printer.



Your Solutions Partner

**Duke Manufacturing Co.**

2305 N. Broadway  
St. Louis, MO 63102

Phone: 314-231-1130

Toll Free: 1-800-735-3853

Fax: 314-231-5074

[www.dukemfg.com](http://www.dukemfg.com)