



Your Solutions Partner

Installation and Operation Manual

Hot Food Warmer

Models:

SUB-HF-16.5

SUB-HF-18

SUB-HF-19

SUB-HF-21

SUB-HF-25

SUB-HF-31

SUB-HF-37

SUB-HF-49

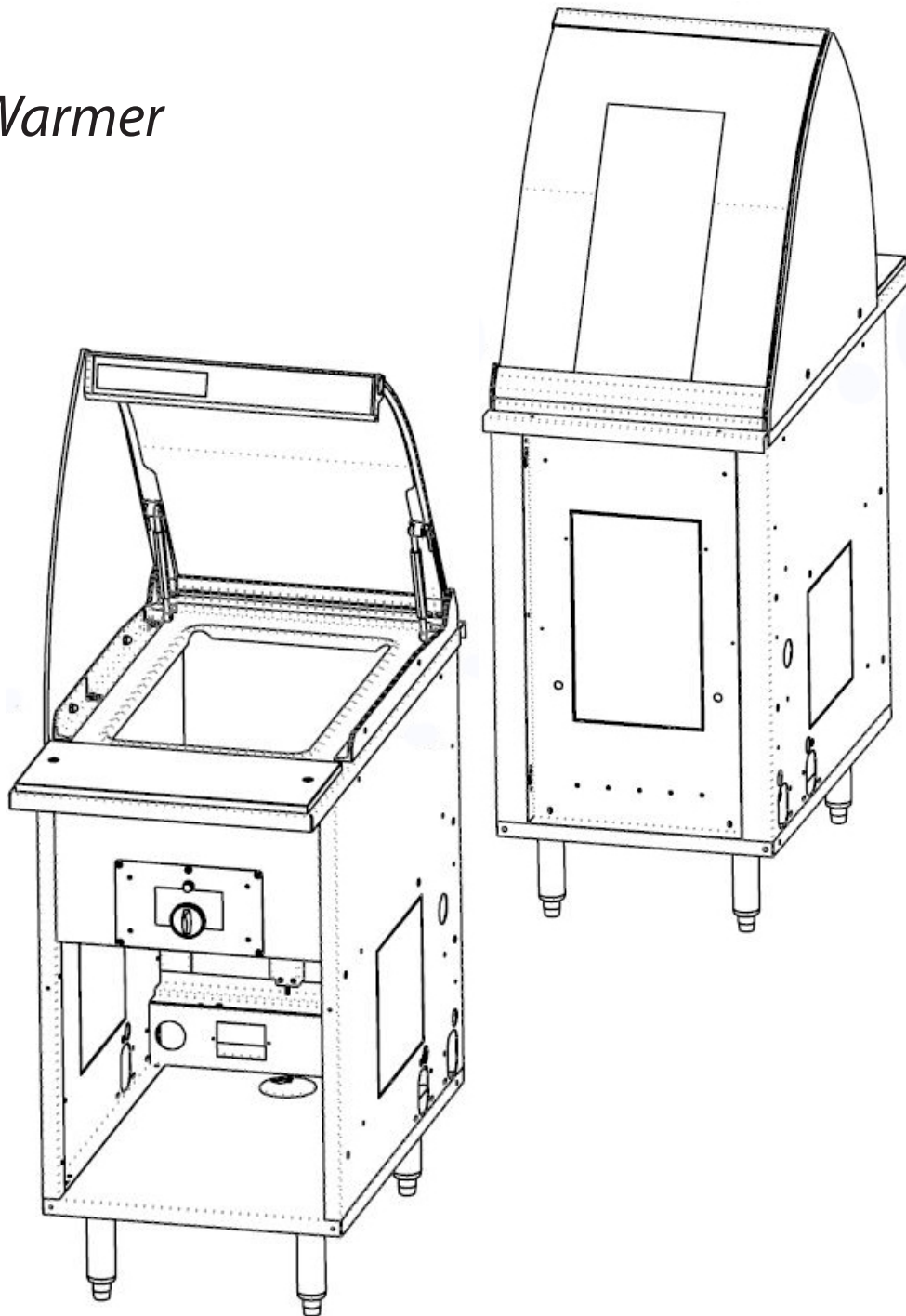

CAUTION: Please read this manual completely before attempting to install, operate or service this equipment

*This manual is Copyright © 2019 Duke Manufacturing Co. All rights reserved.
Reproduction without written permission is prohibited. Duke is a registered
trademark of the Duke Manufacturing Co.*

**P/N 529113
REV D 08/04/2020**

TABLE OF CONTENTS

Important Safety Instructions..... 2

Tools and Parts..... 5

Inspection 6

Installation of Hot Food Warmer

 I. Unit Placement and adjustment..... 7

 II. Installation and adjustment of end glass (adjacent units)..... 8

 III. Installation and adjustment of end glass (end of line) 9

 IV. Adjusting Front Glass 10

Operations Instructions

 I. General Instructions 11

 II. Operating Instructions 11

 III Operating Checklist and Cleaning Guide 12

 IV Troubleshooting..... 12

 V. Unit Line Up and Electrical Information 13

Wire Diagrams

 120V 14

 220V 15

IMPORTANT SAFETY INSTRUCTIONS

Throughout this manual, you will find the following safety words and symbols that signify important safety issues with regards to operating or maintaining the equipment.



Indicates a hazardous situation which, if not avoided, could result in death or serious injury.



Indicates a hazardous situation which, if not avoided, could result in minor or moderate injury.



Indicates Important Information



Indicates electrical shock hazard which, if not avoided, could result in death or serious injury and/or equipment damage.



Indicates hot surface which, if not avoided, could result in minor or moderate injury.



Electrical shock hazard. Do not wash with water jet or hose.

In addition to the warnings and cautions in this manual, use the following guidelines for safe operation of the unit.

- Read all instructions before using equipment.
- For your safety, the equipment is furnished with a properly grounded cord connector. Do not attempt to remove or disconnect the grounded connector.
- Install or locate the equipment only for its intended use as described in this manual.
- Do not use corrosive chemicals in this equipment.
- Do not use caustic cleaners, acids, ammonia products or abrasive cleaners or abrasive cloths. These can damage the stainless steel and plastic surfaces.
- Do not operate this equipment if it has a damaged cord or plug, if it is not working properly, or if it has been damaged or dropped.
- This equipment shall be serviced by qualified personnel only. Contact the nearest Duke authorized service facility for adjustment or repair.
- Do not block or cover any openings on the unit.
- Do not immerse cord or plug in water.
- Keep cord away from heated surfaces.
- Do not allow cord to hang over edge of table or counter.
- If the supply cord is damaged, it must be replaced by a special cord assembly available from Duke Manufacturing Co. or its service agent.

Note: Refer to the specifications data plate when ordering or replacing a cord set.

The following warnings and cautions appear throughout this manual and shall be carefully observed.

- Turn the unit off, disconnect the power source and allow unit to cool down before performing any service or maintenance on the unit.
- The procedures in this manual may include the use of chemical products. You must read the Material Safety Data Sheets before using any of these products.
- The unit shall be grounded according to local electrical codes to prevent the possibility of electrical shock. It requires a grounded receptacle with dedicated electrical lines, protected by fuses or circuit breaker of the proper rating, in accordance with all applicable regulations.
- Disposal of the unit must be in accordance with local environmental codes and/or any other applicable codes.
- This appliance is not intended for use by persons (including children) with reduced physical, sensory or mental capabilities, or lack of experience and knowledge, unless they have been given supervision or instruction concerning use of the appliance by a person responsible for their safety.
- CAUTION: Never use a high-pressure water wash for this cleaning procedure as water can damage electrical components



**ELECTRICAL SHOCK HAZARD UNIT MUST BE SAFETY GROUNDED, EARTHED.
DO NOT MODIFY, DEFEAT ELECTRICAL CONNECTIONS OR ALTER PLUG.**

ELECTRICAL CONNECTIONS

⚠ WARNING BEFORE CONNECTING THE UNIT TO THE POWER SOURCE, VERIFY THAT THE VOLTAGE AND PHASE OF THE POWER SOURCE ARE IDENTICAL TO THE VOLTAGE AND PHASE INFORMATION ON THE DATA LABEL.

EARTHING INSTRUCTIONS

1. THE UNIT MUST BE GROUNDED. Grounding reduces risk of electric shock by providing an escape wire for the electric current if an electrical short occurs. This unit is equipped with a cord having a grounding wire with a grounding plug. The plug must be plugged into a receptacle that is properly installed and grounded.
2. Consult a qualified electrician or service agent if grounding instructions are not completely understood, or if doubt exists as to whether the unit is properly grounded.
3. DO NOT USE AN EXTENSION CORD. If the product power cord is too short, have a qualified electrician install a three-slot receptacle (or the country specific receptacle for International Units). This unit should be plugged into a dedicated circuit with the electrical rating as provided on the product data plate.

EXTERNAL EQUIPOTENTIAL BONDING TERMINAL (EXPORT ONLY)

1. This equipment has supplemental bonding terminal. The terminal provides an external bonding connection used in addition to the earthing prong on the plug. The terminal provides a connection for bonding to the equipment enclosure. The external equipotential bonding terminal located on the rear outside surface of the unit, the terminal is marked with the symbol to the right.



INSTALLATION CODES AND STANDARDS

In the United States, the Unit must be installed in accordance with the following:

1. State and local codes.
2. National Electrical Code (ANSI/NFPA No. 70, latest edition) available from the National Fire Protection Association, Batterymarch Park, Quincy, MA 02269.
3. Vapor Removal from Cooking Equipment, (NFPA-96, latest edition) available from NFPA.
4. Sealed to the counter upon which the equipment is placed per NSF/ANSI 4 standard.

In Canada, the Unit must be installed in accordance with the following:

1. Local codes.
2. Canadian Electrical Code (CSA C22.2 No. 3, latest edition) available from the Canadian Standards Association, 5060 Spectrum Way, Mississauga, Ontario, Canada L4W 5N6.

“For CE Units, the Unit must be installed in accordance with the following:

1. Local codes.
2. European (IEC/CENELEC) Electrical Code

Tools and Parts Needed for Installation

Tools Needed - not included



Phillips Screw Driver



7/16" Wrench



Cordless Drill



Caulk Gun/
Silicone



Socket set with
5/16 socket



Adjustable
Pliers



13mm Wrench



3/32 Allen
Wrench

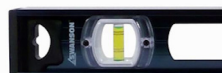

Level



Wire Cutters
-Strippers

Parts and Hardware Included

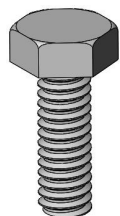

223424 Hex
Head Bolt
10-24X1/2" 4ea.

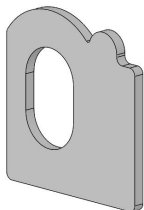

2501061
Stainless
Washer 4ea.



523030 Bolt
1/4-20 X 1"
2ea.



223108 Bolt
1/4-20X3/4"
2ea.



223398
Plastic
Washer 4ea.

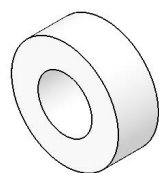

524100
Plastic Spacer
4ea.

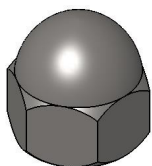

223390
1/4-20
Cap Nut 4ea.

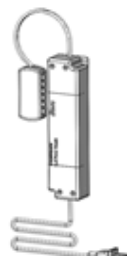

524414 (120V)
524417 (240V)
Power Supply



226115
End Glass 1ea.



225035 Gaskets 2ea.



216576
Silicone Sealant



2501693 Plastic
Wrench 1ea.

Inspection

UNPACKING UNIT

- Inspect the shipping carton and/or container, carefully noting any exterior damage on the delivery receipt
- Note any damage not evident on the outside of the shipping container (concealed damage). Contact the carrier immediately and file a damage claim with them.
- Save all packing materials when filing a claim. Freight damage claims are the responsibility of the purchaser and are not covered by the warranty.
- Report any dents or breakage to source of purchase immediately.
- **Do not attempt to use unit if damaged.**
- Remove all materials from unit interior.
- Remove unit from Skid
- If unit has been stored in extremely cold area, wait a few hours before connecting power.



Installation - Hot Food Warmer

I. Unit Placement and Adjustment

Step 1

Line up unit with front counter. Unit to be installed between bread display and cold pan unit.

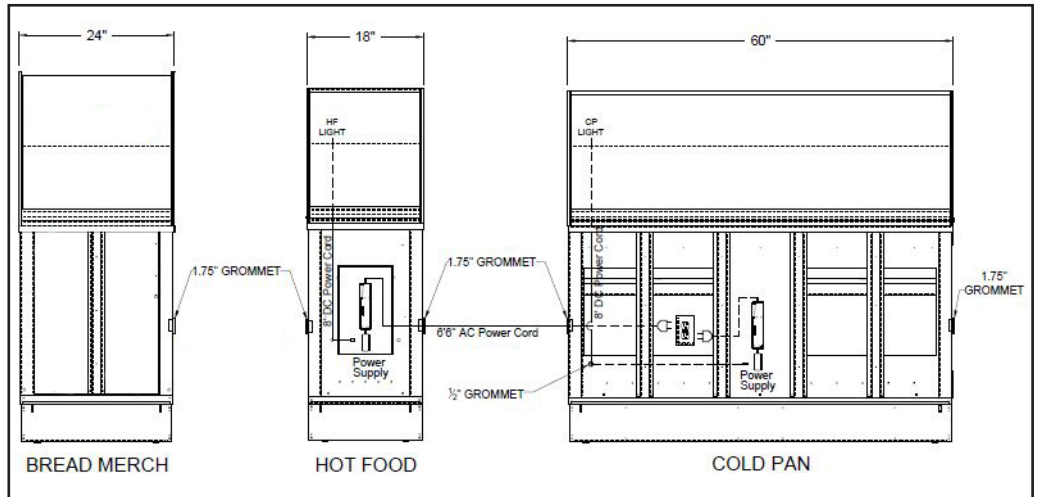

Step 2

Make sure unit is level with cold pan unit.

NOTE: Make sure cold pan unit is level first. When installing full line up make sure all units are level with cold pan.

CAUTION

Failure to complete this step could result in Decor Panels not lining up.



Step 3

Adjustment can be made by turning the legs using adjustable pliers.

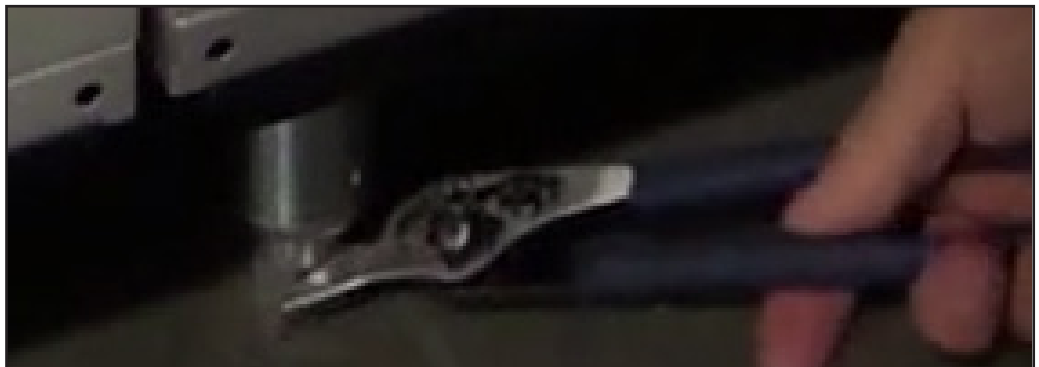

Installation - Hot Food Warmer - continued

II. INSTALLATION AND ADJUSTMENT OF END GLASS (adjacent units)

NOTE: When two cold pans are installed side-by-side, the day covers should be bolted together with only ONE end glass pane in between.

TOOLS REQUIRED: Phillips screw driver, 3/32 allen wrench, 7/16 wrench



1. After two base units are bolted together and leveled, place **PLASTIC SPACER** in **END GLASS** and install **END GLASS** between two **GASKETS** and **MOUNTING ANGLES**. Align the mounting holes.

Note: Glass must be bolted tight without gaps and centered between the two day covers. Loosen Hex bolts if needed.

2. Use **1/4-20 x 1" BOLT** and **1/4-20 CAP NUT** provided in kit to fasten end glass to the angle (2 places).

NOTE: Loosen HEX HEAD BOLTS if needed fastening angle to the top of the unit, to allow for adjustment.

3. Tighten 4 hex bolts (2) on each side.

4. Apply a bead of silicone on bottom of stainless steel washers.

5. Apply a bead of clear silicone along bottom edge of the day cover as shown in diagram at right.



6. Repeat steps 1 through 6 for all adjacent units of the lineup.

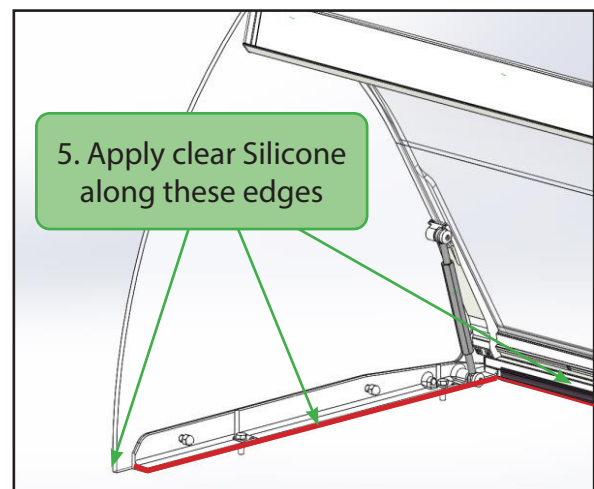
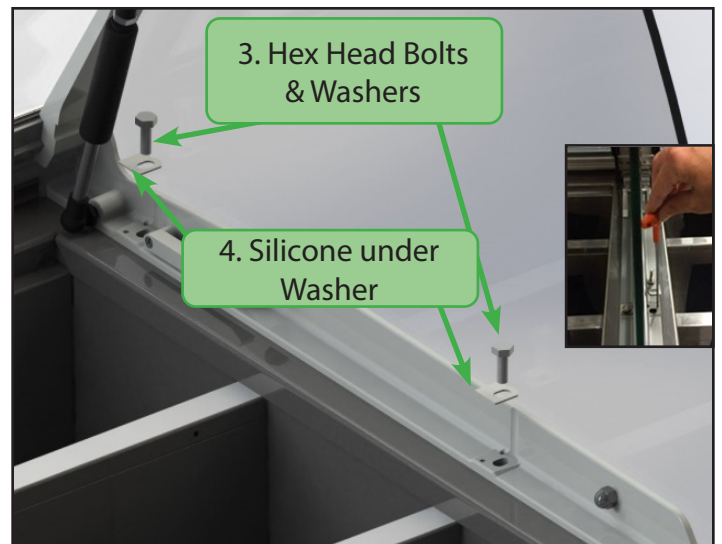
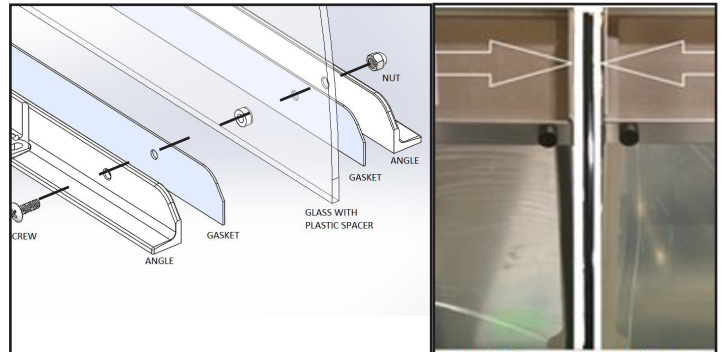

Installation - Hot Food Warmer - continued

III. INSTALLATION AND ADJUSTMENT OF END GLASS (end of lineup)

TOOLS REQUIRED: Phillips screw driver, 3/32 allen wrench, 7/16 wrench

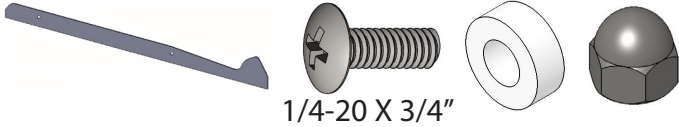

1. After the base units are installed and leveled, place **PLASTIC SPACER** in **END GLASS** on the outside of the **GASKET** and **MOUNTING ANGLE** and align the holes.
2. Use **1/4-20 x 3/4" BOLT** and **1/4-20 CAP NUT** provided in kit to fasten end glass to the angle (2 places).

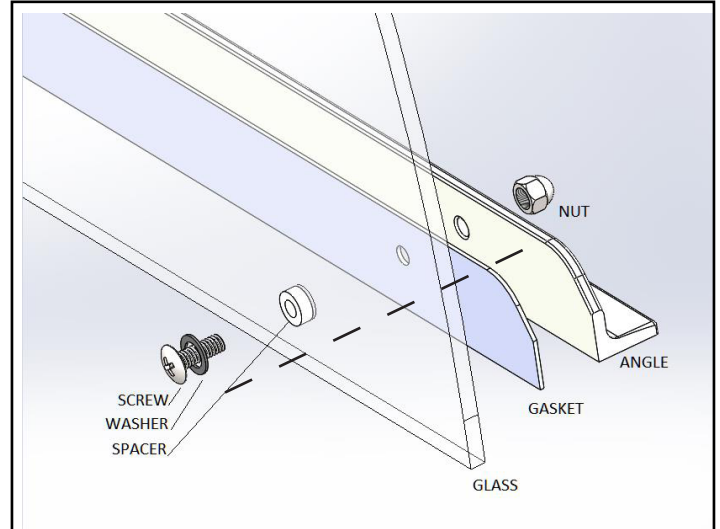

NOTE: Loosen HEX HEAD BOLTS if needed fastening angle to the top of the unit, to allow for adjustment.

3. Tighten 4 hex bolts (2) on each side.
4. Apply a bead of silicone on bottom of stainless steel washers.



5. Apply a bead of clear silicone along bottom edge of the day cover as shown in diagram at right.

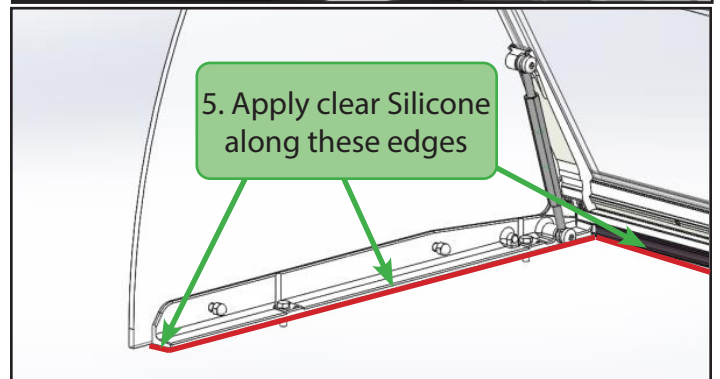
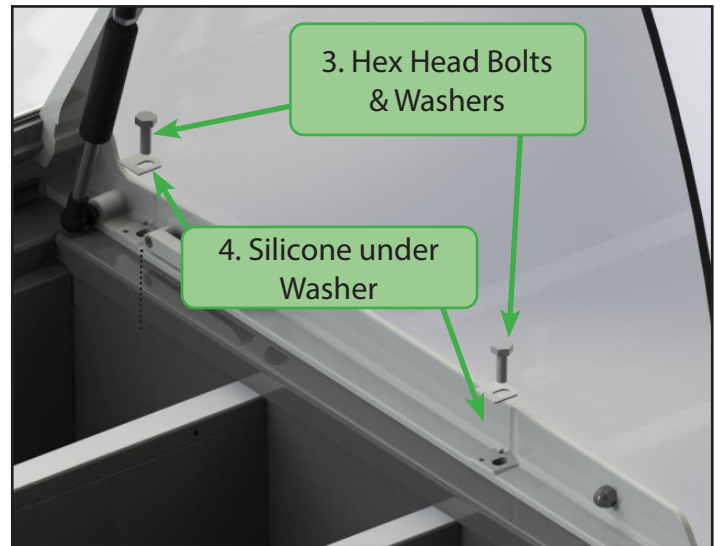

Installation - Hot Food Warmer - continued

IV. Adjusting Front Glass

TOOLS REQUIRED: Adjustable pliers, 13mm wrench

a.) FIXED DAY COVER - Turnbuckle

1. If present, start alignment with a **FIXED** day cover. If necessary, rotate the turnbuckle left or right to achieve proper angular position of glass.

CAUTION Do not to scratch paint (use the plastic wrench included in kit).



NOTE: Use end glass as a guide for adjusting front glass. When adjusted correctly, the curve of the front glass is parallel to the edge of the end glass, at approximately 60° to top

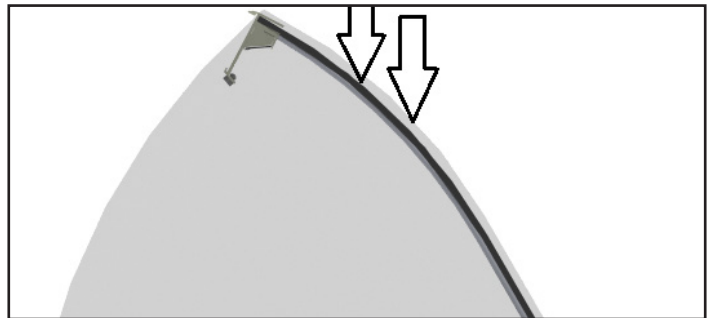
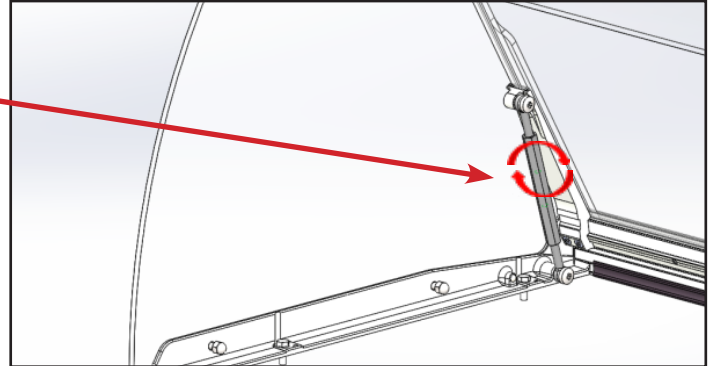

Operation Instructions

I. General Instructions

1. All food service equipment should be operated by trained personnel.
2. Do not allow your customers to come in contact with any surface labeled **"CAUTION HOT"**.
3. Do not cook, warm or hold food directly in wells.
4. Never hold food below 150°F.
5. Always place covers on pans when not serving to prevent food from drying out and to reduce your operating costs.
6. For most efficient operation, keep empty, covered pans in each pan location during preheating and when a pan location is not in use.

CAUTION To comply with sanitation requirements, do not set the temperature control to hold product lower than 155o F.

1. The most satisfactory control settings must be determined by experience based on the nature of the food service and the type of operation as well as individual preference of the restaurant operator. The proper control setting necessary to keep foods at the desired temperature will vary dependent upon the frequency of turnover, size of food containers, amount of food in each container, room temperature, location of holding unit with respect to range or other heated equipment, air outlets, fans, doors and passageways.

II. Operating Instructions

1. Place spillage pan in unit and fill with 1 to 1 1/2" of hot water. Then cover the well with lid.
Note: If this is a sealed well unit, put water directly into the sealed well.
2. Turn the Knob(s) to the HIGH position.
3. Allow the Channels to heat for at least 20 min. Then set temperature control to desired holding setting.
4. Place fully warmed food into pans and place in preheated unit. This unit is not designed to reheat cold food product.
5. At end of day, remove all food pans and lids and turn off main power switch.
6. Let unit cool and clean per cleaning instructions.

Operation Instructions - Continued

III. Operation Checklist and Cleaning Guide

DAILY

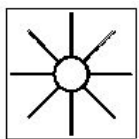

Opening Checklist

1. Place spillage pan in unit and fill with 1 - 1 1/2" of hot water. Then cover the well with lid.
2. Turn the Knob(s) to the High position.
3. Allow the Product Holding Cabinet to heat for at least 20 min.

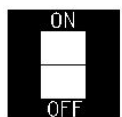

Operation Instructions/Adjustments

1. Indicator light will be lit while control is in the ON position.

Closing Checklist



1. Turn the Knob(s) to the OFF position.
2. Remove all pans and pan covers.
3. Allow unit to cool for approximately 30 minutes.
4. Clean well as outlined in the Cleaning Instructions.

Cleaning Instructions

1. Turn unit off and allow unit to cool before surface cleaning.
2. Wipe down the exterior and top of the unit with warm water and mild detergent using a soft cloth or sponge.
3. Wipe down the interior of the hot food well with mild detergent and a damp sponge or soft cloth.
 - **Do not use excessive amounts of water.**
 - **Do not wring water out of cleaning pads into Dry Channel.**
 - Plastic scouring pads may be used to remove baked-on food.
4. Clean pans and pan covers using mild detergent and warm water, or in a dishwasher.

CAUTION Electrical shock hazard. Do not wash with water jet or hose. Do not use caustic cleaners, acids, ammonia products or abrasive cleaners or abrasive cloths. These can damage the stainless steel, Aluminum, and plastic surfaces.

IV. Troubleshooting

There are no user serviceable parts on the Duke Counter Top Soup Warmer Unit. If a malfunction occurs, then check all switches and circuit breakers. Check rating label and confirm that unit is operating at the proper voltage. If the malfunction still exists, contact your Duke Manufacturing Company authorized service agent or call 1-800-735-3853.

Product Information

V. Unit line up and Electrical Information

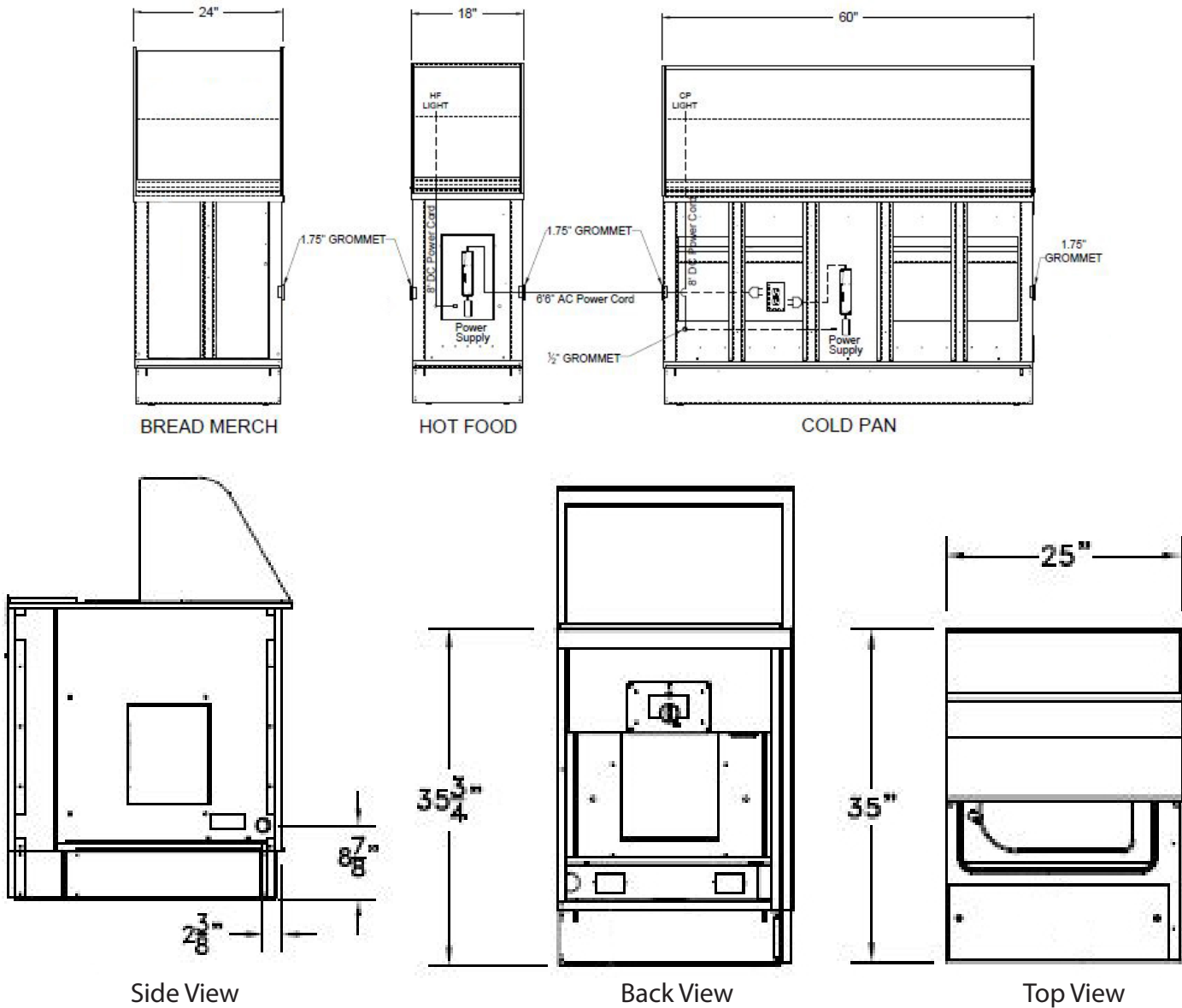

Model	Overall Length	Overall Height		Overall Depth	Electrical US			International		
		STD	ADA		Volts	Hz	Amps	Volts	Hz	Watts
SUB-HF-16.5	16.5	36"	34"	35.75	120	60	4.2	220-240	50/60	750
SUB-HF-18	18	36"	34"	35.75	120	60	4.2	220-240	50/60	750
SUB-HF-19	19	36"	34"	35.75	120	60	4.2	220-240	50/60	750
SUB-HF-21	21	36"	34"	35.75	120	60	4.2	220-240	50/60	750
SUB-HF-25	25	36"	34"	35.75	120	60	4.2	220-240	50/60	750
SUB-HF-31	31	36"	34"	35.75	120	60	4.2	220-240	50/60	750
SUB-HF-37	37	36"	34"	35.75	120	60	4.2	220-240	50/60	750
SUB-HF-49	49	36"	34"	35.75	120	60	4.2	220-240	50/60	750

120V Wire Diagram

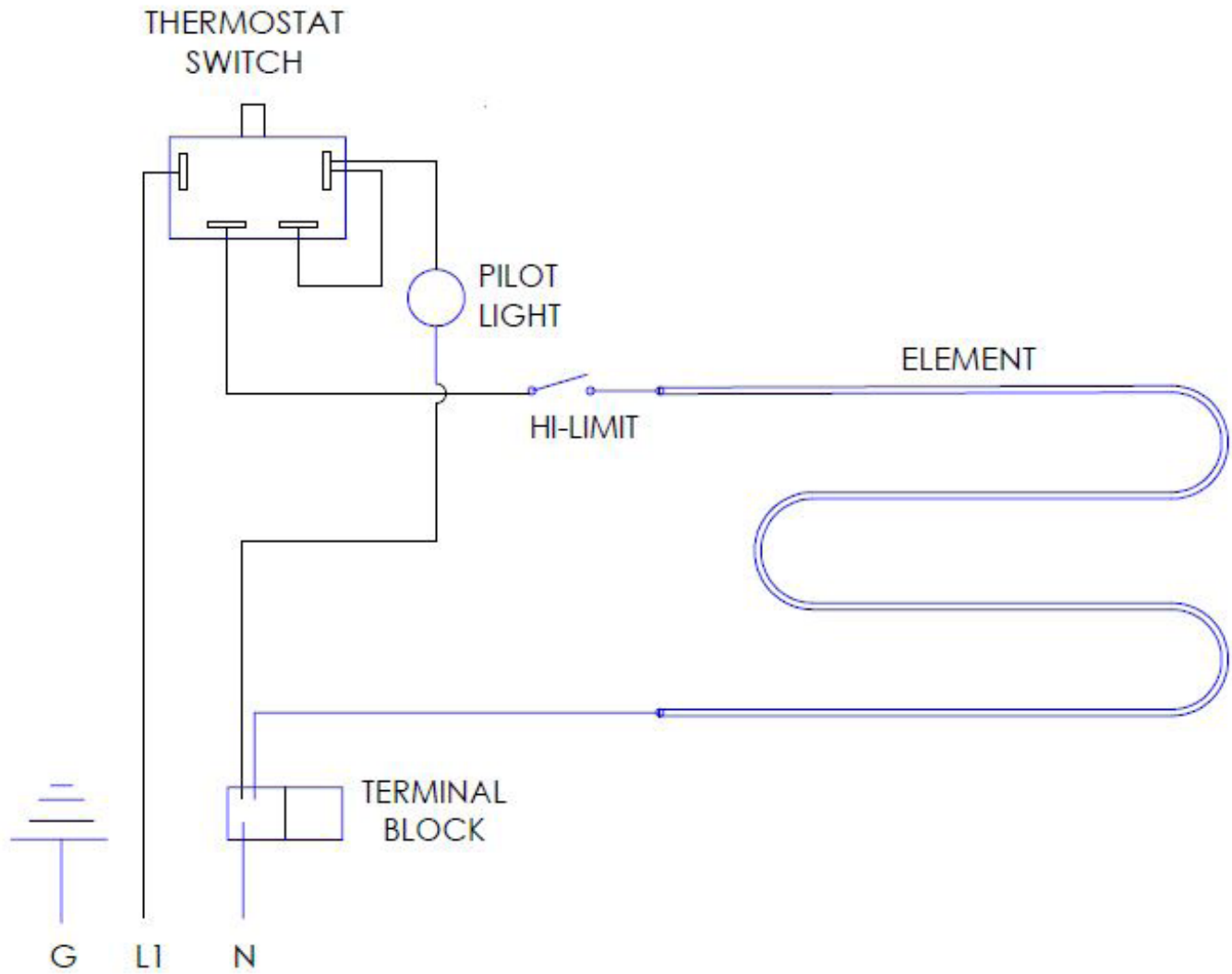

Note: "Hi-Limit switch used only on 18" and 31" sealed well units. All others no Hi-Limit in circuit."

220V Wire Diagram

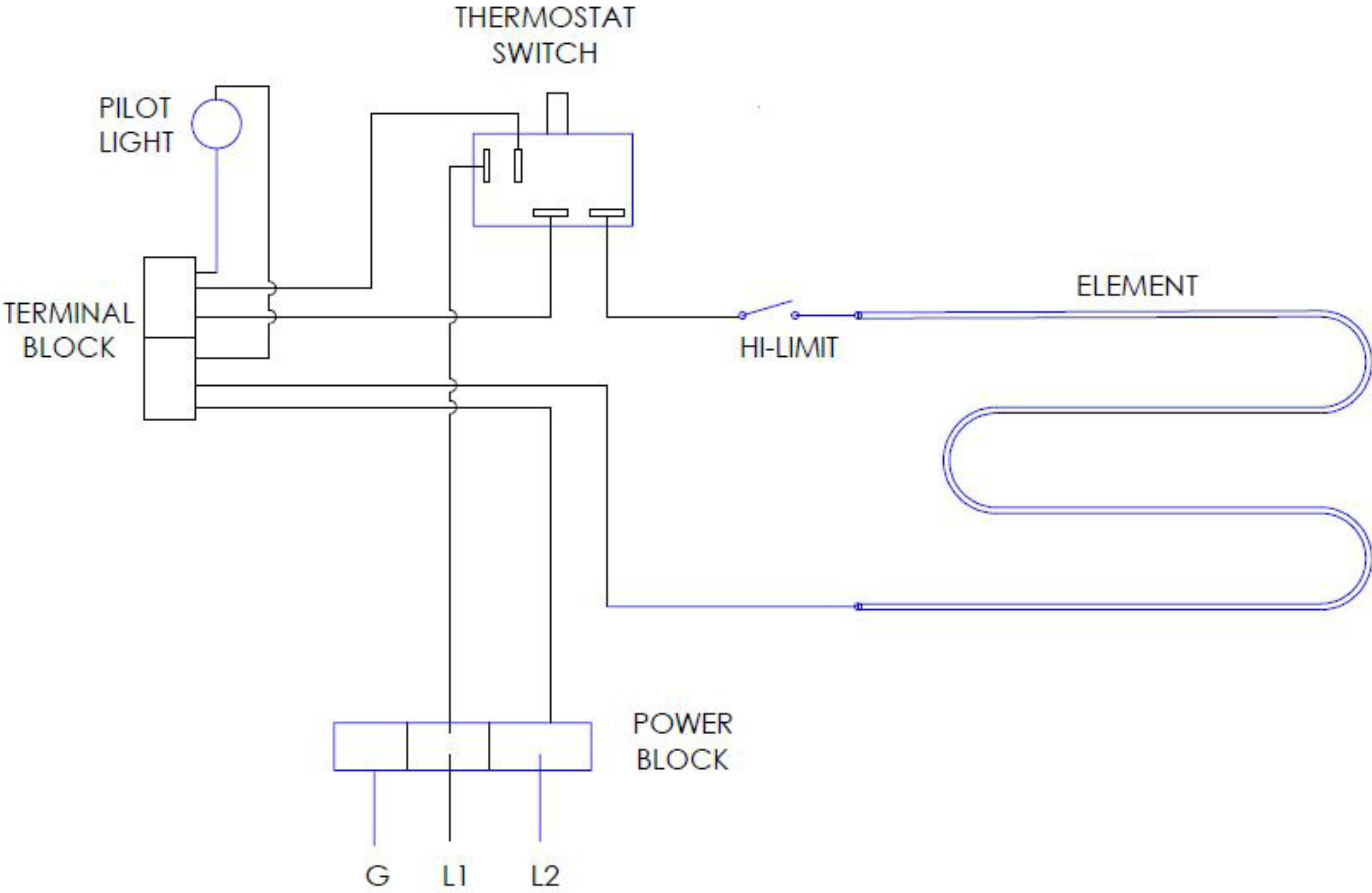

Note: " Hi-Limit switch used only on 18" and 31" sealed well units. All others no Hi-Limit in circuit."

For Customer Service

To aid in reporting this unit in case of loss or theft, please record below the model number and serial number located on the unit. We also suggest you record all the information listed and retain for future reference.

MODEL NUMBER _____	SERIAL NUMBER _____
DATE OF PURCHASE _____	
DEALER _____	TELEPHONE _____
SERVICER _____	TELEPHONE _____

TO PHONE:

Dial 1-800-735-DUKE (3853)

SERVICE

PARTS

ADDITIONAL CUSTOMER INFORMATION

TO WRITE:

Duke Manufacturing Co.

2305 N. Broadway

St. Louis, MO 63102

TO ACCESS INTERNET: www.dukemfg.com/subway

Please provide the following information when you write or call: model number, serial number, date of purchase, your complete mailing address (including zip code), and description of the problem



Your Solutions Partner

Duke Manufacturing Co.

2305 N. Broadway
St. Louis, MO 63102

Phone: 314-231-1130

Toll Free: 1-800-735-3853

Fax: 314-231-5074

www.dukemfg.com