

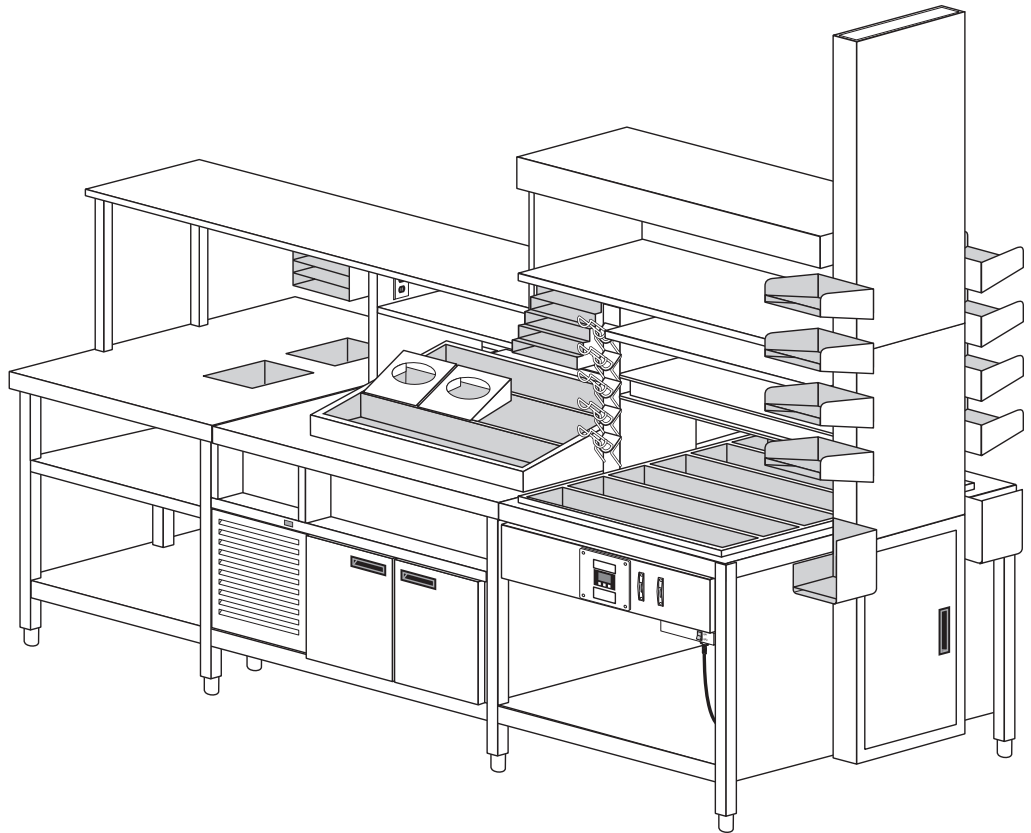

Service Manual

TACO BELL DUAL-LINE COUNTER



Please read this manual completely before attempting to install, operate or service this equipment

This document is prepared for trained Duke service technicians. It is not to be used by anyone not properly qualified to perform these procedures.

This Service Manual is not all encompassing. If you have not been trained on servicing this product, be sure to read the manual completely before attempting servicing. Be sure all necessary tools, test equipment, and skills are available. Those procedures for which you do not have the proper skills and test equipment must be performed only by a qualified Duke trained service technician.

This manual is copyright ©2011 Duke Manufacturing Company. All rights reserved. Reproduction without written permission is prohibited. Duke is a registered trademark of the Duke Manufacturing Company.

Duke Manufacturing Company

2305 N. Broadway • St. Louis, MO 63102

800.735.3853 • 314.231.1130

Fax: 314-231-5074

www.dukemfg.com

IMPORTANT WARNING AND SAFETY INFORMATION

WARNING

READ THIS MANUAL THOROUGHLY BEFORE OPERATING, INSTALLING, OR PERFORMING MAINTENANCE ON THE EQUIPMENT.

WARNING

FAILURE TO FOLLOW INSTRUCTIONS IN THIS MANUAL CAN CAUSE PROPERTY DAMAGE, INJURY OR DEATH.

WARNING

DO NOT STORE OR USE GASOLINE OR OTHER FLAMMABLE VAPORS OR LIQUIDS IN THE VICINITY OF THIS OR ANY OTHER APPLIANCE.

WARNING

DO NOT OPERATE THIS EQUIPMENT WITHOUT PROPERLY PLACING AND SECURING ALL COVER AND ACCESS PANELS.

CAUTION

Observe the following:

- Provide and maintain adequate minimum clearances from all walls and combustible materials.
- Provide and maintain adequate clearance for air openings.
- Keep the equipment area free and clear of combustible material.
- Operate equipment only on the type of electricity indicated on the specification plate.
- Retain this manual for future reference.

TABLE OF CONTENTS

TACO BELL DUAL-LINE COUNTER SPECIFICATIONS	4
INSTALLATION	4
Location	4
Leveling	4
Stabilizing	4
Electrical Connection	4
PARTS REMOVAL AND REPLACEMENT PROCEDURES	5
DRY CHANNEL FOOD WARMERS	5
Display Control Panel	5
Relay Box	5
Dry Channel Power ON/OFF Switch	5
Solid State Relay (SSR)	6
Transformer	6
Channel Assembly	6
TORTILLA GRILL AND TACO TOWER POWER ON/OFF SWITCHES	7
TRI-CHANNEL COLD PAN	7
Evaporator	8
Tri-Channel Thermostat	8
Tri-Channel Compressor Assembly	8
REFRIGERATED BASE UNIT (RBC)	9
Evaporator Fan Assembly	9
RBC Thermostat	10
RBC Refrigeration System	11
RBC Door Gaskets	11
RBC Door Adjustment	11
LOAD CENTER	12
Circuit Breaker Replacement	12
RECHARGING REFRIGERATION SYSTEM	13
TOOLS	13
Duke Service Bulletin Number 26 – Refrigeration System Evacuation	13
Duke Service Bulletin Number 35 – Accessing Sealed Refrigeration Systems	13
SERVICE INFORMATION	14
MAINTENANCE	14
Stainless Steel Care and Cleaning	14
Compressor Air Filter Care	14
TROUBLESHOOTING GUIDE	16
SCHEMATICS	18

TACO BELL DUAL-LINE COUNTER SPECIFICATIONS

MODEL	DESCRIPTION	VOLTAGE / WATTS
DC-DLTB-M	Counter, Dual-Line 157-1	120/208-240vac / 3798

INSTALLATION

LOCATION

The Dual-Line unit is intended for indoor use only. Be sure the chosen location has a floor strong enough to support the total weight of the unit fully loaded with food product. Reinforce the floor, if necessary, to provide for maximum loading. For the most efficient operation, be sure to provide good air circulation.

LEVELING

Be sure the unit is placed on a firm, flat surface/ floor. Check for cracks in flooring or tile and avoid these areas if possible. If necessary, place support pads, properly rated for the weight of the unit, to “bridge” uneven or cracked flooring. Level the unit accordingly using the leg adjusters.

STABILIZING

Use the leg adjustments to ensure that the unit is solid to the floor surface at all contact points. Ensure that the unit does not “rock” when pressure is applied to the top corners.

ELECTRICAL CONNECTION

The Dual-Line unit requires Direct wiring Dual-Line unit to the power supply must be performed by a certified electrician and must comply with local electrical codes for your municipality.



WARNING

REFER TO THE AMPERAGE DATA LIST IN THE SPECIFICATIONS OR THE SERIAL TAG DATA AND YOUR LOCAL CODE OR THE NATIONAL ELECTRICAL CODE TO BE SURE UNIT IS CONNECTED TO THE PROPER POWER SOURCE. A PROTECTED CIRCUIT OF THE CORRECT VOLTAGE AND AMPERAGE MUST BE RUN FOR CONNECTION OF THE SUPPLY CORD OR PERMANENT CONNECTION TO THE UNIT. THE POWER MUST BE TURNED OFF AND DISCONNECTED WHENEVER PERFORMING MAINTENANCE OR REPAIR FUNCTIONS.

PARTS REMOVAL AND REPLACEMENT PROCEDURES

DRY CHANNEL FOOD WARMERS

Display Control Panel

The Dual-Line unit is equipped with two Dry Channel units, one on each side of the Dual-Line. Each Dry Channel unit has its own Display Control Panel.

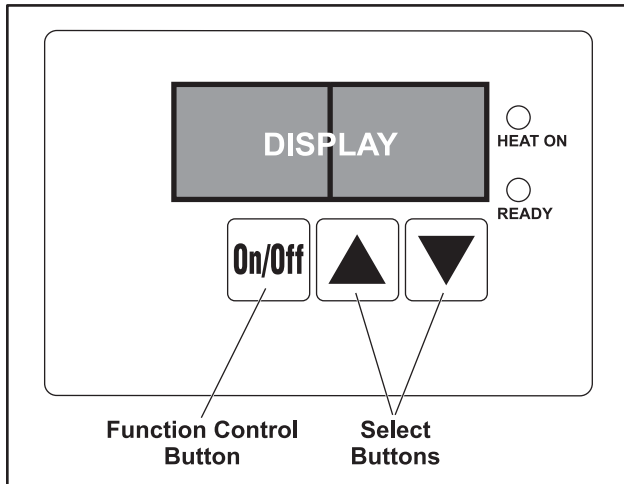

Figure 1. Dry Channel Display

1. Place the Main Power ON/OFF switch in the OFF position.
2. Disconnect the Dual-Line unit from its power source.
3. Remove the four screws securing the Display Control Panel and move Display Control Panel away from mounting surface.
4. If the Display Control Panel is to be completely removed, label and disconnect wires.
5. Remove Display Control Panel.
6. Reverse this procedure to install Display Control Panel.

Relay Box

Each Dry Channel unit is equipped with its own Relay Box. The Relay Box is located under the unit. Each Relay Box has an ON/OFF switch.

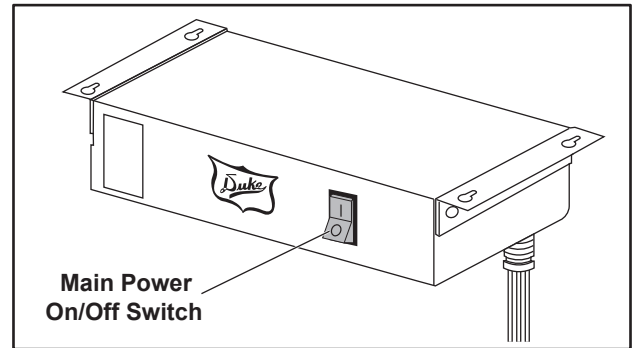

Figure 2. Relay Box Location

1. Place the Main Power ON/OFF Switch in the OFF position. Use proper Lockout/Tagout procedures.
2. Remove the four screws securing the Relay Box the bottom of the Dry Channel Unit.
3. If complete Relay Box is to be replaced, label and disconnect wires.
4. Remove the Relay Box.
5. If components in the Relay Box are to be removed, remove the Relay Box cover.
6. Reverse procedure to assemble and install Relay Box.

Note: The following component removal is based on the cover having been already removed.

Dry Channel Power ON/OFF Switch

1. Tag and disconnect the Relay Box ON/OFF Switch wires.
2. Slide the Relay Box ON/OFF Switch out through front of switch mount.
3. Reverse procedure to install a new Main Power ON/OFF Switch.

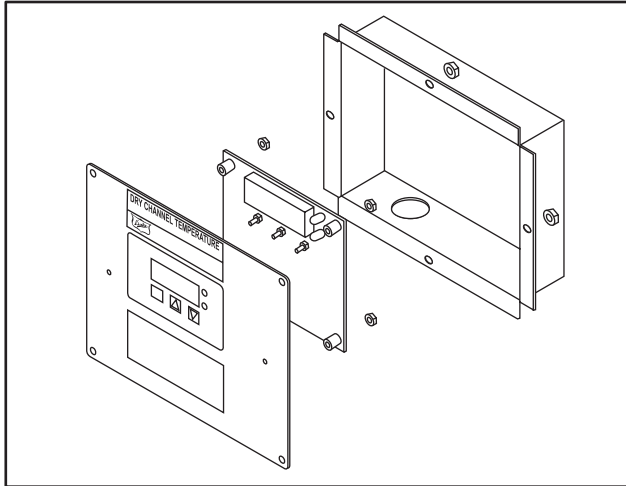

Figure 3. Exploded View of Relay Box Internal Components

Solid State Relay (SSR)

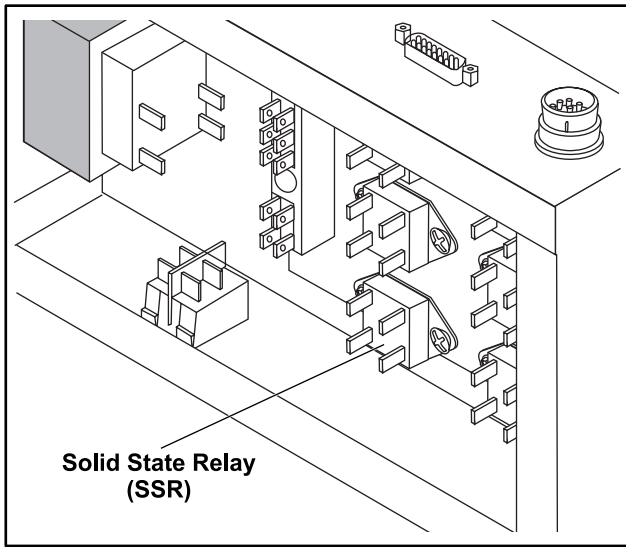

Figure 4. Solid State Relays (SSR)

1. Tag and disconnect wires from the SSR to be replaced.
2. Remove the two screws attaching the SSR and remove the SSR.
3. Reverse procedure to install a new SSR.

Transformer

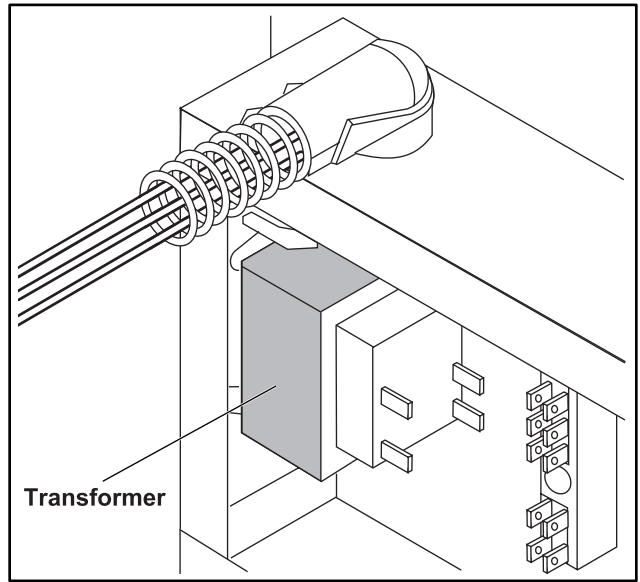

Figure 5. 240/208 Step Down Transformer

1. Tag and disconnect wires from Transformer.
2. Remove the four nuts attaching the Transformer and remove the Transformer.
3. Reverse procedure to install new Transformer.

CHANNEL ASSEMBLY

The Heat Elements, Temperature Probes and RTDs are embedded in a foil wrap that is attached to the bottom of each Channel Assembly. These parts are not serviced in the field. The entire Channel Assembly must be replaced in the event of a failure of any of these parts.

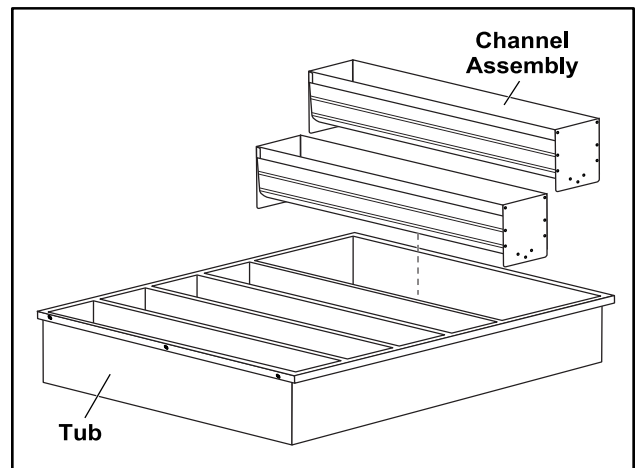

Figure 6. Dry Channel Tub Assembly

1. Place the Main Power ON/OFF Switch in the OFF position. Use proper Lockout/Tagout procedures.
2. Check that the Dual-Line is disconnected from power source.
3. Remove six screws (three on each side) attaching the channel top frame to tub.
4. Carefully lift the Channel Assembly out, taking care not to damage wire connections.
5. Label and disconnect wires from foil wrap on the Channel Assembly to the Control Board.
6. Using an ohmmeter test the resistance across the entire heating element. It should read approximately 248 ohms. Also test the RTD circuit; its normal reading is approximately 1,000 ohms. Replace the Channel Assembly if either the heater circuit or RTD circuit are reading out of tolerance.
7. Reverse this procedure to install the new Dry Channel Assembly. For end channels use part number 171263SED. Replace center channels with part number 171262SED.
8. Return the Dual-Line unit to service and check for proper operation.

TORTILLA GRILL AND TACO TOWER POWER ON/OFF SWITCHES

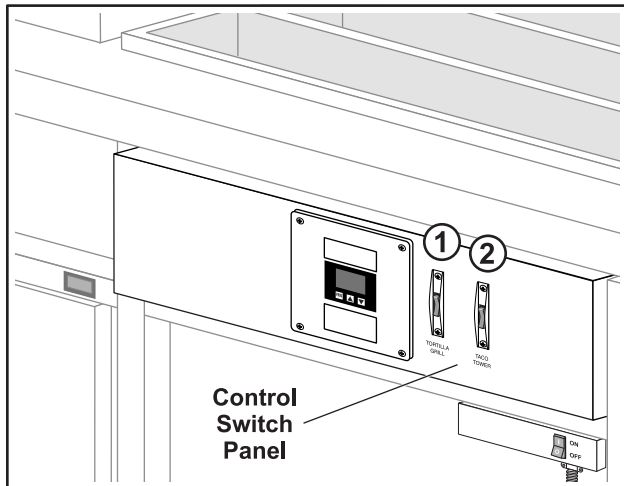

Figure 7. Location of Power ON/OFF switches

- 1: Tortilla Grill**
- 2: Taco Tower Infrared Heaters and Lights**

The Tortilla Grill and Taco Tower ON/OFF Switches are located on one side of the Dry Channel Warmer next to the Dry Channel Display.

1. Place the Main Power ON/OFF Switch in the OFF position. Use proper Lockout/Tagout procedures.
2. Remove the screws securing the switch plate.
3. Remove protective cover, if present, from the back of the switches.
4. Tag and disconnect the wires from the suspect switch.
5. Using an ohmmeter check the switch for continuity. It should read 0 ohms in the ON position and a very high reading in the OFF position. Replace the switch if it fails the continuity tests.
6. Remove two screws on front of control panel to remove faulty switch.
7. Replace existing switch with properly rated switch.
8. Refer to tags and reconnect wires.
9. Install protective cover.
10. Mount switch to mounting plate.
11. Reattach mounting plate to unit.
12. Restore Dual-Line to service and check for proper switch operation.

TRI-CHANNEL COLD PAN

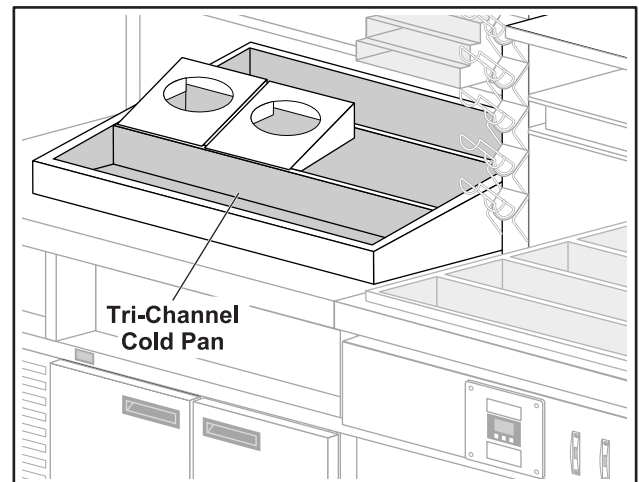

Figure 8. Tri-Channel Cold Pan Unit

The Dual-Line is equipped with two Tri-Channel Cold Pans. Both Tri-Channel Cold Pans are mounted above the refrigerator unit and angled toward the operator on each side. Refer to Duke Manufacturing Service Bulletin Number 26 and the Recharging Refrigeration System section of this manual before completing Evaporator replacement procedures.

Evaporator

The evaporator coils embedded in the body of the Tri-Channel Cold Pan are not serviceable. Replace the entire upper body if an evaporator leak or failure occurs.

1. Place Main Power ON/OFF switch in OFF position. Use proper Lockout/Tagout procedures.
2. Evacuate coolant following procedures in the RECHARGING REFRIGERATION SYSTEM section of this manual.
3. Disconnect the coolant tubing.
4. Lift Tri-Channel Pan Assembly out of Dual-Line unit.
5. Install new Tri-Channel Pan Assembly.
6. Braze coolant lines from new Tri-Channel Pan to compressor lines.
7. Charge the cooling system. Refer to the RECHARGING REFRIGERATION SYSTEM section of this manual.

Tri-Channel Thermostat

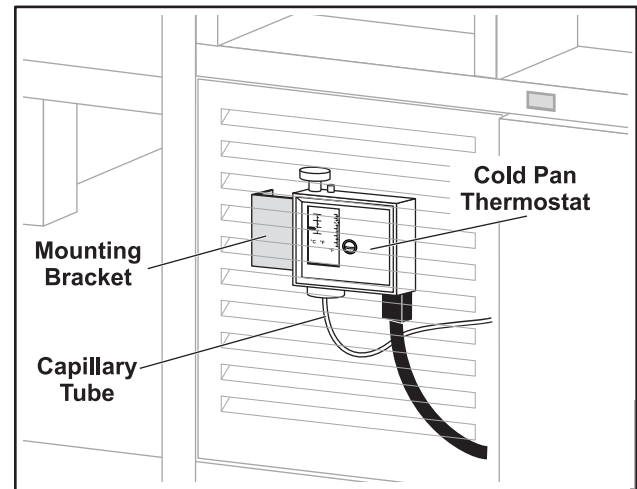

Figure 9. Location of Tri-Channel Cold Pan Thermostat

The Tri-Channel Cold Pan thermostat is located in the compressor compartment behind the louvered vent. The Tri-Channel's compressor is located next to the refrigerator doors on the side of the Dual-Line that does NOT have the refrigerator temperature display.

1. Place Main Power ON/OFF switch in OFF position. Use proper Lockout/Tagout procedures.
2. Remove the louvered vent.
3. Tag and disconnect thermostat wiring.
4. Disconnect the capillary tube.
5. Remove thermostat from mounting bracket.
6. Install new thermostat being careful not to kink capillary tube while reconnecting it.
7. Referring to tags, reconnect wires.
8. Set the thermostat according to Subway® guidelines
9. Reattach front panel and air filters.
10. Restore power to the Dual-Line.
11. Allow Tri-Channel units to cool for approximately twenty minutes before performing temperature check on each channel.
12. Adjust Thermostat as needed.

Tri-Channel Compressor Assembly

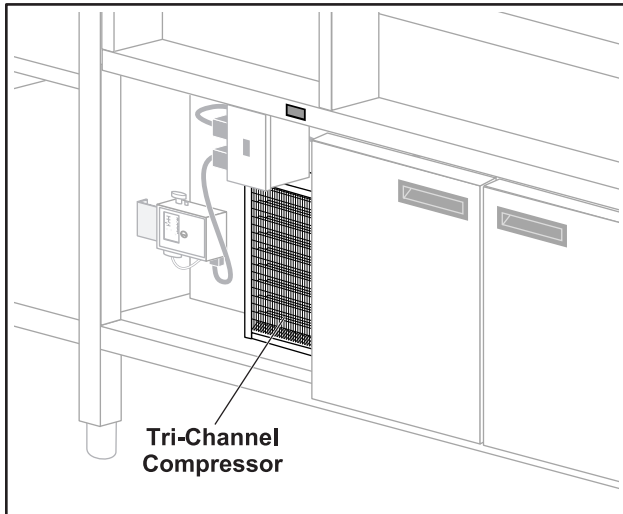

Figure 10. Compressor Assembly

The Tri-Channel Compressor Assembly is located behind the louvered vent next to the refrigerator. It is on the side of the Dual-Line that does NOT have the refrigerator temperature display.

1. Place the Main Power ON/OFF switch in the OFF position. Follow proper Lockout/Tagout procedures.
2. Remove the louvered vent.
3. Remove the air filter.
4. Remove side panel.

Note: Shelf may also be removed for easier access.

5. Tag and disconnect compressor wiring.
6. Disconnect coolant tubing from evaporator unit. Refer to the RECHARGING REFRIGERATION SYSTEM section of the manual for proper evacuation procedures.
7. Remove mounting bolts.
8. Slide compressor unit out through the front of the unit.
9. Install new compressor assembly.
10. Reattach; braze coolant lines.
11. Reconnect compressor wiring.
12. Reconnect wiring.

13. Charge the cooling system. Refer to the RECHARGING REFRIGERATION SYSTEM section of this manual for proper charging procedures.
14. Attach air filter and all panels.
15. Restore Dual-Line to service and check for proper compressor operation.

REFRIGERATED BASE UNIT (RBC)

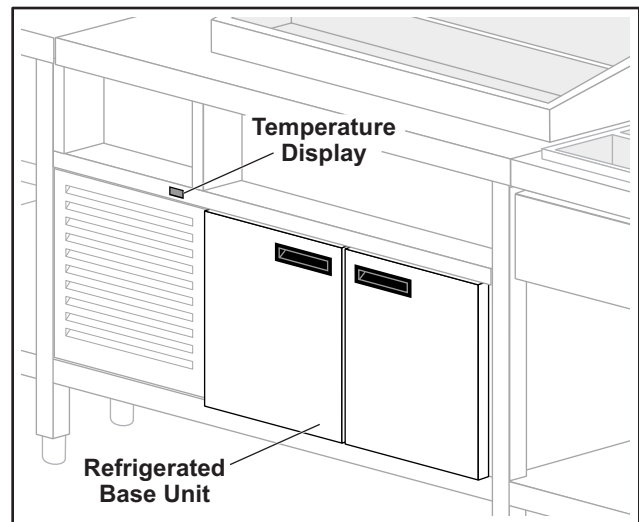

Figure 11. Refrigerator Unit with Temperature Display

The refrigerator unit is located below the Tri-Channel Cold Pan Unit. The refrigerator can be accessed from both sides of the Dual-Line. The side with the temperature display is considered to be the front of the refrigerator unit. The refrigerator's compressor is located behind the louvered vent to the left of the left front door.

Evaporator Fan Assembly

The Evaporator Fan Assembly is accessed through the louvered panel on the inside of the RBC. The assembly is equipped with two fans.

1. Place the Main Power ON/OFF switch in the OFF position. Use proper Lockout/Tagout procedures.
2. Open the RBC doors and remove the shelf for easier access to the louvered panel.

- Remove the louvered panel on the inside wall of the RBC to gain access to the Evaporator Fan Assembly.

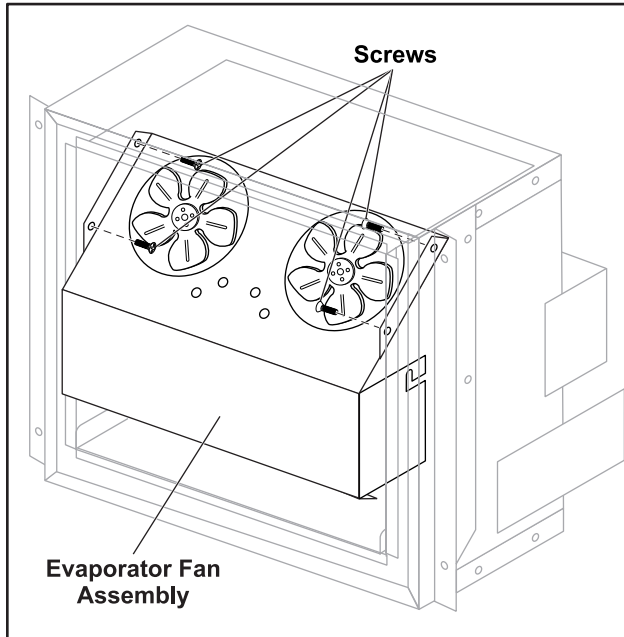

Figure 12. Evaporator Fan assembly

- Remove the screws securing the Evaporator Fan Assembly to the Evaporator Assembly.
- Carefully lift the Evaporator Fan Assembly out of the Evaporator Assembly. Be careful not to pull too hard on the fan wiring.

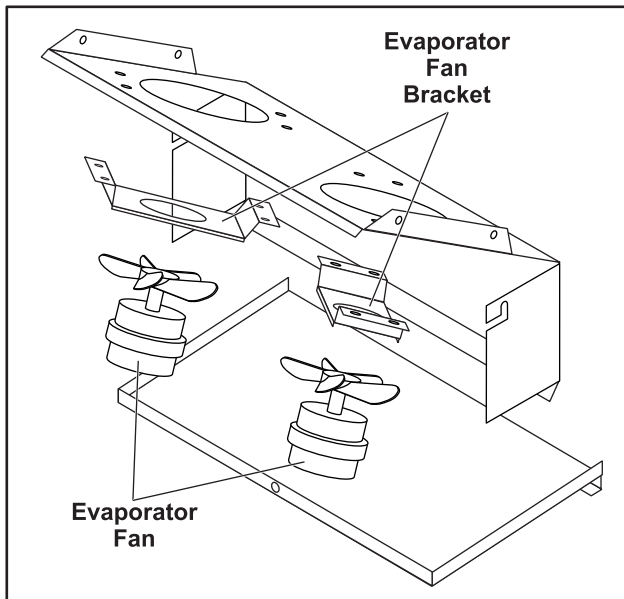

Figure 13. Evaporator Fans

- Tag and disconnect the Evaporator Fan wires.
- A separate bracket secures each fan; remove the 2 nuts securing the faulty fan.
- Reverse this procedure to install a new Evaporator Fan

RBC Thermostat

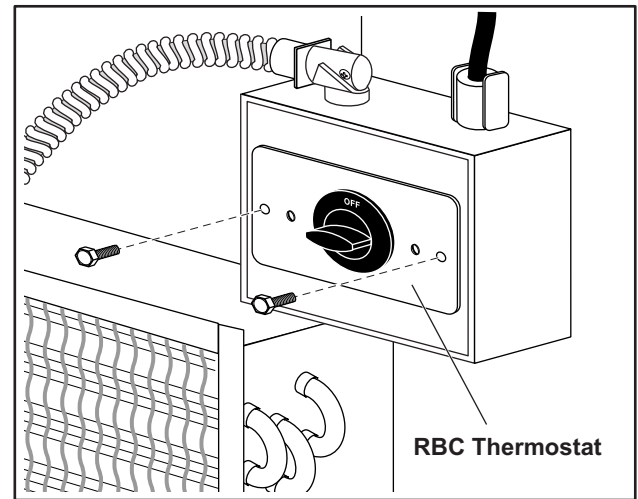

Figure 14. Location of Refrigerator Thermostat

The RBC Thermostat is located in the compressor compartment behind the louvered vent.

- Place Main Power ON/OFF switch in the OFF position. Use proper Lockout/Tagout procedures.
- Open the louvered vent.
- Tag and disconnect RBC Thermostat wiring.
- Disconnect the capillary tube; be careful not to kink the tube.
- Remove the RBC Thermostat from the mounting bracket.
- Reverse these procedures to install a new RBC Thermostat.
- Set the new thermostat according to Subway® standards.
- Restore power to the Dual-Line; monitor the RBC for proper operation.
- Readjust the thermostat setting as needed.

RBC Refrigeration System

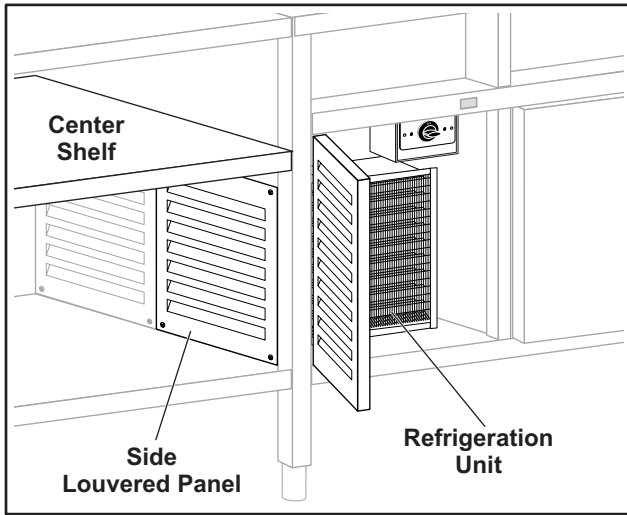

Figure 15. RBC Refrigeration System

1. Place Main Power ON/OFF switch in the OFF position. Use proper Lockout/Tagout procedures.
2. Evacuate coolant following procedures in the RECHARGING REFRIGERATION SYSTEM section of this manual.
3. Remove center shelf for easier access.
4. Remove the side louvered panel.
5. Tag and disconnect wiring.
6. Remove Refrigeration Unit mounting hardware.
7. Remove the screws holding the evaporator assembly to the RBC cabinet.
8. Reverse this procedure to install new Refrigeration Unit.

RBC Door Gaskets

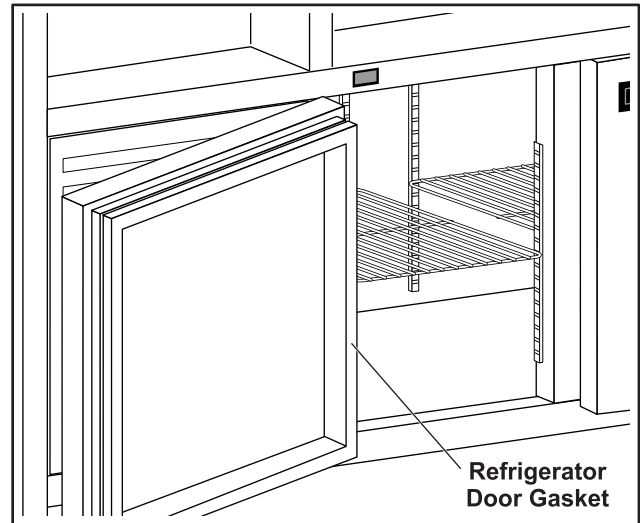

Figure 16. Refrigerator Door Gasket

The RBC unit is a 4-door model with access from both sides of the Dual-Line. Two of the doors, one on each side, are larger. For the larger door use 19-inch gasket, part number [216636](#). The smaller doors use a 17-inch gasket, part number [216645](#).

1. Pull gasket out of door panel groove.
2. Press new gasket in groove.
3. Ensure door seals properly. To test for proper seal use a sheet of paper approximately the size of dollar bill. Close the door on the piece of paper; it should pull snugly.
4. Adjust door as necessary.

RBC Door Adjustment

Over time, and with repeated use, the RBC doors may begin to sag. When this occurs, door adjustment is required.

1. Open the sagging door to its full open position.
2. Check hinges for tightness. If they are loose, snug them up but don't over-tighten them.
3. Place a flat-headed screwdriver against the inside edge of the top hinge. Tap it with a small hammer, using light taps until the door is lined up.

4. Repeat for the bottom hinge if needed.
5. Tighten all the hinge screws.

LOAD CENTER

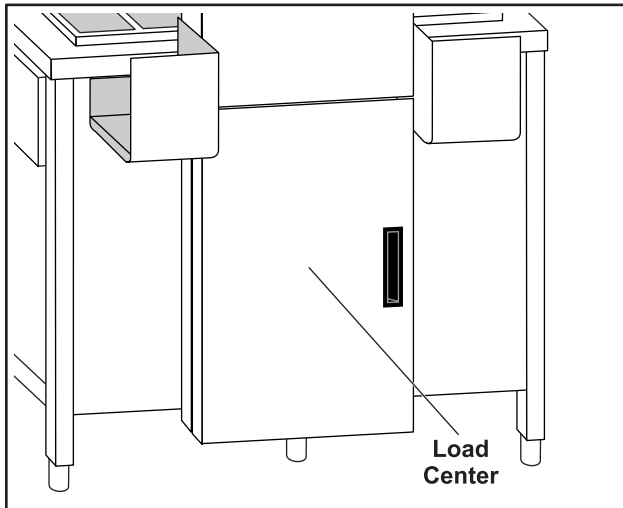

Figure 17. Location of Dual-Line Load Center

The Load Center is located behind the cabinet door on the end of the unit nearest the Dry Channel Warmer.

Circuit Breaker Replacement

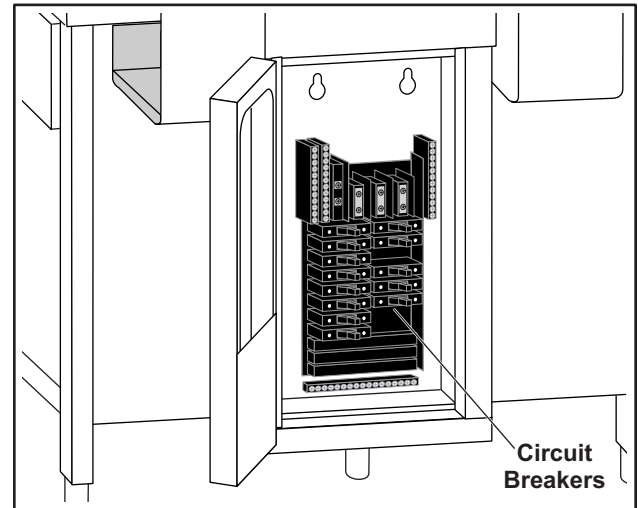

Figure 18. Location of Circuit Breakers

Place the Main Power ON/OFF switch in the OFF position. Follow proper Lockout/Tagout procedures.

1. Tag and disconnect the affected circuit breaker wires.
2. Pull circuit breaker out of its mounting slots.
3. Push the new circuit breaker into the slot; ensure that it locks into position.
4. Refer to the tags, and reconnect the wires.
5. Restore the Dual-Line to service and check the circuit breaker for proper operation.

Note: Refer to Troubleshooting section if replacement breaker does not solve problem.

RECHARGING REFRIGERATION SYSTEM

TOOLS

- Standard hand and refrigeration tools
- Refrigerant Type: R-134A or R0404A. Refer to the unit's identification plate for the correct refrigerant type.

DUKE SERVICE BULLETIN NUMBER 26 – REFRIGERATION SYSTEM EVACUATION

Note: Prior to refrigeration system service, special care must be taken during the evacuation process to remove air, moisture and other non-condensable gasses from the system. Duke Manufacturing recommends the following triple evacuation method. Failure to follow this procedure may result in poor refrigeration system performance.

1. Evacuate system to 1500 microns.
2. Break vacuum to 2 psig with dry nitrogen. If dry nitrogen is unavailable, use same type of refrigerant as used in system.
3. Evacuate system to 1500 microns.
4. Break vacuum to 2 psig with dry nitrogen. If dry nitrogen is unavailable, use same type of refrigerant as used in system.
5. Evacuate system to 500 microns. The system is now ready to receive refrigerant charge according to information on data plate.



WARNING

NEVER USE OXYGEN OR ACETYLENE IN PLACE OF REFRIGERANT AND DRY NITROGEN FOR LEAK TESTING. A VIOLENT EXPLOSION MAY RESULT, CAUSING PERSONAL INJURY OR DEATH. ALWAYS USE A PRESSURE REGULATOR WHEN USING NITROGEN TO PRESSURE TEST. FAILURE TO DO SO WILL RESULT IN EXTREMELY HIGH PRESSURE, WHICH COULD EXCEED THE BURST PRESSURE OF THE COMPRESSOR OR OTHER SYSTEM COMPONENTS AND RESULT IN PERSONAL INJURY OR DEATH.

DUKE SERVICE BULLETIN NUMBER 35 – ACCESSING SEALED REFRIGERATION SYSTEMS

To analyze the performance of a refrigeration system, record temperature readings. Convert temperature into pressure using a standard pressure/temperature chart. When it is necessary to service a factory sealed refrigeration system and return it to its properly sealed condition, strictly adhere to the following approved procedure.

Note: Ensure that there is enough process hose (approximately 12") available to complete the repair. If not, install a new process hose before repair sequence.

1. Install a temporary access valve on the high and low sides of process hoses as close to factory crimps as possible.
2. Use temporary valves to perform repair.

Note: Duke Manufacturing will not reimburse the cost of permanently installed valves.

3. After completing repair, evacuate system using the triple evacuation method.
4. After completing proper evacuation method, recharge system, using proper refrigerant according to information on the data plate.

Refrigerated Base Unit: 8 oz of R-134a refrigerant

Tri-Channel Cold Pan Unit: 16 oz of R404a refrigerant

5. Continue crimping process hose just below temporary valve and again 2" below crimp.
6. With crimp tool in place, remove temporary valve.
7. Braze shut end of process hose.
8. Allow to cool for about 5 minutes.
9. Remove crimp tool.
10. Check brazed end for leaks.

SERVICE INFORMATION

MAINTENANCE

Stainless Steel Care and Cleaning

Stainless steel contains 70-80% iron. Iron will rust. It also contains 12-30% chromium. Chromium forms an invisible, passive film over the steel surface and acts as a shield against corrosion. As long as the protective film remains intact, the metal will not corrode. However, if the film is broken or contaminated, outside elements can begin to break down the steel and begin to form rust or discoloration. To prevent rust and discoloration on stainless steel, several important steps are required.

CAUTION: Never use steel wool pads, wire brushes, scrapers or cleaners containing abrasives.



Avoid cleaning solutions that contain alkaline or chloride.

Use non-alkaline based or non-chloride cleaning solutions. Anything containing chloride will damage the protective film on stainless steel. Chlorides are found in household and industrial cleaners and also in hard water and salts. If a chloride or alkaline cleaner has been used, rinse repeatedly and dry thoroughly.

Always use only soft cloths or plastic scouring pads. For routine cleaning, use warm soapy water. For stubborn stains use a non-abrasive cleanser. For heavy grease use a degreaser. For best results, rub with the grain of the steel.

Pitting and cracking are early signs of stainless steel breakdown. Special stainless steel cleaners can restore and preserve the protective film. If signs of breakdown appear, thoroughly clean and dry all surfaces. Begin regular application of a high quality stainless steel cleaner according to the manufacturer's instructions. Again, always rub with the grain of the steel for best results.

CAUTION: Never use an acid-based cleanser! Be sure to clean all food products from any stainless surface. Many food products contain acid, which can deteriorate the finish. Common foods include tomatoes, peppers and other vegetables.



COMPRESSOR AIR FILTER CARE

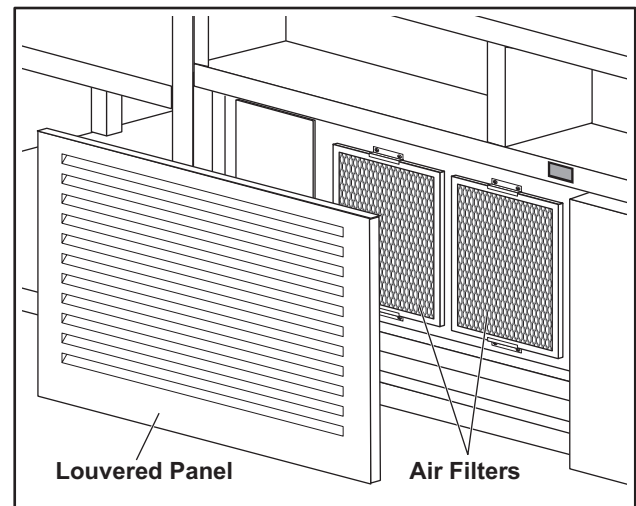

Figure 19. Location of Compressor Air Filters

The Compressor Air Filters are located behind the large louvered vent mounted on the front and rear of the unit. Clean the air filters with mild soap and water once a month.

1. Lift the louvered vent panel up and away from the front of the unit.
2. Gently pull the filters out of their mountings.

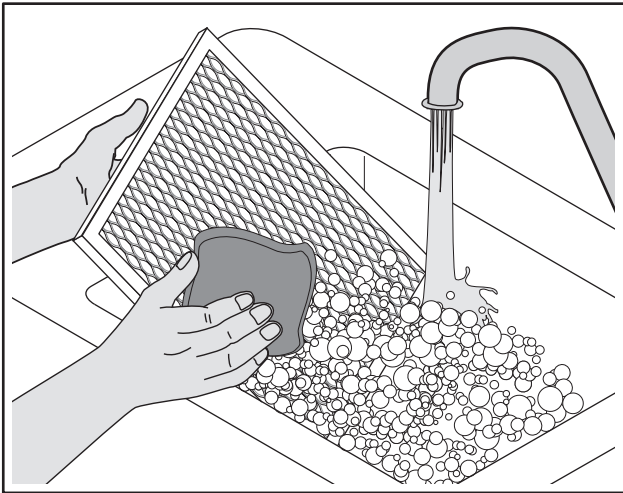

Figure 20. Air Filter

3. Wash the filters in a mild soap and warm water solution.
4. Rinse with warm water.

CAUTION: Do not use a high-pressure hose to rinse the filters.



The high pressure water will damage the filter mesh.

5. Allow the filters to dry thoroughly before reinstalling them.
6. Install filter and reattach the louvered vent.
7. If replacement filters are required refer to the parts list for the correct part number.

TROUBLESHOOTING GUIDE

SYMPTOM	POSSIBLE CAUSE	REMEDY
Dual-Line does not operate.	No Power	Make sure Main Power switch is in the ON position Check Main Circuit Breaker
Dual-Line has power but Tortilla Grill does not heat.	No Power Bad Power Switch Open Tortilla Grill Heat Element	Make sure Tortilla Grill Power Switch is in the ON position. Check Tortilla Grill Circuit Breaker in Load Center. Replace Tortilla Grill Power Switch. Replace Tortilla Grill Heat Element
Dual-Line unit has power but Dry Channel Unit will not heat.	No Power Bad Power Switch Display Control Panel Malfunction Relay Box failure	Make sure Dry Channel Power Switch is in the ON position. Check Dry Channel Display Control Panel setting; should be 275°F. Check Dry Channel Circuit Breakers. Replace Power Switch. Replace the Display Control Panel. Replace the Relay Box
Dry Channel unit is working but one channel does not heat	Open Heat Element circuit	Replace Channel Assembly.
Dual-Line unit has power but Taco Tower doesn't heat or light.	No Power	Make sure Taco Tower Power Switch is in the ON position. Check Taco Tower Circuit Breaker
Taco Tower lights come on but it doesn't heat.	Failed Infrared Heater	Replace Infrared Heater.
Dual-Line unit has power but Tri-Channel unit doesn't get cold.	No Power	Make sure Tri-Channel Unit Power Switch is in the ON position. Check Tri-Channel Unit Circuit Breaker. Check Thermostat setting

TROUBLESHOOTING GUIDE (CONTINUED)

SYMPTOM	POSSIBLE CAUSE	REMEDY
Tri-Channel Unit doesn't get cold.	Coolant Leak	Repair Leak referring to Duke Service Bulletin Number 26. Replace Cold Pan. Replace Compressor Assembly.
	Defective Thermostat	Replace Tri-Channel Thermostat.
	Dirty Compressor Air Filter	Clean or replace Air Filter.
	Failed Condenser Cooling Fan	Replace Condenser Cooling Fan.
	Condenser Motor Failure	Replace Condenser Assembly.
Dual Line has power but Refrigerator does not get cold.	No Power	Check Refrigerator Unit Circuit Breaker.
	Thermostat Setting	Check Thermostat Setting.
	Defective Thermostat	Replace Thermostat.
	Dirty Compressor Air Filter	Clean or replace Air Filter.
	Failed Condenser Cooling Fan	Replace Condenser Cooling Fan.
	Coolant Leak	Repair Leak referring to Duke Service Bulletin Number 26. Replace Compressor unit if needed. Replace Evaporator unit if needed.
	Evaporator Fan Failure	Replace Evaporator Fan Assembly.
	Door Gaskets Leaking Excessively	Replace Door Gaskets.

SCHEMATICS

3-PHASE, 208/120V, 200A LOAD CENTER

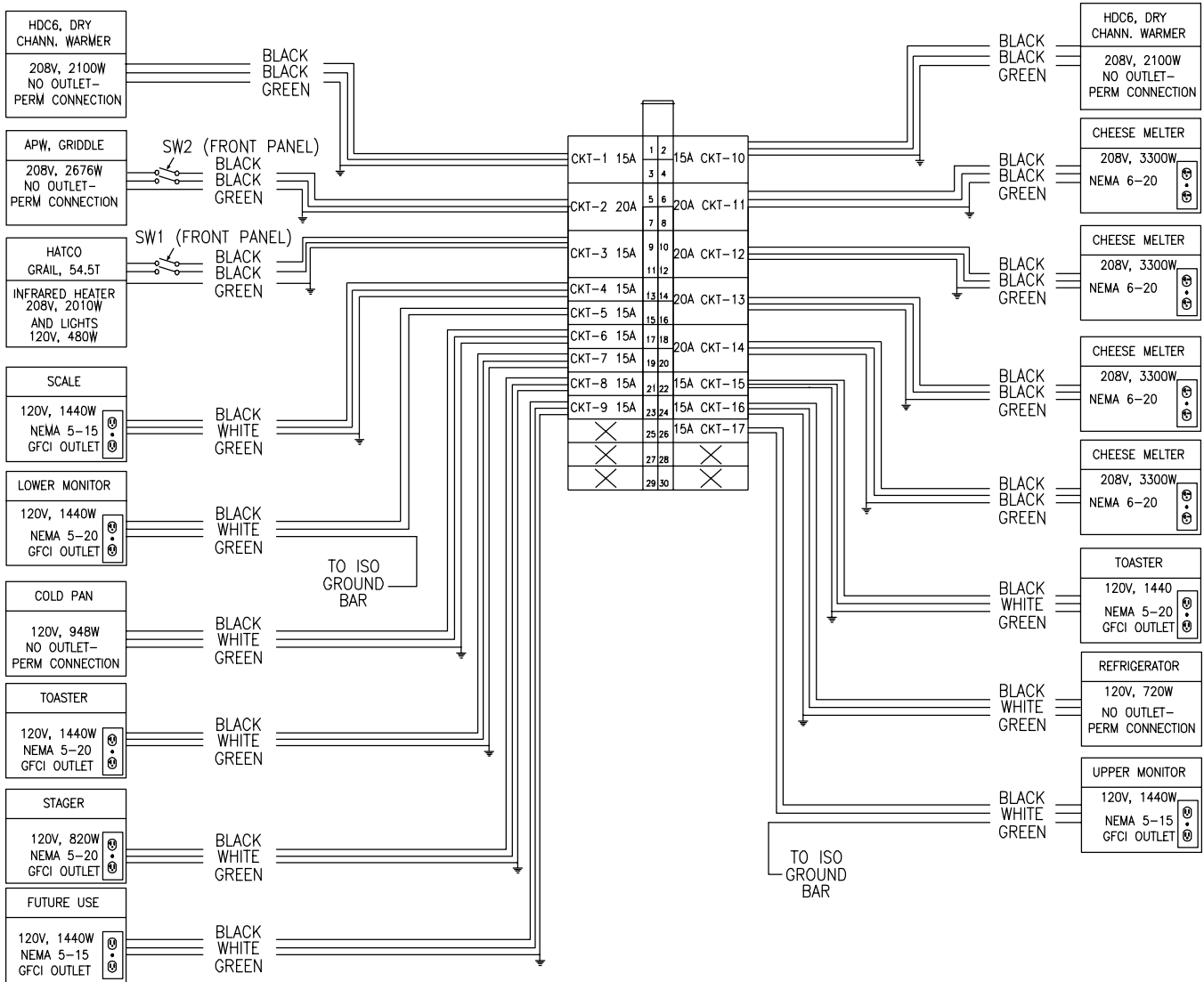
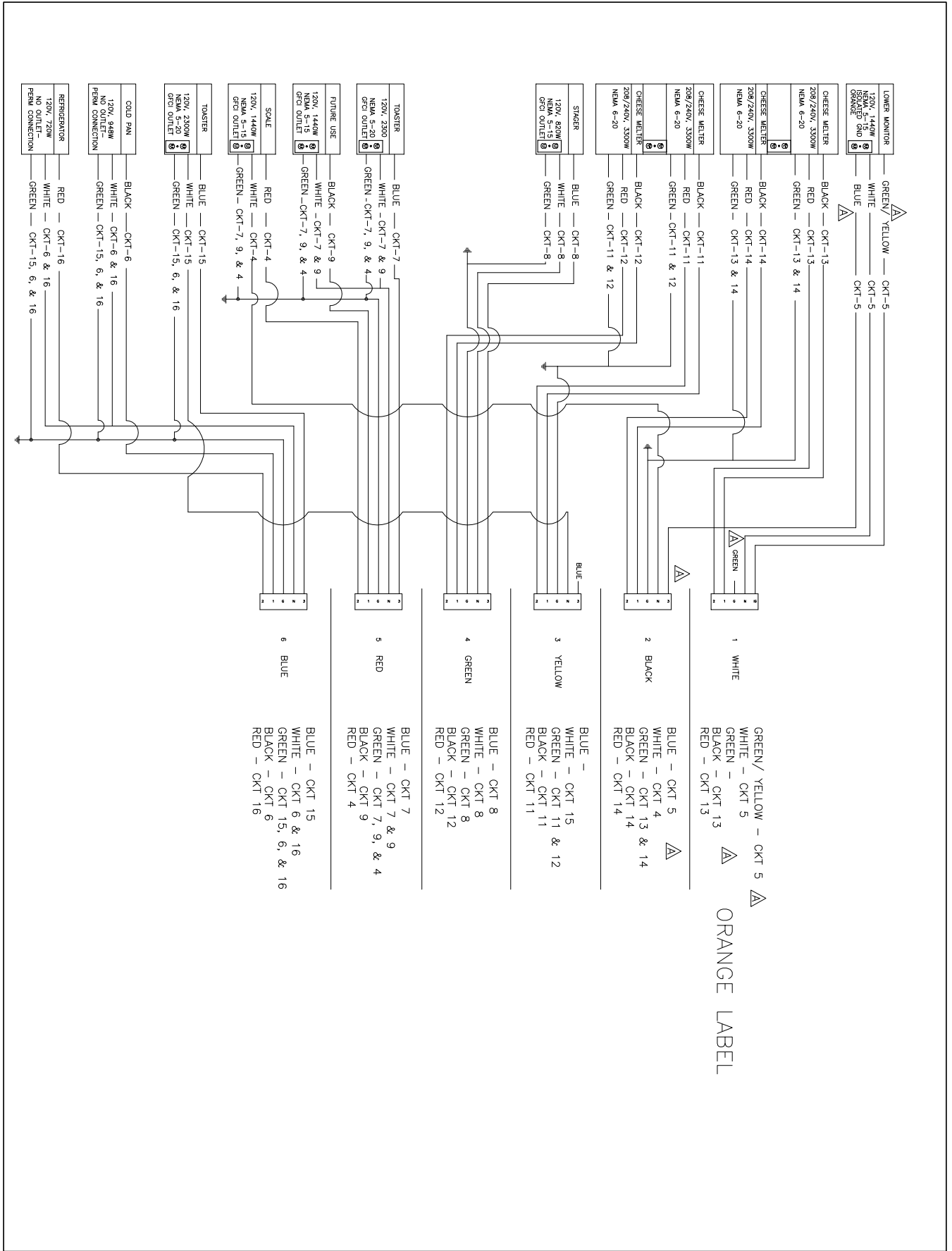

Figure 21. Circuit Diagram

Figure 22. Load Center Diagram

PANEL #1			TACO BELL DUAL LINE COUNTER						200 AMP PANEL 30 P			
120/208V - 3PH - 4W - S/N						120 Amp Minimum Panel Amperage						
POSITION NUMBER	CIRCUIT NUMBER	BRKR. SIZE	ITEM #/ EQUIPMENT SERVED	EQUIPMENT VOLTAGE	LOAD (VA)	PHASE WIRE	LOAD (VA)	EQUIPMENT VOLTAGE	ITEM #/ EQUIPMENT SERVED	BRKR. SIZE	CIRCUIT NUMBER	POSITION NUMBER
1	1	15	HDC6	208	2100	A	2100	208	HDC6	15	10	2
3						B						4
5	2	20	APW GRIDDLE	208	2676	C	3300	208	MELTER	20	11	6
7						A						8
9	3	15	GRAIL 45T W/LIGHTS	208	2490	B	3300	208	MELTER	20	12	10
11				120		C						12
13	4	15	SCALE	120	1440	A	3300	208	MELTER	20	13	14
15	5	15	LOWER MONITOR	120	1440	B						16
17	6	15	COLD PAN	120	948	C	3300	208	MELTER	20	14	18
19	7	15	TOASTER	120	1440	A						20
21	8	15	STAGER	120	820	B	1440	120	TOASTER	15	15	22
23	9	15	FUTURE USE	120	1440	C	720	120	REFRIGERATOR	15	16	24
25						A	1440	120	UPPER MONITOR	15	17	26
27						B						28
29						C						30
3 PHASE PANEL BOX				11808	VA	A	33694 KVA :TOTAL LOAD					
				9630	VA	B						
				12256	VA	C						





Duke Manufacturing Company

2305 N. Broadway • St. Louis, MO 63102

800.735.3853 • 314.231.1130

Fax: 314-231-5074

www.dukemfg.com