

DUAL LINE AND I-LINE OPERATION AND INSTALLATION INSTRUCTIONS

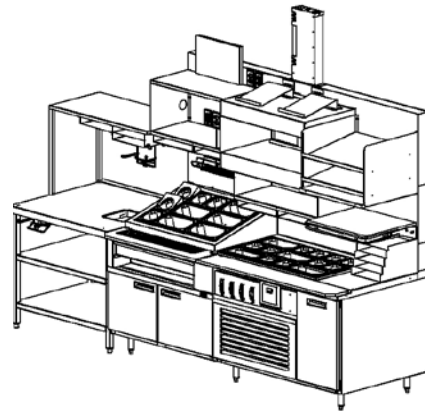
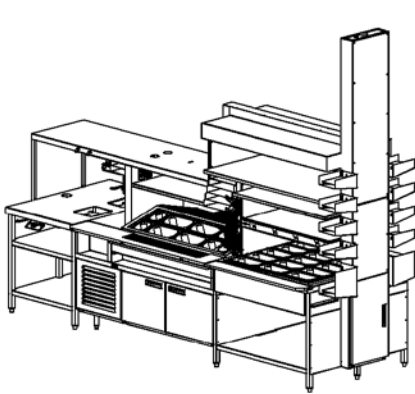

For information or technical assistance, call:

TOLL FREE

(800) 735-DUKE (3853)

or

(314) 231-1130

Notice: Read this entire Installation Manual prior to installing or operating this equipment.
Inspect all components immediately after unpacking.
Notify the Carrier of any damage to this equipment

*This manual is Copyright ©2006 Duke Manufacturing Company. All rights reserved.
Reproduction without written permission is prohibited. Duke is a registered
trademark of the Duke Manufacturing Company.*



IMPORTANT WARNING AND SAFETY INFORMATION

WARNING - READ THIS MANUAL THOROUGHLY BEFORE OPERATING, INSTALLING, OR PERFORMING MAINTENANCE ON THE EQUIPMENT.

WARNING - FAILURE TO FOLLOW INSTRUCTIONS IN THIS MANUAL CAN CAUSE PROPERTY DAMAGE, INJURY OR DEATH.

WARNING - DO NOT STORE OR USE GASOLINE OR OTHER FLAMMABLE VAPORS OR LIQUIDS IN THE VICINITY OF THIS OR ANY OTHER APPLIANCE.

WARNING - DO NOT OPERATE THIS EQUIPMENT UNLESS ALL COVER AND ACCESS PANELS ARE IN PLACE AND PROPERLY SECURED.

CAUTION

- Minimum clearances must be maintained from all walls and combustible materials.
- Keep the equipment area free and clear of combustible material.
- Adequate clearance for air openings.
- Operate equipment only on the type of electricity indicated on the specification plate.
- Retain this manual for future reference.

RECEIVING AND INSPECTING THE EQUIPMENT

Care should be taken during unloading so the equipment is not damaged while being moved into the building.

1. Visually inspect the exterior of the package and skid or container. Any damage should be noted and reported to the delivering carrier immediately.
2. If damaged, open and inspect the contents with the carrier.
3. In the event that the exterior is not damaged, yet upon opening, there is concealed damage to the equipment notify the carrier. Notification should be made verbally as well as in written form within 48 hours of receipt of goods.
4. Request an inspection by the shipping company of the damaged equipment. This should be done within 10 days from receipt of the equipment.
5. Check the lower portion of the unit to be sure legs are not bent.
6. Also view compressor compartment housing and visually inspect the refrigeration package. Be sure lines are secure and base is still intact.
7. Freight carriers can supply the necessary damage forms upon request.
8. Retain all shipping material until an inspection has been made or waived.

Installation Verification List



The following is a list of items that need to be verified and checked after installation is complete.

- Verify the unit is level.
- Verify that tables (sections) are fastened together.
- Verify all the Duke supplied components are located according to the installation diagrams.
- No water leaks at the supply bulkhead fitting at top of chase.
- No water leaks at the termination of the cheese melter.
- Verify open drain line for cheese melter (no obstructions).
- Dual Line: verify electrical channel wire support is installed between the HF table and the RB unit.
- No pinched/cut wires in the wiring harness.
- Verify all wiring connections are secure and correct per the wiring diagram.
- Verify all vinyl has been removed from the stainless steel.

Table of Contents



IMPORTANT WARNING AND SAFETY INFORMATION	Page 2
INSTALLATION VERIFICATION LIST	Page 3
TACO BELL DRY MODULAR DUAL LINE DRAWINGS	Page 5-6
DUAL LINE APPLIANCE SETUP	Page 7
FIELD ASSEMBLY DUAL LINE WATER KIT	Page 8
LOWER ELECTRICAL CHASE REMOVAL	Page 9
DUAL LINE ASSEMBLY INSTRUCTIONS	Page 10-17
TACO BELL DRY MODULAR I-LINE DRAWINGS	Page 18
I-LINE APPLIANCE SETUP	Page 19
FIELD ASSEMBLY I-LINE WATER KIT	Page 20
I-LINE ASSEMBLY INSTRUCTIONS	Page 21-23
INTRODUCTION	Page 24
SERIAL NUMBERS	Page 24
OPERATION	Page 25
MAINTENANCE	Page 26-27
WIRING DIAGRAMS REFRIGERATION	Page 28
TROUBLE SHOOTING	Page 28
SERVICE PARTS LIST	Page 29-32

TACO BELL DRY MODULAR DUAL LINE STANDARD 157" MODEL

- 1) EXTENSION TABLE 43"
- 2) COLD FOOD UNIT
- 3) DRY HEAT TABLE W/ ELECTRICAL PANEL
- 4) EXTENSION TABLE / COLD FOOD OVERSHELF ASSEMBLY
- 5) UPPER WIRECHASE EXTENSION
- 6) TACO HEATER ASSEMBLY
- 7) TACO SHELF
- 8) TORTILLA SHELF
- 9) TORTILLA GRIDDLE
- 10) PANEL BOX
- 11) WATER LINE INLET
- 12) MAIN POWMER SUPPLY INLET
- 13) WALK-UP DRY HEAT MAIN POWMER
- 14) WALK-UP DRY HEAT TEMP DISP / CONTROL PANEL
- 15) DRIVE-UP DRY HEAT MAIN POWMER
- 16) DRIVE-UP DRY HEAT TEMP DISP / CONTROL PANEL
- 17) POWMER SWITCH TORTILLA GRIDDLE
- 18) POWMER SWITCH TACO HEATER
- 19) REMOVABLE WRAPPER SHELVES
- 20) SMALL BINS DRIVE-UP SIDE
- 21) SMALL BINS WALK-UP SIDE
- 22) LARGE BIN WALK-UP SIDE
- 23) LARGE BIN WALK-UP SIDE
- 24) TOP WATER LINE CHASE W/ COVER
- 25) SIDE WATER LINE CHASE W/ COVER
- 26) HF CARVING BOARD
- 27) RB CARVING BOARD
- 28) TACO RAIL
- 29) ADD ON BOTTLE HOLDER

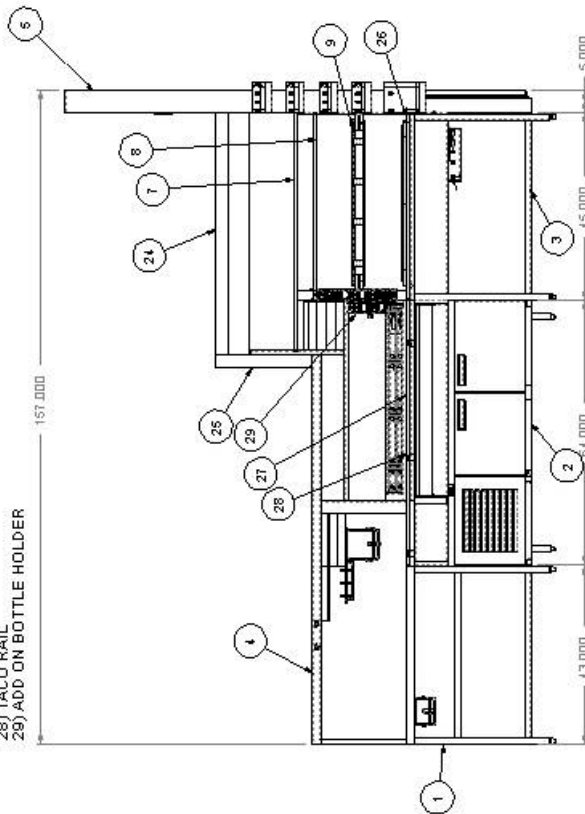

FRONT ELEVATION WALK-UP SIDE

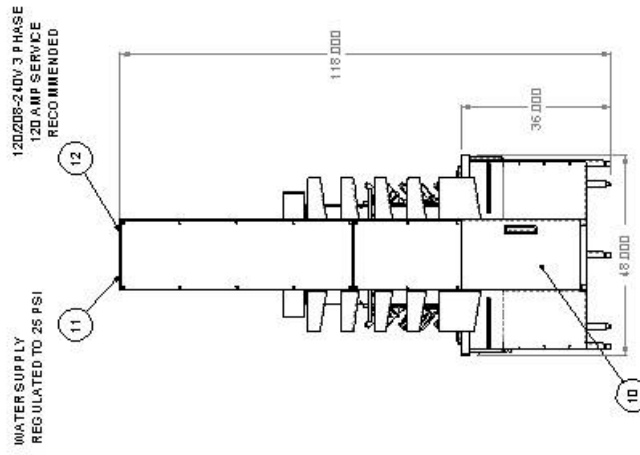

200 AMP PANEL BOX
LOCATED BEHIND DOOR

END VIEW

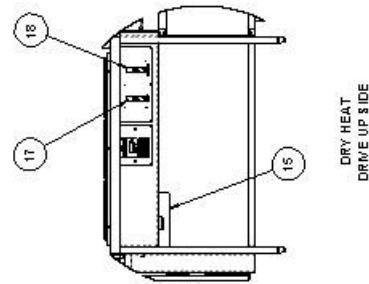

DRY HEAT
DRIVE UP SIDE

TACO BELL DRY MODULAR DUAL LINE OPTIONAL 145" MODEL

- 1) EXTENSION TABLE 43"
- 2) COLD FOOD UNIT
- 3) DRY HEAT TABLE W/ ELECTRICAL PANEL
- 4) EXTENSION TABLE / COLD FOOD OVERSHELF ASSEMBLY
- 5) UPPER W/RECHASE EXTENSION
- 6) TACO HEATER ASSEMBLY
- 7) TACO SHELF
- 8) TORTILLA SHELF
- 9) TORTILLA GRIDDLE
- 10) PANEL BOX
- 11) WATER LINE INLET
- 12) MAIN POWER SUPPLY INLET
- 13) WALK-UP DRY HEAT MAIN POWER
- 14) WALK-UP DRY HEAT TEMP DISP / CONTROL PANEL
- 15) DRIVE-UP DRY HEAT MAIN POWER
- 16) DRIVE-UP DRY HEAT TEMP DISP / CONTROL PANEL
- 17) POWER SWITCH TORTILLA GRIDDLE
- 18) POWER SWITCH TACO HEATER
- 19) REMOVABLE WRAPPER SHELVES
- 20) SMALL BINS DRIVE-UP SIDE
- 21) SMALL BINS WALK-UP SIDE
- 22) LARGE BIN DRIVE-UP SIDE
- 23) LARGE BIN WALK-UP SIDE
- 24) TOP WATER LINE CHASE W/ COVER
- 25) SIDE WATER LINE CHASE W/ COVER
- 26) HF CARVING BOARD
- 27) RB CARVING BOARD
- 28) TACO RAIL
- 29) ADD ON BOTTLE HOLDER

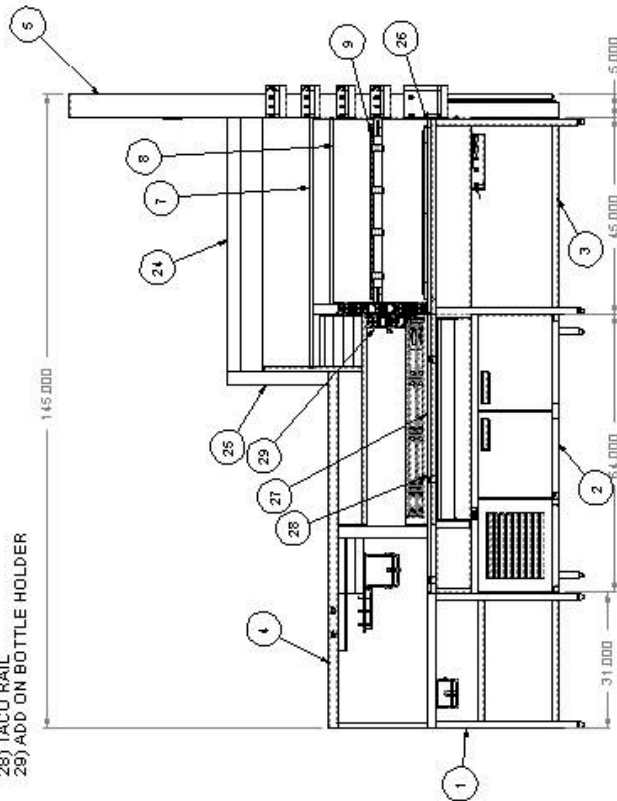

FRONT ELEVATION WALK-UP SIDE

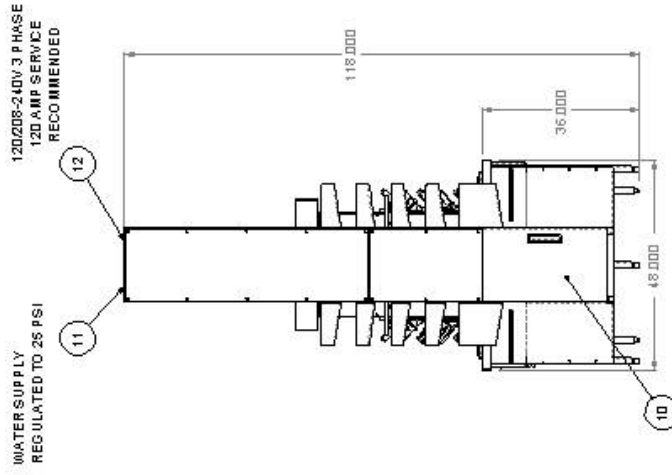

200 AMP PANEL BOX
LOCATED BEHIND DOOR

END VIEW

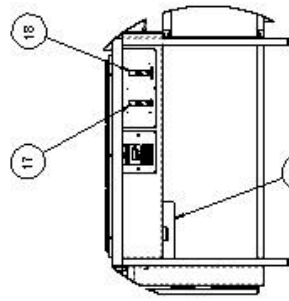

DRY HEAT
DRIVE UP SIDE

DUAL LINE APPLIANCE SET UP

- A) MONITORS
- B) CHEESE MELTERS
- C) DESSERT TOWER
- D) DIGITAL SCALES
- E) CLAM SHELL GRILLS (TOASTERS)

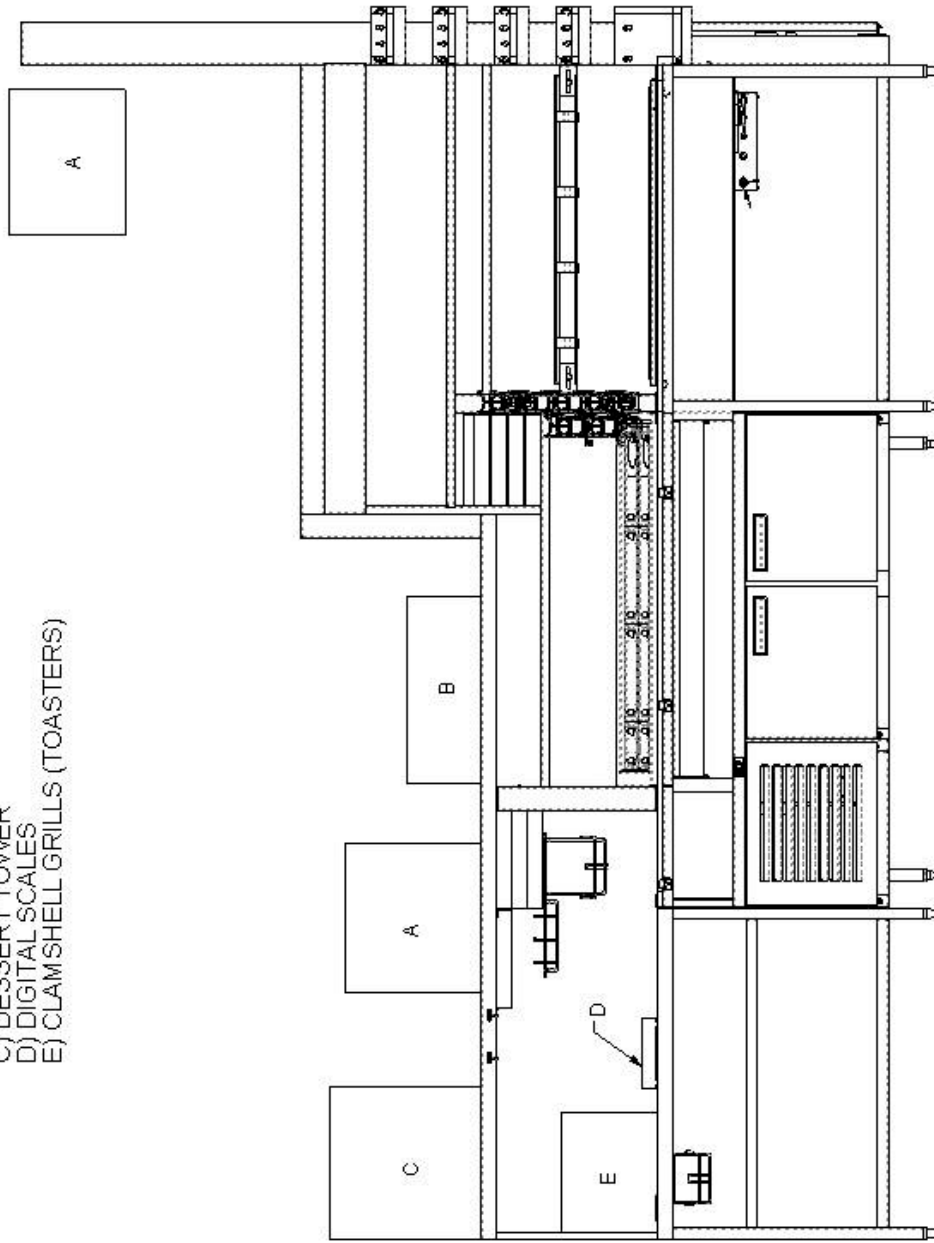

FRONT ELEVATION WALK-UP SIDE

ITEM NO.	QTY.	PART #	DESCRIPTION	DESCRIPTION 2
1	3	212752	Ø1/4" TEE BARBED	
2	6	212754-5	Ø1/4" POLYURETHANE HOSE 5" LENGTH	
3	2	212753	Ø1/4" ELBOW 90°	
4	13	212783	CLAMP, HOSE WORM GEAR 7/32" - 5/16"	
5	2	212754-21	Ø1/4" POLYURETHANE HOSE 21" LENGTH	

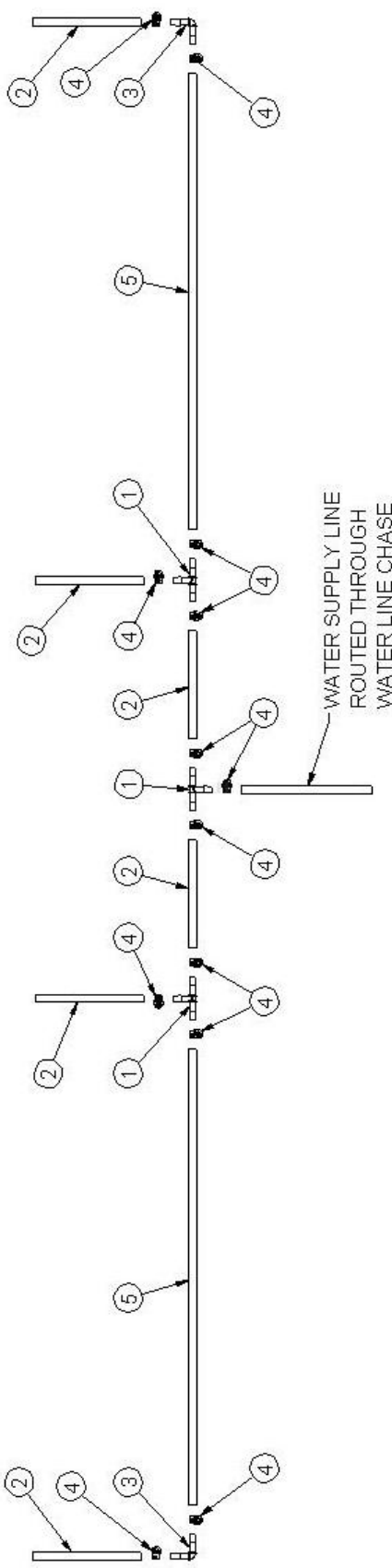

**FIELD ASSEMBLY OF DUAL LINE CHEESE MELTER WATER SUPPLY
DUAL LINE WATER LINE KIT #551045**

Dual Line Assembly Instructions



CHASE REMOVAL/ REINSTALLATION STEPS (ONLY IF NECESSARY)

1. Remove door from chase (Fig. 1).
2. Remove bottom plate by removing (4) 1/4"-20 x 1/2" Hex Head Screws on bottom of chase with 3/8" wrench (Fig. 2).
3. Remove spring caps from holes (Fig. 3) and loosen (4) 1/4"-20 x 1" Hex Head Screws 2-3 turns (Fig. 4) (requires 3/8" socket on extension or a long 3/8" nutdriver).
4. Slide lower chase up 3/4" and remove from table through keyhole slots for screw heads and around load center (Fig. 5).
5. To re-install, place lower chase on side of table, slide behind load center until keyhole slots line up with screw heads.
6. After keyhole slots engage the screws, slide down 3/4" and tighten the 1/4"-20 x 1" Hex Head Screws.
7. Replace the spring caps in the holes they came from.
8. Replace the bottom plate on the bottom of the chase and tighten 1/4"-20 x 1/2" Hex Head Screws. Pull the sides of the lower chase in so that the gap between the sides and the bottom rail is as small as possible before tightening (Fig. 6).
9. Replace the door on the unit.
10. Apply silicone around lower chase where it meets the table (Fig. 7).



Fig. 1



Fig. 2



Fig. 3



Fig. 4

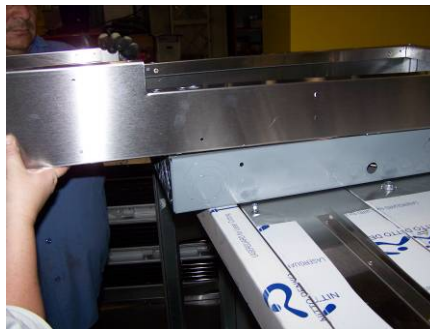

Fig. 5

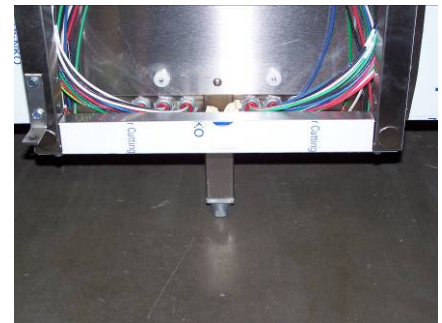

Fig. 6



Fig. 7

Dual Line Assembly Instructions

STEP A: BASE UNIT SET UP

1. Place Extension Table (Fig. 8), Cold Food Unit (Fig. 9), and Dry Heat Table (Fig. 10) in the store in the approximate location.
2. Set electrical connectors on bottom shelf of Dry Heat Table and slide Dry Heat Table and Cold Food Unit together, being careful not to pinch any of the electrical conduits (Fig. 11).
3. Connect the electrical connectors by matching colors of each half of the connection (Fig. 12). Connections can only be made one way, note tabs and slots (Fig. 13 & 14).
4. When all connections are made it should look like Fig. 15.
5. Secure cover to legs of Dry Heat Table with screws (Fig. 16).
6. Level all of the units. Begin with all of the feet adjusted in (Fig. 17) Level the Cold Food Unit first, then proceed to level each of the tables (Fig. 18) All of the tops should line up and be straight and level when complete.
7. Secure each of the tables to the Cold Food Unit using the hardware supplied in kit #215674. The Dry Heat Table will be secured using (2) hex screws #213029. The Extension Table will be secured using (2) hex screws #213029 and (2) hex nuts #213042. (Fig. 19)



Fig. 8



Fig. 9



Fig. 10



Fig. 11



Fig. 12



Fig. 13



Fig. 14



Fig. 15



Fig. 16

Dual Line Assembly Instructions



Fig. 17



Fig. 18



Fig. 19

STEP B: OVERHEAD SHELVING SETUP

1. Carefully unpack the Extension Table / Cold Food Overshelf assembly and set it in place. Be sure to leave the corrugated support blocks in place while it is being moved, otherwise damage could result. (See Fig. 20)
2. Use hardware kit #215675 to assemble the overhead shelving to the base units.
3. Place shelf legs over support blocks on table and secure with (4) screws #213028 (Fig. 21).
4. Secure wrapper shelf to Dry Heat Table pylon with (3) screws #213029.
5. Secure overshelf to Cold Food Unit pylon with (3) screws #213023 and wrapper shelf to Cold Food Unit pylon with (3) screws #213029. (Fig. 22).



Fig. 20



Fig. 21



Fig. 22

Dual Line Assembly Instructions



STEP C: VERTICAL ELECTRICAL CHASE SETUP

1. Use hardware kit #215676 to assemble the Vertical Electrical Chase.
2. Place Upper Chase Extension on top of load center chase with receptacle towards top (Fig. 23) and secure with (10) screws #213029. Be sure bottom channel back plate is removed to allow access to all bolting locations (Fig. 24).
3. Secure bottom channel back plate with (4) screws #213029.
4. Route wires from receptacle box down through chase and grommet holes to load center to be wired later.



Fig. 23

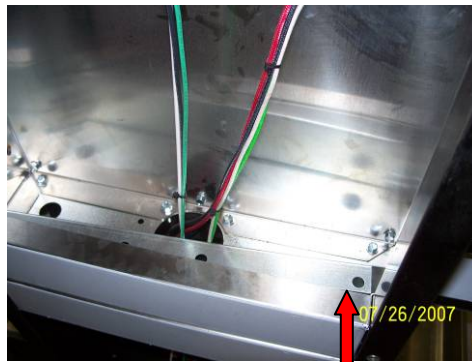

Fig. 24

STEP D: HEATED SHELF ASSEMBLY

1. Use hardware kit #215677 to assemble the Heated Shelf Assembly.
2. Set Heated Shelf Assembly into place and support while routing heater wires through hole into Upper Chase Extension (Fig. 25). Route heater wires down through Upper Chase Extension to be wired later.
3. Secure Heated Shelf Assembly to Upper Chase Extension and backing plate using (3) screws #213029 (Fig. 26).
4. Secure Heated Shelf Assembly to shelf pylon using (3) screws #213029 (Fig. 27).
5. Fasten pylon cover plate using (12) screws #213051.

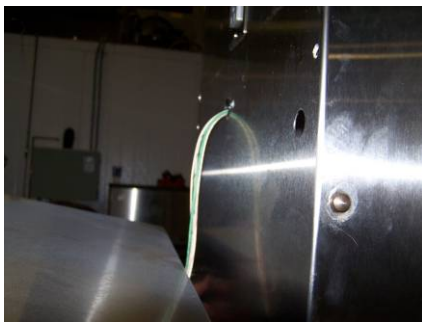

Fig. 25



Fig. 26



Fig. 27

Dual Line Assembly Instructions



STEP E: TACO SHELF ASSEMBLY

1. Use hardware kit #215678 to assemble the Taco Shelf Assembly.
2. Set Taco Shelf into place on top of Dry Heat Table pylon and support. Secure Taco Shelf to Upper Chase Extension with (3) screws #213029 (Fig. 28).
3. Secure Taco Shelf to Dry Heat Table pylon using (3) screws #213023 and to upper shelf pylon cover using (3) screws #213029 (Fig. 29).
4. Attach braided water line to bulkhead fitting using (1) hose clamp #212783 from water line kit #551045. Route water line down Upper Chase Extension through hole and into water line chase (Fig. 30). Push water line through hole and lay in top water line chase (Fig. 31) and attach cover with (10) screws #213028.
5. Attach side water chase to pylon with (2) screws #213051 & run water line down side water line chase and through hole in cover plate (Fig. 32-33). Attach cover plate with (6) screws #213028.
6. Attach plastic drain line fittings from Overhead Shelf Assembly to drain lines in Cold Food Unit pylon (Fig. 34).
7. Ensure all water and drain line fittings are tight and without kinks.
8. Secure chase to underside of overshelf with (8) screws #213028 (Fig. 34).
9. Secure pylon cover on Dry Heat Table pylon using (12) screws #213051.

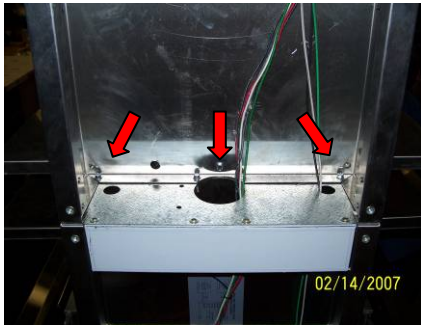

Fig. 28



Fig. 29



Fig. 30



Fig. 31



Fig. 32



Fig. 33



Fig. 34

Dual Line Assembly Instructions



STEP F: TORTILLA SHELF ASSEMBLY

1. Set the Tortilla Shelf in place and support.
2. Using hardware kit #215679, secure shelf to Upper Chase Extension and Dry Heat Table pylon using (6) screws #213029 (Fig. 35-36).



Fig. 35



Fig. 36

STEP G: TORTILLA GRIDDLE ASSEMBLY

1. Remove (4) bolts supplied with griddle from mounting locations in each corner of griddle.
2. Set Tortilla Griddle inside mounting brackets between load center chase and Dry Heat Table pylon and support in place (Fig. 37).
3. Carefully route all wires coming out of Griddle through hole in load center chase and secure conduit fitting with nut (Fig. 38 & 39).
4. Make sure griddle is centered and level and secure to mounting brackets using the (4) bolts (Fig. 40).
5. Run wires through grommet in top of load center (Fig. 41).
6. Remove griddle relay box cover.
7. Run wires down and through conduit fitting in back of load center (Fig. 42).
8. Wires will come out of load center and run through conduit into the relay box (Fig. 43).
9. Connect wires per APW Wiring Diagram (Fig. 44). **DO NOT CUT ANY OF THE WIRES DOWN.**
10. Gather up excess wire and place in relay box.
11. Replace relay box cover.



Fig. 37



Fig. 38

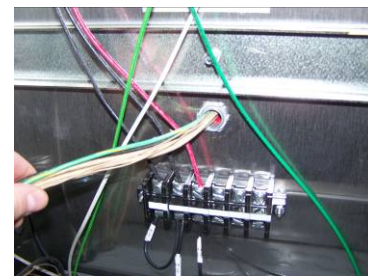

Fig. 39



Fig. 40

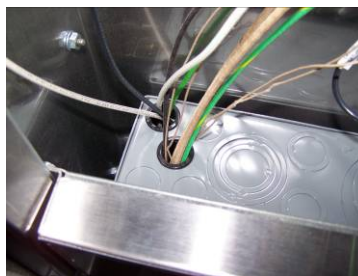

Fig. 41

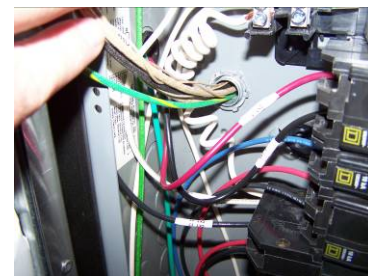

Fig. 42

Dual Line Assembly Instructions



Fig. 43



Fig. 44

STEP H: CHEESE MELTER WATER LINE SETUP

1. Using Water Line Kit #551045, assemble cheese melter water line hookups per diagram on page 8.
2. Attach water feeds to each fitting on cheese melters (Fig. 45). (2 per double cheese melter).
3. Attach plastic drain line to drain fitting on bottom of cheese melter (Fig. 46).
4. **NOTE: Plumbing contractor is to supply water line to bulkhead fitting in top of Upper Chase Extension and ensure all water line connections are tight. Duke MFG Co. recommends the installation of a shut off valve at, or prior to, supply connection.**



Fig. 45



Fig. 46

STEP H: MISC. PARTS SETUP

1. All misc. wrapper bins and shelving can be put in place using appliance set up diagram on page 7 as a guide.
2. Keyhole mount wrapper bins are secured to Upper Chase Extension and load center chase using button pins.

STEP H: WRAPPER SHELF INSTALLATION

1. Attach bag rack to wrapper shelf with (4) #10-24 x 3/8 Truss Head Screws and (4) #10-24 Nylon Lock Nuts using a long Phillips Head screwdriver and 3/8" wrench (Fig. 47).
2. Attach 3-tier wrapper shelf to Melter Pylon Cover loosely with (2) #10-24 x 3/8" Truss Head Screws (Fig. 48). After the rest of the shelf is attached, completely tighten.
3. Line up tabs in the 3-tier and single tier wrap shelves and attach to center channel with (2) #10-24 x 1/2" Phillips Head Self Tapping Screws (Fig. 49).
4. Attach other end of single tier wrap shelf to channel with (2) #10-24 x 1/2" Phillips Head Self Tapping Screws (Fig. 50).
5. Attach Pizza Cutter Hooks with (2) #6-32 x 3/8" Phillips Head Screws (Fig. 51).

Dual Line Assembly Instructions



Fig. 47



Fig. 48



Fig. 49



Fig. 50



Fig. 51



ELECTRICAL CONNECTIONS

1. Electrical contractor can wire monitor receptacle and heaters, etc. using wiring diagram and panel schedule supplied with unit.
2. Main power supply connection can be made from ceiling through wire chase to load center (Fig. 52-53).
3. Attach vertical wire chase covers with hardware kit #215682 using (16) 1/4-20 x 1/2" truss head screws (Fig 54).



Fig. 52

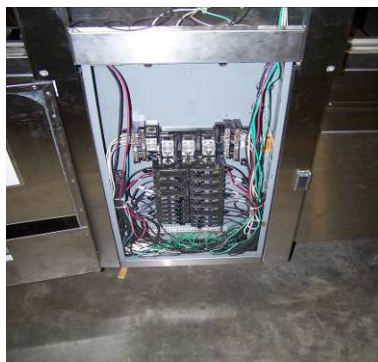

Fig. 53



Fig. 54



Dual Line Assembly Instructions

CARVING BOARDS, TACO RAIL, AND ADD ON BOTTLE HOLDER

1. Attach carving board brackets to front of unit with supplied #10-24 x 3/4" screws (Fig. 55).
2. Set HF carving board in place in front of the hot food well (Fig. 56).
3. Set RB carving board in place in front of the cold rail (Fig. 57).
4. Set the Taco Rail in place inside the cutout in the carving board (Fig. 58).
5. Attach add on sauce bottle holders to hot well side of the 5-bottle holder.



Fig. 55



Fig. 56



Fig. 57



Fig. 58

TACO BELL DRY MODULAR I-LINE

- 1) EXTENSION TABLE
- 2) REFRIGERATED BASE UNIT W/ TRI-CHANNEL COLD RAIL & DRY HEAT
- 3) EXTENSION TABLE OVERSHELF
- 4) TORTILLA GRIDDLE W/ MOUNTING BRACKET
- 5) MAIN SERVICE WIRE CHASE W/ ELECTRICAL & WATER
- 6) ELECTRICAL PANEL BOX
- 7) POWER SWITCH TRI-CHANNEL COLD PAN
- 8) POWER SWITCH TACO HEATER W/ LIGHTS
- 9) POWER SWITCH TORTILLA GRIDDLE
- 10) DRY HEAT MAIN POWER SWITCH
- 11) DRY HEAT TEMP DISPLAY / CONTROL PANEL
- 12) REMOVABLE WRAPPER BIN
- 13) REMOVABLE SOUR CREAM BOOTS
- 14) REMOVABLE UTILITY SHELF
- 15) REMOVABLE MONITOR SHELF
- 16) HORIZONTAL BOTTLE HOLDER
- 17) REMOVABLE WRAPPER SHELF
- 18) WATER SERVICE CONNECTION
- 19) ELECTRICAL SERVICE CONNECTION
- 20) HF CARVING BOARD
- 21) RB CARVING BOARD
- 22) TACO RAIL
- 23) ADD ON BOTTLE HOLDER

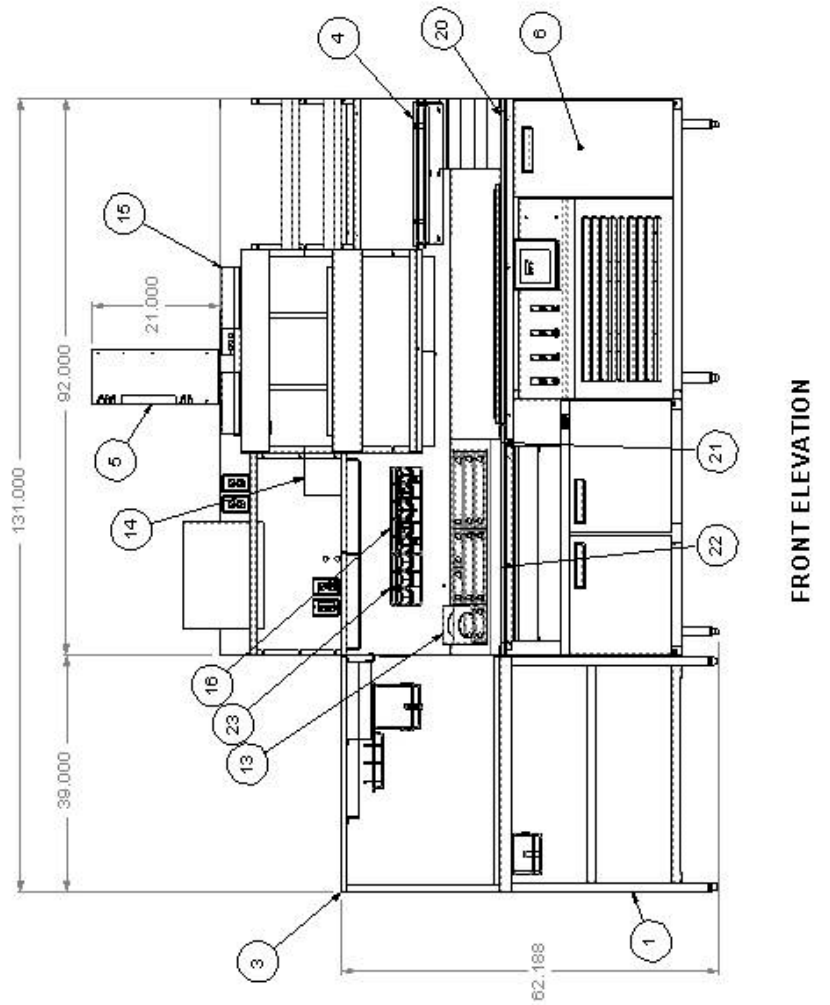
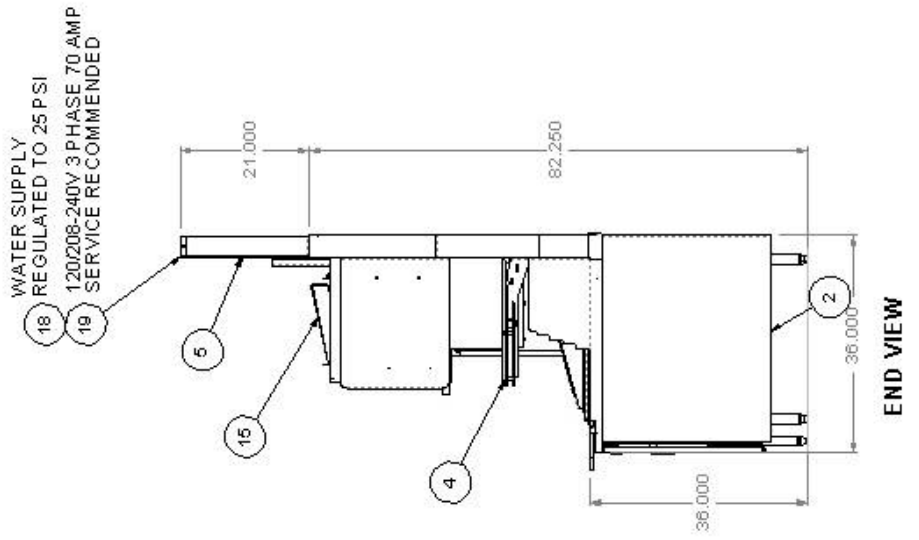

APPLIANCE SET UP

- A) MONITORS
- B) CHEESE MELTER
- C) DIGITAL SCALE

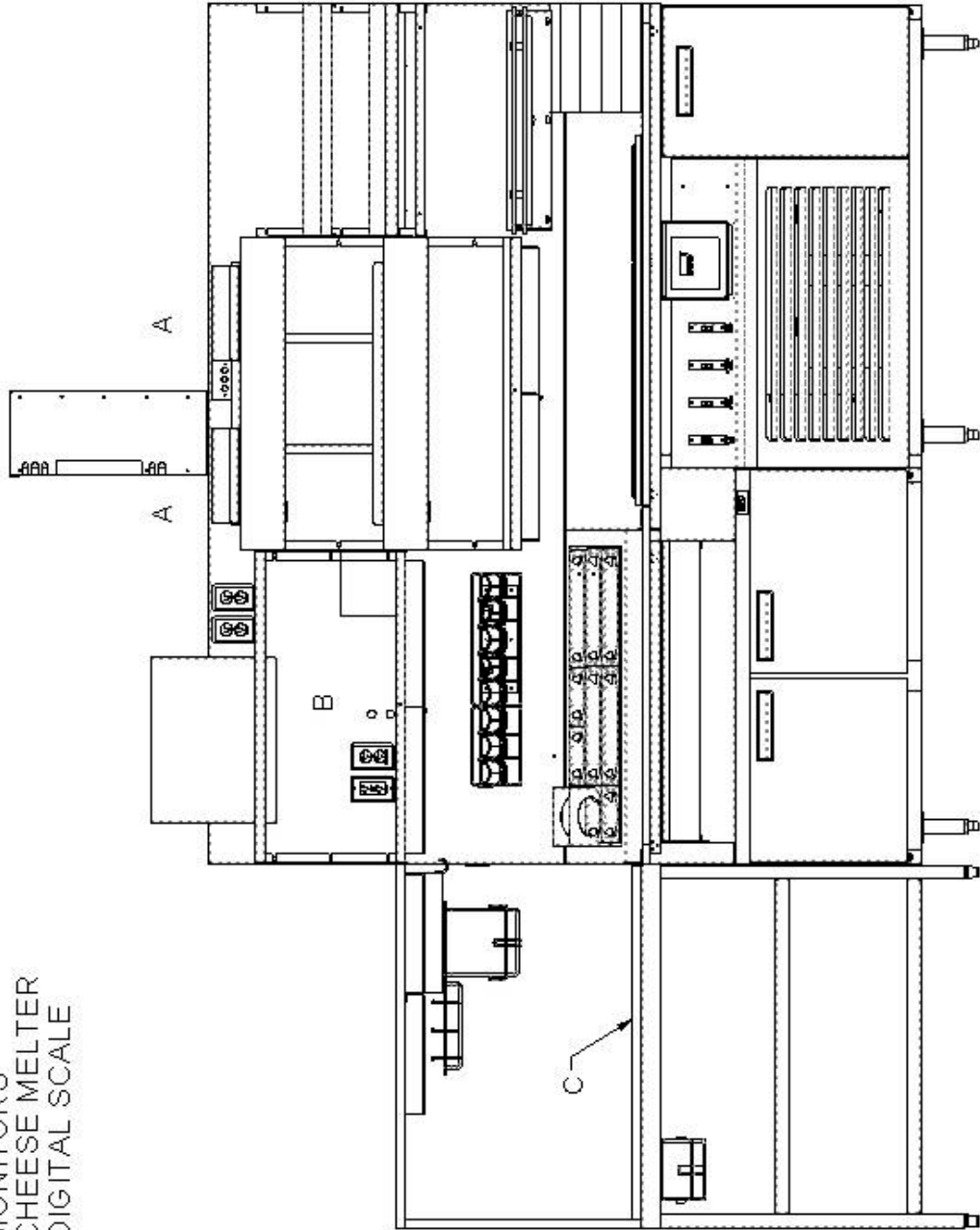

FRONT ELEVATION I-LINE R-L COUNTER

ITEM NO.	QTY.	PART #	DESCRIPTION	DESCRIPTION 2
1	1	212752	Ø1/4" TEE BARBED	
2	2	212754-10	Ø1/4" POLYURETHANE HOSE 10" LENGTH	
3	2	212753	Ø1/4" ELBOW 90°	
4	2	212754-4	Ø1/4" POLYURETHANE HOSE 4" LENGTH	
5	7	212783	CLAMP, HOSE WORM GEAR 7/32" - 5/16"	

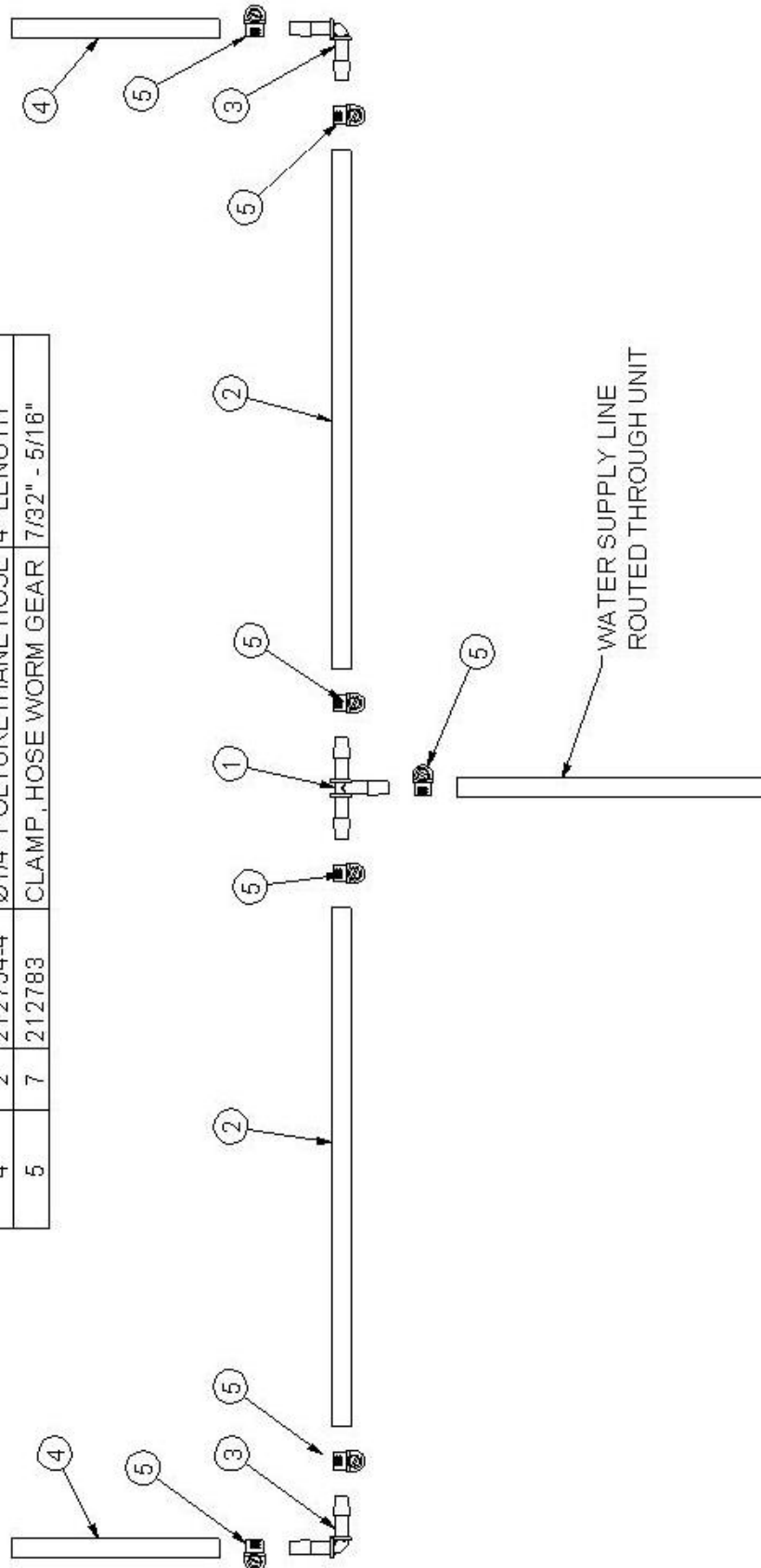

FIELD ASSEMBLY OF I-LINE CHEESE MELTER WATER SUPPLY I-LINE WATER LINE KIT #551044

I-Line Assembly Instructions



STEP A: BASE UNIT SET UP

1. Place Refrigerated Base Unit (Fig. 59) and Extension Table (Fig. 60) in approximate location in store. Leave Refrigerated Base Unit out away from the wall at this time.
2. Remove bolts holding back panel to wall assembly and remove panel (Fig. 61).
3. Slide Extension Table into place and level both units beginning with the Refrigerated Base Unit. Start with feet adjusted in (Fig. 62). Tops should line up and be straight and level when complete.
4. Using hardware kit #215673, secure table to Refrigerated Base Unit with (2) screws #213029 (Fig. 63).



Fig. 59



Fig. 60



Fig. 61



Fig. 62



Fig. 63

I-Line Assembly Instructions



STEP B: SHELVING SETUP

1. Set Extension Table shelving in place with tubing legs over blocks on table top. Support shelving in place and secure to cheese melter shelving assembly using (2) screws #213023 (Fig. 64).
2. Secure shelving legs to blocks using (4) screws #213028 (Fig. 65).



Fig. 64



Fig. 65

STEP C: ELECTRICAL CONNECTIONS

1. Set wire chase in place on top of wall section and secure with (4) screws #213028 (Fig. 66).
2. Electrical contractor can route supply line down through wire chase on top of wall assembly, through wall assembly to load center (Fig. 67-68).
3. Remove chase cover and attach braided water supply line to fitting in top of wire chase and ensure water and drain lines are still routed through holes in wall panel into cheese melter shelving area (Fig. 69).
4. Re-attach back wall panel with screws.
5. Unit can now be pushed back against wall and secured. Be sure to re-level units if needed.
6. Re-secure chase cover to wire chase.
7. **NOTE:** Standard electrical service can be provided using Ø1 ½ “ flex conduit. If Ø2” conduit is being used it can be routed through cutouts provided (Fig. 70).



Fig. 66



Fig. 637



Fig. 68



Fig. 69



Fig. 70



I-Line Assembly Instructions

STEP D: CHEESE MELTER WATER LINE SETUP

1. Using Water Line Kit #551044, assemble cheese melter water line hookups per diagram on page 18.
2. Attach water feeds to each fitting on cheese melters (Fig. 71). (2 per double cheese melter).
3. Attach plastic drain line to drain fitting on bottom of cheese melter (Fig. 72).
4. **NOTE: Plumbing contractor is to supply water line to bulkhead fitting in top of wire chase and ensure all water line connections are tight. Duke MFG Co. recommends the installation of a shut off valve at, or prior to, supply connection.**



Fig. 71



Fig. 72

STEP E: MISC. PARTS SETUP

1. All misc. wrapper bins and shelving can be put in place using appliance set up diagram on page 17 as a guide.

CARVING BOARDS, TACO RAIL, AND ADD ON BOTTLE HOLDER

1. Attach carving board brackets to front of unit with supplied #10-24 x 3/4" screws (Fig. 73).
2. Set HF carving board in place in front of the hot food well (Fig. 74).
3. Set RB carving board in place in front of the cold rail (Fig. 75).
4. Set the Taco Rail in place inside the cutout in the carving board (Fig. 76).
5. Attach add on sauce bottle holders to hot well side of the 5-bottle holder.



Fig. 73



Fig. 74



Fig. 75



Fig. 76

Introduction



This publication contains information regarding the installation and operation of Taco Bell Dual Line Refrigeration Unit and Taco Bell I-Line Refrigeration Unit. Please read this manual completely before attempting to install and/or operate this equipment.

Serial Number



Always have the serial number of your unit available when calling for parts or service. The serial number is located on the data label inside the refrigerated base of the unit

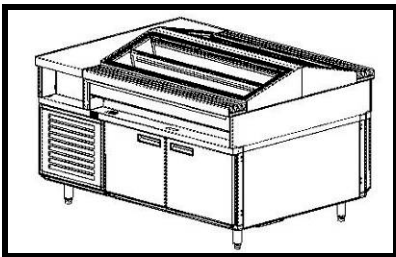

Dual Line Refrigeration Unit

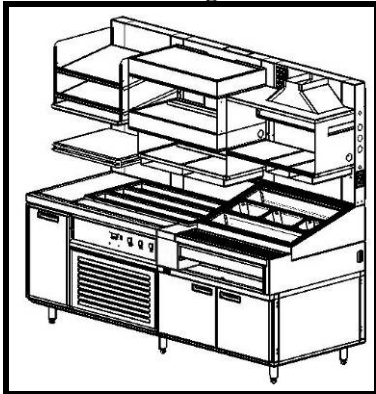

I-Line Refrigeration Unit Left

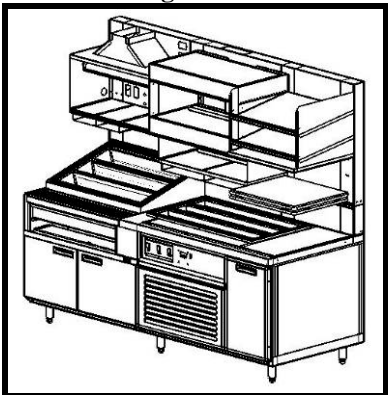

I-Line Refrigeration Unit Right

WARNING

REFER TO THE AMPERAGE DATA LIST IN THE SPECIFICATIONS OR THE SERIAL TAG DATA AND YOUR LOCAL CODE OR THE NATIONAL ELECTRICAL CODE TO BE SURE UNIT IS CONNECTED TO THE PROPER POWER SOURCE. A PROTECTED CIRCUIT OF THE CORRECT VOLTAGE AND AMPERAGE MUST BE RUN FOR CONNECTION OF THE SUPPLY CORD OR PERMANENT CONNECTION TO THE UNIT. THE POWER MUST BE TURNED OFF AND DISCONNECTED WHENEVER PERFORMING MAINTENANCE OR REPAIR FUNCTIONS.

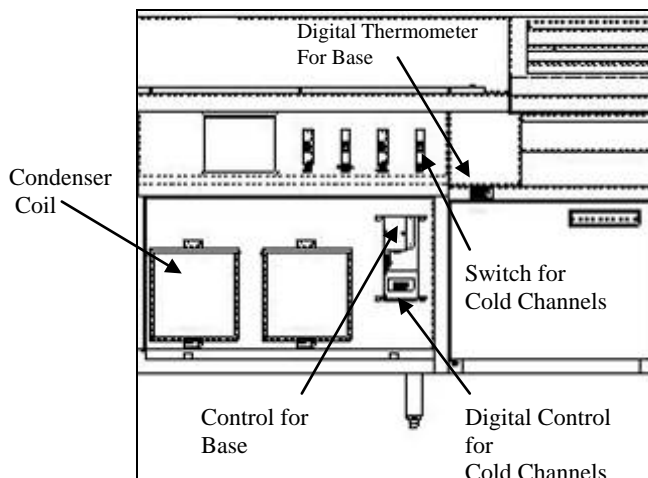

I-Line Location of Controls

Operation



Location of Controls – Dual Line

The refrigerated base ON/OFF control/temperature setting adjustment knob is located behind a louvered door on the walk up side of the line. The ON/OFF switch for the cold channel is located behind the louvered panel on the drive up side of the line.

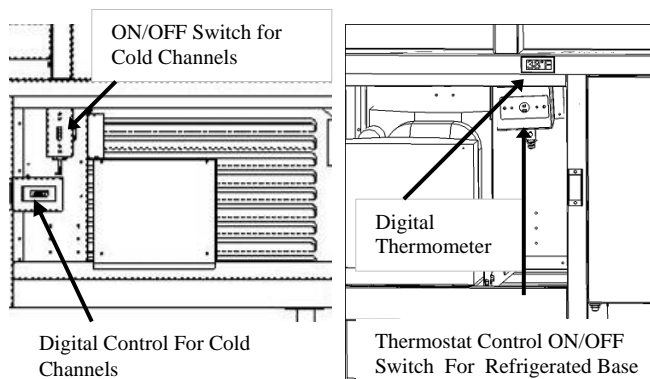

Dual Line Location of Controls

Location of Controls – I-Line

The refrigeration control/temperature setting adjustment knob is located behind the lift-off front access panel. Remove access plate to gain access to the control box for the refrigerated base. The ON/OFF control for the cold channels is located in the control panel above the louvered access panel.

Operating Procedure Refrigerated Base

The desired temperature setting for the refrigerated base is obtained by rotating the adjustment knob. A clockwise turn to the indicated setting will produce required temperatures.

Cold Channel Cold Pans

1. The cold pan needs to be pre-chilled for 30 minutes before product is loaded.
2. The cold pan is design to hold pre-chilled (33°F to 40°F) product. Do not place warm product (above 40°F) in the cold pan as it is not designed to reduce the temperature of the product.
3. Direct air flow from ventilation ducts or fans may hinder performance and increase food temperatures.
4. Turn ON/OFF switch located in control panel on.
5. The temperature control is preset at factory and should only be adjusted by trained service agency.

Maintenance



Stainless Steel Care and Cleaning

To prevent discoloration or rust on stainless steel several important steps need to be taken. Stainless steel contains 70-80% iron which will rust. It also contains 12-30% chromium which forms an invisible passive film over the steel's surface which acts as a shield against corrosion. As long as the protective layer is intact, the metal will not corrode. If the film is broken or contaminated, outside elements can begin to breakdown the steel and begin to form rust or discoloration.

Proper cleaning of stainless steel requires soft cloths or plastic scouring pads.



CAUTION: Never use steel pads, wire brushes or scrapers.

Cleaning should be per Taco Bell Answer System Cleaning Procedure (Book 5).

Cold Pan Cleaning Instructions

1. Unit should be turned off and cleaned daily.
2. Remove product from cold pan.
3. Turn unit off and allow cold pan walls to defrost.
4. Wipe cold pan dry with towel.
5. Clean unit with warm soapy water or mild cleanser.
6. A plastic scouring pad and a mild detergent may be used to remove hardened food.

WARNING

NEVER USE AN ACID BASED CLEANING SOLUTION! MANY FOOD PRODUCTS HAVE AN ACIDIC CONTENT WHICH CAN DETERIORATE THE FINISH. BE SURE TO CLEAN ALL FOOD PRODUCTS FROM ANY STAINLESS STEEL SURFACE. COMMON ITEMS INCLUDE, TOMATOES, PEPPERS AND OTHER VEGETABLES.

WARNING

THE POWER MUST BE TURNED OFF AND DISCONNECTED AT ALL TIMES WHEN PERFORMING MAINTENANCE OR REPAIR FUNCTIONS.

Drain Maintenance - Base

Each unit has a copper drain tube located inside the unit which removes condensation from the evaporator coil and deposits it onto a drain pan where it can evaporate. If you notice excessive water accumulation on the inside of the unit be sure that the drain tube is connected from the evaporator housing to the condensate evaporator drain pan. If water is collecting underneath the unit you may want to check the condensate evaporator drain tube to be sure it is still located above the drain pan. The leveling of the unit is also important as the units are designed to drain properly when on a level surface, if your floor is not level this can also cause drain problems. Be sure the drain pan is kept free of dirt, dust and other debris as excessive amounts will cause water to back up and overflow from the drain pan.

Accessing The Drain Pan – Dual Line

1. Disconnect and isolate the refrigerator from the power source.
2. Open the louvered door and remove the inner panel that does not have the switch (below the digital thermometer).
3. The drain pan is located beneath the condensing unit.

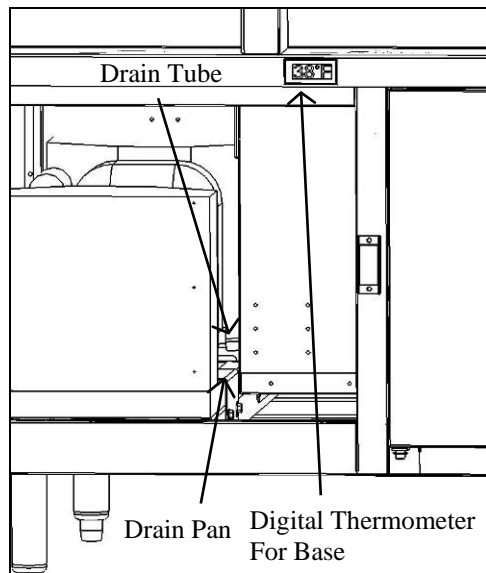

Dual Line Drain Pan Location

Accessing The Drain Pan – I-Line

1. Disconnect and isolate the refrigerator from the power source.
2. Remove the lift off louvered panel.
3. Remove the inner panel.

4. The drain pan is located beneath the condensing unit closest to the refrigerated base.

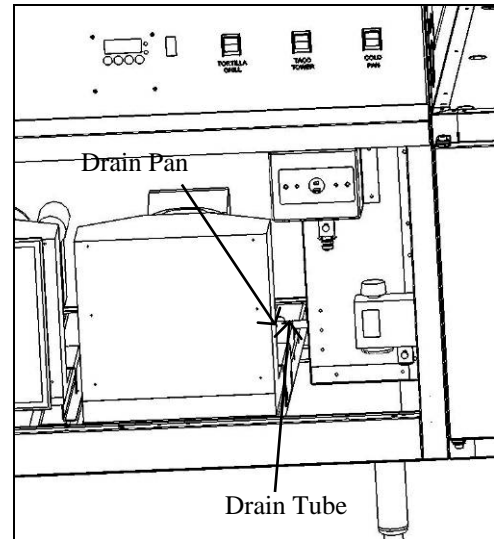

I-Line Drain Pan Location



Wiring Diagrams

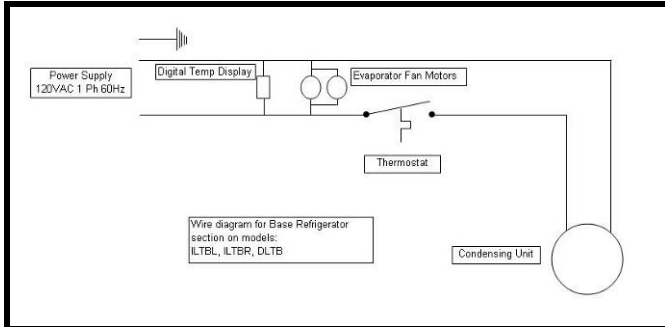

Wiring Diagram for Base Refrigerator

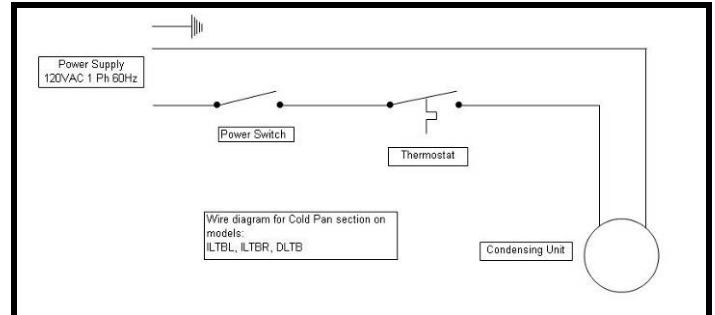

Wiring Diagram for Tri Channel Cold Pan



Trouble Shooting

Trouble Shooting Procedure By Authorized Service Agents

SYMPTOM	CAUSE	REMEDY
Cabinet Too Warm	No electric	Verify power to panel
	Thermostat set too warm	Adjust thermostat setting by following instructions on sticker on control mounting box.
	Faulty thermostat, in the coldest position, the switch is not closed	Replace thermostat
	Doors not sealing	Adjust doors
	Torn or damaged door gaskets	Replace gaskets
	Evaporator fan not running	Check motor, repair or replace
	Condenser fan motor not running	Check motor, repair or replace
	Condenser coil dirty/ filter dirty	Clean coil or filter
Cabinet Too Cold	Thermostat set too cold	Adjust thermostat setting by following instructions on sticker on control mounting box.
	Faulty thermostat, in the off position, the switch does not open, stuck closed	Replace thermostat
Water in the bottom of the unit	Drain tube plugged	Clear drain tube
	Tube not directed into drain pan	Make sure all tubes are directed into drain pan and secured



Service Parts List

ITEM NO.	QTY.	PART #	DESCRIPTION
12	2	550783	ANGLE SUPPORT SCRAP, I-LINE
13	1	550782	PAN SCRAP I-LINE HEMMED
15	1	216675	DIGITAL THERMOMETER
16	2	550276	BOOT SOUR CREAM NESTED
18	1	212340	RECPT, ELEC 5-20 GFCI DUPLEX
19	1	218867	COVER OUTLET GFI SCALES
20	1	551892	CHANNEL FILLER TACO RAIL
21	1	551891	POLY CUTTING BOARD
22	1	551890	POLY CUTTING BOARD
23	1	551894	RAIL ASSEMBLY TACO BELL I-LINE
24	5	551889	BRACKET, CARVING BOARD FRONT
28	1	551916	TOP HOT FOOD RL I-LINE
29	1	551896	ANGLE TACO RAIL SUPPORT I-LINE
30	2	071173	SCREW 1/4 - 20 X 1/2 TPZ-M
31	4	213091	THUMB SCREW, 10-24 X 3/8

TACO BELL I-LINE R-L RB TOP ASSY

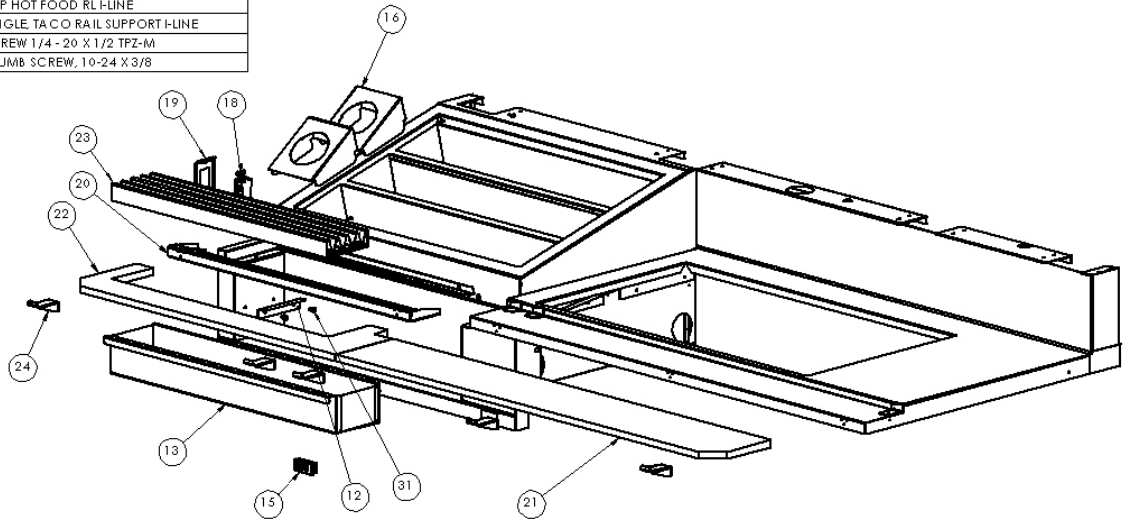

ITEM NO.	QTY.	PART #	DESCRIPTION	DESCRIPTION 2
31	8	212770	PILASTER, SHELF 12" SS	
32	8	212610	SHELF, CLIP	
37	1	216742	WIRE RACK SINGLE 17" OPENING	-
38	1	216743	WIRE RACK SINGLE 19" OPENING	-
53	1	216643	CONTROL TEMP. #RAS-17715	TACO REF.
72	1	216636	GASKET DOOR 19"	
79	1	216645	GASKET DOOR 17"	
112	4	212792	SWITCH TOGGLE 30A RED TOGGLE	
113	4	550902	GUARD TOGGLE SWITCH	TACO BELL
117	1	216837	Thermostat	Breha Digital Display
124	1	071136	UNIT COND. 1/5HP R134A	120V 60HZ
125	1	216879	UNIT COND 120V 60 HZ 1/3 HP	TXV
138	1	216456	KNOB THERMOSTAT SMALL	INCLUDED WITH THERMOSTAT

TACO BELL I-LINE R-L RB ASSY

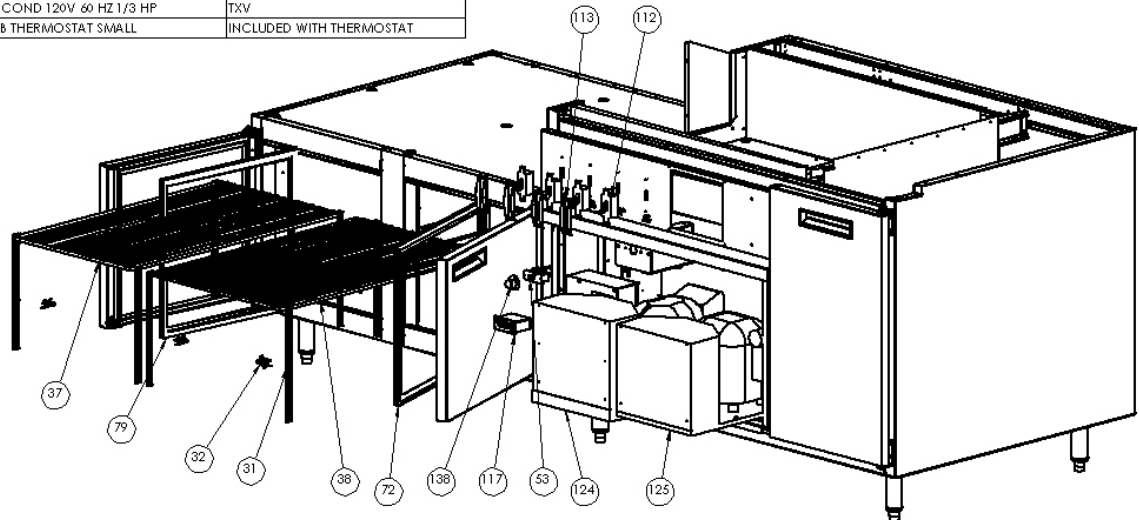



Service Parts List

TACO BELL I-LINE R-L WALL SECTION

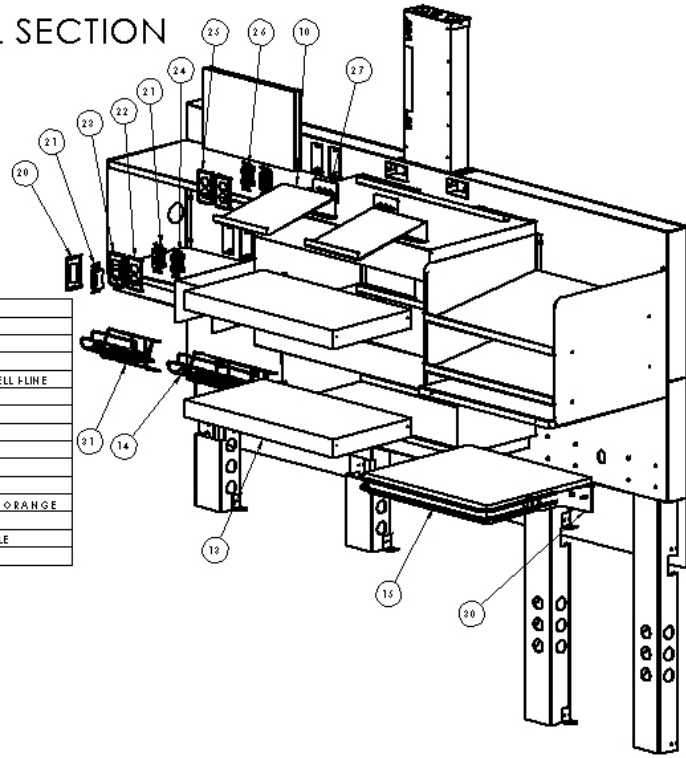

ITEM NO.	QTY.	PART #	DESCRIPTION	DESCRIPTION 2
10	2	550894	SHELF MONITOR	TACO BELL
12	1	216981	HEATER, MATCO	TACO BELL I-LINE
14	1	216982	PROHTO BOTTLE HOLDER #C1082	
15	1	228982	APW ELEC CTRL TORTILLA	GRIDDLE TACO BELL I-LINE
20	1	218860	COVER OUTLET OPEN	
21	2	212240	RECT, ELEC 5-20 GFCI DUPLEX	
22	1	218870	COVER OUTLET MELTER	ETCHED LABEL
23	1	218869	COVER OUTLET GFI STAGER	ETCHED LABEL
24	1	212251	RECT 4-20 250V DUPLEX	
25	2	218884	COVER OUTLET MONITORS	ETCHED LABEL
26	2	212471	RECT 5-15 125V DUPLEX ISOLATED	GROUND COLOR ORANGE
27	2	550918	COVER PLATE	8 HOLES
28	1	551622	GRIDDLE BRACKET	FOR I-LINE GRIDDLE
21	1	216998	PROHTO BOTTLE HOLDER #C1772	

TACO BELL I-LINE R-L TABLE AND COUNTER

ITEM NO.	QTY.	PART #	DESCRIPTION	DESCRIPTION 2
6	1	551404	STEP SHELF ASSY	TACO BELL
8	1	218880	ASSY, DISPLAY CNTL BRD	DRY CHANNEL
ITEM NO.	QTY.	PART #	DESCRIPTION	DESCRIPTION 2
20	1	551641	ASSY, WRAP SHELF	I-LINE R-L TACO BELL
21	1	228928	ASSY, WRAP SHELF I-LINE RL	BAG HOLDER
22	1	228927	ASSY, TABLE BAG HOLDER	TACO BELL
23	1	551634	PAN SCALE	TACO BELL

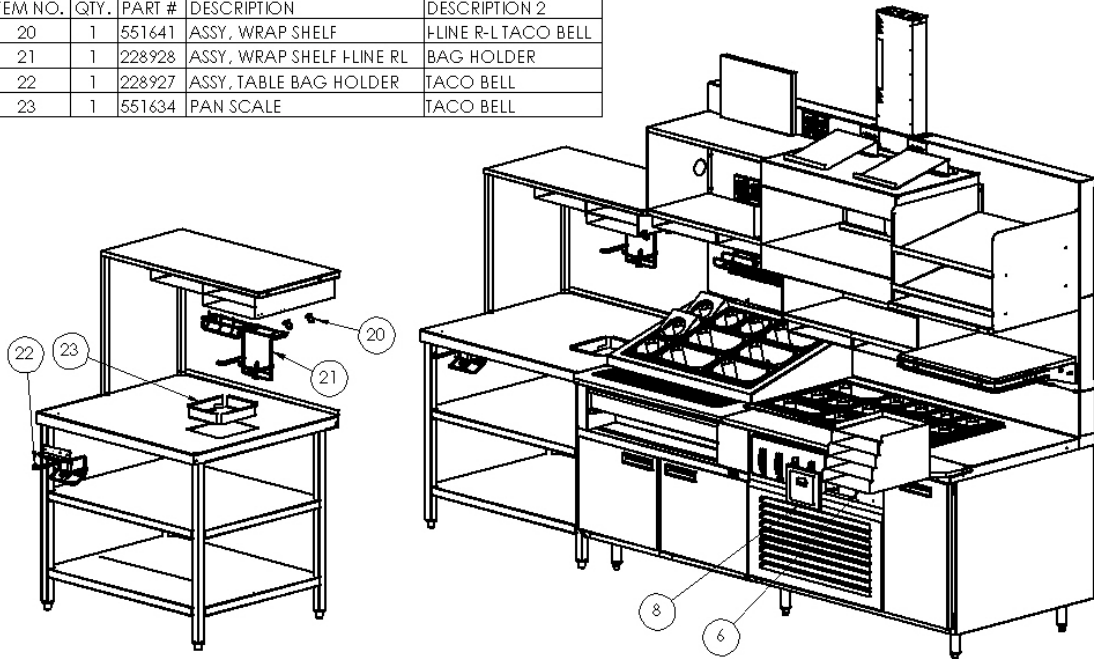



Service Parts List

TACO BELL DUAL LINE RB

ITEM NO.	QTY.	PART #	DESCRIPTION	DESCRIPTION 2
27	16	212770	PILASTER, SHELF 12" SS	
28	16	212610	SHELF, CLIP	
31	32	213091	THUMB SCREW, 10-24 X 3/8	
37	2	216737	WIRE RACK DUAL 19" OPENING	NARROW BASE
38	2	216736	WIRE RACK DUAL 17" OPENING	NARROW BASE
77	1	71136	UNIT COND. 1/5HP R134A	120V 60HZ
78	1	216879	UNIT COND 120V 60 HZ 1/3 HP	TXV
90	2	216636	GASKET DOOR 19"	
96	2	216645	GASKET DOOR 17"	
151	4	551071	ANGLE SUPPORT SCRAP DUAL	TACO BELL
152	2	551974	RAIL TACO NARROW TACO BELL	DUAL W/ CARVING B O
154	1	216675	DIGITAL THERMOMETER	DIXELL # XT11S 110V
155	2	551075	SCRAP TRAY ANGLED	TACO BELL DUAL
161	2	550245	HOLDER SOUR CREAM	TACO BELL
162	2	551965	CHANNEL FILLER TACO RAIL	DUAL TB RETRO 09
163	2	551970	POLY CUTTING B OARD	NEW DUAL RB
164	6	551969	B RACKET, CARVING B OARD FRONT	-
169	2	551971	ANGLE, TACO RAIL SUPPORT	TB RETRO 09 PRODUCTI

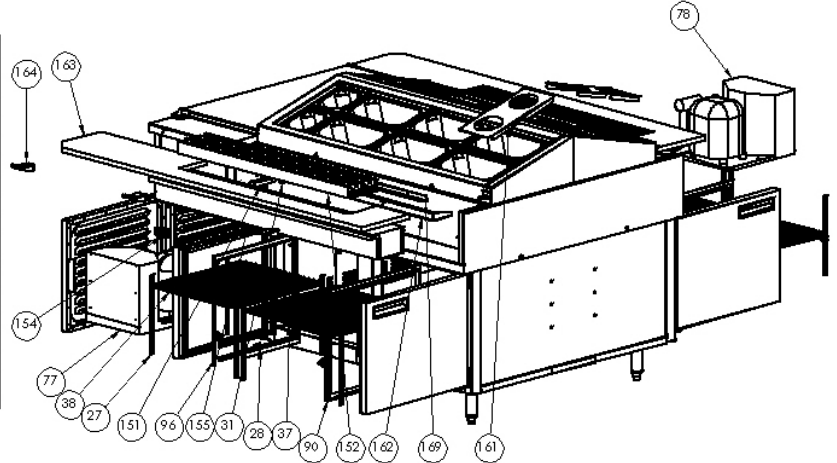

TACO BELL DUAL EXT TABLE

ITEM NO.	QTY.	PART #	DESCRIPTION	DESCRIPTION 2
17	2	228927	ASSY, TABLE BAG HOLDER	TACO BELL
29	2	551634	PAN SCALE	TACO BELL

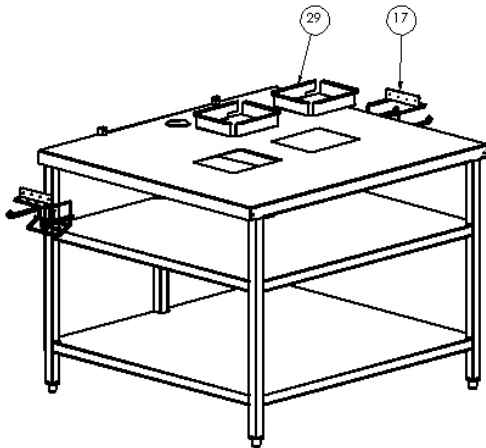

TACO BELL DUAL HF TABLE

ITEM NO.	QTY.	PART #	DESCRIPTION	DESCRIPTION 2
22	2	212792	SWITCH TOGGLE 30A RED TOGGLE	
23	2	550902	GUARD TOGGLE SWITCH	TACO BELL
33	1	218880	ASSY, DISPLAY CNTL BRD	DRY CHANNEL
40	2	551981	POLY CUTTING B OARD	NEW DUAL HF
43	4	551969	B RACKET, CARVING B OARD FRONT	-

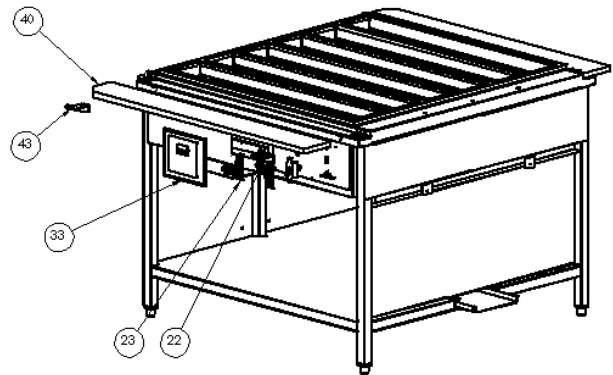



Service Parts List

TACO BELL DUAL OVERHEAD SHELVING

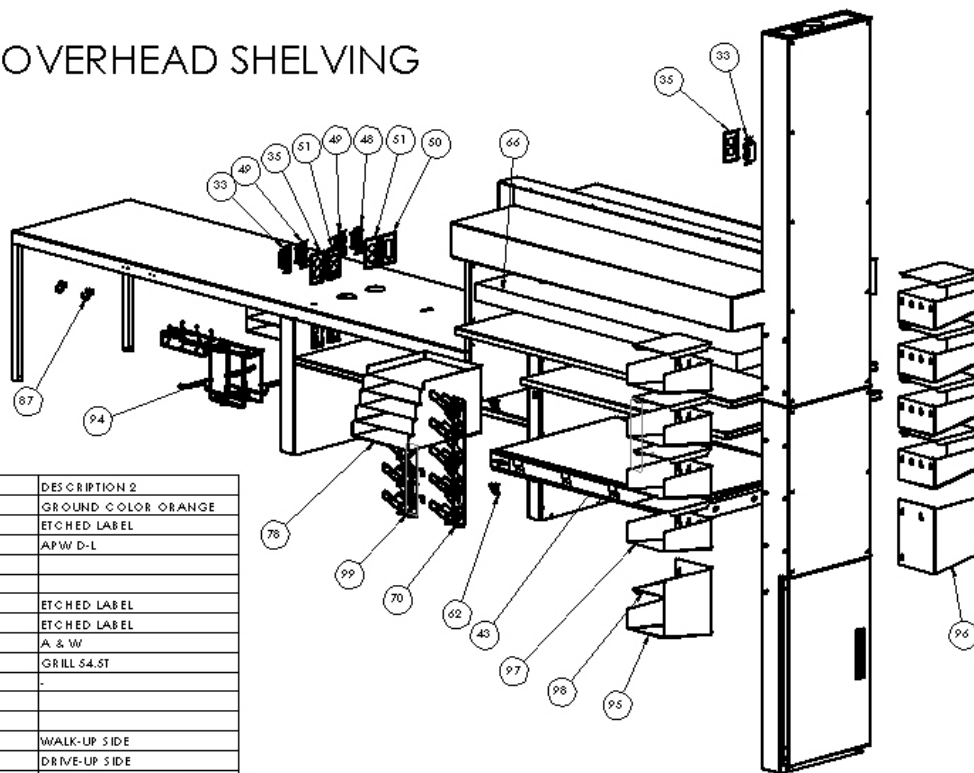

ITEM NO.	QTY.	PART #	DESCRIPTION	DESCRIPTION 2
33	2	212471	RECPT 5-15 125V DUPLEX ISOLATED	GROUND COLOR ORANGE
35	2	218884	COVER OUTLET MONITORS	ETCHED LABEL
43	1	216992	TORTILLA GRILL	APW D-L
48	1	212372	RECPT, ELEC 5-15 GFCI DUPLEX	
49	2	212351	RECPT 6-20 250V DUPLEX	
50	1	218869	COVER OUTLET GFI STAGER	ETCHED LABEL
51	2	218870	COVER OUTLET MELTER	ETCHED LABEL
62	4	551272	BRACKET BOTTLE MOUNT	A & W
66	1	216984	HEATER GRILL 120/208V	GRILL 54.5T
70	2	216986	BACK BOTTLE VERTICAL	-
78	2	551404	ASSY, STEP SHELF	
87	4	212790	J-HOOK SMALL	
95	1	551301	HANGING BIN DEEP WK	WALK-UP SIDE
96	1	551302	HANGING BIN DEEP DU	DRIVE-UP SIDE
97	8	551300	HANGING BIN SHORT	TACO BELL DUAL LINE
98	10	551303	HANGING BIN LID	DUAL LINE UP
99	2	216998	BACK BOTTLE VERTICAL	3 HOLDERS

Notes





For information or technical assistance, call:

TOLL FREE

(800) 735-DUKE (3853)

or

(314) 231-1130