



*Your Solutions Partner*

# **MAINTENANCE MANUAL**

**MAINTENANCE BY QUALIFIED,  
TRAINED PERSONNEL ONLY**

## **PROOFER OVEN WITH TOUCH SCREEN CONTROLS (TSC)**

**Models:  
TSC-6/18M    TSC-3/9M**

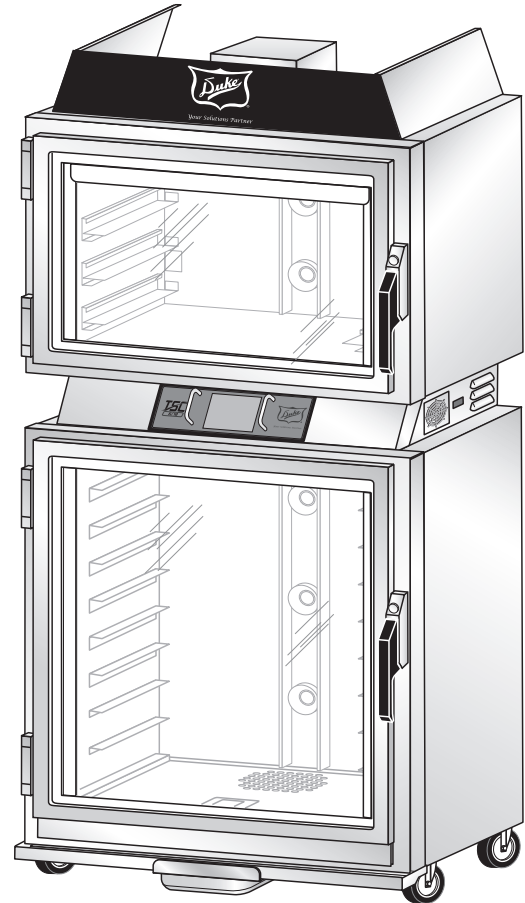

**IMPORTANT INFORMATION, READ BEFORE USE.  
PLEASE SAVE THESE INSTRUCTIONS.**

---

*This manual is Copyright © 2013 Duke Manufacturing Company. All rights reserved.  
Reproduction without written permission is prohibited. Duke is a registered  
trademark of the Duke Manufacturing Company.*

### **Duke Manufacturing Company**

**2305 N. Broadway  
St. Louis, MO 63102  
Phone: 314-231-1130  
Toll Free: 1-800-735-3853  
Fax: 314-231-5074  
www.dukemfg.com**

---

**P/N 120086  
REV E 6/8/2017**



## TABLE OF CONTENTS

IMPORTANT SAFETY INSTRUCTIONS .....	4
OVEN/PROOFER START-UP .....	6
PROGRAMMING CONTROLS.....	7
CARE AND CLEANING.....	10
DOOR ADJUSTMENTS AND GASKET MAINTENANCE .....	14
TROUBLESHOOTING .....	21
PARTS LIST AND ILLUSTRATIONS.....	22
WIRING DIAGRAM .....	25

## IMPORTANT SAFETY INSTRUCTIONS

Throughout this manual, you will find the following safety words and symbols that signify important safety issues with regards to operating or maintaining the equipment.



Indicates a hazardous situation which, if not avoided, could result in death or serious injury.



Indicates a hazardous situation which, if not avoided, could result in minor or moderate injury.



Indicates Important Information



Indicates electrical shock hazard which, if not avoided, could result in death or serious injury and/or equipment damage.



Indicates hot surface which, if not avoided, could result in minor or moderate injury. Specifically, risk of burn from heating elements.



Indicates rotating fan blade hazard which, if not avoided, could result in minor or moderate injury.



Indicates hot surface which, if not avoided, could result in minor or moderate injury.

In addition to the warnings and cautions in this manual, use the following guidelines for safe operation of the unit.

- Read all instructions before using equipment.
- Do not attempt to defeat the grounded connector.
- Install or locate the equipment only for its intended use as described in this manual.
- Do not use corrosive chemicals, water jet equipment, or other pressurized liquid spraying equipment to clean this unit.
- This equipment should be serviced by qualified personnel only. Contact the nearest Duke authorized service facility for adjustment or repair.
- Do not block any openings on the unit.
- A minimum clearance of 6" (152.4 mm) from the top of the unit to the ceiling must be provided.
- Secure unit to a wall with brackets provided to prevent tipping.
- Unit may start operation with inadvertent contact with touch screen display or from other extraneous sources. Turn off all poles mains disconnects should abnormal or unwanted operation occur.

- Install the Restraining Device Kit to prevent damage to main supply connections.
- This appliance can be used by children aged from 8 years and above and persons with reduced physical, sensory or mental capabilities or lack of experience and knowledge if they have been given supervision or instruction concerning use of the appliance in a safe way and understand the hazards involved. Children shall not play with the appliance. Cleaning and user maintenance shall not be made by children without supervision.
- Turn off external mains supply disconnect and allow unit to cool down before servicing or performing maintenance.
- The procedures in this manual may include the use of chemical products. You must read the Material Safety Data Sheets before using any of these products.
- Properly rated all poles mains protection and earthing compliance with local electric codes are required for safe operation of this unit.
- Water supply connections to the unit must comply with local plumbing code and/or standards.
- Disposal of the unit must be in accordance with local environmental codes and/or any other applicable codes.
- **SAVE THESE INSTRUCTIONS**

### Technical Description and Application Notes for TSC Proofer Oven Backflow Preventer Assembly

Check with your local authority having jurisdiction regarding approvals for connecting the Duke TSC Proofer Oven to a potable water supply before making any plumbing connections. Plumbing code requirements vary, but Duke has a kit (P/N [600187](#)) available or installed as a factory option, for backflow prevention to protect water supply systems by preventing the reverse flow of non-potable water into the potable domestic water system. The device consists of two independently acting check valves, internally force-loaded to a normally closed position and designed/constructed to operate under intermittent or continuous pressure conditions.

The two main components of the Duke backflow preventer system are:

- Dual Check Valve type backflow preventer that conforms to ANSI/ASSE standard #1024 and is CSA standard B64.6 certified.
- Inlet water strainer equipped with 100-mesh screen and installed up stream of the backflow preventer. The screen is conveniently located on the rear panel of the proofer, below the backflow preventer, for easy access during cleaning/replacement.

**Duke Manufacturing Co.**

This equipment is intended to be connected to a potable water supply system under pressure and is to be installed with adequate backflow protection to comply with all applicable federal, state, and local codes.

Water supply pressure for proper operation shall be:  
Minimum 40 PSIG(275 KPa)  
Maximum 65 PSIG(448 KPa)  
measured at water line inlet to the equipment.

If so equipped, regular maintenance is required to replace the water filter cartridge at least once per year, and to clean the inlet water screen at least once per year. Consult state/local codes for any additional requirements.

**INSTALLATION OF WATER FILTER**

Install new filter by removing sanitary cap from top of cartridge, insure two black O-rings are in place, then lift up into filter head and rotate cartridge 1/4 turn counter clockwise until it comes to a complete stop. Flush 2 gallons (7.5 Liters) of water through the new filter before using proofer to purge air from filter. Remove hose from bottom of proofer by loosening the compression nut at the disconnect fitting and pull hose out. Place hose over container and turn on water. It will take a minute for the filter to fill before water flows out of hose into container. Once filter is flushed with 2 gallons (7.5 Liters) of water, turn off water supply again, insert hose into water line disconnect, tighten compression nut and turn water supply on again. Check for leaks at connection fittings.

Patent(s) Pending

512776 D

## PROOFER OVEN START-UP



**WARNING**

**ELECTRICAL SHOCK HAZARD.**

**DISCONNECT POWER TO SERVICE UNIT.**

**TASKS MUST BE PERFORMED BY A QUALIFIED SERVICE TECHNICIAN OR ELECTRICIAN.**

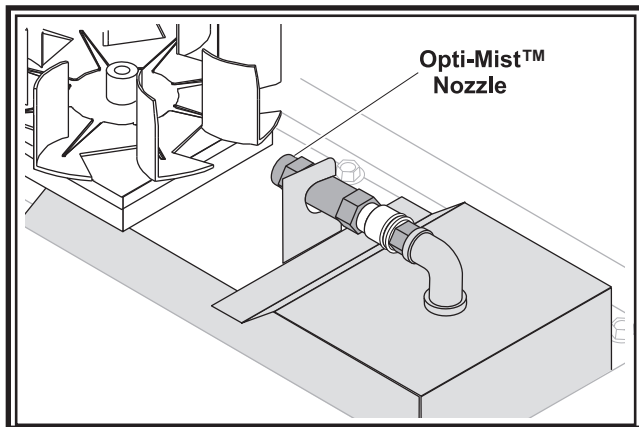

1. Remove Proofer bottom panel and verify that the Opti-Mist™ nozzle is clear of obstructions.



**Figure: Opti-Mist™**

2. Check the door seals and make sure both doors close completely.
3. Have a qualified service technician or electrician connect the oven to the power supply.
4. Turn power on to the unit with the power switch on the left side of the unit. Boot Screen is displayed and automatically transitions to the Main Screen.

5. Turn the oven and proofer ON by touching

the  and  buttons located at the left of the touch screen. The Oven, Proofer and Recipe Buttons will turn to BLUE background. The Oven and Proofer lights will turn on and start preheating.



**Figure: Main Screen**

6. Check to make sure that the oven and proofer fans are running.
7. Open the oven door; the oven fan should stop.
8. Close the door; the fan should resume.
9. Allow the oven and proofer to pre-heat for at least 30 minutes. An audible alarm will sound (3 short chirps) when the oven and/or proofer reach the ready state. Your Duke Proofer Oven is now ready to operate.

If there are any problems refer to the Trouble Shooting section of this manual.

## PROGRAMMING CONTROLS

To access the SPECIAL FUNCTIONS, touch  button on the Main Tool Bar.

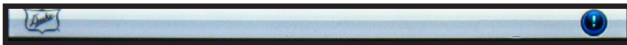





Figure: Main Tool Bar



Figure: Special Functions Screen

### RECIPE EDIT PROGRAMMING INSTRUCTIONS



1. Touch the  button and then enter pin code 5 6 7 8 and Touch the  button when prompted.

2. Touch the button for the recipe you want to edit (i.e. ).

**NOTE:** The 6 oven recipes are listed in the top 3 rows and the 6 proofer recipes are listed in the bottom 3 rows.



FIGURE: Recipe Edit Selection Screen

3. To edit Time, Temperature or Humidity (Proofer Only), touch the  or  button adjacent to the field you want to change. Touch the  button to save the changes.



**NOTE:** You must touch the  button in each field to save the changes you made.











Figure: Recipe Edit Screen

4. To edit the recipe name, touch the  button for the EDIT RECIPE NAME screen.

**NOTE: Typing will add letters/characters to the end of the text.**

**PRESS:**

-  **TO TOGGLE THE KEYBOARD BETWEEN THE UPPER/LOWER CASE CHARACTER SET.**
- ,  AND  **FOR THE NUMBER AND SYMBOL KEYBOARDS.**
-  **TO SPACE**
-  **TO CLEAR ALL TEXT**
-  **TO DELETE/BACKSPACE**

5. Touch the  button to save the changes and return to the RECIPE EDIT Screen. If no changes are required touch the  button to go back to the RECIPE EDIT Screen.





**NOTE: You must touch the  button to save the changes you made.**

6. When complete, touch the  button to go back to the previous screen. Press multiple times to return to the main screen.



**Figure: Edit Recipe Name Screen**

## CONFIG (CONFIGURATION S)

1. Touch the  button and then enter pin code 2 3 4 5 and Touch the  button when prompted.
2. Touch the button for the setting you want to edit.
  - DATE/TIME – Touching will display DATE/TIME edit screen. Touch the  or  button adjacent to the field you want to change. Touch the  button to save the changes.
  - LANGUAGE – Touching will display a list of included languages. Touch the preferred language button to select.
  - C/F SELECT – Touching will toggle between CENTIGRADE MODE ENABLED and FAHRENHEIT MODE ENABLED.
  - DEFAULT RECIPE – Touching will reload factory defaults.
  - SYSTEM STATUS – Touching will display Proofer Oven status.

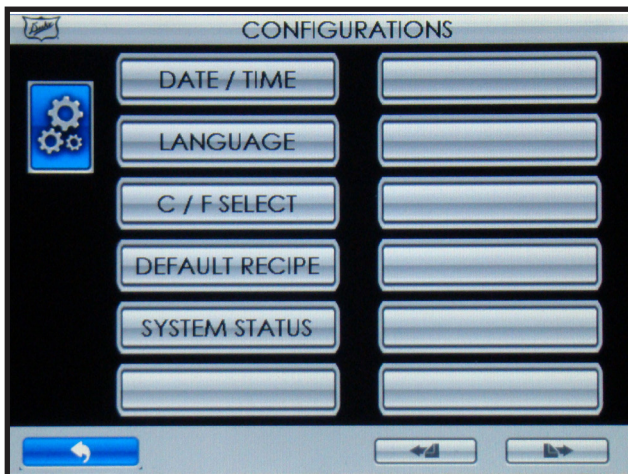



Figure: Configurations Screen

## FILES (FILE MANAGEMENT)

1. Touch the  button and then enter pin code 3 4 5 6 and Touch the  button when prompted.
2. Insert USB drive with the file, until seated, into the USB Host Device.

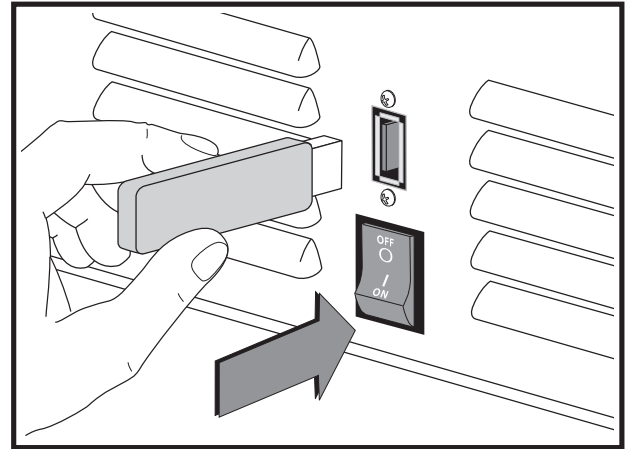

Figure: Inserting USB Drive Into USB Host Device

3. Select file operation from list and follow instruction on the display screen.



Figure: File Management Screen

## CARE AND CLEANING

### **WARNING**

PROOFER OVEN INTERIOR AND RACKS ARE VERY HOT AND COOL SLOWLY.

ALLOW TO COOL BEFORE HANDLING.

### **CAUTION**

ELECTRICAL SHOCK HAZARD.

DO NOT WASH WITH WATER JET OR HOSE.

### **CAUTION**

RISK OF CUT FROM ROTATING FAN BLADE.

DISCONNECT POWER TO SERVICE.

### **CAUTION**

RISK OF BURN FROM HEATING ELEMENTS.

DISCONNECT POWER AND ALLOW TO COOL TO SERVICE.

### **CAUTION**

DO NOT USE OVEN CLEANERS, CAUSTIC CLEANERS, DEGREASERS, ACIDS, AMMONIA PRODUCTS, ABRASIVE CLEANERS, STEEL WOOL, OR ABRASIVE PADS CONTAINING IRON. THESE CAN DAMAGE THE STAINLESS STEEL, DOOR GASKETS AND PLASTIC SURFACES.

### WEEKLY CLEANING INSTRUCTIONS

1. Clean Proofer. Turn the proofer off and allow elements to cool. Remove the bottom panel (remove screw). Remove excess water by wiping it up with a dry cloth. Clean bottom panel to remove any mineral deposits and debris with hot soapy water and follow with clean damp cloth.
2. Clean Opti-Mist proofer spray Nozzle.
  - A. Remove nozzle assembly by depressing latch on quick-connect fitting and pull nozzle out toward fan blade.
  - B. Soak nozzle in plain white vinegar for 4-8 hours to dissolve mineral deposits. Wipe residue from nozzle and rinse in clean water.
  - C. Do not insert objects into nozzle outlet as this can change the water spray performance.
  - D. Replace nozzle assembly if mineral deposits from hard water cannot be removed.
  - E. Reinstall nozzle by inserting into quick-connect fitting until fully seated.

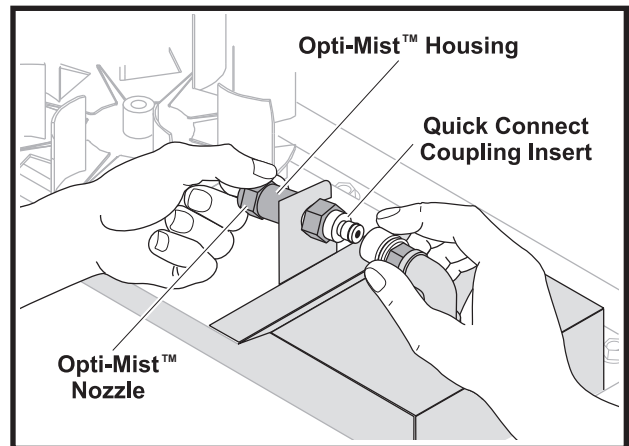

Figure: Opti-Mist™ Quick Connect Nozzle

3. The Cool-Touch door has two window panes. The inner window can be easily separated from the outer window for cleaning. This is achieved by unlatching two clips and rotating the inner window on its hinges. After cleaning, the inner window frame is easily clipped to the outer window by squeezing the two windows together. For additional detail refer to "Cool-Touch Door Information" section of this manual.
4. Inspect oven & proofer door gaskets for cuts, tears or any other damage. Refer to the section on "Door Adjustments and Gasket Maintenance" for directions.

#### Monthly Care and Cleaning Instructions

1. Check door handle screws for tightness.
2. Check the door gasket seal on the Oven and Proofer for leaks. Refer to the section on "Door Adjustments and Gasket Maintenance" for directions.

#### Annual Cleaning Instructions

### **CAUTION**

**HEAVY WATER FILTER CARTRIDGE  
CAN PINCH HANDS.**

**USE CARE WHEN REMOVING.**

### **CAUTION**

**WATER FILTER CARTRIDGE IS  
UNDER PRESSURE, SLOWLY  
REMOVE CARTRIDGE TO RELEASE  
PRESSURE.**

### **CAUTION**

**REPLACE FILTER CARTRIDGE ONLY  
WITH DUKE FACTORY AUTHORIZED  
REPLACEMENT PARTS TO ENSURE  
PROPER OPERATION.**

1. Replace water filter cartridge & clean inlet strainer.
  - A. Turn off water supply to oven.
  - B. Disconnect Wall Brackets if installed. See Installation of wall brackets section of manual.
  - C. Turn off power to Proofer Oven.

- D. Remove old filter by rotating cartridge to the left (facing back of cabinet) slowly until pressure starts to release, stop and let pressure and excess water drain through pressure release hose. Once water has stopped draining, continue turning to the left and pull downward.

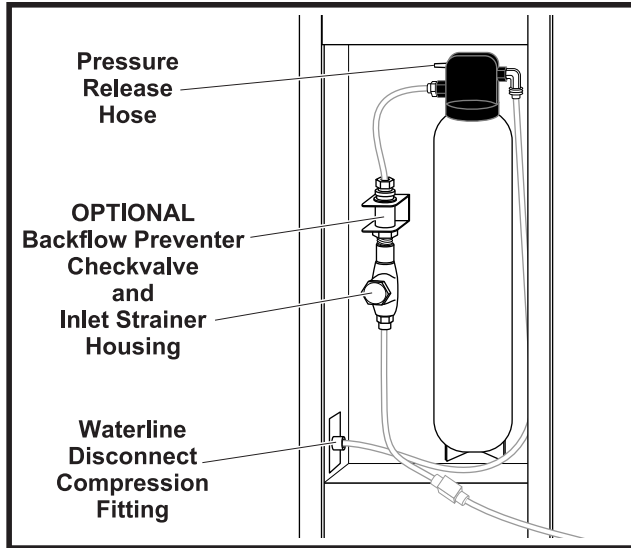

**Figure: Water Filter System**

- E. Install new filter by removing sanitary cap from top of cartridge, ensure two black O rings are in place, then lift up into filter head and rotate cartridge 1/4 turn counter clockwise until it comes to a complete stop.
- F. Remove Inlet Strainer by loosening Hex cap on Inlet strainer Housing.

- G. Remove and flush strainer screen with warm water.

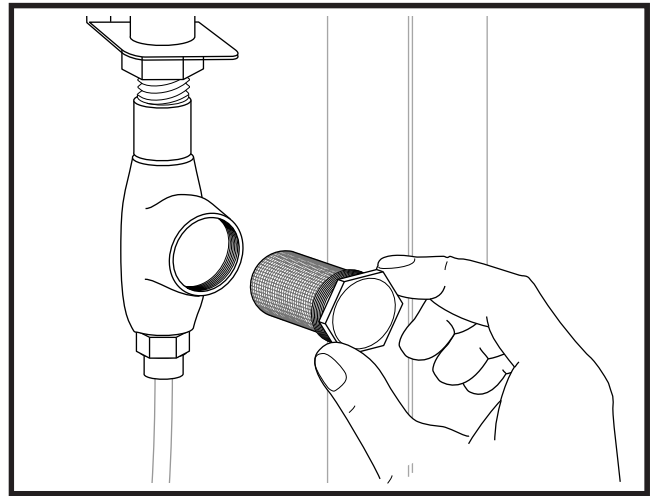

**Figure: Inlet Strainer and Screen**

- H. Replace strainer screen and Hex Cap.
- I. Flush 2 gallons of water through the new filter before using proofer to purge air from filter. Remove hose from bottom of proofer by loosening the compression nut at the disconnect fitting and pull tube out. Place tube over container and turn on water. It will take a minute for the filter to fill before water flows out of the tube into the container.
- J. Once filter is flushed with 2 gallons of water, turn off water supply again, insert tube into water line disconnect, tighten compression nut and turn water supply on again. Check for leaks at connection fittings and Inlet Strainer Housing Hex Cap.
- K. Reconnect Wall Brackets if installed. See **Installation of Wall Brackets** section of Owners manual.

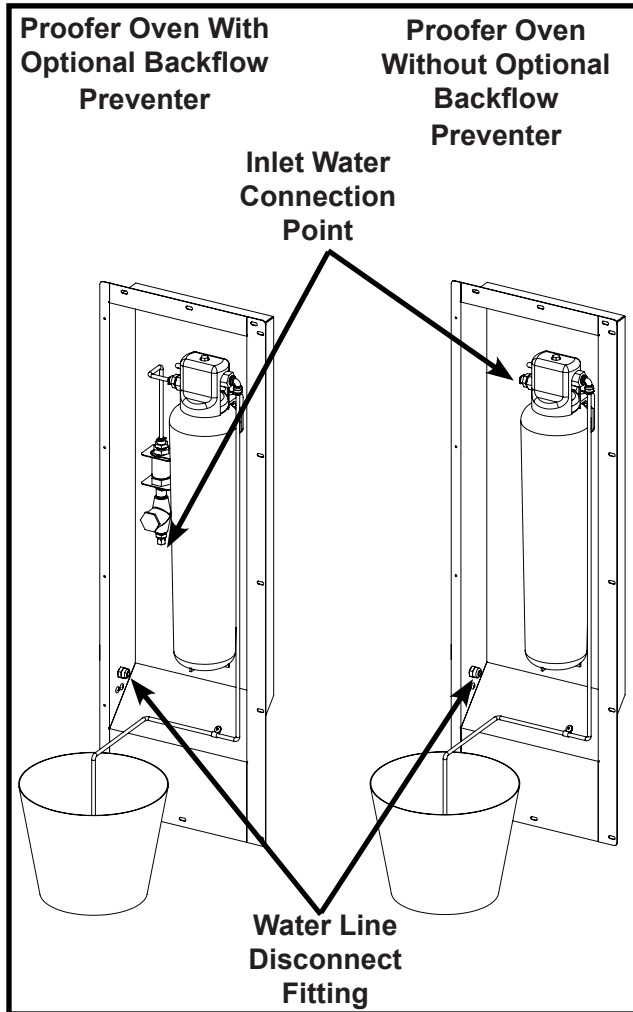
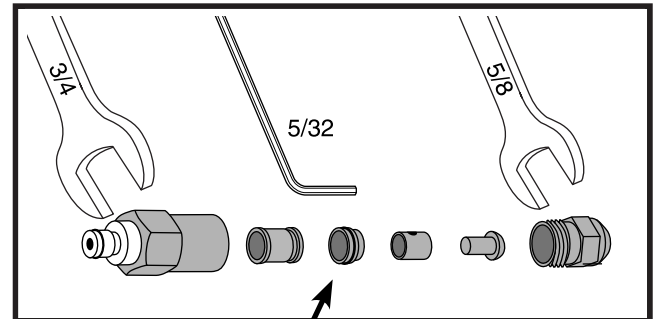

Figure: Water Filter (Flushing 2 gallons of water)

L. Turn on power to Proofer Oven.

**Caution:** Replace filter cartridge only with Duke factory-authorized replacement parts to ensure proper operation. See Parts List section of manual for part number.

2. Clean Opti-Mist™ proofer nozzle screen.
  - A. Remove nozzle assembly by depressing latch on quick-connect fitting and pull nozzle out toward fan blade.
  - B. Use 3/4" and 5/8" wrenches to remove nozzle from body.
  - C. Unscrew filter screen using fingers.
  - D. Use 5/32 allen wrench to remove diffuser retainer, diffuser and centering sleeve.
  - E. Soak all parts in plain white vinegar for 4-8 hours to dissolve mineral deposits. Wipe residue from nozzle and rinse in clean water.
  - F. Do not insert objects into nozzle outlet as this can change the water spray performance.



G. Reassemble nozzle.

Figure: Opti-Mist™ Nozzle Filter

**NOTE:** Ensure proper orientation of the Diffuser Retainer.

- H. Replace nozzle assembly if mineral deposits from hard water cannot be removed.
- I. Reinstall nozzle by inserting into quick-connect fitting until fully seated.

## DOOR ADJUSTMENTS & GASKET MAINTENANCE



### REVERSING OVEN DOOR SWING DIRECTION

1. Remove cover from hinges to expose the screws that hold the hinge to the front of the oven.
2. Remove the hinge screws and door from the oven.
3. Remove the door handle screws, flip the door handle over and replace it on the door.
4. Remove the six screws on the front of the oven to expose the hinge screw holes for the other swing direction.
5. Use the six screws to fill the unused hinge screw holes on the front of the oven.
6. Remove the latch strike plate from the front of the oven and move it to the other side. Use the screws from the other side to fill the screw holes that are no longer used.
7. Position the door on the front of the oven and tighten the hinge screws. Make sure the door is level with the oven body before the screws are tightened permanently.
8. Adjust the door gasket seal.

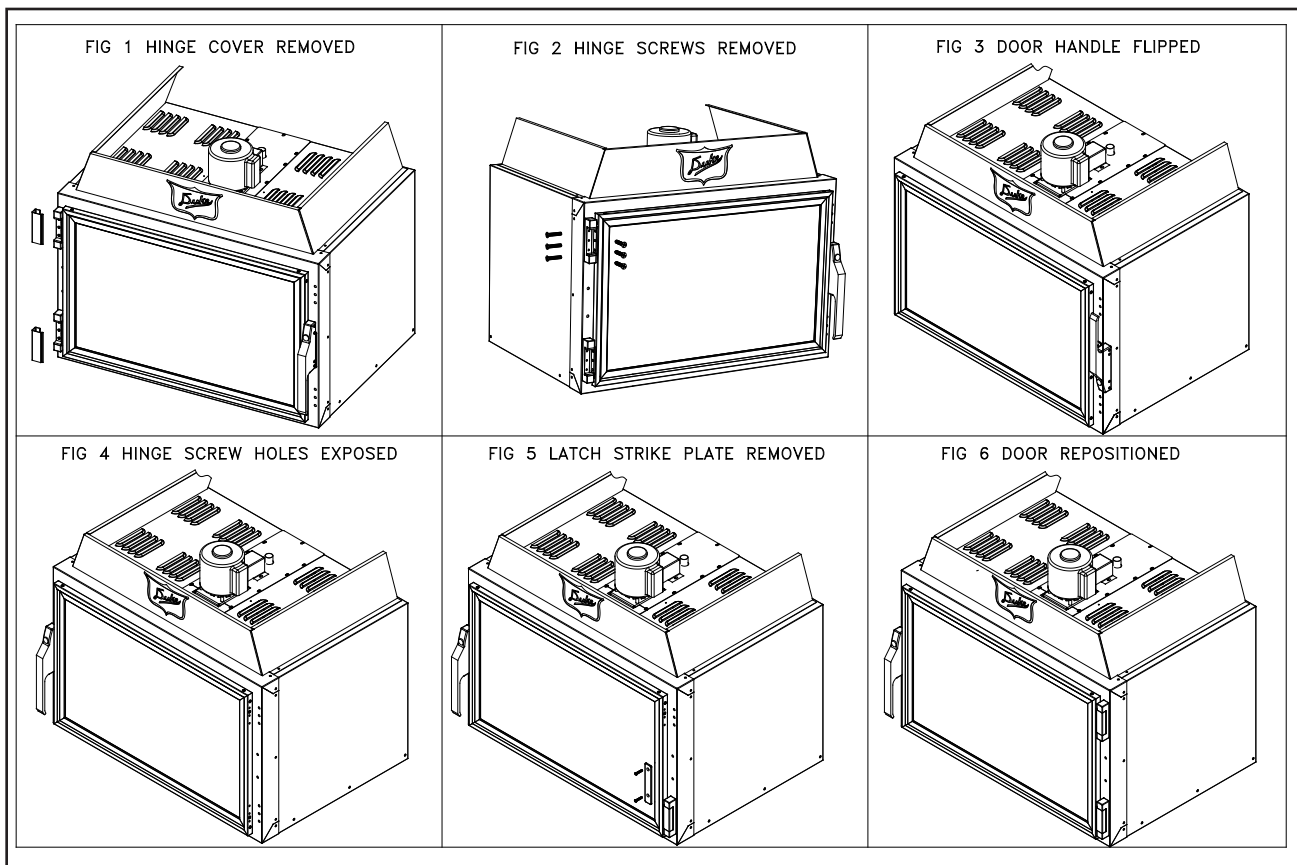
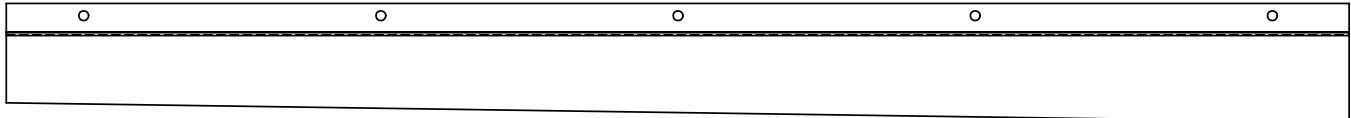

Figure: Illustration – Reversing Oven Door Direction

**Proofer Drip Channel Reversal:**

The proofer door has a sloped drip channel on the bottom that directs any water that drips down the door into the water pan below the door. When the door swing is reversed this drip channel must be replaced with a new channel that has the slope in the proper direction. Contact Duke Manufacturing Service for a new drip channel before changing door swing direction.



**Figure: Right Hinge Drip Channel Slope Towards Right**

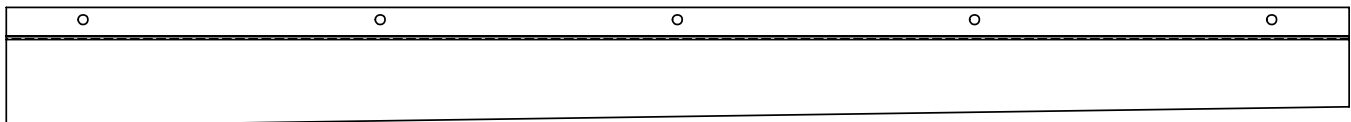

**Figure: Left Hinge Drip Channel Slope Towards Left**

### PROOFER DRIP CHANNEL REVERSAL:

1. Follow the directions for removing the door from the **Reversing Oven Door** section. When the door is off you can then replace the drip channel.
2. Remove the screws that hold the drip channel on and remove the drip channel. Use the same screws to fill the empty holes after the drip channel is off.
3. Locate the new drip channel on the other end of the door. Make sure that the slope is directed to the hinge side of the door.
4. Fasten the drip channel to the door with the self-tapping screws provided with the new drip channel.
5. Follow the directions from the **Reversing Oven Door** section for mounting the door.

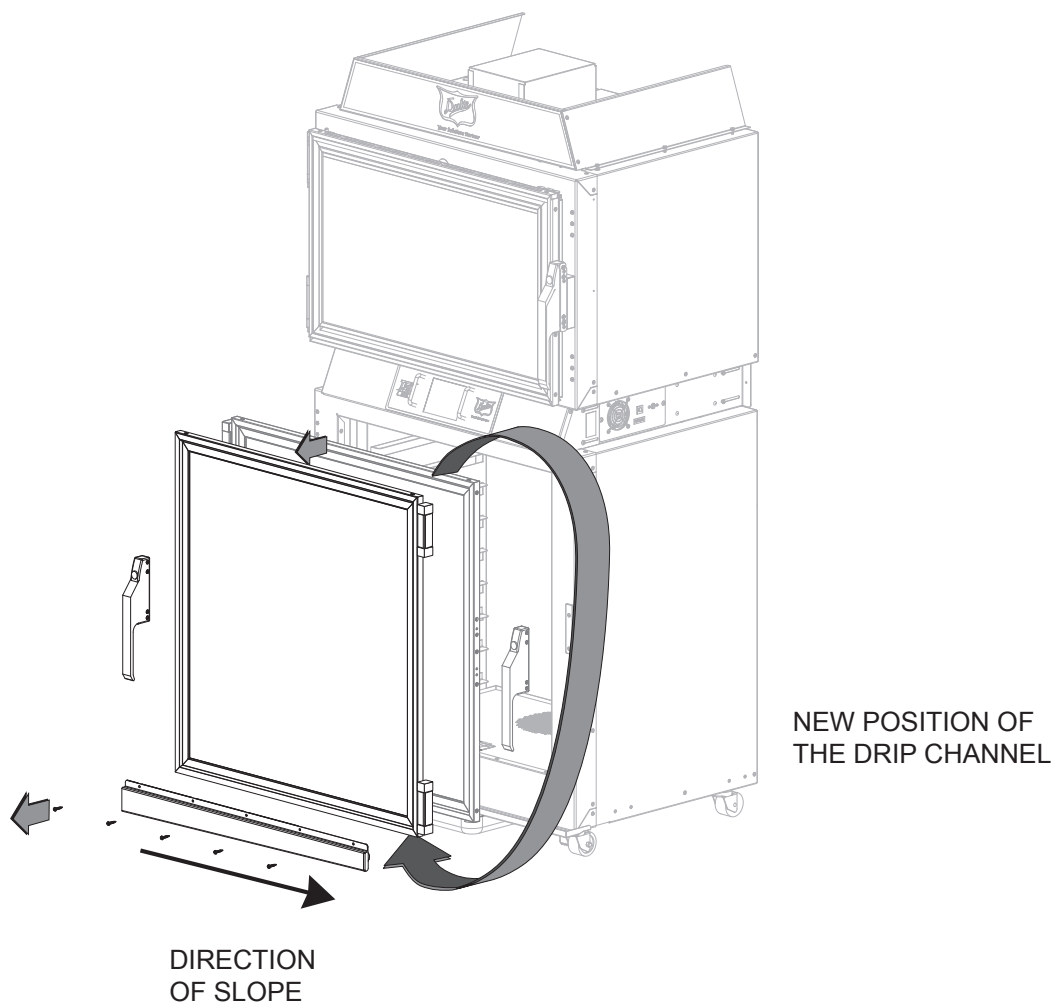

**Figure: Illustration – Reversing Proofer Door Direction**

### DOOR GASKET LEAK ADJUSTMENTS:

The doors should be checked for leaks every three months. The adjustment can be made by following the instructions below. If the door gasket is damaged or compressed permanently, it should be replaced. Call Duke Manufacturing Co. at 800-735-3853 to order a new gasket before making adjustments.

1. To check the adjustment, close the door with a currency bill between the gasket and front of the oven. Resistance should be felt when pulling the currency bill out with the door closed. Do this check in several places and readjust the door as necessary.

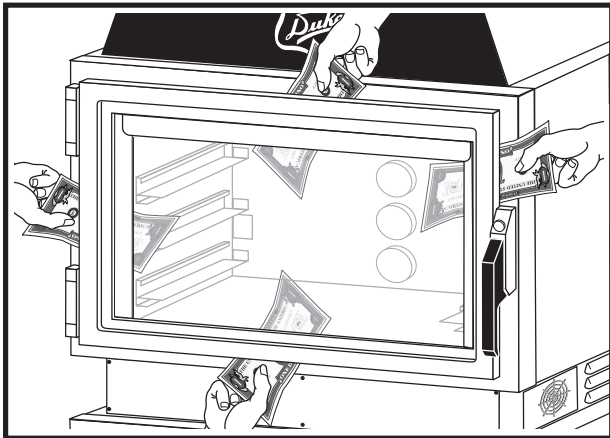

Figure: Gasket Check

2. With the door closed, remove the hinge covers with a screwdriver and loosen the six screws that hold the hinges to the door.

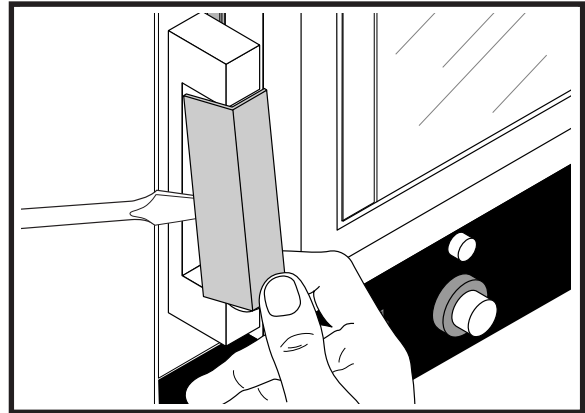

Figure: Removing Hinge Cover

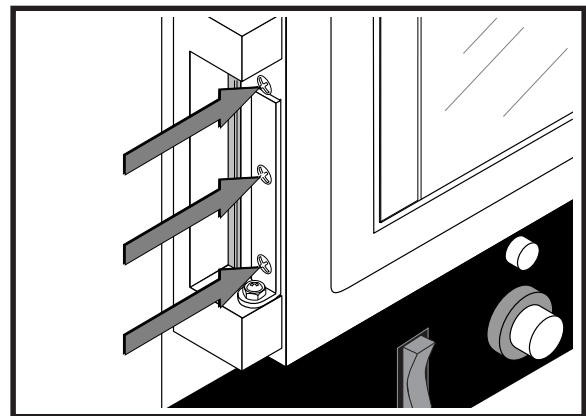

Figure: Location of Hinge Screws

- Adjust the door position by moving the door frame in or out to seal any gaps between the gasket and the oven. Adjustment is made using the screws on the handle and the hinges.

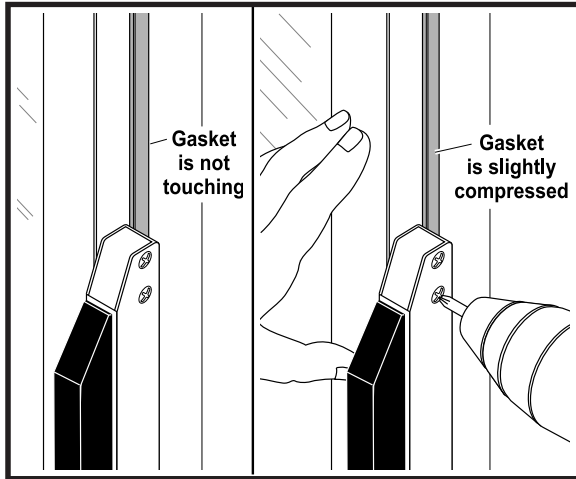

Figure: Handle Side Adjustment

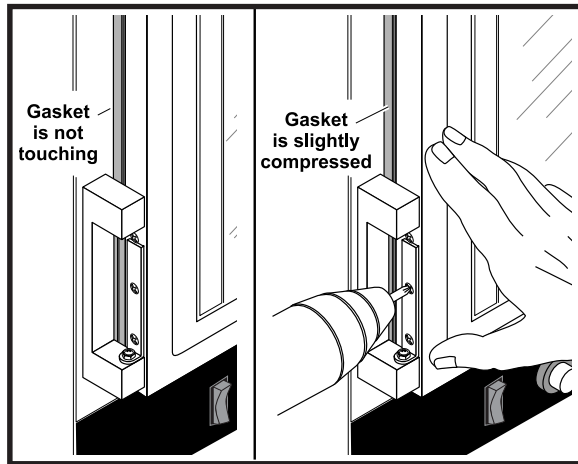

Figure: Hinge Side Adjustment

**IMPORTANT**

Be careful not to compress the gasket too much, or it will not allow the door to be closed.

- To check the adjustment, close the door with a currency bill between the gasket and front of the oven. Resistance should be felt when pulling the currency bill out with the door closed. Do this check in several places and readjust the door if necessary.

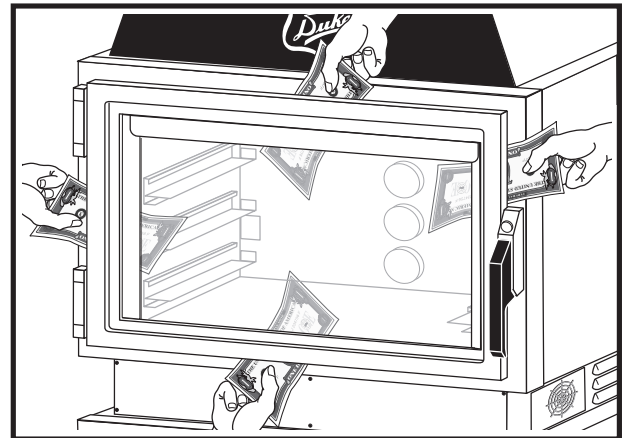

Figure: Gasket Check

**GASKET REPLACEMENT:**

- Remove the old gasket by pulling it out of the groove in the door frame.

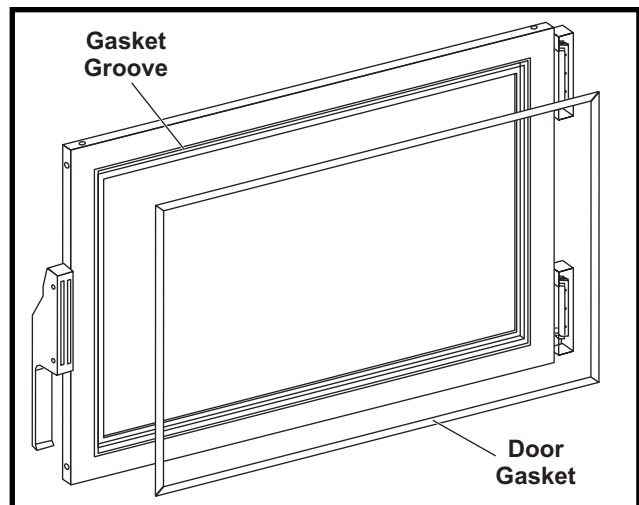
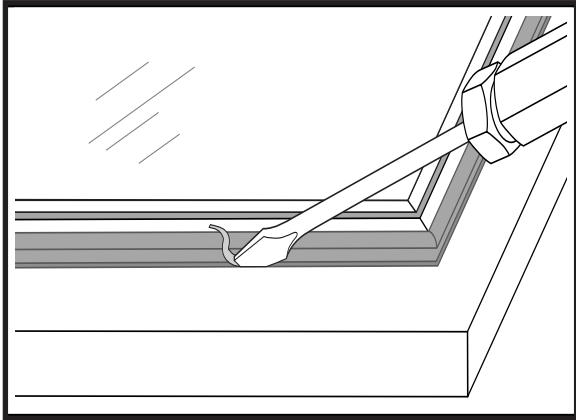

Figure: Door and Gasket

2. Clean the groove with a screwdriver or other flat-bladed tool to remove any dirt or gasket pieces.



**Figure: Cleaning Gasket Groove**

3. Press the new gasket into the groove. Make sure it is fully seated in the groove and flat against the door frame.

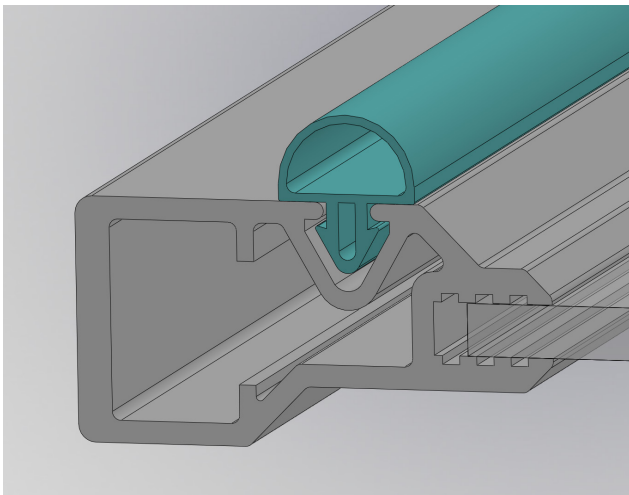
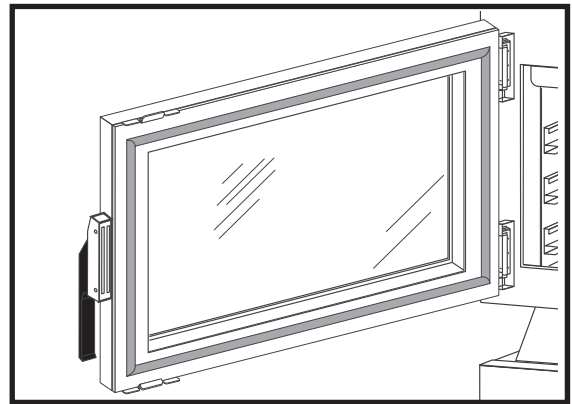

**Figure: Properly Seated Gasket**

4. Check the door adjustment to make sure there are not any leaks. Also, check that the new gasket is not compressed too much, making the door hard to close.

## COOL-TOUCH DOOR INFORMATION AND CLEANING INSTRUCTIONS

The Cool-Touch door has two window panes. The inner window can be easily separated from the outer window for cleaning. This is achieved by unlatching two clips and rotating the inner window on its hinges. After cleaning, the inner window frame is easily clipped to the outer window by squeezing the two windows together.



**Figure: Cool-Touch Door inside view.**

1. To open the windows for cleaning, unlatch the top clip.

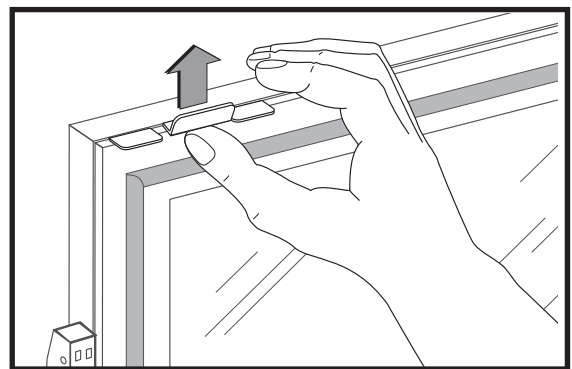

**Figure: Unlatch Top clip**

2. Unlatch the bottom clip.

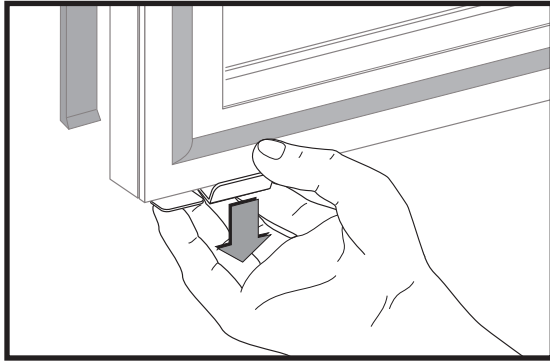

**Figure: Unlatch Bottom Clip**

3. Cool-Touch Door bottom easily swings open for cleaning.

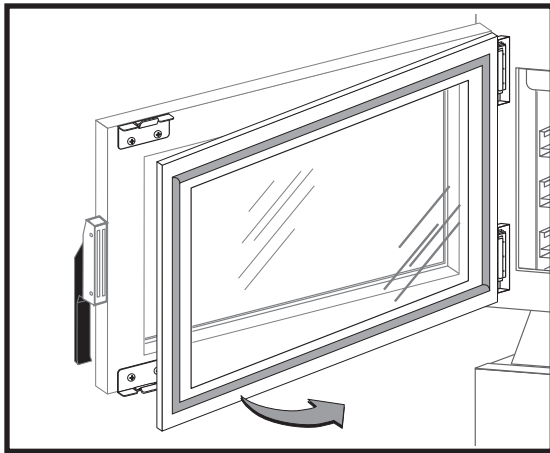

**Figure: Door Swings Open for Cleaning**

4. Cool-Touch inner door is easily clipped to the outer door by squeezing them together.

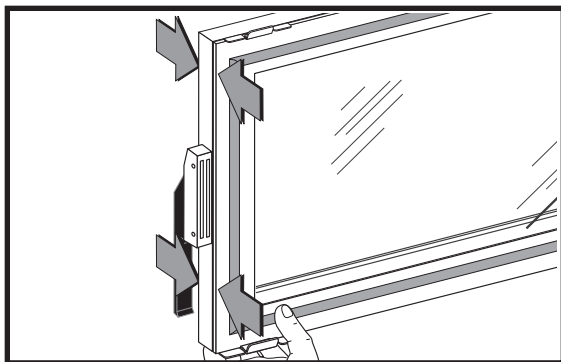

**Figure: Door Clipped Together After Cleaning**

## BULB MOUNTING DETAILS

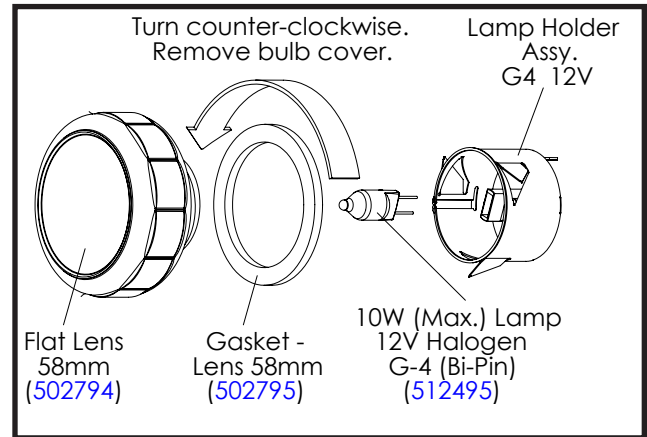

**Figure: Halogen Lamp Assembly**

## CAUTION

**DO NOT TOUCH LIGHT BULBS WITH BARE HANDS AS OIL/ FINGERPRINTS WILL SHORTEN THE LIFE OF THE BULB. USE A CLEAN GLOVE OR CLOTH TO HANDLE BULBS.**

1. Turn the Proofer Oven OFF and allow to cool.
2. Remove the light lens and gasket by turning it counter clockwise.
3. Remove the burned out bulb.
4. Using clean gloves or a cloth, install the new lamp bulb (Halogen Lamp G4, 12 Volts, 10 Watt Maximum) into the lamp holder.
5. Replace light lens and gasket ensuring it is fully seated and tightened or leaks will occur.

## TROUBLESHOOTING

PROBLEM	YES	NO
<p><b>1. Oven does not heat with oven switch in the ON position and Oven Temperature not set at 0°.</b></p> <p>a. Are oven indicator lights on?</p> <p>b. Does Oven Fan work?</p> <p>c. Is Oven Door Securely closed?</p> <p>d. Is Supply Circuit Breaker tripped?</p> <p>e. Does oven work?</p>	<p>Observe Oven Fan. Go to "b".</p> <p>Call Duke Service.</p> <p>Call Duke Service.</p> <p>Reset Circuit Breaker. Try oven again. Go to "e".</p> <p>Troubleshooting complete.</p>	<p>Reset Hi-limit Switch</p> <p>Check Proofer Operation. Go to "d".</p> <p>Close Door securely. Go to "e".</p> <p>Check Fuses on Control Box. Goto "e".</p> <p>Call Duke Service.</p>
<p><b>2. Proofer does not heat with Proofer Switch in the ON position Proofer</b></p> <p>a. Are Proofer indicator lights on?</p> <p>b. Does Proofer Fan appear to work?</p> <p>c. Does Oven work?</p> <p>d. Is Supply Circuit Breaker tripped?</p> <p>e. Does Proofer work?</p>	<p>Observe Proofer Fan. Go to "b".</p> <p>Call Duke Service.</p> <p>Call Duke Service.</p> <p>Reset Circuit Breaker. Try Proofer again. Go to "e".</p> <p>Troubleshooting complete.</p>	<p>Check Oven Operation. Go to "c".</p> <p>Check Oven Operation. Go to "c".</p> <p>Check Supply Circuit Breaker. Go to "d".</p> <p>Check Fuses on Control Panel. Go to "e".</p> <p>Call Duke Service.</p>
<p><b>3. Oven/Proofer lights not working.</b></p> <p>a. Is more than one light not working?</p> <p>b. Do lights work?</p>	<p>Replace inoperative light bulbs and recheck. Go to "b".</p> <p>Troubleshooting complete.</p>	<p>Check transformer. Go to "b".</p> <p>Call Duke Service.</p>
<p><b>4. Proofer Humidity not working/ insufficient with Humidity Control not set to Off.</b></p> <p>a. Does there appear to be a light fog on the Proofer door?</p> <p>b. Does Proofer Fan appear to work?</p> <p>c. Confirm water supply to unit is on.</p> <p>d. Check for restrictions in water line. (Kinks in water line, Clogged filter, inlet strainer or mineral build-up on sprayer nozzle)</p>	<p>Decrease humidity if too much moisture on proofer door. Go to "b".</p> <p>Go to "c".</p> <p>Go to "d".</p> <p>Troubleshooting complete.</p>	<p>Increase humidity if not enough moisture on proofer door. Wait 15 minutes. Go to "b".</p> <p>Call Duke Service</p> <p>Turn water supply on. Go to "d".</p> <p>Call Duke Service.</p>

A Manually reset high temperature safety limit is provided on the right side of the control section of the unit to protect the oven elements. The high limit will not trip under normal operating conditions. Should the oven high limit trip, push the RESET button. The high limit will reset with a "click" if an over temperature trip occurred. If condition persists, call Duke Service.

**HIGH LIMIT PROTECTOR  
FOR OVEN ELEMENTS**

LOADED ON RIGHT SIDE OF  
CONTROLS SECTION

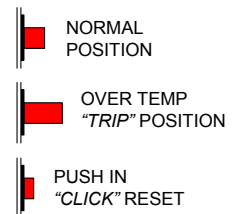

# PARTS LIST AND ILLUSTRATIONS

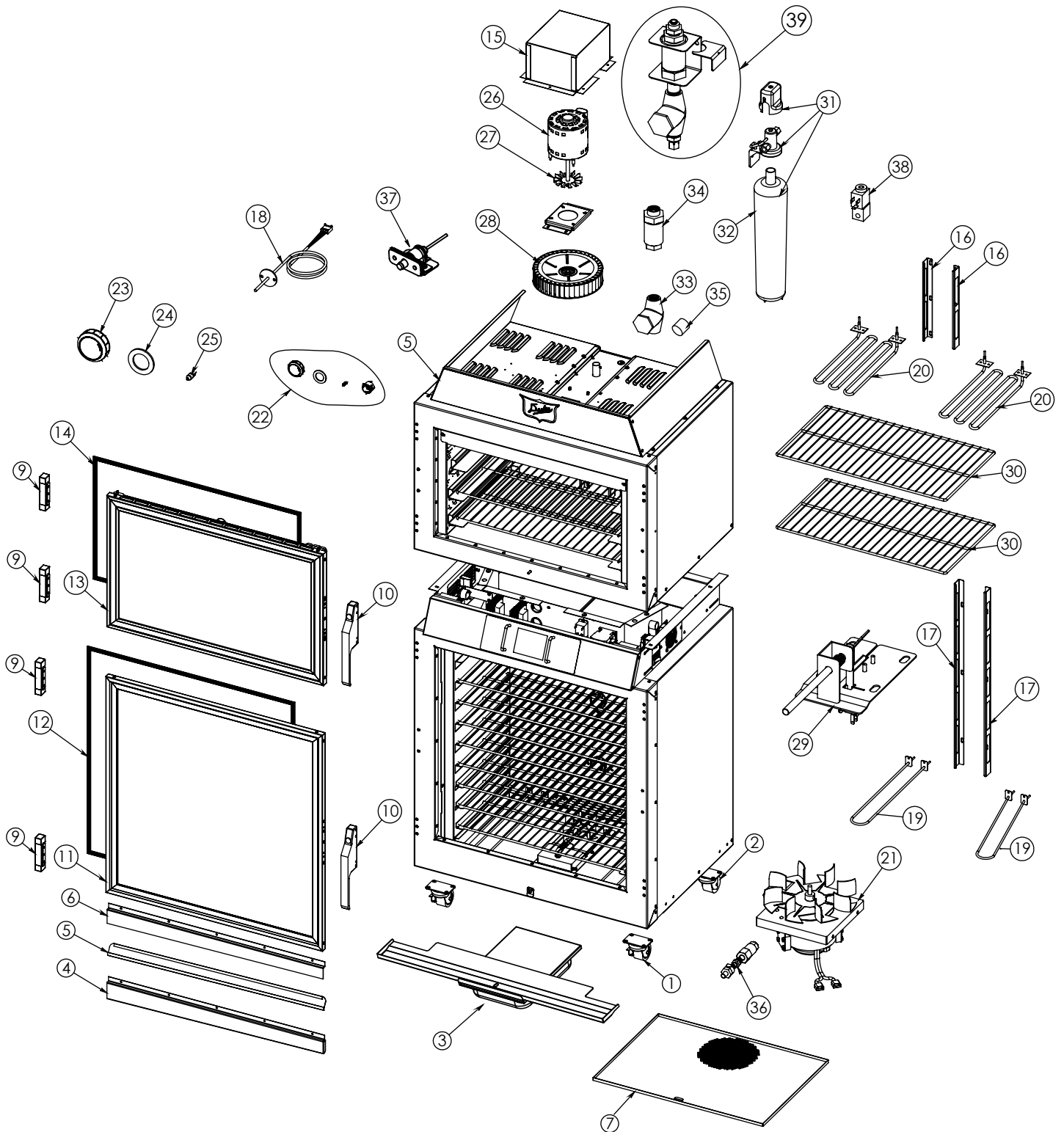

Duke TSC Proofer Oven Exploded View

ITEM #	PART #	DESCRIPTION
1	512836	Caster, swivel
2	512835	Caster, locking w/brake
3	600374	Kit, Drip pan
4	155977	Housing, drip edge – left hinged door
	155979	Housing, drip edge – right hinged door
5	155981	Gutter, drip edge
6	155976	Channel, drip edge – left hinged door
	155978	Channel, drip edge – right hinged door
7	512562	Proofer Bottom Accesses Panel
8*	208750	Screw, Bottom Accesses Panel
9	512817	Hinge, door Oven & Proofer
10	512905	Handle & latch assembly Oven & Proofer
11	512909	Proofer door assembly
12	502861	Gasket, proofer door
13	600164	Oven Air Wash Door assembly
14	502869	Gasket, oven door
15	502180	Cover, Motor
16	502744	Guard, Oven Light
17	502745	Guard, Proofer Light
18	512777	RTD thermostat Oven & Proofer
19	512759	Element, 500W Proofer 208V
	512791	Element, 500W Proofer 230V
20	154373	Element, 2500W Oven 208V
	502831	Element, 2500W Oven 230V
21	512594	Proofer Motor Assembly with Fan
22	502792	Halogen Lamp Complete 10W
23	502794	Lens, Glass Light
24	502795	Gasket, Lens Glass
25	512495	Bulb, 10W Halogen
26	600269	Motor, Oven Single Speed 208/230V 50/60Hz
27	502338	Fan Blade - Oven Motor Heat Slinger
28	154039	Blower Wheel, Oven
29	512814	Switch, Oven Door
30	154547	Wire Rack
31	512539	Water Filter System with Filter
32	512570	Water Filter Only
33	512592	Strainer Assembly (If Installed, Optional)
34	512537	Valve, Backflow Dual Check (If Installed, Optional)
35	512429	Screen, Inlet Strainer 100 Mesh
36	600185	Proofer Nozzle Quick Disconnect Kit
37	120037	Sensor, Relative Humidity
38	512779	Solenoid Valve 50-60 Cycle
39	600187	Backflow Preventer Assembly Kit - Optional
Not Shown	522030	Fan, Muffin, 230CFM, 230V - Used on 50 HZ Models Only

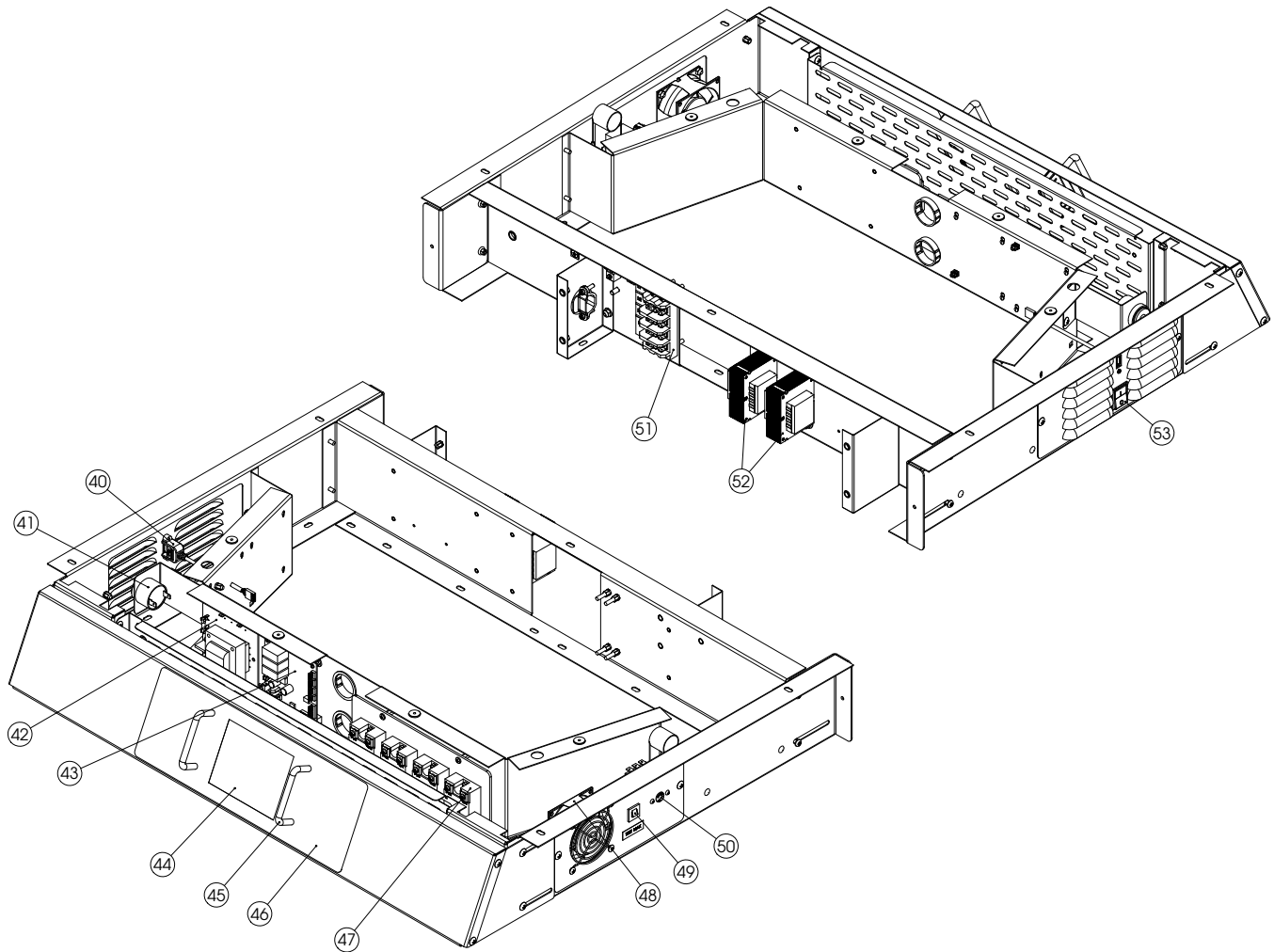

**Control Panel Exploded View**

ITEM #	PART #	DESCRIPTION
40	120007	Panel Mount USB
41	512568	Buzzer
42	120011	Power Supply Board
43	120030	TSC Input/Output Board
44	600309	TSC Proofer Oven Controller Replacement Kit
45	120026	Handle, Guard Control
46	120061	Overlay, Touch Screen
47	600373	Solid State Relay, 25A
48	159092	Muffin Fan 230V
49	512880	Breaker, Circuit, 3 Amp for Proofer Light Transformer
50	512765	Thermostat, Hi-Limit
51	120001	Terminal Block
52	502937	Transformer 230V
	502840	Transformer 208V
53	156527	Power Switch

# WIRING DIAGRAM

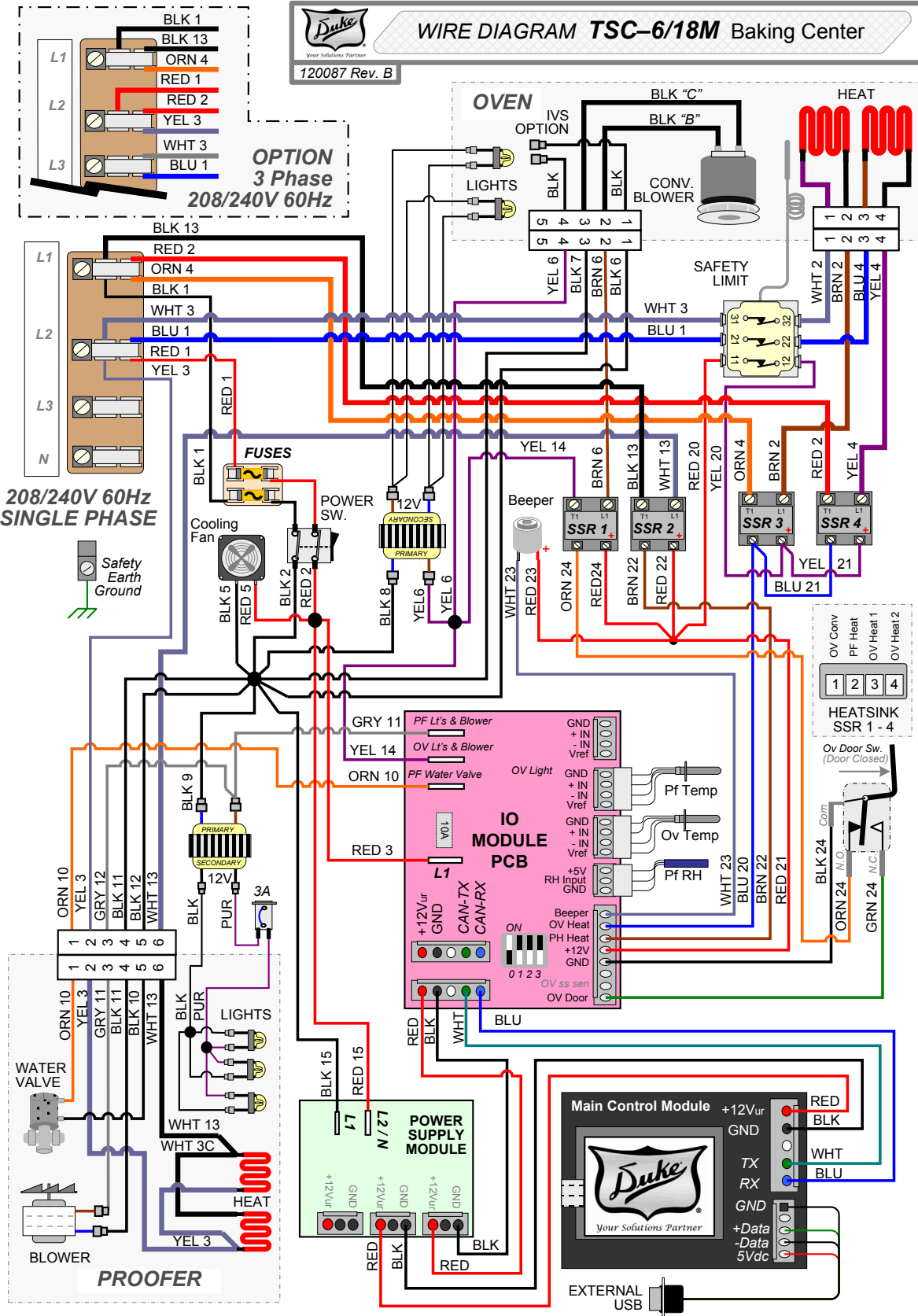

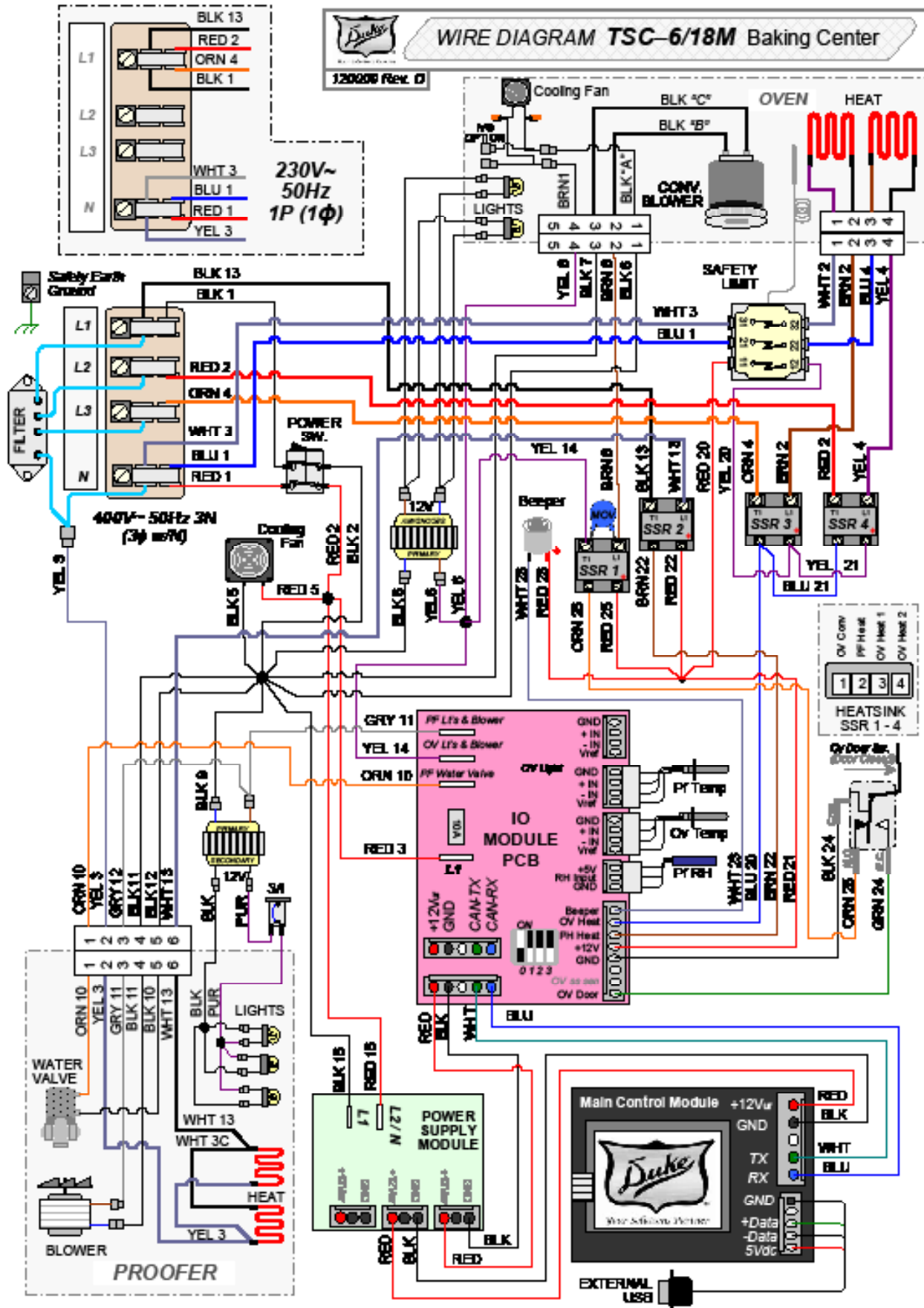





*Your Solutions Partner*

## **Duke Manufacturing Co.**

2305 N. Broadway  
St. Louis, MO 63102  
Phone: 314-231-1130  
Toll Free: 1-800-735-3853  
Fax: 314-231-5074

[www.dukemfg.com](http://www.dukemfg.com)