



Your Solutions Partner

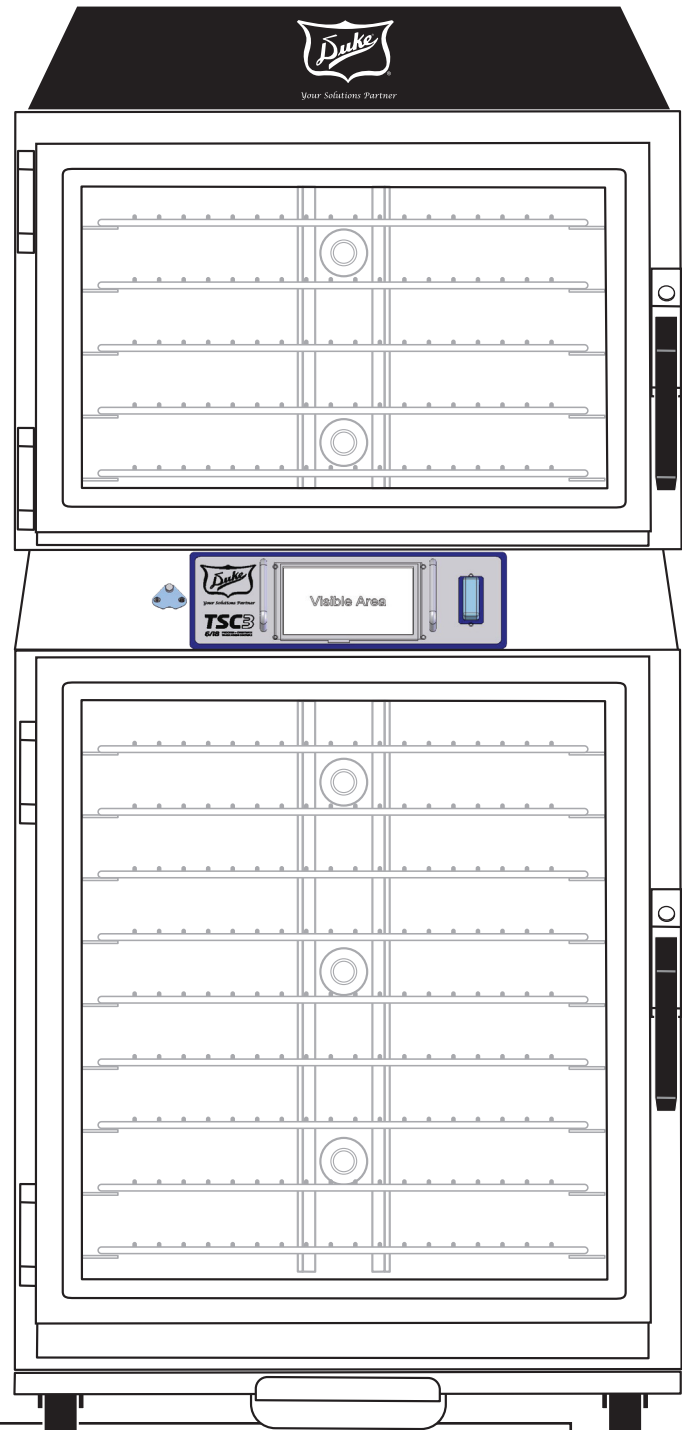
Installation and Operation Manual

Proofer Oven with Touch screen Controls (TSC)

Models:

TSC3-6/18

TSC3-3/9



CAUTION: Please read this manual completely before attempting to install, operate or service this equipment

 **WARNING:** Cancer and Reproductive Harm - www.p65warnings.ca.gov

This manual is Copyright © 2022 Duke Manufacturing Co. All rights reserved. Reproduction without written permission is prohibited. Duke is a registered trademark of the Duke Manufacturing Co.

**P/N 120085
Rev M 08/11/2022**

TABLE OF CONTENTS

INTRODUCTION	2
IMPORTANT SAFETY INSTRUCTIONS	3
SPECIFICATIONS	5
MAIN FEATURES.....	6
INSTALLATION	10
OPERATING INSTRUCTIONS.....	15
CARE AND CLEANING	20
PROGRAMMING CONTROLS.....	21
TROUBLESHOOTING	24
WIRING DIAGRAM	25

INTRODUCTION

These appliances are intended to be used for commercial applications, for example in kitchens of restaurants, canteens, hospitals and in commercial enterprises such as bakeries etc., but not for continuous mass production of food.

The Duke TSC (Touch Screen Control) Proofer Oven was developed in response to the Customer's need for uniform baking capabilities and to provide consistently high quality just-baked bread. The Duke Proofer Oven utilizes Duke's **unique directional convection airflow technology** that provides even heat distribution and a uniform bake without the need for turning pans during the bake cycle. This enhances the quality and consistency of the baked products, reduces food scrap and waste while simplifying operating process.

The low profile oven won't block the view of menu boards and will easily roll through a standard height door. The oven and proofer doors are field reversible with a drip channel on the proofer door, which prevents water from dripping on the floor.

Full-width doors on the oven and proofer help to display and merchandise fresh baked bread to the customer.

The full-width oven and proofer cavity will accept standard half-size or full-size sheet pans.

The TSC models feature a simple color LCD touch screen control that allows users to quickly select from pre-programmed recipes for baking and proofing. Advanced features are also included for custom recipes plus user accessible information for operating instructions and maintenance information.

IMPORTANT SAFETY INSTRUCTIONS

Throughout this manual, you will find the following safety words and symbols that signify important safety risks with regards to operating or maintaining the equipment.



Indicates a hazardous situation which, if not avoided, could result in death or serious injury.



Indicates a hazardous situation which, if not avoided, could result in minor or moderate injury.



Indicates Important Information



Indicates electrical shock hazard which, if not avoided, could result in death or serious injury and/or equipment damage.



Indicates hot surface which, if not avoided, could result in minor or moderate injury. Specifically, risk of burn from heating elements.



Indicates rotating fan blade hazard which, if not avoided, could result in

In addition to the warnings and cautions in this manual, use the following guidelines for safe operation of the unit.

- Read all instructions before using equipment.
- Install or locate the equipment only for its intended use as described in this manual.
- Do not use corrosive chemicals on this equipment.
- This equipment must be serviced by qualified personnel only. Contact the nearest Duke authorized service facility for adjustment or repair.
- Do not block or cover any openings on the unit.

The following warnings and cautions appear throughout this manual and should be carefully observed.

- Turn the unit off, disconnect the power source and allow unit to cool down before performing any service or maintenance on the unit.
- The unit must be grounded according to local electrical codes to prevent the possibility of electrical shock. Models supplied with a cord and plug require a grounded receptacle with dedicated electrical lines, protected by fuses or circuit breaker of the proper rating, in accordance with all applicable regulations.
- Disposal of the unit must be in accordance with local environmental codes and/or any other applicable codes.
- Properly rated all poles mains protection and earthing compliance with local electric codes are required for safe operation of this unit.
- Secure unit to a wall with the wall mounting brackets provided to prevent tipping.
- Install the Restraining Device Kit to prevent damage to mains supply connections.
- Water supply connections to the unit must comply with local plumbing code and/or standards.
- If the equipment is moved, make sure that all utility connections are properly disconnected. If the equipment is returned to its original position, make sure that any retention devices and utility connections are properly connected.
- Turn the Control Power Switch off and disconnect external all poles mains supply then allow unit to cool down before performing any service, maintenance or cleaning on the unit.
- When working on this equipment, observe precautions in this manual or labels attached to or shipped with this equipment and other safety precautions that may apply.
- Be careful of a possible slippery floor adjacent to this equipment.
- Always use sufficient number of trained and qualified personnel to move the appliance. Do not tilt. Appliance can tip over when being moved over an uneven floor or threshold and cause serious injury. Always apply caster brakes when not being moved.
- This appliance is not intended for use by persons (including children) with reduced physical, sensory, or mental capabilities, or lack of experience and knowledge, unless they have been given supervision or instruction concerning use of the appliance by a person responsible for their safety.







SPECIFICATIONS

Patent Pending -
Model TSCM, TSC3

Unit Weight:	580 lbs / 263 kg
Shipping Weight: Carton Box	630 lbs / 286 kg
Shipping Weight: Wooden Crate	720 lbs / 327 kg

Line Ratings - TSCM & TSC3 Proofer Oven with Touch Screen Control				
Line Supply Voltage (V)	Line Supply Frequency (Hz)	Line Phase Configuration	Total Maximum Line Power Watts (W)	Total Maximum Line Current Amps (A)
208	60	Single Phase	6 650	32
208	60	3 ~	6 650	32 ▲ 1
240	50 & 60	Single Phase	7 200	30
240	60	3 ~	7 200	30 ▲ 1
380	50 & 60	3N ~	6 100	30 ▲ 2
400	50	3N ~	6 600	30 ▲ 2
415	50 & 60	3N ~	7 200	30 ▲ 2
▲ 1 L1<15A, L2<15A, L3<25A		▲ 2: L1<15A, L2<15A, L3<15A, N = Comm		

Compliance Declaration - TSC3, TSC-M Proofer Oven with Touch Screen Control

	LISTED COMMERCIAL COOKING APPLIANCE	Standard: UL197	File: KNGT.E17421
		FCC Part 15 Subpart B:2017	
	INDEXER COMMERCIAL APPAREIL DE QUISINE	Standard: CSA-C22.2 No. 109 ICES-003:2017	File: KNGT7.E17421
		Standard: ANSI / NSF 4	File: TSQT.E157479
 IPX4		Directive 2006/95/EC: IEC 60335 1:2010, +A1:2012, A1:2013 IEC 60335 2 42:2002, + A1:2008 IEC 60529 ED.2.2 B:2013 EN60335 -1:2012 + 11:2014 EN 60335-2-42:2003 + A11:2008, + A11:2012	Directive 89/336/EEC: EN62233:2008 EN61000-6-3:2007 EN55014-2:2015 EN61000-6-2:2016 EN61000-6-4:2011
		WEEE Directive 2002/96/EC RoHS 2011/65/EU	Directive 2014/53/EU: EN 301 489-1:2016 EN 301 489-17:2009

MAIN FEATURES

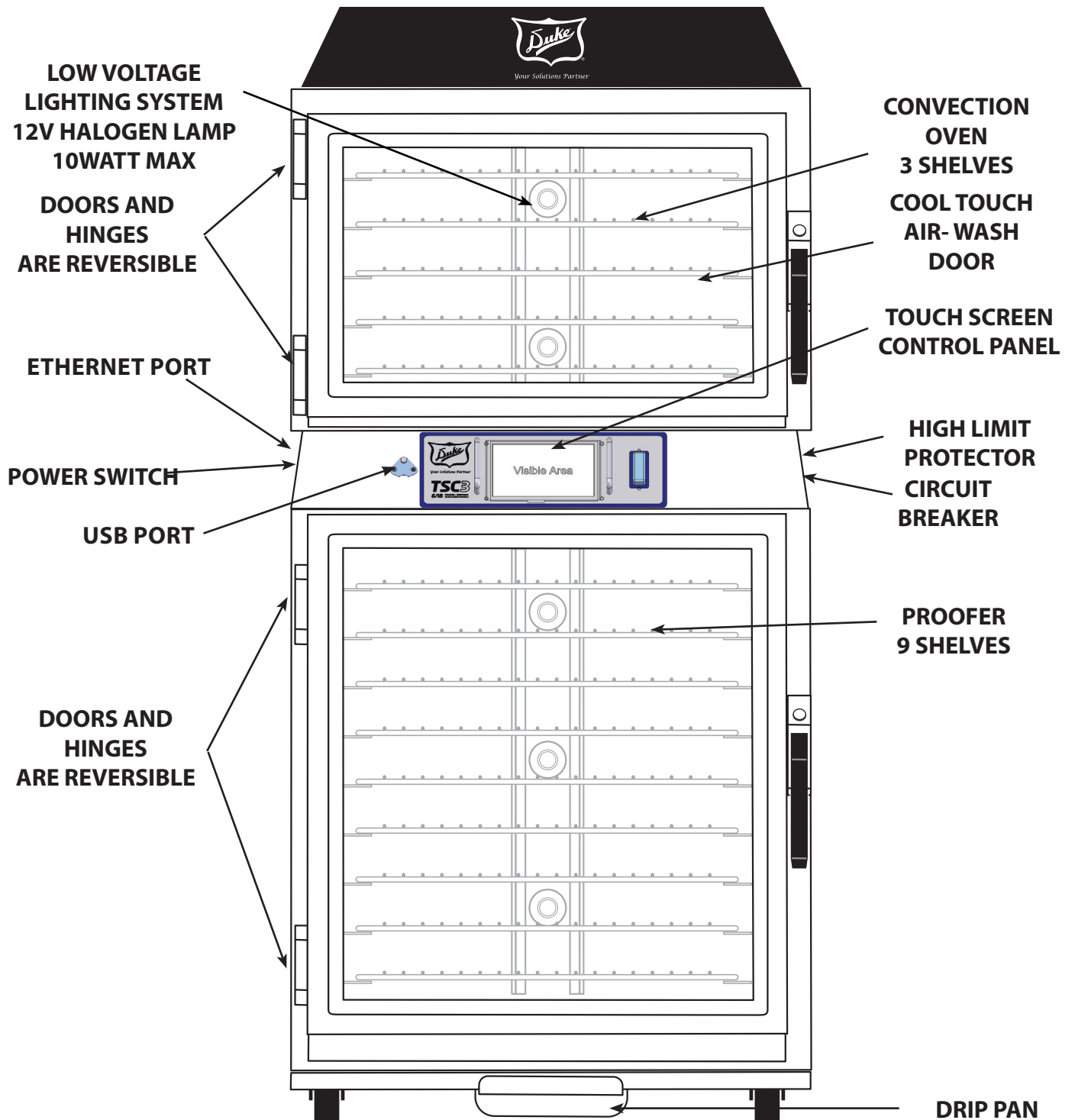
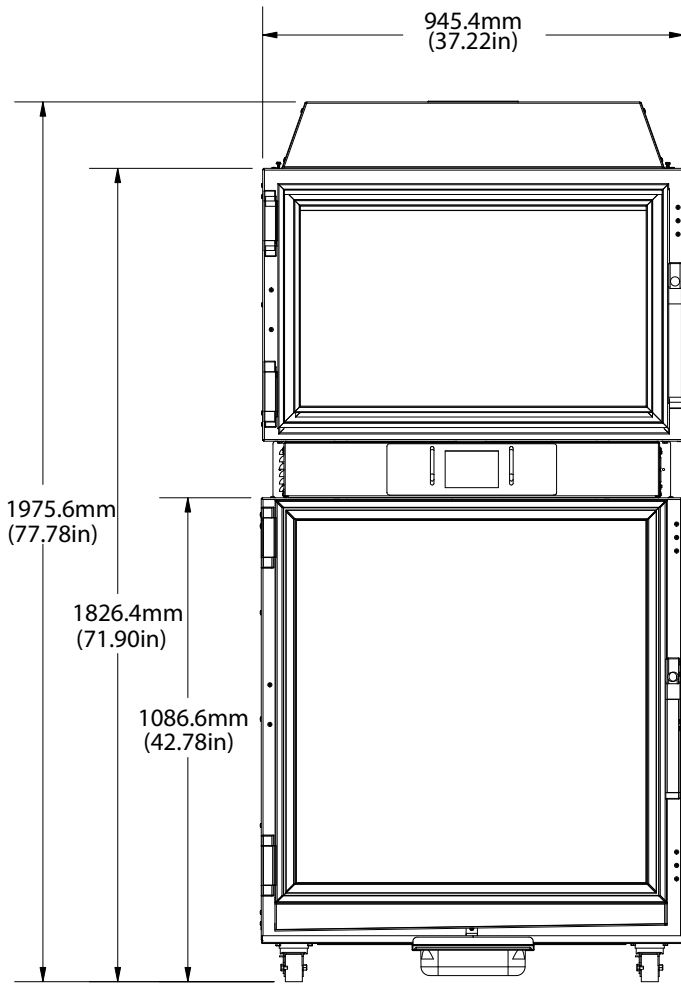
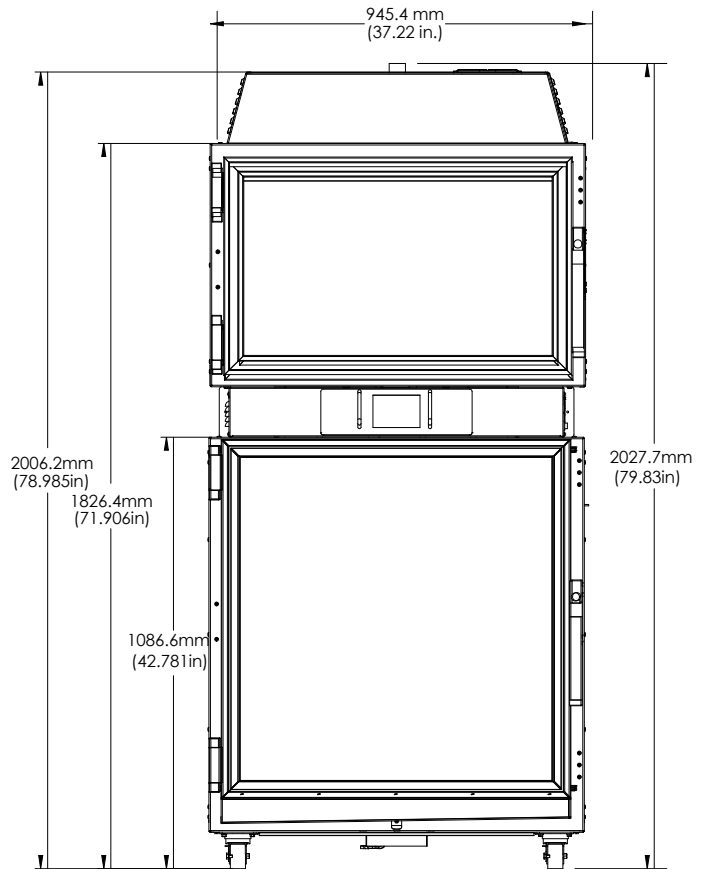


Figure: Main Features

DOMESTIC FRONT VIEW - DIMENSIONS

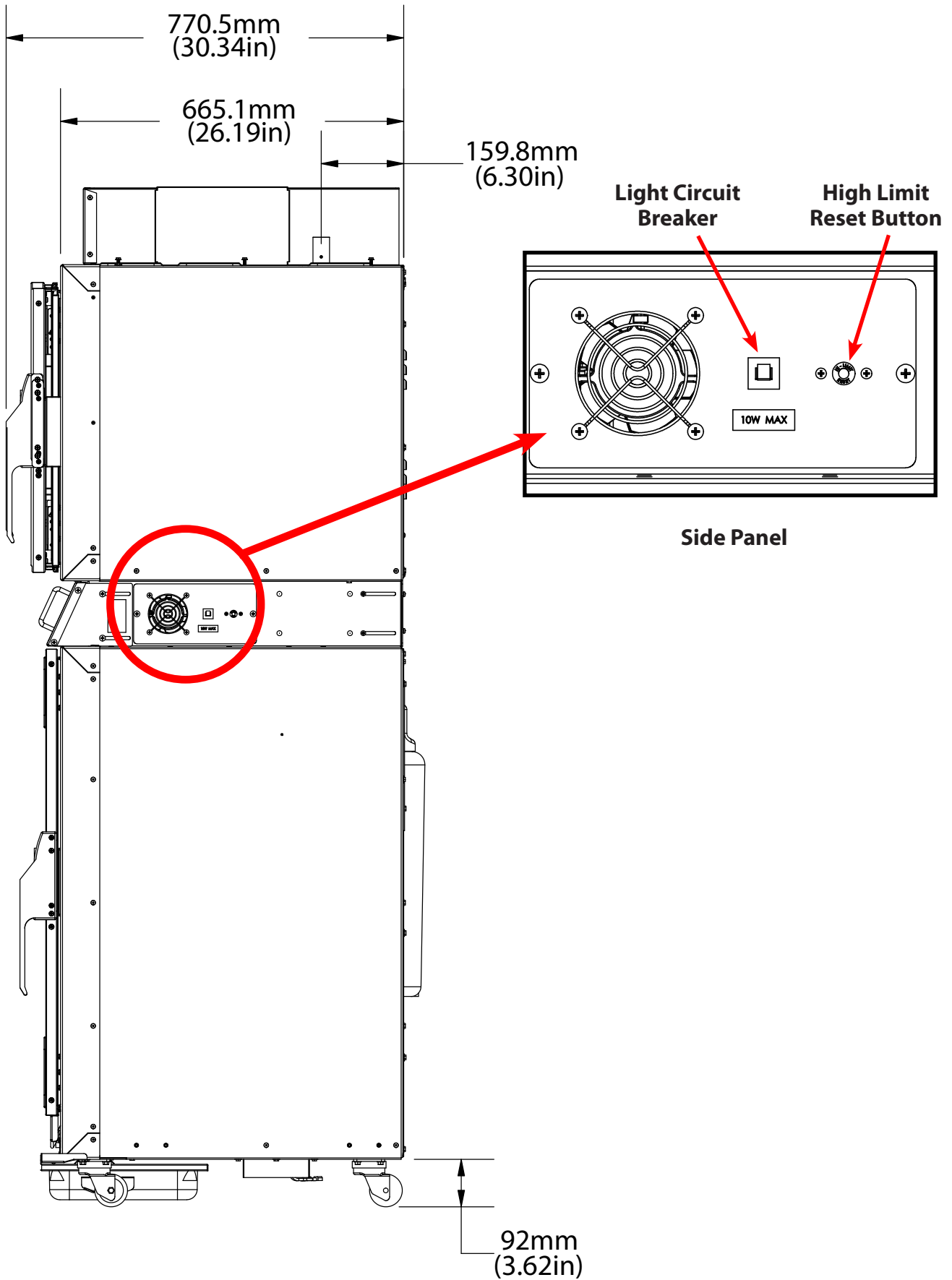


INTERNATIONAL (CE) FRONT VIEW - DIMENSIONS

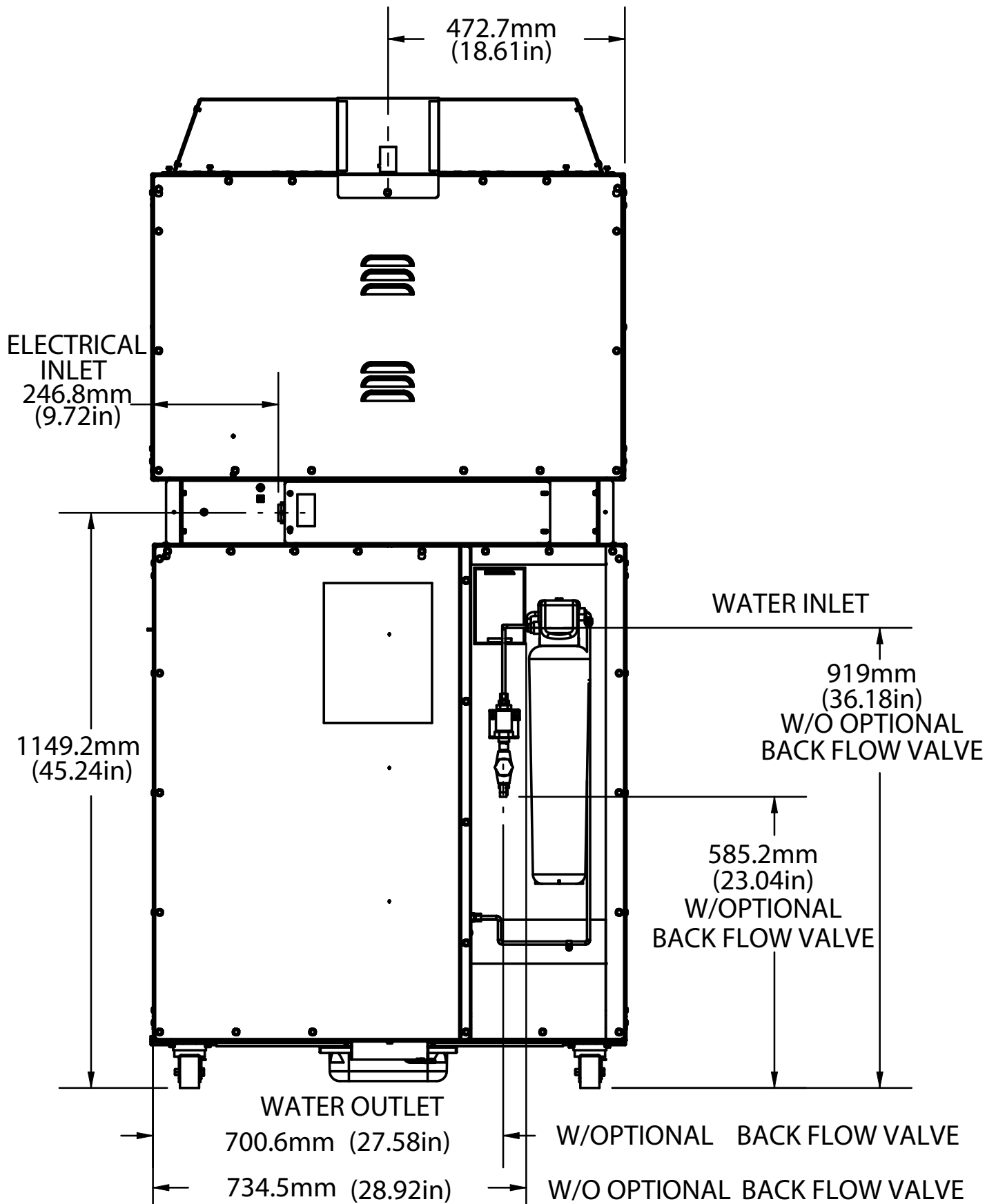


Model	Overall Depth		Overall Height		Overall Width	
	in	mm	in	mm	in	mm
Domestic	30.34	770.6	77.78	1975.6	37.22	945.3
International	30.34	77.06	79.83	2027.7	37.22	94.53

SIDE VIEW - DIMENSIONS



BACK VIEW - DIMENSIONS



INSTALLATION

UNPACKING UNIT

Inspect the shipping carton and/or container, carefully noting any exterior damage on the delivery receipt; also note any damage not evident on the outside of the shipping container (concealed damage). Contact the carrier immediately and file a damage claim with them. Save all packing materials when filing a claim. Freight damage claims are the responsibility of the purchaser and are not covered by the warranty.

- Follow the instructions on the Carton Box for unpacking the unit.
- Inspect unit for damage such as, broken glass, etc.
- Report any dents or breakage to source of purchase immediately.
- **Do not attempt to use unit if damaged.**
- Remove all materials from unit interior.
- If unit has been stored in extremely cold area, wait a few hours before connecting power.

UNIT PLACEMENT

- Do not install unit next to source of heat, such as deep fryer, etc.
- Install unit on level surface floor.
- Minimum Clearance of 6" (152mm) must be maintained between the unit and any combustible substance.
- Either side of the unit must remain open for proper airflow for electrical component cooling. The rear of the unit and one side may be installed without clearance.



ELECTRICAL SHOCK HAZARD UNIT MUST BE SAFETY GROUNDED, EARTHED.

DO NOT MODIFY OR DEFEAT ELECTRICAL CONNECTIONS

ELECTRICAL AND SUPPLY CONNECTIONS

Connection of the unit to the mains supply **MUST** be performed by an authorized person in accordance with codes, standards, and laws governing the installation site using properly rated all poles mains protection, full disconnection under over voltage category III, safety ground earthing, and shall be a minimum of 48" (1.2 meter) long to allow the equipment to be moved for cleaning.

USA and non-EU Countries must use flexible conduit within variances that may be required by local electric codes or regulations.

All International installations must use IEC 60245 IEC 66, HO7RN-F, minimum 5G 2,5mm, 5G4.0mm maximum flexible cordage.

For 1~ appliances use minimum 3G 4.0mm, 3G 6.0mm maximum flexible cordage.

The Mains Supply safety / earth ground wire must be longer than mains conductors at the unit's interconnections to prevent stress under pull.

Contact Duke for service of IVS (Integrated Ventilation System) HO5RN supply interconnection.

EXTERNAL EQUIPOTENTIAL



Terminal provides a connection for bonding to equipment enclosure.

WATER SUPPLY CONNECTION

This equipment must be installed in accordance with all applicable federal, state, and/or local plumbing codes having jurisdiction.

The water inlet utilizes 1/4" (6.35mm), OD plastic tubing. Install the tubing in a manner to ensure there are no kinks, strains, or tight bends. Leave sufficient length to allow unit movement for service and cleaning.

The tubing should be cut square and be free of any deformations at the connection points. All burrs and sharp edges should be removed for proper connection.

Insert the tubing through the compression fitting with the threads pointing towards the end of the tubing.

Push the tubing into the fitting as far as it will go and tighten the nut with a 1/2" (12.7mm), wrench. Do not over-tighten the nut. If leaks occur, further tighten the fitting until the leakage stops.

INSTALLATION - continued

INSTALLATION

1. This unit can be converted to other mains supply configurations by Duke Manufacturing approved service personnel. Call Duke Service Department for action if electrical rating tag information is not compatible with the available mains supply.
2. This unit is supplied with the national and international specified water supply interconnection. Back flow prevention protection is optionally supplied as a factory installed option or as an add-on kit. Local regulation variances or additional requirements must be evaluated prior to installation. New water supply line interconnection must be used when installing this unit. Maximum / minimum supply pressure specification is 65PSI (448kPa) / 40PSI (275kPa) for all system plumbing components. See **INSTALLATION OF WATER FILTER** section prior to water supply interconnect.
3. This appliance must be secured to building structure. A restraining device kit (#153586) provided with the unit limits the movement of the appliance without transmitting stress to the mains supply. Installation instructions are in the kit.
4. **IMPORTANT:** A minimum clearance of 6"(152mm) from the top of unit to the ceiling must be provided. Unit may be installed with minimal clearance on one side and rear of the cabinet.
5. Check the swing of the door. The hinge side can be changed by referring to the **Reversing Oven Door Swing Direction section of this manual.**
6. Check the door seal and make sure both doors close completely. If they do not close and seal properly, refer to the **Door Gasket Adjustment section of this manual.**



HAZARDOUS VOLTAGE RISK OF ELECTRIC SHOCK

DISCONNECT POWER TO SERVICE COMPARTMENT

THIS RESTRAINING DEVICE MUST ALWAYS BE CONNECTED WHEN THE APPLIANCE IS IN SERVICE. DISCONNECT ONLY FOR SERVICING AND/OR CLEANING, THEN RECONNECT WHEN THE APPLIANCE HAS BEEN RETURNED TO ITS NORMAL POSITION.

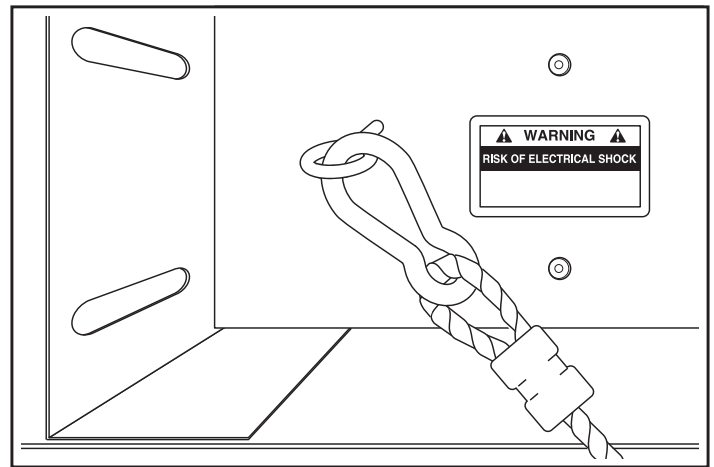


Figure: Restraining Device Kit (Part # 153586)

7. Place the wire racks in the oven and proofer.
8. Unit can be mechanically attached to wall using optional wall-mounting brackets. Optional wall-mounting brackets are not required for safe operation of the unit. Refer to **Installation of Wall Brackets section of this manual** for the instructions on Installation of Wall Brackets to the wall.

INSTALLATION - continued

TECHNICAL DESCRIPTION AND APPLICATION NOTES FOR TSC PROOFER OVEN BACK FLOW PREVENTER SYSTEM

Check with your local authority having jurisdiction regarding approvals for connecting the Duke TSC Proofer Oven to a potable water supply before making any plumbing connections. Plumbing code requirements vary, but European Union (CE) and other jurisdictions require a back flow prevention device that is factory-installed or available as a kit (P/N 600187). The back flow prevention device used on Duke TSC Proofer Ovens protects water supply systems by preventing the reverse flow of non-potable water into the potable domestic water system. The device consists of two independently acting check valves, internally force-loaded to a normally closed position and designed/constructed to operate under intermittent or continuous pressure conditions. The two main components of the Duke back flow preventer system are:

- Dual Check Valve type back flow preventer that conforms to ANSI/ASSE standard #1024 and is CSA standard B64.6 certified.
- Inlet water strainer equipped with 100-mesh screen and installed up stream of the back flow preventer. The screen is conveniently located on the rear panel of the proofer, below the back flow preventer, for easy access during cleaning/replacement.

Duke Manufacturing Co.

This equipment is intended to be connected to a potable water supply system under pressure and is to be installed with adequate backflow protection to comply with all applicable federal, state, and local codes.

Water supply pressure for proper operation shall be:
Minimum 40 PSIG(275 kPa)
Maximum 65 PSIG(448 kPa)
measured at water line inlet to the equipment.

If so equipped, regular maintenance is required to replace the water filter cartridge at least once per year, and to clean the inlet water screen at least once per year. Consult state/local codes for any additional requirements.

INSTALLATION OF WATER FILTER

Install new filter by removing sanitary cap from top of cartridge, ensure two black O-rings are in place, then lift up into filter head and rotate cartridge 1/4 turn counter clockwise until it comes to a complete stop. Flush 2 gallons (7.6 Liters) of water through the new filter before using proofer to purge air from filter. Remove hose from bottom of proofer by loosening the compression nut at the disconnect fitting and pull hose out. Place hose over container and turn on water. It will take a minute for the filter to fill before water flows out of hose into container. once filter is flushed with 2 gallons (7.6 Liters) of water, turn off water supply again, insert hose into water line disconnect, tighten compression nut and turn water supply on again. Check for leaks at connection fittings.

Patent(s) Pending

INSTALLATION - continued

INSTALLATION OF WATER FILTER

1. Install new filter by removing sanitary cap from top of cartridge, insure two black O rings are in place, then lift up into filter head and rotate cartridge 1/4 turn counter clockwise until it comes to a complete stop.
2. Flush 2 gallons (7.5 Liters), of water through the new filter before using proofer to purge air from filter. Remove hose from bottom of proofer by loosening the compression nut at the disconnect fitting and pull hose out. Place hose over container and turn on water. It will take a minute for the filter to fill before water flows out of hose into container.
3. Once filter is flushed with 2 (7.5 Liters), gallons of water, turn off water supply again, insert hose into water line disconnect, tighten compression nut and turn water supply on again. Check for leaks at connection fittings.

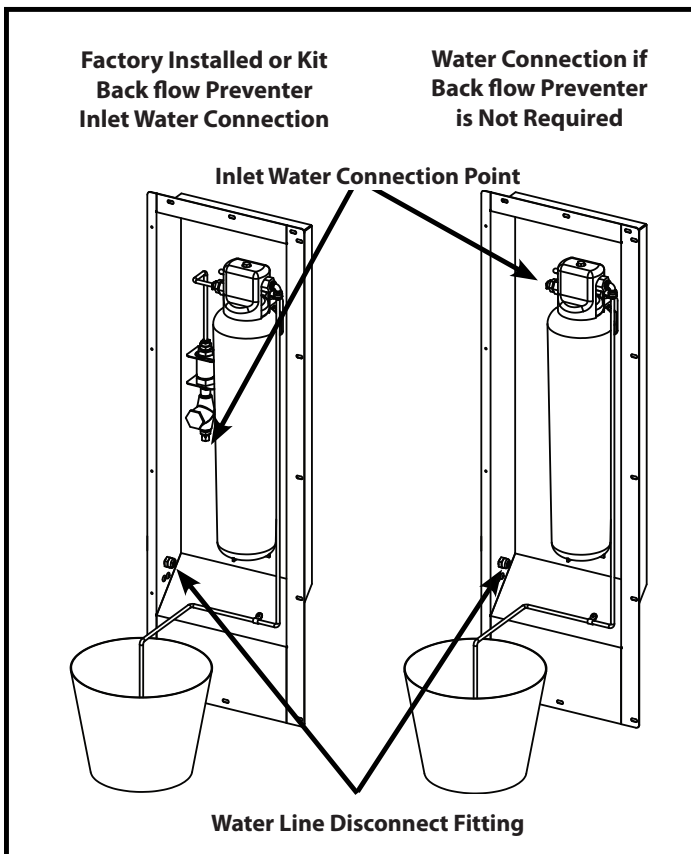


Figure: Water Filter
(Flushing 2 gallons (7.5 Liters), of water)

INSTALLATION OF WALL-BRACKETS

NOTE: Verify interconnections and function prior to installing optional wall brackets

1. Mount the Wall Mounting Brackets with screws provided with the Proofer Oven.
2. Extend the Wall Mounting Bracket towards the wall by sliding it through the slot provided but do not tighten the screws.
3. Mark the Wall and Drill holes for the wall anchors.
4. Insert the wall anchors into the holes.
5. Position the Wall Mounting Brackets against the wall.
6. Insert the screws into the Wall Mounting Bracket.
7. Ensure that the Brackets are firmly against the wall and tighten the screws securely.

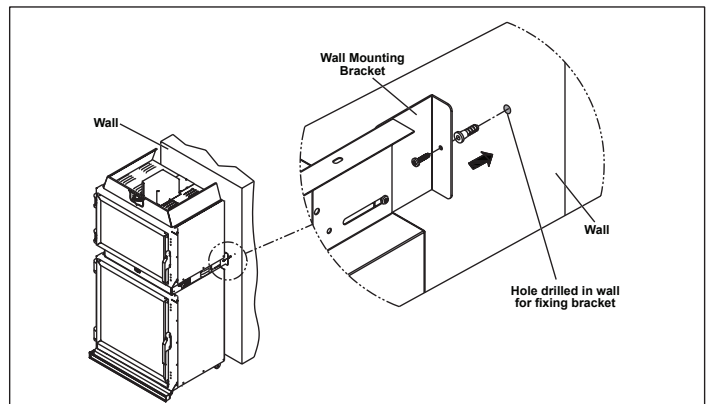


Figure: Wall Mounting Bracket

OPERATING INSTRUCTIONS

PROOFER OVEN START-UP



ELECTRICAL SHOCK HAZARD.

TASKS MUST BE PERFORMED BY A QUALIFIED SERVICE TECHNICIAN OR ELECTRICIAN.

1. Have a qualified service technician or electrician connect the Proofer Oven to the power supply.
2. Turn power on to the unit with the power switch on the left side of the unit. Boot Screen is displayed and automatically transitions to the Main Screen.
3. Turn the oven and proofer ON by touching the



and buttons located at the left of the touch screen. The Oven, Proofer and Recipe Buttons will turn to BLUE background. The Oven and Proofer lights will turn on and start preheating.

4. Verify Humidification of the proofer. Humidification will begin automatically. Humidity level will be controlled according to user-selected %RH set point.
5. Check the door seals and make sure both doors close completely.
6. If the unit does not power up correctly or if the doors do not close and seal properly, call Duke for assistance.



Figure: Main Screen

Installation and Operation of: *DUKE TSC3 Proofer Oven with Touch Screen Controls*
OPERATING INSTRUCTIONS

Touch Screen Definitions

The diagram illustrates the touch screen interface. At the top is the **Main Tool Bar** containing a **Screen Sleep Button*** and an **Info Button**. Below this are two main recipe screens: the **Oven Recipe Information Bar** and the **Proofer Recipe Information Bar**. The Oven screen shows recipe names like BREAD, COOKIES, and BREAD 2, along with temperature (370 F) and time (12:00). The Proofer screen shows recipe names like 60 MINUTES, DRY OUT, and PROOF 3, along with humidity (80%), temperature (105 F), and time (60:00). Navigation buttons for **Page Back** and **Page Forward** are shown. A **Door Open** screen displays 'DOOR OPEN' and 'READY' with a progress bar. A **Dry Out** screen shows 'DRY OUT', 'OFF', temperature (125 F), time (60:00), and instructions: 'Wipe down exposed surface to remove excess water', 'LEAVE DOOR OPEN APPROXIMATELY 2 INCHES', and 'Proofer turns off when Dry Out is complete'. A note states: 'Touch to start Dry-Out cycle at end of use for each day.'

* Screen Sleep Button only available when Oven and Proofer are off

AUDIBLE ALARMS

The Oven/Proofer has various audible alarms.

1 chirp	Keystroke acknowledgement
3 short chirps	Oven and Proofer up-to-temperature notification
4 beeps (Continuous until cleared)	Oven door open alarm
3 long chirps	Proofer stagger load alarm
3 beeps (Continuous until cleared)	Proofer end of cycle
2 beeps (Continuous until cleared)	Oven end of cycle
1 beep/2 beep pattern (Continuous until cleared)	Seasoning Alarm

OPERATING INSTRUCTIONS - continued

DAILY OVEN/PROOFER START-UP



1. Turn power on to the unit with the power switch on the left side of the unit. Boot Screen is displayed and automatically transitions to the Main Screen.
2. Turn the Oven and Proofer ON by touching the  and  buttons located at the left of the touch screen. The Oven, Proofer and Recipe Buttons will turn to BLUE background. The Oven and Proofer lights will turn on and start preheating.



Figure: Main Screen

3. Check to make sure that the oven and proofer fans are running.
4. Open the oven door; the oven fan should stop.
5. Close the door; the fan should resume.
6. Allow the oven and proofer to pre-heat for at least 30 minutes. An audible alarm will sound (3 short chirps) when the oven and/or proofer reach the ready state. Your Duke Proofer Oven is now ready to operate.

If there are any problems refer to the Trouble Shooting section of this manual.

PROOFER OPERATING INSTRUCTIONS


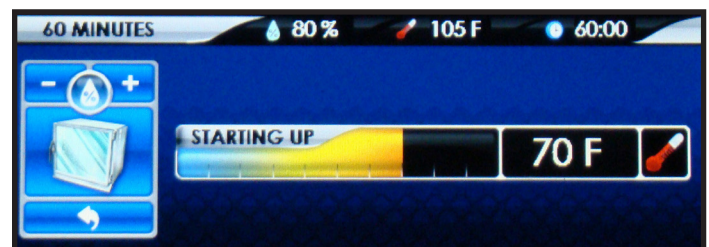
1. Turn the proofer ON by touching the  button or the desired RECIPE button. The Proofer and Recipe Buttons will turn to BLUE background. The Proofer lights will turn on and proofer will start preheating.

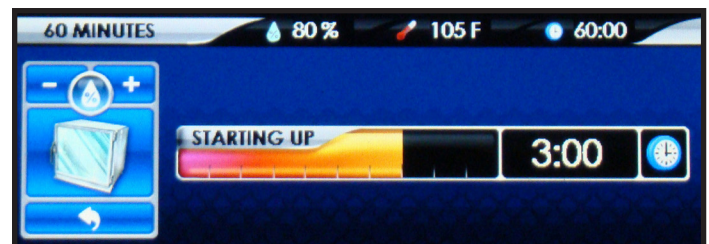


Figure: Proofer Main Screen

2. Proofer will preheat for 10 minutes after reaching set point to ensure proper proofing conditions. An audible alarm will sound (3 short chirps) when the proofer reaches the ready state.



**Figure: Proofer Starting Up Screen
(If under temperature set point)**



**Figure: Proofer Starting Up Screen
(10 Minute Starting Up Timer)**

OPERATING INSTRUCTIONS - continued






- Once a Proofer recipe has been selected (i.e. **60 MINUTES** ) and the display has changed to the Proofer Recipe Ready to start 1/3rd Timers screen, the proofer's humidity should be visually verified before loading.





Figure: Proofer Recipe Ready Screen to Start

- Watch for a light fog to appear on the interior door glass; the proofer is ready to be loaded with dough.
- Increase humidity, if door glass does not fog as the humidity is set too low; press  button of the  (Relative Humidity). The RH% will increase on the Proofer Recipe Information Bar.
- Decrease humidity if water is running down door glass as the humidity is set too high; press  button of the  (Relative Humidity). The RH% will decrease on the Proofer Recipe Information Bar.

Is RH% right?



75%RH to 85%RH is usually between fogged glass & droplets running in most ambient environments

- Load the first proofer section with dough and touch UPPER, MIDDLE or LOWER Start Timer , depending on where dough is loaded. This will prevent over-proofing of the dough remaining in proofer after the first load has been moved to the oven. The remaining time will be displayed in the button area and the progress bar will change to visually show elapsed and remaining proof time. Since the proofer can hold more pans than the oven can bake, an alarm beeps and LOAD NEXT TRAY is displayed in the Main Tool Bar 1/3rd of the time thru the proofer cycle so that loads can be staggered. Load the next proofer section with dough and touch Start Timer  for the respective section.

NOTE: You can cancel an active timer with touch and hold for 2 to 3 seconds on the count down timer.



Indicates time to add seasoning.

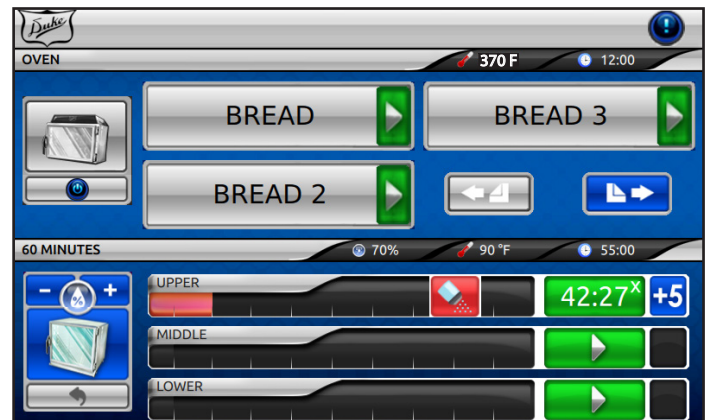


Figure: Proofer Running Screen

- When the proof is complete, an alarm for the respective timer will beep to alert the operator which level is ready to be moved to the oven. Touch the Timer **0:00^x** to cancel the alarm.

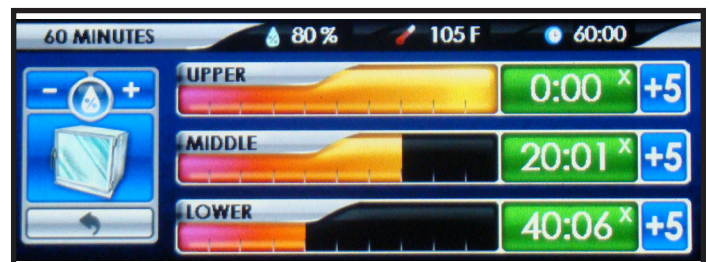


Figure: Proofer Complete Alarm Screen

OPERATING INSTRUCTIONS - continued

- You can add 5 minutes to proofing time by touching the **+5** button adjacent to any of the respective count down timers. This can be done at any time during the proof or at the end of a proofing cycle. You must add time in 5 minute increments.
- Adjust the time, if necessary, depending on type of dough and desired results.
- Bake bread when dough rises to desired size.

NOTE: Excessive humidity on the door glass is probably caused by a humidity setting that is too high or by having the humidity on when there is no dough loaded in the proofer.

OVEN OPERATING INSTRUCTIONS


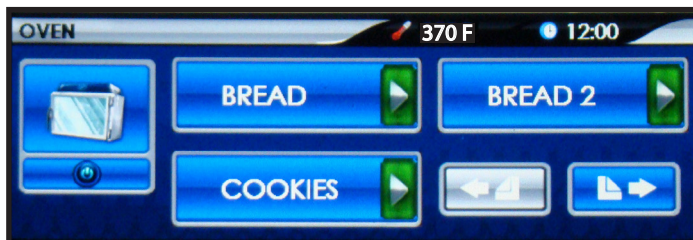

- Turn the oven ON by touching the  button or the desired RECIPE button. The oven lights will turn on and the Oven will start preheating. An audible alarm will sound (3 short chirps) when the oven reaches the ready state.



Figure: Oven Main Screen



- Allow the oven to preheat 20–30 minutes and keep the oven door closed, except during loading and unloading.
- Once an Oven recipe has been selected (i.e. ) , the display will change to the Oven Recipe Ready to Start screen (if preheating is complete).

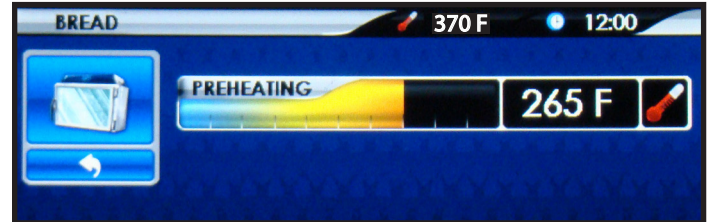



Figure: Oven Recipe Preheat Screen (if under temperature set point):



Figure: Oven Recipe Ready to Start

- Load the oven with dough and touch the start timer  button. The remaining time will be displayed in the button area and the progress bar will change to visually show elapsed and remaining bake time.

NOTE: You can cancel an active timer with press and hold for 2 to 3 seconds on the count down timer.

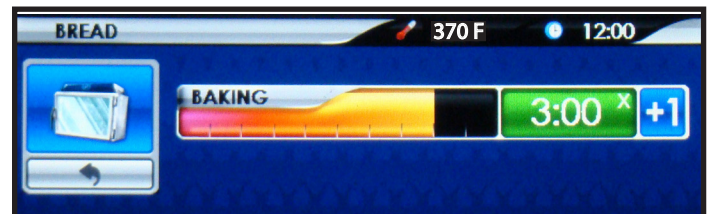


Figure: Oven Count Down Timer

OPERATING INSTRUCTIONS - continued

- When the bake is complete, an alarm will beep to alert the operator. Touch the Timer **0:00** ^x or open the oven door to cancel the alarm.

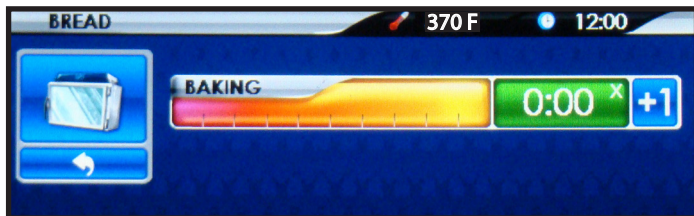


Figure: Oven Bake Complete Alarm

- You can add 1 minute to baking time by touching the **+1** button adjacent to the count down timer. This can be done at any time during the bake or at the end of a baking cycle. You must add time in 1 minute increments.
- Adjust the time, if necessary, depending on type of dough and desired results.

BAKING TIPS

- Always select the oven recipe and allow preheat time prior to loading product. Only load when the Oven Recipe Ready to Start Timers screen is displayed. Load the oven with six pans of dough and touch the start button.
- If the bread color is uneven, reduce temperature and extend bake time in recipe (see Programming Controls).
- If the bread is too dark, reduce the bake time in the recipe (see Programming Controls). If the bake time is reduced and the bread is still too dark, reduce the temperature by 15° F (10° C) and bake longer.
- When baking partial loads, center the pans in the oven and start loading at the bottom shelf and work up to the top.
- Opening oven door allows heat to escape. Under normal conditions, quick loading and unloading will not be a problem. If door is left open too long, oven performance will be affected.

NOTE: The Proofer Oven has a "Default" run mode. This mode is only active when there is a Touchscreen control communication error and with power to the balance of the controls. This mode allows for your Proofer Oven to maintain approximately 370° F (188° C) in the baking oven and approximately 105° F (41° C) and 80%RH in the proofer. When the Proofer Oven is operating in this mode, you will witness the Proofer and Oven lights blinking off for approximately 2 seconds every minute. This mode allows you to continue using your Proofer Oven for baking and proofing until the unit is properly serviced.

The "Default" run mode is disabled with an open oven door.

CARE AND CLEANING

⚠️ WARNING ⚡ PROOFER OVEN INTERIOR AND RACKS ARE VERY HOT AND COOL SLOWLY. ALLOW TO COOL BEFORE HANDLING.

⚠️ CAUTION ⚡ ELECTRICAL SHOCK HAZARD:
DO NOT WASH WITH WATER JET OR HOSE.

CAUTION DO NOT USE OVEN CLEANERS, CAUSTIC CLEANERS, DE GREASERS, ACIDS, AMMONIA PRODUCTS, ABRASIVE CLEANERS, STEEL WOOL, OR ABRASIVE PADS CONTAINING IRON. THESE CAN DAMAGE THE STAINLESS STEEL, DOOR GASKETS AND PLASTIC SURFACES.

DAILY CLEANING INSTRUCTIONS

1. Empty and clean Drip Pan with clean damp cloth.
2. Clean stainless steel exterior with stainless steel cleaner or polish, or with hot soapy water followed by a clean water rinse.
3. Clean oven and proofer doors with a glass cleaner.
4. Clean oven and proofer interiors with a damp cloth. If heavy soil areas exist clean with hot soapy water and follow with clean damp cloth.
5. Run Dry Out cycle. Touch **DRY OUT** on the main screen.

- Follow instructions given on screen after touching **DRY OUT**. This special function allows automatic water dry out after daily proofer use is completed.



Figure: Proofer DRY OUT Screen

- Proofer will turn off when DRY OUT is complete.

NOTE: DRY OUT is a 60 Minute cycle with extra heat and without water to dry out the Proofer for cleaning.



Figure: Proofer Main Screen

PROGRAMMING CONTROLS


To access the SPECIAL FUNCTIONS, touch  button on the Main Tool Bar.



Figure: Main Tool Bar

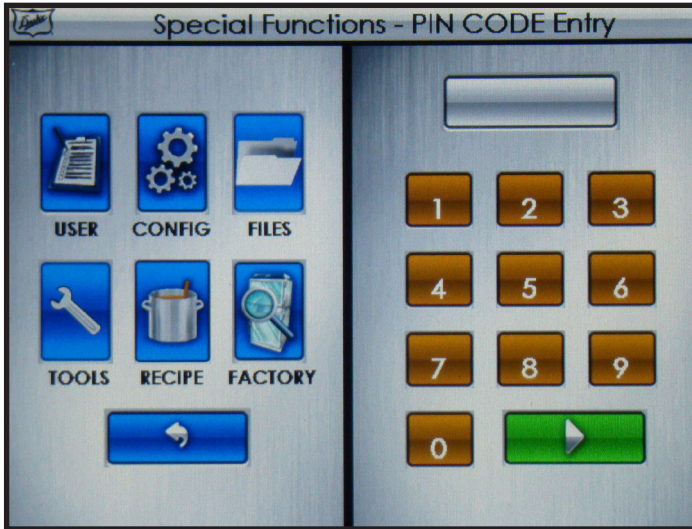





Figure: Special Functions Screen




I. RECIPE EDIT PROGRAMMING INSTRUCTIONS

1. Touch the  button and then enter pin code 5 6 7 8 and Touch the  button when prompted.
2. Touch the button for the recipe you want to edit (i.e. ).

NOTE: The 6 oven recipes are listed in the top 3 rows and the 6 proofer recipes are listed in the bottom 3 rows.




FIGURE: Recipe Edit Selection Screen

3. To edit Time, Temperature, Humidity or seasoning (proofer only) touch the  or  button adjacent to the field you want to change. Touch the  button to save the changes.

NOTE: You must touch the  button in each field to save the changes you made.












Figure: Recipe Edit Screen

4. To edit the recipe name, touch the  button for the EDIT RECIPE NAME screen.

NOTE: Typing will add letters/characters to the end of the text.

PRESS:


-  TO TOGGLE THE KEYBOARD BETWEEN THE UPPER/LOWER CASE CHARACTER SET.
- ,  AND  FOR THE NUMBER AND SYMBOL KEYBOARDS.
-  TO SPACE
-  TO CLEAR ALL TEXT
-  TO DELETE/BACKSPACE


5. Touch the  button to save the changes and return to the RECIPE EDIT Screen. If no changes are required touch the  button to go back to the RECIPE EDIT Screen.

PROGRAMMING CONTROLS - continued



Figure: Edit Recipe Name Screen

NOTE: You must touch the  button to save the changes you made.

When complete, touch the  button to go back to the previous screen. Press multiple times to return to the main screen.

CONFIG (CONFIGURATIONS)

1. Touch the button for the setting you want to edit.




- **DATE/TIME** – Reserved for future use.



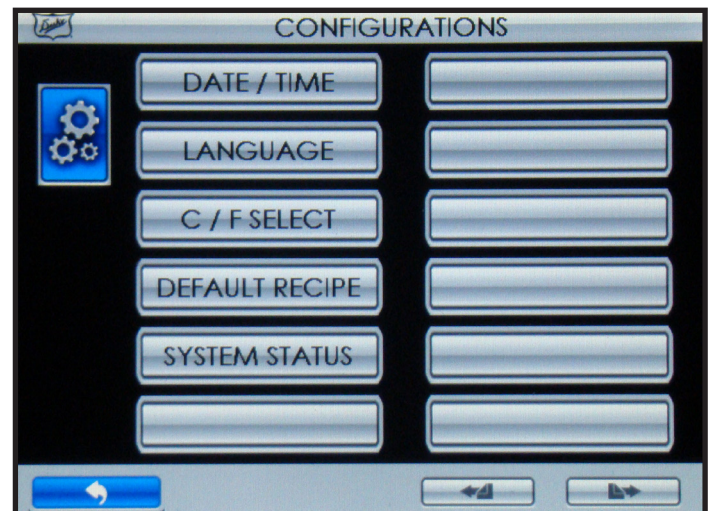
- **LANGUAGE** – Touching will display a list of included languages.
 - a. Touch the preferred language button that best meets your needs and press the button to save.

Note: Not all languages are available.

- b. Select Default Recipes on the configuration screen to complete language change and press the  button twice to exit programming.



- **C/F SELECT** – Touching will toggle between CENTIGRADE MODE ENABLED and FAHRENHEIT MODE ENABLED.

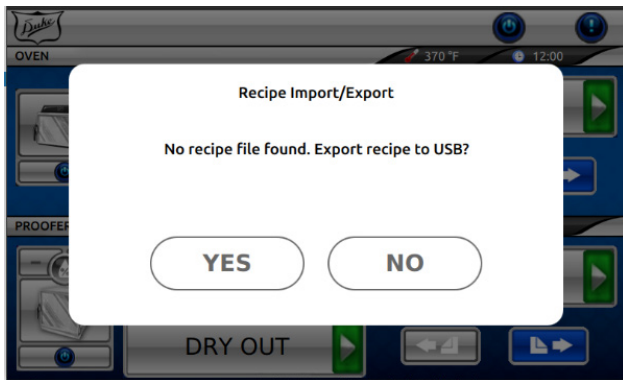


- **DEFAULT RECIPE** – Touching will reload factory defaults.
- **SYSTEM STATUS** – Touching will display Proofer Oven status.

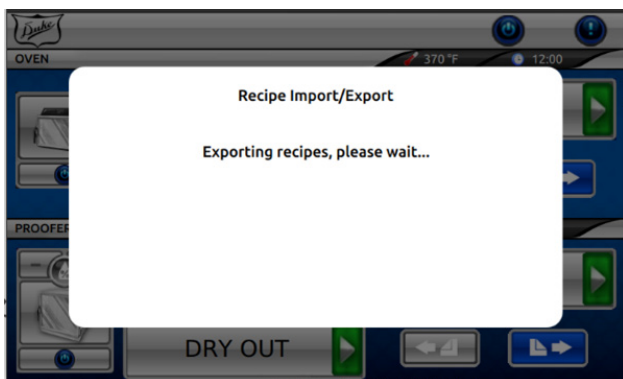
PROGRAMMING CONTROLS - continued

Recipe Export

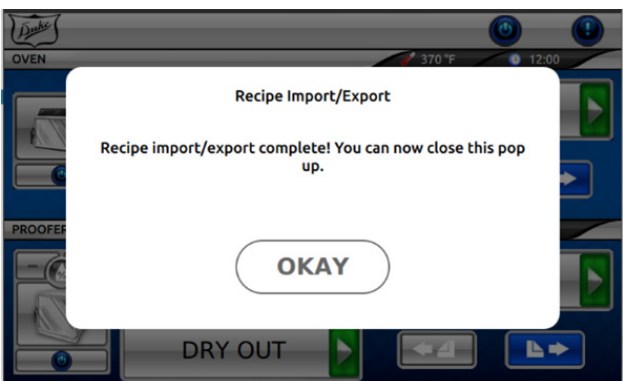
1. With the unit powered on, insert a **BLANK** USB drive into the USB port on the front of the unit.



2. Press the "YES" button to start the recipe export to the USB drive. The pop-up message will dismiss, and recipe export will not happen if you press the "NO" button instead.



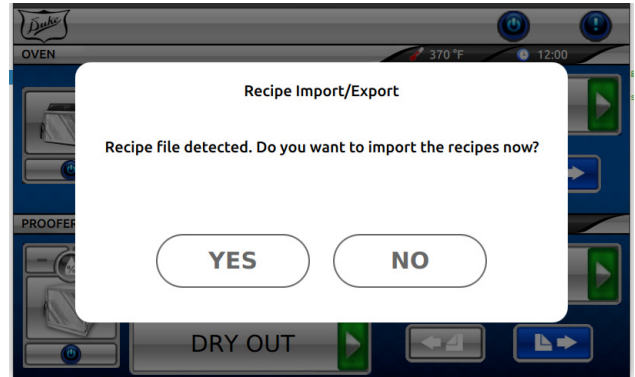
3. Once recipe export completes, a "Recipe Import/Export Complete" pop-up message will appear. Press the "OKAY" button and the pop-up message will dismiss.



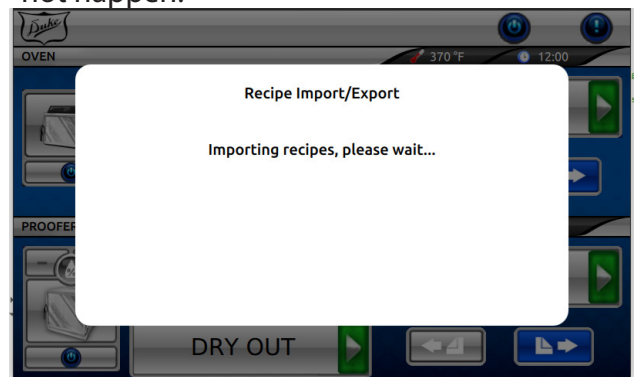
4. Remove the USB drive from the USB port on the unit.

Recipe Import

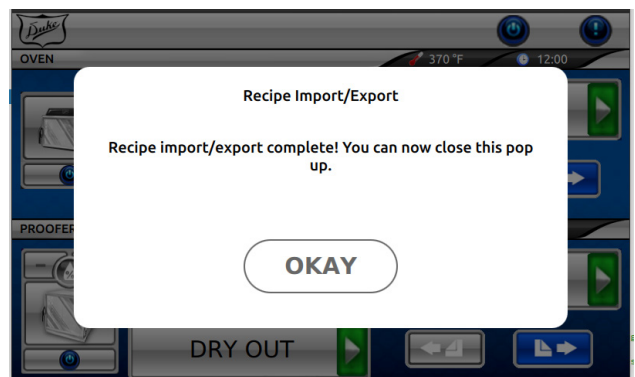
1. With the unit powered on, insert a USB drive, containing a recipe file (recipe.pbc), into the USB port on the front of the unit. A "Recipe File Detected" pop-up message will appear.



2. Press the "YES" button to start the recipe import to the unit and an "Importing Recipes" pop-up message will appear. If you press the "NO" button instead, the "Recipe File Detected" pop-up message will dismiss and recipe import will not happen.



3. Once recipe import completes, a "Recipe Import/Export Complete" pop-up message will appear. Press the "OKAY" button and the pop-up message will dismiss.



4. Remove the USB drive from the USB port on the unit.

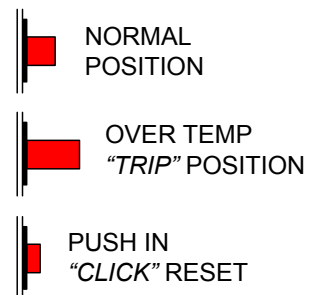
TROUBLESHOOTING

PROBLEM	YES	NO
<p>1. Oven does not heat with oven switch in the ON position and Oven Temperature not set at 0°.</p> <p>a. Are oven indicator lights on?</p> <p>b. Does Oven Fan work?</p> <p>c. Is Oven Door Securely closed?</p> <p>d. Is Supply Circuit Breaker tripped?</p> <p>e. Does oven work?</p>	<p>Observe Oven Fan. Go to "b".</p> <p>Call Duke Service.</p> <p>Call Duke Service.</p> <p>Reset Circuit Breaker. Try oven again. Go to "e"</p> <p>Troubleshooting complete</p>	<p>Reset Hi-limit Switch</p> <p>Check Proofer Operation. Go to "d".</p> <p>Close Door securely. Go to "e".</p> <p>Call Duke Service.</p> <p>Call Duke Service.</p>
<p>2. Proofer does not heat with Proofer Switch in the ON position</p> <p>a. Are Proofer indicator lights on?</p> <p>b. Does Proofer Fan appear to work?</p> <p>c. Does Proofer work?</p> <p>d. Is Supply Circuit Breaker tripped?</p> <p>e. Does Proofer work?</p>	<p>Observe Proofer Fan. Go to "b".</p> <p>Call Duke Service.</p> <p>Call Duke Service.</p> <p>Reset Circuit Breaker. Try Proofer again</p> <p>Troubleshooting complete.</p>	<p>Check Oven Operation. Go to "c".</p> <p>Check Oven Operation. Go to "c".</p> <p>Check Supply Circuit Breaker. Go to "d".</p> <p>Call Duke Service.</p> <p>Call Duke Service.</p>
<p>3. Oven/Proofer lights not working.</p> <p>a. Is more than one light not working?</p> <p>b. Do all lights work now?</p> <p>c. Do all lights work now?</p>	<p>If all the proofer light are not working, press light reset button on side of control panel and recheck. Go to "b"</p> <p>If various lights not working, replace inoperative bulbs with 10 watt bulbs and recheck. Go to "c"</p> <p>Troubleshooting complete.</p> <p>Troubleshooting complete.</p>	<p>Replace inoperative bulbs with 10 watt bulbs and recheck. Go to "c"</p> <p>Call Duke Service.</p> <p>Call Duke Service.</p> <p>Call Duke Service.</p>
<p>4. Proofer Humidity not working/ insufficient with Humidity Control not set to Off.</p> <p>a. Does there appear to be a light fog moisture on. Wait 15 minutes. Go to "b"</p> <p>b. Does Proofer Fan appear to work?</p> <p>c. Confirm water supply to unit is on.</p> <p>d. Check for restrictions in water line. (Kinks in water line, Clogged filter or inlet strainer)</p>	<p>Decrease humidity if too much moisture on the Proofer door?</p> <p>Go to "c".</p> <p>Go to "d".</p> <p>Troubleshooting complete.</p>	<p>Increase humidity if not enough on proofer door. Go to "b" Proofer door.</p> <p>Call Duke Service</p> <p>Turn water supply on. Go to "d".</p> <p>Call Duke Service.</p>

A Manually reset high temperature safety limit is provided on the right side of the control section of the unit to protect the oven elements. The high limit will not trip under normal operating conditions. Should the oven high limit trip, push the RESET button. The high limit will reset with a "click" if an over temperature trip occurred. If condition persists, call Duke Service.

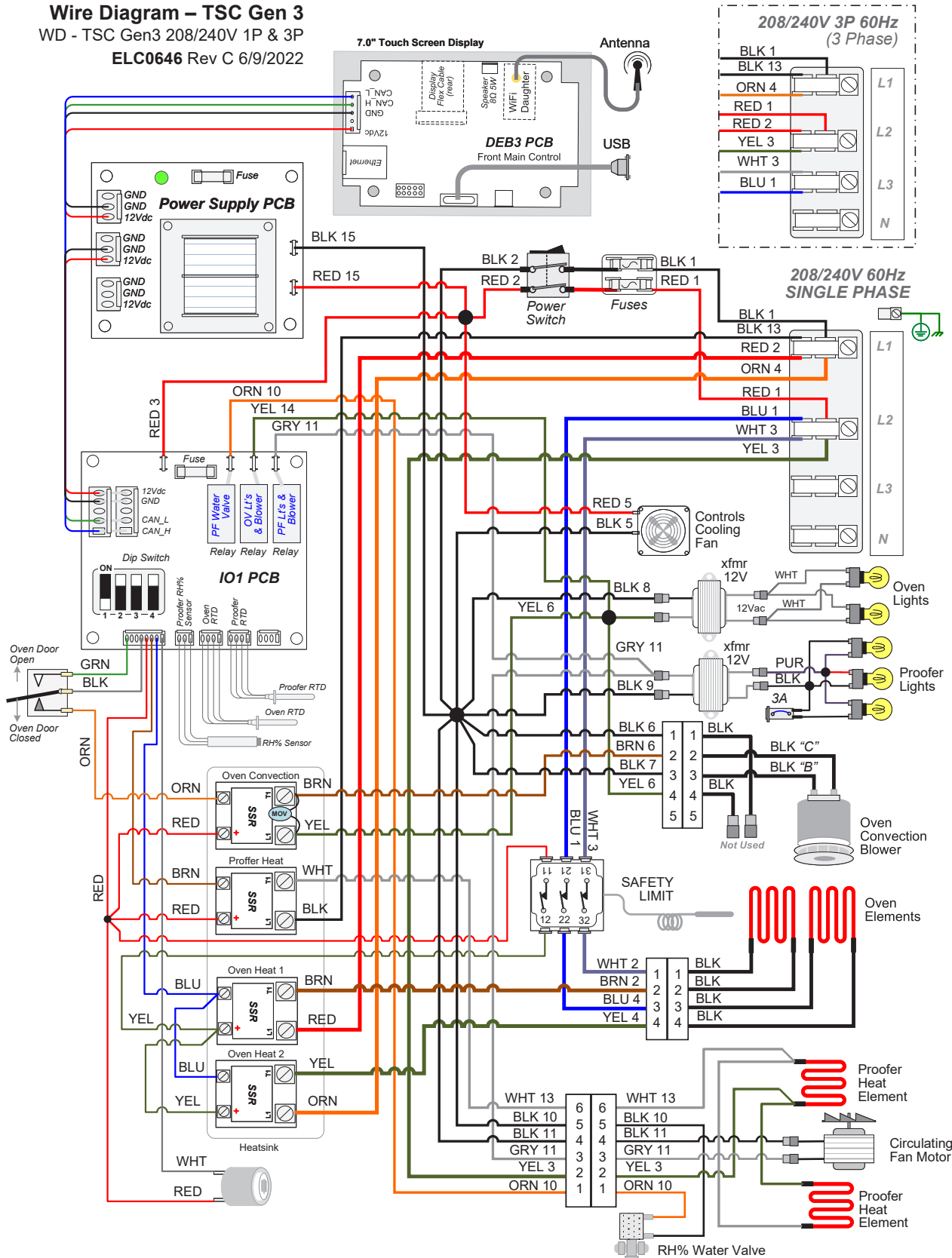
HIGH LIMIT PROTECTOR FOR OVEN ELEMENTS

LOACTED ON RIGHT SIDE OF CONTROLS SECTION



WIRING DIAGRAM FOR AUTHORIZED PERSONNEL ONLY

Wire Diagram – TSC Gen 3
 WD - TSC Gen3 208/240V 1P & 3P
 ELC0646 Rev C 6/9/2022



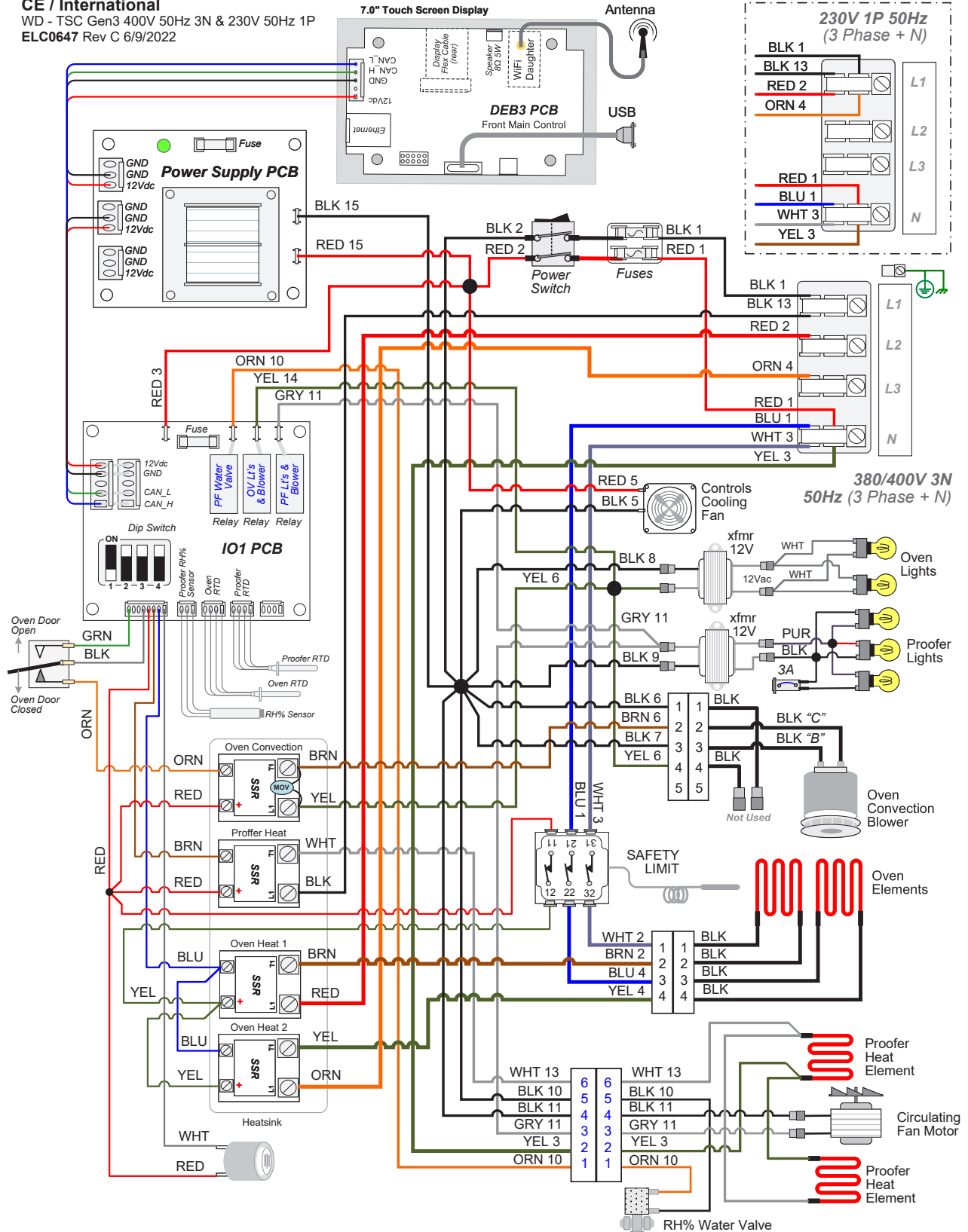
WIRING DIAGRAM FOR AUTHORIZED PERSONNEL ONLY

Wire Diagram - TSC Gen3

CE / International

WD - TSC Gen3 400V 50Hz 3N & 230V 50Hz 1P

ELC0647 Rev C 6/9/2022





Duke Manufacturing Co.
2305 N. Broadway
St. Louis, MO 63102

Phone: 314-231-1130
Toll Free: 1-800-735-3853
Fax: 314-231-5074

www.dukemfg.com