

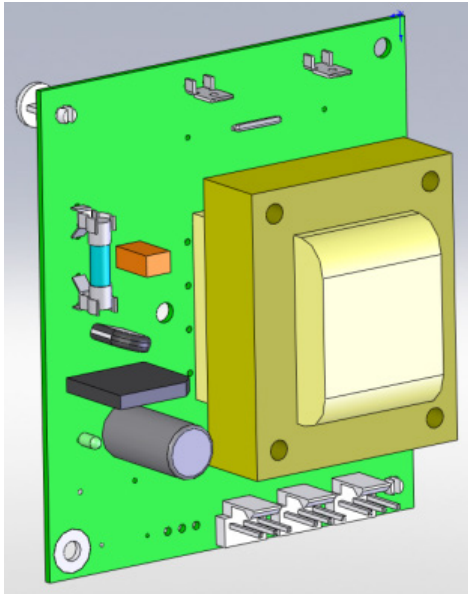

Your Solutions Partner

Installation Instructions

POWER SUPPLY PCB REPLACEMENT



This kit contains:

- PCB, 12V Power Supply Board
- [512418](#) Strap, Disposable Wrist ESD

Items required for this installation:

- #2 Phillips Screw Driver
- ESD Wrist Strap (included in kit)

CAUTION: Please read this manual completely before attempting to install, operate or service this equipment

*This manual is Copyright © 2019 Duke Manufacturing Co. All rights reserved.
Reproduction without written permission is prohibited. Duke is a registered
trademark of the Duke Manufacturing Co.*

**P/N 120111
REV D 01/28/2019**

Replacement Instructions

Step 1

Verify the PCB Power Assembly requires replacement prior to proceeding.

⚠ WARNING HAZARDOUS VOLTAGE
⚠ CAUTION RISK OF ELECTRIC SHOCK

Step 2

Turn OFF the unit's Power.
Disconnect unit from Mains Supply Voltage using lockout / tagout procedures.

Reference: LOCKOUT / TAGOUT PROCEDURE

- The worker shall check to be sure that no one is operating the machinery BEFORE turning off the power. The machine operator shall be informed before the power is turned off. Sudden loss of power could cause an accident.
- All energy sources that could activate the machine shall be locked out (blocked/tagged).
- The main valve or main electrical disconnect shall be tested to be sure that the power to the machine is off.
- Electrical circuits shall be checked with proper and calibrated electrical testing equipment. An electrical failure could energize the equipment even if the switch is in the off position.

Step 3

Obtain access to panel where power module is to be replaced.

Step 4

Place ESD strap on wrist and tighten. Strap must be tight around wrist to be effective.

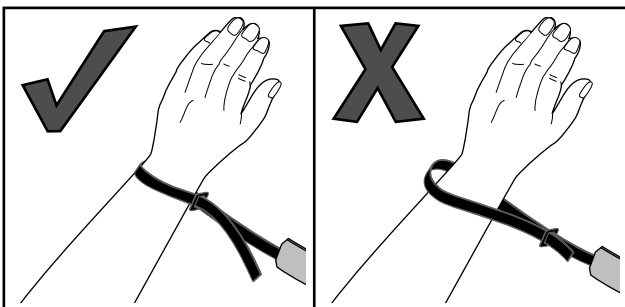

Step 4

Secure ESD Wrist strap to the main structure of the equipment.

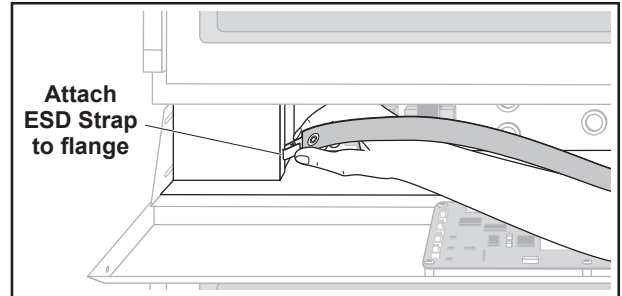

Step 5

The PCB Power Assembly is mounted vertically. Disconnect the Quick Connect terminals from the PCB. The black and red wires are the line voltage line supply connector to the PCB Power Assembly. Disconnect the two 2-wire PCB header connectors at the low voltage connections. These connections are the 12VDC output of the PCB Power Assembly.

Note: Orientation of the PCB may differ based on model.

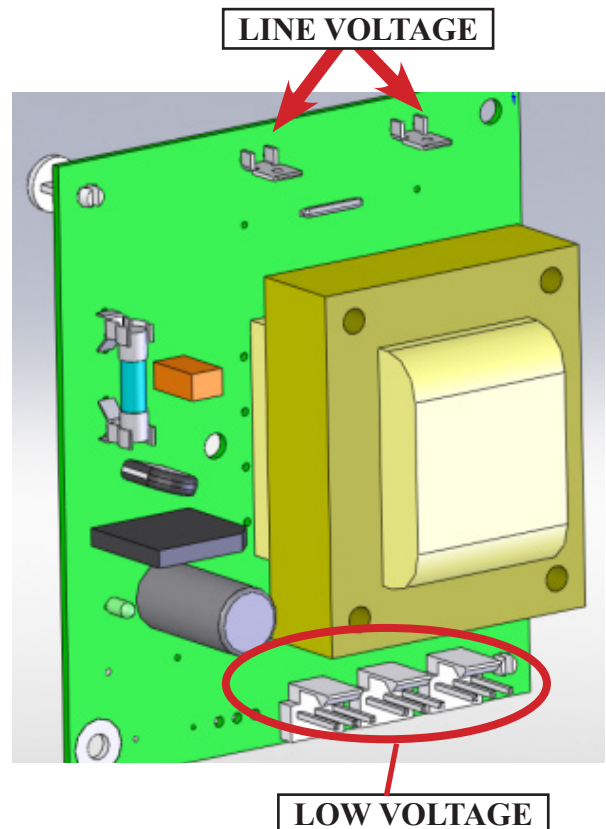

Replacement Instructions - continued



Remove Two Screws

Step 6

The PCB Power Assembly is mounted with 2 screw standoffs and two keyhole standoffs. Remove the 2 standoff screws and lift the PCB slightly vertical to free the remaining keyhole standoffs to remove the PCB.

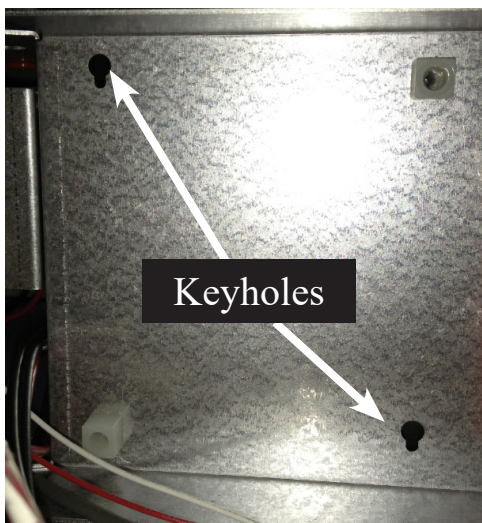

Step 7

Using proper ESD procedures, remove the new PCB Power Assembly from the shipping packaging, align the keyhole standoffs on the new PCB Power Assembly with the vertical panel mounting holes, allow the keyhole standoffs to drop down and seat, and reinstall the screws in the remaining standoffs.

Step 8

Reconnect the two 2-wire PCB header connectors to the low voltage connections of the PCB and the black and red wire Quick Connects to high voltage of the PCB.

Step 9

Re-install the access panel.

Step 10

Reconnect line power to the unit (Reference Tagout process) and turn On the power switch.

Step 11

Verify the unit functions normally by starting the unit and, verifying no fault messages are displayed. Allow the unit to complete a couple of cycles.

NOTES



Duke Manufacturing Co.
2305 N. Broadway
St. Louis, MO 63102

Phone: 314-231-1130
Toll Free: 1-800-735-3853
Fax: 314-231-5074

www.dukemfg.com