

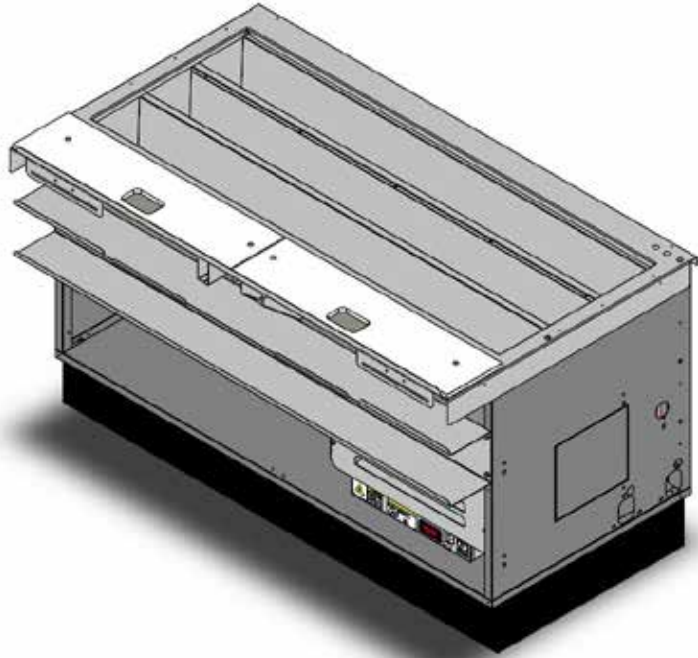

Your Solutions Partner

# Illustrated Parts List



## TRI-CHANNEL COLD PAN

### R-290 ASSEMBLIES:

2504502 2504503 2504504 2504505 2504506  
2504507 2504509 2504511 2504522 2504523  
2504524 2504525 2504526 2504527 2504529  
2504531

---

*This manual is Copyright © 2020 Duke Manufacturing Co. All rights reserved.  
Reproduction without written permission is prohibited. Duke is a registered  
trademark of the Duke Manufacturing Co.*

## **Duke Manufacturing Co.**

**2305 N. Broadway • St. Louis, MO 63102**

**800.735.3853 • 314.231.1130**

**Fax: 314-231-5074**

**[www.dukemfg.com](http://www.dukemfg.com)**



## TABLE OF CONTENTS

TRI-CHANNEL ASSEMBLY .....	4
R-290 TRI-CHANNEL MECHANICAL ASSEMBLY .....	6
CONTROL BOX ASSEMBLY .....	8
516827 - EMERSON CONDENSING UNIT, 220/240V 50HZ, R290 REFRIGERANT .....	9
516817 - TECUMSEH CONDENSING UNIT, 220/240V 50HZ, R-290 REFRIGERANT .....	10
516818 - TECUMSEH CONDENSING UNIT, 220/240V 50HZ, R-290 REFRIGERANT .....	11
WIRE DIAGRAM - TRI-CHANNEL 230V 50HZ, (R290).....	12
FLOW DIAGRAM - R290 REFRIGERANT.....	13

# TRI-CHANNEL ASSEMBLY

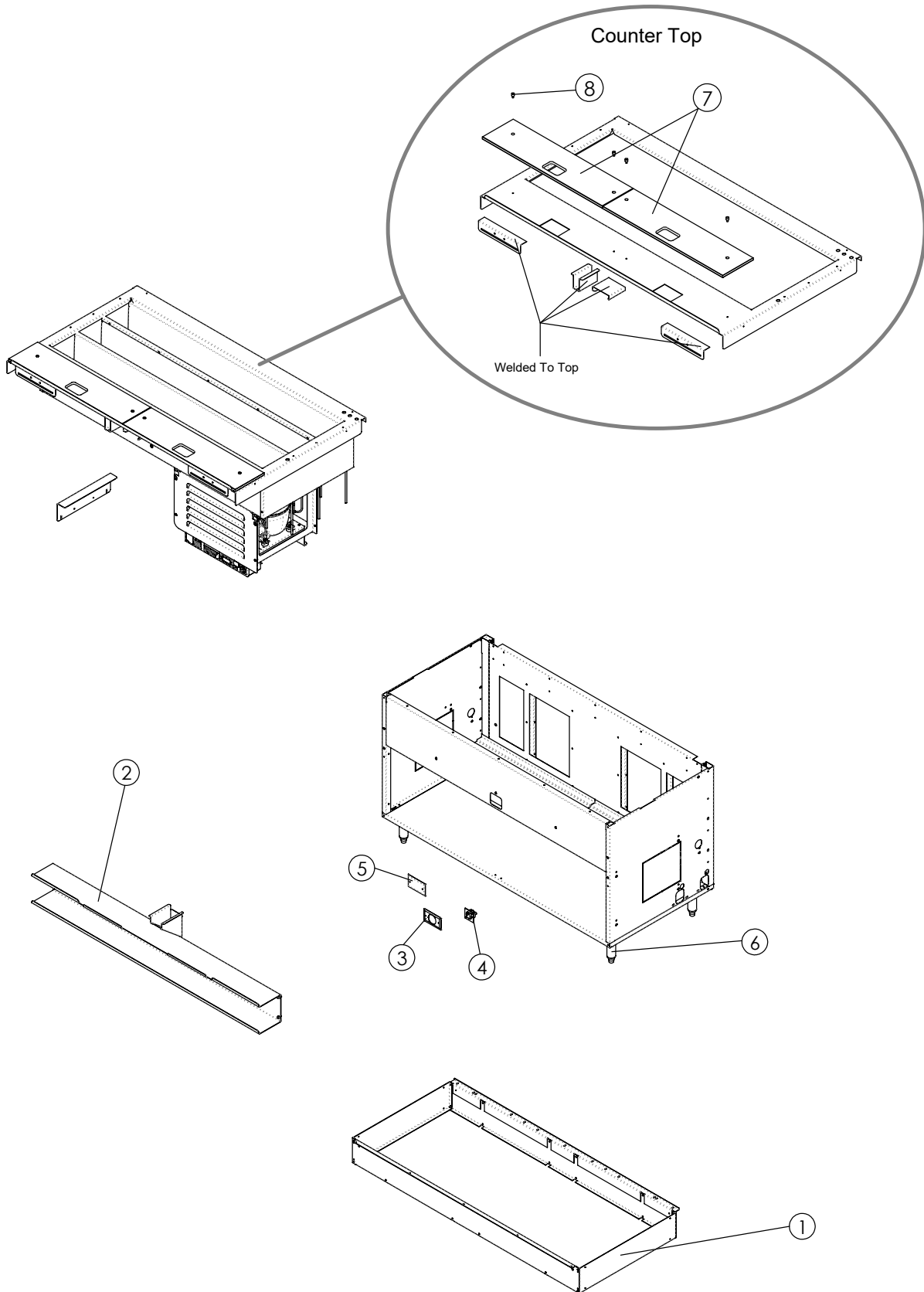

## TRI-CANNEL ASSEMBLY

ITEM #	PART #	DESCRIPTION	36" Units	48" Units	60" Units	74" Units	86" Units
1	<a href="#">RS000234</a>	KICKPLATE TUS 36 CFG 36L X 30D	1				
	RS000235	KICKPLATE TUS 48 CFG 48L X 30D		1			
	RS000236	KICKPLATE TUS 60 CFG 60L X 30D			1		
	RS000239	KICKPLATE TUS 74 CFG 74L X 30D				1	
	RS000240	KICKPLATE TUS 86 CFG 86L X 30D					1
2	RS039804	BAIN FUNC SHELF ASSY 36	1				
	RS022480	BAIN FUNC SHELF ASSY 48		1			
	<a href="#">RS022481</a>	BAIN FUNC SHELF ASSY 60			1		
	RS022482	BAIN FUNC SHELF ASSY 74				1	
	RS022483	BAIN FUNC SHELF ASSY 86					1
3	254463	COVER OUTLET 220V CEE7	1	1	1	1	1
4	222153	SOCKET, 16A 250V, SCHUKO	1	1	1	1	1
5	222178	COVER, BOX NYLON BLANK 2 X 4	1	1	1	1	1
6	<a href="#">214556</a>	LEG, 6" ADJ PLATE MT GALV	4	4	4	6	6
Not Shown	<a href="#">213023</a>	LEG SCREW, 1/4-20 X 1/2" TRD FRM	16	16	16	24	24
7	RS048497	BOARD CARV 36" FUNC METRO SUBWAY BAIN	1				
	RS048498	BOARD CARV 48" FUNC SUBWAY BAIN		1			
	RS048551	BOARD CARV 60" FUNC SUBWAY BAIN			2		
	RS048499	BOARD CARV 74" FUNC SUBWAY BAIN				2	
	RS048500	BOARD CARV 86" FUNC SUBWAY BAIN					2
8	<a href="#">214728</a>	STUD, POSITION SS CARV BRD SET SCREW LENGTH- 5/8"	2	2	4	4	4

## R-290 TRI-CHANNEL MECHANICAL ASSEMBLY

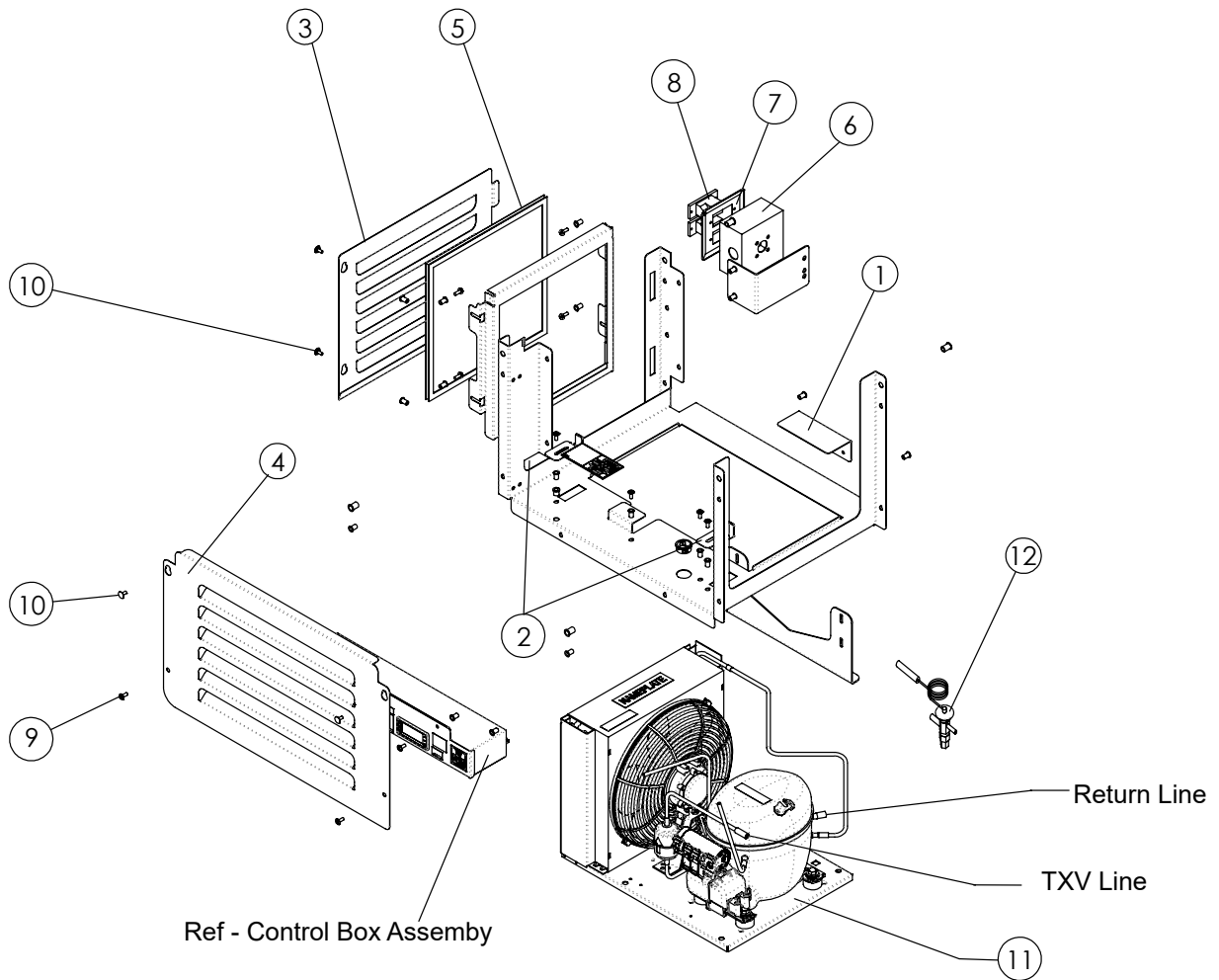

## R-290 TRI-CHANNEL MECHANICAL ASSEMBLY

ITEM #	PART #	DESCRIPTION	36" Units	48" Units	60" Units	74" Units	86" Units
1	E100043	BRACKET, CONDENSING UNIT	1	1	1	1	1
2	E100042	BRACKET, CONDENSING UNIT HOLDER	2	2	2	2	2
3	E100029	PANEL, LOUVER FILTER, R-290 TRI CHANNEL	1	1	1	1	1
4	E100030	PANEL, LOUVER OPERATOR , R-290 TRI CHANNEL	1	1	1	1	1
5	524809	FILTER, R-290 TRI-CHANNEL	1	1	1	1	1
6	212134	ELECTRICAL BOX, 4 X 4 X 2-1/8"	1	1	1	1	1
7	251898	COVER PLATE, 220V ELECTRIC BOX	1	1	1	1	1
8	212307	RECEPTACLE, SINGLE, EUROPEAN 220V 2 PRONG	2	2	2	2	2
9	<a href="#">213027</a>	SCREW, 10-24 X 1/2" PTHMS S/S	10	10	10	10	10
10	<a href="#">214486</a>	STUD, COVER SS THREADED PIN	4	4	4	4	4
11	516827	EMERSON COND. UNIT, 220/240V 50HZ R-290 REFRIGERANT, MUZP-0039-1AZ-321 <b>(Additional Information on page 9)</b>	1	1	1		
	516817	TECUMSEH COND. UNIT, 220/240V50HZ R-290 REFRIGERANT, AEX419U-FZ1CCK <b>(Additional information on page 10)</b>	1	1	1		
	516818	TECUMSEH COND. UNIT, 220/240V50HZ R-290 REFRIGERANT, AXE424U-FZ3BCK <b>(Additional information on page 11)</b>				1	1
12	516829-41K	SERVICE KIT, TXV, 41PSIG	1	1			
	516829-45K	SERVICE KIT, TXV, 45PSIG			1	1	1

## CONTROL BOX ASSEMBLY

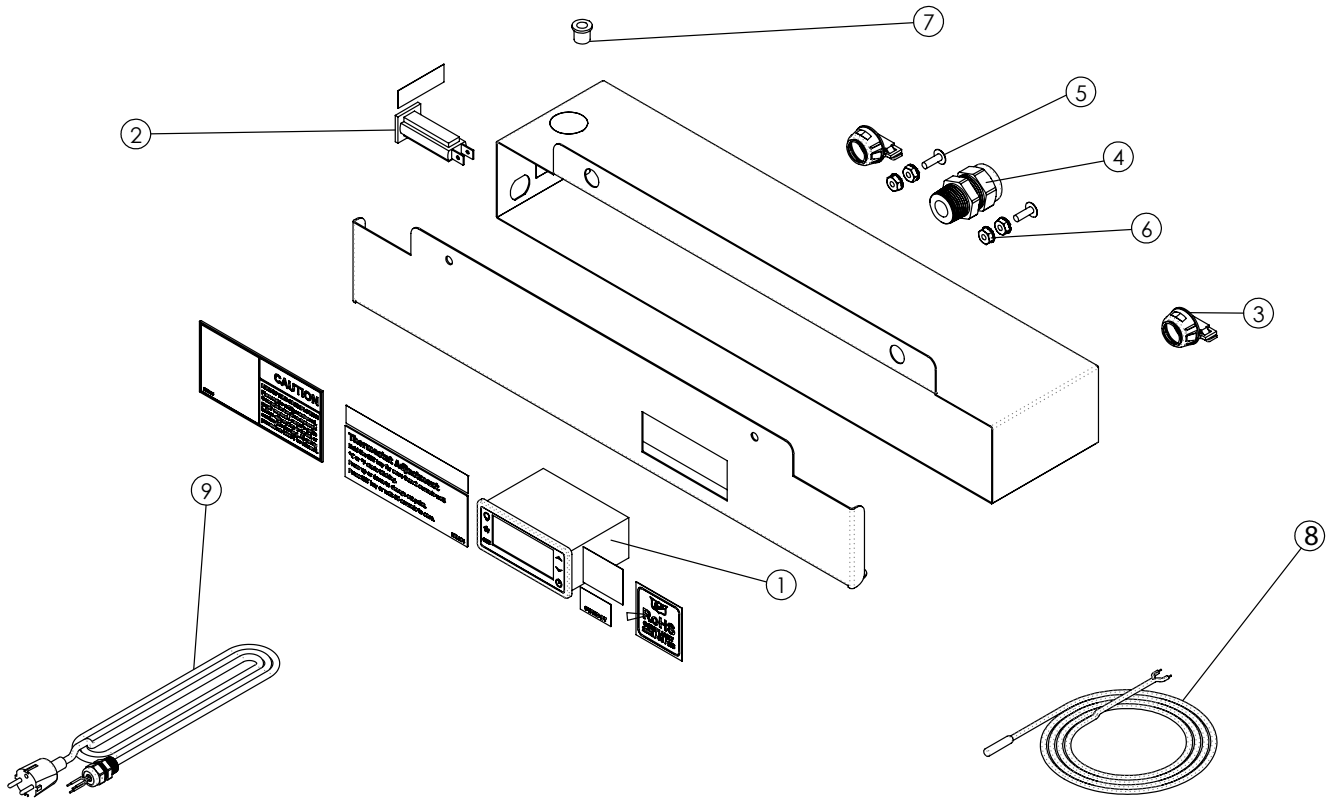

ITEM #	PART #	DESCRIPTION	36" Units	48" Units	60" Units	74" Units	86" Units
1	526840-AK	CUSTOM PROGRAMMED CONTROL, DIXELL XR20CH, KIT	1	1	1	1	1
2	<a href="#">212309</a>	CIRCUIT BREAKER COLD - 2 AMP	1	1	1	1	1
3	212020	CONNECTOR, 3/8"	2	2	2	2	2
4	<a href="#">175515</a>	STRAIN RELIEF,POWER CORD INCLUDES NUT	1	1	1	1	1
5	213359	SCREW, 8-32 X 1/2 THRUSS PHILLI S/S	2	2	2	2	2
6	<a href="#">155680</a>	NUT, KEPS 8-32 HEX ZP	4	4	4	4	4
7	212102	BUSHING, HEYCO #2030 SB 375-4	1	1	1	1	1
8	526841-K	KIT, TEMPERATURE PROBE R-290 <i>(Used with 526840)</i>	1	1	1	1	1
9	2504639-K	KIT, CORD & PLUG, R-290 TRI-CHANNEL <i>(Control to Wire Chase)</i>	1	1	1	1	1

## 516827 - EMERSON CONDENSING UNIT

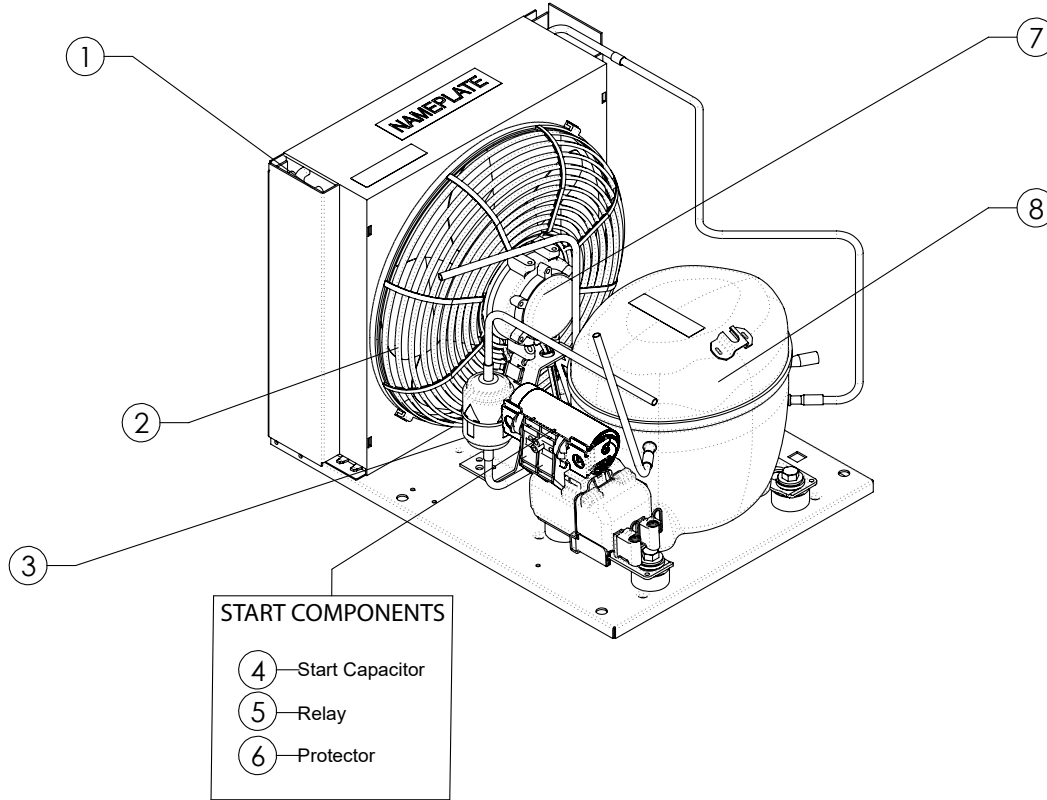

516827 Emerson Condensing Unit, 220/240V, 50Hz, R-290 Refrigerant

ITEM #	PART #	DESCRIPTION	36" Units	48" Units	60" Units	74" Units	86" Units
1	527910	CONDENSER COIL (Ref - 516827)	1	1	1		
2	527907	CONDENSER FAN BLADE (Ref - 516827)	1	1	1		
3	227869	FILTER, DRYER (Ref - 516827)	1	1	1		
4	527916	COMPRESSOR START COMPACITOR (Ref - 516827)	1	1	1		
5	527913	RELAY (Ref - 516827)	1	1	1		
6	527919	PROTECTOR (Ref - 516827)	1	1	1		
7	527905	CONDENSER FAN MOTOR (Ref - 516827)	1	1	1		
8	527901	COMPRESSOR, AFF12C1U-IAZ (Ref - 516827)	1	1	1		

## 516817 - TECUMSEH CONDENSING UNIT

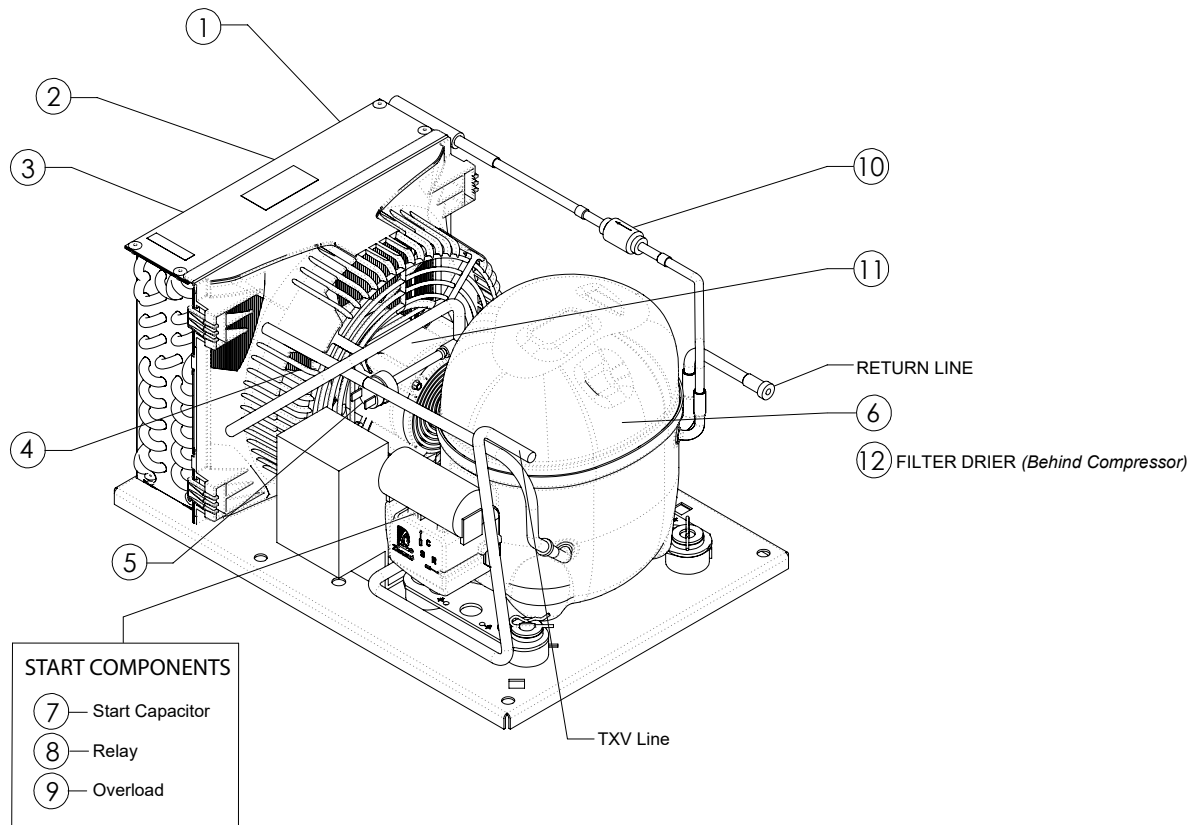

516817 Tecumseh Condensing Unit, 220/240V, 50Hz, R-290 Refrigerant

ITEM #	PART #	DESCRIPTION	36" Units	48" Units	60" Units	74" Units	86" Units
1	527821	KIT, FAN GUARD SHROUD, COND. COIL (Ref-516817 & 516818)	1	1	1		
2	527822	FAN GUARD SHROUD (Ref-516817 & 516818)	1	1	1		
3	527823	CONDENSER COIL (Ref-516817 & 516818)	1	1	1		
4	527827	FAN BLADE (Ref-516817 & 516818)	1	1	1		
5	227868	HIGH PRESSURE SWITCH (Ref-516817 & 516818)	1	1	1		
6	527820	COMPRESSOR, AE1918E-679-J7 (Ref-516817)	1	1	1		
7	527824	START CAPICATOR (Ref-516817)	1	1	1		
8	527825	RELAY (Ref-516817)	1	1	1		
9	527828	OVERLOAD (Ref-516817)	1	1	1		
10	527894	CHECK VALVE (Ref-516817 & 516818)	1	1	1		
11	527826	MOTOR, FAN (Ref-516817 & 516818)	1	1	1		
12	227867	FILTER, DRYER (Ref-516817 & 516818)	1	1	1		

## 516818 - TECUMSEH CONDENSING UNIT

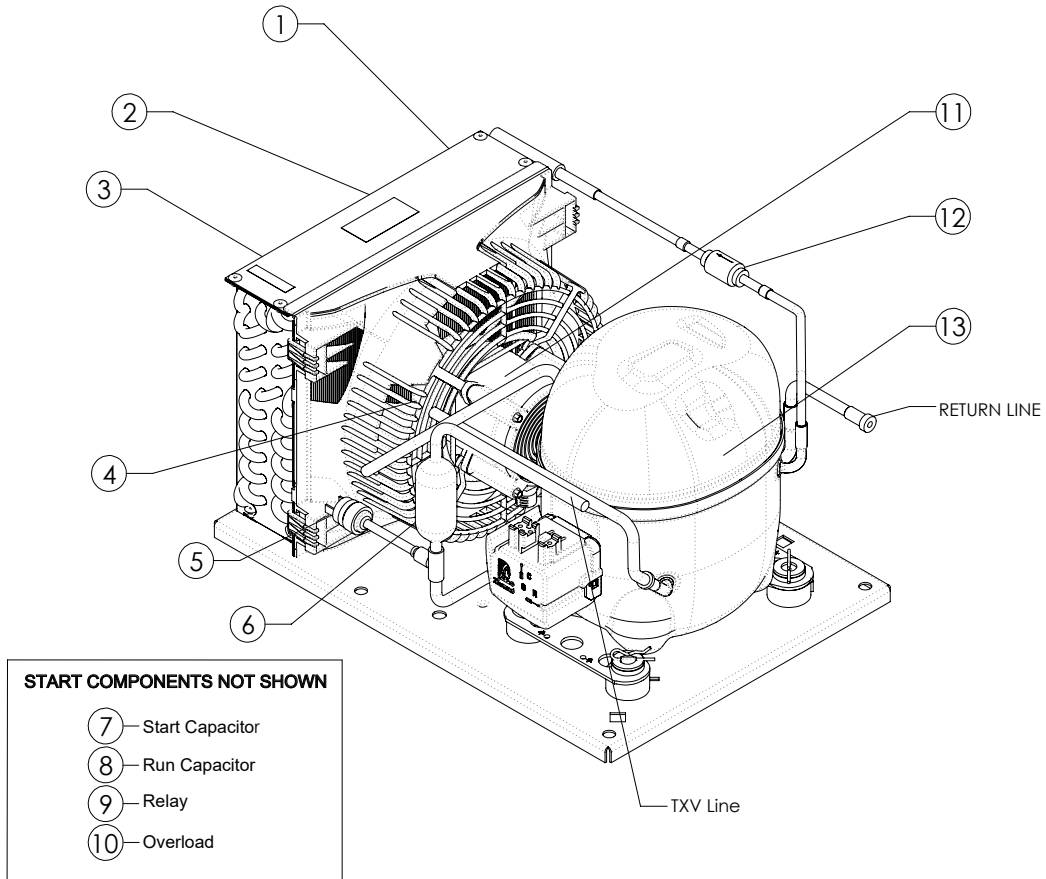





516818 Tecumseh Condensing Unit, 220/240V, 50Hz, R-290 Refrigerant

ITEM #	PART #	DESCRIPTION	36" Units	48" Units	60" Units	74" Units	86" Units
1	527821	KIT, FAN GUARD SHROUD, COND. COIL (Ref-516817 & 516818)				1	1
2	527822	FAN GUARD SHROUD (Ref-516817 & 516818)				1	1
3	527823	CONDENSER COIL (Ref-516817 & 516818)				1	1
4	527827	FAN BLADE (Ref-516817 & 516818)				1	1
5	227868	HIGH PRESSURE SWITCH (Ref-516817 & 516818)				1	1
6	227867	FILTER, DRYER (Ref-516817 & 516818)				1	1
7	527852	CAPICATOR, START (Ref-516818)				1	1
8	527853	CAPICATOR, RUN (Ref-516818)				1	1
9	527854	RELAY (Ref-516818)				1	1
10	527855	OVERLOAD (Ref-516818)				1	1
11	527826	MOTOR, FAN (Ref-516817 & 516818)				1	1
12	527894	CHECK VALVE, (Ref-516817 & 516818)				1	1
13	527851	COMPRESSOR, AE1902E-208-J7 (Ref-516818)				1	1



## FLOW DIAGRAM - R290 REFRIGERANT

# TRI-CHANNEL, R290 REFRIGERATION SYSTEM

-  High Pressure Gas
-  High Pressure Liquid
-  Low Pressure Liquid
-  Low Pressure Gas

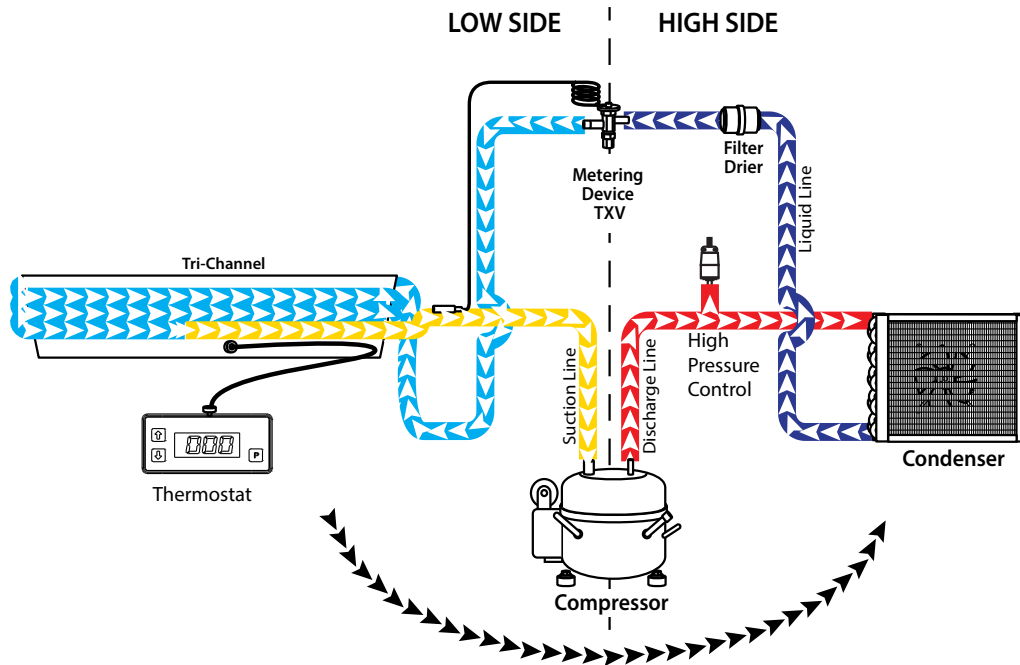

Tri-Channel (R290 Refrigerant)	
Voltage	208-230v 60hz 220/240 50hz
Control	Dixell XR20CH R-290 Controller
Probe	Dixell XR20CH Probe
36"	90 grams
48"	90 grams
60"	110 grams
74"	110 grams
86"	140 grams
Super Heat	4-10°
Sub Cooling	10-15°
High Pressure Range @75°	170-190 psig
Low Pressure Range @75°	20-40 psig
36-60"	
LRA	18.3
RLA	2.3
74-86"	
LRA	17.5
RLA	1.8
Condenser Fan	0.27
HPCO	Cut out 450 psi
<b>(Tecumseh Units Only)</b>	Cut In 280 psi

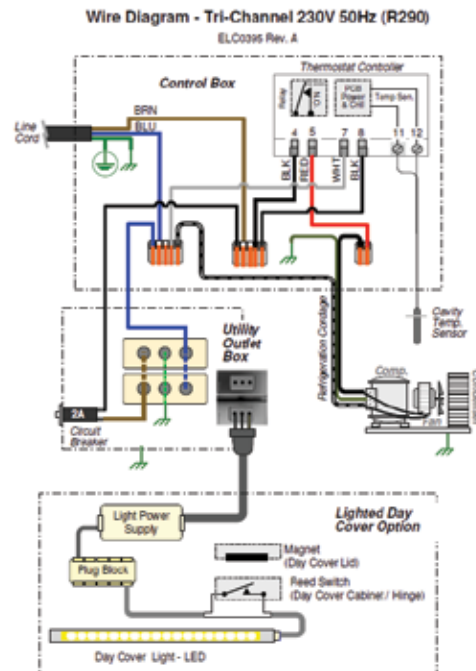



Your Solutions Partner

## **Duke Manufacturing Company**

**2305 N. BROADWAY  
ST. LOUIS, MO 63102  
PHONE: 314-231-1130  
TOLL FREE: 1-800-735-3853  
FAX: 314-231-5074  
WWW.DUKEMFG.COM**