



CARRIER COMMERCIAL REFRIGERATION, INC.

Providing BEVERAGE-AIR • FRIGIDAIRE • KELVINATOR • UNIVERSAL NOLIN Products/Services

SERVICE & INSTALLATION MANUAL

Baskin *31* Robbins®

**ICE CREAM
DIPPING
CABINETS**
R-404A Refrigerant

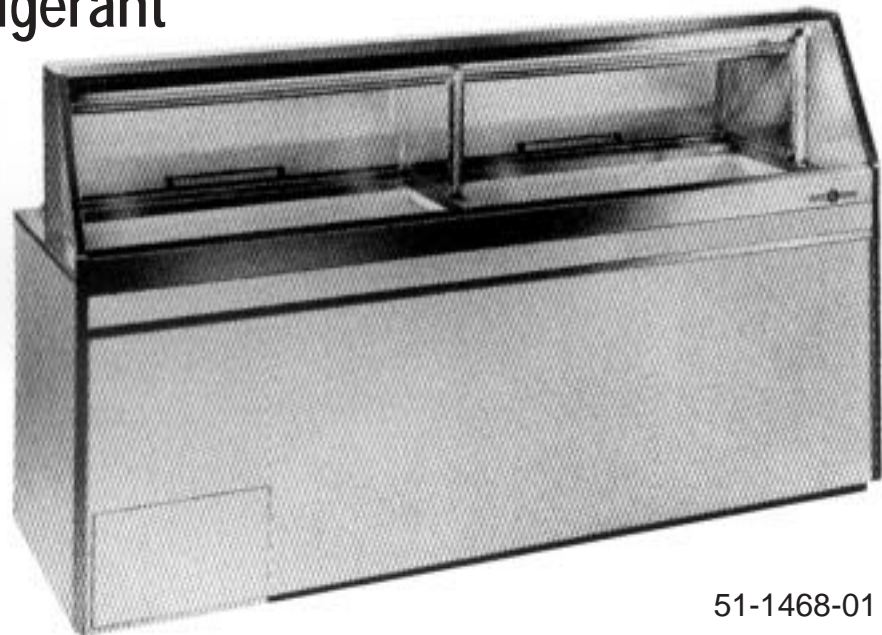

1/2003

51-1468-01

If additional information is necessary, call the factory.

Our toll free number is **1-800-684-1199**. Technical assistance engineers are willing to assist you in any way possible. Office hours are from 8:00a.m. to 5:30 p.m., Eastern Standard Time.

Important information is contained in this manual which should be retained in a convenient location for future reference.

MODEL DESIGNATION INFORMATION		
115V, 60HZ		
PART #	MODEL #	DATA PLATE
52-1961-35	BRT-68	BRT68
52-2077-02	BRT68P	BRT68
52-2077-04	BRT68W	BRT68
52-1961-36	BRT90	BRT90
52-2077-03	BRT90P	BRT90
52-2077-05	BRT90W	BRT90
EXPORT 220V, 50HZ		
PART #	MODEL #	DATA PLATE
52-1961-31	EBRT-68	EBRT68
52-1961-41	EBRT68P	EBRT68
52-1961-32	EBRT90	EBRT90
52-1961-42	EBRT90P	EBRT90
EXPORT 220V, 60HZ		
PART #	MODEL #	DATA PLATE
52-1961-33	KBRT-68	KBRT68
52-1961-34	KBRT90	KBRT90

SECTION I

Introduction

blank

Dipping Cabinets - Introduction

These Dipping Cabinets are designed to merchandise ice cream or yogurt-type products. Dipping cabinets are produced in three sizes: 8, 12, and 16 facings of ice cream containers. The cabinet systems contain CFC free refrigerant, metered into the system by a capillary tube. The evaporator is a cold wall which has the refrigerant lines strapped to the inner liner of the cabinet. The condenser is a bare tube mounted on a pullout machinery compartment tray for ease of servicing. All electrical controls are easily accessible for repair. The temperature within the cabinet is controlled thermostatically, allowing for maintenance of correct dipping temperatures.

Mechanical equipment may require repair at times. This manual presents information that is helpful in maintaining, diagnosing, and repairing these cabinets.

The high level of quality built into these units will allow for many years of trouble-free operation.

TABLE OF CONTENTS

INTRODUCTION

Introduction	3
Table of Contents	4
Cabinet Specifications / Dimensional Data: BRT-68	5
Cabinet Specifications / Dimensional Data: BRT-90	6
Handling & Installation	7

PRINCIPLES OF OPERATION

General Information - Refrigeration Systems	11
BRT-68 Electrical & Refrigeration Information	13
BRT-90 Electrical & Refrigeration Information	14
EBRT-68 & KBRT-68 Electrical & Refrigeration Info	15
EBRT-90 & KBRT-90 Electrical & Refrigeration Info	16
BRT-68 & BRT-90 Wiring Diagram	17
EBRT/KBRT-68 & 90 Wiring Diagram	18

MAINTENANCE & REPAIR

Pre-Service Check List	21
General Maintenance Information	22
Compressor Installation / Diagnostics	24
Cleaning & Maintenance	26
Cleaning the Lid	27
Lid Seal Replacement	28
Lid Gasket Replacement	29
Lid Pivot Bushing Assembly Replacement	30
Center & End Pivot Rod Replacement	31
Fluorescent Lamp Holder/Light Starter Socket Replac.	32
Fluorescent Bulb & Starter Replacement	33
Thermostat Replacement	34
Master Power Supply Switch / Light Switch Removal	35
Condenser Fan Motor Replacement	36
Ballast Replacement	37
Metering Device / Heat Exchanger Replacement	38
Cabinet Troubleshooting Guide	39
Compressor Troubleshooting Guide	42
Fluorescent Lamp Troubleshooting Guide	45

PARTS LISTS

Cabinet Parts	48
Lamp Assembly Parts	50
Condensing Unit Parts	52
Electrical Parts	54
Lid Parts	56

Due to Frigidaire's policy of continuous quality improvement, specifications are subject to change without notice.

CABINET SPECIFICATIONS

	BRT68	EBRT68	KBRT68
Temp. Range	+10°F to -8°F		
Capacity	19.1 Cu. Ft.		
Capacity (3 Gal. Tubs)	20		
Facings (3 Gal. Tubs)	12		
Storage (3 Gal. Tubs)	8		
Compressor Size	1/3 Hp.	3/4 Hp.	3/4 Hp.
Shipping Weight (App.)	644 lbs.		
Condenser Type	Bare Tube		
Evaporator Type	Cold Wall - Refrigerated Cross Bars		
Refrigerant	R-404A		
Refrigerant Control	Capillary Tube		
Defrost System	Manual		
Rated Amps	8.0	4.1	4.1
Electrical Specs.	115V, 60 Hz., 1 Ph.	220V, 50 Hz., 1Ph	220V, 60 Hz., 1 Ph.
Power Cord	No. 16AWG		
NSF Listing	NSF1		
Canopy Construction	S.S. Top with Glass Ends Straight or Curved Front Glass		
Lids (Plexiglass)	2 Lids		
Interior Finish	White Baked Enamel on Galvanized Steel		
Exterior Finish	White Baked Enamel		
Lighting	Two 40 Watt Bulbs		

DIMENSIONAL DATA

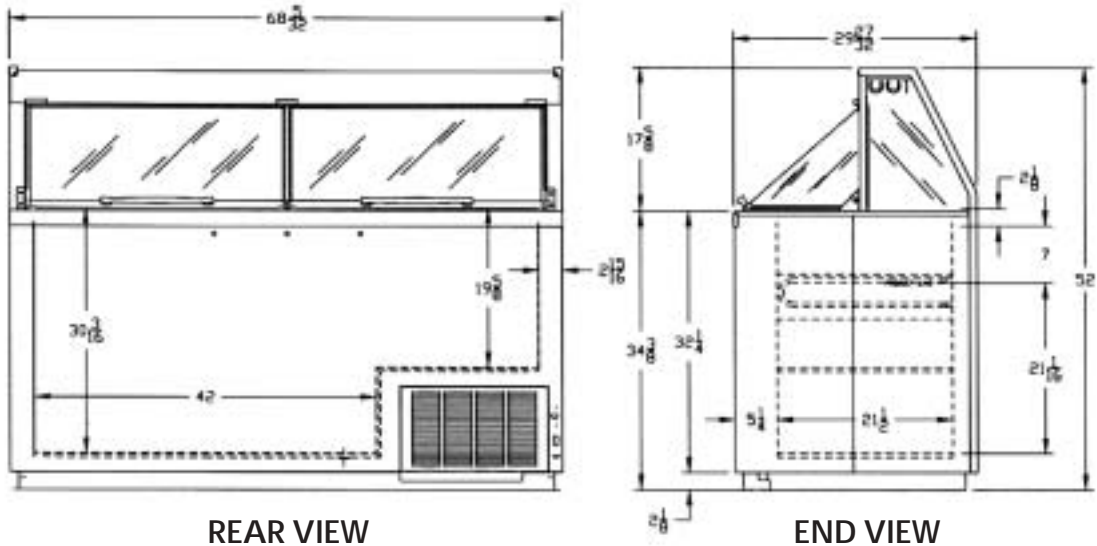

CABINET SPECIFICATIONS

	BRT90	EBRT90	KBRT90
Temp. Range	+10°F to -8°F		
Capacity	24.4 Cu. Ft.		
Capacity (3 Gal. Tubs)	28		
Facings (3 Gal. Tubs)	16		
Storage (3 Gal. Tubs)	12		
Compressor Size	1/3 Hp.	3/4 Hp.	3/4 Hp.
Shipping Weight (App.)	754 lbs.		
Condenser Type	Bare Tube		
Evaporator Type	Cold Wall - Refrigerated Cross Bars		
Refrigerant	R-404A		
Refrigerant Control	Capillary Tube		
Defrost System	Manual		
Rated Amps	8.0	4.1	4.1
Electrical Specs.	115V, 60 Hz., 1 Ph.	220V, 50 Hz., 1Ph	220V, 60 Hz., 1 Ph.
Power Cord	No. 16AWG		
NSF Listing	NSF1		
Canopy Construction	S.S. Top with Glass Ends Straight or Curved Front Glass		
Lids (Plexiglass)	2 Lids		
Interior Finish	White Baked Enamel on Galvanized Steel		
Exterior Finish	White Baked Enamel		
Lighting	Two 40 Watt Bulbs		

DIMENSIONAL DATA

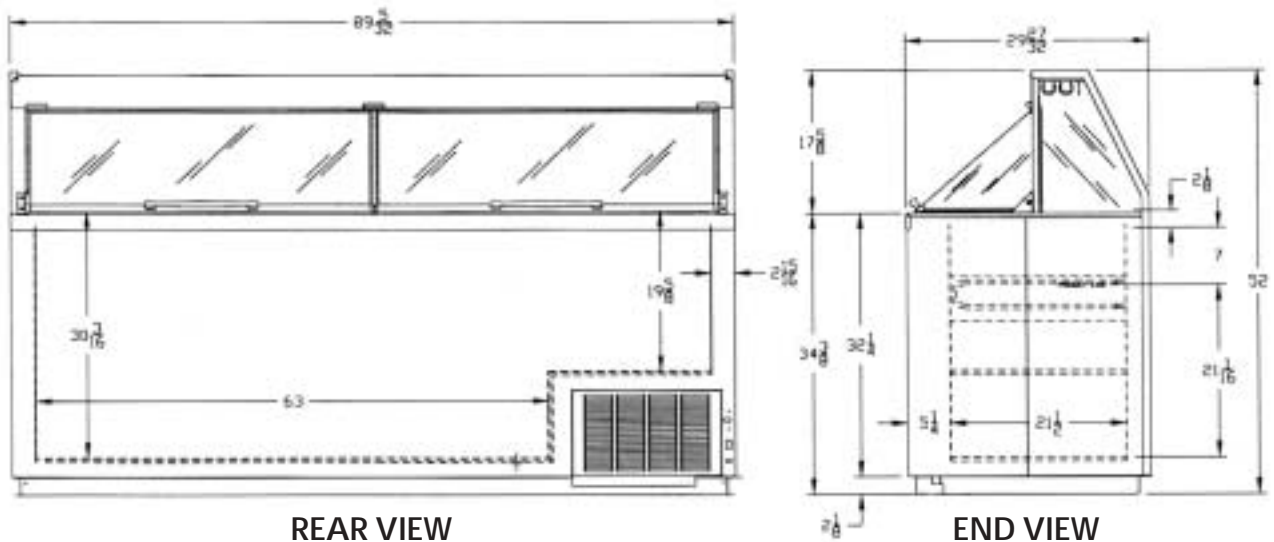

HANDLING & INSTALLATION-Illuminated Dipping Cabinets

FREIGHT DAMAGES AND SHORTAGES

IMPORTANT

The cabinet was inspected and packaged at the factory, and should have arrived in excellent condition. The transportation company or other parties involved in the shipment are responsible for loss and/or "damage." Always make an inspection before and after uncrating, preferably at the point of unloading by the transportation company.

INSPECTING FOR DAMAGES

Note:

Always use care when removing shipping tape, blocks, pads, hardware or other material. Contact your dealer or distributor if technical assistance is required.

Check the cartons or containers. If these are damaged in any way, open them and inspect the contents in the driver's presence. If damage is detected, do the following:

1. Have the driver note the nature and extent of the damage on the freight bill.
2. Notify the transportation company's office to request an inspection. Carrier claim policies usually require inspections to be made within 15 days of delivery.
3. If damage is noticed, file a claim with the transportation company.

FILING A CLAIM

File a claim for loss at once with the transportation company for:

- A. A cash adjustment B. Repairs C. Replacement

When filing your claim, retain all packaging materials and receipts.

HANDLING THE CABINET

Note:

The refrigeration system of the cabinet is designed to operate with the cabinet located on a flat surface. Do not tilt the cabinet more than 30° to any side. If the cabinet must be tilted on an angle for handling or moving purposes, allow it to sit in an upright position 20 to 30 minutes prior to operating.

CHOOSE A LOCATION

This model cabinet should be situated to allow proper air circulation. The cabinet must be installed on sturdy, level floor and positioned so that it can be plugged into a properly grounded three-prong electrical wall outlet. The electrical outlet should not be controlled by a wall switch which might be turned off accidentally.

UNCRATING THE CABINET

The cabinet should be moved as close as possible to the operating location before removing the skid. Be sure to follow the steps in the "INSPECTING FOR DAMAGES" instructions.

INSTALLING THE CABINET

Whenever possible leave the crate skid on the cabinet until it is moved close to the final position. When it is necessary to move the cabinet through a doorway, it may be necessary to remove the crate skid.

Run the cabinet down to storage temperature before adding product.

CAUTION

- A. Do not locate cabinet where sunlight or drafts from fans, air conditioners or open doors can affect product temperature.
- B. Run cabinet before building in or attaching panels or accessories.
- C. Employee side access panel must be kept clear for adjustments and service.
- D. Cabinet must be installed on the finished floor to assure rear raceway cover and condensing unit (employee side) can be pulled or removed for service. **DO NOT seal in with cover molding or caulking in the area where condensing unit pulls out.**
- E. Do not use extension cords to power this equipment.

Run any necessary electrical, water supply and drain lines before setting the cabinet in position. Shim under the cabinet as necessary to level it. N.S.F. approval requires sealing the cabinet to the floor. This can be done by applying a bead of mastic sealer between the cabinet bottom flange and the floor.

Should several cabinets be set up in a row, space is provided in the rear toe space for routing electrical and plumbing lines. Access to this space requires removing screws and the metal cover which runs the length of the cabinet.

Rivnuts are provided on the operator's side for mounting dipperwell and other accessories.

CABINET START-UP

Once the cabinet has been located in its permanent location and the proper power and grounding have been provided, the following items must be checked or completed:

- A. Cut and remove the compressor hold-down band (if applicable) so the compressor "floats" freely.

B. Check for traces of oil on the compressor pan which could mean a broken or leaking refrigeration line. **UNDER NO CIRCUMSTANCE SHOULD THE COMPRESSOR BE STARTED WHEN OIL IS PRESENT UNTIL INSPECTED BY A SERVICE TECHNICIAN.**

C. **INSPECT THE FACTORY WIRING FOR TERMINALS THAT MIGHT HAVE VIBRATED LOOSE IN SHIPPING. TIGHTEN ALL SCREW TYPE TERMINALS.**

D. Check the refrigeration lines to see that they are "free" and no damage was done during shipping.

E. Check fan blade for free operation.

F. Turn on the main power switch. Once the compressor starts, the voltage should be checked at the compressor terminals to determine if there is proper voltage to the compressor. The voltage should not exceed the 10% above or below the rated compressor voltage.

EXAMPLE: If the voltage reads 115 volts with no load and it drops below 103 volts when the compressor starts, it may indicate that the supply wiring is too small or that the wire run is too long.

G. Listen for any unusual noise such as lines vibrating, etc. Correct the problem by tightening screws, slightly bending tubing, etc.

H. The temperature control thermostat which is located in the rear post is factory set for average conditions. A customer adjustment requires a coin or screwdriver to turn the slotted shaft. A numbered dial makes it easy to keep track of adjustments. #1 is warmest setting and #7 is coldest setting. An "OFF" position is provided for your convenience in defrosting the cabinet.

I. Allow the cabinet to pull down and cycle prior to loading with product (Approx. 24 hours).

GROUNDING INSTRUCTIONS

This appliance is equipped with a three-prong (grounding) plug for your protection against shock hazards. The appliance should be plugged directly into a properly grounded three-prong receptacle.

Where a two-prong wall receptacle is encountered, it must be replaced with a properly grounded three-prong receptacle in accordance with the National Electrical Code and local codes and ordinances. The work must be done by a licensed electrician.

IMPORTANT

Do not, under any circumstance, cut or remove the round grounding plug from the appliance plug.

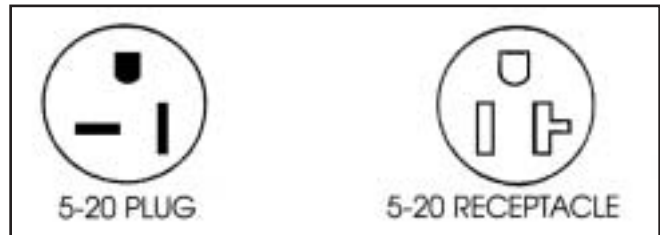

WARNING

Consult a licensed electrician if you have any doubt about the grounding of your wall receptacle. Only a licensed electrician can determine the polarization of your wall receptacle. Only a properly installed three-pronged wall receptacle assures the proper polarization with the appliance plug.

IMPORTANT USAGE INSTRUCTIONS

Dipping Cabinet

The cabinet must be located in an area free from air drafts created by open doors, air conditioning ducts, and fans. The cabinet should not be located in the direct sunlight.

The rear grill must be clear of any obstructions so the intake and exhausting of air for the condensing unit can move freely.

Dipping cabinets are designed for use in an air conditioned store. This cabinet is designed for merchandising, not hardening of the product.

High humidity can cause fogging of the lid and front glass.

High temperatures, installation of warm product and heavy usage can cause the product to soften. This condition will be more noticeable at the top of the cans.

The corners of the cabinets are the coldest areas. These areas should be used for product that is more difficult to keep firm.

Frost and ice act as insulators. The need for defrosting will depend on usage and product firmness.

If the frost is scraped daily with a plastic scraper, intervals between complete defrosting may be extended.

Thermostat adjustments should be made one increment warmer or colder allowing 24 hours between adjustments to allow the product to stabilize.

SECTION II

Principles of Operation

blank

GENERAL INFORMATION - REFRIGERATION SYSTEMS

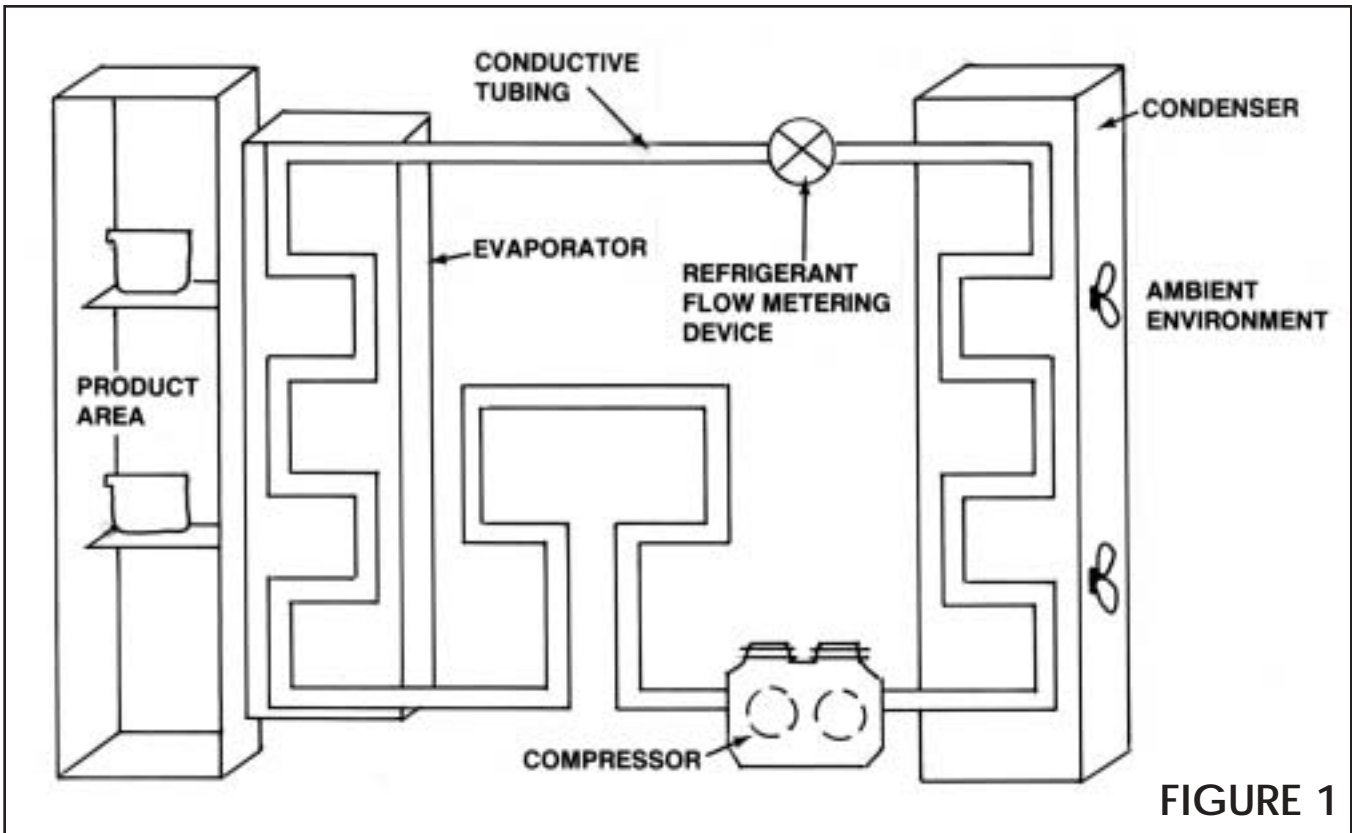

FIGURE 1

Basic refrigeration is based upon the Second Law of Thermodynamics ... "Heat will always flow from a warm object to and be absorbed by an object of substance of colder temperature."

The purpose of a mechanical refrigeration system is to provide for efficient and continuous cooling.

In order for this to take place, the system must provide a means to transfer heat from the products being refrigerated to an area that will not affect the product (See Figure 1).

This is accomplished through the circulation of refrigerant contained in conductive tubing, past the area where the products are stored.

The refrigerant absorbs the heat from the product area and transports it to where the heat can be dissipated into the air outside the cabinet. Four essential components are needed in a simple refrigeration system:

- An Evaporator
- A Compressor
- A Condenser
- and a Refrigerant Flow Metering Device

The purpose of the evaporator is to draw the heat from the product or storage area. As low temperature, low pressure liquid refrigerant enters the evaporator, it begins to boil or vaporize as it absorbs the heat of the product and cabinet interior.

The vaporized refrigerant is drawn through the evaporator by the compressor, in addition to causing the necessary flow of refrigerant within the circuit.

The compressor also increases the pressure of the vaporized refrigerant flowing from the compressor to the condenser.

The increased pressure causes the temperature of the refrigerant to rise above the ambient temperature of the room.

This condition allows the heat in this vaporized high pressure refrigerant to be released into the room's ambient environment.

As heat is released, the vaporized refrigerant returns to a liquid state.

If there is a large amount of heat to be released, this heat transfer is increased by using a fan to ensure a constant flow of cooler ambient air through the condenser coil.

The cooled liquid refrigerant leaves the condenser under high pressure and travels to the refrigerant flow metering device.

This device regulates the flow of refrigerant into the evaporator.

By restricting this flow, the liquid refrigerant moves to the evaporator under low pressure. (See FIGURE 1)

This lower pressure is necessary for the refrigerant to have the capability to vaporize and absorb heat.

The cycle will continue until the desired temperature within the product area is reached.

At this point, the compressor shuts off and the refrigerant cycle is interrupted until further cooling is required.

This simple refrigeration system is known as a single stage system. It is the most common refrigeration system and is used for applications where the product area temperatures do not exceed -20° Fahrenheit.

The single stage system is used on product dipping cabinets.

Product dipping cabinets utilize a cold wall evaporator. (See FIGURE 2).

Here the refrigerant lines actually contact the product area's inner wall. Heat is transferred through the wall and into the refrigerant.

To understand how the refrigerant system creates cold temperatures, it is important to understand how the temperatures of the area into which the heat will be dissipated affect the system's performance.

Simply stated, a refrigerant system's ability to cool a product area is dependent upon the unit's ambient environment.

For example, a single stage system dissipating heat through its condenser into a 60°F ambient environment is capable of cooling a cabinet's interior to a lower temperature than an identical system operating in an 80°F ambient environment.

To understand the complete heat transfer and extraction process in systems, let's discuss the function of the major system components.

There are three components in each system used for transferring heat. They are the Evaporator, the Compressor, and the Condenser.

Heat is transferred through the refrigerant lines by the compressor. This heated refrigerant arrives at the condenser for dissipation.

The heat transfers to the evaporator because it is colder.

The heat then moves through the compressor and leaves the cabinet at the condenser, where it transfers or dissipates into the cooler room air.

This heat transfer continues until the system has absorbed all the heat it is capable of removing, and has pulled down to the coldest temperature possible, or it has reached its thermostatic set point and shuts off.

On product dipping cabinets, the copper evaporator lines are strapped to the inner tank walls to form a cold wall evaporator.

This is foamed into place with two inches of urethane insulation to form a rigid bond between the outer shell and inner liner, which is another metal barrier used for strength and insulation separation.

The direction of the refrigerant flow is from the top to the bottom.

The cold wall evaporator is not serviceable within the walls of the cabinet because of the foam construction.

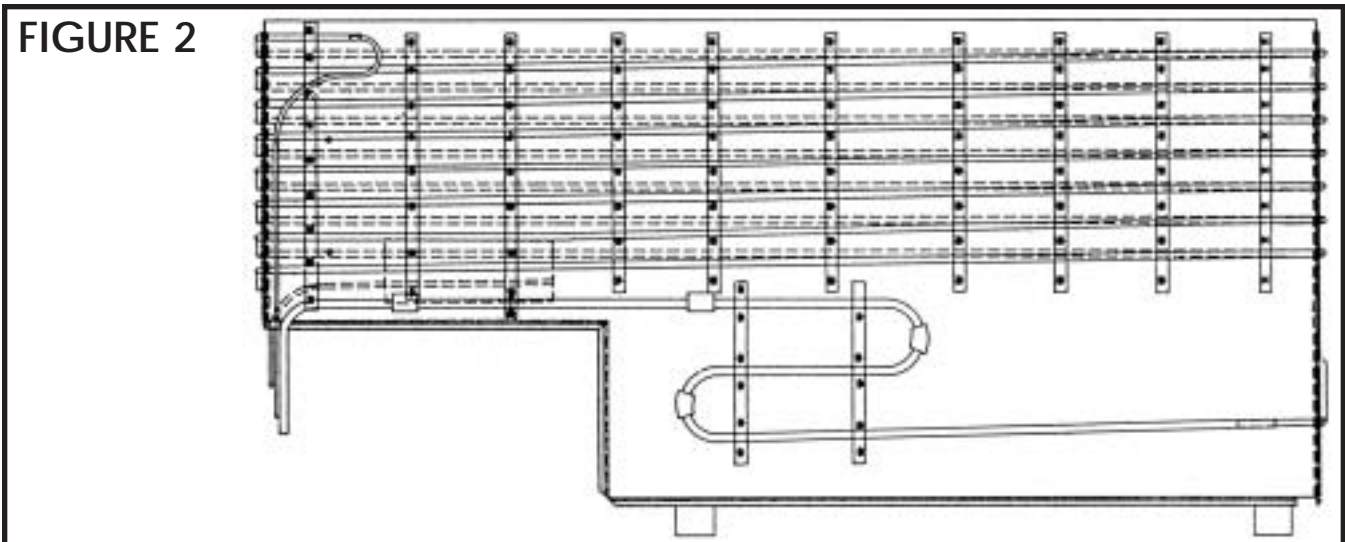

FIGURE 2

SYSTEM INFORMATION - BRT-68

ELECTRICAL

Compressor	Manufacturer: Americold Model: HP-127-1 Ph.: 1 Hz.: 60 Volts: 115 Amps: 4.2
Overload Protector	Manufacturer: Americold
Start Relay	Manufacturer: Americold
Start Capacitor	V.: 125 M.F.: 189-227
Run Capacitor	VAC: 370 M.F.: 20

Evaporator	Cold Wall
Capillary Tube	7' of .042

Thermostat	Manufacturer: Ranco F.L.A.: 25 V.: 120/250 L.R.A.: 100	
Warm Cut-in	11°	Warm Cut-out —
Mid Cut-in	-12°	Mid Cut-out -24°
Cold Cut-in	—	Cold Cut-out -34°

Condenser	Manufacturer: Heatcraft
Condenser Fan Motor	Manufacturer: G.E. Model: 5KSM51GG3784
Condenser Fan Blade	Diameter: 9.5" # Blades: 3 Width of Blades: 1 29/32"

Power Cord	A.W.G.: 16 A.: 15 V.: 125
Light Ballast	Manufacturer: G.E. Model: 89G457
Fluorescent Lamp	Manufacturer: G.E. F40T12CW

REFRIGERATION - Refrig. Charge: R-404A / 25 oz. / 708.75 grams / No. 4 Stat Position

AMBIENT TEMPERATURE	70°F / 21.1°C	80°F / 27°C	90°F / 32.5°C
Suction Pressure - C.O. PSIG/Kpa	9 / 62	10 / 69	11 / 76
Discharge Pressure - C.O. PSIG/Kpa	198 / 1365	230 / 1586	268 / 1848
Compressor Amps	4.2	4.2	4.3
Total Cabinet Amps	6.1	6.1	6.2
Cavity Temperature	0°F / -17°C	1°F / -17°C	2°F / -16°C

SYSTEM INFORMATION - BRT-90

ELECTRICAL

Compressor	Manufacturer: Americold Model: HP-127-1 Volts: 115 Amps: 4.2 L.R.A.: — Ph.: 1 Hz.: 60
Overload Protector	Americold #1456-3321
Start Relay	Americold #1456-3374
Start Capacitor	V.: 125 M.F.: 189-227
Run Capacitor	V: 370 M.F.: 20

Evaporator	Cold Wall
Capillary Tube	7' of .042

Thermostat	Manufacturer: Ranco F.L.A.: 25 V.: 120/240 L.R.A.: 100	
Warm Cut-in	11°	Warm Cut-out —
Mid Cut-in	-12°	Mid Cut-out -24°
Cold Cut-in	—	Cold Cut-out -34°

Condenser	Manufacturer: Heatcraft
Condenser Fan Motor	Manufacturer: G.E. Model: 5KSM51GG3784
Condenser Fan Blade	Diameter: 9.5" # Blades: 3 Width of Blades: 1 29/32"

Power Cord	A.W.G.: 16 A.: 15 V.: 125
Light Ballast	Manufacturer: G.E. Model: 8G3706
Fluorescent Lamp	Manufacturer: G.E. F40T12CW

REFRIGERATION - Refrig. Charge: R-404A / 27 oz. / 765.45 grams / No. 4 Stat Position

AMBIENT TEMPERATURE CONTROL SETTINGS	70°F / 21.1°C #4 C.S.	80°F / 27°C #4 C.S.	90°F / 32.5°C #4 C.S.
Suction Pressure - C.O. PSIG/Kpa	9 / 62	10 / 69	12 / 82
Discharge Pressure - C.O. PSIG/Kpa	207 / 1427	234 / 1613	262 / 1806
Compressor Amps	3.8	3.8	3.9
Total Cabinet Amps	6.3	6.3	6.3
Cavity Temperature	-0.5°F / -18°C	-0.3°F / -17.9°C	-1.2°F / -18.4°C

SYSTEM INFORMATION - EBRT-68 (220V / 50 Hz) ELECTRICAL KBRT-68 (220V / 60 Hz)

Compressor	Mfg: Copeland (3/4 HP) Model: KAMB-007E-CAV Phase: 1 Hz.:50
Overload Protector	Model No.: 071-0092-29
Start Relay	G.E. 3ARR3CT3E5 Pick up: 340-360 Drop out: 45-115 Model No.: 040-0001-03
Start Capacitor	V: 220 M.F.: 145-174

Evaporator	Cold Wall
Capillary Tube	9' of .042

Thermostat	Manufacturer: Ranco F.L.A.: 25 V.: 125/250 L.R.A.: 100	
Warm Cut-in	11°	Warm Cut-out —
Mid Cut-in	-12°	Mid Cut-out -24°
Cold Cut-in	—	Cold Cut-out -34°

Condenser	Manufacturer: Heatcraft
Condenser Fan Motor	Manufacturer: G.E. Model: KSM51GG3705
Condenser Fan Blade	Diameter: 9½" # Blades: 3 Width of Blades: 1 ²⁹ / ₃₂ "
High Pressure Switch	Ranco Preset 400 PSIG Diff 100 PSIG

Power Cord	A.W.G.: 16 Amp: 15
Light Ballast	Mfg: Vossloh Schwabe Model: L36.291 (50 Hz) Robertson: 1-4026 (60 Hz)
Fluorescent Lamp	Manufacturer: G.E. F40T12CW

REFRIGERATION - Refrig. Charge: R-404A / 25 oz. / 708.75 grams / No. 4 Stat Position

AMBIENT TEMPERATURE	70°F / 21.1°C	80°F / 27°C	90°F / 32.5°C
CAVITY TEMPERATURE	2°F / -17°C	4°F / -16°C	6°F / -14°C
Suction Pressure - C.O. PSIG/Kpa	8 / 55	10 / 69	12 / 82
Discharge Pressure - C.O. PSIG/Kpa	188 / 1296	225 / 1551	253 / 1744
Compressor Amps	7.2	7.1	7.1
Total Cabinet Amps	9.5	9.3	9.4

SYSTEM INFORMATION - EBRT-90 (220V / 50 Hz) ELECTRICAL KBRT-90 (220V / 60 Hz)

Compressor	Mfg: Copeland (3/4 HP) Model: KAMB-007E-CAV Phase: 1 Hz.:50
Overload Protector	Copeland Model No.: 071-0092-20
Start Relay	G.E. 3ARR3CT3E5
Start Capacitor	V: 220 M.F.: 145-174
Run Capacitor	V: 370 M.F.: 10

Evaporator	Cold Wall
Capillary Tube	9' of .049

Thermostat	Manufacturer: Ranco Model No.: 9540N46 F.L.A.: 25 V.: 125/250 L.R.A.: 100	
Warm Cut-in	11°	Warm Cut-out —
Mid Cut-in	-12°	Mid Cut-out -24°
Cold Cut-in	—	Cold Cut-out -34°

Condenser	Manufacturer: Heatcraft
Condenser Fan Motor	Manufacturer: G.E. Model: KSM51GG370E 115V / 60 Hz. / Ph. 1
Condenser Fan Blade	Diameter: 9½" # Blades: 3 Width of Blades: 1 ²⁹ / ₃₂ "
High Pressure Switch	Ranco Preset 400 PSIG Diff 100 PSIG

Power Cord	A.W.G.: 16 V.: 220 Amp: 15
Light Ballast	Mfg: Vossloh Schwabe Model: L36.291 (50 Hz) Robertson: 1-4025 (60 Hz)
Fluorescent Lamp	Manufacturer: G.E. F40T12CW

REFRIGERATION - Refrig. Charge: R-404A / 27 oz. / 765.45 grams / No. 4 Stat Position

AMBIENT TEMPERATURE	70°F / 21.1°C	80°F / 27°C	90°F / 32.5°C
CAVITY TEMPERATURE	2°F / -17°C	4°F / -16°C	7°F / -14°C
Suction Pressure - C.O. PSIG/Kpa	8 / 55	10 / 69	12 / 82
Discharge Pressure - C.O. PSIG/Kpa	228 / 1572	257 / 1772	284 / 1958
Compressor Amps	7.4	7.5	8
Total Cabinet Amps	9.5	9.3	10

WIRING DIAGRAM - BRT-68 & BRT-90

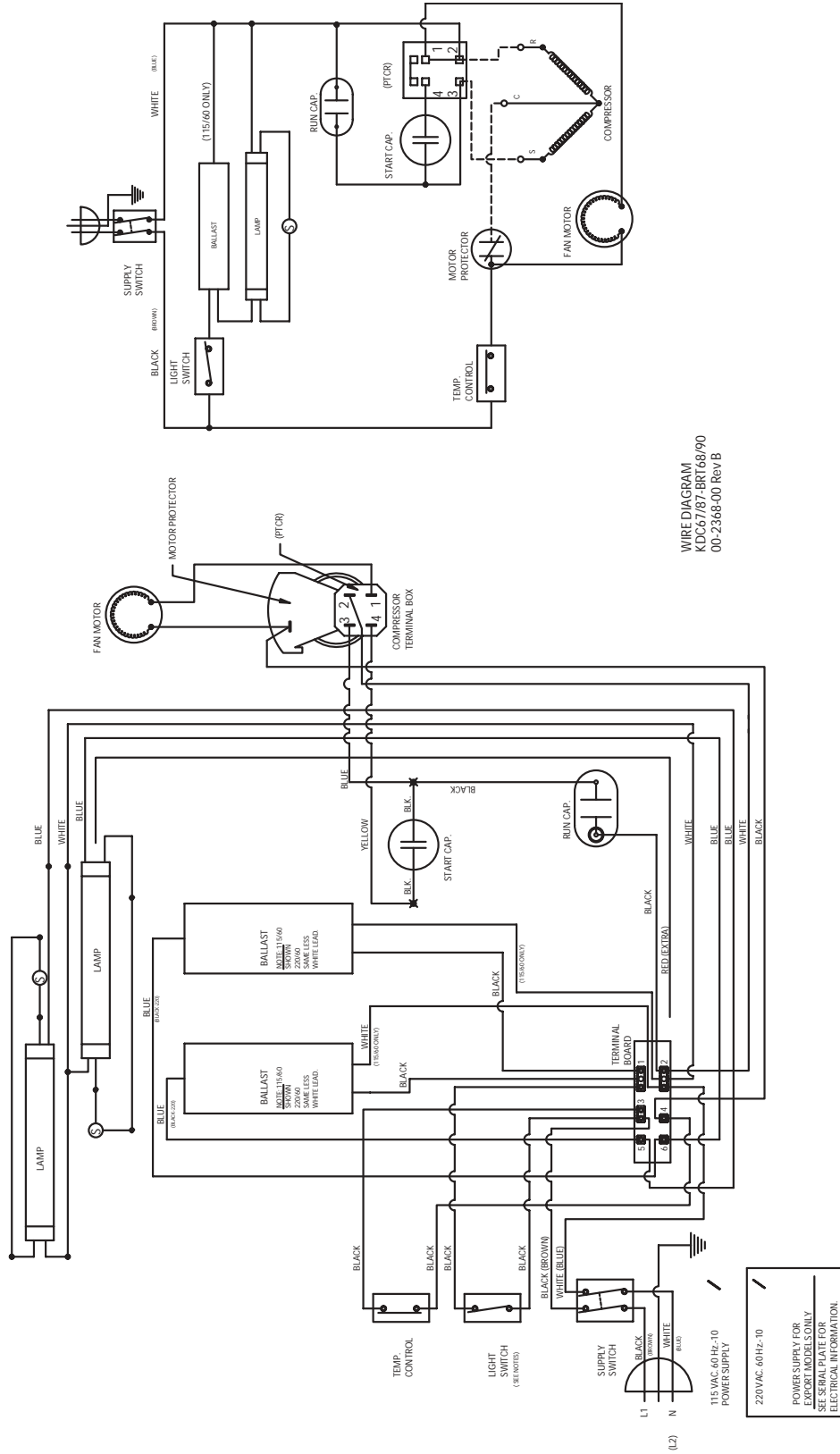

WIRE DIAGRAM
KDC67/87-BRT68/90
00-2368-00 Rev B

WIRING DIAGRAM - EBRT-68 / EBRT-90 KBRT-68 / KBRT-90

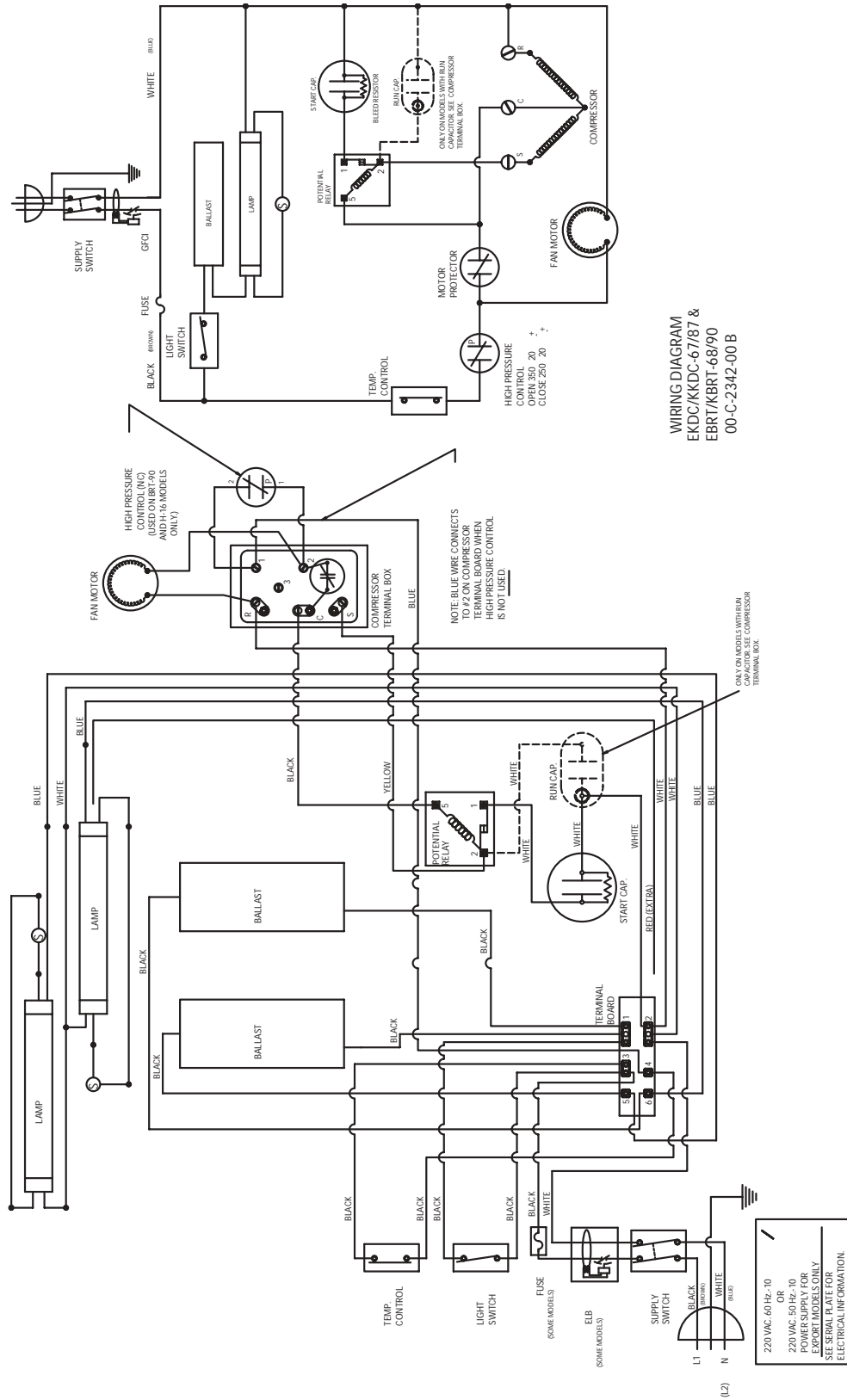

SECTION III

Maintenance & Repair

WARNING:

To avoid the possibility of an electrical shock, turn OFF thermostat and unplug the power cord of the cabinet before cleaning or touching electrical connections or parts.

PRE-SERVICE CHECK LIST

You may avoid the cost and inconvenience of an unnecessary service call by first reviewing this check list of the most frequently encountered situations that are not the result of system component failure.

COMPRESSOR RUNS TOO MUCH

1. A refrigerated cabinet automatically compensates for service loading by running longer and more often. Before calling for service, check running time for at least one hour the first thing in the morning (before store traffic starts).
2. Be sure doors seal. A faulty gasket seal will cause increased running time.
3. Check the room temperature. The warmer the room, the more the compressor will run.
4. Check the condenser to be sure the face is clean. Dirt and lint will raise the pressures and increase running time. Use a brush or vacuum to clean the condenser.
5. Check to see that condenser fans are running.
6. If product is too hard, (cold) try setting the temperature control (thermostat) warmer. This will result in warmer cabinet temperature and reduced running time.

CABINET DOES NOT OPERATE

1. Be sure the cabinet is plugged in.
2. Check that the breakers or fuses are good and all switches in the supply line are ON.
3. Be sure that cabinet Master Supply Switch is ON.
4. If you are in an area with voltage problems, try shutting off all non-essential electric equipment.

LIGHT IS OFF

1. If the cabinet is operating, be sure the lamp is properly seated in sockets.
2. If the cabinet is not running, check that Master Supply Switch of cabinet is ON, fuses are okay, no switch in the supply is off and the cabinet is plugged in.

CUSTOMER COMPLAINT OR STORED PRODUCT

1. Check cleaning solutions used inside cabinet.
2. Check cleaning solutions, paint or other contaminants used in store maintenance.
3. Sometimes the ingredients used in some products or containers will contaminate other products.
4. Be sure to follow a weekly schedule for cleaning cabinet interior.

SERVICE

In the event of a malfunction, damage to the cabinet, or if the cabinet requires service beyond the items in the "Pre-Service Check List," contact your local refrigeration service company or the dealer or distributor you purchased the unit from.

POWER FAILURE

Do not open the cabinet doors unnecessarily if power is cut off due to electrical failure. The cabinet will start up if the power supply returns, but will require sufficient time to reach maximum cold storage performance.

CABINET FAILURE

1. If the cabinet has stopped operating, check that the cabinet is securely plugged in and turned on. Contact a licensed electrician to locate and correct any power supply problems.
2. Do not open the cabinet lids unnecessarily.
3. Provisions for other storage of the product may be required to prevent spoilage.

If you call us for service, describe the problem and give the information from the following list to the service representative:

Cabinet Model _____

Part Number _____

Serial Number _____

(These are located on a serial number rating plate inside of the machinery compartment of the cabinet.)

SECTION III

MAINTENANCE & REPAIR

TOOLS:

To provide full service diagnostics and repairs on these cabinets the following tools are needed:

A Volt Meter

An Amp Meter

An Ohm Meter or triplet meter to handle all three functions

An Electronic Leak Detector

An Electronic Micron Gauge

A Vacuum Pump capable of pulling to 50 microns

Four Hand Valves

A Refrigerant Reclaimer

A Compound Gauge Set

A cylinder of nitrogen with a regulator capable of 10 to 400 pounds.

Standard refrigeration hand tools like: wrenches, tubing cutter, swage and flare tools, wire strippers, wire crimpers, wire cutters, standard and phillips head screwdrivers.

PRODUCT HISTORY

The first rule in accurately servicing a refrigeration system is to determine if the problem is an electrical or mechanical failure within the refrigeration system.

First, try to obtain the product's history of operation from the customer. This will help identify the source of the problem.

Good facts from the cabinet user can help identify whether the problem is electrical, within the refrigeration system, or a "misapplication by the user." Get the history of operation and failure by asking these questions:

- 1) Were there any brown-outs or power outages that they are aware of?
- 2) Is the cabinet on a dedicated circuit?
- 3) Has any other equipment in this area had operational problems?
- 4) When was the last time the cabinet's operation was confirmed as working properly?
- 5) When was a problem noticed?
- 6) How long has the equipment run without this problem? (Years? Weeks? Days? Hours?)

7) Was anything tried prior to your arrival?

8) Was the warm-up fast, as in three to six hours, or over a prolonged time, as in three to five days?

9) If the cabinet was running for a long time, was the temperature recovery after entering the cabinet always within an hour, or did it appear as though recovery time was longer as usage went on?

The refrigeration system should only be entered if it is absolutely necessary. It is critical that a clean, uncontaminated system be maintained.

If a system is unable to reach the proper operating temperature, a test of the unit's mechanical refrigeration components is required.

COMPRESSOR EFFICIENCY TEST

If the cabinet has a semi-hermetic compressor, begin by testing the compressor's efficiency.

To test a semi-hermetic compressor, place compound gauge on the compressor's suction port.

While the compressor is running, close off the suction line so that only the port and valve are part of the compressor's low side.

When the valve is closed and vacuum has started, time how long it takes to pull the compressor's low side to its lowest possible vacuum.

Compressors used on these cabinets should be capable of pulling at least 20 to 22 inches of vacuum in less than 40 seconds.

Next, shut off the compressor and watch the gauge. A one or two inch rise in pressure is acceptable, since a small amount of freon may remain on the low side of the compressor, after which the reading should stabilize.

If the pressure continues to rise, the discharge reeds in the valve head are bad, allowing high pressure gas to return to the compressor.

If the compressor pulls less than 20 inches, the suction reeds are bad in the valve head.

If it takes longer than 40 seconds to pull the compressor, to its ultimate low vacuum, one or both cylinders are not functioning as they should. Any reading less than these will require replacement of the compressor.

ENTERING THE SYSTEM

Entering the system should only be done as a last resort. Extreme care must be used no matter what the reason is for entering the system. Of course there are times it cannot be avoided, such as component or compressor replacement, or a leak within the system.

The system must also be entered any time you need to obtain the operating pressures. Again, use extreme caution to avoid any possible contamination.

Cabinets that use semi-hermetic compressors allow easy access through the valve ports.

Cabinets using hermetic compressors do not have valve ports, this product has process stubs for both suction and discharge sides of the system.

Line taps should only be used to obtain pressure readings, and not for reprocessing a system. The opening of a line tap is too restrictive for pressure of vacuum procedures.

Install hand valves at the process stub ends. Hand valves will be less restrictive to flow because of a larger opening. They will also be easier to use during repair procedures.

EVACUATION

Once the system has been cleaned and components have been replaced, you are ready to initiate the final servicing procedures necessary to achieve proper cabinet operation.

Pull an evacuation to approximately 50 microns. You can be sure that any contaminants that can affect the system's operation are now removed.

Use this time to check any joints for potential leaks.

CHARGING

You should use a charging cylinder to measure in the the correct amount of refrigerant. The charging methods are:

- 1) Add the refrigerant to the system until you reach a predetermined balanced pressure. This will give you an approximate static charge.
- 2) Weigh in the refrigerant using a scale calibrated in ounces.

The cabinet's operation is now ready to be tested. A final check of the refrigeration lines should be made before running the cabinet.

Be sure the refrigeration lines are not kinked or rubbing against each other.

Also check that the door seals properly. An air leak will affect proper operation, and the cabinet's ability to reach its coldest temperature.

Run the cabinet a both 100% run and also at a cycling temperature for at least one day. If the temperature and pressures are correct, the system can be considered repaired.

Hermetic systems should now have their process stubs pinched off, hand valves removed and the ends brazed shut.

COMPRESSOR INSTALLATION & MAINTENANCE / DIAGNOSTICS

HOLD DOWN BOLTS

All models with Copeland compressors have hold down bolts. The compressor has a metal hold down band strapping it tightly to the cabinet body. This band should be removed and discarded upon installation. If compressor does not float freely, keep backing off all of the retaining nuts until it does.

CHECKING COMPRESSOR THAT WON'T START ON CORD CONNECTED CABINETS

1. Check that the supply plug is in wall outlet and that outlet has the proper voltage.
2. Check that the cabinet thermostat is on a numerical setting.

If items 1 & 2 are OK:

3. Pull condensing unit out of the cabinet and remove compressor terminal cover. Check proper voltage at terminals.

TO CHANGE THE COMPRESSOR:

1. Disconnect the power supply to the cabinet.
2. Disconnect power supply leads at the compressor.
3. Disconnect the wires to the relay and capacitors.
4. Remove the relay and starting capacitor and install on the new compressor.
5. Remove the defective compressor from the condensing unit base.
6. Set the new compressor in place.
7. Reconnect the relay and capacitor wires.
8. Reconnect the power supply lead.
9. Leak test, evacuate, and weigh in charge.

TO CHANGE THE DRIER

If flare connected, make sure flares and faces of fittings on new drier are clean and in good condition before installing new drier.

Cut tubing only with tube cutters, not hacksaw's, to avoid metal filings from entering the system. Driers must be replaced any time you enter the system, except when you are obtaining operating pressures.

SERVICE VALVES

The compressors on some cabinets have service valves for measuring suction and discharge pressures. Two types are used. The first type is connected directly to the compressor body or shell and back seats to connect gauges to the access port. The second (Schrader type) is on the end of a process tube and requires a gauge or charging line with a depressing pin to open valve when the connection is made.

CAUTION

This type valve should be tightly capped except when making the gauge connection.

TO CHECK FOR OPEN WINDINGS

Use a multimeter. Measure ohms between "C" and "R" and between "C" and "S".

If windings are OK, multimeter will show a resistance reading between terminals.

If there is no reading, the compressor, winding or windings are open and the compressor should be replaced.

TO CHECK FOR GROUNDED COMPRESSOR

Use multimeter. Touch probe from each terminal to an unpainted surface of compressor body. If there is no ground, there will be no change of the meter.

WARNING: Be Careful Not to Touch Uninsulated Parts of the Meter Probes.

A reading indicates a ground and the compressor should be replaced.

If there is voltage at the compressor terminals and the compressor tries, but does not run, check voltage at the compressor terminals while attempting to start the compressor. If the voltage at the compressor terminal is below 90% of the nameplate voltage, it is possible the motor may not have developed sufficient torque to start. Check to determine if:

- A. Wire sizes are adequate.
- B. Electrical connections are loose.
- C. The circuit is overloaded.
- D. The power supply is adequate.

A defective relay or capacitor may prevent the compressor starting.

TO CHECK OUT THE RELAY

1. Disconnect the cabinet from the power supply.
2. Remove the wires from the relay.
3. Touch probes to the terminals. Meter should show infinity if closed.
4. Touch probes to the terminals of coil. The meter should show a resistance reading.

If items 3 & 4 are OK, the relay is good. If items 3 & 4 are not as indicated, change the relay.

COMPRESSOR INSTALLATION & MAINTENANCE / DIAGNOSTICS

TO CHECK CAPACITORS

1. Disconnect the cabinet from the power supply.
2. Make sure the capacitors are discharged before checking. (Shunt across the terminal of capacitor with a heavy insulated wire.)
3. Remove the wires from the capacitors.
4. Any capacitor found to be bulging, leading, or damaged should be replaced.
5. Use a multimeter to check the **run and start** capacitors for shorts or open circuits.
 - A. Set ohmmeter to X1000 scale.
 - B. Standardize equipment
 - C. Touch probes to capacitor terminals.
 1. With a good capacitor, the indicator should first move to zero and then gradually increase to infinity.
 2. If there is no movement of the ohmmeter, an open circuit is indicated.
 3. If the ohmmeter indicator moves to zero, and remains there or on a low resistance reading, a short circuit is indicated.

On run capacitor, touch probes to metal case and each terminal. If meter shows any deflection, a ground is indicated. All defective capacitors should be replaced.

CLEANING & MAINTENANCE

CLEANING THE CABINET EXTERIOR

Wipe the exterior occasionally with a cloth dampened in mild detergent water; rinse, and wipe dry with a soft, dry cloth. **Do not use abrasive or caustic cleaners or scouring pads.**

CLEANING THE CONDENSER - FIG. 1A

Periodic cleaning of the condenser can be easily accomplished by brushing the coils with a soft brush and/or using a vacuum cleaner with a brush attachment.

Be sure that dirt, dust and collection of other debris do not build up to a point air circulation through the condenser is restricted.

CLEANING THE STORAGE COMPARTMENT

1. Remove product and store it in another suitable cabinet, if possible. Be sure to prevent spoilage of the product which may occur if it is left at room temperature.
2. Turn OFF the thermostat and unplug the cabinet.
3. Remove the can skirts.
4. Defrost completely prior to cleaning.
5. Wash the can skirts and the entire interior storage area with warm water and baking soda solution — about a tablespoon of baking soda per quart of water. Rinse thoroughly with clean water and wipe dry. This procedure can also be used for cleaning door gaskets.
6. A drain hose (FIG. 1B) is provided in the compressor compartment. Connection is made to fit a standard garden hose for ease of draining water from inside of the tank area.
7. Wash, rinse, and dry the can skirts while they are outside of the cabinet, using the same procedure as described for the storage area.
8. Be sure to correctly reinstall the can skirts, plug in the cabinet, set the temperature control and allow time for cooling of the storage area before storing product.

IMPORTANT: Do not use any objects or cleaner which may leave residues, odors, or particles. Avoid the use of strong chemicals or abrasive cleaners which may damage the interior surfaces and contaminate product within the storage area.

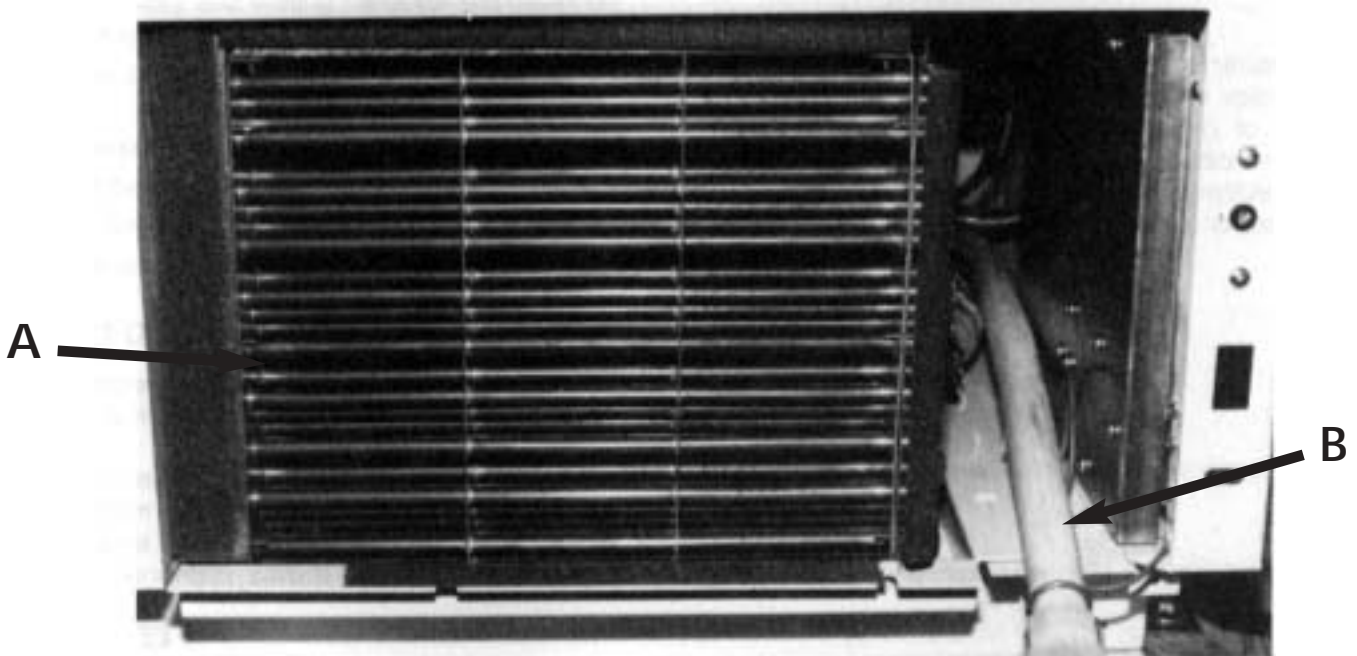

FIG. 1

WARNING :

To avoid the possibility of an electrical shock, turn OFF thermostat and unplug the electric cord of the cabinet before cleaning or touching electrical connections or parts.

CLEANING THE LID

If the lid has been removed from the cabinet, wash with plenty of non-abrasive soap or detergent and water. Use the bare hand to feel and dislodge any caked soil. Rinse thoroughly with clean water. Do not use hard, rough cloths that will scratch the surface of the plastic lid. Dry with a clean, damp chamois.

If the lid is on the cabinet where water cannot be used freely, it should first be lightly dusted (not wiped) with a

soft, clean cloth. Then the surface can be wiped carefully with a wet cloth or chamois. The cloth or chamois should be kept free of grit by frequent rinsing in clean water.

Do not use solvents such as acetone, alcohol, benzene, carbon tetrachloride, fire extinguisher fluid, dry-cleaning fluid, and lacquer thinners, since they attack the plastic part of the lid. **Do not** use window sprays or kitchen scouring compounds.

LID SEAL REPLACEMENT

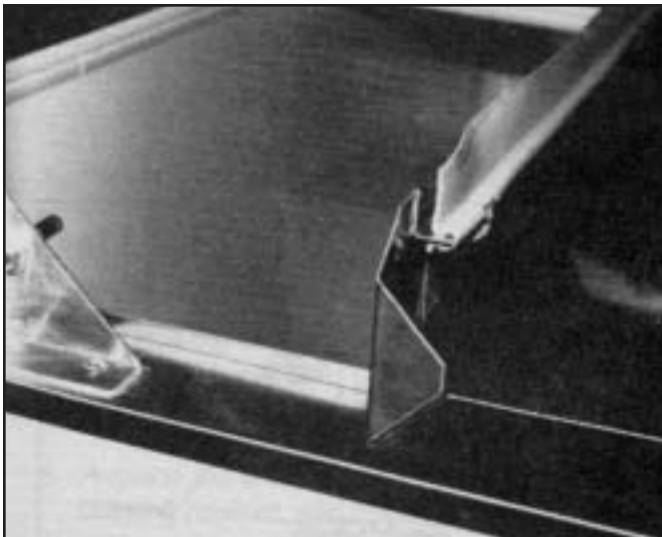
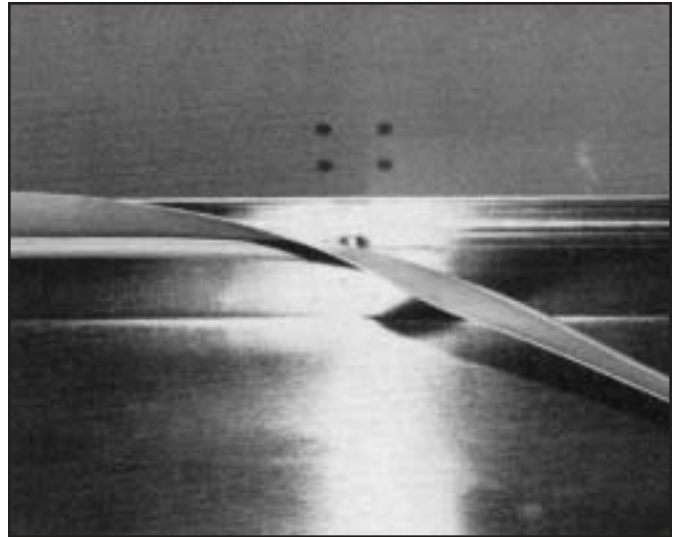

The lid seal is located on the server side of the cabinet, attached to the underside of the stainless steel top.

1. Remove lids from the cabinet.
2. Remove the stainless steel end trim located on each end of the cabinet. This will allow access to the screws that hold the stainless steel top in place.
3. Remove the six (6) screws on the underside of the stainless top on the server side of the cabinet.
4. Remove the stainless top from the cabinet.
5. Slide the lid seal off of the top channel.
6. Replace the lid seal with new correct part number. Seal needs to be cut to fit the cabinet width. Use double back tape or spray adhesive to hold the new seal in place.
7. Replace the stainless steel top with the lid seal attached.
8. Replace the six (6) screws under the stainless steel top server side.
9. Replace the four (4) screws located on each end of the canopy top.
10. Replace lids on the cabinet.

LID GASKET REPLACEMENT

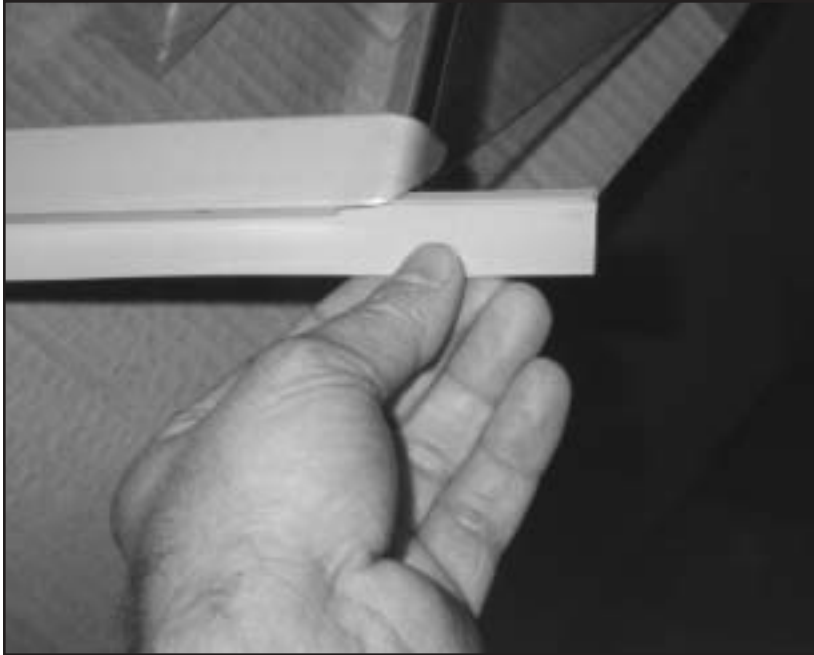

1. Remove the lid from the cabinet.
2. Set the lid on a flat, protected surface.
3. Rotate lid upside down.
4. Slide old gasket from the aluminum lid frame.
5. Install new gasket in the groove provided. See end detail.
6. Reinstall lid in cabinet.

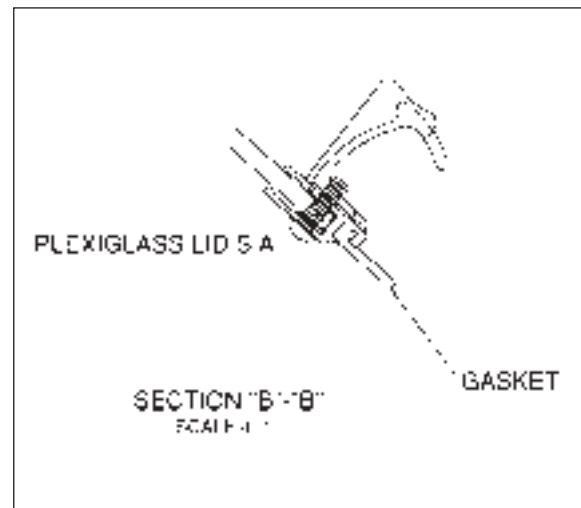

LID PIVOT BUSHING ASSEMBLY REPLACEMENT



Old Style

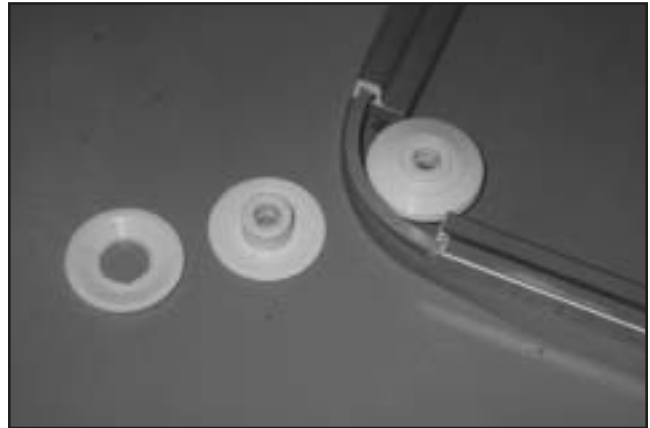

New Style

The pivot pin bushing is located on the outside edge of each lid.

1. Remove the lid from the cabinet. Lay the lid on a smooth, non-scratch surface.
2. Remove the two acorn nuts from the outside edge of the lid assembly.
3. Remove the shake-proof washer, flat washer, pivot bushing retainer, and pivot pin bushing.
4. Replace assembly with the correct new part number.
5. Replace the shake-proof washer, flat washer, pivot bushing retainer, and pivot pin bushing.
6. Replace the two acorn nuts attaching the assembly to the lid. Tighten nuts to 20" lbs. torque.
7. Replace the lid onto the cabinet.

Remove lid from cabinet. Lay the lid on a smooth, non-scratch surface. Simply unsnap lid pivot assembly and replace with a new part.

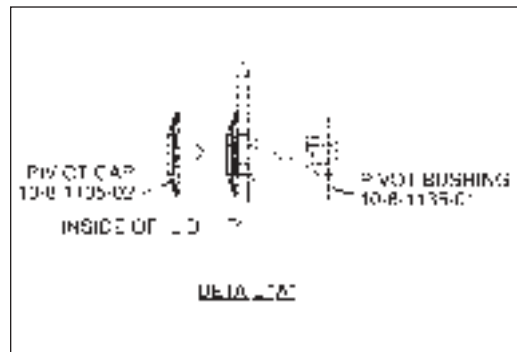

CENTER/END PIVOT ROD REPLACEMENT



Remove lids from the cabinet.
Remove 2 mounting screws from the mounting bracket.
Replace the pivot bracket with correct new part number.
Reinstall lid assembly.

The 4-hole and 8-hole dipping cabinets have end pivot pins only. The 12- and 16-hole dipping cabinets have end and center pivot brackets.

FLUORESCENT LAMP HOLDER & LIGHT STARTER SOCKET REPLACEMENT



FIG. 1

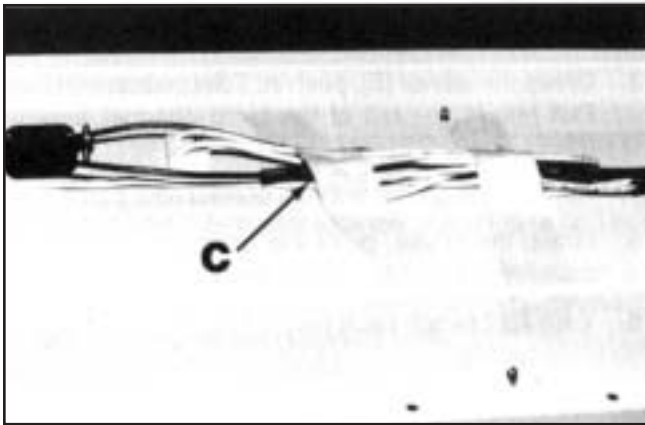

FIG. 2

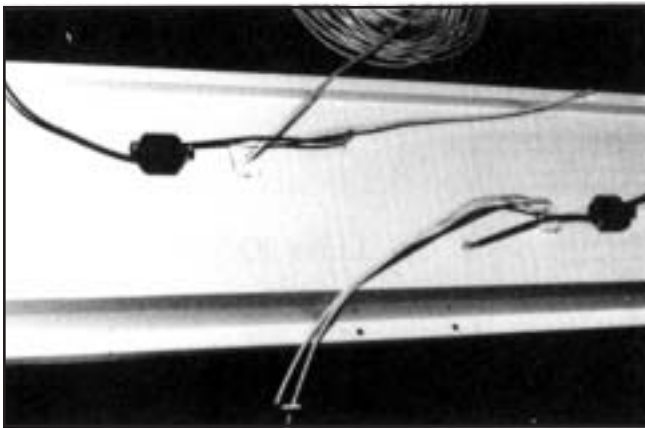

FIG. 3

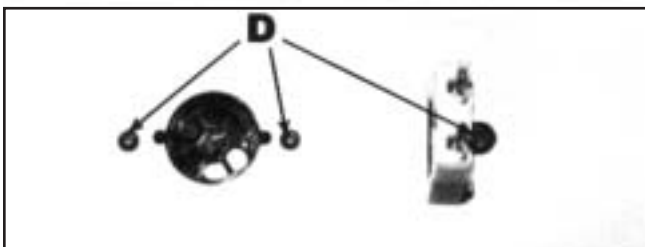
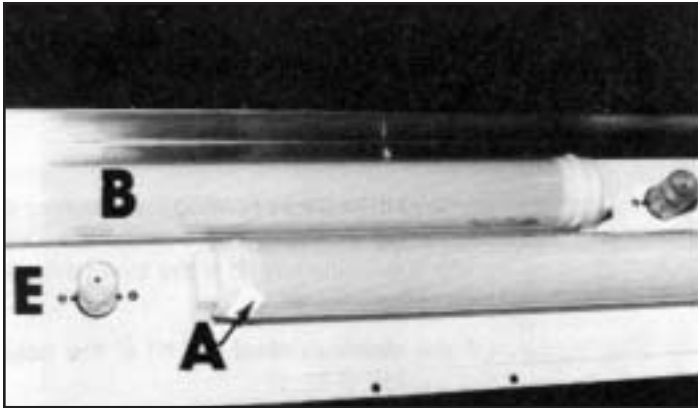

FIG. 4

The lamp holder and the light starter socket are located on the lamp channel assembly.

1. Disconnect the power to the cabinet.
2. Remove the lids from the cabinet.
3. Remove the fluorescent bulbs.
4. Remove the end trim located on each end of the cabinet. This will expose the screws that hold the top in place. Remove the four (4) screws on the top and the six (6) screws located underneath the stainless steel top (on the server side FIG. 1).
5. Lift the stainless steel top off of the cabinet. Set it aside.
6. For both the lamp holder and the starter socket, remove the screws holding the part in place. (FIG. 4-D) Remove the tape holding the wires to the channel frame. (FIG. 2)
7. Disconnect the lead wires at the butt splice connector. (FIG. 2-C)
8. Replace part with correct new part number.
9. Replace screws removed in Step 4. (FIG. 4-D)
10. Connect white and blue lead wires to main wire with butt connectors. Replace the tape holding the wires to the lamp channel.
11. Replace the stainless steel top (FIG. 1) using screws removed in Step 4.
12. Replace the starter.
13. Replace the bulbs (fluorescent).
14. Reconnect the power to the cabinet.

FLUORESCENT BULB & STARTER REPLACEMENT



BULB REPLACEMENT

1. Turn light switch off on the cabinet.
2. Pull down on the socket (A).
3. Remove the plastic outer lamp shield (B) and bulb (C).
4. Raise the bulb up. Pull out of the socket.
5. Remove lamp shields and end caps (D).
6. Place the new bulb in the shield. Attach end caps.
7. Insert the bulb into the cabinet, push up an snap into place.
8. Turn light switch back on.

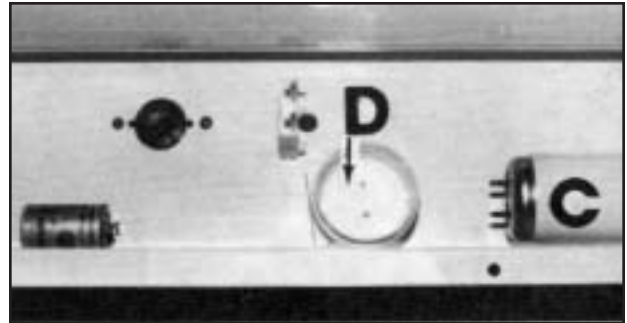

BULB STARTER REPLACEMENT

(The fluorescent bulb starter is located on the lamp channel assembly. One starter is necessary per bulb.)

1. Turn light switch off on the cabinet.
2. Remove the lid from the cabinet.
3. Grasp the starter (E), push in. Turn counterclockwise. Pull the starter out of the lamp channel assembly (F).
4. Replace the starter with the correct new part number.
5. Grasp the starter, push into contact holes. Turn the starter clockwise to seat properly.
6. Turn light switch back on.

THERMOSTAT REPLACEMENT

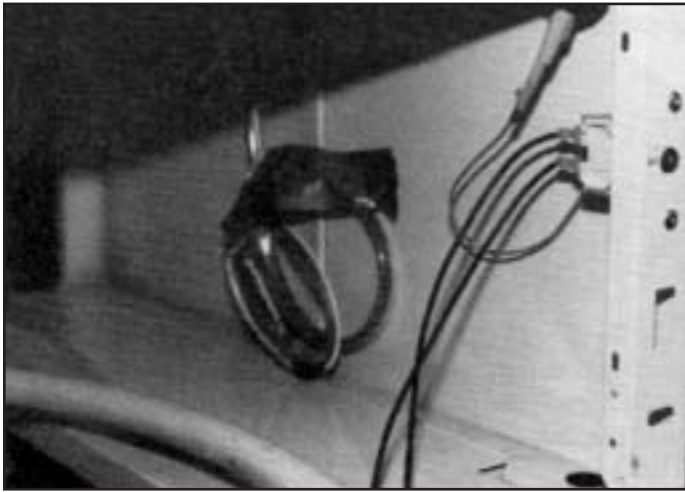

The thermostat is located on the server side of the cabinet, directly behind the service grill. It functions to control the temperature inside the cabinet. The range on the thermostat dial is adjustable from 1 to 7 (7 being the coldest setting). The OFF position is provided for defrosting the cabinet.

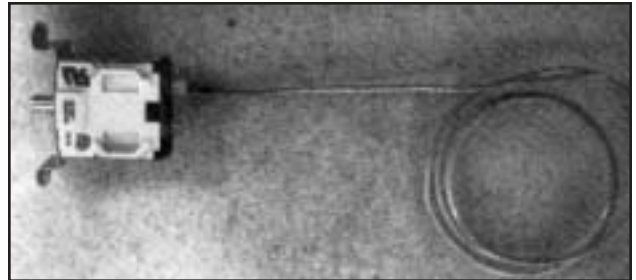

1. Disconnect the power to the cabinet.
2. Remove the grill.
3. Remove screws from the thermostat mount.
4. Pull the thermal bulb out of the cabinet.
5. Replace the thermostat with the correct new part number.
6. Slide the capillary tube up the control well which extends into the machinery compartment. (Be very careful. Do not kink the thermal bulb capillary tube.)
7. Reattach the thermostat screws to mounting holes.
8. Replace the grill assembly.
9. Reconnect the power to the cabinet.

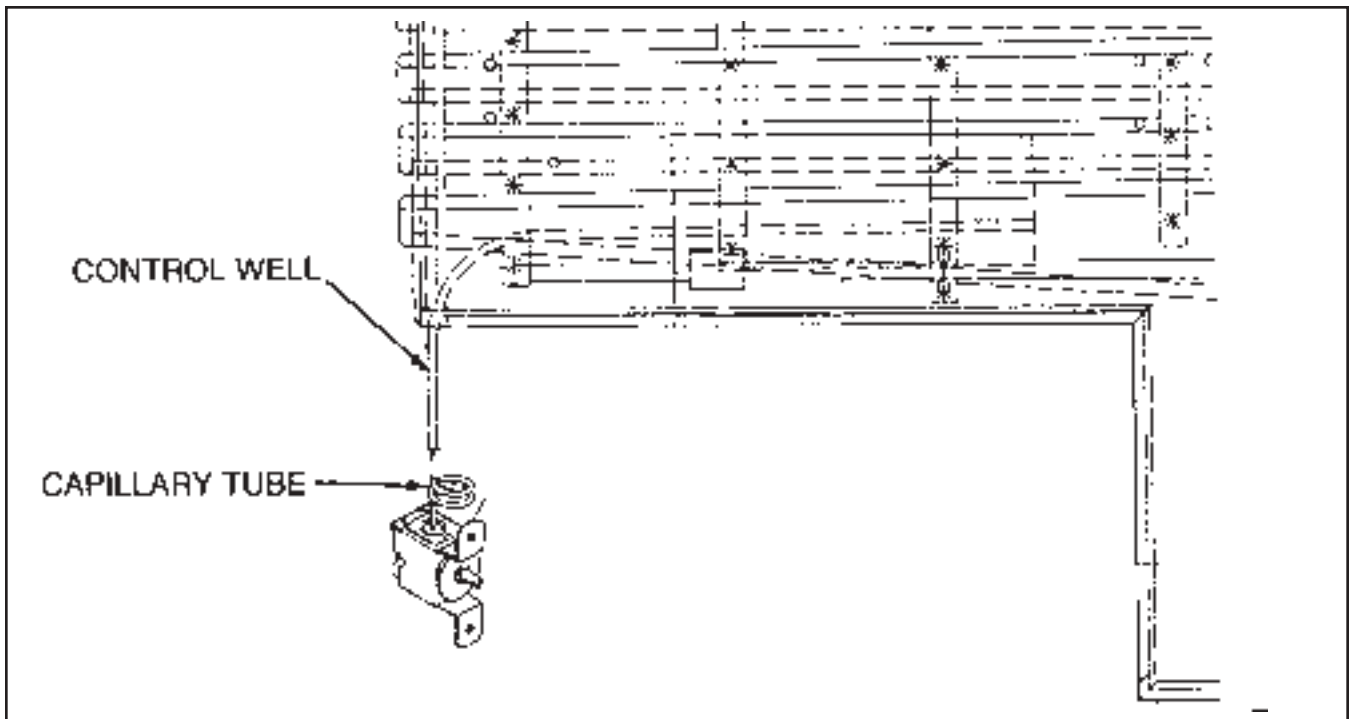

MASTER POWER SUPPLY SWITCH & LIGHT SWITCH REPLACEMENT

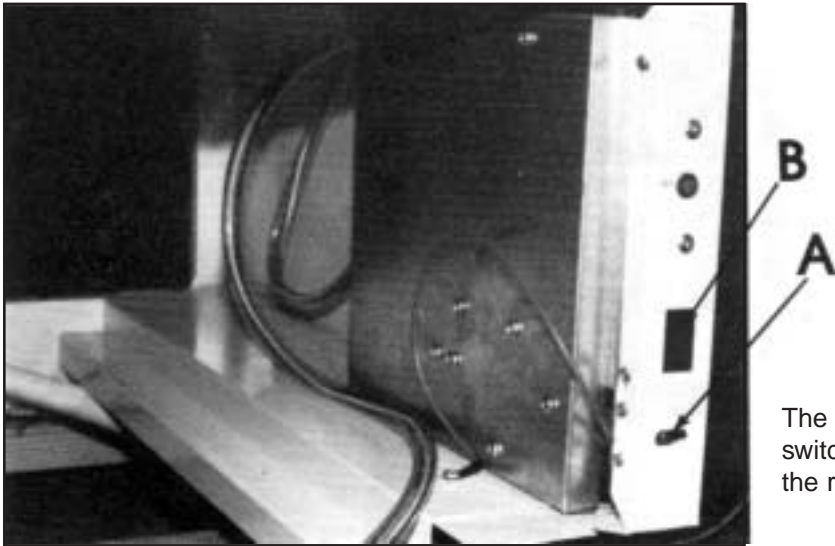

The master supply switch (A) and the light switch (B) are located behind the grill panel, on the righthand server side of the unit.

1. Disconnect the power to the cabinet.
2. Remove the grill.
3. Remove screws holding the switch in place.
4. Detach the switch leads.
5. Remove the lock nut on exterior of switch.
6. Replace with new switch.
7. Reattach the electrical leads.
8. Replace the front grill.
9. Reconnect the power to the cabinet.



CONDENSER FAN MOTOR REPLACEMENT

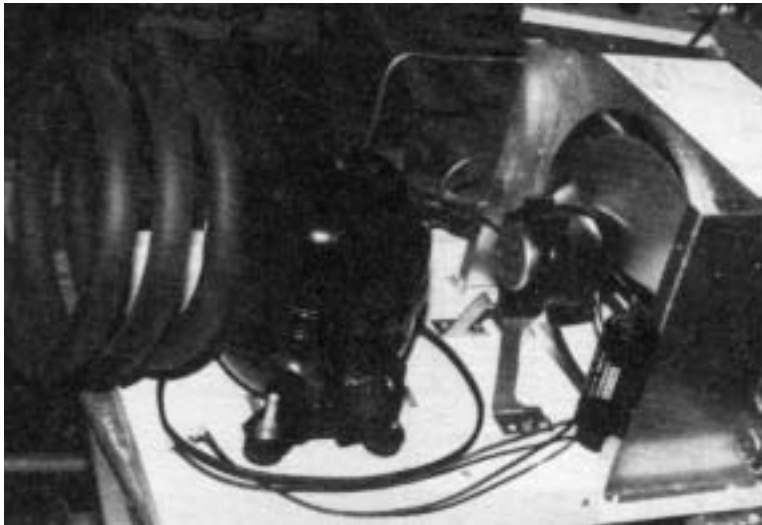

The condenser fan motor is located in the machinery compartment, directly behind the condenser coil.

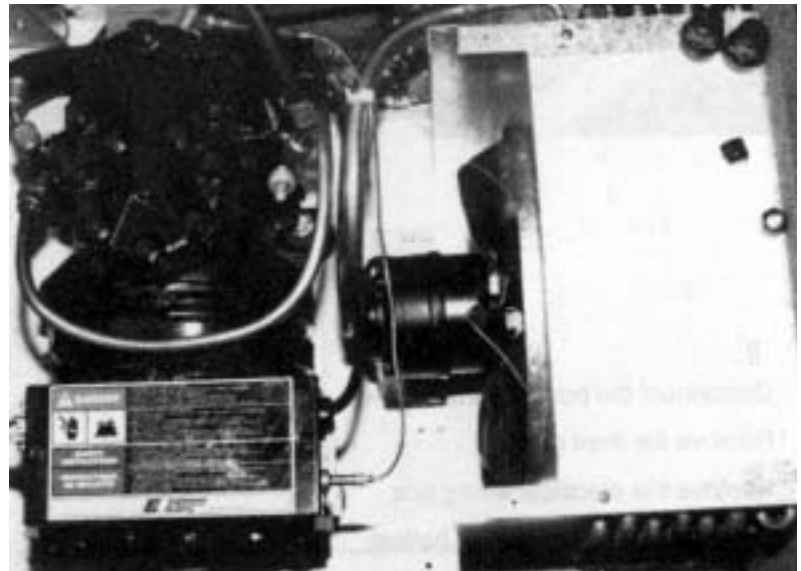

1. Disconnect the power to the cabinet.
2. Remove the grill panel.
3. Remove the condensing tray hold down bolts.
4. Pull the condenser tray out of the cabinet. Disconnect the wire at the compressor.
5. Remove the motor from the fan motor mounting bracket.
6. Replace with correct motor.
7. Reconnect wires at the compressor.
8. Slide the tray back into the cabinet. Replace hold down bolts.
9. Replace the front grill.
10. Reconnect the power to the cabinet.

BALLAST REPLACEMENT

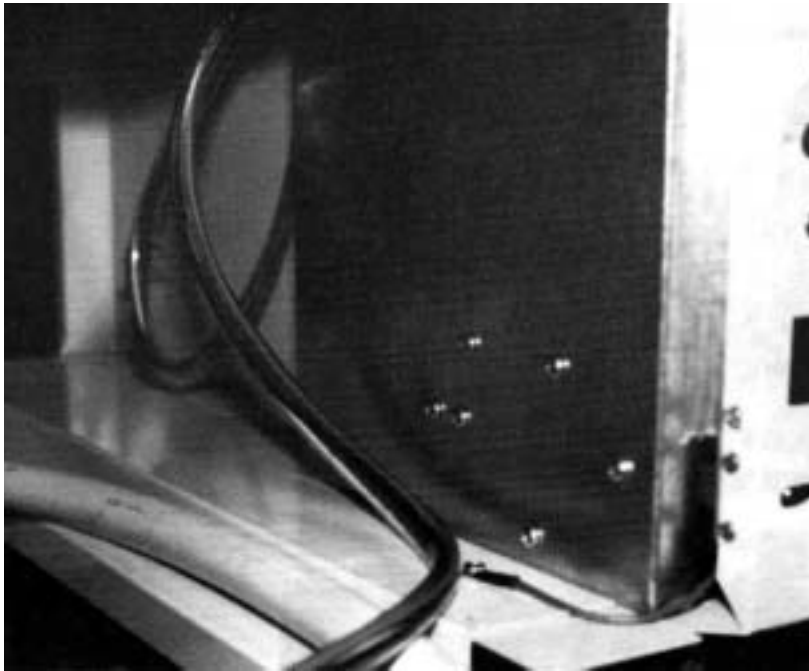

The ballast is located in the machinery compartment inside the electrical box.

1. Disconnect the power to the cabinet.
2. Remove the front grill.
3. Remove the electrical wiring box.
4. Disconnect the leads to the ballast.
5. Replace the ballast with correct part.
6. Reconnect the leads to the ballast.
7. Replace the electrical box assembly.
8. Replace the front grill.
9. Reconnect the power to the cabinet.

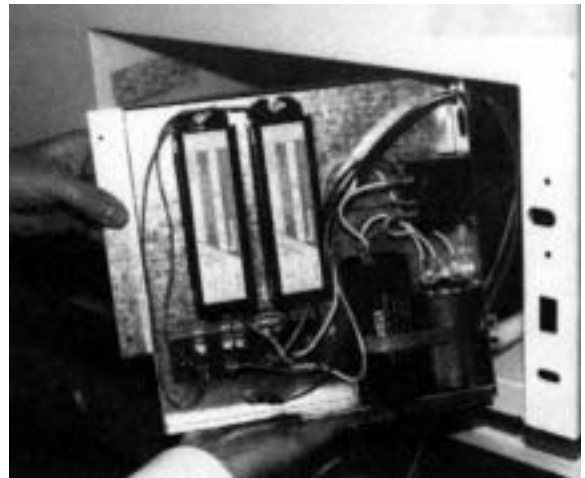

METERING DEVICE/HEAT EXCHANGER REPLACEMENT

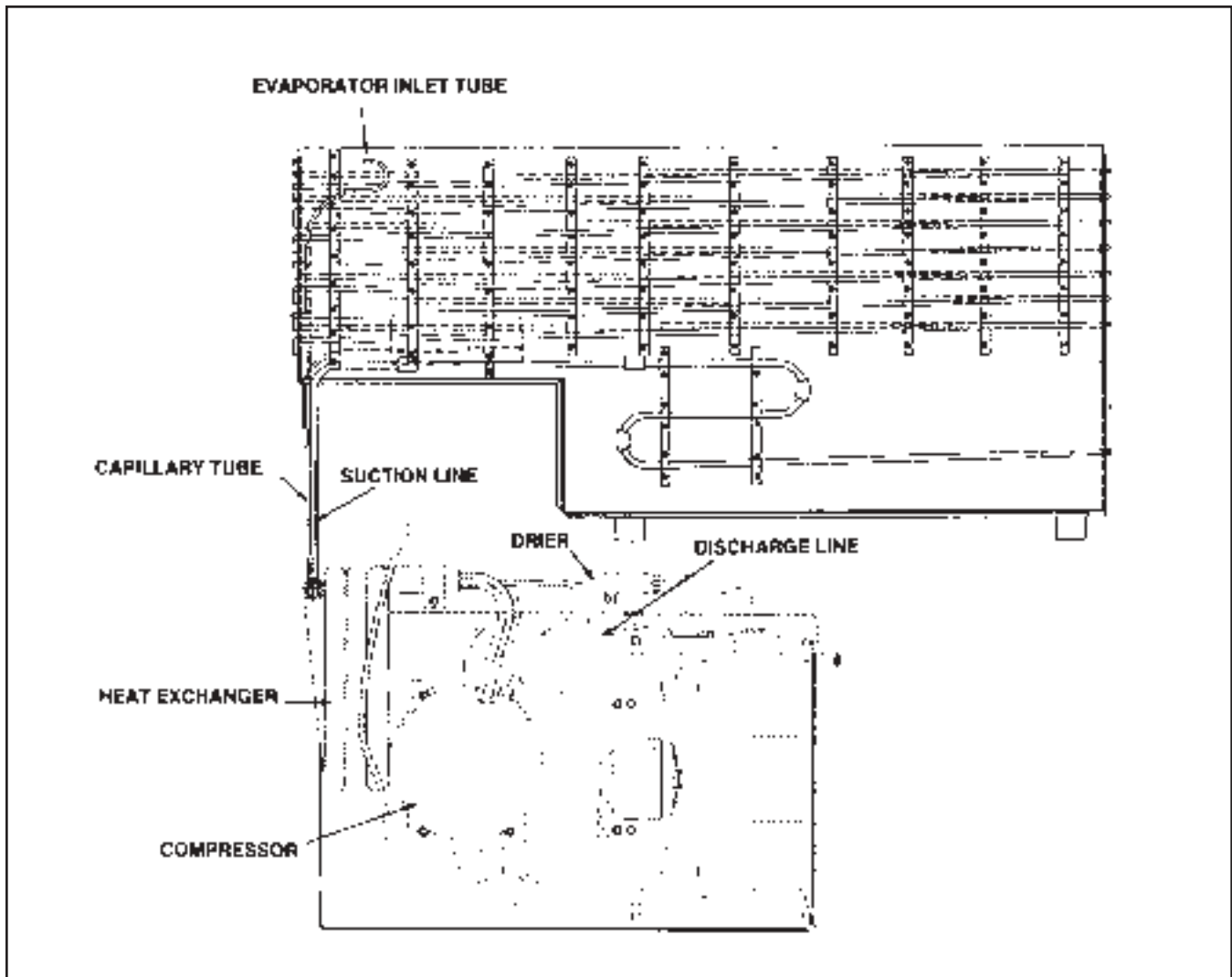

1. Disconnect power to the cabinet.
2. Pull out the condensing unit.
3. Disconnect the liquid line.
4. Disconnect the suction line at the compressor.
5. Cut off the evaporator inlet tube about five inches down below the point where it comes out of the cabinet.
6. Remove the capillary tube from the inside of the evaporator inlet tube.
7. Connect the end of the capillary on the new heat exchanger to the evaporator inlet tube.
8. Connect the suction line to the compressor valve and the capillary line to the bottom of the drier. Replace the drier.
9. Evacuate and recharge.
10. Secure short lengths of insulating tubing provided around exposed tubing in place with tape and seal to bottom of the cabinet with permagum which is provided.
11. Reconnect power to the cabinet.

TROUBLESHOOTING GUIDE

TROUBLE	COMMON CAUSE	REMEDY
UNIT WILL NOT RUN.	Blown Fuse.	Check power outlet for ""live"" circuit. If outlet is ""dead"" but building has power, replace the fuse. Try to determine the cause of the overload or short circuit.
	Low Voltage.	Check outlet with voltmeter, should check 115V plus or minus 10%. If circuit overloaded, either reduce load or have electrician install separate circuit. If unable to remedy any other way, install auto-transformer.
	Open motor or temperature control.	Jumper across terminals of control. If unit runs and connections are all tight, replace control. Power element may have lost charge or points may be dirty. Repair or replace thermostat.
	Open relay.	Check relay. Replace if necessary.
	Open overload.	Check overload. Replace if necessary.
	Open compressor.	Check compressor. Replace if necessary.
	Open service cord.	Check with ohmmeter at unit. If no circuit and current is indicated at outlet, replace or repair.
	Broken lead to compressor or cold control.	Repair or replace broken leads.
	Service cord not plugged in.	Plug in cord.
CABINET IS TOO WARM.	Thermostat position set to warm, not allowing unit to operate often enough.	Turn knob to colder position.
	Fan motor not running.	Check and replace fan motor if necessary.
	Shortage of refrigerant.	Check for leaks. Repair, evacuate and recharge system.
	Not enough air circulation around cabinet.	Relocate cabinet or provide clearance to allow sufficient circulation.
	Dirty condenser or obstructed condenser ducts.	Clean the condenser and the ducts.
	Thermostat control capillary not properly installed.	Refer back to removal/installation instructions detailed in this manual

TROUBLE	COMMON CAUSE	REMEDY
CABINET RUNS CONTINUOUSLY.	Not enough air circulation around cabinet or air circulation is restricted.	Relocate cabinet or provide proper clearances around cabinet. Remove restriction.
	Cooling large quantities of product or heavy loading.	Explain to customer that heavy loading causes long running time.
	Refrigerant charge.	Undercharged or overcharged. Check, evacuate and recharge with proper charge.
	Room temperature too warm.	Ventilate room as much as possible.
	Thermostat defective.	Check control. If it allows unit to operate all the time, replace control.
NOISY OPERATION	Loose flooring or floor not firm.	Tighten flooring or brace floor.
	Tubing contacting cabinet or other tubing.	Move tubing gently!
	Cabinet not level.	Level cabinet.
	Compressor mechanically grounded.	Replace compressor mounts.
	Fan hitting drain pan or mechanically grounding.	Move fan.
	Shipping bands rubbing.	Make sure all shipping bands have been cut and removed.
	Loose fan blades or motor.	Tighten fan blades and/or motor.
	Loose parts or refrigeration or electrical lines out of place.	Tighten all loose fittings. Move misplaced lines.
UNIT CYCLES ON OVERLOAD	Short relay.	Replace relay.
	Weak overload protector.	Replace overload protector.
	Low voltage.	Check outlet with voltmeter. Under load, voltage should be 115V plus or minus 10%. Check for several cabinets on same circuit or extremely long or undersized cord being used.
	Short compressor.	Check with meter and also ground before replacing.

TROUBLE	COMMON CAUSE	REMEDY
CABINET LIGHTS WILL NOT WORK.	Light switch OFF or defective	Try new bulb or bulbs. Inspect lamp holders for signs of bad connections.
COMPRESSOR WILL NOT RUN.	Incorrect voltage.	Check voltage to compressor terminal board. Voltage must be plus or minus 10% of nameplate voltage.
UNIT RUNS TOO MUCH.	Abnormally high, heavy use of cabinet.	Heavy useage requires more operation. Check useage and correct or explain.
	Shortage of refrigerant. Unit must run longer and will operate at a lower than normal suction pressure.	Put in the normal charge and check for leaks.
	Overcharge of refrigerant. Excessively cold or frosted suction line results in lost refrigeration effort.	Remove excess charge.
	Restricted air flow over condenser or air or non-condensable gases in system.	Correct the condition.
	High room temperature.	Check for temperature variance. Correct condition.
	Compressor inefficient.	Replace.
	Thermostat setting too cold.	Raise setting.
UNIT SHORT CYCLES.	Cycling on overload because of high/low line voltage with variance more or less than 10% from 115 volts. May also be caused by head pressures too high.	Check voltage, head pressure and air passages. Repair and correct condition.
PRODUCT TOO COLD.	Thermostat set too cold.	Set warmer. (Setting #1 is the warmest; #7 is the coldest.)
	Thermostat bulb contact bad.	If the bulb contact is bad, the bulb temperature will lag behind the sleeve temperature causing the unit to run longer and make the cabinet too cold. Make sure bulb makes good contact with the bulb well.
	Room temperature abnormally low.	Correct conditions.
PRODUCT TOO WARM.	Thermostat set too warm.	Set colder. (Setting #1 is warmest; #7 the coldest.)
	Thermostat contact points dirty or burned.	Clean or replace thermostat.
	Thermostat out of adjustment.	Readjust or change thermostat.
	Excessive service load or abnormally high room temperature.	Educate customer about problems that are caused by improper loading and excessive room temperature fluctuations.
	Excessive frost accumulation.	Defrost the cabinet.

TROUBLE	COMMON CAUSE	REMEDY
WON'T START. WON'T HUM.	Open the circuit.	Check wiring, fuses, receptacle.
	Protector open.	Wait for reset — check current.
	Control contacts open.	Check control, check pressures.
	Open circuit in stator.	Replace stator or compressor.
WON'T START; HUMS INTERMITTENTLY. (cycling on protector.)	Improperly wired.	Check wiring against diagram.
	Low line voltage.	Check main line voltage, determine location of voltage drop.
	Open starting capacitor.	Replace starting capacitor.
	Relay contacts not closing.	Check by operating manually. Replace relay if defective.
	Open circuit in start winding.	Check stator leads. If leads are all right, replace compressor.
	Stator winding grounded (normally will blow fuse.)	Check stator leads. If leads are all right, replace compressor.
	High discharge pressure.	Eliminate cause of excessive pressure. Make sure discharge shut-off and receiver valves are open if applicable.
	Tight compressor.	Check oil level — correct binding condition, if possible. If not, replace compressor.
	Weak starting capacitor or one weak capacitor of a set.	Replace.
COMPRESSOR STARTS; MOTOR WON'T GET OFF STARTING WINDING.	Low line voltage.	Bring up voltage.
	Improperly wired.	Check wiring against diagram.
	Defective relay.	Check operation — replace relay if defective.
	Running capacitor shorted.	Check resistances. Replace capacitor if defective.
	Starting and running windings shorted.	Check capacitance — replace if defective.
	Starting capacitor weak or one of a set open.	Check capacitance — replace if defective.
	High discharge pressure.	Check discharge shutoff valves. Check pressure.
	Tight compressor.	Check oil level. Check binding. Replace compressor if necessary.

TROUBLE	COMMON CAUSE	REMEDY
COMPRESSOR STARTS & RUNS BUT CYCLES ON PROTECTOR.	Low line voltage.	Bring up voltage.
	Additional current passing through protector.	Check for added fan motors and pumps connected to wrong side of protector.
	Suction pressure too high.	Check compressor for proper application.
	Discharge pressure too high.	Check ventilation, restrictions and overcharge.
	Protector weak. Running capacitor defective.	Check current — replace protector if defective. Check capacitance. Replace if defective.
	Stator partially shorted or grounded.	Check resistances; check for ground. Replace if defective.
	Inadequate motor cooling.	Correct cooling system.
	Compressor tight.	Check oil level. Check for binding condition.
	Unbalanced line (three-phase).	Check voltage of each phase. If not equal, correct condition of unbalance.
	Discharge valve leaking or broken.	Replace valve plate.
STARTING CAPACITORS BURNT OUT.	Short cycling.	Reduce number of starts to 20 or less per hour.
	Prolonged operation on starting winding.	Reduce starting load (install crankcase pressure limit valve), increase voltage if low — replace relay if defective.
	Relay contacts sticking.	Clean contacts or replace relay.
	Improper relay or incorrect relay setting.	Replace relay.
	Improper capacitor.	Check parts list for proper capacitor rating — mfd. and voltage.
	Capacitor terminals shorted by water.	Install capacitors so terminals won't be wet.

TROUBLE	COMMON CAUSE	REMEDY
RUNNING CAPACITORS BURNT OUT.	Excessive line voltage.	Reduce the line voltage to not over 10% above rating of motor.
	High line voltage and light load.	Reduce voltage if over 10% excessive.
	Capacitor voltage rating too low.	Install capacitors with recommended voltage rating.
	Capacitor terminals shorted by water.	Install capacitors so terminals will not be wet.
RELAY BURNT OUT.	Low line voltage.	Increase voltage to not less than 10% under compressor motor rating.
	Excessive line voltage.	Reduce voltage to maximum of 10% above motor rating.
	Incorrect running capacitor.	Replace running capacitor with correct mfd. capacitance.
	Short cycling.	Reduce number of starts per hour.
	Relay vibrating.	Mount relay rigidly.
	Incorrect relay.	Use relay recommended for specific motor compressor.

FLUORESCENT LAMPS - TROUBLESHOOTING GUIDE

The manufacturer uses standard fluorescent lamps in all of its applications. Standard one- and two- lamp ballast circuits are used. Replacement lamps should be purchased over the counter from a local electrical wholesaler. The table below indicates general problems that may be encountered with fluorescent lighting applications, possible causes, and corrective maintenance suggestions.

TROUBLE	COMMON CAUSE	REMEDY
NORMAL END OF LIFE. Lamp won't operate. Flashes momentarily and goes out or blinks on and off. Ends probably blackened.	Normal failure. Active material on cathodes exhausted.	Replace lamp promptly.
SHORT LIFE.	Wrong lamp type used.	Replace with lamp type marked in owner's manual.
	Wrong type of starter.	Replace with correct starter.
	Ballast not supplying the specified electrical values.	Replace with correct ballast for rating for lamp size.
	Wrong type of ballast used.	Replace ballast with proper type.
	Too low or too high voltage.	Check primary voltage with range specified on ballast name plate.
	Poor circuit contact. (likely at lampholders)	Lampholders should be rigidly mounted and lamp securely seated.
	Ballast improperly or incompletely connected.	Study ballast label wiring diagram and check connections.
Too many lamp starts.	Average life for most lamps is dependant on number of starts and hours of operation.	
END BLACKENING. Dense blackening at one end or both, extending 2" to 3" from base.	Normal end of life.	Replace lamp promptly.
	Mercury deposit — generally within 1" of lamp end.	Should evaporate as lamp is operated.
	Poor circuit contact likely at the lampholder.	Lampholders should be rigidly mounted and lamp securely seated.
	Ballast improperly or incompletely connected.	Study ballast wiring instructions and check connections.
	Wrong type lamp used.	Replace with correct lamp type.
	Wrong type of starter or defective starter causing on /off blinking or prolonged flashing at each start.	Replace with proper starter.
	Ballast intalled not supplying the specified electrical values.	Replace with ballast of correct rating for lamp size.
	Line voltage too low or too high.	Check line voltage with range specified on ballast plate.
	Ballast improperly or incompletely connected.	Study ballast label wiring instuctions and check connections.

TROUBLE	COMMON CAUSE	REMEDY
NO STARTING EFFORT OR SLOW STARTING.	Open lamp cathode circuit due to broken cathode, air leak, or open weld.	If open, circuit is shown by continuity test or by viewing end of bulb against a pinhole of light. Replace lamp.
	Wrong lamp type used.	Replace with lamp type indicated in owner's manual.
	Starter at end of life.	Replace starter.
	Starter sluggish.	Replace starter.
	Ballast installed not supplying the specified electrical values.	Replace with certified ballast of correct rating for lamp size.
	Temperature cold air contact to bulb.	Correct installation of lamp protection tubes, or shields to prevent cold air effects.
	Circuit voltage.	Check voltage and correct if possible.
DECREASED LIGHT OUTPUT. Full illumination of bulbs requires correct assembly of all components of lighting system.	Temperature operation, cold air affects lamp performance.	Properly install jacketed lamps where applicable.
	Circuit voltage.	Check voltage and correct if possible.
	Ballast improperly or incompletely connected.	Study ballast label wiring instructions and check connections.
	Dust or dirt on lamp or fixture.	Clean.
BLINKING ON/OFF. Accompanied by shimmering effect during "lighted" period.	Normal failure. Active material on cathodes exhausted.	Replace lamp promptly.
	Possible lamp fault.	Replace lamp. Investigate further if successive lamps blink or flicker in same lampholders.
	Wrong type of starter or defective starter.	Replace with proper starter.
	Ballast installed not supplying the specified electrical circuit.	Replace with correct ballast with correct rating for lamp size.
	Circuit voltage.	Check voltage and correct if possible.
	Loose circuit contact.	Lampholders should be rigidly mounted and lamp securely seated.
OVERHEATED BALLAST.	Wrong lamp type used.	Replace with correct lamp number located in owner's manual.
	Wrong ballast used. Wrong voltage rating.	Replace ballast.
	Circuit voltage.	Check voltage and correct to design specification.
	Ballast improperly or incompletely connected.	Study ballast label. Correct if installed wrong.

SECTION IV

Parts List

CABINET PARTS

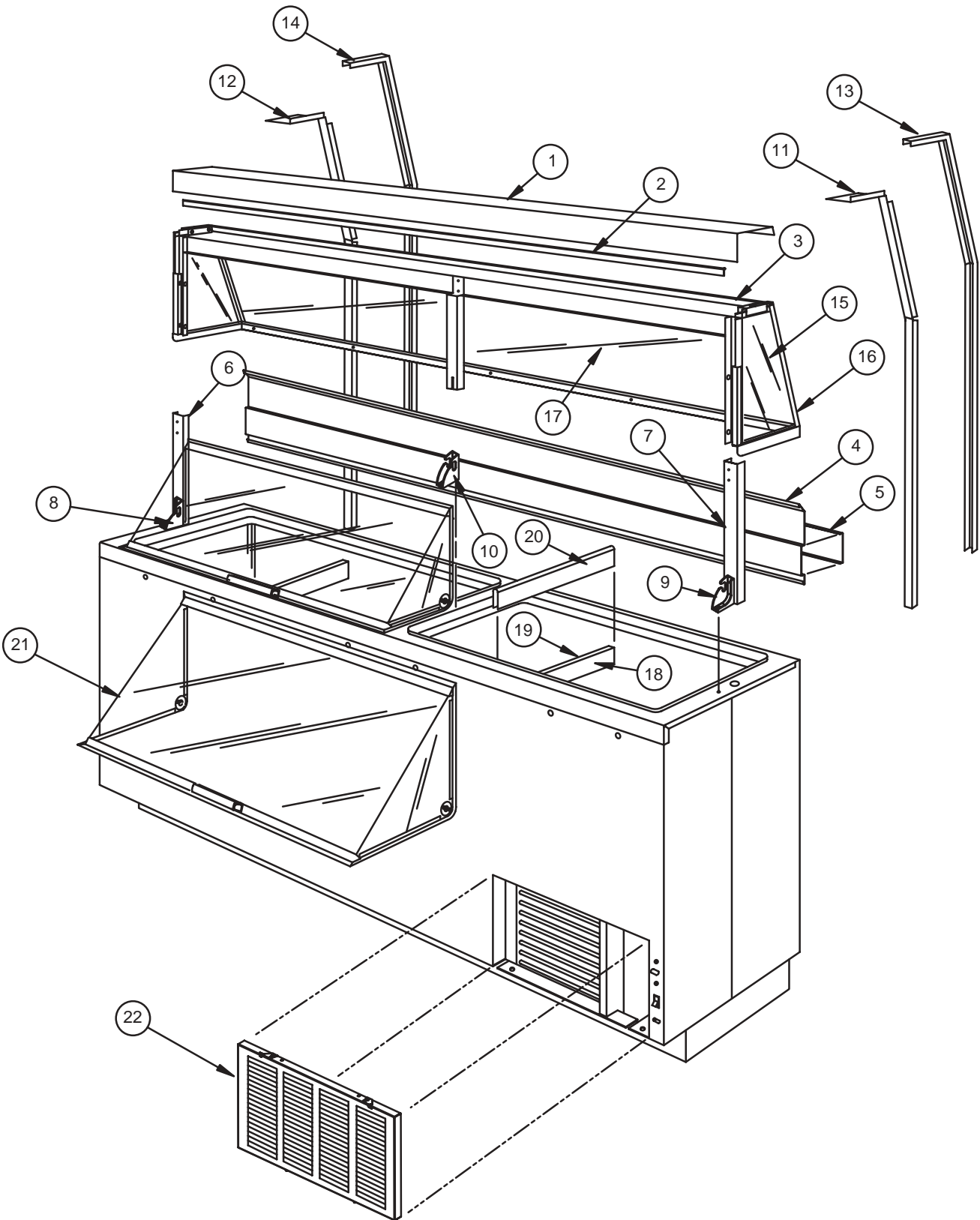

CABINET PARTS LIST

CABINET PARTS				MODEL NO.		MODEL NO.	
Dipping Cabinets				BRT68 EBRT68 KBRT68		BRT90 EBRT90 KBRT90	
	PART NUMBER	DESCRIPTION	U/M	QTY	GR.#	QTY	GR.#
1	05-1188-*	Canopy Top	EA	1	-01	1	-02
2	44-0862-06	Upper Lid Seal	IN	1	-	1	-
3	51-1504-*	Lamp Fixture As'y	EA	1	-01	1	-02
4	50-1078-00	Lower Front Trim Rail	EA	1	-		
	137F02	Lower Front Trim Rail	EA			1	-
5	217F03	Lower Trim Filler	EA	1	-		
	137F03	Lower Trim Filler	EA			1	-
6	05-1189-02	Outside Post, RH	EA	1	-	1	-
7	05-1189-01	Outside Post, LH	EA	1	-	1	-
8	10-1158-02	Pivot Bracket, RH	EA	1	-	1	-
9	10-1158-01	Pivot Bracket, LH	EA	1	-	1	-
10	10-1157-00	Pivot Bracket, Center	EA	1	-	1	-
11	50-4010-01	Trim Support, LH	EA	1	-	1	-
12	50-4010-02	Trim Support, RH	EA	1	-	1	-
13	137F0004-02	Trim, LH End	EA	1	-	1	-
14	137F0005-02	Trim, RH End	EA	1	-	1	-
15	42-0133	Glass, End	EA	2	-	2	-
16	44-0913	Channel, Glass	EA	2	-	2	-
17	20-0083-*	Glass, Front	EA	1	-01	1	-02
18	01-0986-00	Cover, Cold Plate	EA	2	-	3	-
19	01-0987-00	Cover, Cold Plate	EA	2	-	3	-
20	06-0587-00	Frost Shield, Cold Plate	EA	2	-	3	-
21	51-1507-*	Lid Assembly	EA	2	-05	2	-06
22	50-4192-01	Grill Panel Assembly	EA	2	-	2	-

MISCELLANEOUS CABINET PARTS	
Not Shown	
All Models	
PART NUMBER	DESCRIPTION
137A04	Container Clamp Asm Complete
33-0302	Can Clamp Frame
137A05	Container Clamp Band Assy
137A0501	Band / Container Clamp
137A0201	Hinge / Container Clamp Band
33-0303	Band Lock Arm
356A09	Container Mtg Knob
47-0064	Night Cover
33-0245	Frost Shield Hook
90-0125	Bottom Pad Insert
26-0632-00	Baskin Robbins Nameplate
26-6504-00	Double Sided Tape

LAMP ASSEMBLY PARTS

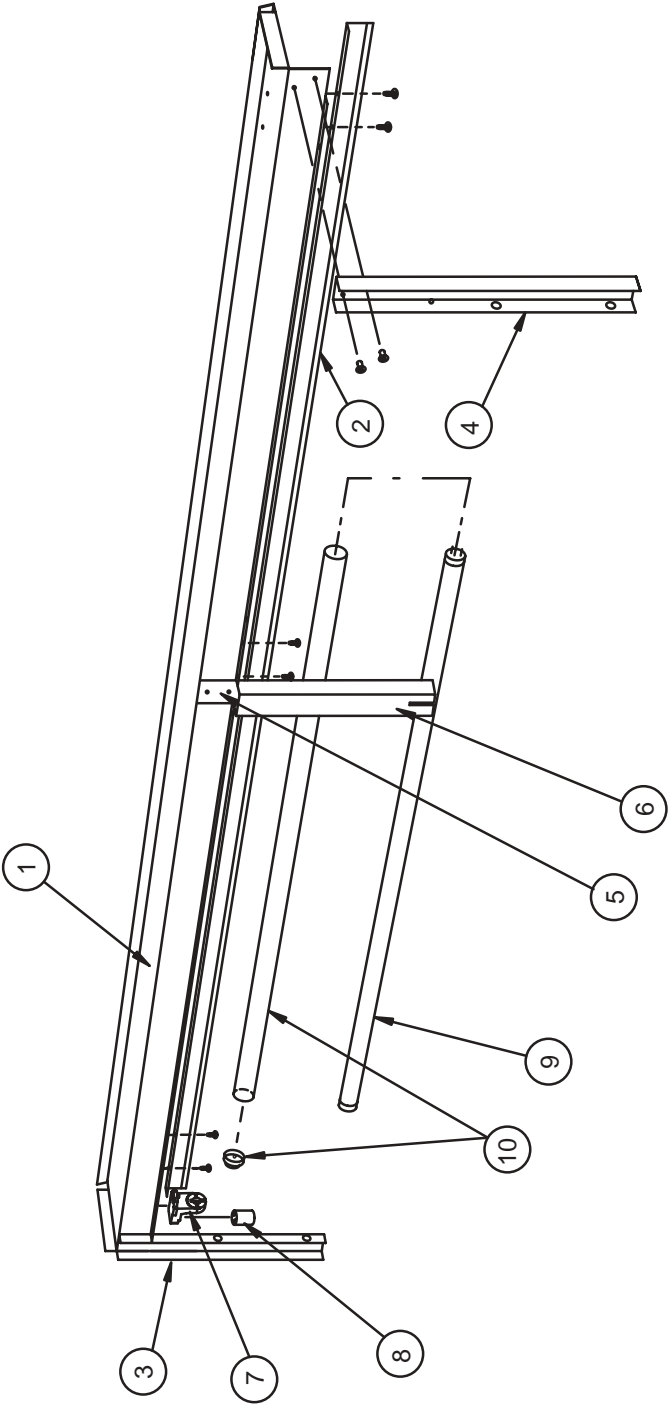

LAMP ASSEMBLY PARTS LIST

LAMP ASSEMBLY PARTS Dipping Cabinets		MODEL NO.			MODEL NO.		
		BRT68	EBRT68	KBRT68	BRT68	EBRT68	KBRT68
PART NUMBER	DESCRIPTION	U/M	QTY	GR.#	QTY	GR.#	
1	01-1132-* Lamp Channel	EA	1	-01	1	-02	
2	05-1036-* Light Shield	EA	1	-03	1	-04	
3	05-1213-02 Inside Post LH	EA	1	-	1	-	
4	05-1213-01 Inside Post RH	EA	1	-	1	-	
5	05-1192-02 Inside Post, Center	EA					
6	05-1193-02 Outside Post, Center	EA					
7	19-1975-00 Lampholder	EA	1	-	2	-	
	19-0088-00 Lampholder, W/Starter Soc.	EA	1	-	2	-	
8	19-0145-00 Starter, FS4	EA	1	-			
9	19-0151-00 Lamp, 40 Watt	EA					
10	10-0445-00 Lamp Shield & Cap, 40 Watt	EA					

CONDENSING UNIT PARTS

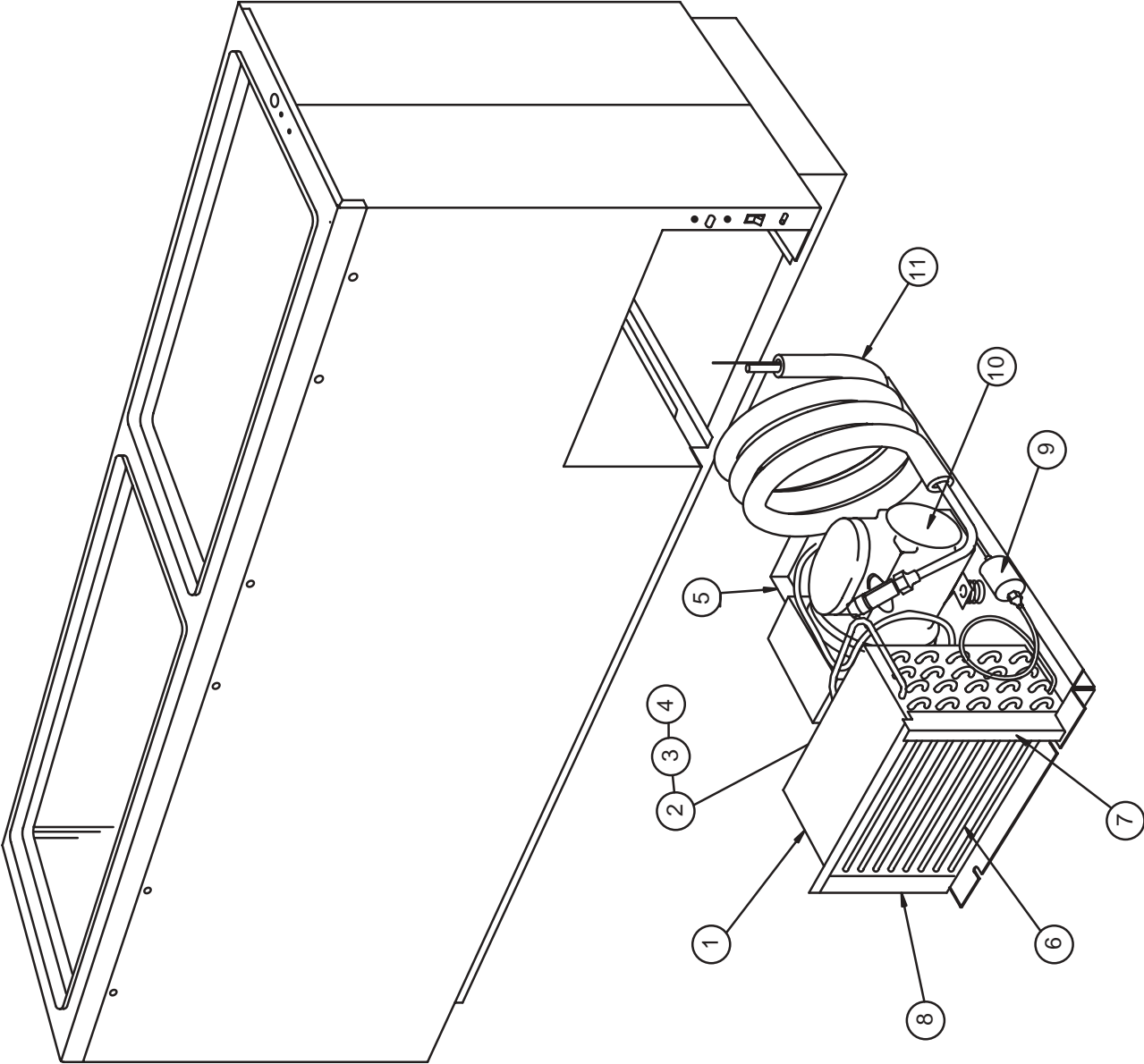

CONDENSING UNIT PARTS LIST

CONDENSING UNIT PARTS										
Dipping Cabinets										
PART NUMBER	DESCRIPTION	U/M	MODEL NO. BRT68 BRT68P BRT68W		MODEL NO. BRT90 BRT90P BRT90W		MODEL NO. EBRT68 KBRT68P		MODEL NO. EBRT90 KBRT90P	
			QTY	GR.#	QTY	GR.#	QTY	GR.#	QTY	GR.#
	51-1509-*	Condensing Unit As'y	EA	1	-05	1	-06			
	51-1510-00	Condensing Unit As'y	EA					1	-	1
1	02-0255-00	Condenser Shroud	EA	1	-	1	-			
	02-1007-00	Condenser Shroud	EA					1	-	1
2	19-0933-00	Condenser Fan Motor	EA	1	-	1	-			
	19-0934-00	Condenser Fan Motor	EA					1	-	1
3	19-0101-00	Condenser Fan Blade	EA	1	-	1	-			
	19-0925-00	Condenser Fan Bracket	EA	1	-	1	-			
5	50-0165-02	Unit Base Plate Weld Asy	EA	1	-	1	-			
	51-0709-*	Condenser Coil	EA	1	-02	1	-03			
6	18-0543-00	Condenser Coil	EA					1	-	1
	02-0274-00	Baffle, RH	EA	1	-	1	-			
7	02-0275-00	Baffle, RH	EA					1	-	1
	02-0851-00	Baffle, LH	EA					1	-	1
9	12-3024	Filter Drier	EA	1	-	1	-			
	18-1122-00	Filter Drier	EA					1	-	1
10	16-0313-00	Compressor	EA	1	-	1	-			
	16-0301-00	Compressor	EA					1	-	1
	17-0316-00	Motor Protector	EA	1	-	1	-			
	17-0300-00	Start Relay	EA	1	-	1	-			
15-0325		Cover, Comp Terminals	EA	1	-	1	-			
	15-0326	Strap, Cover	EA	1	-	1	-			
11	50-4035-00	Heat Exchange, Coil	EA	1	-	1	-			
	50-3475-02	Heat Exchange, Coil	EA					1	-	1

ELECTRICAL PARTS

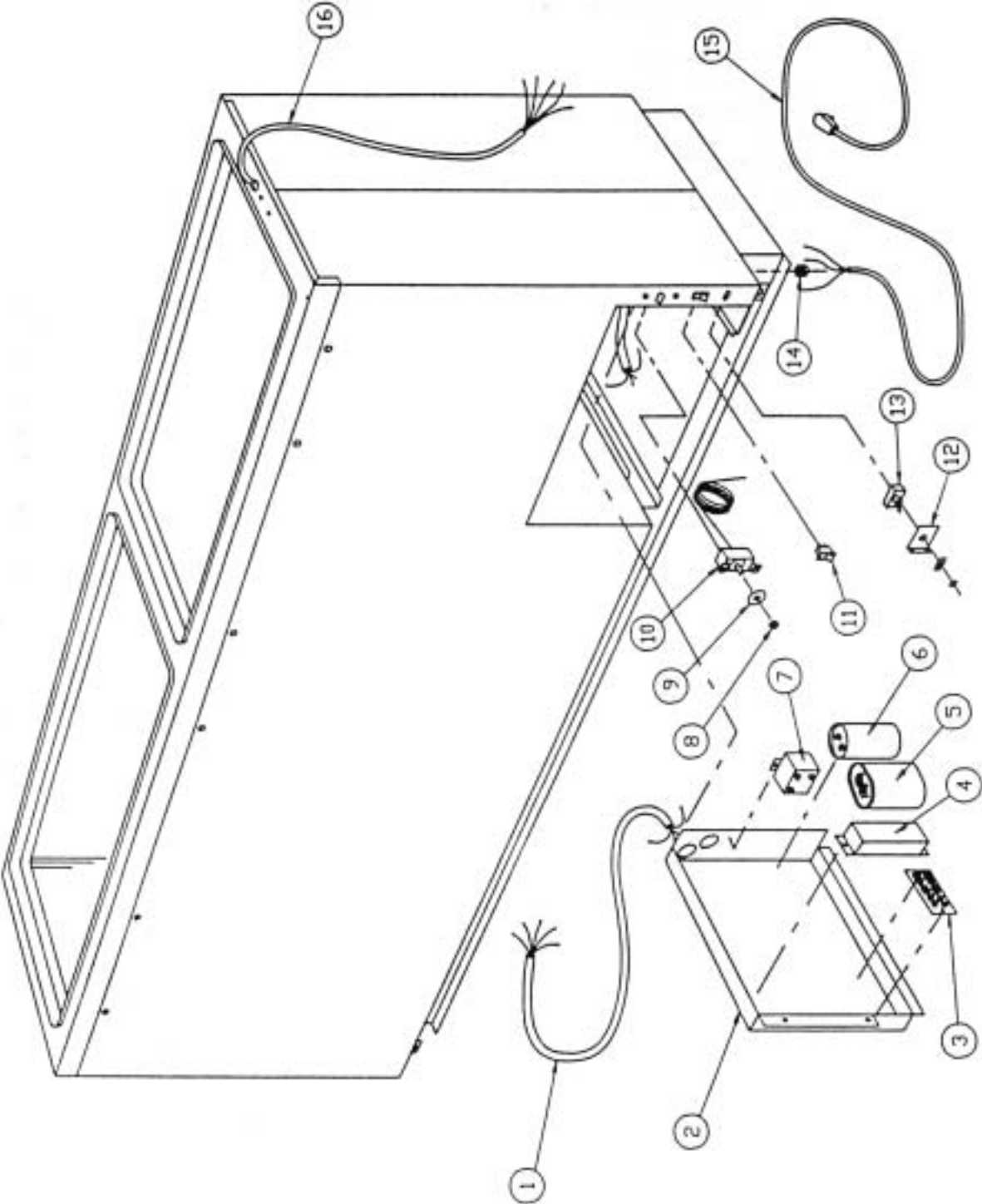

ELECTRICAL PARTS LIST

ELECTRICAL PARTS Dipping Cabinets		PART NUMBER	DESCRIPTION	U/M	MODEL NO.		MODEL NO.		MODEL NO.		MODEL NO.		MODEL NO.		
					BRT68 BRT68P BRT68W	BRT90 BRT90P BRT90W	EBRT68 EBRT68P	EBRT90 EBRT90P	KBRT68 KBRT68P	KBRT90 KBRT90P	QTY	GR.#	QTY	GR.#	QTY
1	19-1148-00	Wire Harness, Compr	EA	1	-	-	-	-	-	-	-	-	-	-	-
	19-1149-00	Wire Harness, Compr	EA				1	-	1	-	1	-	1	-	
2	02-0835-01	Electrical Box	EA	1	-	1	-	1	-	1	-	1	-	1	-
3	19-1414-00	Terminal Board	EA	1	-	1	-	1	-	1	-	1	-	1	-
	19-0458-00	Ballast,	EA	2	-	2	-								
	19-1329-00	Ballast,	EA				2	-	2	-					
	19-0539-00	Ballast,	EA								2	-	2	-	
	17-0320-00	Capacitor, Run	EA	1	-	1	-								
	17-0283-00	Capacitor, Run	EA				1	-	1	-	1	-	1	-	
	17-0319-00	Capacitor, Start	EA	1	-	1	-								
	19-1327-00	Capacitor, Start	EA				1	-	1	-					
	17-0168-00	Capacitor, Start	EA								1	-	1	-	
	17-0306-00	Start Relay	EA				1	-	1	-	1	-	1	-	
7	43-0182	Grommet, Temp Control	EA	1	-	1	-	1	-	1	-	1	-	1	-
9	82-0141	Dial Plate, Temp Control	EA	1	-	1	-	1	-	1	-	1	-	1	-
	19-1222-00	Temperature Control	EA	1	-	1	-	1	-	1	-	1	-	1	-
10	19-0659-00	Switch, Light	EA	1	-	1	-	1	-	1	-	1	-	1	-
11	01-1136-00	Bracket, Power Switch	EA	1	-	1	-	1	-	1	-	1	-	1	-
12	19-0103-00	Switch, Power Supply	EA	1	-	1	-	1	-	1	-	1	-	1	-
13	19-0813-00	Strain Relief	EA	1	-	1	-	1	-	1	-	1	-	1	-
14	19-0620	Power Supply Cord	EA	1	-	1	-								
	19-1349-00	Power Supply Cord	EA				1	-	1	-	1	-	1	-	
15	19-0915-00	Wire Harness, Cabinet	EA	1	-	1	-	1	-	1	-	1	-	1	-

LID PARTS

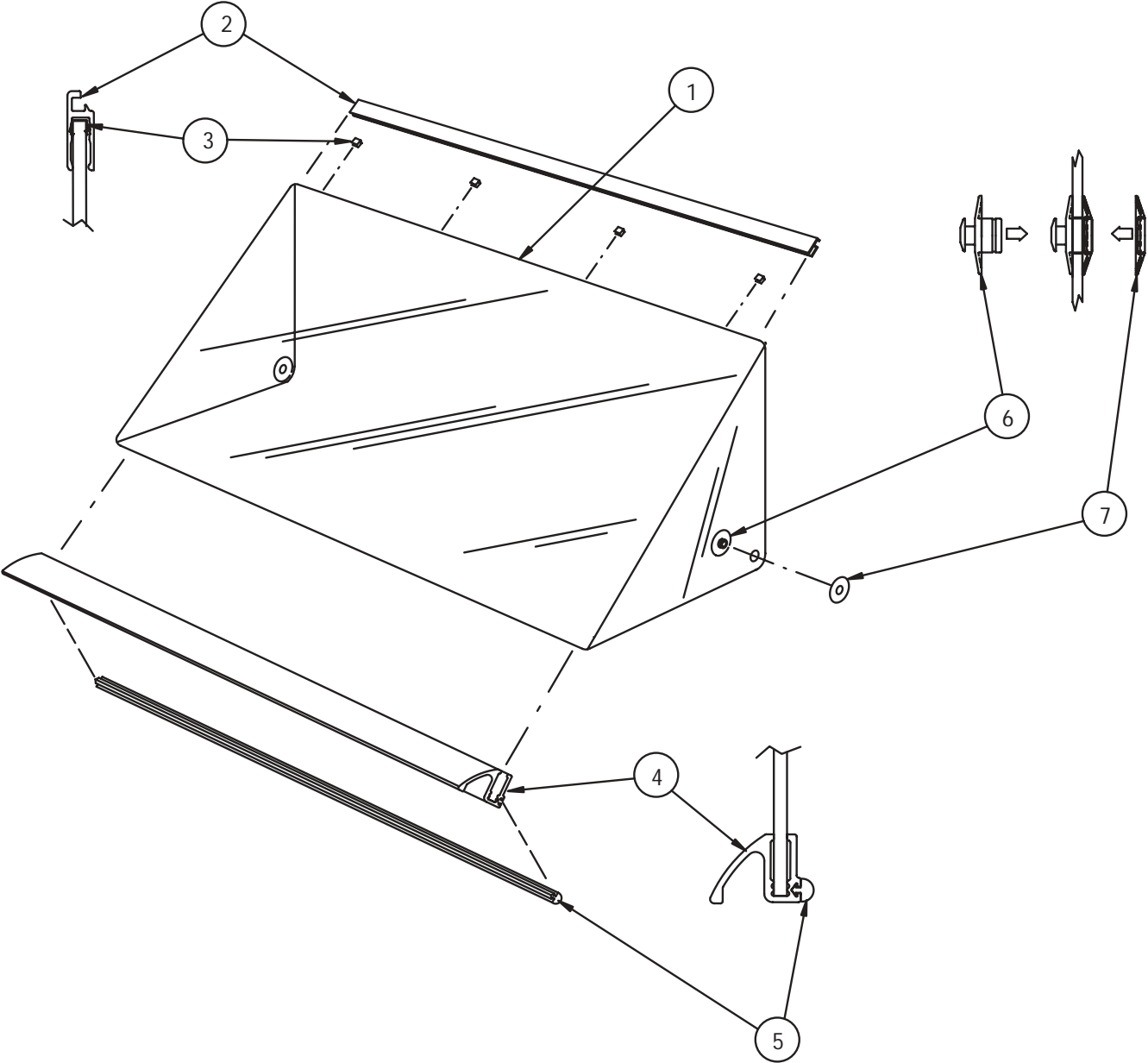

LID PARTS LIST

LID PARTS Dipping Cabinets				MODEL NO.		MODEL NO.	
				BRT68 BRT68P BRT68W EBRT68 EBRT68P KBRT68 KBRT68P		BRT68 BRT68P BRT68W EBRT68 EBRT68P KBRT68 KBRT68P	
	PART NUMBER	DESCRIPTION	U/M	QTY	GR.#	QTY	GR.#
1	10-1142-*	Lid, Plexiglas	EA	1	-02	1	-01
2	08-0517-*	Lid Frame, Top	EA	1	-03	1	-04
3	23-0164-00	U-Clip	EA	10	-	10	-
4	08-0520-*	Lid Frame, Handle	EA	1	-03	2	-04
5	09-0219-00	Bumper, Lid Front	FT	2.489	-	3.66	-
6	10-1156-00	Pivot Bushing, Male	EA	2	-	2	-
7	10-1135-02	Pivot Fushing,Female	EA	2	-	2	-



CARRIER COMMERCIAL REFRIGERATION, INC.

Providing BEVERAGE-AIR • FRIGIDAIRE • KELVINATOR • UNIVERSAL NOLIN Products/Services
P.O. Box 5932

Spartanburg, S.C. 29304-5932 • (800) 684-1199