



## ***PRODUCT MANUAL - M090***

### ***MODEL 203/266 ELECTRIC CAN OPENER***



## I. SPECIFICATIONS

MODEL NO.	203	266
POWER	115 VOLT, 3 AMP, 50-60HZ	115 VOLT, 3 AMP, 50-60HZ
REQUIREMENTS	230 VOLT, 1.5 AMP, 50-60 HZ	230 VOLT, 1.5 AMP, 50-60 HZ
NORMAL SPEED	200-250 RPM	200-250 RPM
LOW SPEED	150-200 RPM	NONE
SIZE	4 - 3/8" W X 7" D X 12" H	4 - 3/8" w X 7" D X 12" H
	(111mm x 178mm x 305mm)	(111mm x 178mm x 305mm)
WEIGHT	13 lbs. (5.85 kg.)	12-3/4 lbs. (5.75 kg.)

## II. CAN OPENER DESCRIPTION

The Models 203/266 electric can openers, manufactured by the Edlund Company, are approved by the appropriate certifying organizations. The two models differ only in that the model 266 can opener operates at a single speed while the model 203 can opener operates at the normal speed and a slower speed so that it is easier to open smaller or difficult to open cans.

The model 203/266 can openers are table-type openers with a weighted base to offset the weight of a full No. 10 can. The external housing and knife holder are manufactured from stainless steel.

## III. CAN OPENER OPERATION

To operate, plug the power cord into a grounded outlet with the same voltage as listed on the back of the can opener. If you are opening a standard seven-inch high no. 10 can, slide the can against the can opener drive gear and push the handle back to its locked-down position.

The can opener motor will start after the can bead is captured between the knife and drive gear and before the knife pierces the can. The can will start to rotate, and after one full revolution the lid will be severed from the can. After the lid is completely severed from the can, pull the handle forward to stop the can opener motor. If for some reason the lid is not completely severed or if the can is ejected from the gear, consult the maintenance instruction and/or trouble-shooting guide later in this manual.

To open a shorter can, the operator must support the can on his left or right hand, place the bead or rim of can's top over the drive gear, and push the handle back to its locked down position so that the can is held firmly between the knife and gear. The supporting hand should then be removed completely from the can until the can lid is completely severed from the can. If the operator restricts the rotation of the can by holding on to the can, the can opener may reject the can. After the can is opened pull forward on the handle and grasp the can simultaneously. If a small can is not opened properly, consult the troubleshooting guide.

**CAUTION: SEVERED CAN LIDS HAVE "CUTTING" EDGES. USE OF A PROTECTIVE GLOVE OR TONGS IS ADVISED WHEN HANDLING LIDS.**

## IV. CLEANING AND MAINTENANCE INSTRUCTIONS

The can openers must be kept clean, not only for the obvious reasons of sanitation but more important, for operational reasons as well. An electric can opener's rotary knife must rotate freely for the can opener to operate properly. If the knife is bound by residual food product, the knife will not rotate and wear will not be distributed around the periphery of the knife.

**More important than the wear, a non-rotating knife will no longer be shearing the metal can top as designed and metal slivers may occur.**

The knife (K006) should be removed often by unscrewing the knife stud (S196) from the knife holder (H072) so that the knife, knife stud and knife holder can be properly cleaned. Clean the knife holder by wiping off the knife holder protrusion with a damp cloth. To greatly reduce the chances of the knife sticking and rusting after cleaning, lubricate the knife stud, knife holder protrusion, and hub of the knife with vegetable oil. Replace the knife with the smaller diameter hub meeting the machined boss of the knife holder.

**Be sure the knife is rotating easily after parts are reassembled.**

The factory-made edge of the can opener knife is designed to shear through the metal can lid. It will not function properly if allowed to become dull or nicked. If knife becomes excessively dull, it will be difficult to pierce the can and the knife will no longer sever the lid completely at the end of the cut. Replace the knife when it becomes excessively dull or if nicks occur on the cutting edge.

**Warning: The can opener knife is not designed to be sharpened. If the knife-edge is made truly burr-free it can shave off slivers.**

The teeth of the drive gear must be clean and burr free. Wipe off the drive gear with a damp cloth after every use to remove the build-up of food residues. Coat the drive gear with vegetable oil to prevent rusting. If the drive gear starts to slip on the bead of the can its teeth may be worn. To replace it, give the gear a quick rap counter clockwise with Edlund gear removal tool (T140) until it can be removed (otherwise, turning the gear will only rotate the motor), then screw a new drive gear on clockwise until it is up against the output shaft shoulder. Verify gap between gear and knife spacing.

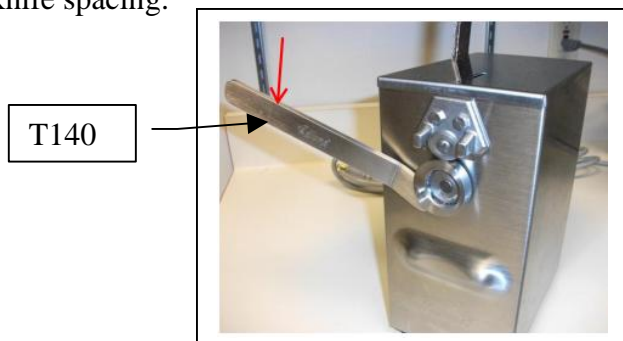

**Caution: Thin spacers washers (W034, W140, W141) are often used to control the gap or spacing between the knife and the gear. Inspect the worn gear when removed to be sure spacer washers are not stuck to the gear. If they are present clean them and return them to the output shaft behind the gear.**

If for any reason the can opener does not function properly, consult the troubleshooting guide for assistance or contact an authorized service agent. Do not operate damaged can openers.

**A qualified technician should do all internal repairs.**

<b>Problem</b>	<b>Cause</b>	<b>Correction</b>
I. Can opener will not start.	1. Cordset not plugged into outlet.	1. Plug cordset into grounded outlet with same voltage as listed on rating label located on back of opener.
	2. Circuit breaker tripped	2. Reset breaker, if breaker continues to trip, replace breaker (A640).
	3. Inoperative actuating switch	3. Replace switch (S229).
	4. Motor may have failed.	4. Check motor and replace as necessary with <b>appropriate voltage</b> motor/geartrain.
	5. Broken wires or loose terminals.	5. Check wiring for continuity and repair or replace as required.
	6. Broken two speed switch (Model 203 only)	6. Replace switch assembly and diode pak. (A2813P, A586)
	7. Cordset has broken wire.	7. Check for continuity and replace as required.
II. Can opener rejects cans.	1. Clearance between back of knife and front of gear too large (see sketch.)	1. With handle in locked-down position check clearance between back of knife and front of gear using flat feeler gauge. Clearance should be 0.001-0.005. Shim gear with W034, W140, or W141 washer to obtain clearance. Use Edlund Tool T140 to remove knife gear.
	2. Motor actuates too soon.	2. Screw down on S086 adjusting screw until motor comes on when bottom of knife is at top of gear teeth to half way down teeth of gear (G006).
	3. Knifeholder is sticking.	3. If knifeholder does not move all the way down, switch will come on too soon. Remove and clean knifeholder and mounting surface. Lubricate with non-sticking vegetable oil.
	4. Knife not rotating.	4. Remove knife and knife stud, clean and lubricate using non-sticking vegetable oil. Replace knife and knife stud. Knife must rotate freely.

III. Drive gear will not turn can.	1. Worn drive gear.	1. Replace gear (G006). Use Edlund Tool (T140) to remove knife gear.
	2. Clearance between top of drive gear and radius at back of knife larger than 0.120.	2. Check clearance. If clearance is larger than 0.120 replace knifeholder (H072) and check clearance. If clearance still too large, check linkage assembly. Assembly (A580DC) may be worn.
	3. Bent knife stud.	3. Replace stud (S196).
	4. Worn knife stud hole in knife holder.	4. Replace knifeholder (H072).
	5. Gear in gear train broken loose from pinion.	5. If motor runs but output shaft doesn't rotate, replace as motor/gear train as necessary <b>PER VOLTAGE</b> .
	6. Threaded hole in spring block (B057) distorted.	6. If linkage assembly not worn, check for distorted hole in spring block.
	7. Worn can stop on knifeholder.	7. Replace knifeholder (H072).
IV. Slivers found on can lid or in food product.	1. Factory knife edge altered or nicked.	1. Replace knife (K006).
	2. Knife doesn't rotate.	2. Remove knife from knifeholder, clean knife, knife stud and knife mounting surface. Lubricate with non-sticking vegetable oil. If knife still doesn't turn, replace knifeholder (H072).
	3. Burred edge on knifeholder can stop.	3. Check knifeholder for burred edge or grooves on can stop. Replace as required.
	4. Drive gear is slipping or milling (removing metal from can bead).	4. See Problem III-2.
V. Knife will not sever lid completely.	1. Dull knife.	1. Replace knife (K006).
VI. Cans will not fit under knife when can opener is off.	1. Worn foot pads.	1. Replace as necessary (P001).
	2. Broken or weak return spring	2. Check return spring (S166), and replace as required.

203/266 Electric Can Opener—Exploded View—(115 V)

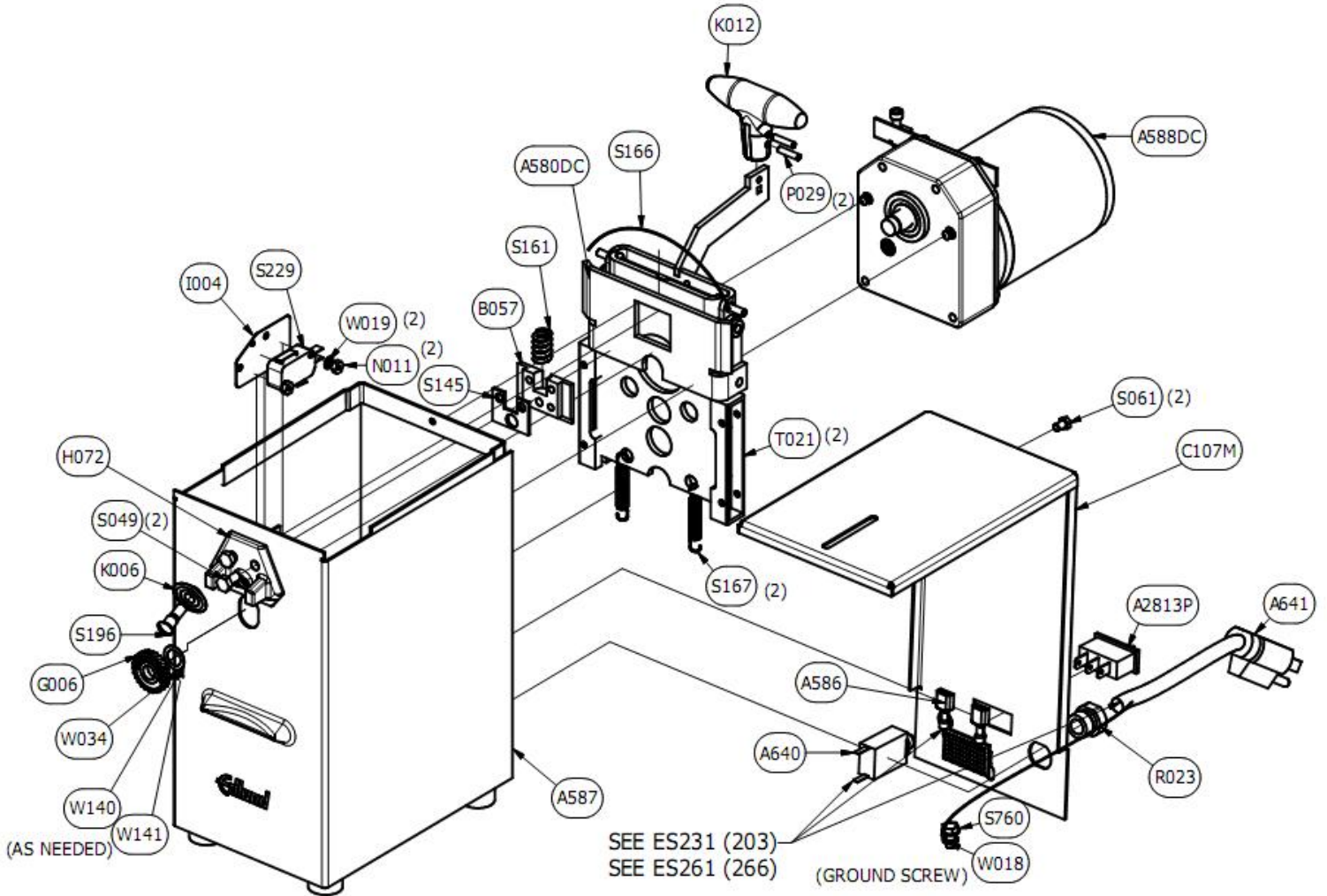

<b>203/266 ASSEMBLY AND PARTS LIST--115V</b>		
<b>QTY</b>	<b>PART NUMBER</b>	<b>DESCRIPTION</b>
1	A2813P	ASSEMBLY, SWITCH, HI/LOW--203 ONLY
1	A580DC	ASSEMBLY, LINKAGE, ENGAGEMENT
1	A586	ASSEMBLY, SPEED CONTROL DIODES--203 ONLY
1	A587	WELDMENT, BASE/CHANNEL
1	A588DC	ASSEMBLY, MOTOR/GEAR TRAIN, 115V
1	A640	ASSEMBLY, WIRING HARNESS FOR CIRCUIT BREAKER
1	A641	ASSEMBLY, CORD, 115V
1	B057	BLOCK, SPRING
1	B410	BREAKER, THERMAL, 1.2 A
1	C107M	COVER, OUTSIDE, 203
1	C108M	COVER, OUTSIDE, 266
1	G006	GEAR, DRIVE, ECO
1	H072	KNIFE HOLDER, SS
1	I004	INSULATOR, SWITCH PAD
1	K006	KNIFE, ECO
1	K012	KNOB, HANDLE
2	N011	NUT, #4-40 BRASS
2	P029	ROLL PIN, 1/8 X 9/16 SS (18-8)
1	R023	STRAIN RELIEF, ELECTRIC CORD
2	S049	SCREW, #10-32 X 3/8, SS HEX HEAD
2	S061	SCREW, #8-32 X .25 HEX HEAD, SS
1	S145	SPACER, KNIFE HOLDER
1	S161	SPRING, KNIFE BLOCK
1	S166	SPRING, ENGAGEMENT RETURN
2	S167	SPRING, TENSION
1	S196	STUD, ECO KNIFE
1	S229	SWITCH, LEAF
1	S760	SCREW, #10-32 X 3/8 SS HEX HD INDENTED HEX
2	T021	TRACK, SLIDE
1	W018	WASHER, #10 LOCK, PLATED
2	W019	WASHER, #4 INTRL TOOTH LOCK, SS
1	W034	WASHER, DRIVE GEAR SPACER. 0.010 THICK
1	W140	WASHER, DRIVE GEAR SPACER, 0.005--AS NEEDED
1	W141	WASHER, DRIVE GEAR SPACER, 0.003--AS NEEDED

203/266 Electric Can Opener—Exploded View—(230 V)

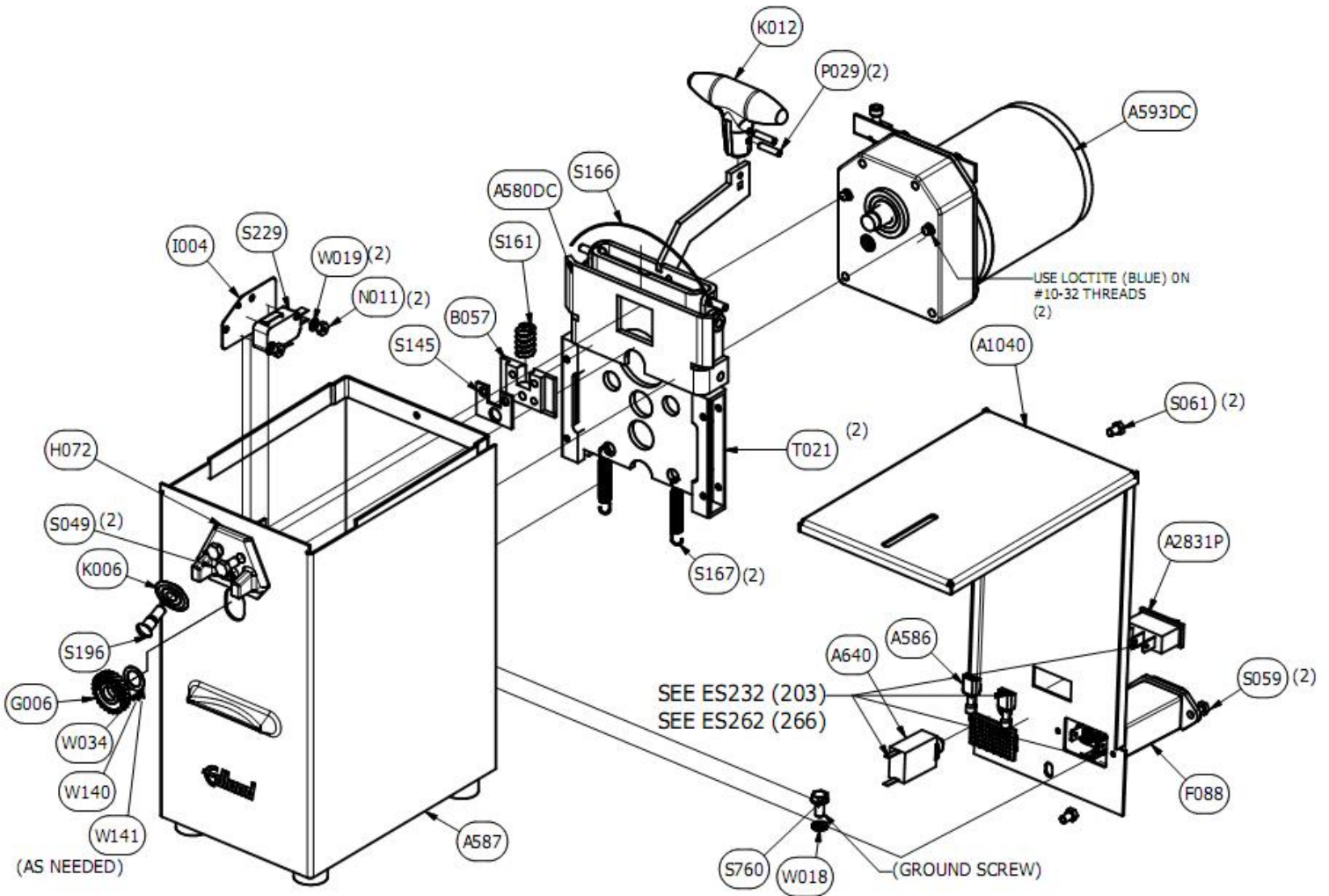



203/266 ASSEMBLY AND PARTS LIST --230V		
QTY	PART NUMBER	DESCRIPTION
1	A1040	COVER, OUTSIDE, 203, 230V
1	A1045	COVER, OUTSIDE, 266, 230V
1	A2831P	ASSEMBLY, HIGH/LOW SWITCH--203 ONLY
1	A580DC	ASSEMBLY, LINKAGE, ENGAGEMENT
1	A586	ASSEMBLY, SPEED CONTROL DIODES
1	A587	WELDMENT, BASE/CHANNEL
1	A593DC	ASSEMBLY, MOTOR/GEAR TRAIN, 230V
1	A640	ASSEMBLY, WIRING HARNESS FOR CIRCUIT BREAKER
1	B057	BLOCK, SPRING
1	B410	BREAKER, THERMAL, 1.2 A
1	F088	FILTER, EMI
1	G006	GEAR, DRIVE, ECO
1	H072	KNIFE HOLDER, SS
1	I004	INSULATOR, SWITCH PAD
1	K006	KNIFE, ECO
1	K012	KNOB, HANDLE
2	N011	NUT, #4-40 BRASS
2	P029	ROLL PIN, 1/8 X 9/16 SS (18-8)
2	S049	SCREW, #10-32 X 3/8, SS HEX HEAD
2	S059	SCREW, #6-32 X .25 HEX HEAD,SS
2	S061	SCREW, #8-32 X .25 HEX HEAD,SS
1	S145	SPACER, KNIFE HOLDER
1	S161	SPRING, KNIFE BLOCK
1	S166	RETURN SPRING
2	S167	SPRING, TENSION
1	S196	STUD, ECO KNIFE
1	S229	SWITCH, LEAF
1	S760	SCREW, #10-32 X 3/8 SS HEX HD INDENTED HEX
2	T021	TRACK, SLIDE
1	W018	WASHER, #10 LOCK, PLATED
2	W019	WASHER, #4 INTRL TOOTH LOCK, SS
1	W034	WASHER, DRIVE GEAR SPACER--0.010 THICK
1	W140	WASHER, DRIVE GEAR SPACER, 0.005--AS NEEDED
1	W141	WASHER, DRIVE GEAR SPACER, 0.003--AS NEEDED