

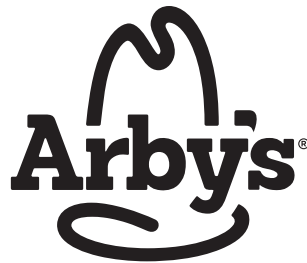

OPERATOR'S MANUAL
with Replacement Parts List



**COMPACT SERIES
SHAKE FREEZER
Model CS704**

185260 - 6/17

**Operator's Manual
for the
Electro Freeze Model CS704
Compact Series Flavor Injected
Shake Freezer**

SAFETY FIRST!

Follow these four steps to safety

1. Recognize Safety Information Look for this safety alert symbol throughout this manual.



When you see this symbol on your freezer or in this manual, be alert to the potential for personal injury. Follow recommended precautions and safe operating practices.

2. Understand Signal Words



The signal words — **DANGER**, **WARNING** and **CAUTION** — are used with the safety alert symbol (DANGER decals on the freezer may or may not have the safety alert symbol, but the message is the same). Decals with the words DANGER, WARNING or CAUTION appear on the freezer. DANGER identifies the most serious hazard. Decals with the words DANGER or WARNING are typically near specific hazards on the freezer. General precautions are listed on CAUTION safety decals. In this manual, CAUTION messages with the safety alert symbol  call attention to safety messages.

3. Follow Safety Instructions

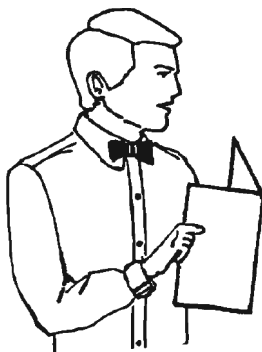

Read and understand all safety messages in this manual. Read and understand the decal safety messages on your freezer. Take notice of the location of all decals on the freezer and keep the safety decals in good condition. Check them periodically and replace missing, damaged or illegible safety decals. The safety decals must remain in place and legible for the life of the freezer. If you need new decals, use the information and illustrations on pages v and vi of this manual to identify the decal and call or write to H.C. Duke & Son, LLC. or local Electro Freeze distributor.

DO NOT attempt to operate the soft serve freezer until you read and understand all safety messages and the operating instructions in this manual.

SAFETY FIRST!

4. Definitions

Trained person (or Operator): A person who has been trained in the basic operation of the freezer. This person is knowledgeable in the operation of machine startup, stopping, filling, and basic cleaning, disassembly, washing, and sanitation of the freezer.

Freezer Technician: A person who has been trained by a factory representative, or an experienced and qualified service person, to perform more complicated operations such as freezer installation, maintenance repairs, component replacement, is aware of hazards associated with electricity, moving parts, and takes necessary steps to protect against injury to themselves and other people.

5. Operate Safely

IMPORTANT: Store Managers, owners, and supervisors must be aware of staff capabilities and that they do not perform freezer operations outside their level of knowledge or responsibility.



DO NOT allow untrained personnel to maintain or service this freezer. Failure to follow this instruction may result in severe personal injury. **DO NOT** operate the freezer until all service and access covers are secured with screws. **DO NOT** attempt to repair the freezer until the main power supply has been disconnected. Some freezers have more than one disconnect switch. Contact your authorized service representative for original equipment parts.

6. Caution



• This Freezer is to be operated by trained persons. The Dispense feature, if used by public in self-serve applications, shall be monitored by trained persons able to assist people with physical, sensory or mental impaired capabilities.

- Children should not be allowed to play around this equipment.
- Do not store explosive substances such as aerosol cans with a flammable propellant in freezer.
- This appliance is not designed for outdoor weather conditions and shall not be exposed to rain.
- Do not wash machine with power sprayer. Do not install machine next to a power sprayer where splash of freezer can occur.
- Machine is designed for use in areas of normal atmosphere. It is not to be used in areas subject to explosion-proof standards.

Safety Decal Locations

Do not attempt to operate the freezer until all safety precautions and operating instructions in this manual are read and understood.

Take notice of all warning, caution, instruction and information decals (or labels) on the freezer as shown in the figure on the following page. The labels have been put there to help maintain a safe working environment.

The labels have been designed to withstand washing and cleaning. All labels must remain legible for the life of the freezer. Check labels periodically to be sure they can be recognized as warning labels.

If it is necessary to replace *any* label, please contact your local authorized Electro Freeze Distributor or H. C. Duke & Son, LLC. When ready to order you will need to determine the (1) part number, (2) type of label, (3) location of label, and (4) quantity required, and include a return shipping address.

You may contact your local authorized Electro Freeze Distributor, as follows:

Name: _____

Address: _____

Phone: _____

or—for factory service assistance—
contact H. C. Duke & Son, LLC. *Electro Freeze* Service Department by phone or FAX:



Phone: 309-755-4553

800-755-4545

FAX: 309-755-9858

E-mail: service@hcduke.com

(The decals on the next page are numbered 1 and 2. Those numbers correspond to the numbers in the table below. The table provides the part number, description, and quantity for each decal.)

No.	Part No.	Description (Qty)
1	HC165126	Decal — Panel Removal Warning (3)
2	HC165025	Decal — Beater Warning (1)

Safety Decal Locations

1 P/N HC165126

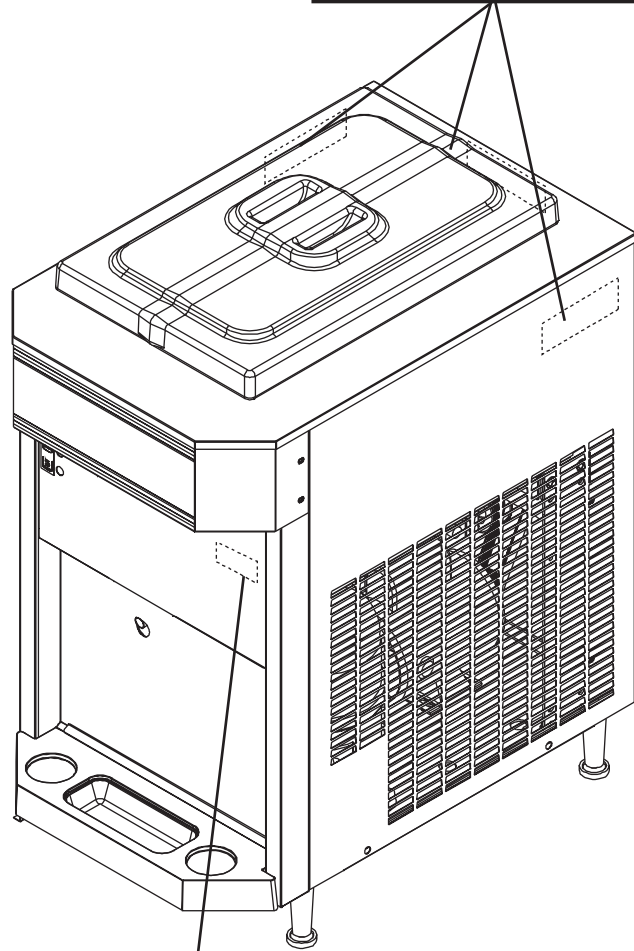
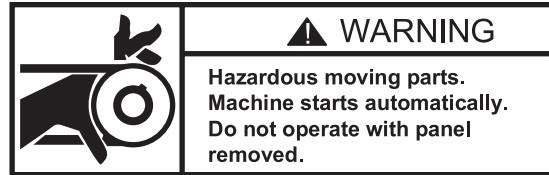

M01830

2 P/N HC165025

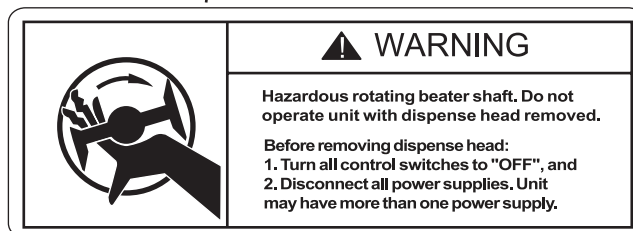

Table of Contents

SECTION	DESCRIPTION	PAGE
	SAFETY	ii
	SAFETY DECALS LOCATIONS	iv
PART I		
1.	INTRODUCTION	1
2.	NOTE TO INSTALLER	1
	2.1. Uncrating and Inspection	2
	2.2. Installation	2
	2.3. Electrical Connections	3
3.	SPECIFICATIONS	3
	3.1 Particulars.....	3
	3.2 Data Plate.....	4
	3.3 Reference Information	4
	3.4 Installation Date	4
	3.5 Dimensions.....	5
4.	PART NAMES AND FUNCTIONS	6
5.	OPERATOR CONTROLS & INDICATORS	10
	5.1 Rinse Switch	11
	5.2 Spinner Motor Fuse	11
	5.3 Lexible Spinner Shaft.....	11
	5.4 Reset -Circuit Breaker	11
	5.5 Selector Switch	11
	5.6 Prime / Calibrate.....	12
	5.7 Flavor Selection Buttons.....	12
	5.8 Indicator Light “ADD MIX”	12
	5.9 Mix Float.....	12
6.	DISASSEMBLY AND CLEANING	13
	6.1 Accessories	13
	6.2 Disassembly Instructions.....	14
	6.3 Cleaning Instructions	17
7.	ASSEMBLY	19

Table of Contents - continued

SECTION	DESCRIPTION	PAGE
8.	START-UP INSTRUCTIONS	23
	8.1 Sanitizing	23
	8.2 Priming	24
	8.3 Dispensing Milk Shakes	25
9.	DAILY PROCEDURES	26
	9.1 Night or Idle Operation.....	26
	9.1.1 General Cleaning	26
	9.1.2 Operation.....	27
	9.2 Draining Product From Freezer	28
10.	PRODUCT INFORMATION	29
	10.1 Overrun.....	29
	10.2 Rerun	29
11.	SYRUP FLAVOR SYSTEM	30
	11.1 Syrup Line Disassembly and Sanitizing.....	30
	11.2 Syrup Line Assembly and Sanitizing	32
	11.3 Syrup Calibration.....	34
12.	ROUTINE MAINTENANCE	35
13.	TROUBLESHOOTING TABLES	39

1 Introduction

This freezer is designed to produce four flavors of milkshakes plus vanilla, with a temperature range of 24° to 30°F (-4° to -1°C). If such products are prepared from powdered concentrate, they should be precooled to 38°F (3°C) prior to introduction to the freezer. Syrups should be free of pulp, seeds or matter that could clog injection ports. Use of other products in this machine is considered misuse (see Warranty).

This manual has been prepared to assist you in the proper operation and general maintenance of the Electro Freeze Model CS704 Freezer.

Your freezer will not compensate for or correct any assembly or priming errors made during the initial start-up. Therefore, it is important to follow the assembly and priming procedures detailed in this manual.

Make sure all personnel responsible for equipment operation completely read and understand this manual before operating the freezer. When properly operated and maintained, the freezer will produce a consistent quality product.

If you require technical assistance, please contact your local authorized *Electro Freeze* Distributor, as follows:

Name: _____

Address: _____

Phone: _____

For factory service assistance—contact H. C. Duke & Son, LLC, *Electro Freeze* Service Department as follows.



Phone: (309) 755-4553
(800) 755-4545

FAX: (309) 755-9858

E-mail: service@electrofreeze.com

2 Note to Installer

This freezer must be installed and serviced by an *Electro Freeze* Distributor or authorized service technician in accordance with the installation instructions.

After installation, the warranty registration card must be completed and returned to validate the warranty.

2.1 Uncrating and Inspection

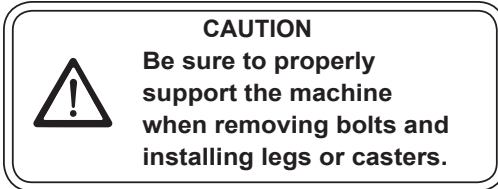

When the unit is received and while the carrier is still present, inspect the shipping carton for any damage that may have occurred in transit. If the SHOCKWATCH® label indicates red and/or the carton is broken, torn, or punctured note the damage on the carrier's freight bill and notify the carrier's local agent immediately. Also note on the freight bill.

1. Remove the carton from the pallet, and move the machine as close as possible to the permanent location.
2. Remove the shipping bolts on the bottom of the freezer and remove the freezer from the pallet.

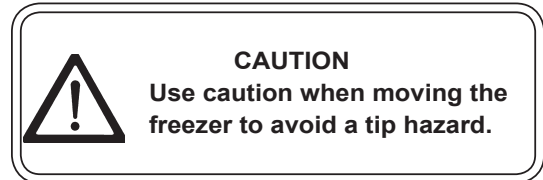

2.2 Installation

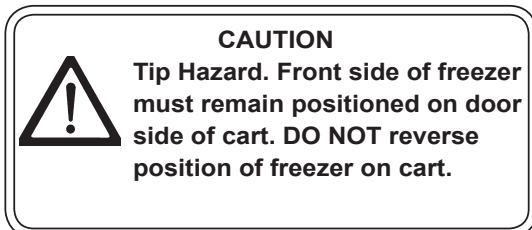
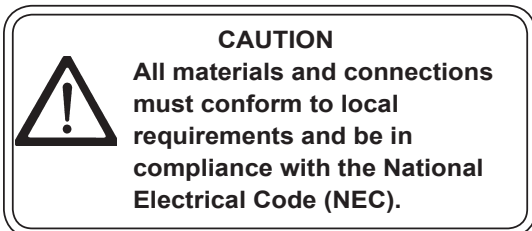

1. This freezer is designed for indoor use and must be protected from outdoor weather conditions.
2. This freezer requires a potable water connection for the rinse line. The water inlet is located at the back of the freezer next to the power supply. A 3/8" MPT water inlet connector will be needed.

3. A minimum 3-inch (7.6 cm) air space is required on both sides and back of the freezer for adequate ventilation.
4. Test the operation of the head and flex shaft cover safety switches prior to placing the freezer in service. See Section 12, Routine Maintenance, Monthly.

2.3 Electrical Connections



CAUTION
All materials and connections must conform to local requirements and be in compliance with the National Electric Code (NEC).



CAUTION
To prevent accidental electrical shock, a receptacle with a positive earth ground is required.

1. Always verify electrical specifications on the data plate (figure 3-2) of each individual freezer. Data plate specifications will always supersede the information in this manual.

2. This freezer requires a protected 20 amp 230 volt circuit. Connect the freezer to a circuit separate from any other electrical equipment. The power cord on this freezer connects to a NEMA 6-20R receptacle. See Figure 2-1.

3. Supply voltage must be within $\pm 10\%$ of voltage indicated on the nameplate. Request your local power company to correct any voltage problem.

4. The control transformer in the electrical box is factory wired to 208 volts (red) wire tap for 208V nominal power supply. If power supply is between 230-240 volts use 240V (orange) wire tap on transformer.

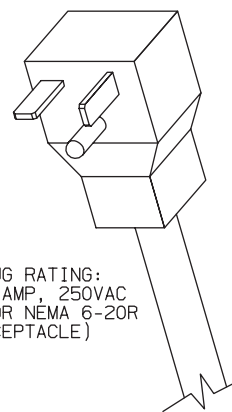

PLUG RATING:
20 AMP, 250VAC
(FOR NEMA 6-20R
RECEPTACLE)

Figure 2-1

3 Specifications

3.1 Particulars

Width (in/cm)	18.4/46.7	Beater Motor	1/2 HP/.37 kw
Height (in/cm)	58.9/149.7	Refrigerant	R-404a
Depth (in/cm)	28.1/71.4	Charge	32.0 oz/.91 kg
Weight (lbs/kg)	250/113.4	Cooling	Air
Voltage*	208-230/60/1	Hopper	20 qts/18.8 liters
Min. Circuit Ampacity	20.0	Cylinder	7 qts/7.1 liters
Compressor	1 HP/8000 (BTUH) .75 kw (Motor) 2.3 kw (Cooling)		

*Contact factory for other voltages.

3.2 Data Plate

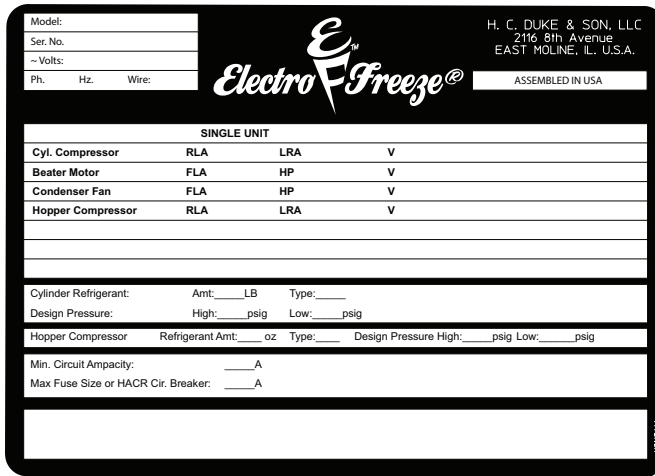

The data plate provides important information that the operator should record and have available for parts ordering, warranty inquiries and service requests.

Figure 3-1

3.3 Reference Information

Write in Reference Information HERE!



Fill in the following information as soon as you receive the *Electro Freeze* CS704. (The item numbers —encircled, below— correspond with the call-out numbers in figure 4-1.)

- 1.) Model Number: _____
- 2.) Serial Number: _____
- 3.) Electrical Spec: Voltage _____
Phase _____ Hertz _____
- 4.) Maximum Fuse Size: _____
- 5.) Minimum Circuit Ampacity: _____

3.4 Installation Date

Fill in the date of installation, and the name, address, and phone number of the installer in the space provided below. This information will be needed when ordering parts or service for the CS704 freezer.

Date of installation: _____

Installed by: _____

Address: _____

Phone: _____

3.5 Dimensions

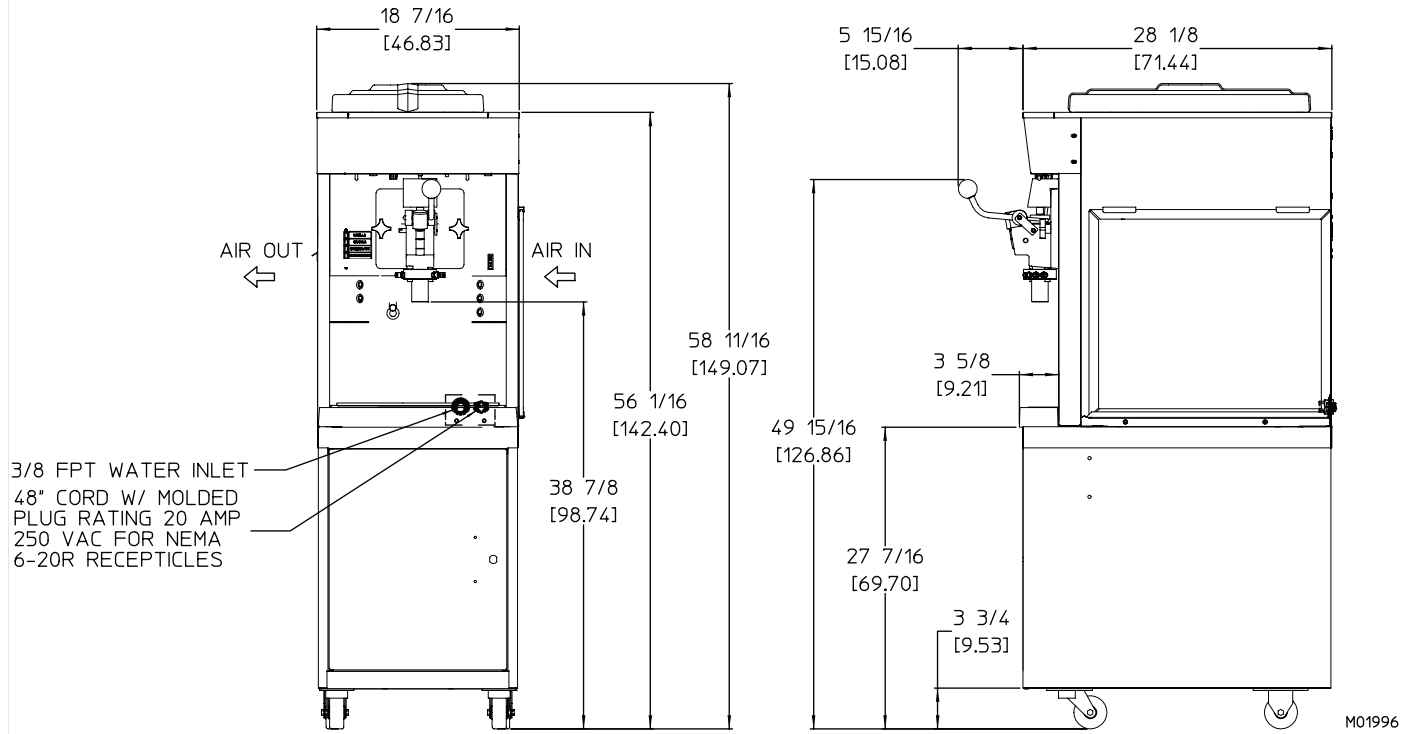

Figure 3-2 Electro Freeze Model CS704 Dimensions

4 Part Names and Functions

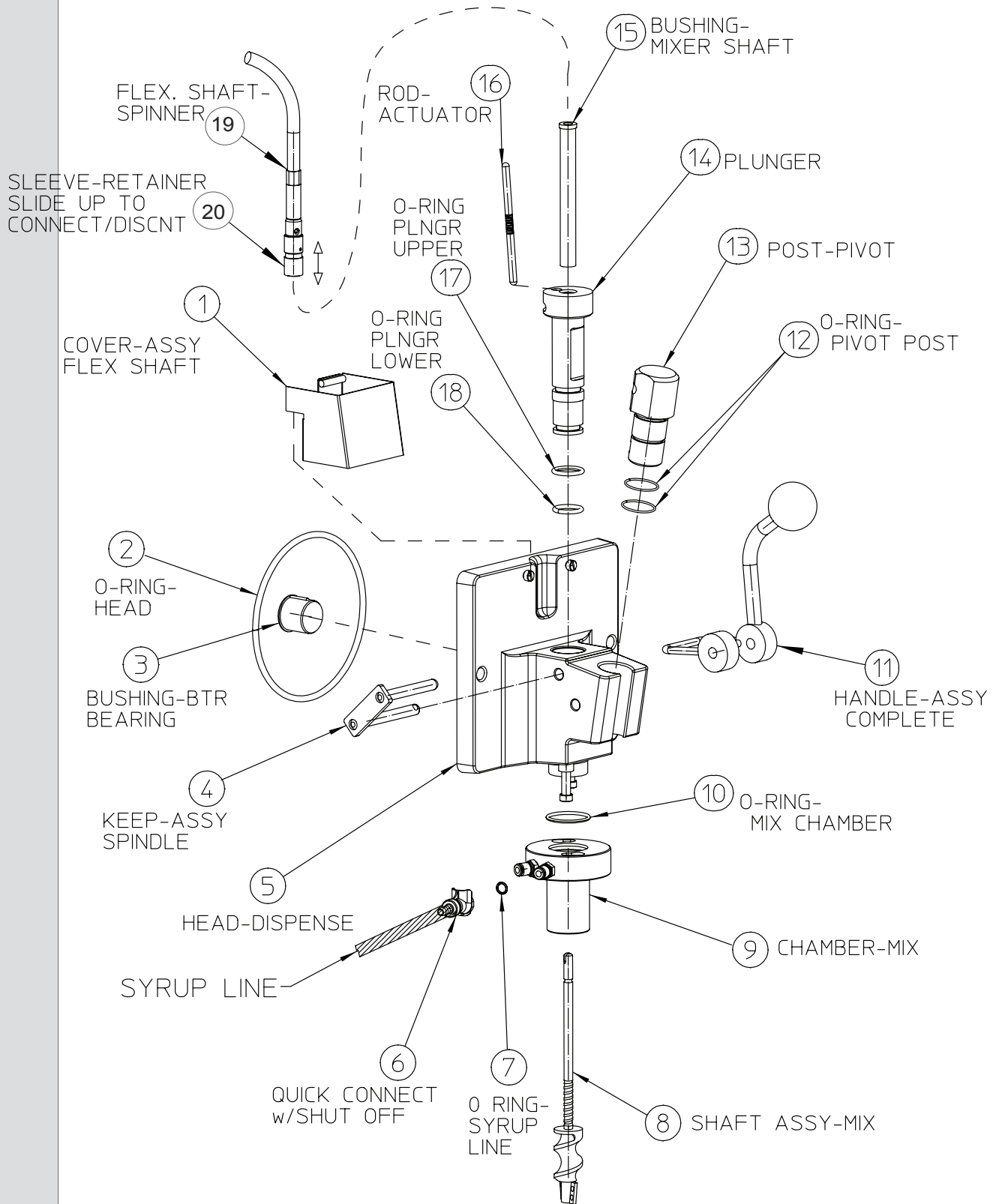

Figure 4-1 Head Assembly

M01997-02

4 Part Names and Functions — continued

The following part names and descriptions refer to figure 4-1.

- | | |
|--|---|
| <p>1.) COVER - ASSY FLEX SHAFT: Protects from accidental contact with rotating shaft. Must be in place to operate.</p> <p>2.) O-RING - HEAD: Seals the head to the freezing cylinder. Must be lubricated.</p> <p>3.) BUSHING - BEATER BEARING: Holds the beater in place at the front of the cylinder. Must be inserted into the head and lubricated before assembly.</p> <p>4.) KEEPER - ASSY SPINDLE: Secures the handle to the head.</p> <p>5.) HEAD - ASSY. W/RETAINERS 4 FLAVOR: Encloses the freezing cylinder and provides an opening for product to be dispensed.</p> <p>6.) QUICK CONNECT WITH SHUT OFF: Allows syrup line to be removed from the mix chamber.</p> <p>7.) O-RING - SYRUP LINE: Prevents syrup from leaking.</p> <p>8.) SHAFT - ASSY MIX: Mixes flavor into shake mix.</p> <p>9.) CHAMBER - MIX: Delivers syrup to the shake mix.</p> <p>10.) O-RING - CHAMBER: Prevents mix from leaking. Lightly lubricate.</p> <p>11.) HANDLE - ASSY COMPLETE: Opens and closes the plunger to start and stop the flow of product from the freezer.</p> <p>12.) O-RING - PIVOT POST: Holds the pivot post in place. Lightly lubricate.</p> <p>13.) POST - PIVOT: Holds the handle in place.</p> <p>14.) PLUNGER - DISPENSING: Seals the product opening in the head when closed. Allows product to flow when open.</p> | <p>15.) BUSHING - MIXER SHAFT: Holds the mixing shaft in place. Prevents wear on plunger.</p> <p>16.) ROD - ACTUATOR: Starts the freezer when dispensing. Must be in place before product can be dispensed.</p> <p>17.) O-RING - PLUNGER-LOWER</p> <p>18.) O-RING - PLUNGER-LOWER: Seals the plunger in the head. Must be lubricated to seal and slide properly.</p> <p>19.) SHAFT - FLEXIBLE W/CASING 16-1/2: Spins the mix shaft.</p> <p>20.) CONNECT - ASSY DRIVE: Quick connector used to connect or disconnect the flexible shaft from the mix shaft</p> |
|--|---|

4. Part Names and Functions — continued

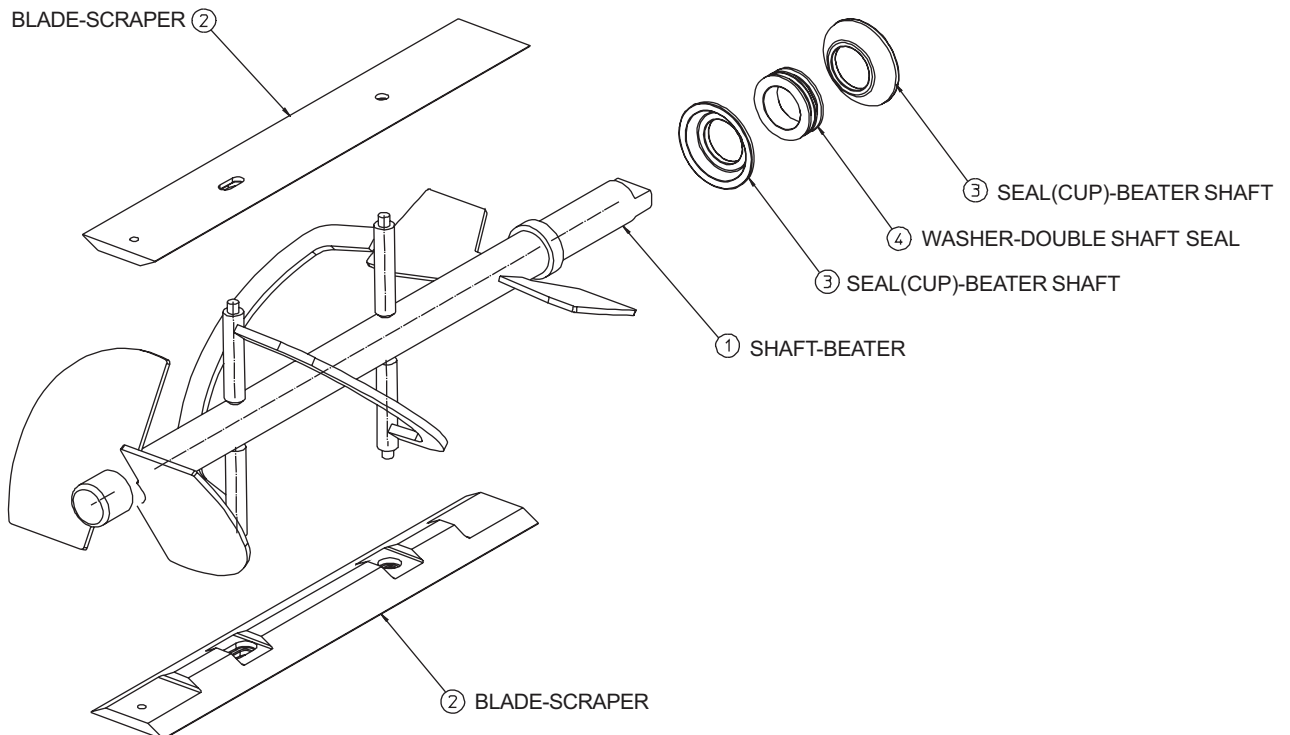
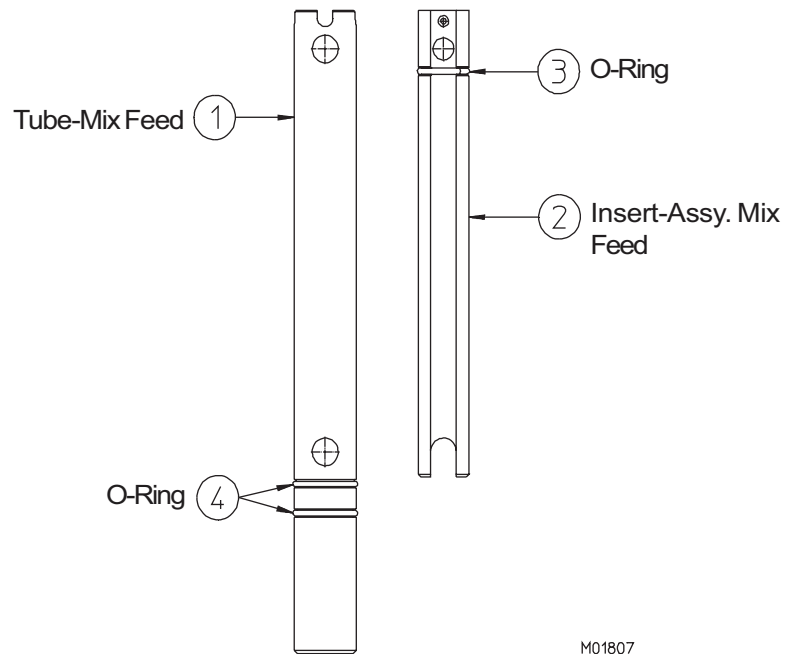

Figure 4-2 Beater Shaft Assembly

The following part names and descriptions refer to figure 4-2.

- 1.) **SHAFT - BEATER:** Rotates in the freezing cylinder, blending air and mix and ejecting product.
- 2.) **BLADE - SCRAPER:** Scrapes the frozen product from the freezing cylinder wall.
- 3.) **SEAL (CUP) - BEATER SHAFT:** Seals the opening between the freezing cylinder and the beater. **DO NOT LUBRICATE.**
- 4.) **WASHER - SHAFT SEAL:** Holds the shaft seals together. Must be lubricated.

4. Part Names and Functions — continued



M01807

Figure 4-3 Mix Feed Tube

The following part names and descriptions refer to figure 4-3.

- 1.) **TUBE - MIX FEED:** Meters the correct amount of mix and air into the freezing cylinder from the hopper.
- 2.) **INSERT - ASSEMBLY MIX FEED (Regulator):** Regulates mix flow. Open position for day operation and closed position for night.
- 3.) **O-RING - INSERT ASSEMBLY:** Holds the insert in place in the mix tube. Must be lubricated.
- 4.) **O-RING - MIX FEED ASSEMBLY:** Seals the opening between the hopper and mix feed tube. O-rings do not need lubrication.

5 Operator Controls

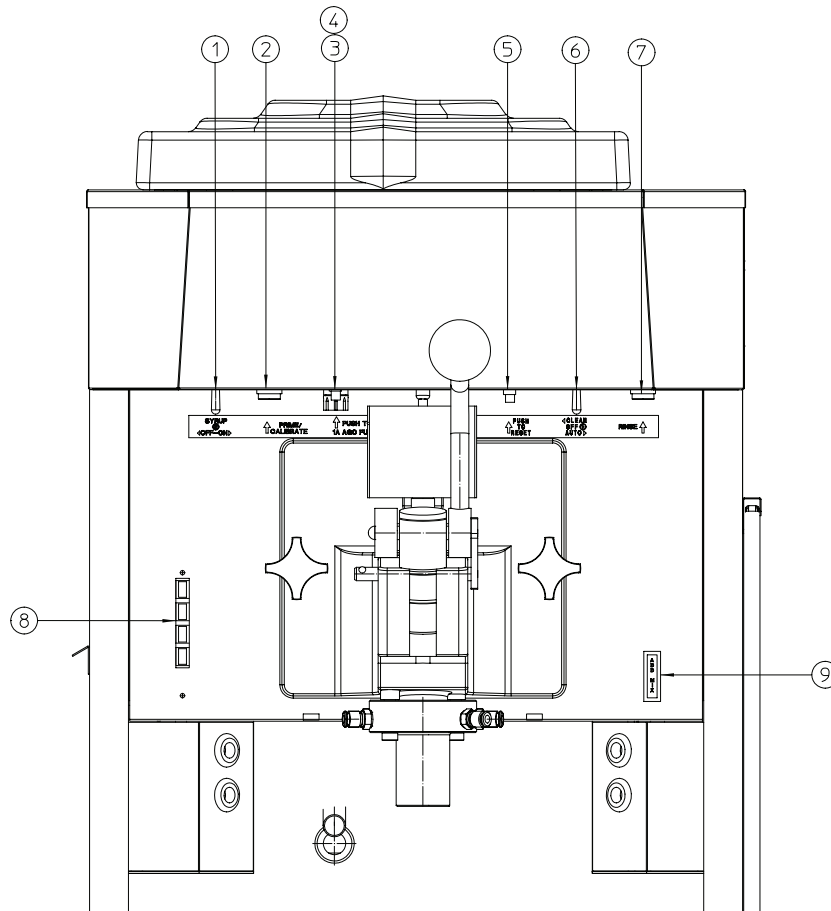

Figure 5-1

M01999-01

The following paragraphs describe the operator controls and indicators. Refer to figure 5-1 for location of these controls and indicators on the freezer.

NOTE: The head, actuator rod, and metal cover must be in place before the beater will operate.



CAUTION
Test operation of the head switch prior to placing the freezer in service. See Section 12, Routine Maintenance, Monthly.

5.1 Syrup Pump Switch (1)

This two-position switch controls the operating mode of your freezer.

- a. **“ON”** (right) — This position operates the syrup motor. Always use this mode when operating the syrup system.
- b. **“OFF”** (left) — In this position the syrup motors do not run.

—continued

5 Operator Controls — continued

5.2 Prime / Calibrate (2)

This push button switch is used for priming and calibrating the flavor syrups. With the syrup switch in the “ON” position, the selector switch (5) in “AUTO” and a flavor selection (8) made, pressing this button will activate the pump for that flavor to flush and prime the flavor delivery line and to allow calibration of the syrup flow.

5.3 Reset - Circuit Breaker Spinner Motor (3)

This control protects the spinner motor against failure from an overload condition by automatically shutting it down. To restart wait 2-3 minutes, then depress the reset button.

Important:
If the circuit breaker trips frequently, your spinner mechanism and circuitry should be checked. Contact your Electro Freeze Distributor.

5.4 Syrup Pump Fuse 4

This holds the AGC fuse for the syrup pumps.

5.5 Reset — Circuit Breaker Beater Motor (5)

This control protects the beater motor against failure from an overload condition by automatically shutting down the freezer. To restart properly, turn the SELECTOR switch (5) to “OFF”, wait 2-3 minutes, then depress the reset button and turn the SELECTOR switchback to the “AUTO” or “CLEAN” position.

Important:
If the circuit breaker trips frequently, your freezer should be checked for proper product temperature, overrun and voltage. Contact your Electro Freeze Distributor.

5.6 Selector Switch (6)

This three-position switch controls the operating mode of your freezer.

a. **“CLEAN”** (left) — This position operates the beater only (no refrigeration). Always use this mode when performing cleaning and sanitizing operations.

b. **“OFF”** (center) — In this position the beater motor and refrigeration system will not operate.

Important:
Do not use the “FREEZE” position with water or sanitizer in the cylinder — the freezer will be damaged.

c. **“AUTO”** (right) — This position activates both the beater motor and refrigeration unit. This is the normal operating position which will maintain a cylinder temperature of 26° to 28°F (-3° to -2°C).

5 Operator Controls — continued

5.7 Rinse Switch (7)

This momentary switch activates the rinse water solenoid valve and the spinner motor to rinse the mixing chamber between flavor changes to eliminate flavor carryover.

5.8 Flavor Selection Buttons (8)

These push buttons are used to select the flavor of shake to be dispensed. Press the button for the desired flavor. Selection of another button will cancel the previous selection. 'Vanilla' provides product from the cylinder only, with no added flavoring. When 'Chocolate', 'Jamocho', or 'Special' are selected, that corresponding pump will operate when product is dispensed.

5.9 Indicator- Light — “ADD MIX” 9

This light indicates the mix in the mix hopper is at a low level and should be refilled as soon as possible. Always maintain *at least 2 inches* (5.1 cm) of mix in the hopper. For best operating results keep hopper full.

5.10 Mix Float (not shown)

When this float is mounted on the float stem inside the hopper it automatically senses the mix level. It activates the “Add Mix” light

6 Disassembly and Cleaning



CAUTION

To avoid electrical shock or contact with moving parts, make sure all switches are in the "OFF" position and that the main power supply is disconnected.

It is important that the freezer be disassembled, washed, lubricated and sanitized before operation.

The cleaning and sanitizing instructions explained in this manual are required to maintain a clean, sanitary freezer. The freezer should be disassembled, cleaned, reassembled, lubricated and sanitized to ensure the best possible product quality and freezer operation.

Persons assembling, cleaning, or sanitizing the freezer must wash and sanitize hands and forearms with an approved sanitizer.

6.1 Cleaning Accessories

The following accessories shipped with the freezer are necessary for cleaning, sanitizing, and disassembly/assembly:

1. BRUSH - HC158010. 6-inch diameter used to clean the cylinder.

2. HANDLE - HC158012. 36-inch handle used with brush p/n HC15010.

3. BRUSH - HC158077. 9/16-inch in diameter with 36-inch handle used to clean drain tube.

4. BRUSH - DOUBLE END - HC158003. 1-1/8-inch diameter and 7/16-inch diameter used for cleaning mix feed tube and general cleaning.

5. TOOL - O-RING REMOVAL. HC169374. Aids in removing O-rings from plunger, head, air relief plug, and spindle.

6. LUBRICANT - COMPOUND 7 (SEVEN) HC158066. Approved lubricant for moving parts, peristaltic tubes and O-rings.

7. BRUSH - HC158026. 1-inch in diameter 12 inches long used to clean the hopper walls.

8. WASH BOTTLE - HC196103. used to flush the plunger and hopper walls.

9. BRUSH - HC158028. 3/8 inch diameter x 1/2-inch 21 inch handle used to clean mix chamber ports and syrup hoses.

9. BEAKER - 150 ML HC196109. Used in syrup calibration. (not shown)

10. KIT - O-RING. Contains all O-rings and seals needing replacement on a regular basis. (not shown)

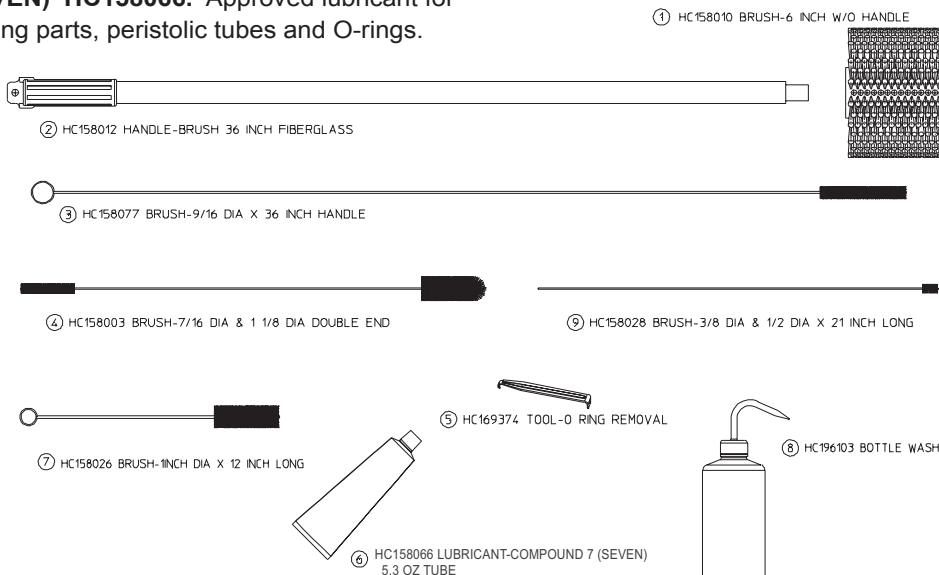
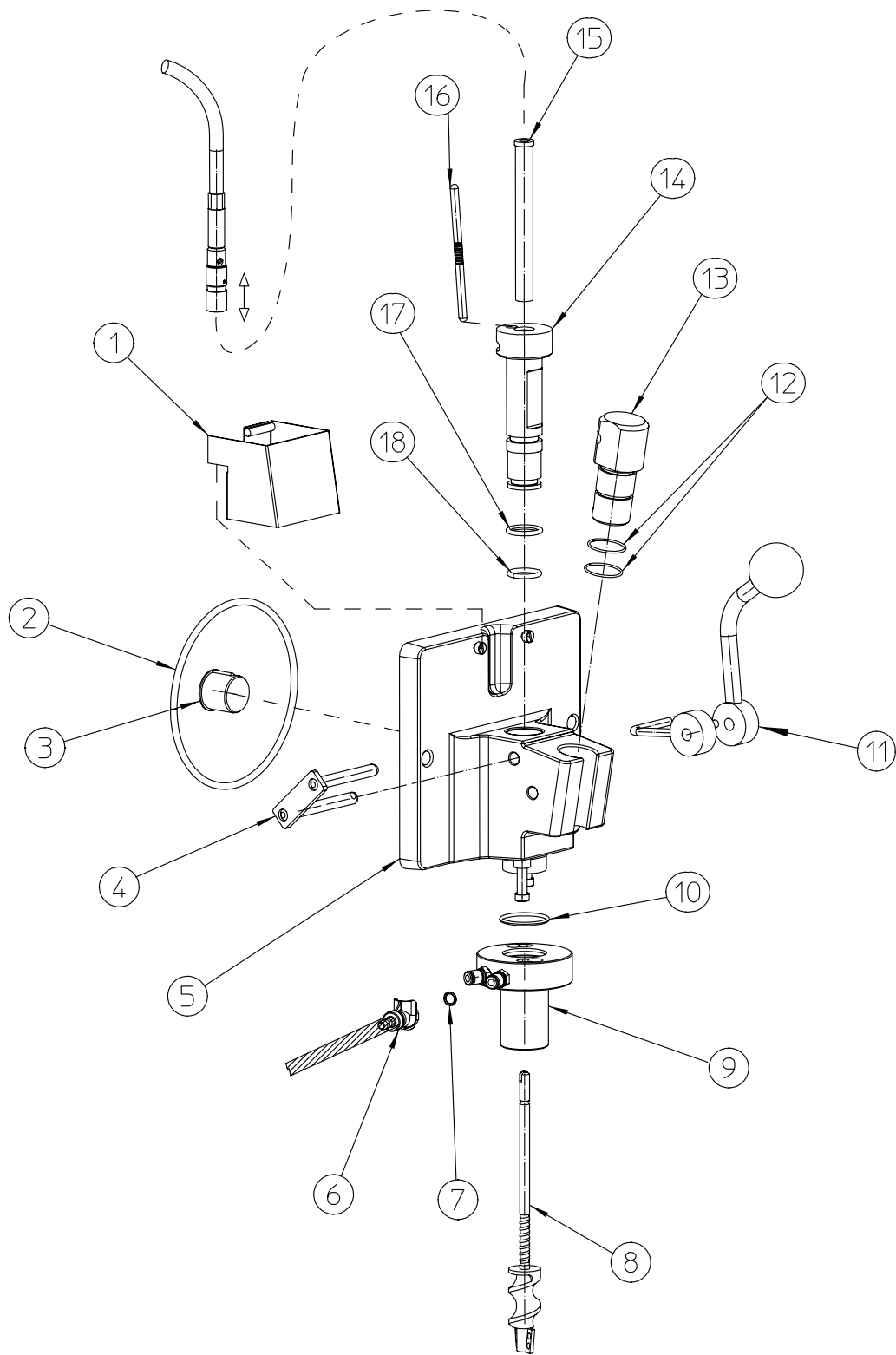

Figure 6-1 Accessories

MO1831-01

6.2 Disassembly Instructions



M01997-02

Figure 6-2 Dispense Head Assembly

6.2 Disassembly Instructions — continued



CAUTION

To avoid electrical shock or contact with moving parts, make sure all switches are in the "OFF" position and that the main power supply is disconnected.



CAUTION

To prevent bacteria growth, remove ALL O-rings when disassembling for cleaning. Failure to do so could create a health hazard.

1. If there is product in the freezer refer to Section 9.2, CLOSING PROCEDURES - DRAINING PRODUCT.
2. Remove flex shaft cover (1). (Refer to figure 6-2).
3. Place an empty bucket under the dispensing head.
4. Remove the syrup lines from the freezer by pressing the metal clip next to the mix chamber. Twist and pull the mix chamber (9) off of the head. Remove the chamber o-ring (10). Remove o-rings (7) from the quick connect fitting on the mix chamber.

5. Remove the actuator rod (16) by lifting up and swing out.

6. Hold onto the bottom of the dispense head (5) and release the mixer shaft (8) from the flexible spinner tube by lifting up the retainer sleeve on the flex shaft.

Important:

Mixing shaft will fall out of the mix chamber and could be damaged if dropped.

FRAGILE. DO NOT DROP.

7. Pull the keeper (4) out of the head. Remove the pivot post (13). Turn the handle (11) and remove from plunger slot.

8. Remove the hand knobs and pull the head straight out.

9. Remove the plunger (14) from the head. Remove the mixer bushing (17) from the plunger.

10. Remove O-rings (2,12,17,18) from the head (5), pivot post (12) and plunger (14).

—continued

6.2 Disassembly Instructions — continued

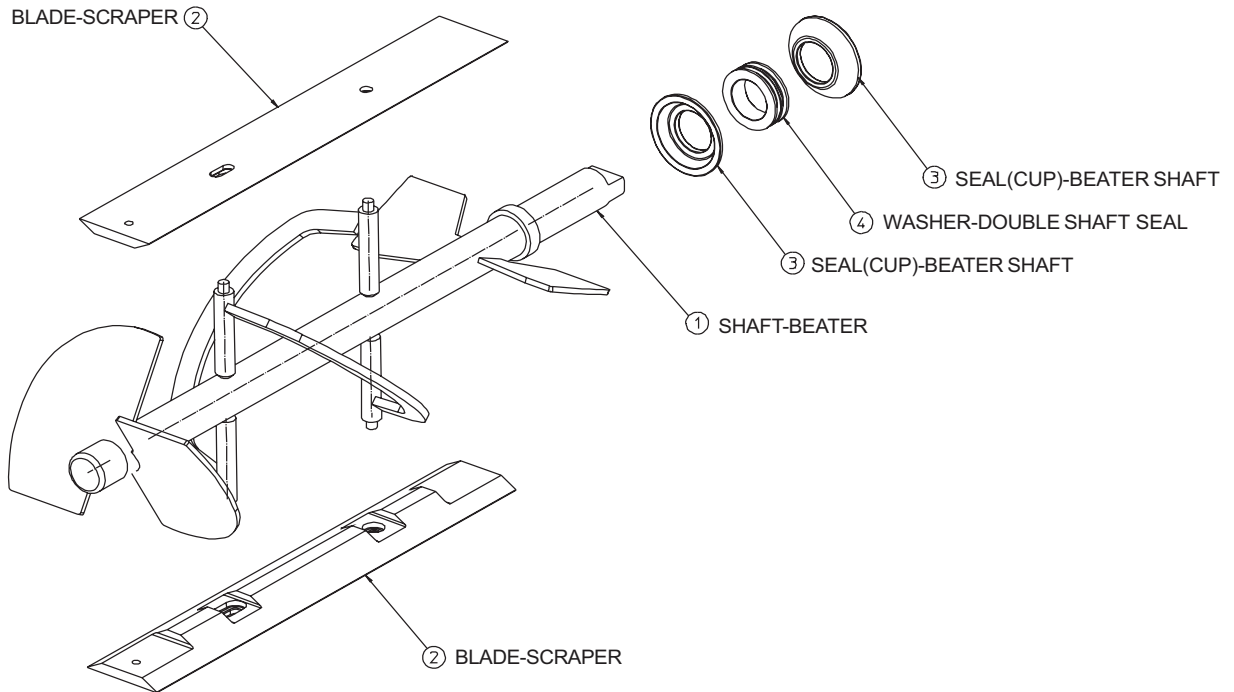

Figure 6-3 Beater Shaft Assembly

11. Remove the beater bearing bushing (figure 6-2, 3) and beater shaft (figure 6-3) from the cylinder. Then remove the scraper blades (2) and shaft seal (3,4) from the beater shaft (1). Remove the cup seals (3) from the washer (4) on the shaft seal assembly . Remove the drip tray.

12. Remove the mix feed tube assembly from the hopper, as shown in figure 6-4 and remove the o-rings (2).

13. Remove the float from the hopper.

14. Wipe off all lubricants with paper towel.

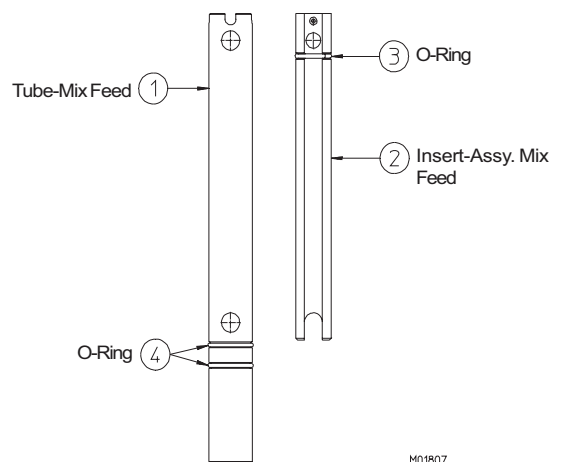

Figure 6-4 Diassemble Mix Feed Tube

6.3 Cleaning Instructions



CAUTION

To prevent bacteria growth, remove all O-rings when cleaning. Failure to do so could create a health hazard.



CAUTION

Electrical shock hazard. Do not splash water on switches or allow water to flow onto electrical components inside the machine.

The cleaning instructions explained in this section are procedures to remove bacteria. The shake freezer must be disassembled, washed, and sanitized according to the instructions in this manual before start-up to ensure the best possible cleanliness.

Important:

Do not use unapproved sanitizer or laundry bleach. These materials may contain high concentrations of chlorine and will chemically attack freezer components.

NOTE: It is your responsibility to be aware of, and conform to, the requirements for meeting federal, state and local laws concerning the frequency of cleaning and sanitizing the freezer.

1. Prepare a three-compartment sink in accordance with local health regulations. The sink will be used to wash, rinse, and sanitize the freezer components which will be removed later. Also, prepare a clean surface to air-dry all parts.

NOTE: The sanitizer should be mixed according to the manufacturer's instructions to yield 100 PPM strength chlorine solution (example: Stera Sheen Green Label®). Use warm water (100° to 110°F or 38° to 43°C) to wash, rinse, and sanitize.

2. Wash all parts removed from the freezer thoroughly with a dish detergent solution. Clean the following parts with the appropriate supplied brush:

- a. The head assembly, o-ring grooves, plunger, key and dispense openings as shown in figure 6-5.
- b. The mix feed tube, insert and o-rings as shown in figure 6-6.

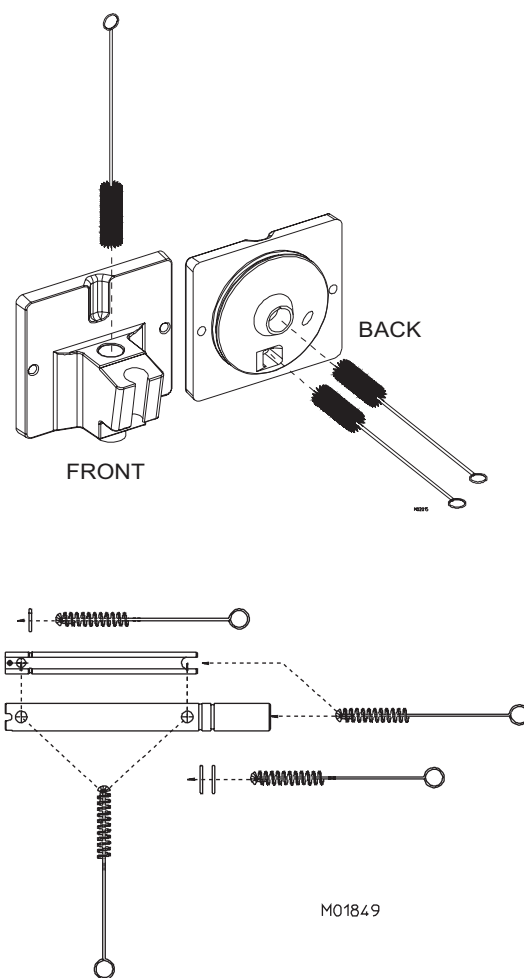

Figure 6-6

—continued

6.3 Cleaning Instructions — continued

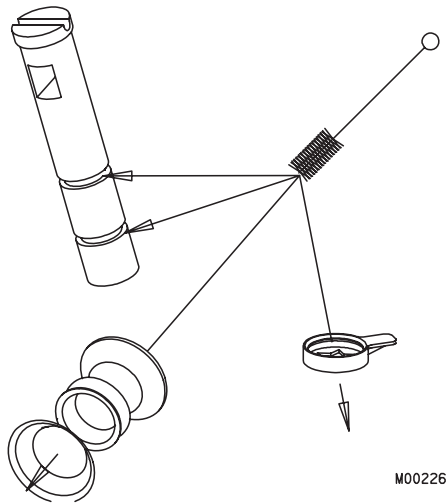

Figure 6-7 Clean shaft seal and plunger

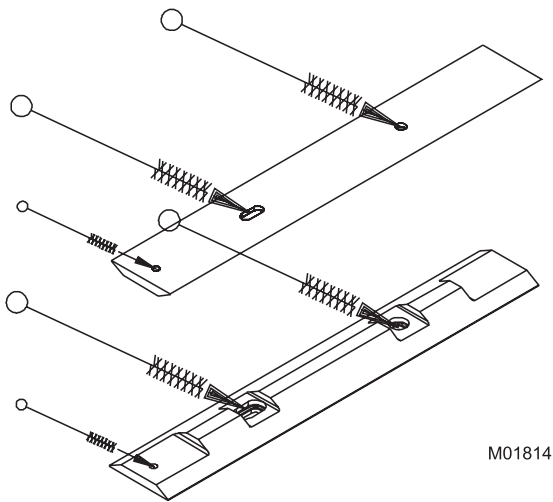

Figure 6-8 Clean scraper blades

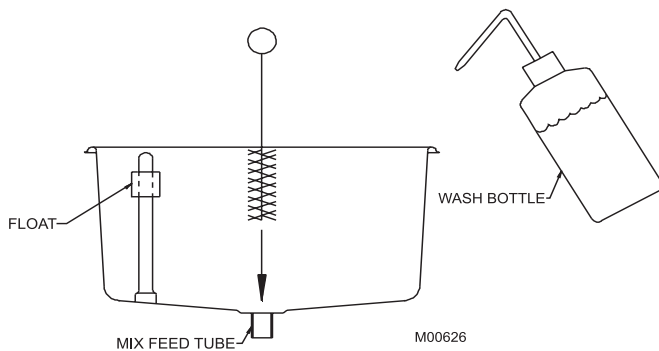

Figure 6-9 Clean hopper and mix feed port

c. The shaft cup seal, washer, and plunger O-ring grooves (figure 6-7).

d. The beater shaft and the scraper blade pin holes, shown in figure 6-8.

e. The mixer shaft and bushing.

g. Mix chamber and tubes.

3. After all parts are washed, rinse and place them in the sanitizing solution. **For proper sanitizing, all parts must remain fully immersed in the sanitizer for 5 minutes.** Allow parts to air-dry after sanitizing.

Important:

Do not leave parts in sanitizer for more than 15 minutes.

4. Wash hopper walls and all soiled surfaces on the freezer with a clean disposable towel.

5. Using the spray bottle filled with sanitizing solution spray out the end of each syrup line and the water line connector.

6. Using proper brush, brush the hopper inlet tube (figure 6-9), the drain tube, the cylinder, and cylinder back wall (figure 6-10), thoroughly with dish detergent solution. Rinse using rinse bottle. Using sanitizing solution, repeat brushing procedure making sure all surfaces contact sanitizer.

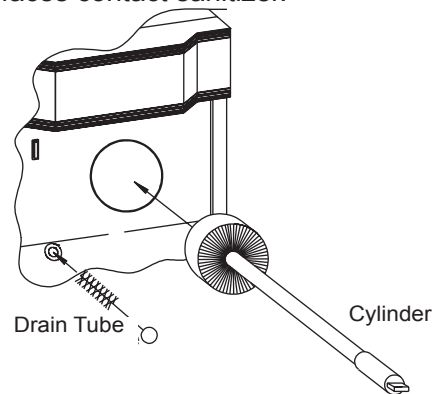

Figure 6-10 Clean drain tube & cylinder

Replace worn brushes. Use only Electro Freeze original or authorized replacement parts. See Accessories Parts List in Part II of this manual to order new brushes.

7 Assembly

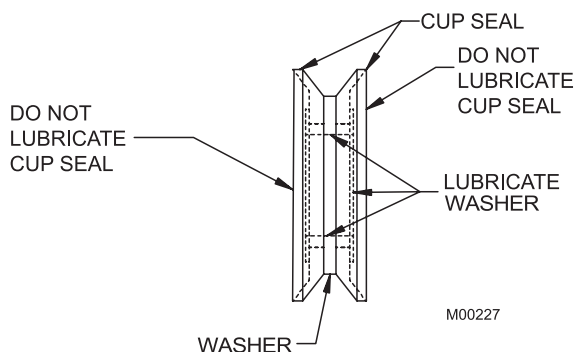

Figure 7-1 Shaft Seal Lubrication

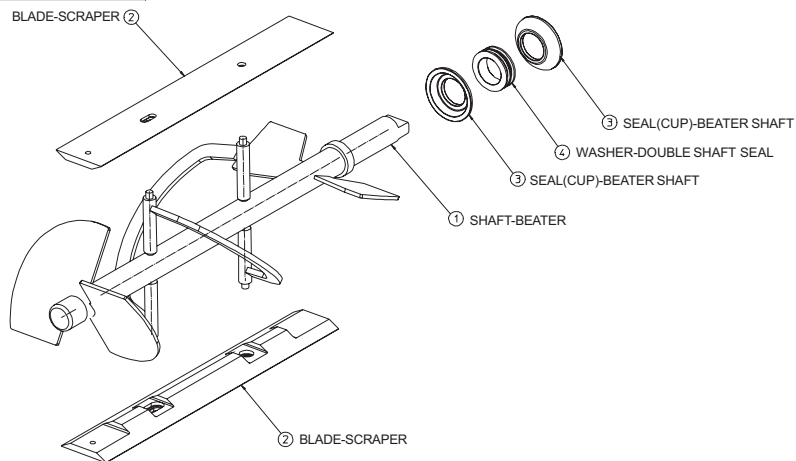

Figure 7-2 Beater Shaft Assembly

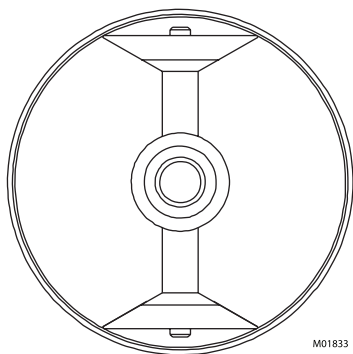

Figure 7-3 Scraper Blade Installation

Correct assembly of the freezer is essential to prevent leakage of the product and damage to the freezer. To assemble the freezer, you will need an approved lubricant (such as Compound 7). Make sure all parts of the assemblies have been washed and sanitized before assembling. Persons assembling the freezer must first wash and sanitize their hands and forearms with an approved sanitizer.

CAUTION



To avoid electrical shock or contact with moving parts, make sure all switches are in the "OFF" position and that the main power supply is disconnected.

1. Persons assembling the freezer must first wash and sanitize their hands and forearms with an approved sanitizer.
2. Assemble the shaft seal by installing the cup seals (3) on the plastic washer (4). Apply a moderate amount of approved sanitary lubricant (such as Compound 7) to the washer. Do not allow any lubricant to come in contact with the bell-shaped rubber portions of the seal (figure 7-1).
3. See figure 7-2. Install the shaft seal over the rear of the beater shaft. Wipe off excess lubricant from the beater shaft.
4. Place the scraper blades on the beater shaft, making sure the blades are installed properly.
5. See figure 7-3. Insert the assembled beater shaft into the cylinder by placing one blade on the bottom of the cylinder. This will center the beater and allow alignment with the drive shaft. Rotate the beater assembly while pushing, until the shank has engaged the drive shaft.

—continued

7 Assembly — continued

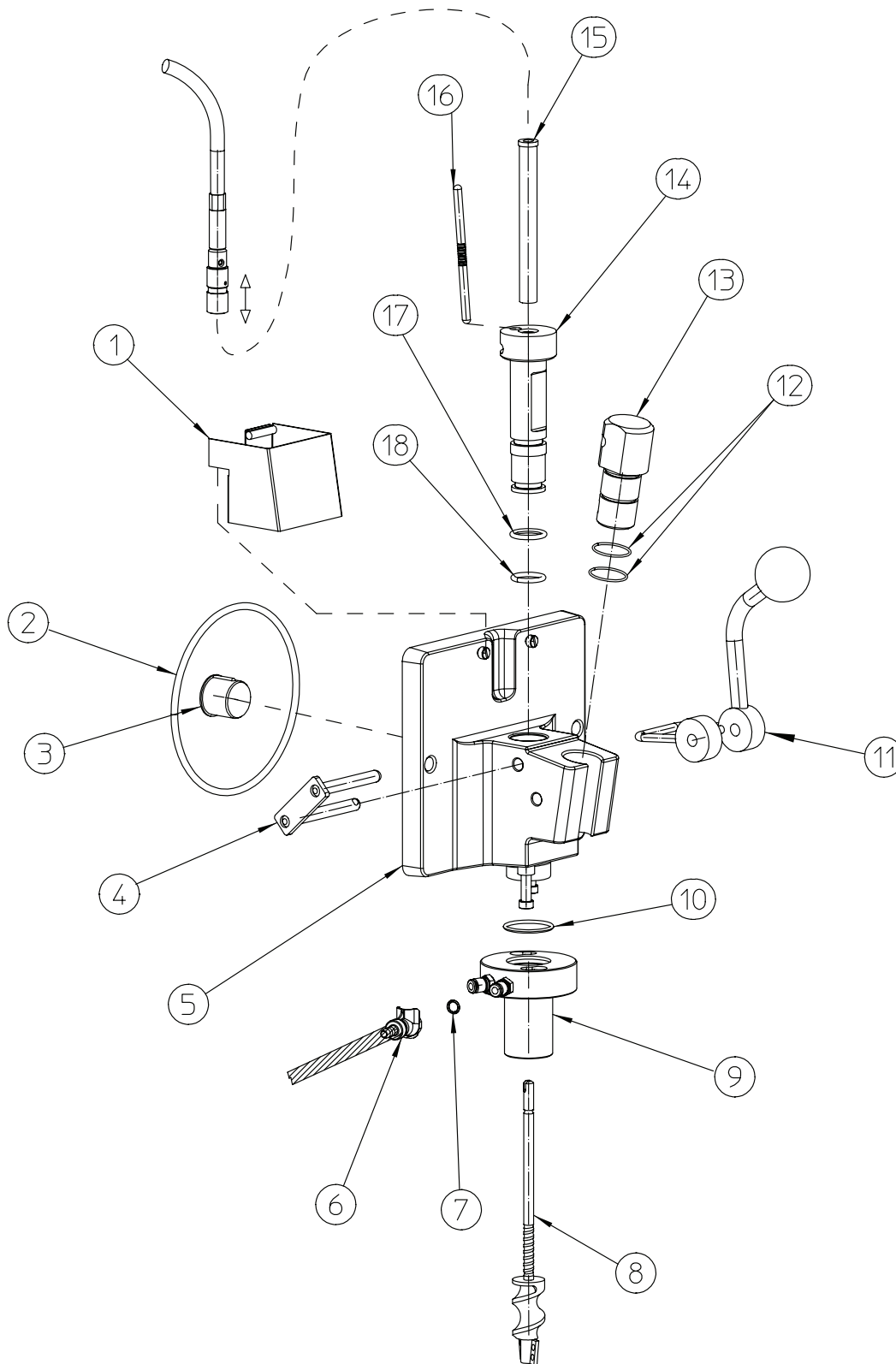

Figure 7-4 Head Assembly

M01997-02

7 Assembly — continued

6. See figure 7-4 and o-ring chart in the replacement parts section of this manual. Install the head o-ring (2) into the groove on the back of the dispense head (5),

7. (Install the o-rings (17, 18) on the plunger (14). Lubricate the o-rings.

8. Install the o-rings (12) onto the pivot post (13). Lubricate o-rings lightly. Insert pivot post into the head so the holes are toward the back.

9. Install the mixer shaft bushing (15) into the plunger (14).

10. Install the plunger (14) into the head (5) just past the top o-ring with the slot facing back. Turn slot slightly to the left and hook handle (11) into the slot. With handle in the slot turn the slot to the back.

11. Place the keeper (4) through the handle (11), pivot post (13) and head (5) until it locks in place.

12. Lubricate the inside surface of the beater bearing bushing (3) and place in the head (5) making sure to align bushing key into head slot, as shown in figure 7-5.

Important:

Match the key on the bushing. Make sure the key aligns with the slot. Failure to install the bushing properly in the dispensing head will damage the head.

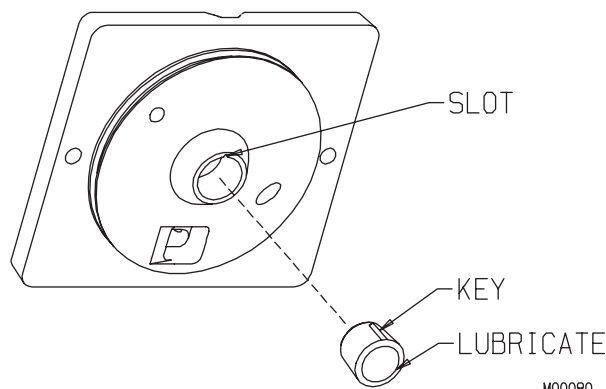

Figure 7-5 Head Bushing

13. Install the dispensing head onto the freezer by tilting the top of the head towards you, aligning the studs with the holes in the head, and sliding toward the freezer. As you push the head towards the freezer, carefully rock it into place, and align the shaft with the drive coupling.

14. Tighten the hand knobs simultaneously, finger-tight only.

Important:

Excessive force will damage the head. Do not use tools to tighten.

15. Insert mixing shaft (8) into the bottom of the head (5) with mixer paddle towards the bottom. Pull back the sleeve on the end of the flexible spinner tube in the switch box and insert mixing shaft into tube, turning until it snaps into place.

16. Install the o-ring (10) by pushing it into groove in the mixing chamber (9). Lightly lubricate the o-ring. Install the mix chamber on to the bottom of the head by placing over bolts and turn to lock in place.

17. Install the actuator rod (16) by placing one end into hole in the bottom of the switch box and the other end in the indent in the plunger behind the flex shaft.

18. Place flex shaft cover (1) on top of head using bolts to lock in place.

Important:

The freezer will not dispense product without the flex shaft cover in place.

19. Install the five o-rings (7) on quick connect fittings (6) on the mix chamber. Lightly lubricate o-rings..

20. Push each syrup line quick connect (6) onto fitting of the mixing chamber (10).

—continued

7 Assembly — continued

21. See Figure 7-6. Install the o-ring (3) on the mix feed insert (2) and lubricate. Then install the o-rings (4) on the mix feed tube (1) lightly lubricate. Place the insert inside the mix feed tube.

22. Lay the mix feed tube assembly in the hopper pan. (Do not install in the mix feed port in the hopper at this time.)

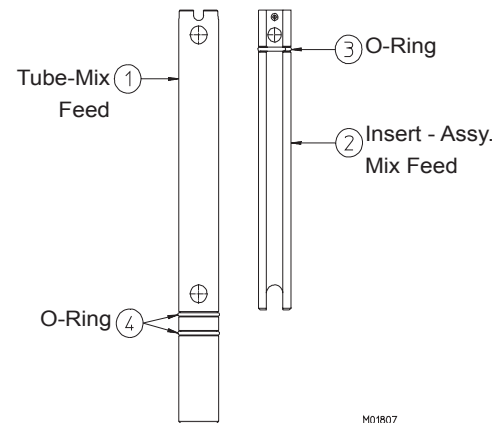



Figure 7-6

8 Start-up Instructions

8.1 Sanitizing

The sanitizing instructions explained in this section are procedures to remove bacteria and maintain a clean, sanitary freezer. The shake freezer must be disassembled, washed, and sanitized according to the instructions in this manual before start-up to insure the best possible cleanliness.

CAUTION



To prevent bacteria growth, use only approved sanitizers to sanitize the freezer. Sanitizing must be done just prior to starting the freezer. Failure to do so could create a health hazard.

Important:
Do not use unapproved sanitizer or laundry bleach. These materials may contain high concentrations of chlorine and will chemically attack freezer components.

NOTE: It is your responsibility to be aware of and conform to the requirements for meeting federal, state and local laws concerning the frequency of cleaning and sanitizing the freezer.

1. Prepare 2 gallons (7.6 liters) of sanitizing solution in a container. Sanitizing solution must be mixed according to manufacturer's instructions to yield 100 PPM strength chlorine solution. (example: Stera-Sheen Green Label). Use warm water (100-110°F or 37-43°C) to wash, rinse, and sanitize.

2. Wash and sanitize your hands and forearms.

3. The mix feed tube assembly should be laying in the bottom of the hopper pan. Do not install.

Important:
Never let the sanitizer remain in the freezer for more than 15 minutes.

Important:
Do not insert any tools or objects into the mix feed port or head dispensing hole while the freezer is running.

4. Pour sanitizing solution into the hopper pan. Using a clean brush, scrub the hopper walls, the mix feed port from the hopper to the cylinder, the inside of the mix feed tube and adapter (see figure 8-1), and the inside of the hopper cover.

5. Insert mix float on mix level sensor.

6. Allow sanitizer to fill the cylinder.

7. Connect the main power supply.

8. The syrup switch should be in the "OFF" position. Place the selector switch to the "CLEAN" position and allow the beater to run for 5 minutes. During this time period check for leaks around the head, plunger and drain tube.

9. Place an empty container under the dispensing head and drain the sanitizing solution from the cylinder by slowly pulling down on the dispense handle. Open and close the handle approximately 10 times during draining to sanitize the port area of the dispense head.

10. With most of the sanitizing solution drained, turn the selector switch to the "OFF" position and drain remaining solution from the hopper and cylinder and close the plunger.

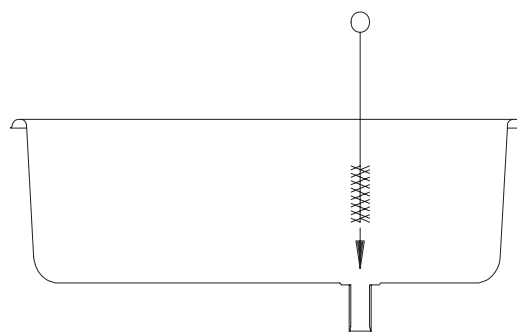

Figure 8-1 Sanitize hopper and its components

8.2 Priming

Priming the freezer removes all excess air and sanitizer from the freezing cylinder and sets the proper overrun for the first cylinder of product. Always have clean, sanitized hands when handling mix feed assemblies. Handle only the top 1". Make sure the mix feet tube assembly and the inside of the hopper cover are cleaned with sanitizer.

1. Wash and sanitize your hands and forearms.
2. Place an empty container under the dispense head. Install the mix feed tube assembly in the closed position, as shown in figure 8-2, into the mix feed drain in the hopper. Pour a minimum of 2-1/2 gallons of mix into the hopper.
3. Hold the plunger open and remove the mix feed tube to allow mix to push out the sanitizer. When pure mix flows from the dispense head close the plunger.
4. When the mix stops bubbling install the mix feed tube into the mix feed hopper drain in the "open" position. Place the selector switch to the "AUTO" position and the syrup switch to the "ON" position.

Important:
Failure to completely remove sanitizer or water from the freezing cylinder before placing in "AUTO" will damage the freezer.

5. Fill the hopper with mix and Install the hopper cover.

6. During long idle periods, the regulator should be closed — **but remember— when dispensing product, ensure that the mix feed regulator is "OPEN" at all times.** If not open, the flow of mix will be restricted. If lubricant blocks the inlet hole in the tube it would also restrict the flow of mix.

Pin is in line with hole.

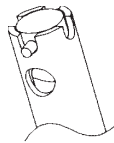

OPEN

Look through top hole in tube — you should see clear through.

Pin is not in line with hole.

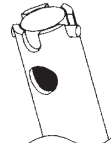

CLOSED

Look through top hole in tube — you should see the inner white plastic insert tube (regulator) blocking the opening.

Figure 8-2 Mix Feed Tube Positions

8.2 Dispensing Milk Shakes



CAUTION

DO NOT touch or get too close to moving parts. Clothing, jewelry, hair or other body parts may become caught in the machine and result in personal injury.

1. Place the syrup pump switch (1) to the "ON" position. See figure 8-3
2. To dispense milk shake select desired flavor (8) on the front panel.
3. Place cup under mixing chamber.
4. Pull down on handle to dispense shake mix and blend in flavoring. Turn cup as shake dispenses.
5. When cup is filled push handle up to stop dispensing and remove cup.
6. Product is ready to serve.
7. To clean mixing chamber before a different flavor is selected, place an empty cup under the mixing chamber and push the rinse button (7) to clean mixing chamber before next serving.

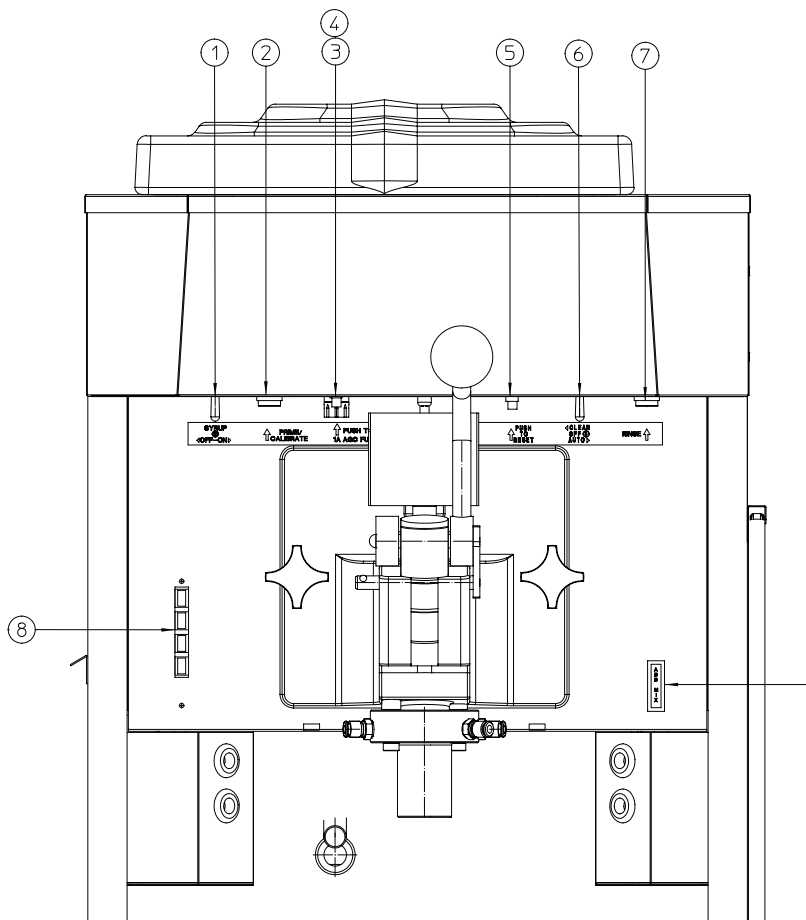

Figure 8-3

9 Daily Procedures

9.1 Night or Idle Operation

9.1.1 General Cleaning

1. Remove the spinner flex shaft cover assembly (1) in preparation to disassemble the shake mix chamber (9).

SAFETY NOTE: Removal of the flex shaft cover disables the spinner motor.

2. Disconnect the syrup lines and water rinse line from the mix chamber.

3. Remove the mix chamber and set aside for cleaning.

4. Disconnect the flex-shaft from the spinner shaft (taking care not to drop the spinner shaft which will fall out of the plunger), remove the spinner shaft from the shake head.

5. Prepare a container of sanitizing solution. Sanitizing solution must be mixed according to manufacturer's instructions to yield 100 PPM strength chlorine solution. (example: Stera-Sheen Green Label). Use warm water (100-110°F or 37-43°C). Fill the wash bottle with sanitizing solution.

6. Using a brush and bottle of sanitizing solution wash down the bottom of the shake head and plunger, being sure to clean the plunger spinner shaft hole with a brush.

7. Using the bottle of sanitizing solution.

a. rinse down the head, end of the plunger, and plunger spinner shaft hole

c. spray out the ends of each syrup line connector. Also spray the end of the connector for the water line.

d. wash the mix chamber using a brush to clean the center bore as well as each of the syrup holes.

e. wash the spinner shaft using a brush to clean the paddle holes.

f. rinse off the cleaned mix chamber and spinner shaft with clean sanitizing solution.

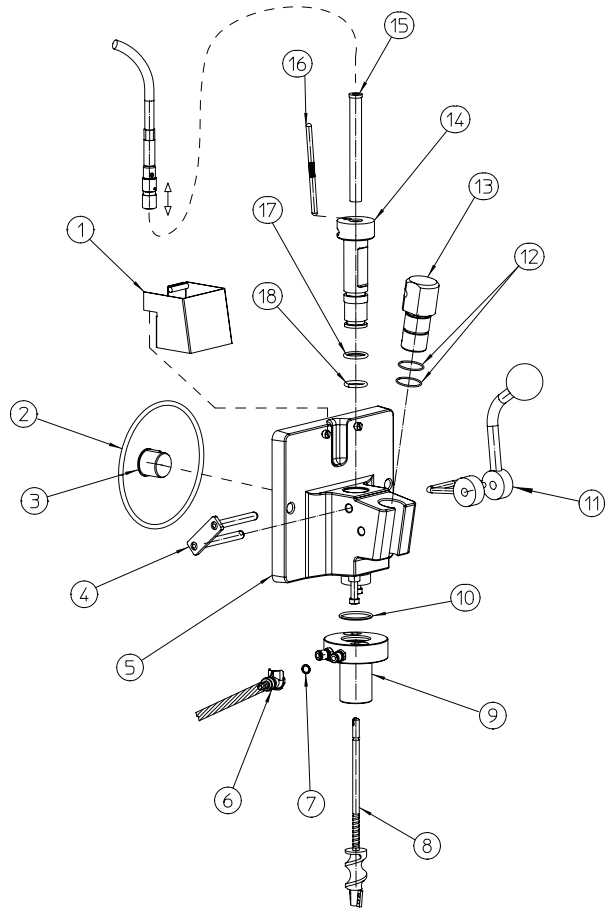

Figure 9-1

8. Set parts aside to dry.

9. Leave shake mix system disassembled overnight and re-assemble prior to the next use. See Assembly Section 7.

10. If your location is open 24 hours, system must be cleaned once a day, we recommend cleaning steps 1 through 11 in the morning or other slow period.

9.1.2 Operation

1. In areas where state and local health codes allow, leave the Selector Switch in the "AUTO" position and the syrup switch to the "OFF" position.

Note: The plunger rod and cover must be in place for the unit to operate.

2. Clean all soiled surfaces with a warm dish detergent solution.

3. Turn the mix feed regulator to the "CLOSED" position as shown in figure 9-2.

4. Check mix level in hopper to ensure that there is enough mix to keep the indicator light off, add mix if necessary. **Do not dispense product when the mix feed regulator is in the "CLOSED" position.**

5. Before serving from the machine use the wash bottle and spray the plunger and mix chamber opening with sanitizing solution and "OPEN" the mix feed regulator and fill the hopper with mix (figure 9-2).

Pin is in line with hole.

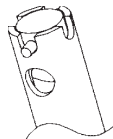

**OPEN
DAY**

Look through top hole in tube — you should see clear through.

Pin is not in line with hole.

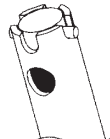

**CLOSED
NIGHT**

Look through top hole in tube — you should see the inner white plastic tube (regulator) blocking the opening.

Figure 9-2 Mix Feed Tube Positions

9.2 Draining Product from Freezer

NOTE: It is your responsibility to be aware of and conform to the requirements for meeting local, state, and federal laws concerning the frequency of cleaning and sanitizing the freezer.

To remove frozen product from the cylinder, perform the following steps:

1. Remove the flex shaft cover.
2. Place the selector switch in the "CLEAN" position.

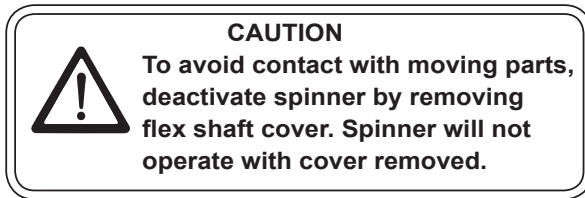

3. Place a clean, sanitized container under the dispensing nozzle on the drip tray.
4. Remove the mix feed tube from the hopper. (See figure 9-3).
5. Disconnect the syrup lines.
6. Twist and pull down the mixing chamber removing it from the head.
7. Disconnect the mixer shaft by releasing the coupling while pulling on the bottom.
8. Take parts to sink.
9. Place a clean, sanitized container under the dispensing nozzle on the drip tray. Dispense the product until the mix is removed. Close the plunger. Place the selector and syrup switches to "OFF" and continue dispensing product until it quits flowing and . If local health codes permit, cover the rerun product container and place it in the cooler. (See 10.2 General Information - Rerun).

10. Pour 2 gallons of cold water into the hopper. Place the selector switch to "CLEAN" and dispense the cold water.

Important:
DO NOT use hot water. Damage to the freezer could occur.

11. Follow with 2 gallons of warm water and repeat until the freezer dispenses clear water. With most of the water dispensed, place selector switch in the "OFF" position and drain off remaining water.

12. Prepare 2 gallons (7.6 liters) of sanitizing solution in a container. Sanitizing solution must be mixed according to manufacturer's instructions to yield 100 ppm available chlorine solution (example: Stera-Sheen Green Label).

13. Pour all the sanitizing solution into the hopper pan. Using a clean brush scrub the hopper walls.

14. Place the selector switch to the "CLEAN" position and allow the beater to run for 5 minutes.

15. Place an empty container under the dispensing head. Drain the sanitizing solution from the cylinder by slowly pulling down on the dispense handle. Open and close the handle several times while draining.

16. With most of the sanitizing solution drained, Place the selector switch to the "OFF" position and drain remaining solution from the freezer and close the plunger.

17. Proceed to sections 6 DISASSEMBLY AND CLEANING, 7 ASSEMBLY AND 8 STARTUP INSTRUCTIONS.

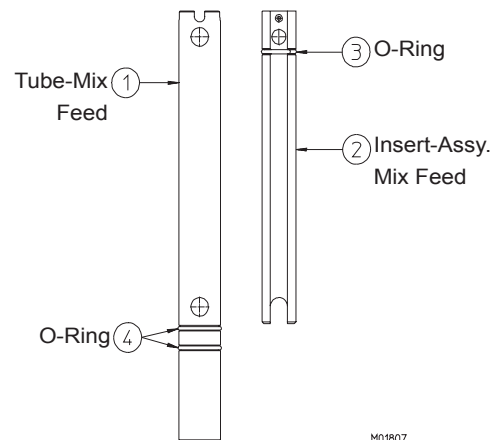

Figure 9-3

10 Product Information

10.1 Overrun

As mix is frozen in the freezing cylinder, air is incorporated into the mix to increase its volume, as well as enhance the taste and texture of the finished product. The increase in volume is called *overrun*. Fifty percent overrun means a volume increase of 50%—10 gallons of liquid mix has become 15 gallons of finished product.

Controlled overrun is important to maintain consistency in product quality. Too much overrun (air) results in a light, fluffy product lacking the cold, refreshing appeal of a quality product. Too little overrun results in a wet, heavy product.

To correctly measure the overrun, perform the following steps:

- a. Place an empty pint container on the scale* and adjust your scale to zero.
- b. Remove the container from the scale and fill with liquid mix. Measure and record the weight.

c. Remove the liquid mix and fill the same container with frozen product. Be sure there are no voids or air spaces in the container.

d. Strike off the excess product so it is even with the top of the container and measure the weight.

e. Use the following formula to figure overrun percentage:

“Weight of liquid mix minus weight of frozen product/divided by the frozen weight.” See example.

Example:

Weight of one pint of mix = 18 oz.

Weight of one pint frozen product = 12 oz.

Difference = 6 oz.

6.0 oz. divided by 12 oz. = .5

.5 x 100 = 50% overrun

* Your Electro Freeze Distributor can provide a scale (P/N HC158049) that is graduated in overrun percentage.

10.2 Rerun

If local health codes permit the use of rerun make sure to follow these procedures:

1. Store rerun mix in a clean, sanitized container.
2. Store in a cooler with a temperature below 40°F (4.4°C).
3. DO NOT prime the machine with rerun. Always skim off and discard foam. Then combine the rerun with fresh mix in a ratio of 50/50 and add to the hopper during operation.
4. Once a week run the mix as low as possible and discard after closing. This will break the rerun cycle and reduce the possibility of high bacteria and coliform counts.

NOTE: Rerun product is unable to accept the same amount of air as fresh product. As a result, the quality will be affected and product may appear grainy and icy.

For further information contact your local Electro Freeze distributor or the Service Department of H. C. Duke & Son, LLC, phone (309) 755-4553 or (800) 755-4545.

11 Syrup Flavor System

The syrup flavor system is included with all CS704 shake freezers. This system

allows you to serve a vanilla shake and four other flavors by the press of a button.

11.1 Syrup Line Disassembly and Sanitizing

Important:
Do not use the "AUTO" position with sanitizer or water in the cylinder. The freezer will be damaged.

The syrup line system should be cleaned every 30 days. The freezer should be fully cleaned prior to syrup line cleaning. Records should be maintained to record last cleaning of freezer and syrup lines.

Sanitizer noted in this section must be prepared according to manufacturer's instructions to yield 100ppm strength chlorine solution (Example: Stera-Sheen® Green Label) Use warm water (100-110°F or 37- 43°C)

NOTE: It is your responsibility to be aware of, and conform to, the requirements for meeting local, state, and federal laws concerning the frequency of cleaning and sanitizing the syrup lines.

1. Wash and sanitize your hands and forearms before cleaning syrup lines.
2. With the syrup pickup tube in the syrup bottle, disconnect syrup hose from the pump by pushing on the metal clip of the connector. (see figure 11-1). Slowly pull the pickup tube out of the syrup bottle

allowing the syrup from the tube and hose to drain back into the bottle. Place the stainless steel pickup tube in an empty bucket. Repeat for each flavor and take hoses to sink and flush with hot water (122°-140°F or 50°-60°C). Remove syrup bottles from the cabinet. Fill the bucket with hot water and reconnect the syrup hoses to the pumps.

3. Place an empty container under the mix chamber. Turn the syrup pump switch to the "ON" position. Select a syrup flavor by pushing the proper button (see figure 11-2) and then press the syrup prime/calibrate button (see figure 11-3, item 2) to purge syrup from the line. Hold the button and allow at least 1-1/2 cups of hot water to flow through the tube and mix chamber. Continue until the water runs clear.

4. Repeat step 3 with the remaining three syrup flavors.

Note: At every cleaning or when a new syrup bottle is opened, the cap with hole for the syrup tube must be washed, rinsed, and soaked in sanitizer for 5 minutes before installing on bottle.

5. With a container under the mix chamber turn the selector switch to clean and press the rinse button for 5 seconds. Spinner should be engaged splashing water in mixing chamber.



Figure 11-1 Removal of syrup lines to bottles



Figure 11-2

11.1 Syrup Line Disassembly and Sanitizing - continued

7. Disconnect each outlet hose from pump. Remove each pump head from the body by twisting 15° counterclockwise and pull straight out. Remove the hose assembly from pump head and o-rings from connectors. Wash, rinse, and soak in sanitizer for 5 minutes. Use 3/8" brush to clean the inside of tubes.

Important:

The peristaltic, pickup and syrup tubes for the chocolate line are larger and must be used only for the chocolate syrup.

8. Take a clean sanitized cloth and wash all soiled surfaces inside cabinet. Disconnect the syrup and water lines from the mix chamber. Remove the

mix chamber and mixing shaft from the dispense head. Take parts to the sink, remove the o-ring and then wash, rinse and soak in sanitizer for 5 minutes. Wash and spray sanitizer on the bottom of the plunger in the dispense head.

9. Fill a small cup with sanitizer. Dip the syrup line quick connects in sanitizer for 30 seconds flushing residue out of connector. Use a small brush if necessary to remove hardened syrup. Repeat dipping on outlet quick connect on syrup pump. Reassemble mixing shaft and mix chamber to dispense head. Reconnect syrup lines.

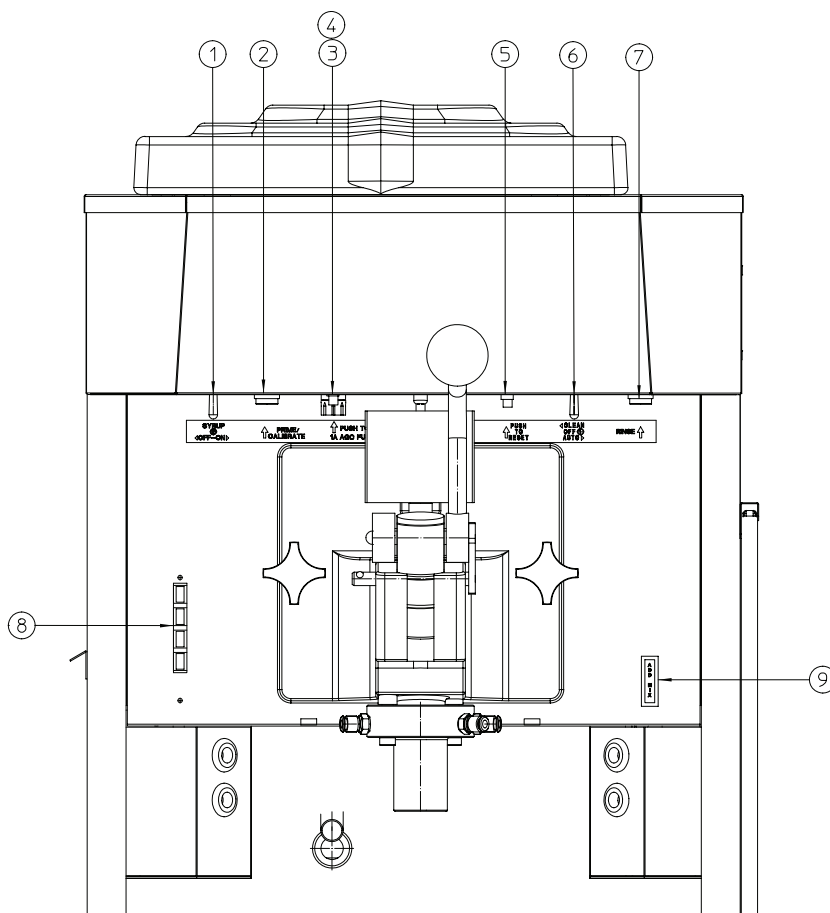

Figure 11-3

11.2 Syrup Line Assembly And Sanitizing

Important:

The chocolate syrup is a different viscosity and requires different hoses. Always be aware of this when assembling.

1. Place a silicone bead of a lubricant [i.e. Dow Corning Compound 7, HC158066] on the outside of each pump peristaltic tube. Wrap the peristaltic tube around the pump head centering it on the rollers. Place the head in the housing making sure the white plastic coupling is outside of the housing and the black tie wrap is inside as shown in figure 11-4.

2. Open the cabinet below the freezer to install the pump housings. The pump housing with the clear peristaltic tube is to be used on the pump with the brown colored potentiometer dial (see figure 11-5).

Important:

The clear larger hose is to be used only for the chocolate syrup.

Line up the center of the pump head to fit into the pump drive housing mounted on the cabinet back wall, turn until it snaps into place.

3.

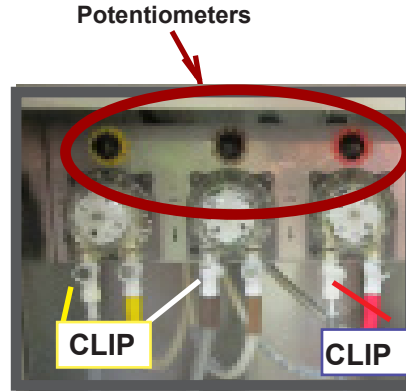

Figure 11-5

Place the three (3) remaining pump heads on the mix pumps in the cabinet.

4. Connect the syrup lines from the freezer to the pumps. The color coded hoses need to be matched to the corresponding color coded on the potentiometer dials above the mix pumps.

5. Sanitize the syrup line system.

a. Prepare 2 gallons (7.6 liters) of sanitizing solution in a container. Sanitizing solution must be mixed according to manufacturer's instructions to yield 100 PPM strength chlorine solution. (example: Stera-Sheen Green Label). Use warm water (100-110°F or 37-43°C) to wash, rinse, and sanitize. Fill a clean empty bucket with 2 gallons of sanitizing solution.

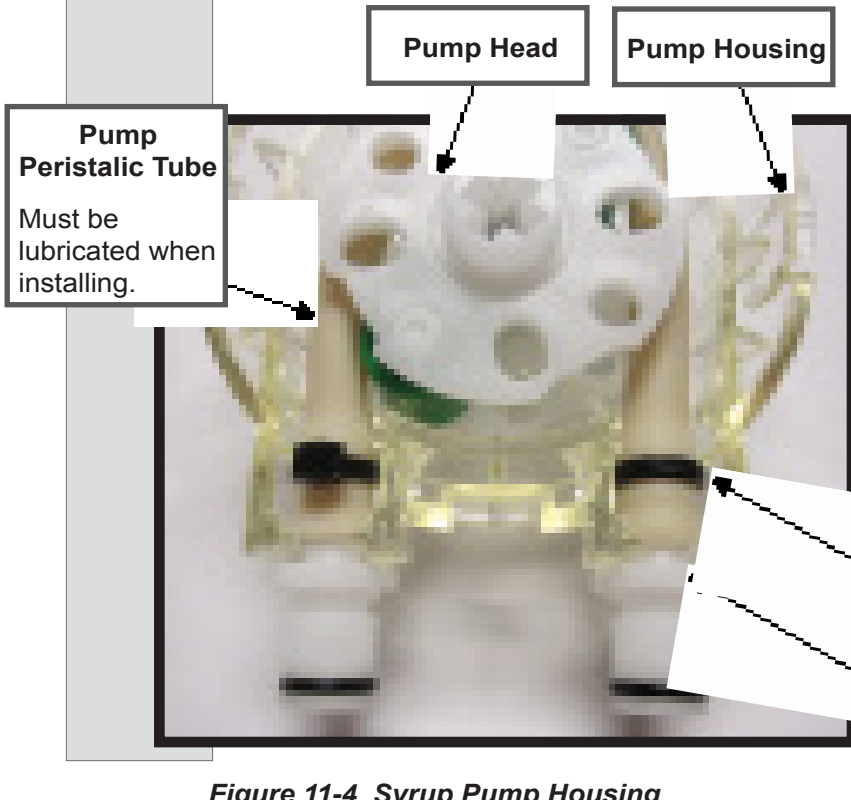

Figure 11-4 Syrup Pump Housing

—continued

11.2 Syrup Line Assembly and Sanitizing - continued

Important:

Do not use unapproved sanitizer or laundry bleach. These materials may contain high concentrations of chlorine and will chemically attack freezer components.

b. Wash and sanitize your hands and forearms.

c. Place the bucket of sanitizing solution on the floor by the cabinet. Place the syrup bottle caps with the holes in the lid, the black cap boots and the stainless steel ends of the pickup tubes into the bucket of sanitizer. Be sure there is no loop in pickup tube so sanitizer will contact all surfaces of tubes.

d. Place an empty bucket or container under the dispensing head. Turn syrup system switch to the "ON" position. (see figure 11-6, item 1)

e. Select a syrup flavor by pushing the proper button then press the syrup prime/calibrate button (see figure 11-4 item 2). Hold the button until sanitizer is flowing into bucket. Continue holding button for one (1) minute.

f. Repeat step 5e with the remaining three syrup lines.

g. Allow sanitizer to soak in syrup lines for 5 minutes.

h. Place each syrup bottle cap from the sanitizing solution onto the syrup bottles. Then place a black boot cover on each bottle cap.

i. Disconnect a hose from the pump by pushing on the metal clip of the connector (see figure 11-5). Remove the pickup tube from the bucket of sanitizer, draining sanitizer back into the bucket. Reconnect hose to pump.

Important:

The largest pickup tube into the chocolate syrup bottle.

j. Repeat step 5i with the remaining three syrup lines. Refer to the potentiometers or door decal to connect the proper flavor to the proper pump.

k. Select one flavor, press the syrup prime/calibrate button until the syrup line has been purged of sanitizer. Pure mix should appear at the mixing chamber on dispense head.

l. Press water button (7 figure 11-5) to clear line.

m. Repeat step 5j and 5k for remaining syrup flavors.

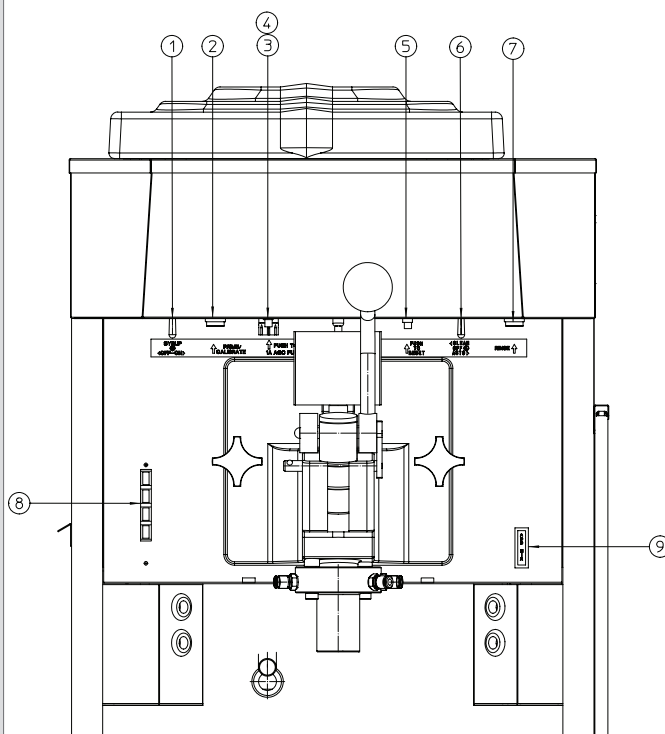

Figure 11-6

11.3 Syrup Calibration

NOTE: Time how long it takes to fill a medium shake and calibrate the syrup pumps so that 1½ oz. of syrup is dispensed in that time.

1. Sanitize and prime each syrup line as described in section 11.2.

2. Select a syrup flavor by pushing the proper button on the front of the freezer. Disconnect that mix chamber syrup tube from the front panel connector by pushing the metal clip in. Attach the coupling insert (see figure 11-7) to the fitting by pushing the mating end into the panel connector unit it clicks. Place the barb end of the coupling insert into the beaker as shown in figure 11-8.

3. Press the syrup prime/calibrate button for 5 seconds using a stop watch or second hand. The measure of syrup dispensed into the beaker should be 1½ oz. If it is not you will have to adjust the potentiometer.

4. Repeat steps 2 and 3 for other flavors.

5. Turn the syrup pump switch to "OFF".

6. Open the cabinet door to allow access to the four flavor adjustment potentiometers located above the mix pumps. See figure 11-9.

7. Approximate setting for the adjustment potentiometers is 7.

8. Calibration levels for each flavor of syrup should be adjusted to 1½ oz.

9. Select the proper potentiometer for the flavor to be adjusted.

a. If the amount of syrup dispensed into the beaker is less than 1½ oz. turn the potentiometer of that syrup line a few degrees **clockwise for MORE SYRUP**.

b. If the amount of syrup dispensed into the beaker is more than 1½ oz. turn the potentiometer of that syrup line a few degrees **counter-clockwise for LESS SYRUP**.

10. Close the cabinet door. Place the syrup pump switch in the "ON" position.

11. Repeat steps 2 and 3 to check calibration. If further adjustment is needed repeat steps 5 through 10.

12. When desired syrup dispense rate is achieved, remove the coupling insert and reconnect the mix chamber syrup tube.

Mating End



**Figure 11-7 Coupling Insert
Part No. HC121061**

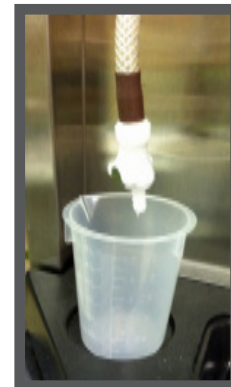

**Figure 11-8 Calibration Beaker
Part No. HC196109**

Potentiometers

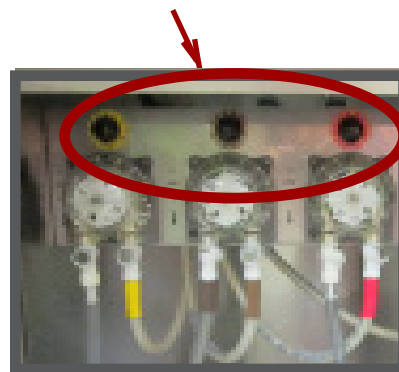

Figure 11-9

12 Routine Maintenance

Electro Freeze recommends the following schedule to help maintain your equipment in like-new operating condition. Take the time to learn and perform these routine procedures and receive in return many years of valuable service from your freezer. Protect your investment.

DAILY

1. Disassemble, wash, rinse, sanitize, air dry, reassemble and sanitize all parts that come into contact with the mix or product.



CAUTION

To prevent bacteria growth, remove all O-rings when cleaning. Failure to do so could create a health hazard.

2. Clean and sanitize syrup lines with sanitizing solution.
3. Clean the cylinder and drain tube with the appropriate brushes.
3. Upon cleaning, inspect and lubricate all seals and O-rings as instructed that come into contact with mix. Replace any O-ring that is worn, torn, or loose-fitting.
4. Wipe all exterior surfaces of the freezer to remove any splattered mix.
5. Check overrun and temperature of the product.

WEEKLY

1. Carefully inspect all parts for wear including, seals, O-rings, mix transfer tube and blades.

2. Replace as required.
Replace blades if worn 3/16" or more.

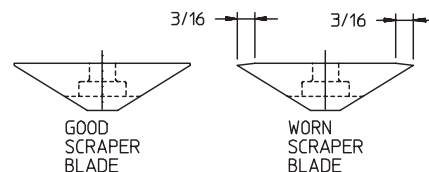

3. Check the beater tangs and drive shaft for wear.

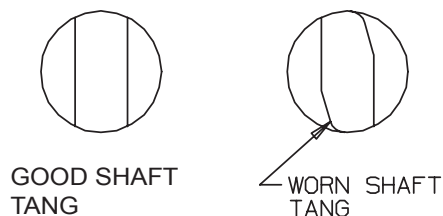

A worn coupling will have a nonparallel shape on the drive opening.

4. Check the air filter and clean as necessary. After cleaning apply spray adhesive, p/n HC162548.

12 Routine Maintenance — continued

MONTHLY

A. Test Head Switch.

The head switch feature is designed to prevent the beater shaft from being accidentally activated. It is essential that the proper operation of this switch be verified on a routine basis. Use the following instructions to test for proper operation:

1. Be sure all switches are in the “OFF” position.
2. Disconnect the main power supply.
3. Remove the dispense head and beater shaft assembly.
4. Connect the main power supply.
5. Turn the selector switch to the “CLEAN” position.



CAUTION
Moving parts. Do not place hands in the freezing cylinder. Severe personal injury could result.

6. Look inside the freezing cylinder toward the rear. The drive shaft coupling should **NOT** be turning. Turn the selector switch to “OFF” and disconnect the main power supply.
7. If the drive shaft coupling is turning, or you are unable to determine whether or not the shaft is turning, turn the switch to the “OFF” position, disconnect the main power supply, and contact your Electro Freeze distributor for service. **DO NOT** place the freezer in service until the problem has been fixed.

MONTHLY

B. Test Flex Cover Switch.

The flex cover switch feature is designed to prevent the spinner shaft from being accidentally activated. It is essential that the proper operation of this switch be verified on a routine basis. Use the following instructions to test for proper operation:

1. Be sure all switches are in the “OFF” position.
2. Disconnect the main power supply.
3. Remove the flex shaft cover.
4. Connect the main power supply.
5. Turn the selector switch to the “CLEAN” position.



CAUTION
DO NOT touch or get too close to moving parts. Clothing, jewelry, hair or other body parts may become caught in the machine and result in personal injury.

6. Place a container under the dispensing plunger.
7. Push the rinse switch button. The spinner shaft should **NOT** be turning. Water will be dispensed. Turn the selector switch to “OFF” and disconnect the main power supply.
8. If the spinner shaft is turning, or you are unable to determine whether or not the shaft is turning, turn the selector switch to the “OFF” position, disconnect the main power supply, and contact your Electro Freeze distributor for service. **DO NOT** place the freezer in service until the problem has been fixed.

12 Routine Maintenance — continued

QUARTERLY

A. Air Condenser.

Freeze Distributor to remove dirt, lint and dust.

Important:

Never use a screwdriver or sharp object to clean between fins.

Both air and water cooled freezers have an air condenser. The condenser fins need to be cleaned by your Electro

B. Refrigeration System

Have your Electro Freeze Distributor check the refrigeration system and make any necessary adjustments.

WARNING!

Failure to properly maintain/clean your air condenser can cause premature compressor failure. Compressor failure due to improper condenser care will void the compressor warranty.

ANNUALLY



CAUTION

To avoid electrical shock or contact with moving parts, make sure all switches are in the "OFF" position and that the main power supply is disconnected.

1. Contact your Electro Freeze Distributor for service to replace drive belts.
2. Contact your Electro Freeze Distributor to have the inside of the freezer cleaned, including base, side panels, condenser, etc.
3. Contact your Electro Freeze Distributor to check water-cooled condenser and flush clean to remove scale and deposits if necessary.

**USE ORIGINAL OR AUTHORIZED REPLACEMENT PARTS ONLY
WITH THIS FREEZER.**

Should you have any questions on items which are not included in this schedule or problems where service assistance is needed, please call your local Distributor or H. C. Duke & Son, LLC, *Electro Freeze*, Service Department for factory service assistance.

Phone number: (309) 755-4553

Fax number : (309) 755-9858

(800) 755-4545

E-mail: service@hcduke.com

12 Routine Maintenance — continued

Winter Storage

To protect the unit during seasonal shutdown, it is important to store the CS700 Shake Freezer properly. Please use the following procedures:

1. Disconnect all power to the freezer.
2. Disassemble and wash all parts that come into contact with the mix with a warm, mild detergent solution. Rinse in clear water and dry all parts thoroughly.
3. Store the loose parts, such as the head assembly, beater assembly, and pump parts in a safe, dry place.
4. Do not lay heavy objects on the plastic or rubber parts.
5. Cover the freezer and all loose parts to protect them from dust or other elements that could contaminate them while in storage. Place the freezer in a dry location.
6. On air-cooled freezers, have condenser fins cleaned.

13 Troubleshooting Charts**SAFETY**

THIS SAFETY ALERT SYMBOL IDENTIFIES IMPORTANT PERSONAL SAFETY MESSAGES IN THIS MANUAL. WHEN YOU SEE THIS SYMBOL, BE ALERT TO THE POSSIBILITY OF PERSONAL INJURY. DO NOT ATTEMPT TO CONTINUE UNTIL THE SAFETY PRECAUTIONS ARE THOROUGHLY UNDERSTOOD.

CAUTION

All maintenance adjustments must be done by an Electro Freeze Distributor or authorized service technician.

CAUTION

To avoid electrical shock or contact with moving parts, make sure all switches are in the "OFF" position and that the main power supply is disconnected. Some freezers have more than one disconnect switch.

Important:

Refrigerants are hazardous to the earth's atmosphere. To protect our environment, use a refrigerant recovery/recycling unit whenever removing refrigerant from the system.

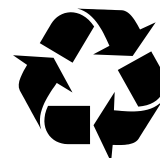

13 Troubleshooting Charts — continued

PROBLEM	PROBABLE CAUSE	REMEDY
Unit does not operate.	1. Freezer unplugged.	1. Plug in freezer.
	2. Fuse or breaker blown at main disconnect.	2. Make sure your freezer is connected to a separate circuit independent from any other electrical equipment. Have technician check fuse or breaker size and check for low voltage; if not within 10% of nameplate rating call power company.
	3. Actuator rod not installed.	3. Install actuator rod.
	4. Off on high pressure cut-out control.	4. Water turned off or defective water regulating valve. Check water supply. (Water Cooled)
	5. Circuit breaker tripped.	5. Reset. If trips again contact your Electro Freeze Distributor for service
	6. Faulty selector switch.	6. Contact your Electro Freeze Distributor for service.
	7. Disconnected or broken wire in electrical circuit.	7. Contact your Electro Freeze Distributor for service.
Mix or water leaking from drain tube to drip tray.	1. Damaged beater shaft seal or installed improperly.	1. Replace cup seal. Install properly.
Mix leaking at dispensing head.	1. Faulty head o-ring.	1. Replace o-ring.
	2. Head not properly installed.	2. Install head properly. Replace o-ring if pinched.
	3. Faulty Plunger o-ring or wrong o-ring in wrong o-ring groove.	3. Check the o-ring chart.
Dispensed product too soft. (Product temperature above 28°F [-2.2°C])	1. Dirty or blocked condenser, restricted air flow.	1. Unblock condenser or have cleaned by your Electro Freeze Distributor.
	2. Torque control not set firm enough.	2. Contact your Electro Freeze Distributor for service.
	3. Component failure.	3. Contact your Electro Freeze Distributor for service.
	4. Leak in refrigeration system resulting in little or no refrigeration.	4. Contact your Electro Freeze Distributor for service.

13 Troubleshooting Charts — continued

PROBLEM	PROBABLE CAUSE	REMEDY
Product dispenses slowly out of dispensing head.	1. No product in hopper.	1. Fill hopper.
	2. Product too cold.	2. See "Dispensed product too hard."
	3. Mix feed tube not open.	3. Check mix feed tube setting.
Dispensed product too hard.	1. Torque control erratic or set too firm	1. Contact your Electro Freeze Distributor for service.
	2. Low suction pressure, refrigeration system.	2. Contact your Electro Freeze Distributor for service.
	3. Mix feed tube not open.	3. Check mix feed tube setting.
Freezer runs continually and product continues to get colder.	1. Plunger not fully closed.	1. Close plunger completely.
	2. Starter or relay contact points stuck.	2. Contact your Electro Freeze Distributor for service.
	3. Torque control not set properly or faulty.	3. Contact your Electro Freeze Distributor for service.
	4. Suction pressure too low.	4. Contact your Electro Freeze Distributor for service.
Compressor motor does not operate when dispensing.	1. Plunger switch defective or out of adjustment.	1. Contact your Electro Freeze Distributor for service.
	2. Time delay defective.	2. Contact your Electro Freeze Distributor for service.
Compressor motor does not operate when dispensing.	1. Plunger switch defective or out of adjustment.	1. Contact your Electro Freeze Distributor for service.
	2. Time delay defective.	2. Contact your Electro Freeze Distributor for service.
	3. Defective torque control.	3. Contact your Electro Freeze Distributor for service.

13 Troubleshooting Charts — continued

PROBLEM	PROBABLE CAUSE		REMEDY	
Product dispenses slowly out of dispensing head.	1.	No product in hopper.	1.	Fill hopper.
	2.	Product too cold.	2.	See "Dispensed product too hard."
	3.	Mix feed tube not open.	3.	Check mix feed tube setting.
Compressor and beater motor operates only when dispensing.	1.	Defective torque control.	1.	Contact your Electro Freeze Distributor for service.
Compressor will not start - hums intermittently (cycling on overload)	1.	Improperly wired.	1.	Contact your Electro Freeze Distributor for service.
	2.	Low line voltage.	2.	Ask power company to increase voltage to not less than 10% below dataplate rating or have transformer installed. Have wire checked for inadequate wire size.
	3.	Open start capacitor. (Single phase only)	3.	Contact your Electro Freeze Distributor for service.
	4.	Defective compressor	4.	Contact your Electro Freeze Distributor for service.

NOTE: Contact your authorized Electro Freeze distributor for instructions prior to warranty compressor replacement.

**QUALITY PARTS
PROTECT
YOUR
EQUIPMENT**

Keep your freezer in excellent condition. Always contact your Electro Freeze distributor for replacement parts and maintenance scheduling.



REPLACEMENT PARTS MANUAL
with ILLUSTRATIONS

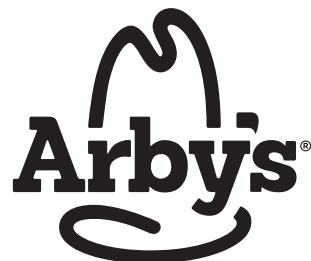

<p>QUALITY PARTS PROTECT YOUR EQUIPMENT</p>	<p>COMPACT SERIES SHAKE FREEZER</p> <p>Model CS704</p> <p>185260-01 6/17</p>
---	--

**KEEP YOUR FREEZER IN EXCELLENT CONDITION. ALWAYS CONTACT
YOUR ELECTRO FREEZE DISTRIBUTOR FOR REPLACEMENT PARTS.**

Replacement Parts Orders

You must have the serial number of your freezer when ordering parts —parts may differ with a particular serial number of the same model.

Parts are listed using terminology that best fits the function of the part. The illustrations in this section will help you to find the correct part number and description. The alphabetized parts list can be used to verify part numbers pertaining to the serial number of your unit.

Place your parts order through your local authorized Electro Freeze distributor.

Name: _____

Address: _____

Phone: _____

If you require any further assistance, contact H. C. Duke & Son, LLC, *Electro Freeze* as follows:



Phone: (309) 755-4553
(800) 755-4545

FAX: (309) 755-9858

E-mail: service@electrofreeze.com

Table of Contents

ILLUSTRATIONS	Figure 1	Head Assembly	2
	Figure 2	Beater Shaft Assembly	3
	Figure 3	Mix Feed Tube Assembly	4
	Figure 4	Plunger Box	5
	Figure 5	Switch Assembly	6
	Figure 6	Electrical Box	7
	Figure 7	Syrup System	8
	Figure 8	Panel View	10
	Figure 9	Side/Rear View	12
	Figure 10	Drive Shaft & Bearing Assembly	14

OTHER LISTS and INFORMATION

Accessories	15
O-Ring Chart	16
Clean & Sanitizing Sheet	17
Syrup System Sheet	19
Alphabetized Parts List	21

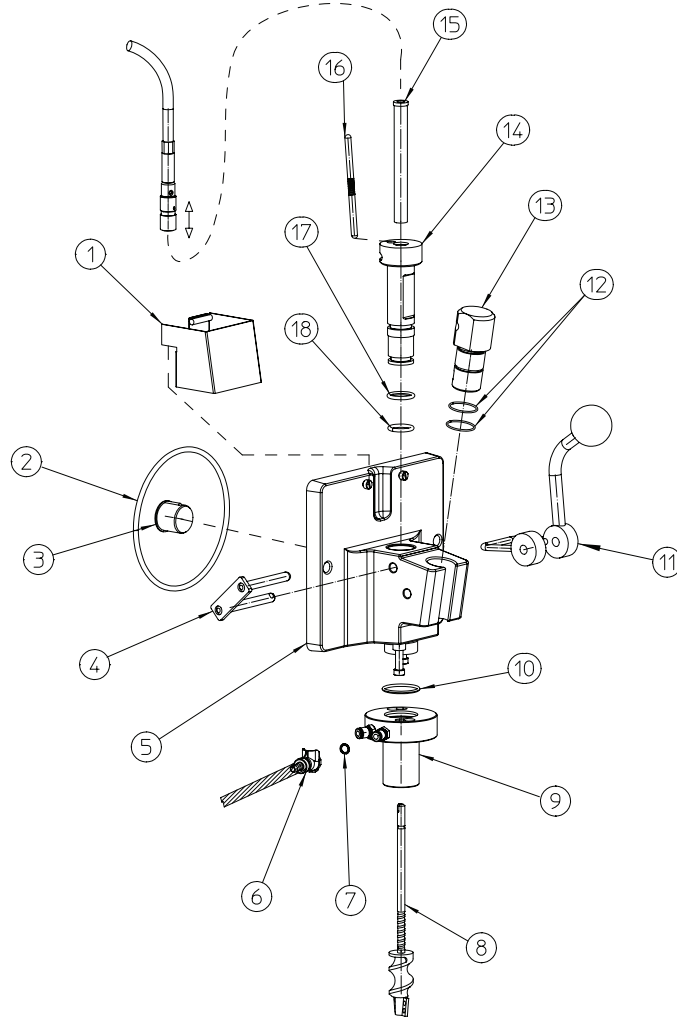

M01997-02

Figure 1 Head Assembly

Item	Part No.	Description
*	HC121006-03	Head-Assy. Complete 4 Flavor
1	HC121020	Cover-Assy Flex Shaft
2	HC160622	O-ring (Head)
3	HC196072	Bushing-Beater Bearing
4	HC113435	Keeper-Assy. Spindle
5	HC121005	Head-Assy. w/Posts 5 FL SH
6	HC160771	Coupling-Body 1/4 Flow 1/4 Barb Shutoff
7	HC160632	O-ring (Syrup Line)
8	HC196291	Shaft-Assy. Mix
9	HC121106-02	Chamber-Assy. Mix
	HC141148-02	Chamber-Mix
	HC121061	Coupling-Assy Insert 1
	HC160650	O-ring
10	HC160650	O-ring (Mix Chamber)
11	HC121019-01	Handle-Assy. Disp. Complete
	HC162629	Knob-Ball 3/8
12	HC160555	O-ring (Pivot Post)

Item	Part No.	Description
13	HC135182	Post-Pivot
14	HC141150	Plunger-Dispensing 5 Flavor
15	HC141151	Bushing-Mixer Shaft
16	HC138611	Rod-Actuator
17	HC160501	O-ring (Plunger-Upper)
18	HC160582	O-ring (Plunger-Lower)
19	HC153422	Shaft-Flexible w/Casing 16-1/2" Does not include item #20.
20	HC121008	Connect-Assy Drive
Not Shown:		
	HC114341	Stud-Assy. Cylinder 1-15/16"
	HC162625	Knob-Hand
	HC151149	Motor-Shake 44W 230v FWR

* Includes Items 2-5, 9, 11-15, 17-18.

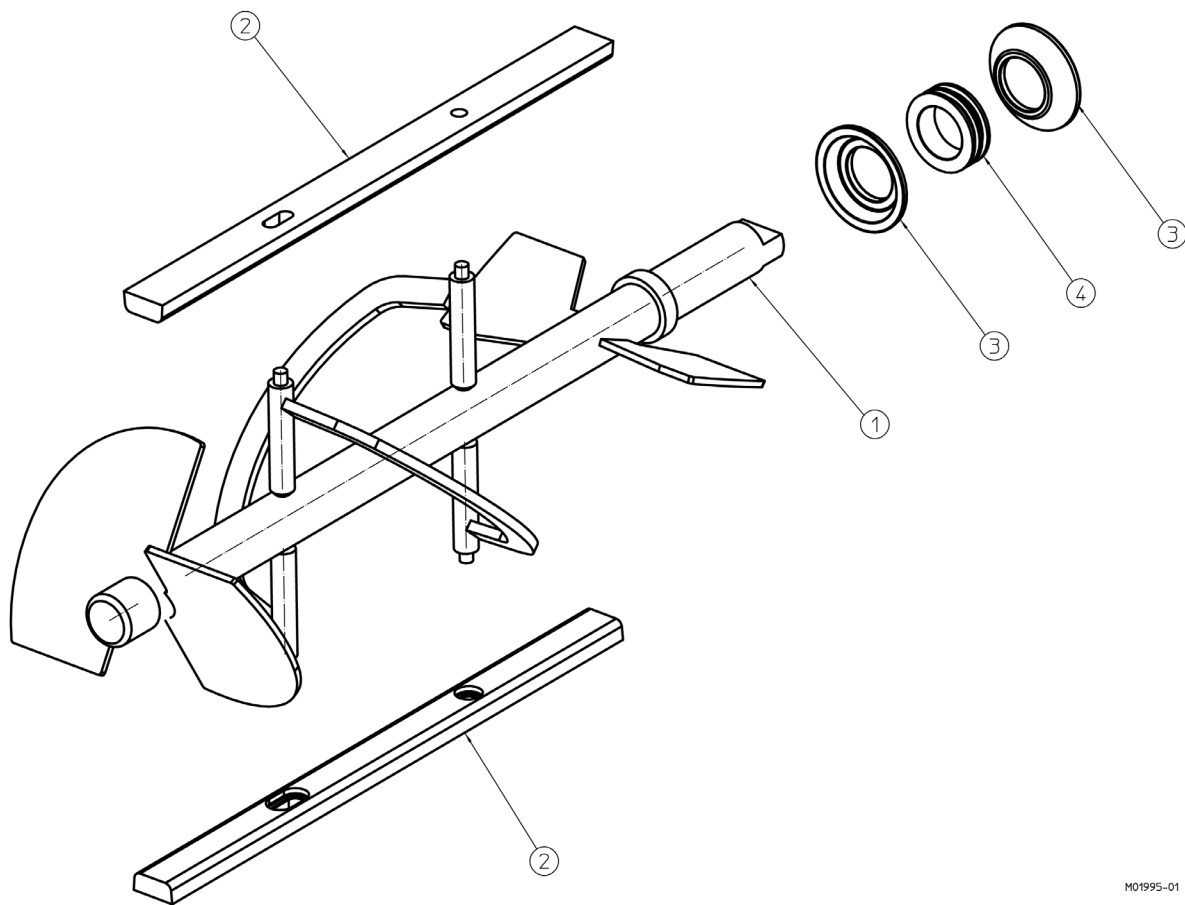

M01995-01

Figure 2 Beater Shaft Assembly

Item	Part No.	Description
1	HC118708	Beater-Assy. Shake Short
2	HC140900	Blade-Scraper Shake Non Rev
3*	HC137593	Washer-Double Shaft Seal
4*	HC160557	Seal-Beater Shaft

* Can be ordered together
 HC115525 Seal-Assy. Shaft Double

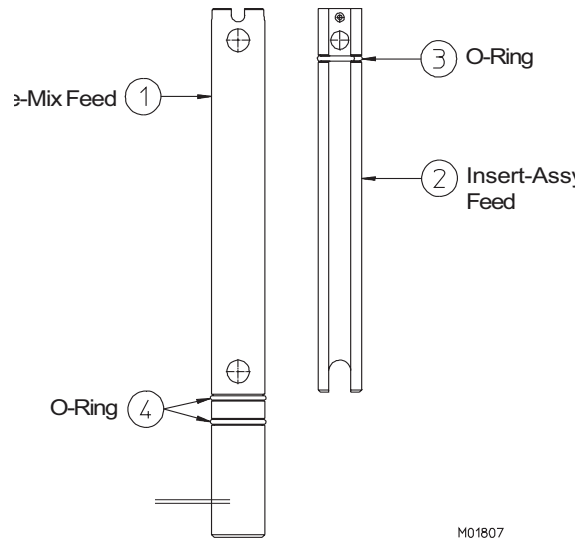

Figure 3 Mix Feed Tube Assembly

Item	Part No.	Description
*	HC120666	Tube-Assy. Mix Feed .313
1	HC140721	Tube-Mix Feed .313 Orifice
2	HC120664	Insert-Assy. Mix Feed (Regulator)
3	HC160611	O-ring (Insert-Regulator)
4	HC160621	O-ring (Mix Feed Tube)

* Includes items 1 through 4.

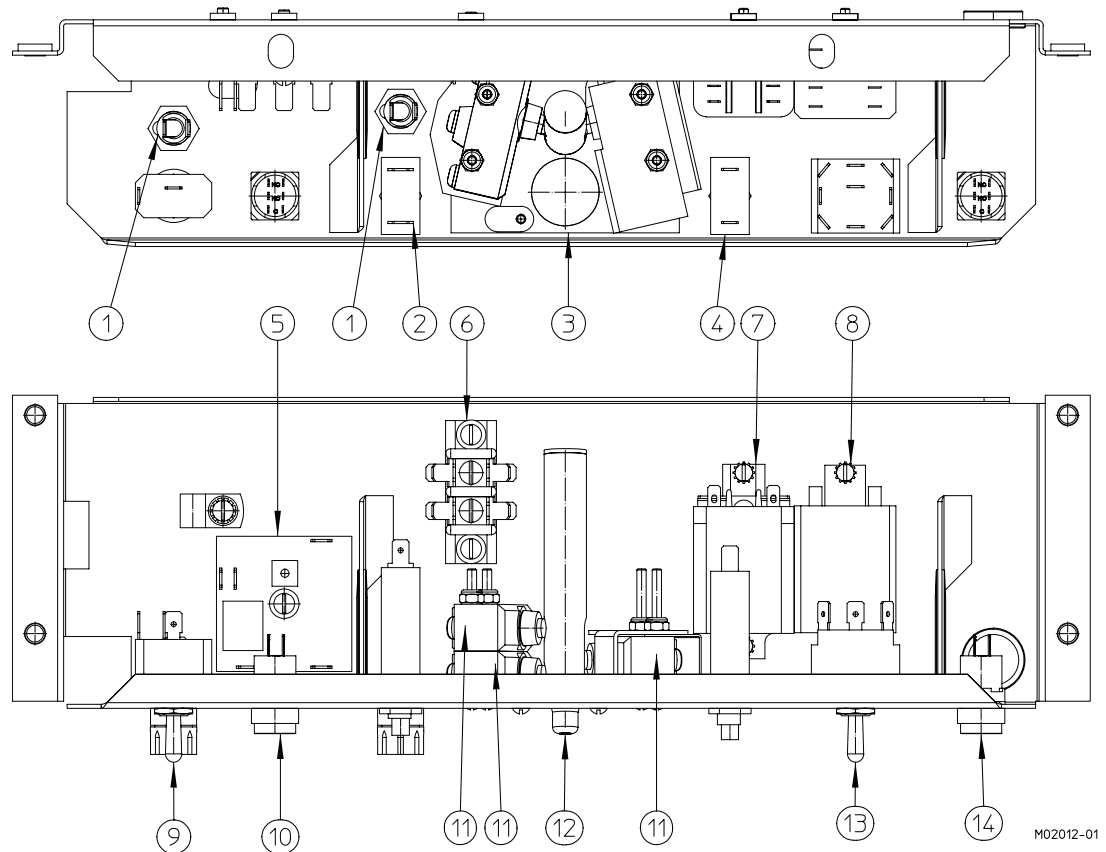
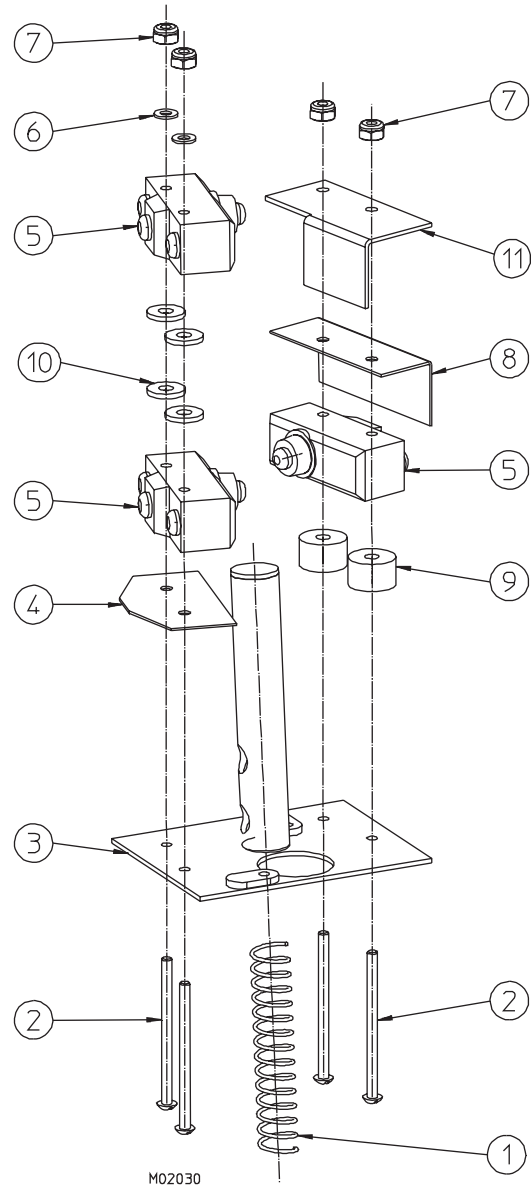

Figure 4 Plunger Box

Item	Part No.	Description
1HC150985 Fuse-Fast AGC 1.0A 1/4 x 1-1/4
2HC150984 Breaker-Circuit 0.7A
3HC121011 Switch-Assy. Plunger (See Figure 5) HC162303Spring-Plunger Rod HC150456Switch-Snap Button
4HC150452 Breaker-Circuit 4.5A
5HC150188 Timer-DOB .5-60 Sec
6HC150798 Terminal-Strip
7HC150381 Relay-Flange Base w/Cover
8HC150343 Relay-Control Flange 3PDT 24VAC
9HC159235 Switch-Toggle SPST
10HC150971 Switch-Push DPDT MOM Black
11HC150456 Switch-Snap Button
12HC137760 Rod-Plunger Switch (Actuator Button)
13HC150465 Switch-Toggle 3PDT Center Off
14HC150971 Switch-Push DPDT Mom Black



**Figure 5 Switch
Assembly**

Item	Part No.	Description
*	HC121011	Switch-Assy. Plunger Shake Pres
1	HC162303	Spring-Plunger Rod
2	HC159973	Screw-RDHM #6-32 x 2 Zn
3	HC141209	Guard-Switch Assembly
4	HC137798	Insulator-Switch
5	HC150456	Switch-Snap Button
6	HC160393	Washer-Flat #6 Brass
7	HC160199	Nut-EI Stop #6-32 ZN
8	HC139175	Insulator-Switch
9	HC137765-01	Spacer-.375 Long
10	HC160157	Washer-1/2 x .196 x 1/16
11	HC141209	Guard-Switch Assy.

* Includes all items above.

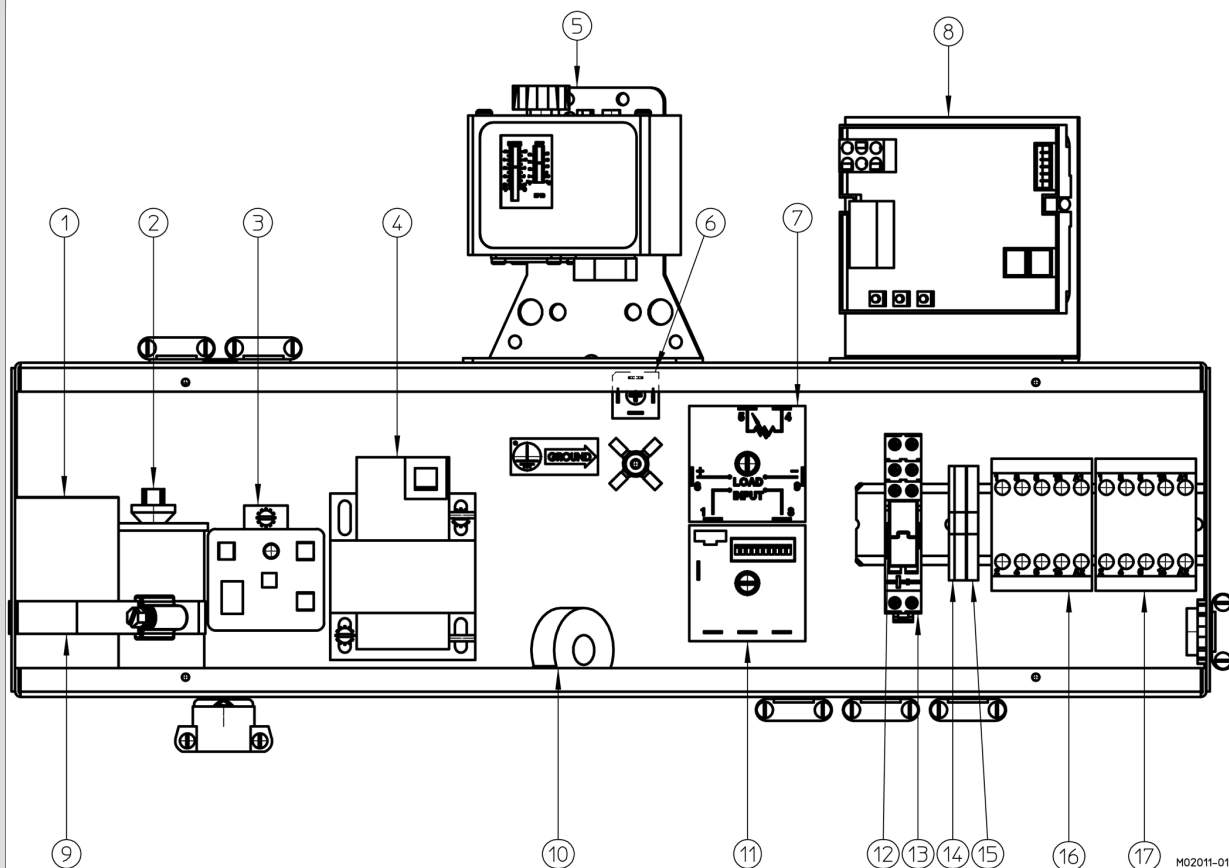

Figure 6 Electrical Box

Item	Part No.	Description
1.....	HC151414	Capacitor-Start
2.....	HC150244	Capacitor-Run
3.....	HC151474	Relay-Compressor Start
4.....	IC574100325.....	Transformer-75VA / 24VAC / MURD
5.....	HC119989	Kit-Thermostat & Retainer
6.....	HC150890	Rectifier-Bridge
7.....	HC150967-01....	Control-Speed 230VAC to DC Motor
8.....	HC120603	Board-Assy. Torque Monitor Shake
9.....	HC160743	Clamp-Hose 3-1/6 to 4
10.....	IC574100349.....	Transformer-Current
11.....	HC120095	Kit-Recyle Timer Wiring Instructions
12.....	HC150097-01....	Relay-Miniature DPDT 230V Coil
13.....	HC150098	Socket-Miniature Relay DPDT
13A.....	HC150166	Clip-Miniature Relay Retaining
14.....	HC150594	Stop-Terminal Block End (Cover)
15.....	HC150591	Block-Terminal
16.....	HC150095	Contactora-Mini 3P (Beater Motor)
17.....	HC150095	Contactora-Mini 3P (Compressor)

Figure 7 Syrup System View (Sheet 1 of 2)

VIEW FROM BACK SIDE OF HC121066-03 BUCKET-ASSY FLAVOR PUMPS

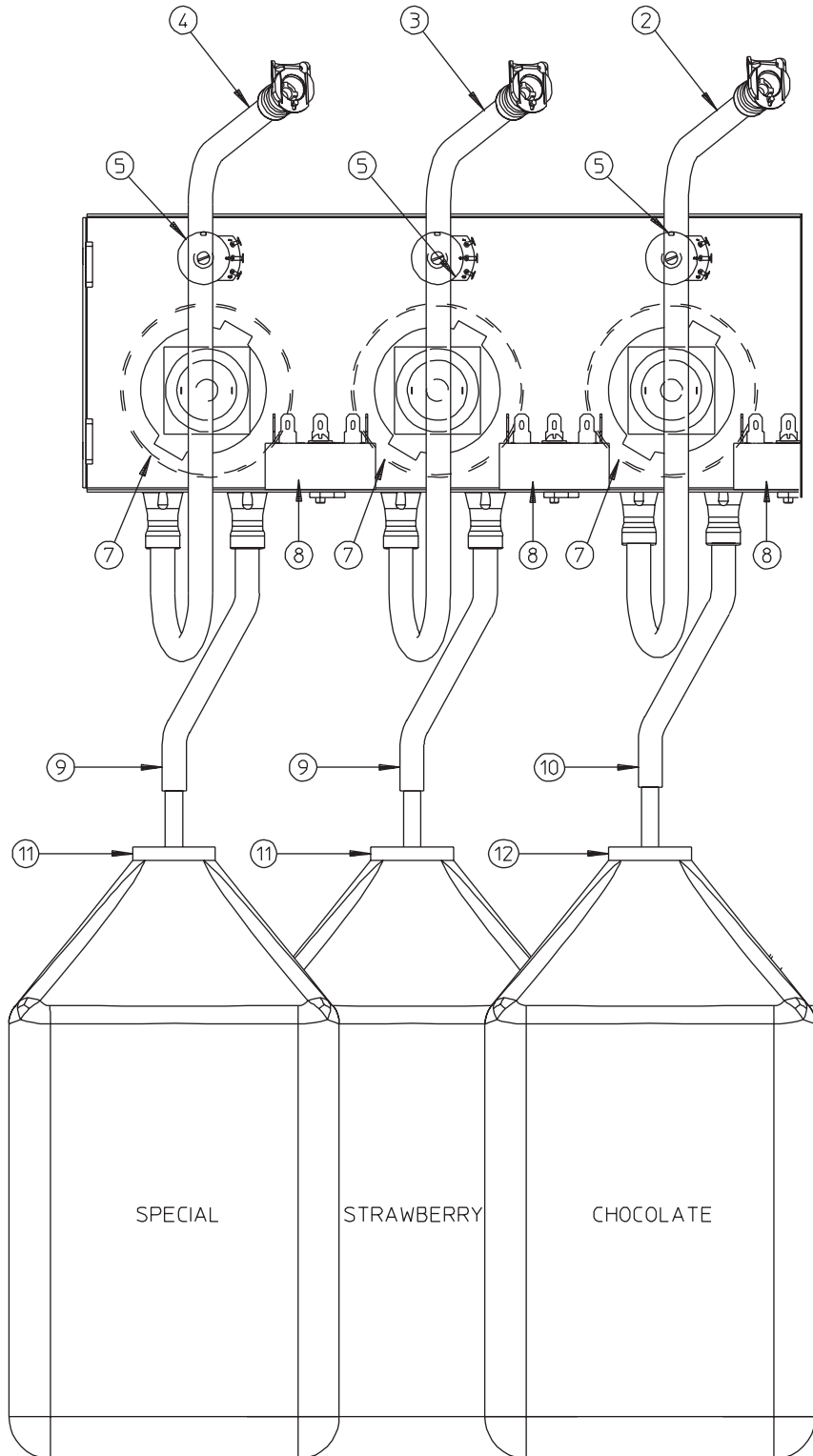

Figure 7 Syrup System View (Sheet 1 of 2)

Item	Part No.	Description
1.....	HC121100	Kit-Tube Assy. Syrup Yellow and Coupling
2.....	HC121101	Kit-Tube Assy. Syrup Brown and Coupling
3.....	HC121102	Kit-Tube Assy. Syrup Red and Coupling
4.....	HC121103	Kit-Tube Assy. Syrup Blue and Coupling
5.....	HC150966	Potentiometer-100K OHM 1-Turn
6.....	HC150982	Housing-Plug 2/Ears 5 Circuit
7.....	HC169101	Pump-Peristaltic Syrup 24VDC
8.....	HC150967	Control-Speed 24VAC to DC Motor
9.....	HC121039	Tube-Assy. Syrup Pick-up
10.....	HC121039-01..	Tube-Assy. Syrup Pick-up 3/8 (Chocolate)
11.....	HC141173	Cap-Bottle Gal Punched
11A.....	HC199050	Boot-Syrup Bottle (Black) (not shown)
12.....	HC141173-01..	Cap-Bottle Gal Punched 7/16 (Chocolate)

Not Shown:

- HC121094
- HC161032
- HC160720
- HC196109

Coupling-Assy. Insert-1/4 Flow
 1/8 NPT (also used in calibration process) HC160770

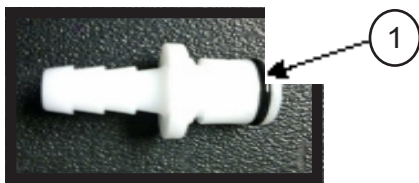

Item	Part No.	Description
1.....	HC160632	O-ring

Pump Peristaltic Tube Assembly

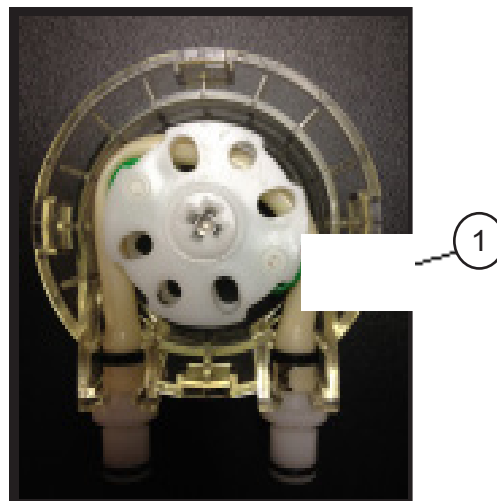

Item	Part No.	Description
1.....	HC120983	Tube-Assy Small Peristaltic
	HC120983-01..	Tube-Assy Large Peristaltic (Chocolate)

Figure 8 Panel View (Sheet 1 of 2)

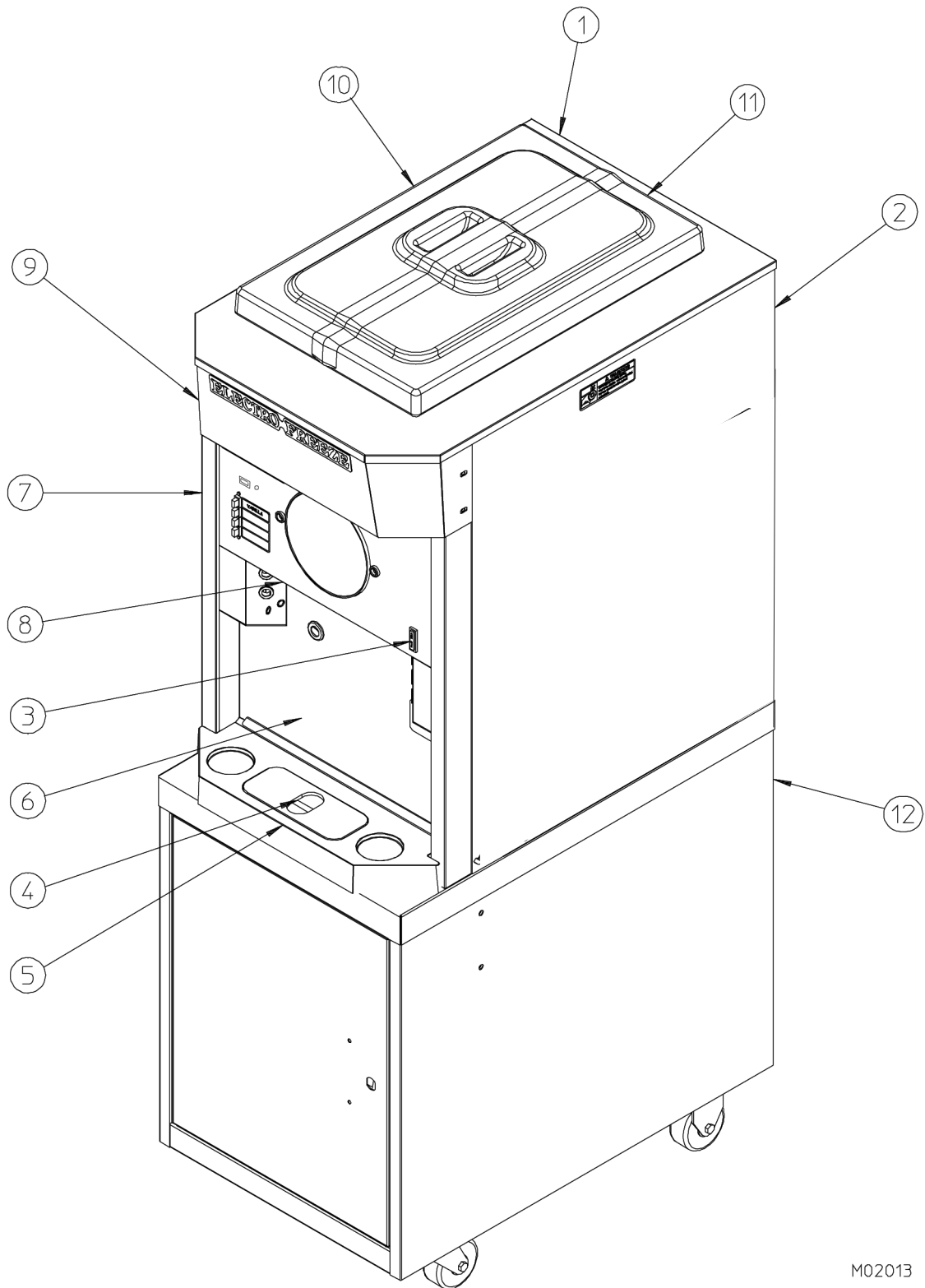

M02013

Figure 8 Panel View (Sheet 1 of 2)

Item	Part No.	Description
1	HC141185	Panel-Rear
2	HC141180	Panel-Side RH
3	HC150541	Light-Indicator 28v ADD MIX
4	HC196261	Cover-Drip Tray
5	HC196260	Tray-Drip
5A	HC140738	Retainer-Drip Tray (Not Shown)
6	HC121017	Panel-Assy. Front 5 Flavor SH
6A	HC159064	Grommet-1.1 OD 7/8 GD x 5/8 ID (Drain Tube)(Not Shown)
7	HC140659	Panel-Side LH CS704
8	HC141161-03	Panel-Dispense 4 Flavor
9	HC121018	Trimstrip-Assy. Tapered
10	HC120804	Panel-Assy. Hopper & Top
11	HC118691	Cover-Assy. Hopper Insulate
12	HC121435-01	Cart-CS Stainless
	HC162200-11	Latch-CS Cart

Not Shown:

HC161300	Switch-Level Float Sensor
HC161301	Float-Level Sensor
HC139230	Deflector-Panel (Left side)

Hardware for Panels		
Panel	Screw	Nut-Speed
Dispense-Top	HC160025	n/a
Dispense-Bottom	HC160076	n/a
Front	HC160048	n/a
Rear	HC160048	n/a
Side	HC159219	n/a
Trimstrip	HC160076	n/a
*N/A - Not Applicable		

CS705 Panel Decals & Labels	
Part No.	Description
HC165025	Beater Warning
HC165250	Cleaning Instructions
HC165093	Clear Overlay
HC164215-01	Flavor
HC165414	Nameplate-Electro Freeze
HC165126	Panel Removal
HC164220	Pump Potentiometer
HC164220-01	Pump Potentiometer Brown
HC164220-02	Pump Potentiometer Red
HC164220-03	Pump Potentiometer Blue
HC164216	Syrup Pump
HC164217	Trimstrip
HC169052	Ventilation 3 in.

Figure 9 Side View (Sheet 1 of 2)

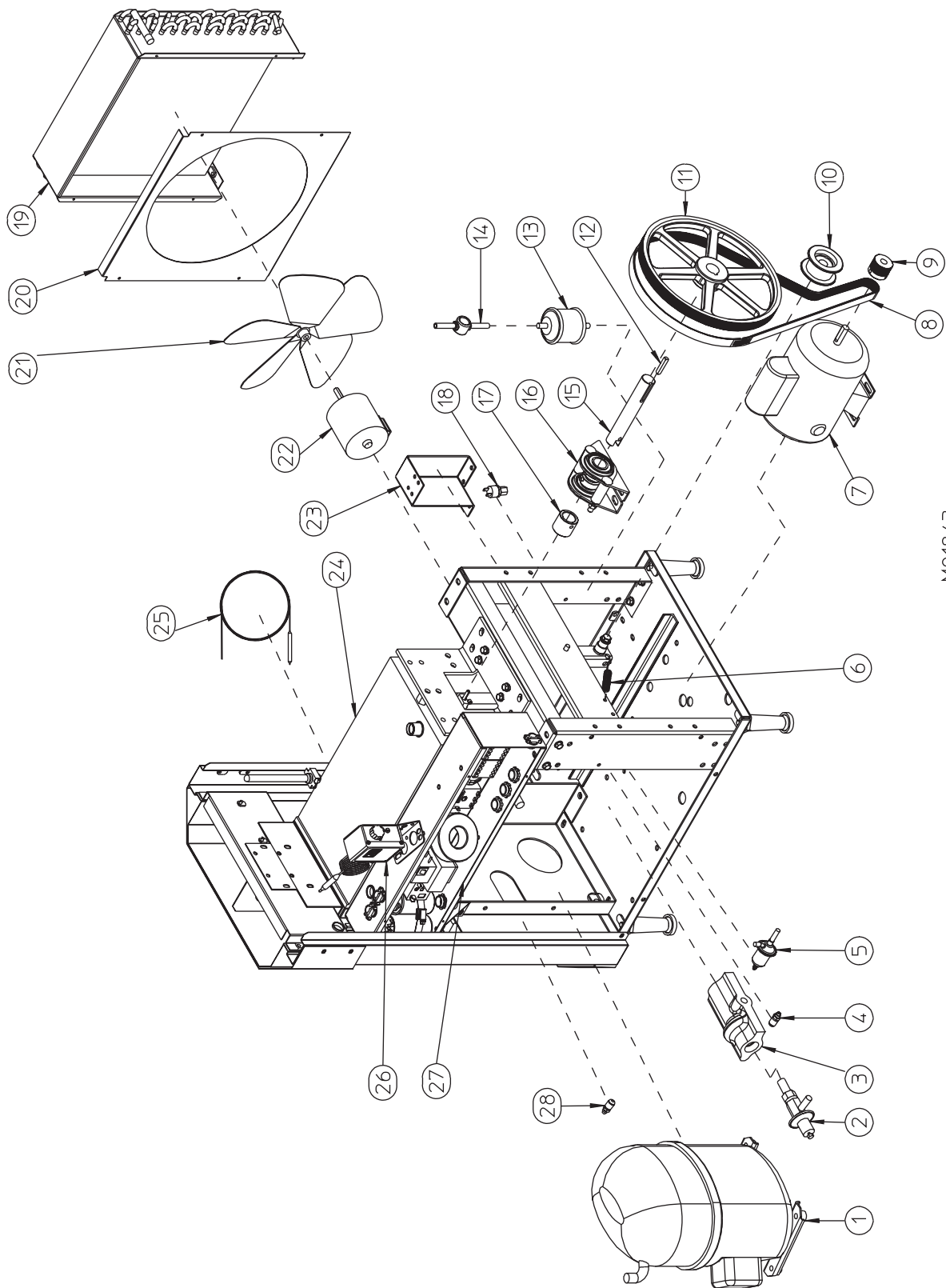

M01843

Figure 9 Side View (Sheet 1 of 2)

Item	Part No.	Description	Item	Part No.	Description
1	HC120602	Compressor-Assy. 208-230-1-60 includes compressor and: HC150244 Capacitor-Run HC151414 Capacitor-Start HC155063 Drier-Filter 3 cu. in. Sweat HC151478 Grommet-Comp.Mfg. HC151474 Relay-Compressor Start HC151479 Sleeve-Comp.Mfg.	18A	HC155419	Valve-Access
2	HC155490	Valve-Automatic Expansion	18B	HC155649	Valve-Core ..
3	HC165531	Insulator-Expansion Valve	19	HC155140	Condenser-Air 14 x 14
4	HC155497	Valve-Access (EPR)	20	HC140656	Shroud-Fan .
5	HC155398	Valve-EPR	21	HC159033	Blade-Fan 12 in. 24°
6	HC162331	Spring-Extension	22	HC151077-01	Motor-Fan 50W 230V 50/60 HZ
7	HC151143	Motor-1/2 HP 115/208-230-1-60 (Beater Motor)	23	HC120580	Bracket-Assy. Fan Mount
8	HC153185	Belt-Poly V	24	HC120417	Cylinder-Assy. Complete
9	HC140654	Sheave-Drive 1.438 PD J8	25	HC155397	Tube-Capillary w/Strainer
9A	HC153323	Key-Drive 1/4" Sq. x 1-1/2" (not shown)	26	HC119989	Kit-Thermostat & Retainer
10	HC120588	Pulley-Assy. Idler Tensioner	27	-----	Electric Box (See Figure 5)
11	HC153614	Sheave-Driven	28	HC155497	Valve-Access (Suction)
11A	HC160033	Screw-SK Set 5/16-18 x 3/8 (not shown)	29	HC120603	Board-Assy. Torque Monitor Shake
12	HC153323	Key-Drive 1/4" Sq. x 1-1/2"	30	HC155708	Valve-Solenoid 1/4 NPT 240V
13	HC155063	Drier-Filter 3 cu in Sweat	<i>Not Shown:</i>		
14	HC155059	Glass-Sight	HC120606	Tube-Assy. Drain	
15	HC140824	Shaft-Drive	HC161032	Filter-In line 3/8 NPT WTR 100 Mesh	
15B	HC160056	Screw-Set 1/4-20 x 1/4 (not shown)	HC151149	Motor-Shake 44W 230v FWR	
16	HC120946	Bearing-Assy Rear (See Figure 7) HC153024 ...Bearing-Ball 1.00ID x 2.0472 OD			
17	HC140823	Cap-Coupling			
18	HC155450	Cut Out-High Pressure 450 PSI			

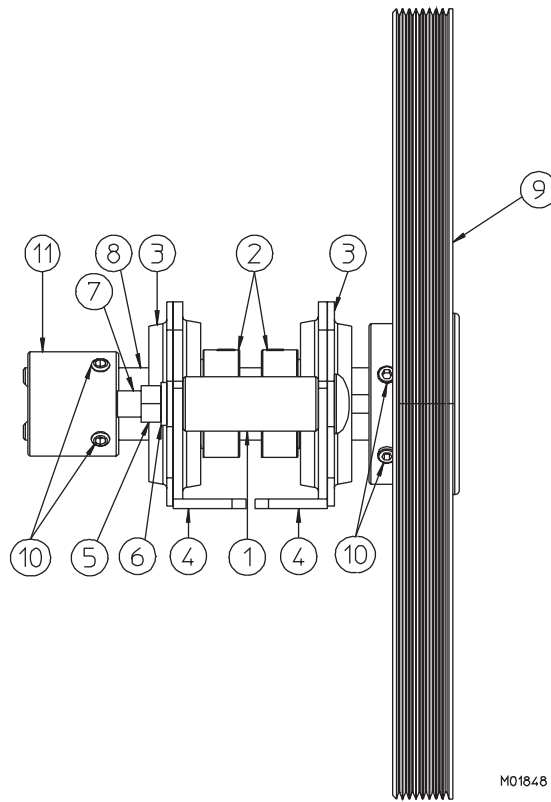

Figure 10 Drive Shaft and Bearing Assembly

Item	Part No.	Description
*	HC120946	Bearing-Assy. Rear
1	HC130189	Spacer-Rear Bearing
2	HC153024	Bearing-Ball 1.00 ID x 2.0472 OD
3	HC153025	Stamping-Retainer Plate
4	HC153026	Stamping-Main
5	HC160105	Nut-Hex 5/16-18 ZN
6	HC160142	Washer-Lock 5/16 ZN
7	HC160415	Bolt-Carriage 5/16-18 x 3 ZN
8	HC140824	Shaft-Drive
9	HC153614	Sheave-Driven
10	HC160056	Screw-SK Set
11	HC140823	Cap-Coupling

* Includes items 1 through 7.

Not Shown:

- HC113948 Bar-Alignment (Loaner)
(used to align bearings to cylinder)
- HC113948-01 ... Bar-Alignment (Purchase)

Accessories

Part No.	Description
HC162548	Adhesive-Filter Spray
HC196109	Beaker-150ML
HC196103	Bottle-Wash 500ML
HC158003	Brush-7/16 x 1-1/8 Double Handle
HC158010	Brush-6 inch w/o Handle (Use with Handle HC158012)
HC158026	Brush-1 inch Diameter 12 inches Long
HC158028	Brush-3/8 Dia x 1/2 21inch Handle
HC158077	Brush-9/16 inch with 36 inch Handle
HC184291	Chart-O-ring (Laminated)
HC121061	Coupling-Assy. Insert 1/4 Flow 1/8 NPT (Used in Calibration Process) includes HC160632 O-ring
HC158051	Cup-Overrun Measuring 1 Pint (Use with P/N 158049 scale)
HC158012	Handle-Brush 36 inch Fiberglass (Use with Brush HC158010)
HC158066	Lubricant-Compound 7 5.3 oz. tube (per tube)
HC158014	Sanitizer-Stera-Sheen Case/4 Jars
HC158014A.....	Sanitizer-Stera-Sheen 4 lb. jar
HC158049	Scale-Overrun
HC184589	Sheet-Clean & Sanitize CS704
HC184590	Sheet-Clean & Sanitize Syrup System CS704
HC169374	Tool-O-Ring Removal

HC184291

SHAKE DISPENSING HEAD

REV. 02

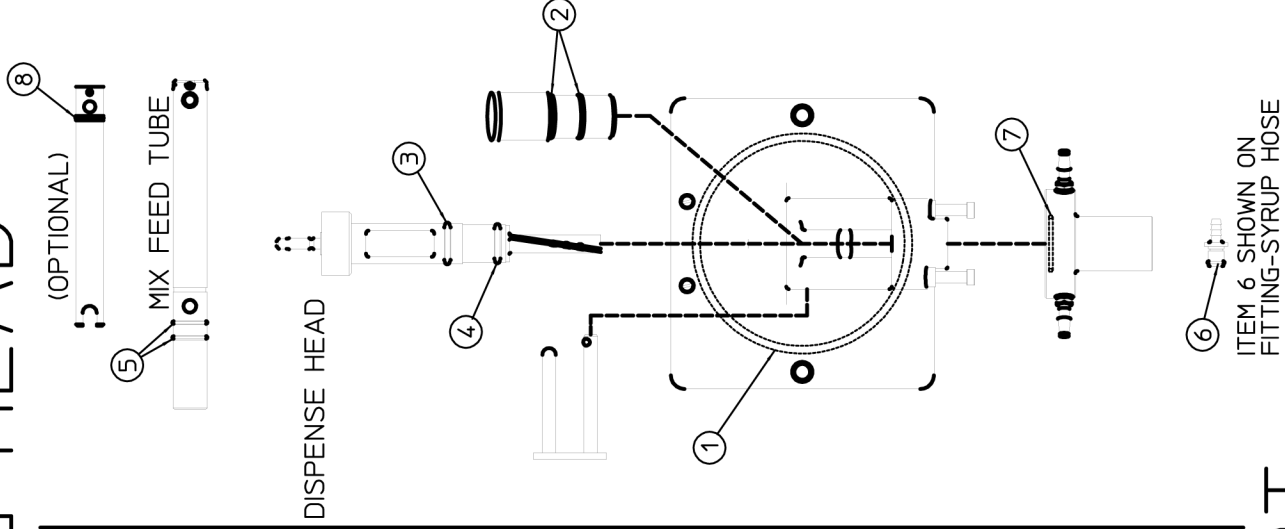
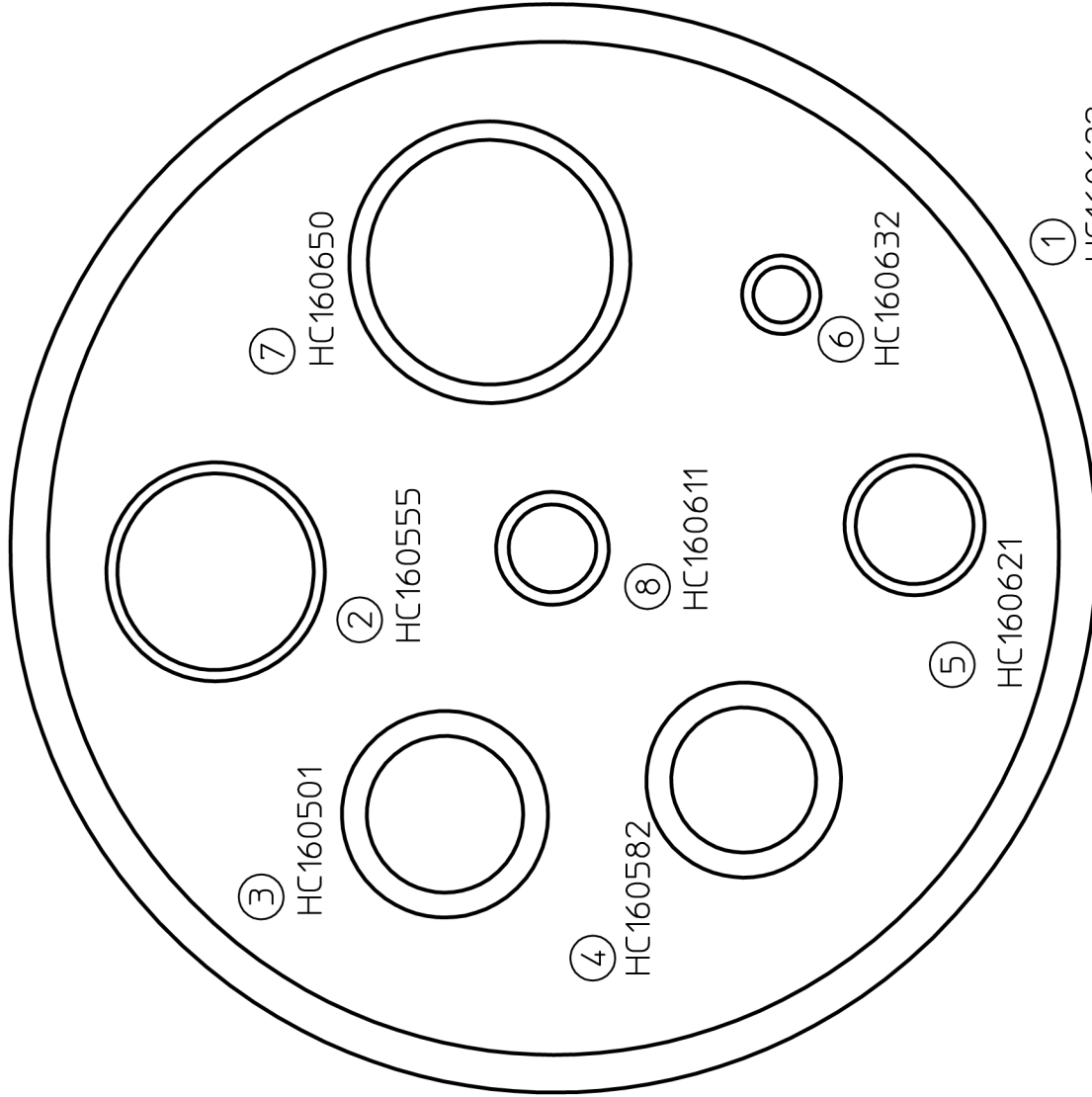

O-RING CHART

PH.NO. 309-755-4553

H.C.DUKE & SON, LLC