



**H. C. DUKE & SON, LLC**

2116 - 8th Avenue • East Moline, Illinois 61244

**OPERATOR'S MANUAL**  
with Illustrated Parts List



**Twin Twist  
Soft Serve Freezer  
Models**

**GEN-103**

184583— 4/18



**Operator's Manual  
for the  
Soft Serve Twist Freezer  
Model GEN-103**

# SAFETY FIRST!

Follow these four steps to safety ....

## 1. Recognize Safety Information .... Look for this safety alert symbol throughout this manual.



When you see this symbol on your freezer or in this manual, be alert to the potential for personal injury. Follow recommended precautions and safe operating practices.

## 2. Understand Signal Words ....



The signal words — DANGER, WARNING and CAUTION — are used with the safety alert symbol (DANGER decals on the freezer may or may not have the safety alert symbol, but the message is the same). Decals with the words DANGER, WARNING, or CAUTION appear on the freezer. DANGER identifies the most serious hazard. Decals with the words DANGER or WARNING are typically near specific hazards on the freezer. General precautions are listed on CAUTION safety decals.

In this manual, CAUTION messages with the safety alert symbol  call attention to safety messages.

## 3. Follow Safety Instructions ....



Read and understand all safety messages in this manual and on your freezer. Take notice of the location of all decals on the freezer and keep the safety decals in good condition. Check them periodically and replace missing, damaged, or illegible safety decals. The safety decals must remain in place and be legible for the life of the freezer. If you need new decals, use the information and illustrations on pages iv and v of this manual to identify the decal and call or write to H.C. Duke & Son, LLC.

**DO NOT** attempt to operate the GEN-103 Twin Twist Soft Serve Freezer until you read and understand all safety messages and the operating instructions in this manual.

# SAFETY FIRST!

## 4. Definitions ....

---

**Trained person (or Operator):** A person who has been trained in the basic operation of the freezer. This person is knowledgeable in operation of machine startup, stopping, filling, and basic cleaning, disassembly, washing, and sanitation of the freezer.

**Freezer Technician:** A person who has been trained by a factory representative, or an experienced and qualified service person, to perform more complicated operations such as freezer installation, maintenance repairs, component replacement, is aware of hazards associated with electricity, moving parts, and takes necessary steps to protect against injury to themselves and other people.

## 5. Operate Safely ....

---

**IMPORTANT:** Store Managers, owners, and supervisors must be aware of staff capabilities and that they do not perform freezer operations outside their level of knowledge or responsibility.



**DO NOT** allow untrained personnel to maintain or service this freezer. Failure to follow this instruction may result in severe personal injury. **DO NOT** operate the freezer until all service and access covers are secured with screws. **DO NOT** attempt to repair the freezer until the main power supply has been disconnected. Some freezers have more than one disconnect switch. Contact your IDQ authorized service representative or H.C. Duke & Son, LLC Service Department for original equipment parts.

## 6. Caution ....

---



- This Freezer is to be operated by trained persons. The Dispense feature, if used by public in self-serve applications, shall be monitored by trained persons able to assist people with physical, sensory or mental impaired capabilities.
- Children should not be allowed to play around this equipment.
- Do not store explosive substances such as aerosol cans with a flammable propellant in freezer.
- This appliance is not designed for outdoor weather conditions and shall not be exposed to rain.
- Do not wash machine with power sprayer. Do not install machine next to a power sprayer where splash of freezer can occur.
- Machine is designed for use in areas of normal atmosphere. It is not to be used in areas subject to explosion-proof standards.

## Safety Decal Locations

Do not attempt to operate the freezer until all safety precautions and operating instructions in this manual are read and understood.

Take notice of all warning, caution, instruction and information decals (or labels) on the freezer as shown in the figure on the next page. The labels have been put there to help maintain a safe working environment.

The labels have been designed to withstand washing and cleaning. All labels must remain legible for the life of the freezer. Check labels periodically to be sure they can be recognized as warning labels.

If it is necessary to replace any label, please contact H.C. Duke & Son, LLC. When ready to order you will need to determine the (1) part number, (2) type of label, (3) location of label, and (4) quantity required, and include a return shipping address.

For factory service assistance, contact H. C. Duke & Son, LLC, Service Department by phone or FAX:



Phone: (309) 755-4553

(800) 755-4545

FAX: (309) 755-9858

E-mail: [service@hcduke.com](mailto:service@hcduke.com)

(The decals on the next page are numbered 1, 2, 3, and 4. Those numbers correspond to the numbers in the table below. The table provides the part number, description, and quantity for each decal.)

No.	Part No.	Description
1	HC165025	Decal-Beater Warning (1)
2	HC165246	Decal-Pressurized System (3)
3	HC165126	Decal-Panel Removal Warning (1)
4	HC165048	Decal-Warning Rotating Parts (2)

# Safety Decal Locations

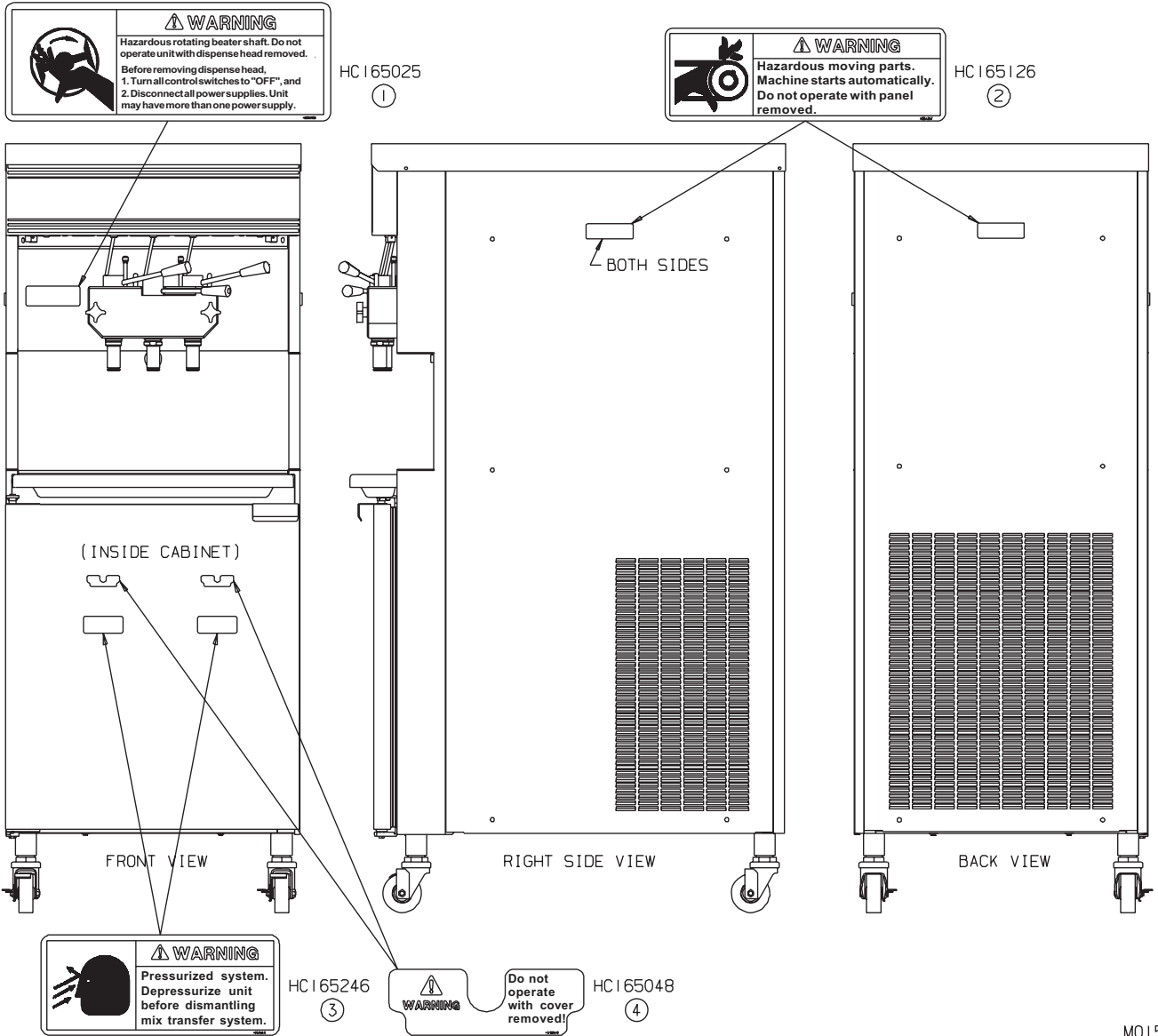

M01584

# Table of Contents

Safety Decal Locations .....	iv
Safety Decal Locations .....	v
<b>1 Introduction .....</b>	<b>1</b>
<b>2 Note to Installer.....</b>	<b>1</b>
2.1 Uncrating and Inspection.....	2
2.2 Installation .....	3
2.3 Electrical Requirements.....	3
2.4 Electrical Connections.....	4
<b>3 Specifications .....</b>	<b>5</b>
3.1 Particulars.....	5
3.2 Dimensions.....	6
3.3 Data Plate.....	6
3.4 Reference Information .....	7
3.5 Installation Date.....	7
3.6 WEEE (Waste Electrical and Electronic Equipment).....	7
<b>4 Virtual Quality Management System (VQM).....</b>	<b>8</b>
<b>5 Part Names and Functions.....</b>	<b>10</b>
<b>6 Operator Controls .....</b>	<b>16</b>
<b>7 Operator Display Menus .....</b>	<b>18</b>
<b>8 Disassembly and Cleaning.....</b>	<b>22</b>
8.1 Cleaning Accessories .....	23
8.2 Disassembly Instructions .....	24
8.3 Cleaning Instructions.....	26
8.3.1 Cleaning and Lubricating - MTS Assembly .....	29
<b>9 Assembly .....</b>	<b>30</b>
<b>10 Start-up Instructions .....</b>	<b>34</b>
10.1 Sanitizing.....	34
10.2 Priming .....	35
10.3 Dispensing Product.....	36
<b>11 Closing Procedures .....</b>	<b>37</b>
11.1 Draining Product.....	37
11.2 Night Switch Operation .....	38
<b>12 General Information .....</b>	<b>39</b>
12.1 Dairy Queen® Mix .....	39
12.2 Checking the Frozen DQ® Product .....	39
12.3 Product Temperature .....	40
12.4 Overrun .....	40
12.5 Overrun Adjustment.....	41
12.6 Rerun.....	41
12.7 Overrun Chart.....	42

13 Routine Maintenance .....43  
 14 Troubleshooting Tables .....49  
     14.1 MTS Troubleshooting Tables .....53  
 15 VQM Error Codes .....55

## PART II

# Replacement Parts

### Table of Contents

Figure 1 Head Assembly .....1  
 Figure 2 Beater Shaft Assembly .....2  
 Figure 3 MTS—RMT Hose Assembly.....3  
 Figure 4 1 Ph Mix Transfer System — RMT.....4  
 Figure 5 3 Ph Mix Transfer System — RMT.....6  
 Figure 6 Cabinet Parts .....8  
 Figure 7 Spigot Switch Assemblies .....9  
 Figure 8 Capacitor & Relay Box.....9  
 Figure 9 Switch Box .....10  
 Figure 10 Panel Breakdown .....12  
 Figure 11 Air Cooled Side/Back View .....14  
 Figure 12 Water Cooled Side/Back View .....16  
 Figure 13 Gear Reducer .....18  
 Figure 14 Evaporator Mix Tube Assembly.....19  
 Figure 15 Air Cooled Remote Condenser .....20  
 Accessories .....21  
 O-Ring Chart .....23



# 1 Introduction

---

The GEN-103 Freezer is designed to produce DQ frozen soft serve ice cream or DQ yogurt, with a product serving temperature of 18 to 19°F (-8 to -7°C). If such products are prepared from powdered concentrate, they should be precooled to 40°F (4°C) prior to introduction to the freezer. Use of other products in this machine is considered misuse (see Warranty.)

This manual has been prepared to assist in the training of personnel on the proper operation and general maintenance of your Duke freezer.

Your freezer will not compensate for or correct any assembly or priming errors made during the initial start-up. Therefore it is extremely important to follow the assembly and priming procedures detailed in this manual.

Be sure all personnel responsible for equipment operation completely read and understand this manual before operating the freezer. When properly operated and maintained, your freezer will produce a consistent quality product.

If you require technical assistance, please contact your local authorized H.C. Duke & Son, LLC service company:

Name \_\_\_\_\_

Address \_\_\_\_\_

Phone \_\_\_\_\_

or H.C. Duke & Son, LLC Service Dept.  
for factory service assistance.

Phone: (309) 755-4553



(800) 755-4545

Fax number: (309) 755-9858

E-mail: [service@hcduke.com](mailto:service@hcduke.com)

# 2 Note to Installer

---

**This freezer must be installed and serviced by a service technician in accordance with the installation instructions.**

**After installation the warranty registration card must be completed and returned to validate warranty.**

## 2.1 Uncrating and Inspection

**CAUTION**

**Be sure to properly support the machine when removing bolts and installing legs or casters.**

When the unit is received and while the carrier is still present, inspect the shipping carton for any damage that may have occurred in transit. If the SHOCKWATCH® label indicates red and/or the carton is broken, torn, or punctured

note the damage on the carrier's freight bill and notify the carrier's local agent immediately. Also note on the freight bill

1. 1. Remove the carton from the pallet, and move the machine as close as possible to the permanent location.
2. 2. Remove the shipping bolts on the bottom of the freezer (figure 2-1) and install either the legs or casters (figure 2-2).

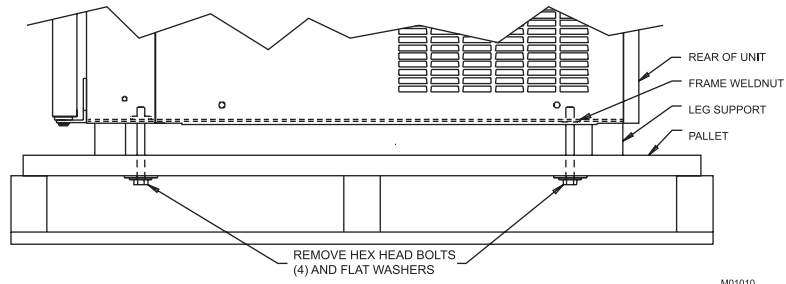

**Figure 2-1 Machine bolted to Shipping Base**

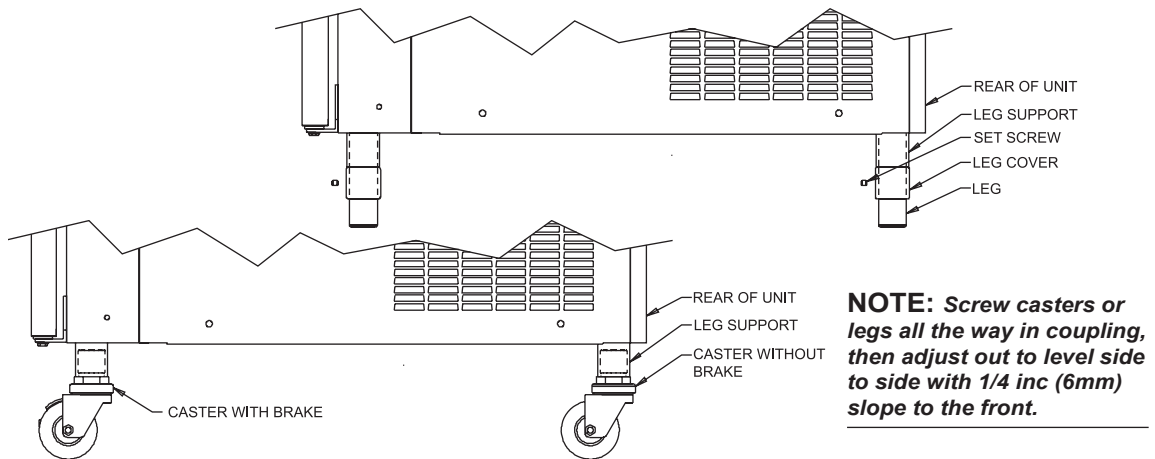

**Figure 2-2 Installing Mounting Legs or Casters**

— continued

## 2.2 Installation



**CAUTION**  
All materials and connections must conform to local requirements and be in compliance with the National Electrical Code (NEC).

1. 1. This freezer is designed for indoor use and must be protected from outdoor weather conditions.
2. 2. Where codes permit, we recommend that the freezer be installed on casters and have flexible water and electrical connections for service and cleaning ability.
3. 3. **All models** require a minimum 6 inch (15cm) clearance on either the side panels and 0 inch in the rear or 6 inch (15cm) in the rear and 0 inch on the side panels for adequate ventilation. Freezers require a least 24 inches (61cm) clearance above the top panel and be free of obstructions. Anything blocking ventilation of the freezer (including cone dispensers) will reduce the efficiency of the freezer.
4. 4. **Water cooled** double models will require a 1/2" MPT water inlet and water waste connection. Both water condensers are tied together so that one water inlet and one water waste is all that is required. The connections are found on the bottom under the compressor mounting area and are clearly tagged - "Water Inlet" and "Water Waste". A manual shut-off valve should be installed in the water inlet line at the time of installation. The water pressure must be between 35-140 psig (241-965kPa) for proper operation.
5. 5. Place the freezer in the final location and level the machine by adjusting the legs or casters so that the unit is level side-to-side, and the front is approximately 1/4" lower than the rear, to allow proper drainage of the freezing cylinder.
6. 6. **Water Cooled** Do not allow freezer to be in ambient where air temperature goes below 0°C (32°F), the freezing temperature of water.
7. 7. **Water consumption** increases if temperature of entering water is above 20°C (65°F)

## 2.3 Electrical Requirements



**CAUTION**  
To prevent accidental electrical shock, a positive earth ground is required.

1. 1. Always verify electrical specifications on the data plate of each individual freezer. Data plate specifications will always supersede the information in this manual. (See Figure 3-2)
2. 2. Supply voltage must be within  $\pm 10\%$  of voltage indicated on the nameplate. Also, on three-phase systems, voltage between phases must be balanced within 2%. (More than a 6 volt difference between any two voltage measurements at 208-230 volts indicates a possible imbalance.) Request your local power company to correct any voltage problem.
3. 3. An easily accessible main power disconnect must be provided for all poles of the wiring to the freezer.

## 2.4 Electrical Connections



**CAUTION**  
To prevent accidental electrical shock, a positive earth ground is required.

***Important!***

***A positive earth ground is required for electronic VQM system to operate correctly.***

1. Double freezers with two compressors require one power supply for each side of the freezer. Each side of the freezer operates independently.
2. Check the data plate for fuse size, wire ampacity, and electrical specifications. (See Figure 3-2)
3. Refer to the wiring diagram



**WARNING**

**Warning:** When installing the machine, insert an all pole disconnect, adequately sized according to freezer nameplate marking with electrical contact spacing of 3mm minimum. This should be within sight of the freezer.

provided for proper power connections.

4. Electrical connections are made in the junction boxes located mid-level behind the left side panel.

***Important***

***Set switch next to the connection box "UP" for 220-230v or "DOWN" for 208-219V. Failure to set switch to proper voltage will cause damage to the electrical components and will void all warranties.***

5. Use a flexible connection when permissible.
6. Beater Shaft Rotation Freezers are designed for clockwise rotation when viewed from front of freezer. 1ph machines are prewired for proper rotation. On 3phase machines, phase wires to freezer should be connected to produce proper beater rotation. This is to be done by a freezer technician.

## 3 Specifications

### 3.1 Particulars

Always check and verify voltage and amperage on the data plate located on the back panel of each freezer.

#### **GEN-103**

Width-in./cm	26/66
Height-in./cm	67.5/171
Depth-in./cm	36.5/93
Weight-lbs./kg	847/384
Compressor (2)	2 H.P. /19000 BTUH 2.2 kw (Motor) 3.2 kw (Cooling)
Compressor Cabinet (1)	1/6HP/650BTUH 125w (Motor) 190w (Cooling)
Beater Motor (2)	2 H.P./1.5 kw
Refrigerant	404a
Charge*	3.75 lb/1.7 kg
Mix Container** (2)	24 Qts./22.7 Liters
Cylinder (2)	4 Qts./3.8 Liters

ACR

Noise: The Steady acoustic pressure level, for both air cooled and water cooled freezers, is less than 70dB(A).

Water Cooled units: Water consumption increases if temperature of entering water is above 20°C (65°F)

\*Approximate for each side. See nameplate for actual charge.

\*\* Do not add mix above line marked on side of mix tank wall.

### 3.2 Dimensions

The dimensions of the GEN-103 are provided in Figure 3-1, below.

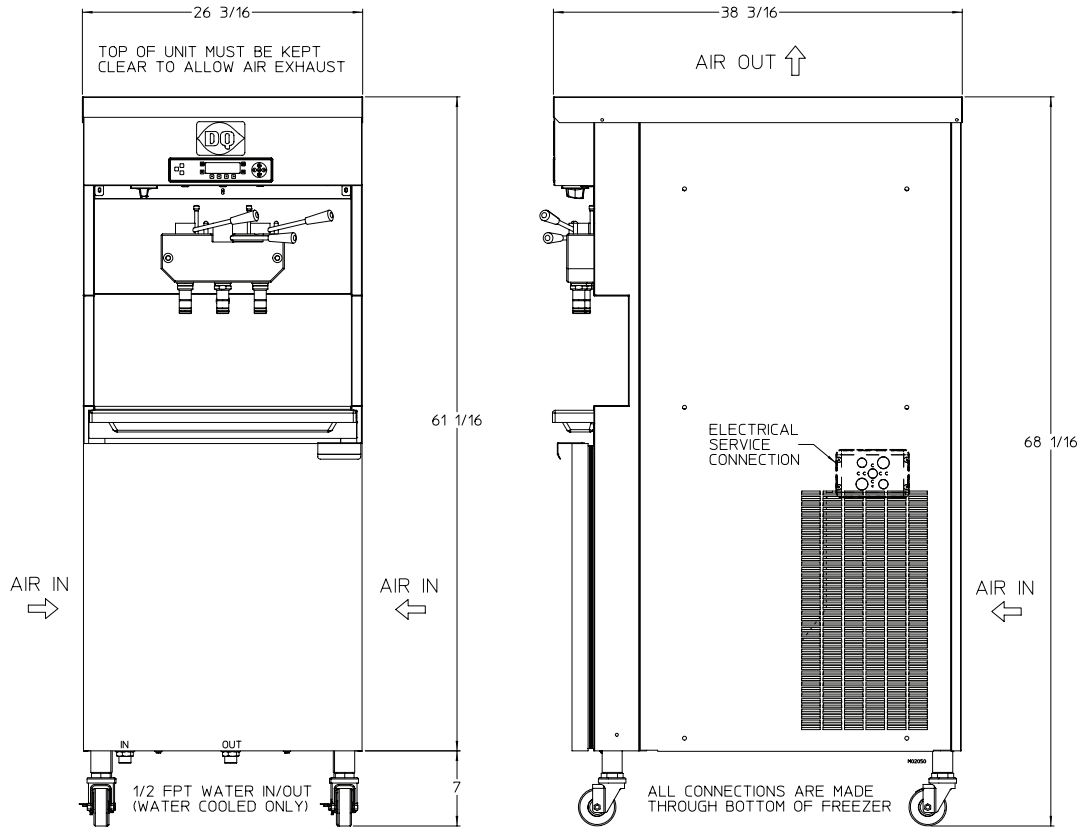

Figure 3-1

### 3.3 Data Plate

The data plate provides important information that the operator should record and have available for parts ordering, warranty inquiries, and service requests.

Figure 3-2 Data Plate

**3.4 Reference Information**

**Write in  
Reference  
Information *HERE!***



Fill in the following information below as soon as you receive the GEN-103. (The item numbers—encircled, below—correspond with the callout numbers above.)

**IMPORTANT: Complete for reference:**

- 1.) Model Number: \_\_\_\_\_
- 2.) Serial Number: \_\_\_\_\_
- 3.) Electrical Spec: Voltage \_\_\_\_\_  
Phase \_\_\_\_\_ Hertz \_\_\_\_\_
- 4.) Minimum Circuit Ampacity: \_\_\_\_\_
- 5.) Maximum Fuse Size: \_\_\_\_\_

**3.5 Installation Date**

Installation Date \_\_\_\_\_

Installed by \_\_\_\_\_

Address \_\_\_\_\_

\_\_\_\_\_

Phone \_\_\_\_\_

**3.6 WEEE (Waste Electrical and Electronic Equipment)**

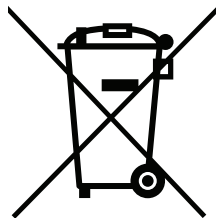

In conformity with EU 2002/96/EC, this freezer, at the end of life cycle, is not to be discarded with normal urban waste. Instead, it is the user's responsibility to dispose of this product by returning it to a collection point designated for the recycling of electrical, electronic components and separation of reclaimable, recyclable materials. Contact your local distributor or authority for correct disposal.

## 4 Virtual Quality Management System (VQM) Terminology

- Beater Run: ..... This D.O.B. timer used to delay the beater motor after the refrigeration shuts down. Beater Run Range: 0 to 10 seconds
- Demand Run Comp:..... The D.O.B. timer used to delay the compressor when product is being drawn. Demand Run Comp. Range: 0 to 12 seconds
- Differential/ Hyst: ..... Symbolizes the differential setting. Differential range: 7 to 20°F i.e. if your cut in is at 18°F and your Differential is at 10°F your unit will cut out at 8°F
- Dual Diff:..... The differential used when product is being drawn out of the center spigot. Dual Differential range: 7 to 20°F
- Idle:..... When the unit is cycling on temperature and no product is being dispensed
- Idle Run Comp:..... Delay on break (D.O.B.) timer used for the compressor when the unit is in idle mode/no product being drawn. Idle Run Comp. Range: 0 to 20 seconds
- Lock outs: ..... Allows the function of a specific feature/button to be temporarily disabled to deter un-necessary usage of that feature.
- Main P.C. Board:..... Main Control board for the unit, housed behind the trim strip panel. This board has many connectors on it and is responsible for the main operations of the unit.
- Membrane Switch:..... The black Electro Freeze decal visible on the front of the unit, which houses the hidden operator, technician, soft, and hard keys used to navigate the menus
- Relay Board..... A control board located in the main electrical control box. This Board contains no software, only solid state control relays to operate system components.
- Single Diff: ..... The differential used when product is being drawn out of one barrel. Single Hysteresis range: 7 to 20°F
- Slope/Demand Slope: ... Utilizes a function within the system to watch the temperature change as the unit freezes a barrel. If utilizing the slope feature and the unit sees a lack of temperature change during freeze down, the unit will cycle off. This will prevent a freeze up condition due to a long run time. Demand Slope range: 0 to -0.2

## 4

**Virtual Quality Management System (VQM)  
Terminology (continued)**

---

Temp. Comp.: ..... Temperature compensation, utilized when the slope feature is turned on. It prevents the system from seeing the slope temperature curve until a determined temperature is reached. Once that temperature has been reached then the system will examine the curve and shut down if necessary.  
Temp. Comp. Range: -10 to 22°F

Temperature Offset: ..... A function that allows temperature adjustment to the operator. Adjustable from 1-9 and 5 being neutral/no change, Lower than 5= colder and greater than 5=warmer

Transducer: ..... An electronic control used to measure the cylinder pressure for mix pump operation.

U.I./ User Interface: ..... The board that lies directly behind the membrane switch on the front panel. This board houses the LED screen that displays the menus and operations. The membrane switch is connected to this board via a ribbon cable. This board also has its own software.

# 5 Part Names and Functions

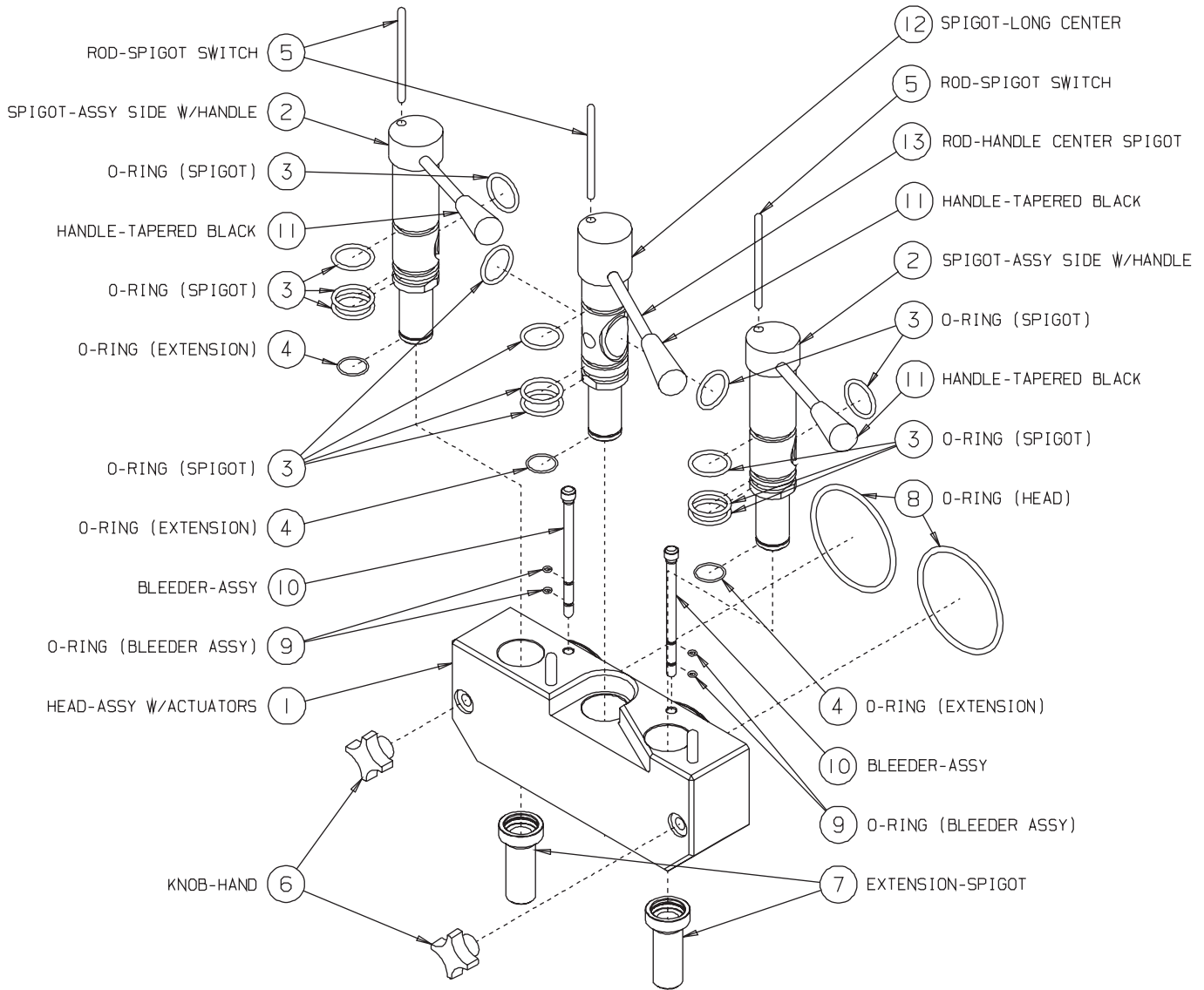

M01586

**Figure 5-1 Head Assembly**

## 5 Part Names and Functions (continued)

*The following descriptions apply to figure 5-1. The number preceding the part name corresponds to the number in the figure.*

- |  |   |
|--|---|
| <p>1.) <b>HEAD:</b><br/>Encloses the freezing cylinder and provides an opening for product to be dispensed. NOTE: Beater motors will not operate with the head removed from the freezer.</p> | <p>10.) <b>PLUG-AIR BLEED (BLEEDER ASSY.):</b><br/>Seals the air bleed opening in the head when closed. Allows excess air to be removed from the cylinder when priming.</p> |
| <p>2.) <b>SPIGOT - ASSEMBLY SIDE WITH HANDLE (STAINLESS STEEL):</b><br/>Seals the product opening in the head when closed. Allows product to flow when open.</p>                             | <p>11.) <b>HANDLE-TAPERED BLACK (PLASTIC):</b><br/>Black plastic handle that fits onto the stainless steel handle.</p>  |
| <p>3.) <b>O-RING - SPIGOT:</b><br/>Seals the spigot in the head. Must be lubricated to seal and slide properly.</p>  | <p>12.) <b>SPIGOT-LONG CENTER WITHOUT HANDLE (STAINLESS STEEL):</b><br/>Seals the product opening in the dispense head when closed. Allows product to flow when open.</p>   |
| <p>4.) <b>O-RING - SPIGOT EXTENSION:</b><br/>Holds the extension on to the spigot.</p>   | <p>13.) <b>ROD-HANDLE CENTER SPIGOT (STAINLESS STEEL):</b><br/>Opens and closes the spigot to start and stop the flow of product from the freezer.</p>                      |
| <p>5.) <b>ROD - SPIGOT:</b><br/>Starts the freezer when dispensing. Must be in place before freezer will operate.</p>  |   |
| <p>6.) <b>KNOB-HAND:</b><br/>Secures the head to the freezing cylinder.</p>  |   |
| <p>7.) <b>EXTENSION - SPIGOT: (ACCESSORY)</b><br/>Extends the product opening down to shape the product as it is dispensed.</p>  |   |
| <p>8.) <b>O-RING - HEAD:</b><br/>Seals the head to the freezing cylinder. Must be lubricated.</p>  |   |
| <p>9.) <b>O-RING-AIR BLEED PLUG:</b><br/>Seals the air bleed plug in the head.</p>   |   |

## 5 Part Names and Functions (continued)

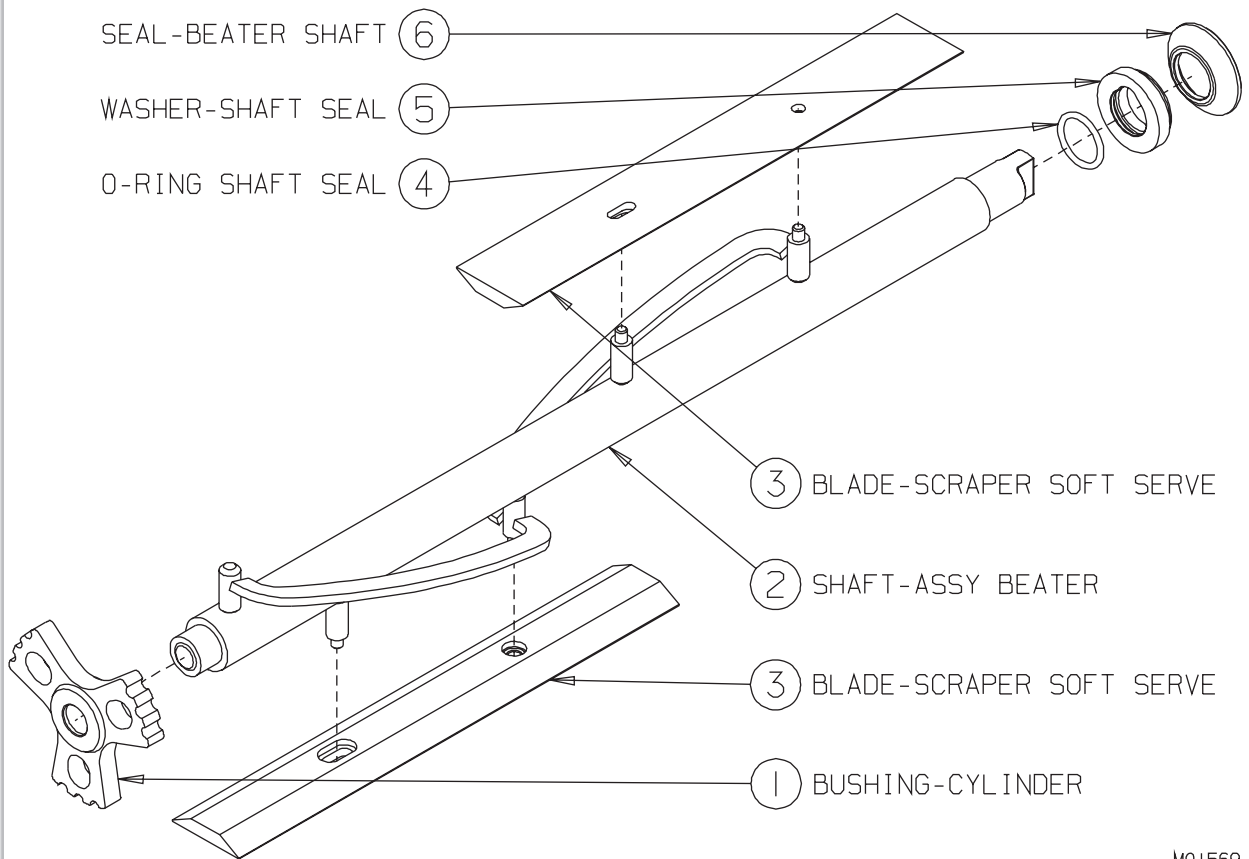

M01569

**Figure 5-2 Beater Shaft Assembly**

## 5 Part Names and Functions (continued)

---

*The following descriptions apply to figure 5-2. The number preceding the part name corresponds to the number in the figure.*

- 1.) **BUSHING - CYLINDER:**  
Holds the beater in place at the front of the cylinder.
- 2.) **SHAFT - BEATER:**  
Rotates in the freezing cylinder, blending air and mix as it ejects product.
- 3.) **BLADE - SCRAPER:**  
Scrapes the frozen product from the freezing cylinder wall
- 4.) **O-RING-SHAFT SEAL:**  
Seals the beater shaft to the shaft seal. Is inserted into the shaft seal washer. **Must be lubricated.**
- 5.) **WASHER-SHAFT SEAL:**  
Holds the shaft seal o-ring. **Lightly lubricate the side opposite the cup seal.**
- 6.) **SEAL(CUP)-BEATER SHAFT:**  
Seals the opening between the freezing cylinder and the beater shaft. Do not lubricate rubber cup portion.

## 5 Part Names and Functions (continued)

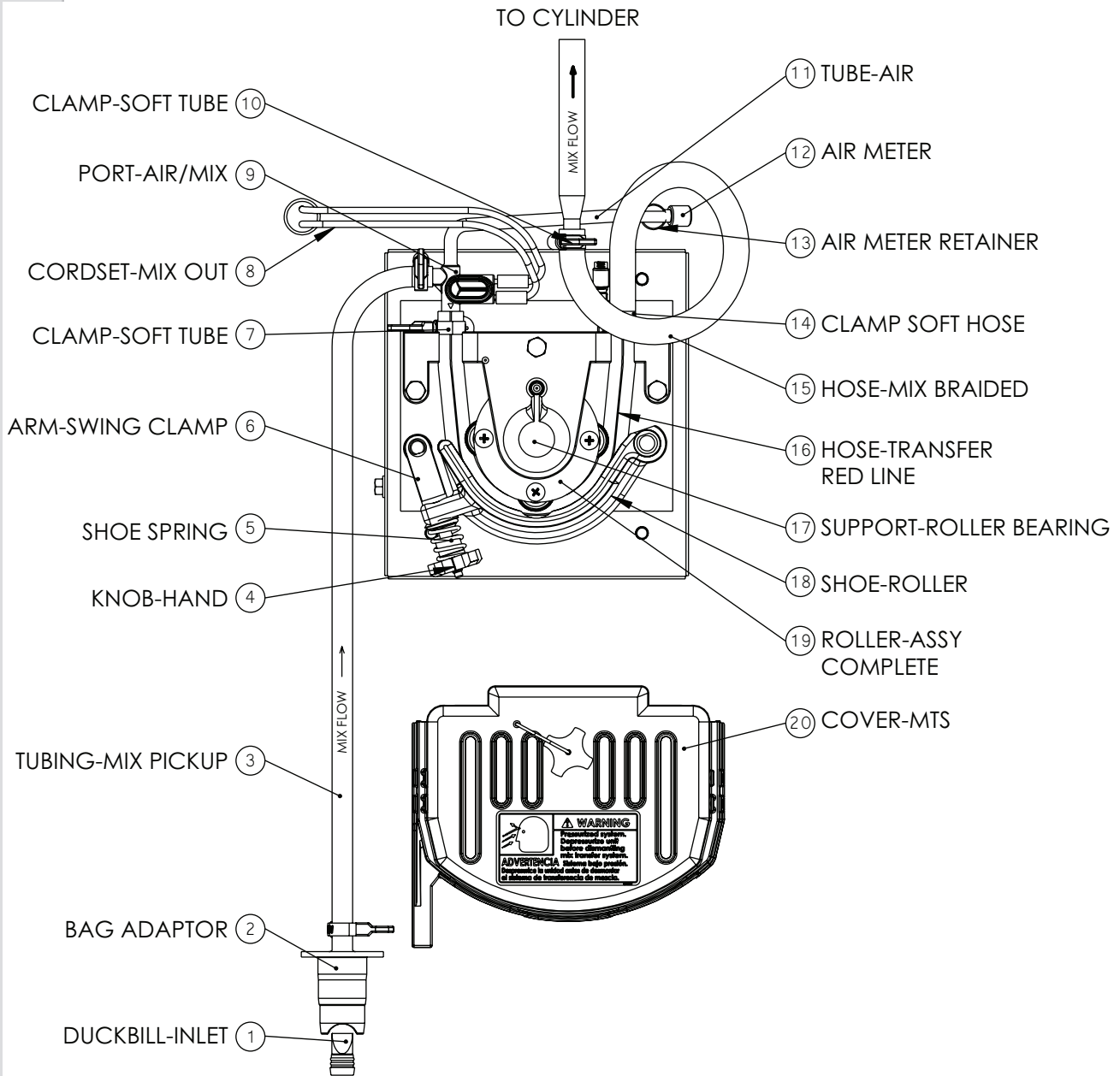

**Figure 5-3 Mix Transfer System (MTS)**

## 5 Part Names and Functions (continued)

*The following descriptions apply to figure 5-3. The number preceding the part name corresponds to the number in the figure.*

- |  |  |
|--|--|
| <p>1.) <b>DUCKBILL:</b><br/>A rubber check valve that prevents mix from falling back into the mix container.</p> | <p>14.) <b>CLAMP - ASSY. SOFT HOSE 5/8”:</b><br/>Prevents mating parts from leaking.</p>   |
| <p>2.) <b>ADAPTER - MIX BAG:</b><br/>Connects the mix inlet tube to the mix bag.</p>                             | <p>15.) <b>HOSE - ASSY. MIX BRAIDED:</b><br/>Connecting tube between the Mix Transfer System and the cylinder inlet.</p>           |
| <p>3.) <b>TUBE - ASSEMBLY MIX INLET:</b><br/>Carries mix from mix container to MTS.</p>                          | <p>16.) <b>HOSE - TRANSFER RED:</b><br/>Special “red-lined” hose that is squeezed by rollers to transfer mix to freezer.</p>       |
| <p>4.) <b>KNOB - HAND:</b><br/>Locks roller shoe in position.</p>  | <p>17.) <b>SUPPORT - ROLLER BEARING:</b><br/>Holds roller assembly in place.</p>   |
| <p>5.) <b>SHOE - SPRING:</b><br/>Holds clamp in place.</p>   | <p>18.) <b>SHOE - ROLLER:</b><br/>Provides an opening to insert the mix transfer hose. Squeezes transfer hose against rollers.</p> |
| <p>6.) <b>ARM - SWING CLAMP:</b><br/>Swings hand knob into position over roller shoe.</p>                        | <p>19.) <b>ROLLER ASSEMBLY COMPLETE:</b><br/>Squeezes mix/air through tubing to freezing cylinder.</p>                             |
| <p>7.) <b>CLAMP - ASSY. SOFT HOSE 5/8”:</b><br/>Prevents mating parts from leaking.</p>                          | <p>20.) <b>COVER - MTS:</b><br/>Protection against moving parts. Cover must be in place for the MTS to operate.</p>                |
| <p>8.) <b>CORDSET - SOFT TUBE:</b></p>   |  |
| <p>9.) <b>PORT - AIR/MIX:</b><br/>Blends air and mix as it flows into the transfer hose.</p>                     |  |
| <p>10.) <b>CLAMP - ASSY. SOFT HOSE 5/8”:</b><br/>Prevents mating parts from leaking.</p>                         |  |
| <p>11.) <b>TUBE - AIR:</b><br/>Provides connection for the air meter.</p>  |  |
| <p>12.) <b>AIR METER:</b><br/>Regulates the amount of air being drawn into the system.</p>                       |  |
| <p>13.) <b>RETAINER - AIR TUBE:</b><br/>Holds air meter tube in the “up” position.</p>                           |  |

## 6 Operator Controls

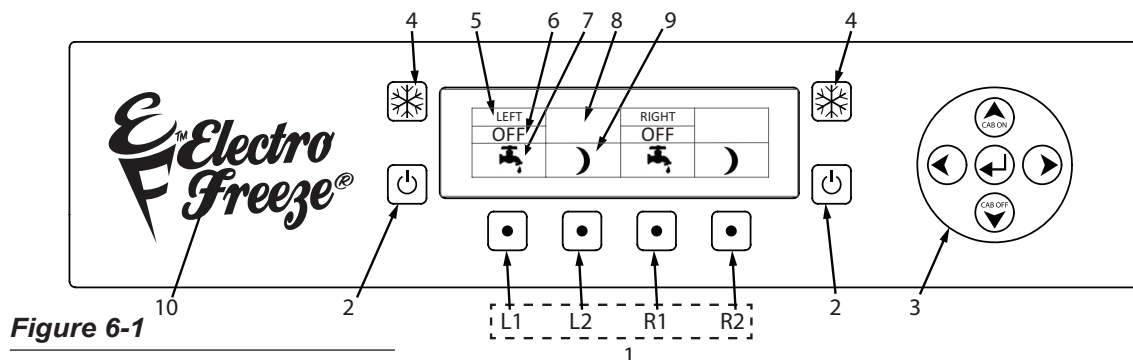

Figure 6-1

The following paragraphs describe the operator controls. Refer to Fig. 6-1 for numbered items in description. Note the left side controls operates the left side cylinder and hopper. Operation for right side controls is the same. The display window has three levels of display: Operators Menu, Technician Menu, and Factory Menu. The last two menus are restricted and reserved for use by qualified personnel.

**CAUTION**  
 Test operation of the head switch prior to placing the freezer in service. See Section 11, Routine Maintenance, Monthly.

NOTE: The dispense head must be in place before the freezer will operate.

### 1. Function Buttons (Four)

Pressing any of these buttons will activate the icon directly above in the display screen. Left side (L1 & L2), Right Side (R1& R2).

### 2. OFF Key

When this symbol is pressed, the left side of unit will shut off. The beater motor and compressor will not operate.

### 3. Navigation Pad (Up/Down = Cabinet ON/OFF)

Used to navigate the menu structure. Up/Down arrows are used to turn the cabinet on/off when both cylinders are off. Used by technicians for programming and setting changes. See Troubleshooting section for Operator accessible controls.

### 4. Freeze Symbol

When this symbol is pressed, the unit will enter the automatic freeze mode. Both the hopper and cylinder compressors will energize to refrigerate product to settings in program. Use this button for DAY mode operation to maintain product in “ready to serve” state.

## 6 Operator Controls (continued)

---

### 5. Left or Right side Control Indicator

---

Left indicates controls for left side cylinder and hopper. “Right” Indicates controls for right side of freezer cylinder and hopper.

### 6. Mode of Operation Indicator

---

There are three primary modes of operation:

**a. OFF** – This is the indicator when power is applied to freezer and when (OFF) button is pressed. In this mode, the refrigeration and beater motor will not operate.

**b. FRZ** – This is the indicator when Freeze button is pressed. In this mode, the freezer is in automatic freeze mode and both the beater motor and refrigeration will activate as needed. Use this position for dispensing product from freezer. Hopper will also be refrigerated as needed to maintain product below 41°F.

**Important: Do not use the  freeze position with water or sanitizer in the cylinder or hopper. The freezer will be damaged.**

**c. Night** – This is the indicator when Night button is pressed. In this mode, an energy-saving feature will activate and reduce product refrigeration. The freezer will automatically cycle to maintain temperatures in the cylinder and hopper below 41°F and keep product from deteriorating. Use this position when the freezer will not be in use for periods of more than one hour.

### 7. Wash or Clean Mode

---

Press the function button directly below icon to activate clean mode.

### 8. Information Window

---

This window is normally blank when unit is functioning properly. This window will give you indication when mix in hopper is low and other error messages. Refer to Troubleshooting Section of manual for details on error messages.

### 9. Standby Indicator

---

This is the indicator when Night button is pressed. In this mode, an energy-saving feature will activate and reduce product refrigeration. The freezer will automatically cycle to maintain temperatures in the cylinder and hopper below 41°F and keep product from deteriorating. Use this position when the freezer will not be in use for periods of more than one hour.

### 10. Hidden Operator Menu Key

---

Press this key to enter the operator menu to adjust the freezers settings.

## 6 Operator Controls (continued)

### 12 Power Switch See Figure 6-3

In the "ON" position, power is supplied to the beater motors. Use this position to operate the freezer. Select the "OFF" position for disassembly and cleaning. See Operators Display Menu for use of this switch in recording cleaning cycles.

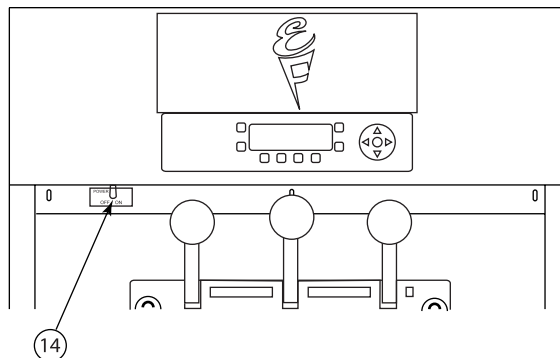

Figure 6-3

## 7 Operator Display Menus

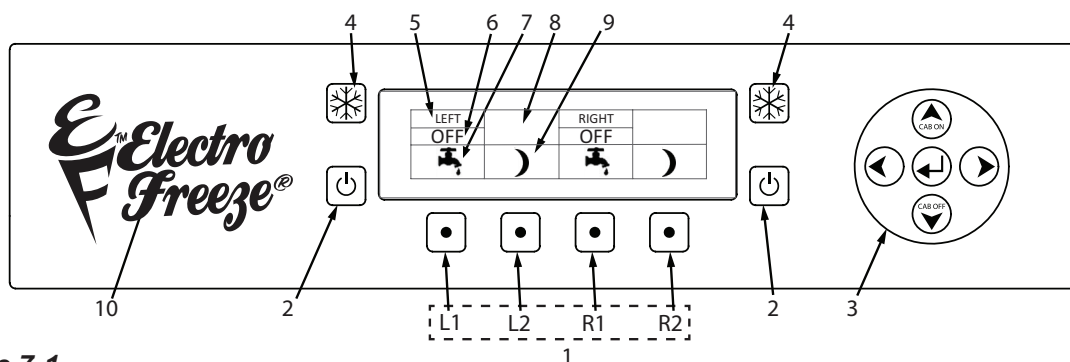

Figure 7-1

To Enter the Operator Menu, push and hold the hidden key (11) under the F for 3 seconds (figure 7-1).

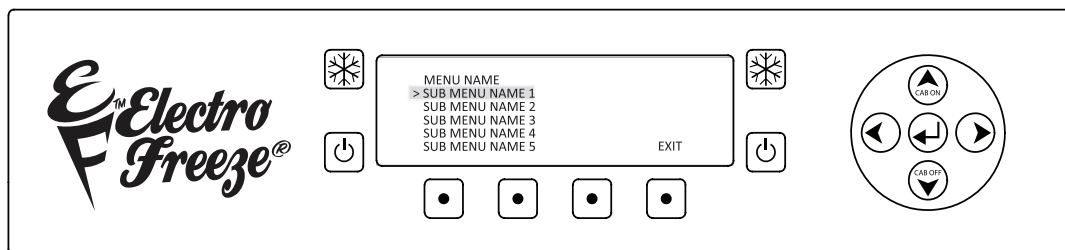

Figure 7-2

The operator menu will show up on the screen (figure 7-2). The cursor will highlight the selected sub-menu (i.e. Basic Setting, Actual Temps, etc.), use the Arrow Buttons to move the cursor up or down to the desired sub-menu. Once the desired menu is highlighted, in this example we will use Basic Settings, press the select (↵) button to enter the sub-menu. Product Type and Temperature Offset will be shown for left and right barrel. Use the Arrow Buttons to move the cursor to highlight the value to be changed, once highlighted press the select button and the cursor will now be blinking. While the cursor is blinking the value may now be changed using the left or right Arrow Buttons, once you have reached the desired setting press select (↵) one more time, the cursor will now stop blinking, this indicates that the value change has been stored. Follow these steps to change any other desired settings, once complete you may use the far right Function button to exit the operator menu or just wait and the menu will time out and return to the Home screen.



## 7 Operator Display Menus (continued)

### Statistics Cont.

Center Spigot	
Spigot Hours	Left & Right Barrel
C Spigot Hours	
Comp. Starts	Left & Right Barrel
Comp. Hours	Left & Right Barrel
Beater Starts	Left & Right Barrel
Beater Hours	Left & Right Barrel
Cab Comp. Starts	
Cab Comp. Hours	
Pump Starts	Left & Right Barrel
Pump Hours	Left & Right Barrel

**Lockouts:** Allows the operator to lock out the clean, freeze, and night function so that on the home screen when the button is pressed the unit will not react.

### Information Shown

Freeze Mode	<b>Y or N</b>
Clean Mode	<b>Y or N</b>
Cab Only Mode	<b>Y or N</b>
Cones Left	5

**Screen Settings:** Operator can turn on or off the following functions:

Display Cabinet Temperature	<b>Y or N</b>
(Will or will not display Cabinet temp. on home screen)	
Alternate Moon	<b>Y or N</b>
Beep Function	<b>Y or N</b>
(unit will or will not beep when a button is pressed)	
Hide Clock Error	<b>Y or N</b>

**Date/Time:** Allows user to set the Real Time Clock and current date in the unit.

**Last Clean:** Displays the Last time the unit has been cleaned

**Software Versions:** Has current software version numbers for both the U.I. and

Main board	
Main	_____
U.I.	_____
Model	GEN
Cyl Count	2
Compressors	2
Hopper	Y or N
Cabinet	Y or N
Product Table	GEN or SLX

Cabinet Temperature Map for user adjustment. User will only see 1 through 9 but the table below shows the differences with each number change. **6 is default setting**

## 7 Operator Display Menus (continued)

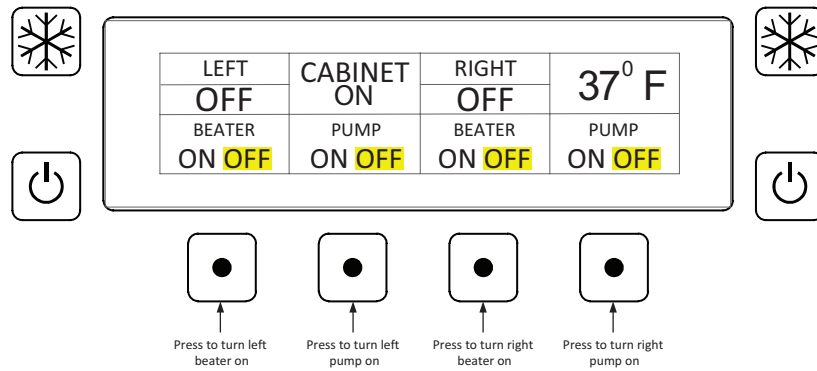
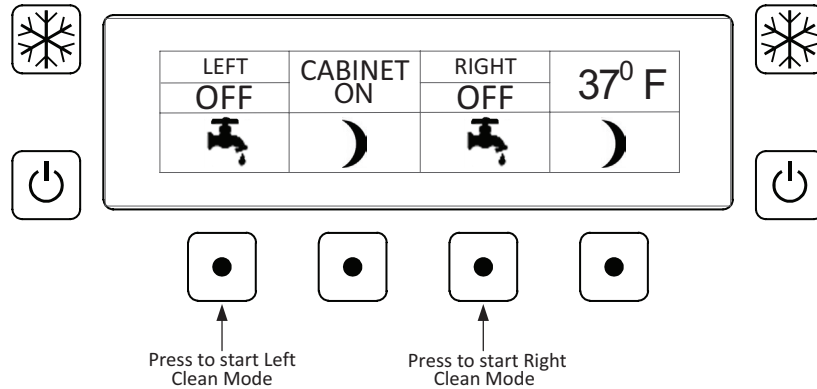

### Night Mode Operation

As pictured below, the Soft Key located below the image of the Moon will allow the machine to be switched into NIGHT refrigeration mode. This feature is used at the closing of the day's business to hold the product at safe storage temperatures but not in a frozen state.

**PLEASE NOTE: Dairy Queen allows the Night mode to be used for 72 Hours before the machine MUST be disassembled and cleaned per instructions in this manual.**

During the use of the NIGHT mode, the computer will monitor the system and maintain a mix holding temperature of 36°F (2.2°C) or below. The beater will cycle throughout this mode to maintain product circulation through the dispensing head.

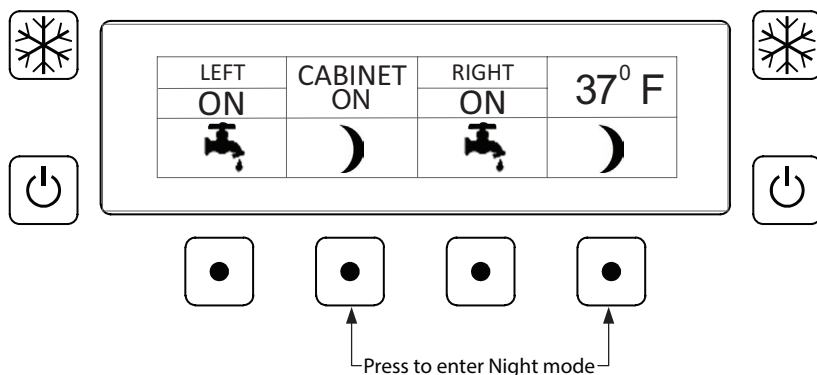

## 8 Disassembly and Cleaning

### Safety Information

This freezer uses pressure to assure consistent product quality. It is important for your safety that the freezer is depressurized slowly and completely whenever the freezer is to be drained, disassembled, cleaned, or serviced. The safety instructions in this manual will remind you when to check to make sure the freezer is depressurized. When you see this CAUTION statement

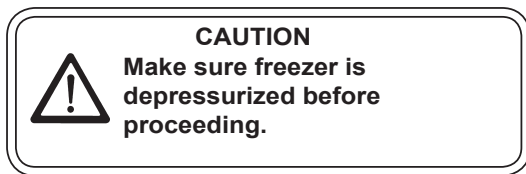

the following steps should be taken:

1. Using the buttons L2 & R2 on the control panel be sure both MTS pumps are in the "OFF" position.
2. Turn the control pad "OFF" and then

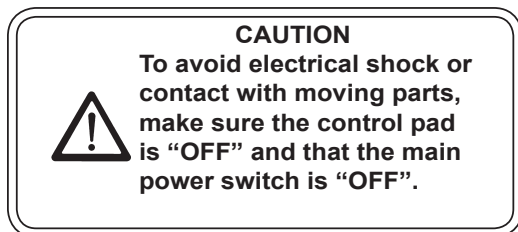

turn "OFF" the main power switch.

3. Place a clean bucket under the dispense head.
4. **Slowly** open the spigots, allowing any pressurized cleaning solution or air to escape. If there is product in the freezer refer to Section 9, Closing Procedures, 9.1 Draining Product.
5. Remove the spigot switch rods and open the spigots completely.
6. Inside the refrigerated cabinet, remove the MTS cover, loosen the shoe clamp hand knob, swing back the shoe clamp and swing open the roller shoe on both mix transfer systems.

Following these steps will assure that the system is depressurized.

***It is important that the freezer be disassembled, washed, lubricated and sanitized before operation.***

The cleaning and sanitizing instructions explained in this manual are required to maintain a clean, sanitary freezer. The freezer should be disassembled, cleaned, reassembled, lubricated and sanitized daily to ensure the best possible product quality and freezer operation.

Persons assembling, cleaning or sanitizing the freezer must first wash and sanitize hands and forearms with an approved sanitizer.

## 8.1 Cleaning Accessories

The following accessories are necessary for cleaning, sanitizing, and disassembly/assembly (Figure 8-1):

- |   |   |
|---|---|
| <p>1.) <b>HC158009 BRUSH<br/>HC158012 HANDLE:</b><br/>4 inch diameter and 36 inch handle used to clean the shake cylinder.</p> <p>2.) <b>HC158019 BRUSH:</b><br/>9/16 inch diameter 30 inch overall length used to clean drain tube, the mix feed tube in the ceiling of the cabinet and the pickup tube.</p> <p>3.) <b>HC158018 BRUSH:</b><br/>7/16 inch diameter 12 inch overall length used to clean transfer hose, braided hose, and the air relief opening in the dispense head.</p> <p>4.) <b>HC158026 BRUSH:</b><br/>1 inch diameter 12 inches long used to clean the disassembled shaft seal and bushing.</p> <p>5.) <b>HC158037 BRUSH:</b><br/>1/4 inch diameter 18-1/2 inches overall length used to clean the air meter hose, the small hole in the back of the dispense head and small parts.</p> | <p>6.) <b>HC169374 TOOL - O-RING REMOVAL:</b><br/>Aids in removing o-rings from plunger, head, air relief plug, and spindle.</p> <p>7.) <b>HC158000A LUBRICANT - LUBRI-FILM PLUS:</b><br/>Approved lubricant for moving parts and o-rings.</p> <p>8.) <b>HC196103 BOTTLE, WASH:</b><br/>Used to flush the hose cavity, roller assembly and plunger.</p> <p>9.) <b>HC115530 KIT - O-RING:</b><br/>Contains all o-rings and seals needing replacement on a regular basis. (not shown)</p> |
|---|---|

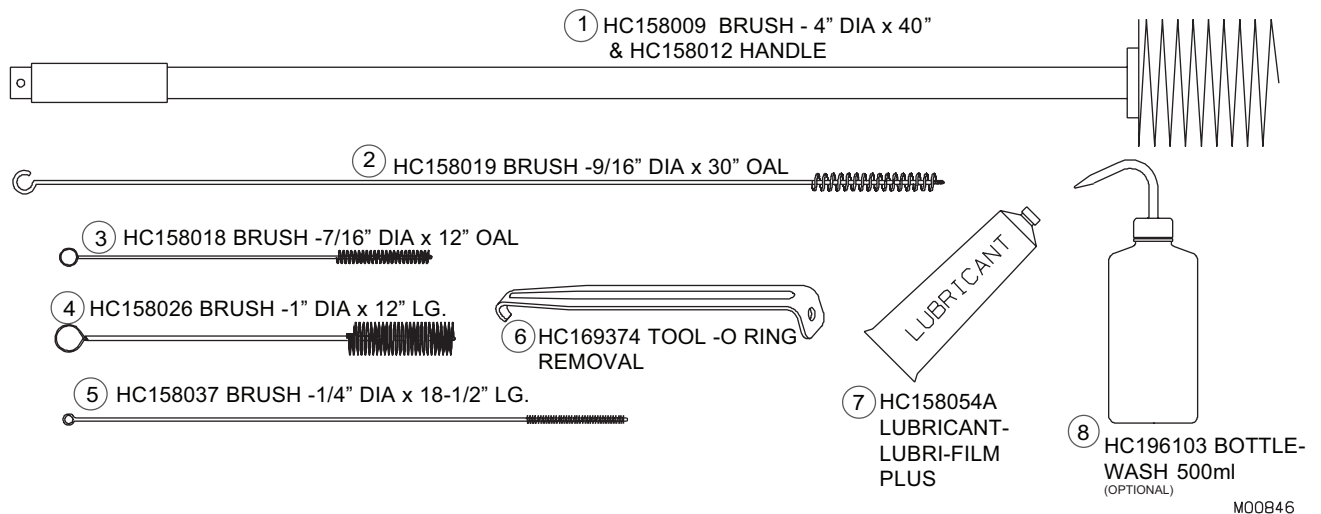

M00B46

**Figure 8-1 Cleaning Accessories**

## 8.2 Disassembly Instructions

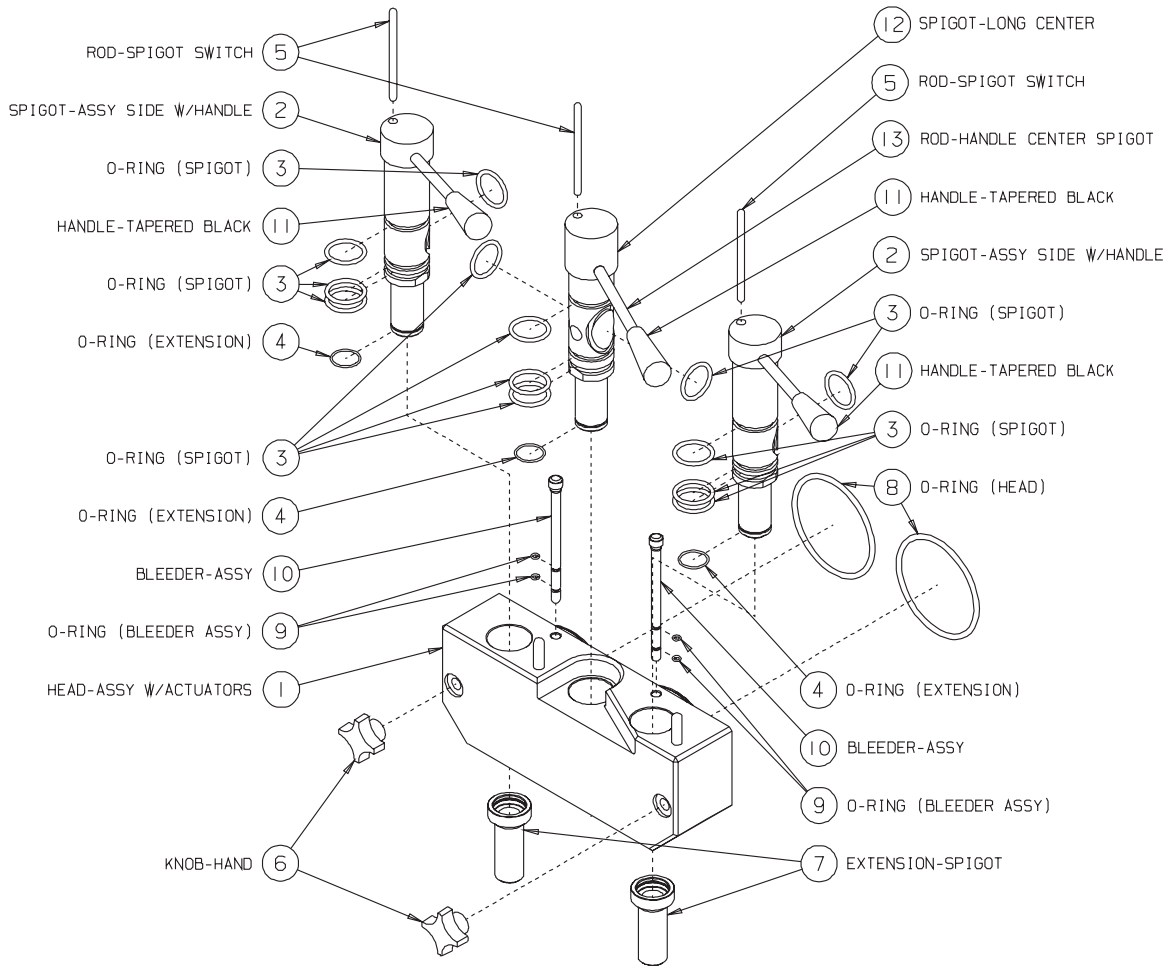

Figure 8-2

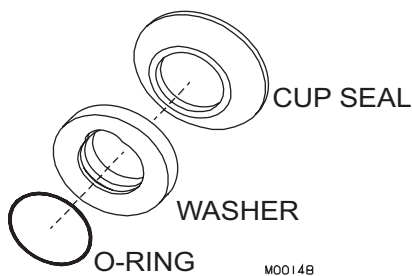

Figure 8-3 Shaft seal

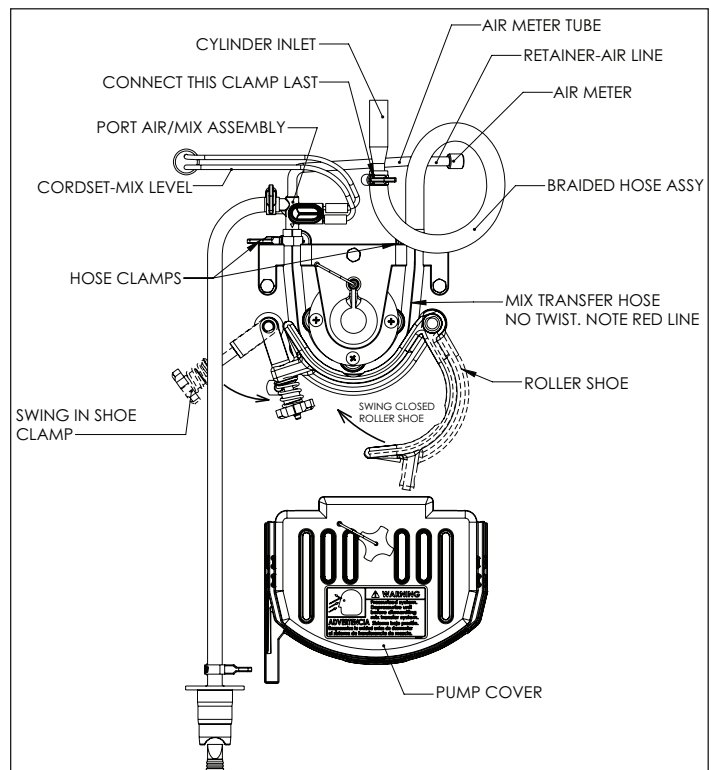

Figure 8-4 MTS

8.2 Disassembly Instructions (continued)

**CAUTION**  
 To avoid electrical shock or contact with moving parts, make sure all controls are in the "OFF" position and that the main power switch is turned "OFF". Some freezers have more than one disconnect switch.

**CAUTION**  
 Make sure freezer is depressurized before proceeding.

**CAUTION**  
 To prevent bacteria growth, remove ALL o-rings when disassembling for cleaning. Failure to do so could create a health hazard.

1. If there is product in the freezer, refer to Sec. 9 Closing Procedures, 9.1 Draining Product.
2. (See figure 8-2.) Remove the spigot rods (5) by lifting up out. Remove the hand knobs (6) and pull the dispensing head (1) straight out.
3. Remove the cylinder bushings and beater shafts from the cylinders.
4. Remove the scraper blades and shaft seals from the beater shafts. Remove the drip tray and drip tray insert.
5. (See figure 8-3.) Remove the cup seals and o-rings from the plastic washers on the shaft seal assemblies.
6. Remove the spigot assemblies, air bleed plugs, and o-rings from the head and spigot assemblies.
7. Remove mix tanks, covers, and low mix probes.

8. Remove the MTS hose assemblies from the Mix Transfer Systems as follows (figure 8-4):
  - a. remove cover,
  - b. loosen the hand knob,
  - c. swing back the shoe clamp,
  - d. swing open the roller shoe,
  - e. loosen the clamp on braided hose,
  - f. remove duckbill in mix adapter, keep adapter in bucket.
  - g. Slide hose assembly out of roller support housing, this will allow water in tube to drain into bucket. pull tube off cylinder inlet and slide hose assembly out of roller support housing.
9. Disassembly MTS hose assemblies as shown in figure 8-5, and take to cleaning sink.

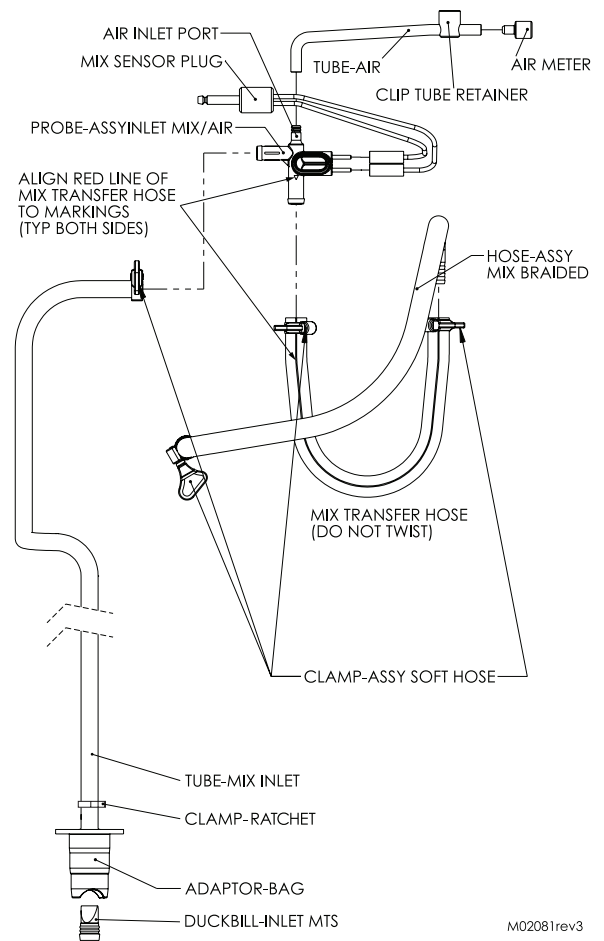

Figure 8-5 MTS Hose Assembly

## 8.3 Cleaning Instructions

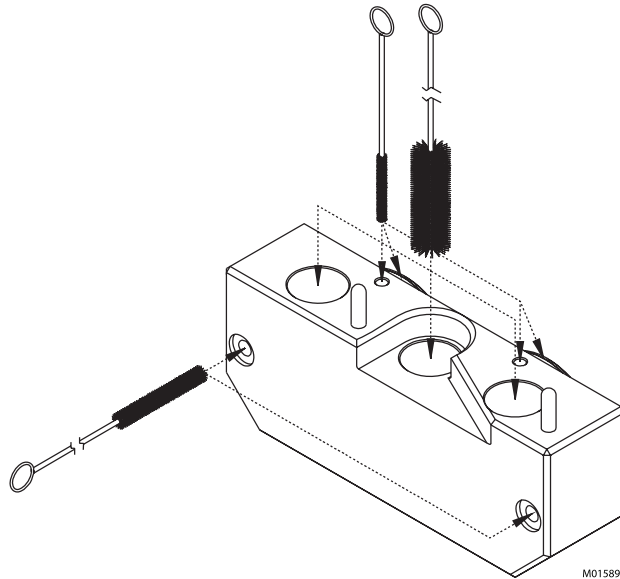
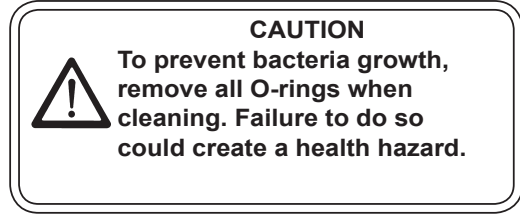
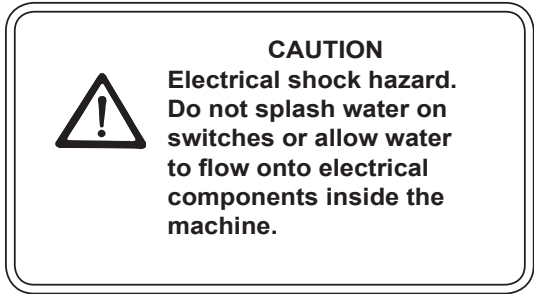

Figure 8-4

**NOTE:** It is your responsibility to be aware of, and conform to, the requirements for meeting federal, state, and local laws concerning the frequency of cleaning and sanitizing the freezer.

1. Prepare a three compartment sink for washing, rinsing, and sanitizing parts removed from the freezer, per applicable health codes. Also prepare a clean surface to air dry all parts.

**Important:**  
*Do not use unapproved sanitizer or laundry bleach. These materials may contain high concentrations of chlorine and will chemically attack freezer components.*

**NOTE:** The sanitizer should be mixed according to the manufacturer's instructions to yield 100 PPM available chlorine solution (example: Stera-Sheen Green Label). Use warm water (100°-110°F or 38°-43°C) to wash, rinse, and sanitize.

2. Wash all the parts removed from the freezer thoroughly with dish detergent soap. Clean the following parts with the appropriate supplied brush:
  - a. the mix tanks, pickup tube assemblies, hoses, and probes
  - b. the head spigot openings, center spigot ports, o-ring grooves, dispense nozzle mounting rings, and mix ports, as shown in figure 8-4
  - c. the spigot o-ring grooves, nozzles, the shaft cup seals, plastic washers and o-rings as shown in figure 8-5

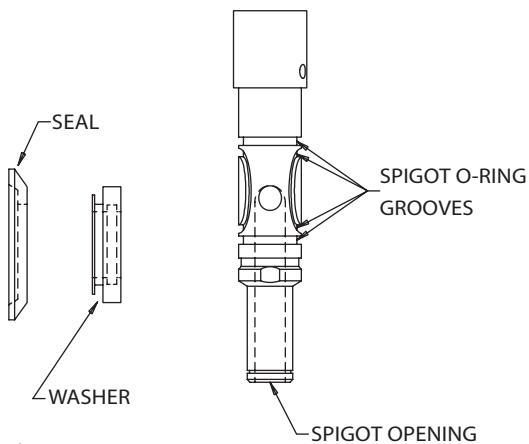

Figure 8-5

—continued

8.3 Cleaning Instructions (continued)

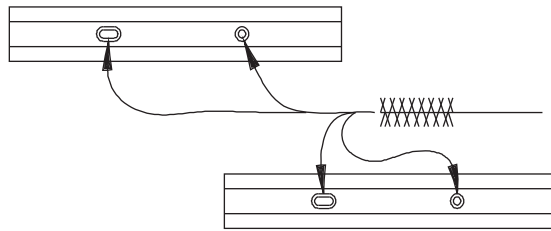

Figure 8-6 Scraper Blade pin holes

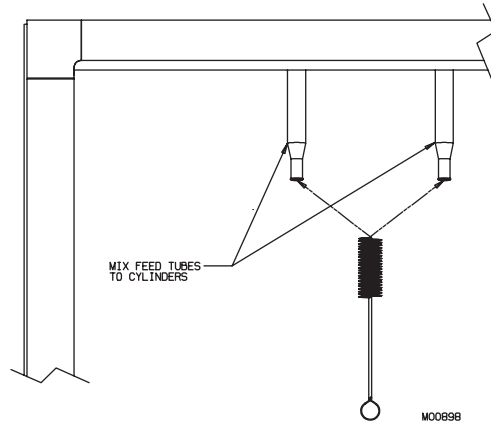

Figure 8-7 Brush inside of cylinder mix feed tubes

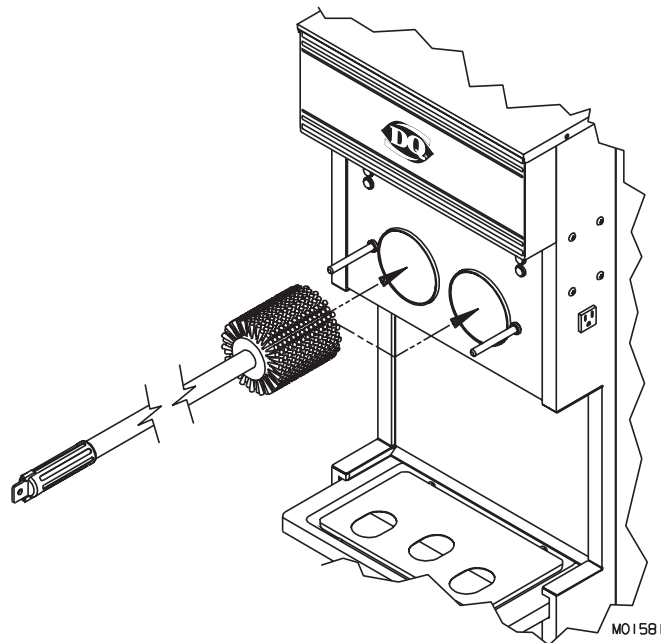

Figure 8-8 Clean Cylinders

- d. the air bleed plug o-ring grooves
- e. the beater shaft and the scraper blade pin holes, as shown in figure 8-6.

**Important:**

**Do not leave parts in sanitizer for longer than 15 minutes.**

3. After all parts are washed, rinse and place them in the sanitizing solution. For proper sanitizing, the parts must remain fully immersed in the sanitizer for 5 minutes. Allow the parts to air-dry after sanitizing.
4. The following must be thoroughly brushed first with a warm dish detergent solution, then rinsed with clear water followed by the sanitizing solution.
  - a. mix feed tubes from the refrigerated cabinet to the cylinders as shown in figure 8-7
  - b. the inside of the cylinders including the back wall as shown in figure 8-8
  - c. the inside of the drain tube as shown in figure 8-9

### 8.3 Cleaning Instructions (continued)

5. Remove the drip tray and insert. Wash in a warm dish detergent solution rinse with clear water and place in sanitizing solution for 5 minutes.
6. Wash the outside of the freezer and inside of the cabinet with a warm dish detergent solution. Rinse with clear water.

**Replace worn brushes.**

**Use only original or authorized replacement parts.**

**See Accessories Parts List in Part II of this manual to order new brushes.**

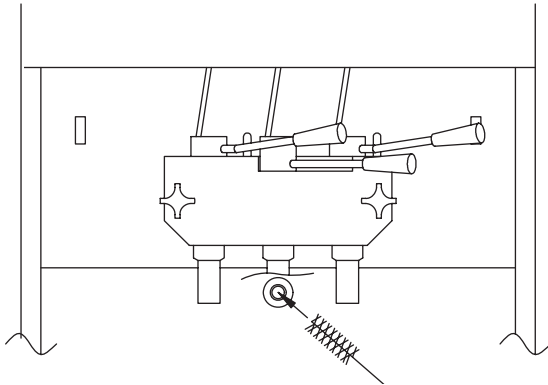

**Figure 8-9 Clean Drain Tube**

### 8.3.1 Cleaning and Lubricating - MTS Assembly

**NOTE:** Clean the shoe weekly or when necessary. **Do not interchange the shoe with any other MTS shoes.**

1. Remove the o-rings and slide the shoe off of the pivot arm and the swing clamp off of the clamp arm. See figure 6-11.
2. Carry to the sink, wash in mild detergent with the brush provided and dry thoroughly.
3. Brush in between rollers. Flush clean with water bottle.

**Important:**

**Do not let shoe sit in sanitizing solution or water. Corrosion will occur in bore.**

4. Lubricate the shoe pivot arm and the swing clamp arm with food grade lubricant such as Petrol-Gel.
5. Reassemble the shoe and o-ring on pivot arm.
6. Reassemble the shoe swing clamp and o-ring on the swing clamp arm.

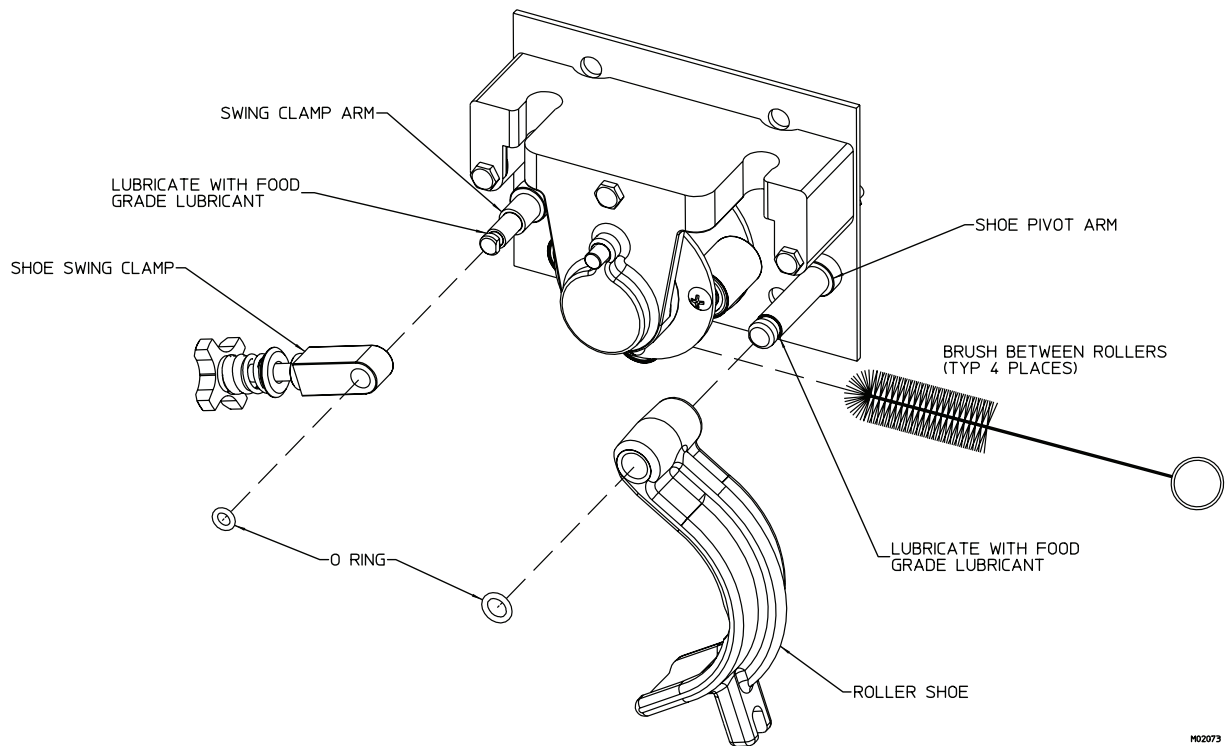

**Figure 8-11**

# 9 Assembly

**CAUTION**

To avoid electrical shock or contact with moving parts, make sure all switches are in the "OFF" position and that the main power supply is disconnected. Some freezers have more than one disconnect switch.



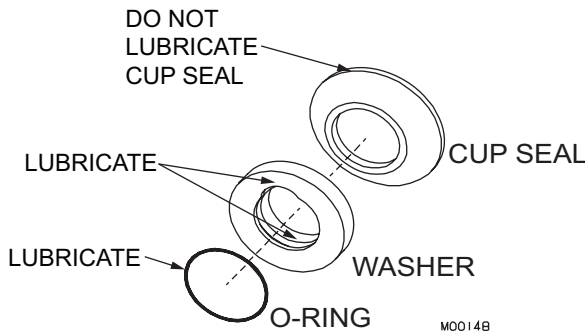

**Three Piece Shaft Seal**

**Figure 9-1 Shaft Seals**

Correct assembly of the freezer is essential to prevent leakage of the product and damage to the freezer. You will need an approved lubricant (such as Lubri-Film Plus). Make sure all parts of the assemblies have been cleaned and sanitized before assembling. Persons assembling the freezer must first wash and sanitize their hands and forearms with an approved sanitizer.

1. Install the cup seal and o-ring on the washer (see figure 9-1). Apply a light amount of approved sanitary lubricant (such as Lubri-Film Plus) to the o-ring and the face of the plastic washer opposite the bell portion of the seal. Do not allow any lubricant to come into contact with the bell shaped rubber portion of the seal.
2. Install the shaft seals over the rear of the beater shafts. If using the three piece shaft seal the bell-shaped portion will be facing the rear of the freezer (see figure 9-2). Remove excess lubricant from the drive end of the beater shaft.
3. Place the scraper blades on the beater shafts, making sure the blades are installed properly. Proper blade installation is with flat side against cylinder wall. (See figure 9-3.)

—continued

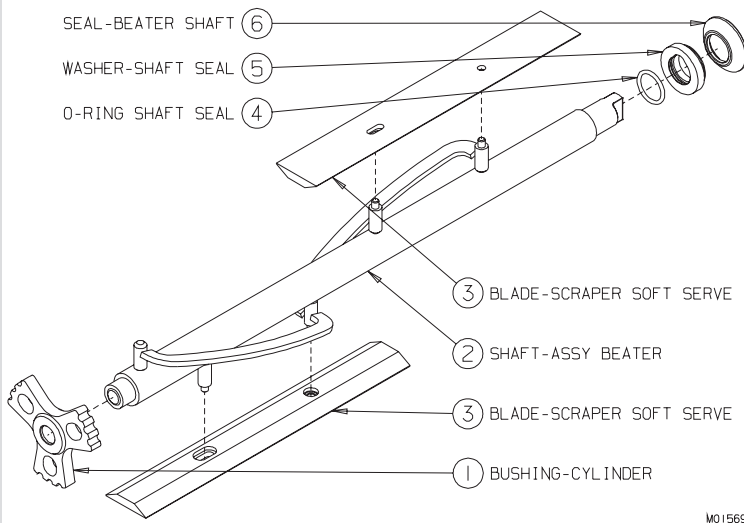

**Figure 9-2 Beater Shaft Assemblies**

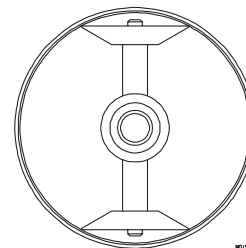

**PROPER BLADE INSTALLATION IS WITH FLAT SIDE AGAINST CYLINDER WALL.**

**Figure 9-3**

## 9 Assembly (continued)

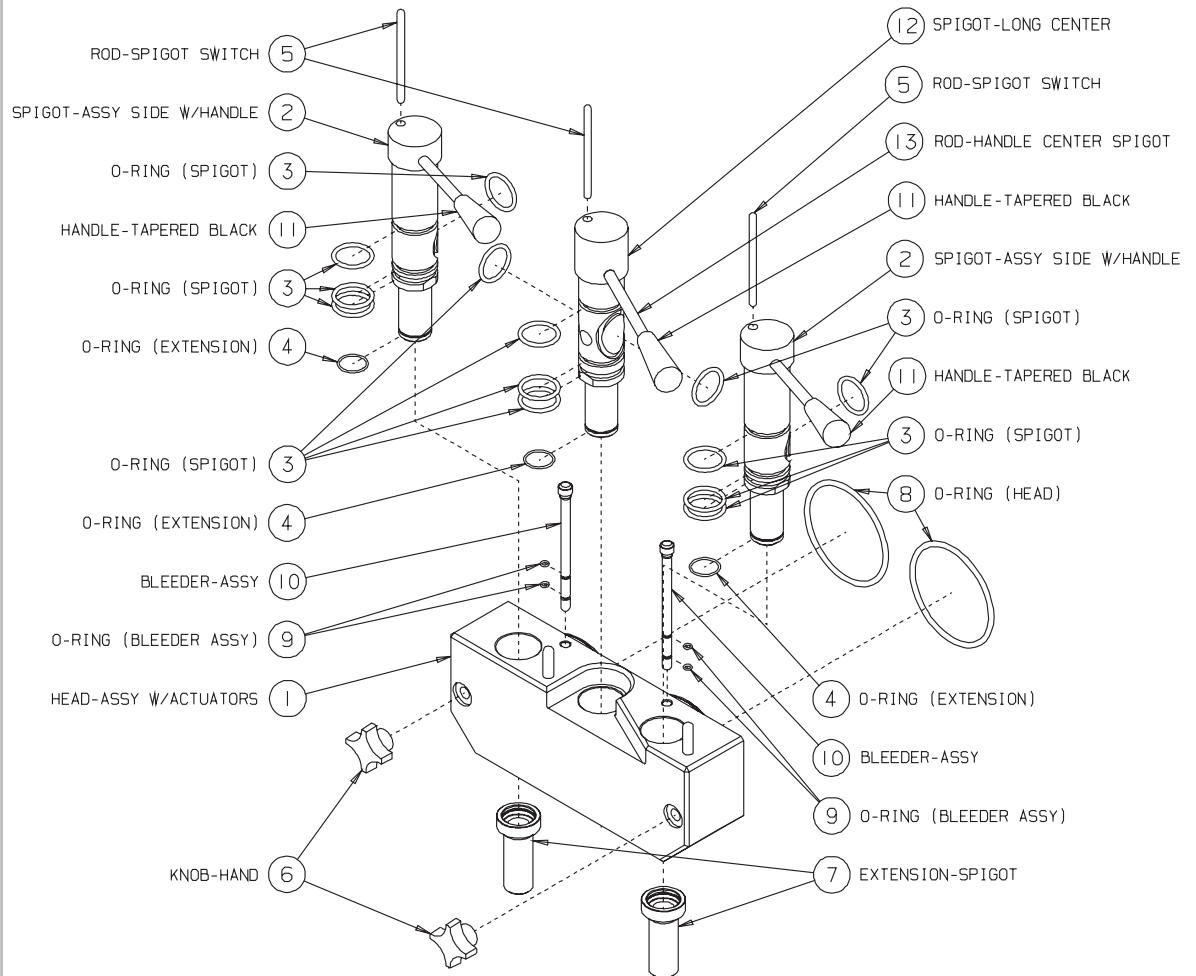

**Figure 9-4 Head Assembly**

M01586

4. Insert the assembled beater shaft into the cylinder by placing the rear blade on the bottom of the cylinder. This will center the beater and allow alignment with the drive coupling. Slide beater shaft into cylinder until shaft engages drive coupling. Repeat for second cylinder assembly.
5. Lubricate the inside surface of the cylinder bushings and place on the end of the beater shaft assemblies. The bushings will slide on only one way.
6. See figure 9-4. Install and lubricate the o-rings (3) (see o-ring chart, last page) on the dispensing spigots (2,12) and insert the spigots into the head (1). Check by turning the spigots side to side, making sure they move freely.
7. Place the extension or holding o-ring (4) onto the spigots. Do not lubricate this o-ring.
8. Install and lubricate the 4" head o-rings(8).

**Important:**  
**Dispensing head must be installed for beater motor(s) to operate. Do not interchange heads from other freezers.**

—continued

## 9 Assembly (continued)

9. Install and lubricate the o-rings (9) on the air bleed plugs (10). Insert the plugs in the head assemblies (1).
10. Install the dispensing head onto the freezer by aligning the studs with the holes in the head and sliding toward the freezer. Finger-tighten the hand knobs evenly.

**Important:**  
Excessive force will damage the head. Do not use tools to tighten.

**Important:**  
Always make sure the head bushing is positioned on the beater shaft properly. Operating the freezer with a missing or badly worn bushing will damage the beater and cylinder.

11. Install the spigot rods (5). For yogurt mixes, install the nozzles on the mix

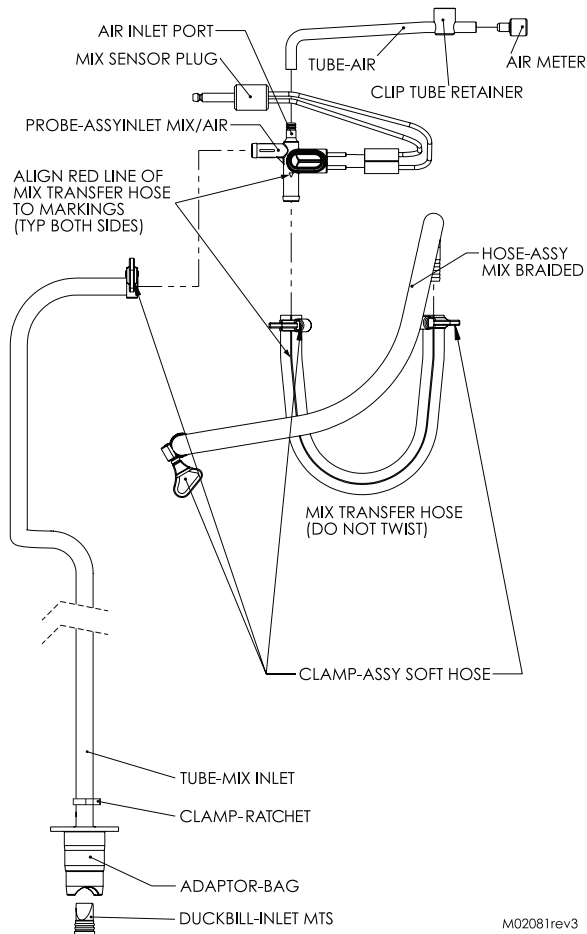

M02081rev3

outlet at the bottom of the spigots before sanitizing.

**Important:**  
Always inspect the transfer hose during assembly for wear. Do not use tools or sharp objects to remove hose.

**Important:**  
Use original H. C. Duke transfer hose only. Your freezer will not operate properly with any other type of hose. Never twist the transfer hose when assembling or installing.

**Important:**  
Replace transfer hose every 30 days.

12. Assemble the MTS hose assembly as shown in figures 9-5 and 9-6. The transfer hose has a red locating line. Hold the mix/air inlet port with the transfer hose mix port on your right and the barbed air port facing away from you. With the locating line up, slide the mix transfer hose onto the port. Then slide a clamp over the hose to secure it to the port. Finger tighten only! The thumbscrew must lie parallel to the mix/air inlet port.
13. Install o-ring on mix inlet tube assembly. Place the tube assembly end into the port assembly and swing retainer clip over to lock tube assembly in place.
14. Install mix tube boot with flat side first, over the tube assembly.
15. Insert the duckbill valve into the bottom of the pickup tube. Push until the two ribs are completely inserted.
16. Refer to figure 9-6. Install the MTS hose assembly by first placing the clamp next to the braided hose, above the roller bearing support on the right side and push hose into slot. Place the transfer hose under the rollers. While holding the pickup tube stretch the hose so the left hand clamp is above the roller bearing support and push the hose into the slot.

Figure 9-5 MTS Hose Assembly

—continued

## 9 Assembly (continued)

**Important:**

**Do not twist the hose assembly while installing.**

17. Check to ensure the transfer hose is straight and centered on the roller assembly by observing the locating line. The line should be in the same position at the inlet and outlet guides of the roller bearing support, as shown in figure 9-6.
18. Swing the shoe over hose and tighten the swing clamp hand knob until it stops.
19. Insert the air tube into the retainer in the back of the cabinet.
20. Insert the MTS cover over stud. Hose clamps should be exposed. Tighten cover knob. Hand tighten only.

21. Loop the braided hose towards you and slide the hose over the cylinder inlet tube. Tighten the clamp. Make sure the braided hose is not twisting transfer hose.

**Important:**

**The MTS will not operate unless the cover is installed and secured by the hand knob.**

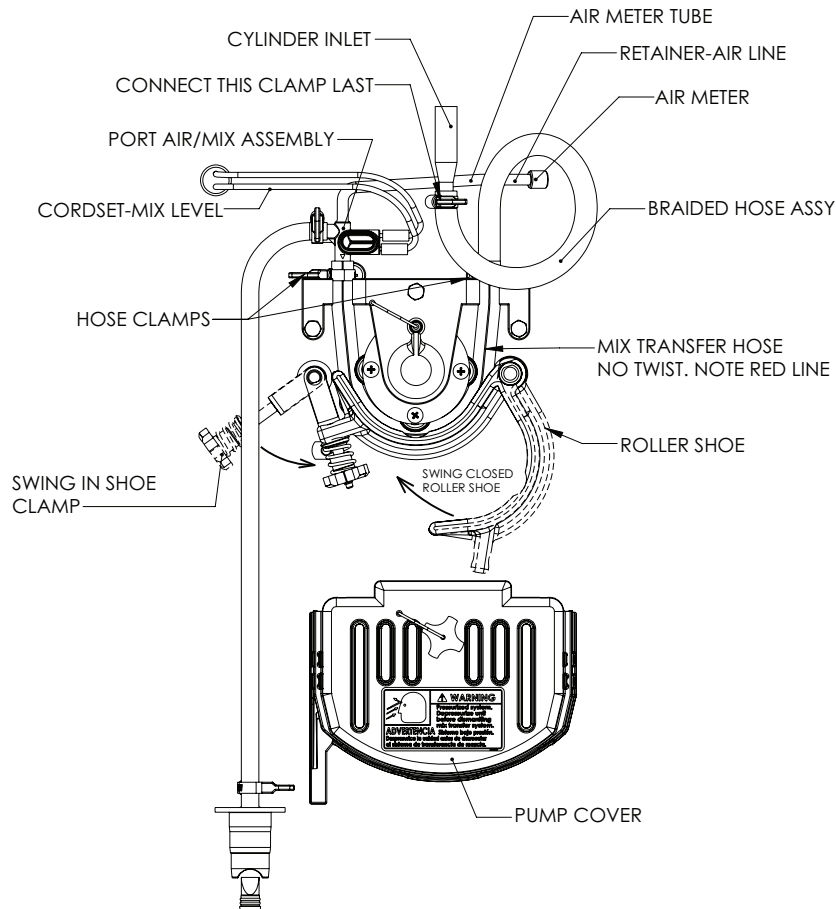

**Figure 9-6 MTS**

# 10 Start-up Instructions

## 10.1 Sanitizing



**CAUTION**  
Mix Transfer System will be pressurized during operation. Make sure all components and fasteners are secure before start-up.

The washing and sanitizing instructions explained in this manual are important procedures to remove bacteria and maintain a clean, sanitary freezer. IDQ requires the soft serve freezer to be disassembled, washed, and sanitized daily according to the instructions in the manual. Always sanitize prior to assembling to ensure the best possible cleanliness.



**CAUTION**  
To prevent bacteria growth, use only approved sanitizers to sanitize the machine. Sanitizing must be done just prior to starting the machine. Failure to do so could create a health hazard.

**IMPORTANT:**  
*Do not use unapproved sanitizers or laundry bleach. These materials may contain high concentrations of chlorine and will chemically attack freezer components.*

**NOTE:** It is your responsibility to be aware of and conform to the requirements for meeting federal, state, and local laws concerning the frequency of cleaning and sanitizing the freezer.

1. Prepare 2 gallons (7.5 liters) of sanitizing solution for each cylinder. Sanitizing solution must be mixed according to manufacturer's instructions to yield 100 PPM strength chlorine solution (example: Stera-Sheen Green Label). Use warm water (100° to 110°F or 37° to 43°C) to wash, rinse, and sanitize.
2. Wash and sanitize your hands and forearms.

3. Clean the interior mix tank walls, the underside of the tank covers and low mix probes with sanitizer liquid and the appropriate brush provided.
4. Place the mix tank in the refrigerated cabinet. Fill with sanitizing solution.

**Important:**  
*Never let the sanitizer remain in the freezer for more than 15 minutes.*

5. Immerse the pickup tubes into the sanitizer solution and sanitize the outside portion. If plastic mix bag systems are used, be sure all adapters and items that will come in contact with mix are sanitized.
6. Place an empty container under the dispensing head.
7. Open the air bleed plugs by pulling up until the plugs touch the bottom of the switch box.
8. Turn on the main power switch to the freezer. The spigots must be closed. Using the control panel press the L2 & R2 keys to turn the MTS pumps "ON". This will push the sanitizer up into the cylinders.
9. When sanitizer flows out the bottom of the head, close the air bleed plugs.

**Important:**  
*DO NOT use the "FREEZE" setting with sanitizer in the cylinder. The freezer will be damaged.*

10. Using the control pad press the L1 & R1 keys to turn the beaters "ON" and allow the beaters to run for 5 minutes. At this time check for leaks around the head, drain tube, clamps, and MTS.
11. Drain the solution from the cylinders by slowly turning the spigot handles open.
12. Leaving the spigots open, press L1 & R1 keys to turn the beaters "OFF" and let the MTS force all possible sanitizer out of the freezing cylinders.

—continued

## 10.1 Sanitizing (continued)

**NOTE:** Some sanitizer will remain in hoses and cylinder.

13. Press L2 & R2 keys to turn the MTS pumps "OFF".

14. Remove the pickup tubes, holding the top 6" portion only.

15. Remove the mix tanks and empty any remaining sanitizer.

## 10.2 Priming

Priming the freezer removes all excess air and sanitizer from the freezing cylinder and sets the proper overrun for the first cylinder of product.

1. Wash and sanitize your hands and forearms.
2. Holding the top 6-inch (15cm) portion only, insert each pickup tubes into the sanitized mix tank through the small hole in the rear cover and set tanks in the cabinet.
3. Slide each boot seal down on the mix tank cover.
4. Fill the mix tanks with mix and install the front covers.

5. Insert each sanitized mix probes through the large hole in the rear cover, and connect the probe cords to the probes and to the back of the cabinet.

6. Close the cabinet door.

7. Place an empty container under the dispense head on the drip tray.

8. Pull up the air bleed plugs

9. Open the side spigots.

10. Press L2 & R2 keys to turn the MTS pumps "ON" allowing the mix to push the remaining sanitizer from the freezer.

11. Close the spigots one at a time when pure mix is coming out.

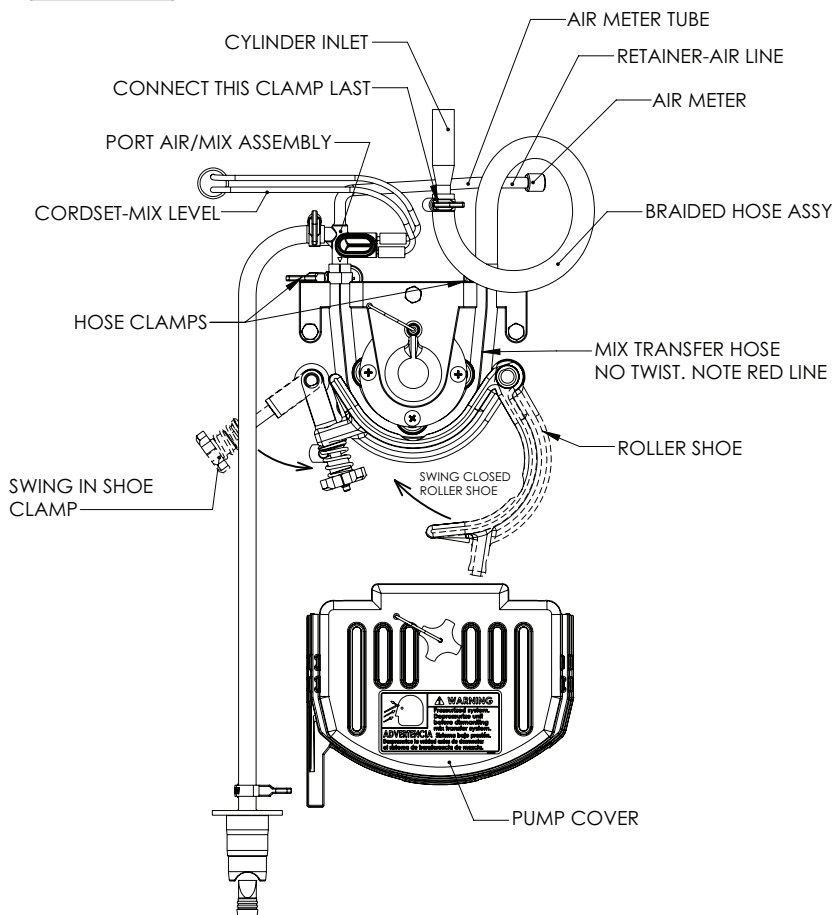

Figure 10-1

**Important:**

**Failure to completely remove sanitizer or water from the freezing cylinder before placing in "FREEZE" will cause the scraper blades to break and damage the freezer.**

12. Allow the MTS to fill the cylinder until mix flows from the bottom of the air bleed plug openings in the bottom of the dispense head, close the air bleed plugs. Wait for the MTS to fill the cylinders and shut off.

13. After the cylinders are pressurized and the MTS has cycled off (approximately 30 seconds) Press the left and right "Freeze" keys.

14. Allow the freezer to cycle for 15-20 minutes. The product is now ready to serve.

## 10.3 Dispensing Product

1. To dispense product, grasp the spigot handle, hold the container which is to be filled with product below the spigot, and slowly open the spigot until product is dispensed at a comfortable rate.
2. When the proper portion has been dispensed, close the spigot.
3. The freezer will continue to run a short time (approximately 12 seconds) following the dispensing of the product. If a large portion has just been dispensed, a longer period of time may be required for the freezer to shut off.
4. If the freezer has not been used for more than two and a half minutes, and the product requires a firm base, then dispense a small amount of mix in the spigot into a separate container.

**NOTE:** For shakes, large sundaes, floats and other similar products, this practice of drawing off a small amount into a separate container is not necessary and should be discouraged.

5. Observe the level of mix throughout the day to avoid running out of product in the mix containers or bags.
6. Periodically check the temperature and overrun of product and make sure it is within the specified limits.

**IMPORTANT:**

***If proper mix level is not maintained, a freeze-up may occur and cause damage to the freezer.***

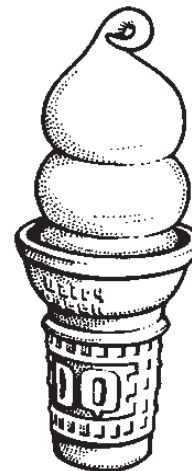
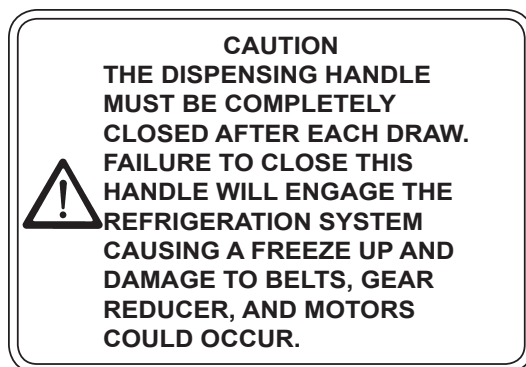

# 11 Closing Procedures

## 11.1 Draining Product

At the end of each day of operation, the freezer must be rinsed, sanitized, and disassembled. The parts also must be washed, rinsed, sanitized, and prepared for reassembly.

To remove frozen product from the cylinders:

1. Press the L1 & R1 keys to enter "CLEAN" mode.
2. In "CLEAN" mode press L1 & R1 to turn the beaters on and let the beaters run for 5 minutes. This will allow the product in the cylinders to soften.
3. In the cabinet below (see figure 11-1). Disconnect the mix probe cords from the back of the cabinet.
4. Remove each mix tanks while pulling the stainless steel pickup tube from the mix tank. Place the pickup tubes in a clean sanitized container.
5. Mix must be handled according to local health codes.
6. Place a clean sanitized container under the dispensing head.
7. Very slowly open the side spigots and dispense the semi-frozen product until it quits dispensing. To eliminate waste, dispense as much as possible for use in pints, quarts, and/or novelties.
8. Close spigots. Press L2 & R2 to turn the MTS pumps "OFF".
9. Place the mix pickup tubes into a container and fill with cold water. Turn the MTS pumps "ON" and allow the MTS to fill and pressurize the cylinders.
10. Very slowly open the spigots and dispense the cold water. Follow with a container of warm water and repeat until the dispensed water is clear. Drain remaining water from the cylinders.
11. Turn the beaters and MTS pumps "OFF". Close the spigots
12. Prepare 2 gallons (7.5 liters) of sanitizing solution for each cylinder. Sanitizing solution must be mixed according to manufacturer's instructions to yield 100PPM available chlorine solution (example: Stera-Sheen Green Label). Use warm water (100° to 110°F or 37° to 43°C).
13. Insert the mix pickup tubes into the sanitizing solution.
14. Place an empty container under the dispense heads.
15. Pull the air bleed plugs up until they touch the bottom of the switch box. Open the spigots.

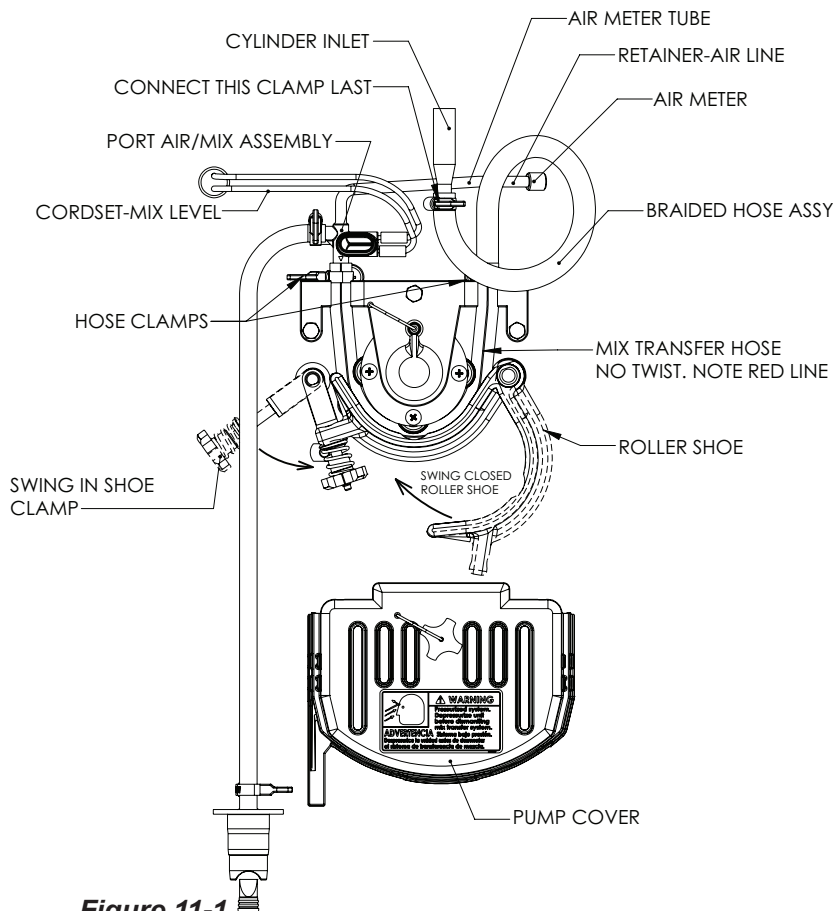
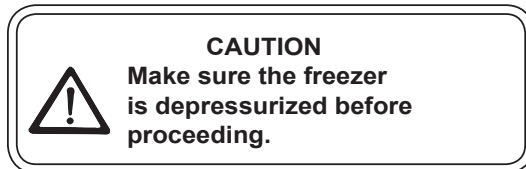

Figure 11-1

— continued

## 11.1 Draining Product (continued)

- Turn the MTS pumps "ON". When sanitizer flows out the bottom of the head, close the air bleed plugs and allow the MTS to pressurize the cylinders.
- Press L1 & R1 to turn the beaters "ON" and allow them to agitate for 5 minutes.



**IMPORTANT:**  
**Do NOT use the "FREEZE" position with sanitizer or water in the cylinder. The freezer will be damaged.**

- Slowly open the spigots and allow the MTS to push the sanitizer out of the cylinders. Leaving the spigots open, turn the beaters "OFF". Leave the MTS pumps "ON" and allow the pumps to force all remaining sanitizer from the cylinders. When sanitizer quits flowing, place the MTS pump switches to "OFF"
- Remove the pickup tubes from the sanitizing solution.
- Refer to Disassembly and Cleaning Instructions.

## 11.2 Night Switch Operation

- In areas where health codes will allow, the freezer may be switched to night mode operation. This will allow the freezer to cycle all night and maintain approximately 36°F (2.2°C) product in the cylinders and cabinet.
- To switch the freezer to Night mode, press the Soft key located below the image of the Moon on the display. (Pictured Below)
- Remove any spigot extensions and spigot extension o-rings that might be installed, remove the drip tray assembly and clean all soiled surfaces with soap and water. Fill

the wash bottle (HC196103) with approved sanitizing solution, using the wash bottle and a brush clean the spigots and openings.

- Repeat step 3 prior to putting the machine back into day mode for the days use.

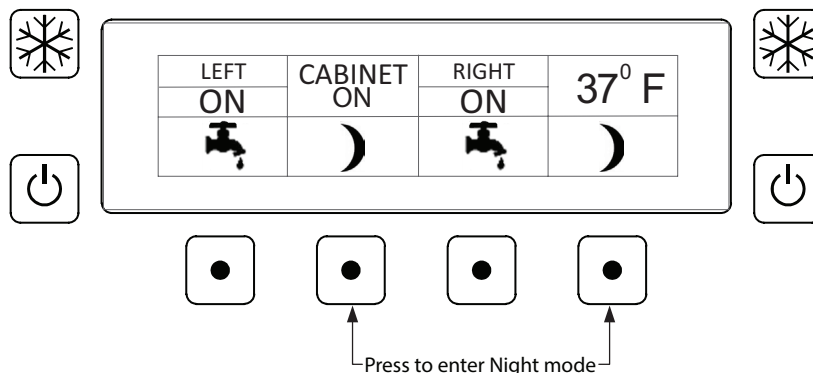
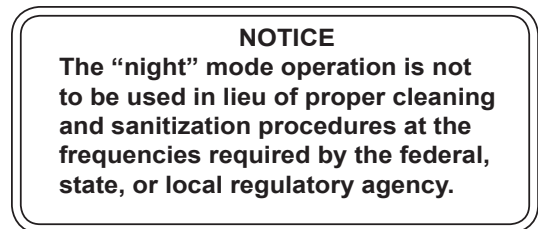

Figure 11-2

## 12 General Information

### 12.1 Dairy Queen® Mix

1. Standard approved Dairy Queen® mix weight is approximately 9.25 lbs. per gallon (1.1 kilograms per liter).
2. The mix, when delivered, should be:
  - a. at a temperature of no more than 40°F (4°C).
  - b. displaying no separation such as clear or semi-clear liquid layer on top.
  - c. nearly free of foam in a freshly opened container.
3. Mix should be used within seven days from the date of delivery and should not be over seven days old when delivered.
4. Store mix at a temperature of 35° to 38°F (2° to 3°C).
5. Check both the taste and smell of the mix, and thoroughly stir or agitate the mix prior to use. Be sure any stirring device is properly sanitized before coming in contact with the mix.
6. The mix container must be identified by a tag or label which states that it is Dairy Queen® mix and a code identifying its age.
7. The mix used to produce Dairy Queen® product must be furnished by an approved mix supplier.

Report any mix problems to the mix supplier. If the problem persists, contact IDQ Food Products Department.

**IMPORTANT:**

**This machine is not intended to process mixes containing abrasive materials. Sold particles that do not dissolve in water may cause premature wear on components and void the manufacturer's warranty.**

### 12.2 Checking the Frozen DQ® Product

Two measurements of product consistency are **temperature** and **overrun**. Several observations can be made by looking at and tasting the product, but actual measurement of temperature and overrun provides precise information concerning the condition of the product being served and the operation of the freezer and the mix transfer system.

Standard Dairy Queen® product should be between 17° and 19°F (-8° and -7°C). It should have an overrun of 40 to 45%. Its appearance should be “dry” and appear

much like silk. If the product appears “wet” or “slick” then it is usually an indication that the temperature is too high. If the product appears pockmarked and soft, it may be an indication of too much overrun. If the product appears grainy and hard, it is an indication of either too low overrun or too low temperature. In any of the above cases, always measure temperature and overrun to see if they fall into normal operating ranges.

### 12.3 Product Temperature

The product temperature should be measured by a calibrated thermometer. If you suspect that the thermometer is out of calibration, test it by filling a cup with ice and water and inserting the thermometer into it. After a few minutes, the thermometer should read exactly 32°F (0°C). The freezer should maintain a product temperature variation of only 1½°F (1°C) on a product temperature

of 18°F (-8°C). The control panel dial thermometer should read 5° to 15°F (-15° to -9°C) when product is being dispensed at 18°F (-8°C). Although this dial thermometer is not accurate for measuring product temperature, it is wise to accustom the operators to observe the dial thermometer for its normal operating reading.

### 12.4 Overrun

As mix is being frozen in the freezing cylinder, air is incorporated into the mix to increase its volume as well as the taste and appeal of the finished product. The increase in volume is called **overrun**. Forty five percent overrun means a volume increase of 45%—10 gallons of liquid mix has become 14.5 gallons of finished product.

Controlled overrun is important in maintaining consistency in product quality. Too much overrun (air) results in a light, fluffy product lacking the cold, refreshing appeal of a quality product. Too little overrun results in a grainy, heavy product.

To correctly measure the overrun, take a pint container and adjust your scale to zero with the container on the scale. Fill the container with liquid product even with the top of the container and record the weight. Then fill the container with frozen product, leaving no voids or air spaces in the container. Strike off the excess product so it is even with the top of the container and weigh it. Use the following formula to figure overrun percentage:

Weight of liquid mix minus weight of frozen product. Divide the difference by the frozen weight.

**Example:**

<b>Weight of one pint of mix</b>	<b>=</b>	<b>18 oz.</b>
<b>Weight of one pint frozen product</b>	<b>=</b>	<b><u>12 oz.</u></b>
<b>Difference</b>		<b>6 oz.</b>

**6.0 oz. divided by 12 oz. = .5**  
**.5 x 100 = 50% overrun**

H. C. Duke and Son, LLC can provide a scale (part #HC158049) that is graduated in overrun percentage.

Section 10.7 is an overrun chart which shows the net weight of one measure pint of frozen Dairy Queen® product in grams, ounces, and their corresponding percentage of overrun.

## 12.5 Overrun Adjustment

The overrun is regulated by the air meter. You were supplied with six air meters, each containing a different size orifice. The smaller the hole and number, the lower the overrun. The larger the hole and number, the higher the overrun. Each half-step change of the air meter number will result in a 3-5% change in overrun. Each full-step change will result in a 8-10% change in overrun.

The orifice or hole in this air meter must be open at all times. It is the only source of air into the freezing cylinder. Check this daily!

The mix will be a determining factor as to the amount of overrun you will be able to achieve. Some mixes will accept more air than others, thus affecting the size of air meter you can use.

Test to see which air meter will give you the best overrun and the best product. Run each air meter for a few hours until you make the determination. (You may have a slightly higher overrun when you first start up the freezer.) After the freezer has run long enough to dispense at least one full cylinder of product, you will have the overrun that the freezer will hold the remainder of the day.

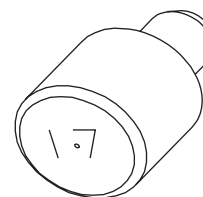

**Figure 12-1 Air Meter**

## 12.6 Rerun

**Rerun** is product that has been drawn through the freezer into a container and has melted down to be reprocessed.

1. International Dairy Queen® does not permit the use of rerun.
2. Rerun product is unable to accept the same amount of air as fresh product; therefore, you cannot produce a quality product with rerun mix. Product may appear grainy and icy, and operational problems may result from the use of rerun.

For further information contact the Service Department of H. C. Duke & Son, LLC by phone at (309) 755-4553 or (800) 755-4545.

12.7 Overrun Chart

Net. Wt. 1 Pint of Frozen Dairy Queen In Ounces	Net. Wt. 1 Pint of Frozen Dairy Queen In Grams	Percentage of Overrun
13.7	388.4	35
13.6	385.5	36
13.5	382.7	37
13.4	379.9	38
13.3	377	39
13.2	374.2	40
13.1	371.4	41
13.0	368.5	42
12.9	365.7	43
12.8	362.9	44
12.7	360	45
12.6	357.2	46
12.5	354.3	47
12.4	351.5	48
12.3	348.6	49
12.2	354.8	50
12.1	342.9	51
12	340.1	52
11.9	337.2	53
11.8	334.4	54
11.7	331.5	55

Acceptable  
Range  
for  
Overrun

## 13 Routine Maintenance

H.C. Duke and Son, Inc. recommends the following schedule to help maintain your Model GEN-103 Twin Twist Soft Serve Freezer in like-new operating condition. Take the time to learn and perform these routine procedures and receive in return many years of valuable service from your freezer. Protect your investment!

### DAILY

1. Disassemble, wash, rinse, sanitize, and air-dry all parts that come into contact with the mix or product.



**CAUTION**  
To prevent bacteria growth, remove all o-rings when cleaning. Failure to do so could create a health hazard.

2. Clean the cylinder, cylinder inlet tubes and drain tube with the appropriate brushes.
3. When cleaning, inspect all o-rings, seals and hoses. Replace any o-ring, seal or hose that is worn, torn, or loose fitting.
4. Wipe all exterior surfaces of the freezer to remove any splattered mix.
5. Check overrun and temperature of the product.

### AS NEEDED

#### CAUTION

To avoid electrical shock or contact with moving parts, make sure all switches are in the "OFF" position and that the main power supply is disconnected. Some freezers have more than one disconnect switch.



1. Clean the Mix Transfer System:

#### ***Important:***

***If the transfer hose is assembled improperly or replacement has been neglected, it may be necessary to clean mix from the MTS due to hose failure.***

***If this happens frequently the MTS should be removed for complete cleaning.***

— continued

## 13 Routine Maintenance ( continued)

### AS NEEDED (continued)



**CAUTION**  
Make sure the freezer  
is depressurized before  
proceeding.

- Remove cover, loosen swing clamp and open shoe to gain access to the hose cavity.
- Remove mix transfer hose assembly.
- Lay a towel on the cabinet base below the MTS.
- Using the spray bottle supplied, flush the hose cavity and roller assembly.
- Use a brush (supplied) to clean in between rollers. Flush with sanitizer.
- Wipe all surfaces with a clean dry cloth.
- Remove and clean roller shoe and shoe swing clamp. See figure 13-1.

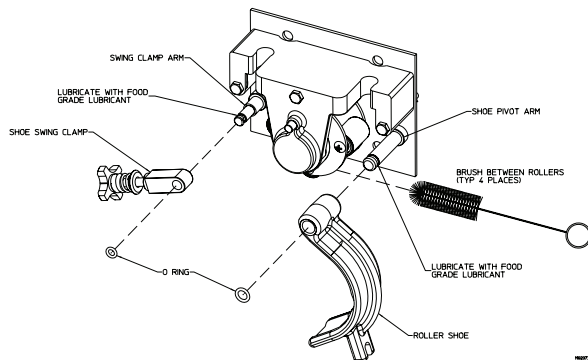
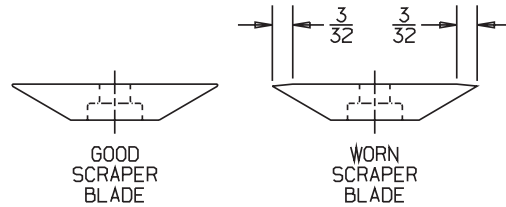

Figure 13-1

### WEEKLY

- Carefully inspect all parts for wear, including seals, O-rings, mix transfer tubes, and blades.
- Replace as required.



**Replace blades if worn 3/16" or more.**

- Check the shaft tang and drive coupling for wear.

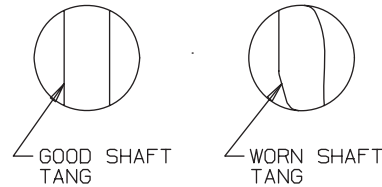

- A worn coupling will have a nonparallel shape on the drive opening.

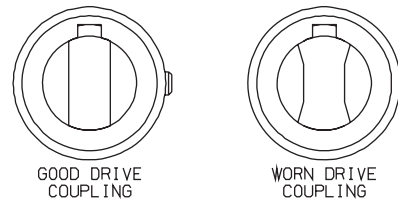

## 13 Routine Maintenance (continued)

### MONTHLY

#### A. Testing the Head Switch

The head switch feature is designed to prevent the beater shaft from being accidentally activated. The beater motors should not operate with the head assembly removed. It is essential that the proper operation of this switch be verified routinely. Use the following instructions to test for proper operation:





**CAUTION**  
To avoid electrical shock or contact with moving parts, make sure the control pad is "OFF" and that the power switch is "OFF".

1. Remove the dispense head and beater shaft assemblies.
2. Place the power switch "ON".



**CAUTION**  
Moving parts. Do not place hands in the freezing cylinder. Severe personal injury could result.

**NOTE:**  
Do this test for each freezing cylinder.

3. Press the  and "BEATER ON". Look inside the cylinder at the rear drive coupling for rotation. Press the  freeze button and look inside the cylinder at the rear drive coupling for rotation. Turn the "BEATER OFF".

#### Proper Operation

When "BEATER ON" is activated or the  freeze button is pushed, the display should read "HEAD SWITCH" and not allow coupling/beater shaft rotation. The head switch is operating properly. When the head is replaced the system should reset and allow beater rotation. Make sure the control pad is "OFF" and that the power switch is "OFF". The freezer is ready to be assembled and put in service.

#### Mechanical Hazard

When "BEATER ON" is activated or the  freeze button is pushed and the rear drive coupling is rotating and the display does not read "HEAD SWITCH". Freezer has a head switch or software problem. Turn the power switch "OFF". **DO NOT** place the freezer in service until the problem has been corrected.

#### B. Water Condenser

Check the outlet water temperature of water-cooled condensers at the floor drain. Ideal water temperatures should be about 95°F (35°C) with a 70°F (21.1°C) water inlet temperature.

— continued

## 13 Routine Maintenance (continued)

### MONTHLY (continued)

#### C. MTS Cover Switch

The MTS cover switch feature is designed to prevent the MTS gear motor from being accidentally activated. It is essential that the proper operation of this switch be verified on a routine basis. Use the following instructions to test for proper operation:

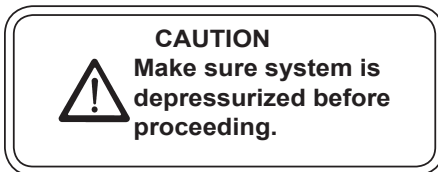

NOTE: Freezer should be cleaned and disassembled for this test.

1. Be sure all switches are in the "OFF" position.
2. Remove the MTS cover to expose the roller assembly.

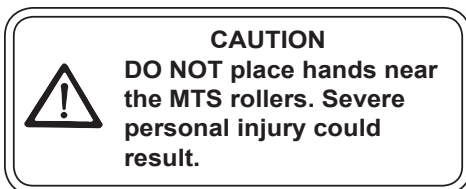

3. Turn MTS switch to "ON".
4. Look at the MTS rollers; they should **NOT** be rotating. If they are rotating, turn "OFF" mix switch and discontinue use until repairs can be made.

5. If there is no movement, slowly install cover and listen for the gear motor to turn on. The cover should be almost completely closed when the gear motor turns on. **DO NOT** insert fingers or objects into roller cavity during this test. If the MTS does not operate as described here, or you are unable to determine if the MTS is operating properly, turn the switches to the "OFF" position, disconnect the main power supply and contact your service technician or the factory. **DO NOT** place the freezer in service until the problem has been corrected.

#### D. Replace the Mix Transfer Hose

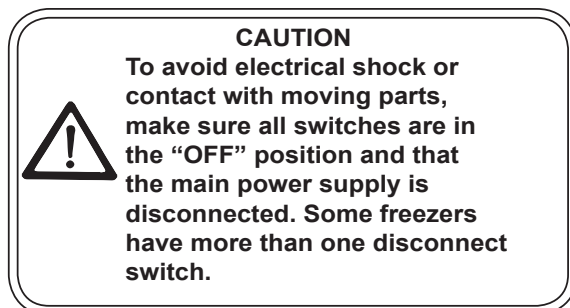
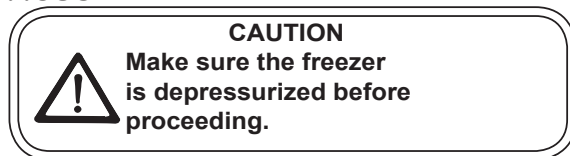

## 13 Routine Maintenance (continued)

### QUARTERLY

#### A. Air Condenser.

**Important:**

**Never use a screwdriver or sharp object to clean between fins.**

Both air and water cooled freezers have an air condenser. The condenser fins

need to be cleaned by your H.C. Duke & Son, LLC. Distributor to remove dirt, lint and dust.

#### B. Refrigeration System

Have your H.C. Duke & Son, LLC. Distributor check the refrigeration system and make any necessary adjustments.

### **WARNING!**

**Failure to properly maintain/clean your air condenser can cause premature compressor failure. Compressor failure due to improper condenser care will void the compressor warranty.**

### 1500 HOURS OF OPERATION OR 6 MONTHS

1. Contact your service technician for the initial oil change of the gear reducer.

### SEMI-ANNUALLY

1. Have the condenser fan motor checked by your service technician. Add oil as needed.

### 5000 HOURS OF OPERATION OR 1 YEAR

1. Contact your service technician to have the oil in the gear reducer changed.

NOTE: Under normal conditions the oil should be changed after 5000 hours of operation or every year, whichever occurs first.

### ANNUALLY

#### CAUTION

To avoid electrical shock or contact with moving parts, make sure all switches are in the "OFF" position and that the main power source is disconnected. Some freezers have more than one disconnect switch.



1. Call your service technician for service to replace drive belts and lubricate fan motor as needed.
2. Call your service technician to clean the inside of the freezer including base, side panels, condenser, etc.
3. Call your service technician to check water-cooled condensers and flush clean to remove scale and deposits if necessary.

## 13 Routine Maintenance (continued)

### Winter Storage

To protect the unit during seasonal shutdown, it is important to store the GEN-103 Twin Twist Soft Serve Freezer properly. Please use the following procedures:

1. Disconnect all power to the freezer.
2. Disassemble and wash all parts that come into contact with the mix with a warm, mild detergent solution. Rinse in clear water and dry all parts thoroughly.
3. Store the loose parts, such as the head assembly, beater assembly, and pump parts in a safe dry place.
4. Do not lay heavy objects on the plastic or rubber parts.
5. Cover the freezer and all loose parts to protect them from dust or other elements that could contaminate them while in storage. Place the freezer in a dry location.
6. On air-cooled freezers, have condenser fins cleaned by authorized service technician.
7. On water-cooled freezers, disconnect the water supply. Use compressed air to blow out all remaining water in the condenser.

***Important***



***The water valve must be opened in order to blow out the condenser. Failure to purge the freezer of water can result in severe damage to the cooling system. Call your local service technician for service or the H. C. Duke & Son, LLC Service Department.***

**USE ONLY ORIGINAL OR AUTHORIZED REPLACEMENT PARTS WITH THIS FREEZER.**

(See your Illustrated Replacement Parts Manual)

Should you have any questions on items that are not included in this maintenance schedule, or problems where service assistance is needed, please call your local authorized service company or H. C. Duke & Son, LLC Service Department, for factory service at **(800) 755-4545 or (309) 755-4553.**

## 14 Troubleshooting Tables

PROBLEM	PROBABLE CAUSE	REMEDY
<b>Unit does not operate.</b> 	1. Freezer unplugged.	1. Plug in freezer.
	2. Fuse or breaker blown at main disconnect.	2. Make sure your freezer is connected to a separate circuit independent from any other electrical equipment. Have technician check fuse or breaker size and check for low voltage; if not within 10% of nameplate rating call power company.
	3. Beater motor out on overload.	3. Press overload reset button. Check product temperature. (Note: cabinet will continue to cool.)
	4. Control circuit overload open.	4. Press overload reset button. If freezer still does not operate contact your Your local service company.
	5. Off on high pressure cut-out or low pressure cut-out control.	5. Contact your Your local service company.
	6. Component failure.	6. Contact your Your local service company.
	7. Faulty selector switch.	7. Contact your Your local service company.
	8. Disconnected or broken wire in electrical circuit.	8. Contact your Your local service company.
<b>Mix or water leaking from drain tube to drip tray.</b> 	1. Damaged beater shaft seal or installed improperly.	1. Replace cup seal or o-ring inside bushing. Install properly.
	2. Beater shaft pitted or damaged where o-ring rides.	2. Replace beater shaft.
	3. Beater shaft end play not set properly.	3. Contact your Your local service company.
<b>Mix leaking at dispensing head.</b> 	1. Faulty head o-ring.	1. Replace o-ring.
	2. Head not properly installed.	2. Install head properly. Replace o-ring if pinched.
<b>Dispensed product too soft. (Product temperature above 19°F)</b>	1. Dirty or blocked condenser, restricted air flow.	1. Unblock condenser or have cleaned by your H.C. Duke & Son, LLC. Distributor.
	2. Component failure.	2. Contact your Your local service company.
	3. Leak in refrigeration system resulting in little or no refrigeration.	3. Contact your Your local service company.

# 14 Troubleshooting Tables (continued)

PROBLEM	PROBABLE CAUSE	REMEDY
<b>Product dispenses slowly out of dispensing head.</b>  	1. MTS pressure too low.	1. See MTS Troubleshooting Charts.
	2. Product too cold.	2. Check product temperature. Should be 18°F (-7.8°C). See Dispensed Product Too Hard.
	3. Low overrun.	3. Check air meter. If plugged, clean. See No Air (Overrun).
	4. Wrong rotation on beater.	4. Have an electrician correct rotation to clockwise as viewed from the front of the freezer.
<b>Dispensed product too hard.</b>	1. Low overrun.	1. Check overrun, if low see MTS Troubleshooting Chart.
	2. Cylinder thermostat erratic or set too cold.	2. Contact your Your local service company.
	3. Spigot switch electrically or mechanically stuck closed. (Unit runs all the time.)	3. Contact your Your local service company.
	4. Component failure.	4. Contact your Your local service company.
	5. Low suction pressure, refrigeration system.	5. Contact your Your local service company.
<b>Freezer runs continually and product continues to get colder.</b>	1. Spigot switch rod engaged.	1. Close spigot completely.
	2. Spigot not seated in head.	2. Push spigot down.
	3. Spigot switch out of adjustment or defective.	3. Contact your Your local service company.
	4. Faulty thermostat or bulb not deep enough in well.	4. Contact your Your local service company.
	5. Starter or relay contact points stuck.	5. Contact your Your local service company.
	6. Faulty time delay.	6. Contact your Your local service company.
	7. Suction pressure too low.	7. Contact your Your local service company.







## 14 Troubleshooting Tables (continued)

PROBLEM	PROBABLE CAUSE	REMEDY
<b>Poor or slow product recovery.</b>	1. Dirty or blocked condenser, restricted air flow – high ambient temperature.	1. Have condenser cleaned by your local service company; lower ambient temperature.
	2. Thermostat cut-in point out of adjustment or malfunctioning.	2. Contact your Your local service company.
	3. Defective condenser fan motor (air cooled)	3. Contact your Your local service company.
	4. Component or compressor failure.	4. Contact your Your local service company.
<b>Compressor does not operate or operates improperly.</b>	1. Trouble in compressor condensing circuit	1. Contact your Your local service company.
	2. Faulty start capacitor, run capacitor or relay. (Single phase only)	2. Contact your Your local service company.
	3. Faulty contactor	3. Contact your Your local service company.
	4. Disconnected or broken wire in switch or capacitor relay box.	4. Contact your Your local service company.
<b>Beater motor does not operate.</b> 	1. Head assembly is not installed.	1. Install head assembly.
	2. Magnetic head switch defective.	2. Contact your Your local service company.
	3. Component failure.	3. Contact your Your local service company.
<b>Compressor and beater motor operates only when dispensing.</b>	1. Cylinder thermostat setting too warm or thermostat defective.	1. Contact your Your local service company.



# 14 Troubleshooting Tables (continued)

PROBLEM	PROBABLE CAUSE	REMEDY
<b>Compressor and beater motor do not operate when dispensing.</b>	1. Spigot switch(es) defective or out of adjustment.	1. Contact your Your local service company.
	2. Component failure.	2. Contact your Your local service company.
<b>Cabinet too cold. (below 35°F [1.7°C])</b>	1. Cabinet setting too low.	1. Contact your Your local service company.
	2. Defective thermostat.	2. Contact your Your local service company.
	3. Cabinet solenoid stuck open	3. Contact your Your local service company.
	4. Cabinet expansion valve set too low.	4. Contact your Your local service company.
<b>Mix sours in cabinet.</b>	1. Cabinet thermostat defective, set too warm or tuned off.	1. Contact your Your local service company.
	2. Cabinet solenoid defective (does not open).	2. Contact your Your local service company.
	3. Cabinet switch defective.	3. Contact your Your local service company.
	4. Door switch defective.	4. Contact your Your local service company.
	5. Cabinet compressor contactor coil open (mix sours in night mode only.	5. Contact your Your local service company.
	6. Faulty time delay.	6. Contact your Your local service company.
	7. Suction pressure too low.	7. Contact your Your local service company.

## 14.1 MTS Troubleshooting Tables

PROBLEM	PROBABLE CAUSE	REMEDY
<b>Mix leaks out of MTS.</b> 	1. Transfer hose worn or split.	1. Remove cover, clean inside MTS around rollers with spray bottle provided. Install new hose. Do not twist hose.
<b>Mix transfer system (MTS) will not operate.</b> 	1. Pump cover not installed. 2. Hose not installed properly. 3. Slide switch defective. 4. MTS relay defective. 5. Start capacitor defective or motor start switch defective. 6. Pressure switch defective. 7. Motor defective or internal overload tripped.	1. Install cover. 2. Check position – reinstall. 3. Contact your Your local service company. 4. Contact your Your local service company. 5. Contact your Your local service company. 6. Contact your Your local service company. 7. Contact your Your local service company.
<b>MTS will not shut off.</b> 	1. Hose broken. 2. Pressure switch stuck in closed position.	1. Replace hose. 2. Contact your Your local service company.
<b>MTS cycles on and off without dispensing.</b> 	1. Worn transfer hose. 2. Leak on pressure side of system.	1. Replace hose. 2. Contact your Your local service company.
<b>MTS will not prime.</b> 	1. Insufficient supply of mix. 2. Swing clamp knob loose. 3. Air hose or air meter not installed. 4. Hose not installed.	1. Replenish mix supply. 2. Tighten knob. 3. Install air hose/air meter. 4. Install hose.
<b>Mix pickup tube loses prime.</b> 	1. Defective or missing duckbill valve. 2. Inlet clamp not tight. 3. Worn transfer hose.	1. Replace duckbill valve. 2. Tighten clamp. 3. Replace transfer hose.

## 14.1 MTS Troubleshooting Tables

PROBLEM	PROBABLE CAUSE	REMEDY
<b>No air (overrun).</b> 	1. Air meter plugged.	1. Clean or replace air meter.
	2. Air tube pinched.	2. Replace tube.
<b>Too much air, overrun too high – popping problems.</b> 	1. Air meter too large.	1. Install smaller air meter.
	2. Air leak between pickup tube and hose.	2. Replace as needed.
	3. Air line hose cracked – sucking air.	3. Replace air line hose.
	4. Defective or missing duckbill valve.	4. Replace valve.
<b>Mix shoots out air meter.</b> 	1. Swing Clamp knob loose.	1. Tighten.
	2. Transfer hose worn.	2. Replace hose.
	3. MTS pressure too high.	3. Contact your local service company.

**Keep your freezer in excellent condition — always contact your H.C. Duke & Son, LLC. Distributor for replacement parts and maintenance scheduling.**

**QUALITY PARTS  
PROTECT  
YOUR  
INVESTMENT**

*NOTE: Contact your authorized H.C. Duke & Son, LLC. Distributor for instructions prior to warranty compressor replacement.*

## 15 VQM Error Codes

Error Code	Description/Action	Probable Cause	Remedy
<b>MAIN COMM</b>	<p>The Main P.C. Board has stopped receiving messages from the User Interface</p> <p>Action: System shut down completely.</p> <p>Reset Method: Auto, once condition is rectified.</p>	<p>1. Faulty Wire Connection</p> <p>2. Programming Issue</p> <p>3. Defective Board</p>	<p>1. Check Communication cable between Main P.C. board and U.I. board. (Contact H.C. Duke &amp; Son Factory Tech Support)</p> <p>2. Ensure U.I. Program version and Main P.C. Program Version are compatible. (Contact H.C. Duke &amp; Son Factory Tech Support Software version compatibility)</p> <p>3. If the program versions are compatible, and using the test cable does not resolve the issue then the main control board is not functioning properly and needs to be replaced. (Contact H.C. Duke &amp; Son Factory Tech Support)</p>
<b>NO COMM.</b>	<p>The U.I. Board is not receiving messages from the main board</p> <p>Action: System shut down completely.</p> <p>Reset Method: Auto, once condition is rectified.</p>	<p>1. Faulty Wire Connection</p> <p>2. Programming Issue</p> <p>3. Defective Board</p>	<p>1. Check Communication cable between Main P.C. board and U.I. board. (Contact H.C. Duke &amp; Son Factory Tech Support)</p> <p>2. Ensure U.I. Program version and Main P.C. Program Version are compatible. (Contact H.C. Duke &amp; Son Factory Tech Support)</p> <p>3. If the program versions are compatible, and using the test cable does not resolve the issue then the U.I. board is not functioning properly and needs to be replaced. (Contact H.C. Duke &amp; Son Factory Tech Support)</p>

## 15 VQM Error Codes (continued)

Error Code	Description/Action	Probable Cause	Remedy
<p><b>CYL RFG.</b></p>	<p>This error occurs when cylinder system run time exceeds 90 minutes. Cylinder switches to STBY mode and locks out.</p> <p>Action: Cylinder Refrigeration off, cabinet refrigeration continues to operate.</p> <p>Reset Method: Main Power Switch, once the condition has been rectified.</p>	<ol style="list-style-type: none"> <li>1. Dirty Condenser</li> <li>2. Shortage of Refrigerant</li> <li>3. Faulty wire connection</li> <li>4. Compressor starting components failure (1 Phase Only)</li> <li>5. Compressor Contactor Failure</li> <li>6. Compressor Contactor Control Relay not activating</li> <li>7. System lacks efficiency</li> <li>8. Faulty Thermistor</li> <li>9. Condenser Fan Motor Failure (Air Cooled Only)</li> </ol>	<ol style="list-style-type: none"> <li>1. Clean Condenser</li> <li>2. Locate Source of refrigerant leak and repair.</li> <li>3. Locate faulty connection (Wire rubbed through, cut) and repair as needed.</li> <li>4. Check Compressor Starting components and replace as needed.</li> <li>5. Check contactor coil for proper resistance, check for voltage drop across contact points. Replace as needed</li> <li>6. Check to see if Relay is receiving power from Main P.C. board (12VDC), Ohm relay control coil for proper resistance. Replace relay as needed. If no 12VDC is detected Contact H.C. Duke &amp; Son Factory Tech Support.</li> <li>7. Check for worn blades, AXV pressure settings, Check water regulating valve setting (Water Cooled), check refrigerant level, compressor efficiency.</li> <li>8. Remove thermistor, check in ice water and compare to thermistor curve chart. If faulty replace, if thermistor tests o.k. check wire harness connections. If all connections are sound possibility of control board issue. (Contact H.C. Duke &amp; Son for proper compressor oil charge)</li> <li>9. Replace Condenser fan motor</li> </ol>

## 15 VQM Error Codes (continued)

Error Code	Description/Action	Probable Cause	Remedy
<b>CYL RFG.</b>	<p>This error occurs when cylinder system run time exceeds 90 minutes. Cylinder switches to STBY mode and locks out.</p> <p>Action: Cylinder Refrigeration off, cabinet refrigeration continues to operate.</p> <p>Reset Method: Main Power Switch, once the condition has been rectified.</p>	<p>10. Water Flow Restriction (Water Cooled Only)</p> <p>11. AXV not set properly/not responding</p> <p>12. Compressor Failure/ Reduced Capacity</p> <p>13. Moisture in system</p> <p>14. Compressor Control Relay not activating</p>	<p>10. Locate and remove restriction, re-start system to check for further issues</p> <p>11. Check System refrigerant level, attempt to re-set AXV valve pressure. If valve is not responsive, it may need to be replaced</p> <p>12. Check Voltage to the unit to ensure it is within specification, Check wire connections to the unit and compressor, Check compressor contactor for loose wire connections and proper operation, and possible voltage drop, ohm compressor windings to check for a short and proper winding resistance, check compressor starting components for failure, allow compressor protector to reset and check for proper amp draw.</p> <p>13. Recover refrigerant, change filter drier, change compressor oil (Contact H.C. Duke &amp; Son for proper compressor oil charge), Evacuate system to a minimum of 200 microns or less. Repeat if necessary</p> <p>14. Check to see if Relay is receiving power from Main P.C. board (12VDC), Ohm relay control coil for proper resistance. Replace relay as needed. If no 12VDC is detected Contact H.C. Duke &amp; Son Factory Tech Support.</p>
<b>CABINET RFG</b>	<p>Occurs when cabinet refrigeration system run time exceeds 90 minutes</p> <p>Action: Cylinder refrigeration switches to standby mode, cabinet refrigeration is turned off.</p> <p>Reset Method: Main Power Switch, once the condition has been rectified.</p>	<p>1. Dirty Condenser</p> <p>2. Shortage of Refrigerant.</p> <p>3. Evaporator coil Froze up</p> <p>4. Cabinet TXV superheat not set properly</p>	<p>1. Clean Condenser</p> <p>2. Locate Source of refrigerant leak and repair.</p> <p>3. Check door gasket for wear, check evaporator fan motor for proper operation, check spring loaded door closer for proper operation.</p> <p>4. Ensure the Cabinet TXV Superheat is at 10 to 12 degrees once the system is close to set point. Adjust if necessary</p>

## 15 VQM Error Codes (continued)

Error Code	Description/Action	Probable Cause	Remedy
<b>CABINET RFG (cont.)</b>	<p>Occurs when cabinet refrigeration system run time exceeds 90 minutes</p> <p>Action: Cylinder refrigeration switches to standby mode, cabinet refrigeration is turned off.</p> <p>Reset Method: Main Power Switch, once the condition has been rectified.</p>	5. Faulty wire connection	5. Locate faulty connection (Wire rubbed through, cut) and repair as needed.
		6. Restriction in System i.e. Capillary tube, Filter Drier	6. Locate restriction and repair as needed.
		7. Faulty Thermistor	7. Remove thermistor, check in ice water and compare to thermistor curve chart. If faulty replace, if thermistor tests o.k. check wire harness connections. If all connections are sound possibility of control board issue. (Contact H.C. Duke & Son Factory Tech Support)
		8. Compressor Control Relay not activating	8. Check to see if Relay is receiving power from Main P.C. board (12VDC), Ohm relay control coil for proper resistance. Replace relay as needed. If no 12VDC is detected Contact H.C. Duke & Son Factory Tech Support.
		9. Compressor starting components failure	9. Check Compressor Starting components and replace as needed.
		10. Compressor failure/reduced capacity	10. Check Voltage to the unit to ensure it is within specification, Check wire connections to the unit and compressor, Check compressor contactor for proper operation, and possible voltage drop, ohm compressor windings to check for a short and proper winding resistance, check compressor starting components for failure, allow compressor protector to reset and check for proper amp draw.
		11. Moisture in System	11. Recover refrigerant, change filter drier, change compressor oil (Contact H.C. Duke & Son for proper compressor oil charge), Evacuate system to a minimum of 200 microns or less. Repeat if necessary

## 15 VQM Error Codes (continued)

Error Code	Description/Action	Probable Cause	Remedy
<b>CYL. TEMP</b>	<p>Occurs when barrel thermistor is above or below temp. limit for 1 minute without change</p> <p>Action: Affected barrel is in STBY time cycle mode (1min on and 40 min. off), Cabinet refrigeration remains on</p>	<ol style="list-style-type: none"> <li>1. Faulty wire connection</li> <li>2. Faulty Thermistor</li> </ol>	<ol style="list-style-type: none"> <li>1. Locate faulty connection (Wire rubbed through, cut) and repair as needed.</li> <li>2. Remove thermistor, check in ice water and compare to thermistor curve chart. If thermistor does not ohm correctly, replace thermistor.</li> </ol>
<b>CABINET TEMP.</b>	<p>Occurs when cabinet thermistor is above or below temp. limit for 1 minute without change</p> <p>Action: Cabinet is in time cycle mode (5 min. on and 30 min. off) both cylinders are in standby mode.</p> <p>If unit is in cabinet only mode: Cabinet is in time cycle mode and both cylinders remain off</p>	<ol style="list-style-type: none"> <li>1. Faulty wire connection</li> <li>2. Faulty Thermistor</li> <li>3. Program Issue</li> </ol>	<ol style="list-style-type: none"> <li>1. Locate faulty connection (Wire rubbed through, cut) and repair as needed.</li> <li>2. Remove thermistor, check in ice water and compare to thermistor curve chart. If thermistor does not ohm correctly, replace thermistor.</li> <li>3. Ensure U.I. Program version and Main P.C. Program Version are compatible. (Contact H.C. Duke &amp; Son Factory Tech Support)</li> </ol>
<b>HEAD SW (Head Switch)</b>	<p>Occurs when head switch is open with power applied to unit</p> <p>Action: Affected cylinder is turned off.</p> <p>Reset Method: Auto, once condition has been rectified</p>	<ol style="list-style-type: none"> <li>1. Head Assembly Not installed</li> <li>2. Faulty Head switch (1 per cylinder)</li> <li>3. Faulty wire connection</li> <li>4. Magnet removed from Head assy.</li> </ol>	<ol style="list-style-type: none"> <li>1. Install Head assembly</li> <li>2. Test head switch to see if circuit remains open with magnet in place, remove and replace head switch as needed</li> <li>3. Locate Faulty wire connection and repair as needed</li> <li>4. Replace the head assy.</li> </ol>

## 15 VQM Error Codes (continued)

Error Code	Description/Action	Probable Cause	Remedy
<b>MOTOR OVLD</b>	<p>Occurs when motor current is 0, and the computer is calling for the motor to operate.</p> <p>Action: Affected barrel is off, hopper refrigeration continues to operate.</p> <p>Reset Method: Main Power Switch, once the condition has been rectified.</p>	<ol style="list-style-type: none"> <li>1. Motor internal overload open</li> <li>2. Faulty wire connection</li> <li>3. Motor Contactor Failure</li> <li>4. Motor control relay not activating</li> <li>5. Motor Failure</li> <li>6. Current Sense board/function failure</li> <li>7. One line of power loss</li> <li>8. Program Issue</li> </ol>	<ol style="list-style-type: none"> <li>1. Allow motor to cool and overload to reset, Check motor start components, product temperature (Too cold, low overrun), and gear reducer operation.</li> <li>2. Locate Faulty wire connection and repair as needed</li> <li>3. Check contactor coil for proper resistance, check for voltage drop across contact points. Replace as needed</li> <li>4. Check to see if Relay is receiving power from Main P.C. board (12VDC), Ohm relay control coil for proper resistance. Replace relay as needed. If 12 VDC is not detected Contact H.C. Duke &amp; Son Factory Tech Support</li> <li>5. Check motor starting components, check motor for shorts to ground, check for proper winding resistance. Replace Motor as needed</li> <li>6. Check current sense board wire connections, check max current setting in control system. (Contact H.C. Duke &amp; Son Factory Tech Support)</li> <li>7. Check main power supply, and main wire connections and correct as needed</li> <li>8. Ensure U.I. Program version and Main P.C. Program Version are compatible. (Contact H.C. Duke &amp; Son Factory Tech Support)</li> </ol>

## 15 VQM Error Codes (continued)

<p><b>COMP. LO PSI</b></p>	<p>Occurs when low pressure control is activated.</p> <p>Action: Cylinder refrigeration is off, Cabinet refrigeration Continues to operate.</p> <p>Reset Method: Main Power Switch, once the condition has been rectified.</p>	<ol style="list-style-type: none"> <li>1. System is Short on refrigerant</li> <li>2. Solenoid valve not activating</li> <li>3. Low pressure control is Faulty.</li> <li>4. Restriction is refrigeration system.</li> <li>5. Faulty wire connection.</li> <li>6. System component failure</li> </ol>	<ol style="list-style-type: none"> <li>1. Locate refrigerant leak and repair as needed. Ensure refrigeration system is evacuated to at least 200 microns.</li> <li>2. Determine if Solenoid coil is receiving proper voltage (208/230 Volts), If coil is receiving voltage, ohm out coil windings. If coil is not receiving voltage, check relay responsible for activating coil and repair as needed.</li> <li>3. Confirm Low pressure control is faulty by installing manifold gauges to confirm suction pressure is above cut-in set point of control. Replace control as needed</li> <li>4. Locate and remove restriction i.e. restricted drier, AXV closed down, Solenoid valve not opening etc.</li> <li>5. Repair connection as needed i.e. faulty connection on LPCO, etc.</li> <li>6. Locate failed component (Diagnostics Mode in Technician Menu will aid in locating) i.e. solenoid coil, AXV valve not opening, control relay, Compressor contactor staying energized causing unit to pump down, etc. and repair as needed.</li> </ol>
<p><b>COMP. HIGH PSI</b></p>	<p>Occurs when the High pressure control is activated.</p> <p>Action: Cylinder refrigeration is off, Cabinet refrigeration Continues to operate</p> <p>Reset Method: Main Power Switch, once the condition has been rectified.</p>	<ol style="list-style-type: none"> <li>1. Dirty Condenser Air Cooled</li> <li>2. Bad Condenser Fan Motor (A/C Only)</li> <li>3. Dirty Condenser (Water Cooled)</li> </ol>	<ol style="list-style-type: none"> <li>1. Blow out and clean Air cooled condenser re-start system and check unit operation.</li> <li>2. Replace Condenser motor as needed. Check system operation</li> <li>3. Check inlet and outlet water temperature on condenser, it should be at least 20°F difference from inlet to outlet. If there is no temperature change, condenser is fouled out and will need to be cleaned, or changed. If this condition is present, contact the H.C. Duke &amp; Son Technical Support Line.</li> </ol>

## 15 VQM Error Codes (continued)

Error Code	Description/Action	Probable Cause	Remedy
<p><b>COMP. HIGH PSI (cont.)</b></p>	<p>Occurs when the High pressure control is activated.</p> <p>Action: Cylinder refrigeration is off, Cabinet refrigeration Continues to operate</p> <p>Reset Method: Main Power Switch, once the condition has been rectified.</p>	<p>4. High Pressure control is Faulty.</p> <p>5. Faulty Wire Connection</p> <p>6. Non-Condensables in refrigeration system.</p> <p>7. Refrigeration System over charged.</p>	<p>4. Confirm High pressure control is faulty by installing manifold gauges to confirm high side pressure is below cut-out set point of control. Replace control as needed.</p> <p>5. Repair connection as needed i.e. faulty connection on HPCO, etc.</p> <p>6. Fully recover refrigerant from system, change the refrigerant filter/drier, evacuate system to at least 200 microns and weigh in Factory refrigerant charge (Contact H.C. Duke &amp; Son in charge amount is not stated on machine data Plate). Ensure while evacuating system a manual activation magnet is placed on each solenoid to ensure they are open for a full system evacuation. Start system and check operation</p> <p>7. Fully recover refrigerant from system, change the refrigerant filter/drier, evacuate system to at least 200 microns and weigh in Factory refrigerant charge (Contact H.C. Duke &amp; Son if charge amount is not stated on machine data Plate). Start system and check operation</p>
<p><b>CLOCK ERROR</b></p>	<p>CLOCK ERROR</p> <p>Action: All timer functions use default data/time</p>	<p>Contact H.C. Duke &amp; Son Technical Support Line if this Problem exists</p>	<p>Contact H.C. Duke &amp; Son Technical Support Line if this Problem exists.</p>

## 15 VQM Error Codes (continued)

Error Code	Description/Action	Probable Cause	Remedy
<b>POWER FAIL</b>	<p>Displays Power Fail if main power to system has failed</p> <p>Action: If unit is in Freeze or STBY mode, unit will restore in STBY Mode. If unit is in Clean or Off Mode, unit will restore in Off Mode.</p> <p>Reset Method: Auto, once the condition has been rectified. Power Fail will be displayed on screen until user presses enter button to acknowledge loss of main power.</p>	<p>1. Main Incoming power to unit was disrupted</p>	<p>1. Check all main power connections, Transformer switch to 208 Volt for 220Volt and below and 230 Volt for 220 Volt and above.</p> <p>2. Check 24VAC connections to control board, ensure all 24VAC connections are secure.</p>
<b>SPIGOT</b>	<p>Displays Spigot if the Left or Right Side Spigot switch is engaged for more than 5 minutes.</p> <p>Action: Affected side compressor and beater motor are off.</p> <p>Reset Method: Auto, once the condition has been rectified.</p>	<p>1. Spigot Push rod not installed</p> <p>2. Spigot switch has failed in the closed position</p> <p>3. Spigot Switch is out of adjustment</p> <p>4. Plunger is sticking open</p>	<p>1. Install Spigot Push Rod and start system to see if error is eliminated.</p> <p>2. Replace defective spigot switch and ensure new switch is adjusted properly.</p> <p>3. Re-adjust Spigot switch to operate properly with Push Rod.</p> <p>4. Check for proper lubrication, o-ring wear, switch tower spring worn causing plunger to not close, etc.</p>
<b>C SPIGOT</b>	<p>Displays C Spigot if the Center spigot switch is engaged for more than 5 minutes</p> <p>Action: Affected side compressor and beater motor are off.</p> <p>Reset Method: Auto, once the condition has been rectified.</p>	<p>1. Spigot Push rod not installed</p> <p>2. Spigot switch has failed in the closed position</p> <p>3. Spigot Switch is out of adjustment</p> <p>4. Plunger is sticking open</p>	<p>1. Install Spigot Push Rod and start system to see if error is eliminated.</p> <p>2. Replace defective spigot switch and ensure new switch is adjusted properly.</p> <p>3. Re-adjust Spigot switch to operate properly with Push Rod.</p> <p>4. Check for proper lubrication, o-ring wear, switch tower spring worn causing plunger to not close, etc.</p>

## 15 VQM Error Codes (continued)

Error Code	Description/Action	Probable Cause	Remedy
<b>L PWR OFF</b>  (This error only applies to Dual Power supply units)	Displays L POWER OFF if the Power good relay is not energized, for the A/Left side of dual power supply machines.  Action: Left side of unit is off, and the right side is operational  Reset Method: Auto, once the condition has been rectified.	1. Main power to left side is off  2. Power good relay has failed  3. Faulty wire connection to power good relay.  4. Control board issue.	1. Check to see if main circuit breaker is tripped or unit's main power cord is not installed properly.  2. Check coil on power good relay with ohm meter. If open electrically replace relay.  3. Check high voltage wire connections to power good relay. Check low voltage connections going from relay to main control board. Check continuity through relay contacts to ensure proper operation. Repair any connections as needed.  4. Contact H.C. Duke & Son Technical Support
<b>PUMP HI PSI</b>	Displays Pump Hi PSI if the pump pressure is greater than 40 PSI for 10 seconds while pump is on.  Action: Affected pump is turned off  Reset Method: Main Power Switch, once the condition has been rectified.  Note: If unit trips this error and Pressure relief has not opened, check to ensure relief is functioning properly.	1. Pump control relay is stuck closed causing pump motor to stay energized.  2. Faulty Pressure transducer/out of calibration.  3. Faulty Control Board	1. Test to see if coil voltage is present at pump control relay, If it is not and pump is still running, the control relay is stuck and needs to be replaced. If coil voltage is present then control board or Transducer may be malfunctioning.  2. Attempt to calibrate the Transducer to 0 psi and re-test unit. If unit continues to malfunction contact H.C. Duke & Son Technical Support.  3. Contact H.C. Duke & Son Technical Support.

## 15 VQM Error Codes (continued)

Error Code	Description/Action	Probable Cause	Remedy
<b>PUMP ERROR</b>  (Formerly PUMP LO PSI)	<p>Displays Pump Error if the pump has ran for 2 minutes continually while in freeze mode.</p> <p>Action: Affected pump is turned off, along with the affected cylinder being turned to standby</p> <p>Reset Method: Main Power Switch, once the condition has been rectified.</p>	<ol style="list-style-type: none"> <li>1. Mix Bag has been siphoned out completely without being changed</li> <li>2. Duck bill check valve is not installed in the bag connector</li> <li>3. Pump transfer hose is worn out.</li> <li>4. Leaking Pressure Relief System</li> <li>5. Pump control relay not closing preventing pump motor from running</li> <li>6. Pump motor Starting components Faulty</li> <li>7. Faulty wire connection</li> <li>8. Pressure Transducer is Faulty</li> <li>9. Faulty Control Board</li> </ol>	<ol style="list-style-type: none"> <li>1. Ensure the mix bag is changed and using the main power switch, reset the machine to return it to normal operation. <b>Please Note: If the mix bag is not checked when the machine shows a mix out condition the Pump Error will occur frequently.</b></li> <li>2. Install the Duck bill check valve</li> <li>3. Replace pump transfer hose (Should be replaced minimally every 30 days)</li> <li>4. Check to ensure swing arm is tightened properly. Also check to ensure spring has not become compressed.</li> <li>5. Test to see if coil voltage is present at pump control relay, If it is present but the pump will not start, check to see if the relay contacts are closing. If so move on to troubleshooting the pump motor. If not replace the relay and check operation.</li> <li>6. Remove and test pump Start capacitor and starting relay, Replace faulty parts as needed. Check motor windings to ensure no electrical shorts are present. Start unit and check operation.</li> <li>7. Locate and repair faulty wire connections as needed.</li> <li>8. Attempt to calibrate the Transducer to 0 psi and re-test unit. If unit continues to malfunction contact Electro Freeze Technical Support.</li> <li>9. Contact Electro Freeze Technical Support</li> </ol>

## 15 VQM Error Codes (continued)

Error Code	Description/Action	Probable Cause	Remedy
<b>SHORT</b>	<p>Displays SHORT when a thermistor has failed in a shorted state.</p> <p>Action: Affected System is cycled off.</p> <p>Reset Method: Auto once issue is corrected.</p>	<p>1. Faulty wire connection</p> <p>2. Faulty Thermistor</p>	<p>1. Check to ensure wires have not rubbed through and shorted out together or the wire harness is not resting in water.</p> <p>2. Change thermistor</p>
<b>OPEN</b>	<p>Displays OPEN when a thermistor has failed in an open state.</p> <p>Action: Affected system is cycled off</p> <p>Reset method: Auto once issue is corrected</p>	<p>1. Faulty wire connection</p> <p>2. Faulty Thermistor</p>	<p>1. Check to ensure Molex connectors are connected fully and that no wiring from the control board to the sensor has been severed.</p> <p>2. Change Thermistor</p>
<b>CYL. T ALARM</b>	<p>Displays CYL T ALARM when the cylinder temperature has reached 36 degrees for over 2 minutes.</p> <p>Action: Alarm is displayed only and will not change the state of the machine.</p> <p>Reset Method: The main power switch must be cycled to reset error.</p>	<p>Please refer to the error CYL RFG for troubleshooting.</p>	<p>Please refer to the error CYL RFG for troubleshooting.</p>
<b>CAB T ALARM</b>	<p>Displays CAB T ALARM when the cabinet temperature has exceeded 41 degrees for 15 minutes.</p> <p>Action: Alarm is displayed only and will not change the state of the machine.</p> <p>Reset Method: The main power switch must be cycled to reset error.</p>	<p>Please refer to the error CAB RFG for troubleshooting.</p>	<p>Please refer to the error CAB RFG for troubleshooting</p>

## 15 VQM Error Codes (continued)

Error Code	Description/Action	Probable Cause	Remedy
<b>CLEAN FINISHED</b>	<p>Displayed when the 4 parameters have been met for the machine to log a Last clean.</p> <p>Action: Displayed on the screen once the head is re-installed.</p> <p>Reset Method: Pressing the ENTER button will clear the display.</p>		<p>The 4 parameters to display Clean Finished are as follows:</p> <ol style="list-style-type: none"> <li>1. Head assy. removed for 10 minutes.</li> <li>2. Main Power switch needs to be turned off</li> <li>3. Cylinder temperature have to rise above 55 degrees.</li> <li>4. Both Mix transfer system pump covers need to be removed. If unit is a Gravity machine then the computer has to see a mix out condition.</li> </ol>
<b>PUMP COVER</b>	<p>Occurs if the RMT pump cover is removed or the cover switch is open.</p> <p>Action: If unit is in Freeze, the affected side will be turned to standby and the affected pump will be turned off. If unit is in clean or Standby mode the affected pump will be turned off and unit will not be allowed to be put into freeze, and will remain in standby or off.</p> <p>Reset Method: Auto, once the condition has been rectified.</p>	<ol style="list-style-type: none"> <li>1. Pump cover is not installed</li> <li>2. Pump cover magnet has been removed or fallen out</li> <li>3. Pump Cover safety switch is Faulty</li> <li>4. Faulty Wire Connection</li> <li>5. Program issue</li> </ol>	<ol style="list-style-type: none"> <li>1. Install Pump Cover</li> <li>2. Replace pump cover</li> <li>3. Test switch to confirm and replace as needed.</li> <li>4. Locate and repair faulty wire connections as needed.</li> <li>5. Contact H.C. Duke &amp; Son Technical Support</li> </ol>

## 15 VQM Error Codes (continued)

Error Code	Description/Action	Probable Cause	Remedy
<b>Main P.C. Board Heartbeat L.E.D not blinking/ U.I. Not Energizing</b>	Occurs if there is a power loss to the Main P.C. Board or a possible U.I. Issue	<ol style="list-style-type: none"> <li>1. Power Loss to Main P.C. Board</li> <li>2. Main P.C. Board Fuse blown</li> <li>3. Power Not being supplied to U.I. Board from main P.C. Board</li> <li>4. Faulty wire connection</li> </ol>	<ol style="list-style-type: none"> <li>1. Check control transformer for main 24 VAC power supply to main P.C. Board.</li> <li>2. Remove fuse and ohm to check for continuity, if none replace fuse. If once fuse is replaced and power is restored, the Main P.C. Board L.E.D. starts blinking however the U.I. Board does not energize then continue with this troubleshooting chart</li> <li>3. Remove communication wire from U.I. Board, This cable connects the U.I. Board to Main P.C. Board. Using a meter set to DC voltage and power to the Main P.C. Board on, test voltage across both Black wires. If voltage reads about 5.96 VDC then Main P.C. Board and the communication cable are working properly and the problem lies with the U.I. Board</li> <li>4. If 5.96 VDC is read on the black wires but the U.I. Board does not light up, the issue might lie with the communication cable, and that it is not making a good connection with the U.I. Board. Check the connector on the U.I. Board for damaged pins; also check the communication cable for loose wires in the cable connector (Contact H.C. Duke &amp; Son Factory Tech Support).</li> </ol>

If tested to the control board ground (Large aluminum plate on upper left side of Main Board) relay coil will read 12 VDC to ground and then zero VDC when activated, if tested across relay coil then it will read 0 VDC if sitting idle, and 12 VDC when activated.

If a Power Failure Occurs unit will log the change of state i.e. switching to night mode on re-start, when the unit is powered back up. The Power Failure error will be displayed on the screen until the SELECT button is pressed acknowledging the Failure. Once the SELECT button is pressed error will reset.

The Head Switch, Spigot Switch, Center Spigot Switch, Mix Low, and Mix Out Errors will all Auto Reset after the problem has been rectified.



**Keep your freezer in excellent condition — always contact your H.C. Duke & Son, LLC. Distributor for replacement parts and maintenance scheduling.**

**QUALITY PARTS**

**PROTECT**

**YOUR**

**INVESTMENT**

*NOTE: Contact your authorized H.C. Duke & Son, LLC. Distributor for instructions prior to warranty compressor replacement.*



**H. C. DUKE & SON, LLC.**  
2116-8th Avenue • East Moline, Illinois 61244

# REPLACEMENT PARTS MANUAL

with Illustrations

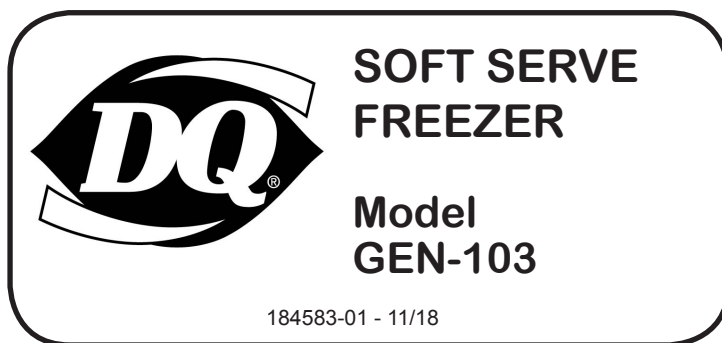



# ILLUSTRATIONS

Parts are listed on each page using terminology that best fits the function of the part. It is very important to know the serial number of the machine when ordering parts because many parts are not interchangeable from one serial number to another of the same model. The illustrations in this manual can be used as a reference for obtaining the correct part description and part number.

All parts listed in the manual should be ordered through:



H. C. Duke & Son, LLC  
2116 - 8th Avenue  
East Moline, Illinois 61244  
Telephone: (309) 755-4553 or (800) 755-4545  
Fax: (309) 755-9858  
E-mail: [service@hcduke.com](mailto:service@hcduke.com)

# PART II

## Replacement Parts

### Table of Contents

Figure 1	Head Assembly .....	1
Figure 2	Beater Shaft Assembly .....	2
Figure 3	MTS—RMT Hose Assembly.....	3
Figure 4	1 Ph Mix Transfer System — RMT.....	4
Figure 5	3 Ph Mix Transfer System — RMT.....	6
Figure 6	Cabinet Parts .....	8
Figure 7	Spigot Switch Assemblies .....	9
Figure 8	Capacitor & Relay Box.....	9
Figure 9	Switch Box .....	10
Figure 10	Panel Breakdown .....	12
Figure 11	Air Cooled Side/Back View .....	14
Figure 12	Water Cooled Side/Back View .....	16
Figure 13	Gear Reducer .....	18
Figure 14	Evaporator Mix Tube Assembly.....	19
Figure 15	Air Cooled Remote Condenser .....	20
	Accessories .....	21
	O-Ring Chart .....	23

**Figure 1 Head Assembly**

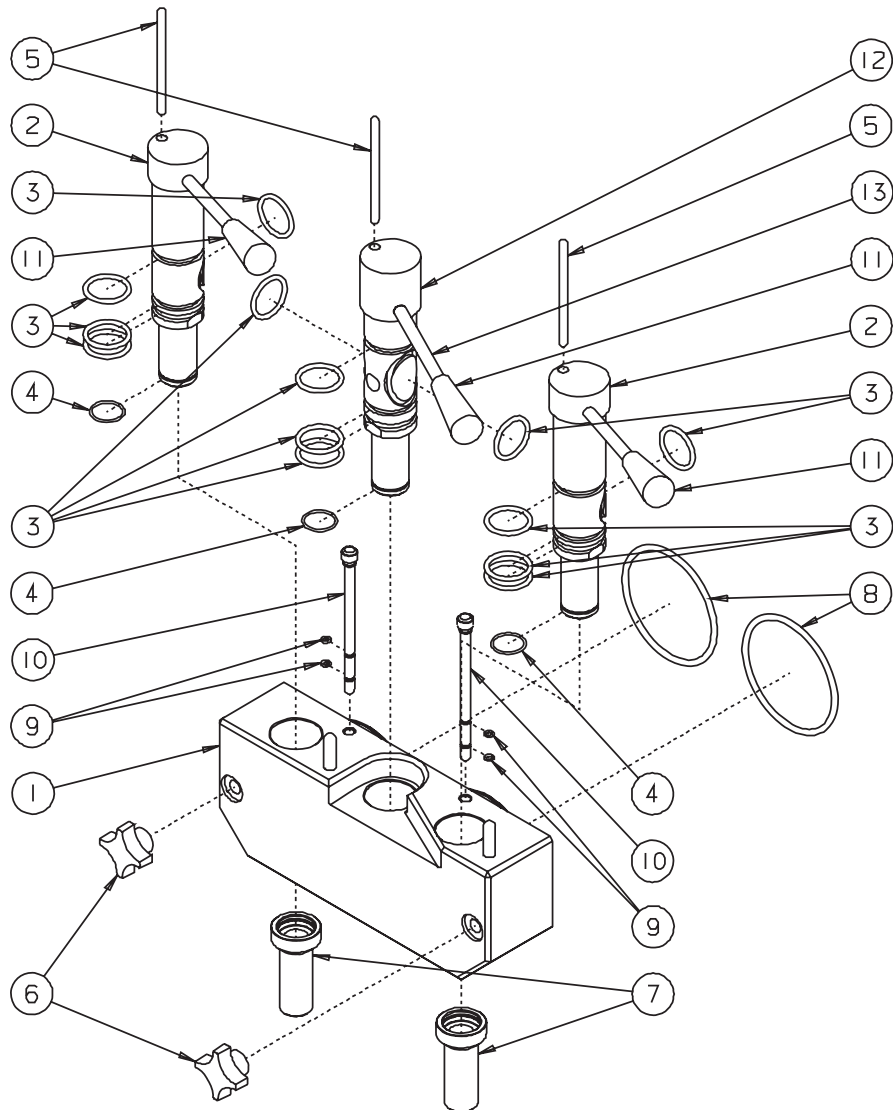

Item	Part No.	Description
*	HC119915	Head - Assy. Dispense (Complete)
1	HC119913	Head - Assy. w/Actuator (Less Parts)
2	HC118641	Spigot - Assy. Side w/Handle
3	HC159295	O-Ring (Spigot)
4	HC160584	O-Ring (Extension)
5	HC136794	Rod - Spigot Switch
6	HC162625	Knob - Hand
6A	HC114341-01	Stud - Assy. Cylinder 3-13/16"(not shown)
7	HC136713	Extension - Spigot
8	HC160583	O-Ring (4" Head)
9	HC160562	O-Ring (Air Bleed Plug)
10	HC115129	Bleeder - Assy.(Air Relief Plug)
11	HC162626	Handle - Tapered Black
12	HC137018	Spigot - Long Center (w/o handle)
13	HC136618	Rod - Handle, Center Spigot (Stainless Steel Extension only)

\* Includes items 1-4 and 8-13.

**Use only original or authorized replacement parts with this freezer.  
Use of unapproved parts will void warranty.**

## Figure 2 Beater Shaft Assembly

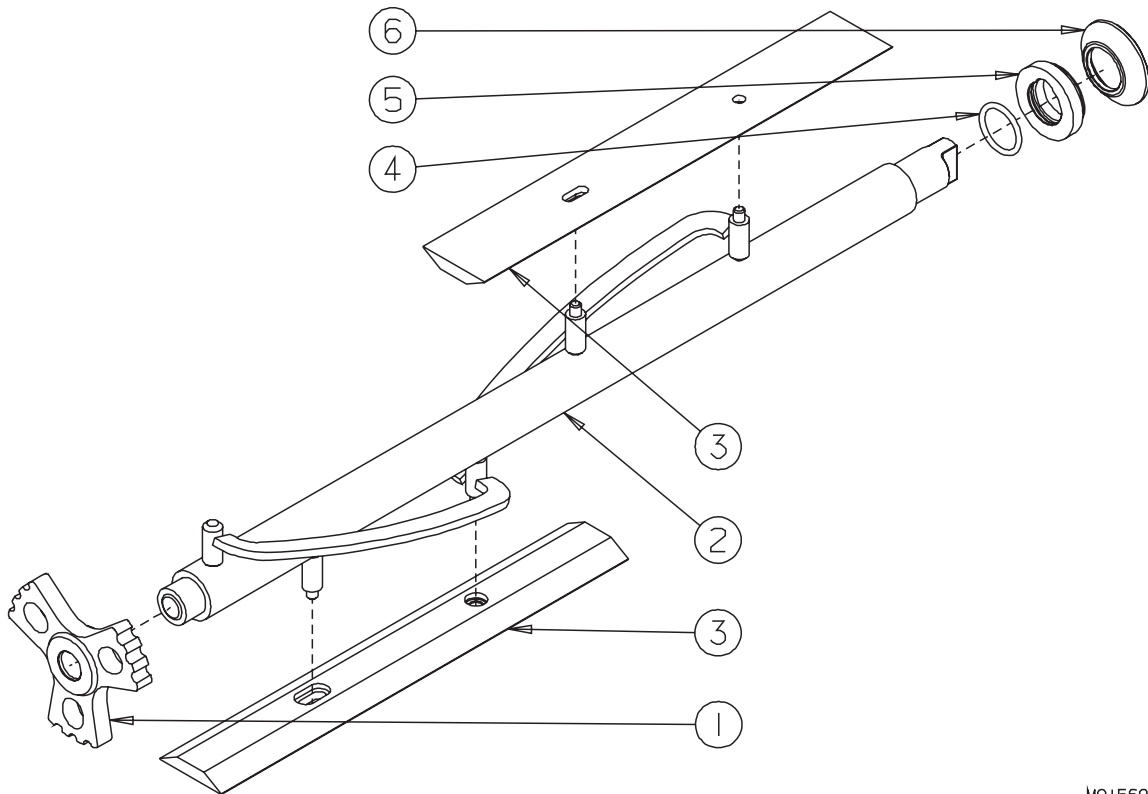

M01569

Item	Part No.	Description
1	HC196079	Bushing - Cylinder
2	HC113438-02	Shaft - Assy. Beater
3	HC137334	Blade - Scraper Soft Serve
4*	HC160500	O-Ring (Shaft Seal)
5*	HC133098	Washer - Shaft Seal
6*	HC160557	Seal - Beater Shaft

\*Item (4-6) HC111875..... Seal - Assy Shaft (Complete-3 piece shaft seal)

**Use only original or authorized replacement parts with this freezer.  
Use of unapproved parts will void warranty.**

**Figure 3 MTS—RMT Hose Assembly**

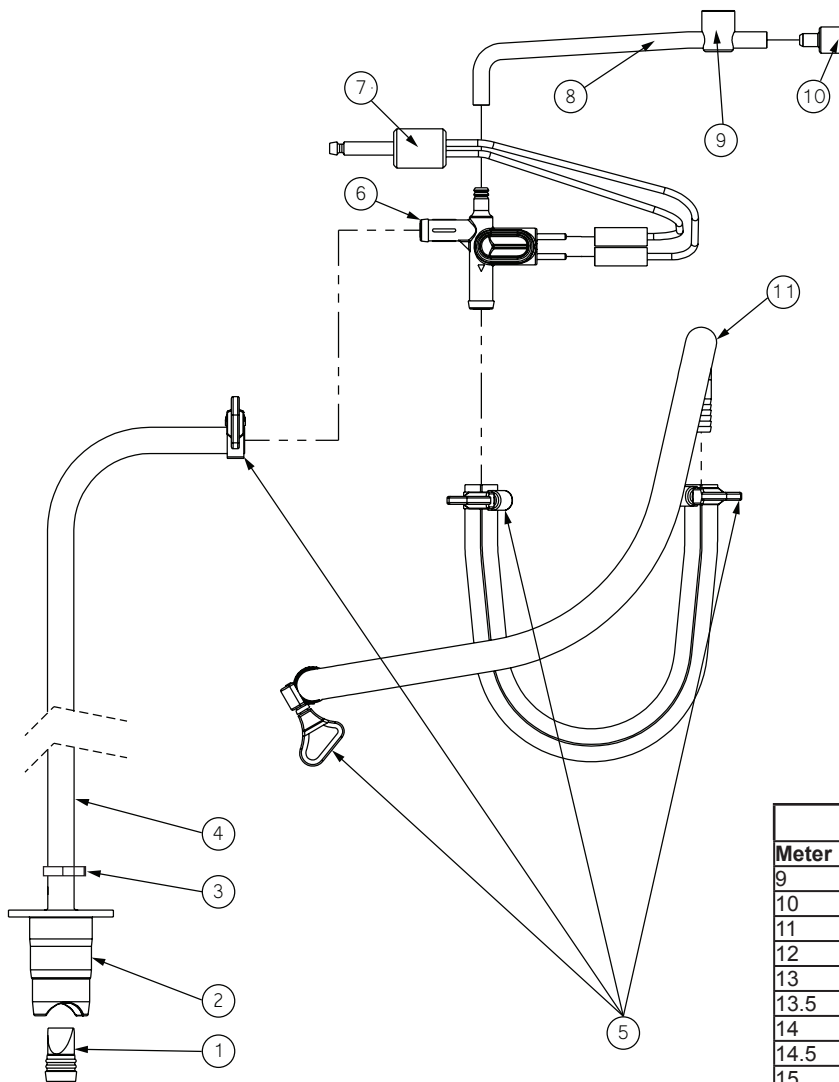

Item	Part No.	Description
1	HC199032	Duckbill - Inlet
2	HC138705-02	Connector - Bag In Box
3	HC160727	Clamp - Plastic Ratchet
4	HC196326	Tubing - Clear (Cut to Length)
5	HC116065	Clamp - Assy Soft Hose 5/8"
6	HC121799	Port - Assy Inlet Mix Level Molded
7	HC150016	Mix Cord
8	HC138170-02	Tube - Air
9	HC162324	Clip - Tube Retainer
10	Meter-Air	(Order by meter number)
11	HC121638	Hose - Assy Mix Braided

AIR METERS	
Meter No.	Part No.
9	HC163423
10	HC163424
11	HC163425
12	HC163426
13	HC163421
13.5	HC163421-05
14	HC163427
14.5	HC163427-05
15	HC163428
15.5	HC163428-05
16	HC163429
16.5	HC163429-05
17	HC163430
17.5	HC163430-05
18	HC163431
18.5	HC163431-05
19	HC163432
19.5	HC163432-05
20	HC163433
20.5	HC163433-05
21	HC163434
21.5	HC163434-05
22	HC163435
22.5	HC163435-05
23	HC163436
24	HC163437
25	HC163438
26	HC163439
28	HC163440
30	HC163441
31	HC163442

**Use only original or authorized replacement parts with this freezer.  
Use of unapproved parts will void warranty.**

Figure 4 1PH Mix Transfer System - RMT (Breakdown)

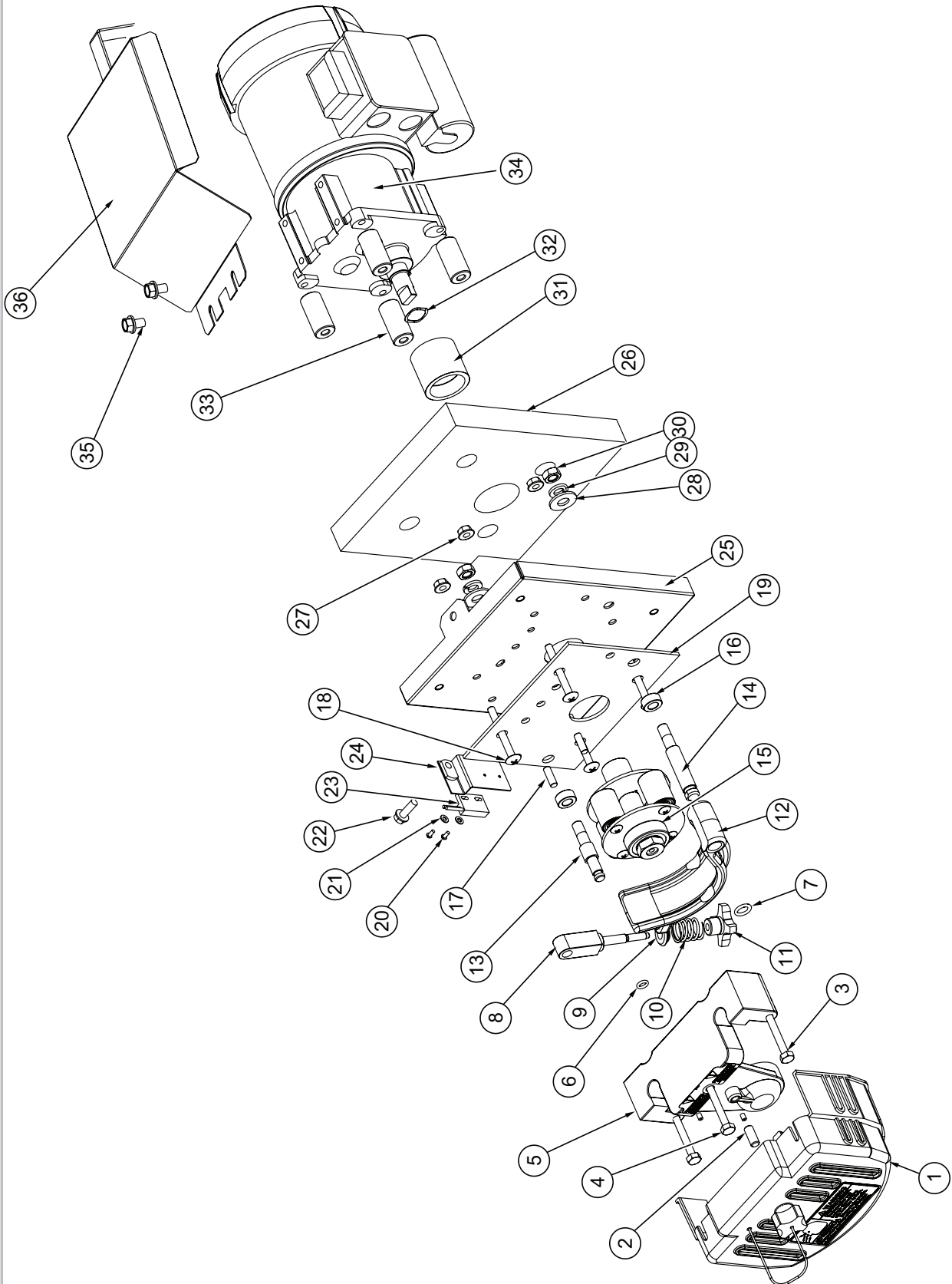

Use only original or authorized replacement parts with this freezer.  
Use of unapproved parts will void warranty.

**Figure 4 1PH Mix Transfer System - RMT (Parts)**

Item	Part No.	Description
*	HC118751-03	MTS - Assy Cab Red Line/Relief Bisn
1	HC121798	Cover - Assy RMT HC165246.....Decal - Warning Pressurized HC138889.....Knob - Cover RMT HC138890.....Lanyard - Wire HC160508.....Sleeve - Cable Stop 3/64
2	HC160386	Stud - 5/16-18 X 3/4 SST
3	HC160464	Screw - HXHC 1/4-20x2 1/2 SST
4	HC160465	Screw - HXHC 1/4-20x3 1/2 SST
5	HC138783-01	Support - Roller Bearing
6	HC160628	O Ring
7	HC160612	O Ring
8	HC120504	Clamp - Shoe Swing Base
9	HC140711	Washer - Spring End
10	HC162330	Spring - Compression
11	HC140706	Knob - Fluted 1/4-20 Custom
12	HC139751	Shoe - Roller
13	HC138799	Arm - Swing Clamp
14	HC138797	Arm - Shoe Pivot
15	HC116009	Roller - Assy Complete
16	HC138800	Spacer - Swing Arm
17	HC160338	Pin - Dowel 1/4 Dia X 3/4 SST
18	HC160093	Screw - TRPS 1/4-28x2-1/4 SST
19	HC191527	Blank - Backup MTS
20	HC160357	Screw - RDHM #4-40x1/4 Stl
21	HC160393	Washer - Flat #6 Brass
22	HC159939	Screw - HXSF 1/4-20x11/16 SST
23	HC161302	Switch - Slide/Cover
24	HC118763	Bracket - Assy Switch MNTG
25	HC118764	Faceplate - Assy MTS
26	HC165524	Block - Insulation RMT
27	HC159933	Nut - HXSF 1/4-20 SST
28	HC160169	Washer - Flat 3/8 SST
29	HC160170	Washer - Lock 3/8 SST
30	HC159927	Nut - Hex 3/8-16 SST
31	HC139756	Shield - Drip
32	HC160173	Washer - Spring Wave SST
33	HC138793	Spacer - Motor
34	HC121027	Kit - Gearmotor 1/6hp Replacement Model RMT Includes: HC139046-01....Gauge - Shaft Alignment RMT HC139839.....Strap - Mt Motor Rear HC160173.....Washer - Spring Wave SST
35	HC159919	Screw - HXWF #8-32 X 3/8 Zn
36	HC141607	Cover - RMT Pump Motor

\* Includes all items above.

**Use only original or authorized replacement parts with this freezer.  
Use of unapproved parts will void warranty.**

Figure 5 3PH Mix Transfer System - RMT (Breakdown)

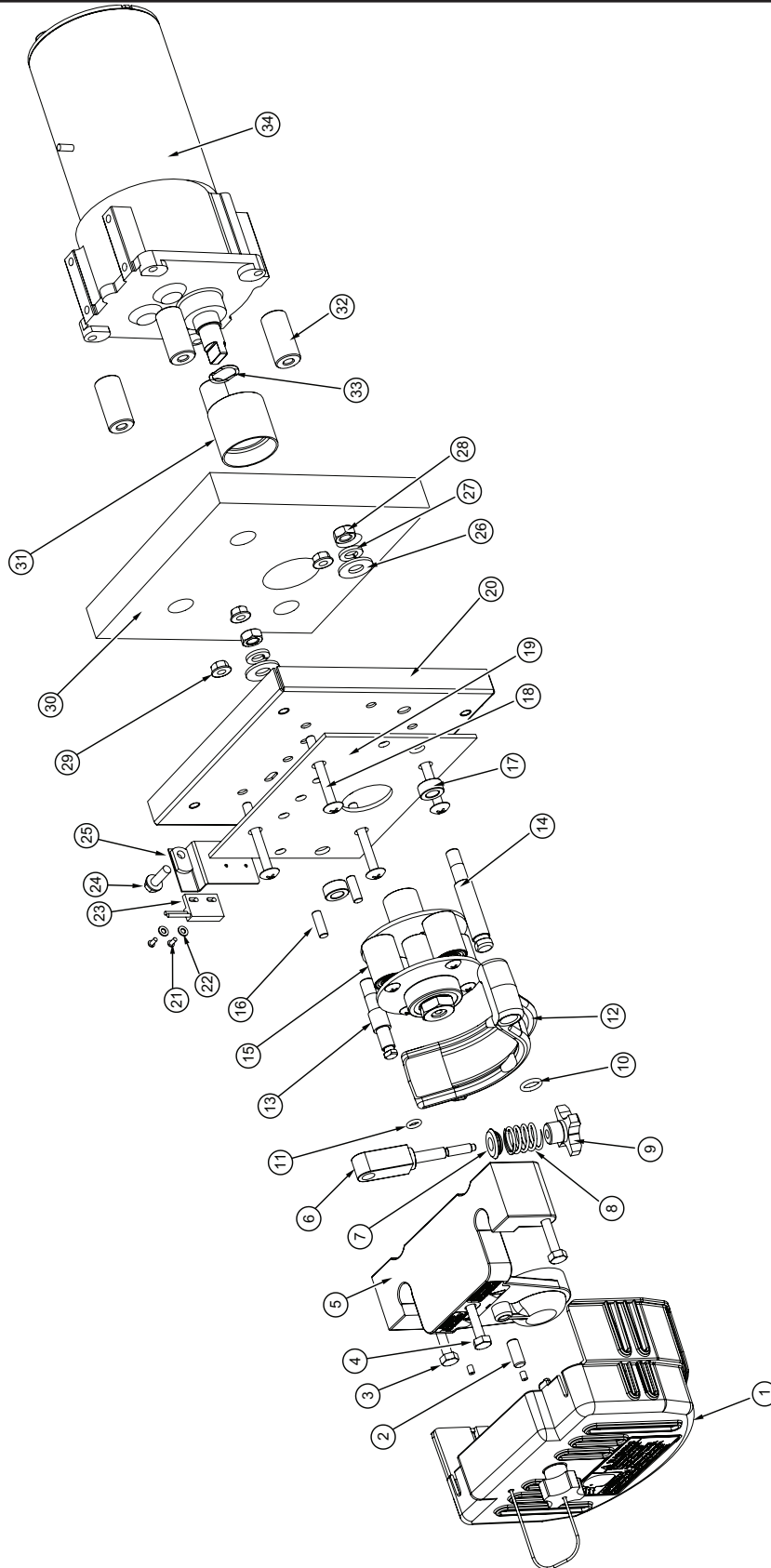

**Use only original or authorized replacement parts with this freezer.  
Use of unapproved parts will void warranty.**

## Figure 5 3PH Mix Transfer System - RMT (Parts)

Item	Part No.	Description
*	HC121634-03	MTS - Assy Cab Red Line/Relief Bisn (3 Phase)
1	HC121798	Cover - Assy RMT
	HC165246	Decal - Warning Pressurized
	HC138889	Knob - Cover RMT
	HC138890	Lanyard - Wire
	HC160508	Sleeve - Cable Stop 3/64
2	HC160386	Stud - 5/16 - 18 X 3/4 SST
3	HC160464	Screw - HXHC 1/4 - 20X2 1/2 SST
4	HC160465	Screw - HXHC 1/4 - 20X3 1/2 SST
5	HC120633	Support - Assy
6	HC120504	Clamp - Assy Swing 1/4 - 20
7	HC140711	Washer - Spring End
8	HC162330	Spring - Compression .79Diax1.51x.088SST
9	HC140706	Knob - Fluted 1/4 - 20 Custom
10	HC160612	O Ring
11	HC160628	O-Ring
12	HC139751	Shoe - Roller
13	HC138799	Arm - Swing Clamp
14	HC138797	Arm - Shoe Pivot
15	HC116009	Roller - Assy Bearing
16	HC160338	Pin - Dowel 1/4 Dia X 3/4 SST
17	HC138800	Spacer - Swing Arm
18	HC160093	Screw - Trps 1/4 - 28X2 - 1/4 SST
19	HC191527	Blank - Backup MTS
20	HC121633-01	Faceplate - Assy MTS Liner Right
21	HC160357	Screw - Rdhm #4 - 40X1/4 STL
22	HC160393	Washer - Flat #6 Brass
23	HC161302	Switch - Slide/Cover
24	HC159939	Screw - Hxsf 1/4 - 20X11/16 SST
25	HC118763	Bracket - Assy Switch Mntg
26	HC160169	Washer - Flat 3/8 SST
27	HC160170	Washer - Lock 3/8 SST
28	HC159927	Nut - Hex 3/8 - 16 SST
29	HC159933	Nut - Hxsf 1/4 - 20 SST
30	HC165524-01	Block - Insulation GES
31	HC139756	Shield - Drip
32	HC138793	Spacer - Motor
33	HC160173	Washer - Spring Wave SST
34	HC151161	Gearmotor - 1/8 Hp 208 - 230/3/60 270 RPM

\* Includes all items above.

**Use only original or authorized replacement parts with this freezer.  
Use of unapproved parts will void warranty.**

**Figure 6 Cabinet Parts**

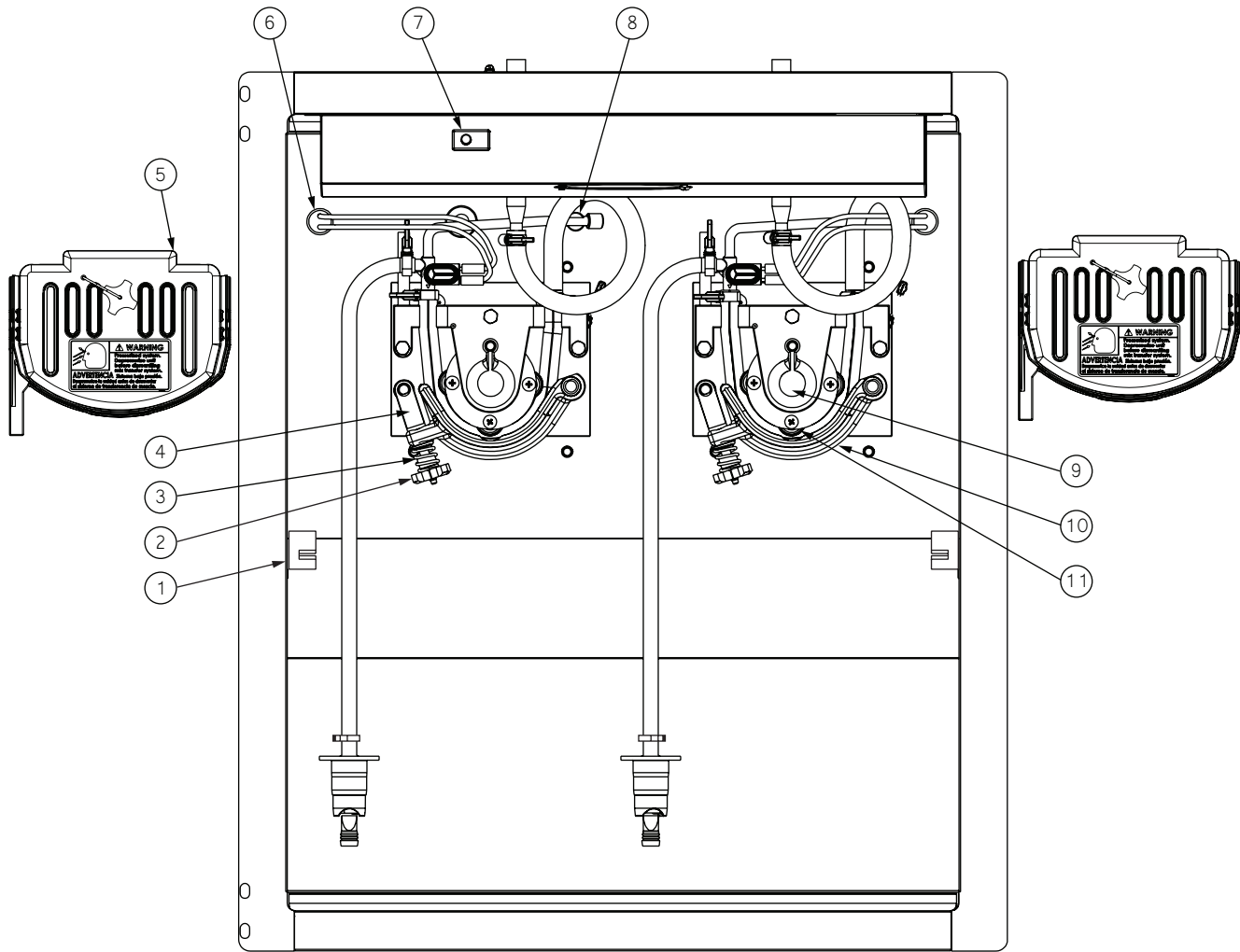

Item	Part No.	Description
1	HC161313	Switch - Proximity Reed NC
2	HC140706	Knob - Fluted 1/4-20 Custom
3	HC162330	Spring - Compression
3	HC140711	Washer - Spring End
4	HC138799	Arm - Swing Clamp
5	HC121798	Cover - Assy Mix Pump Molded
6	HC150536	Receptacle
7	HC150612	Switch
8	HC117092	Retainer - Air Line
9	HC138783-01	Support - Roller Bearing
10	HC139751	Shoe - Roller
11	HC116009-01	Roller - Assy Complete

**Use only original or authorized replacement parts with this freezer.  
Use of unapproved parts will void warranty.**

## Figure 7 Spigot Switch Assemblies

Item	Part No.	Description
*	HC113903	Switch - Assy. Spigot (Side)
1	HC150456	Switch - Snap Button
2	HC160393	Washer - Flat #6
3	HC160392	Washer - Ext. Tooth #6 ZN
4	HC160296	Screw - RDHM #6-32 x 1-1/4 SST
5	HC162321	Spring - Spigot Switch
6	HC136124	Button - Spigot Switch
7	HC160303	Ring - Retaining 1/2 External
8	HC113902	Bracket - Assy. Spigot Switch Mtg.
9	HC113901	Bracket - Assy. Adjusting
10	HC160267	Screw - RDHM #8-32 x 7/8 Brass
11	HC160102	Nut - HEX #8-32 ZN
12	HC135744	Insulator - Switch

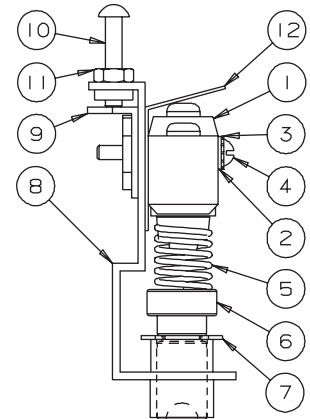

\* Includes items 1-12.

## Figure 8 Capacitor & Relay Box (1 phase)

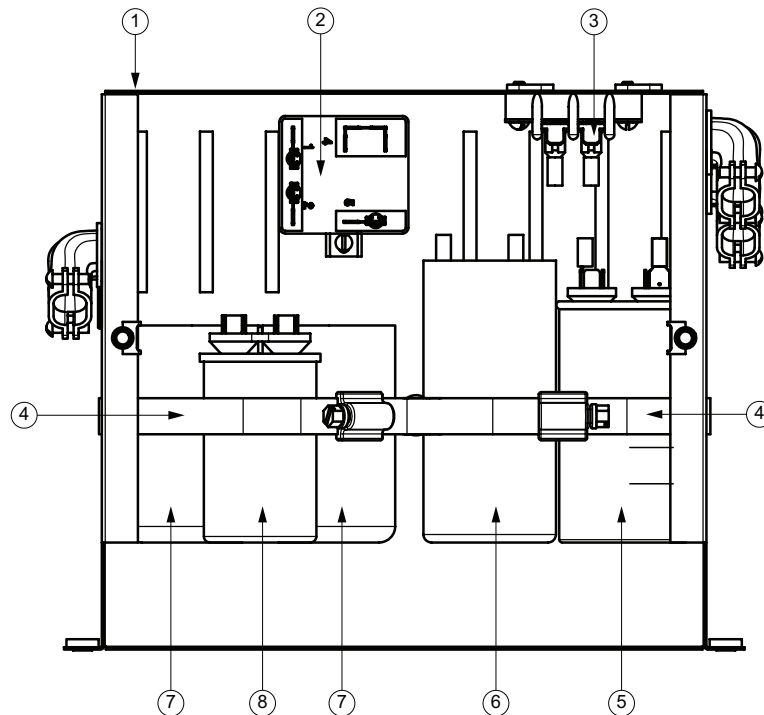

Item	Part No.	Description
1	HC120809-01	Box - Assy Cap & Relay Weldment
2	HC150029	Relay - Compressor COPZS
3	HC150798	Strip - Terminal
4	HC160739	Clamp - Hose 3 9/16-4 1/2, Screw
5	HC150403	Capacitor - Run
6	HC151445	Capacitor - Start
7	HC150294	Capacitor - Start
8	HC150244	Capacitor - Run

**Use only original or authorized replacement parts with this freezer.  
Use of unapproved parts will void warranty.**

# Figure 9 Switch Box (Breakdown)

## TOP VIEW

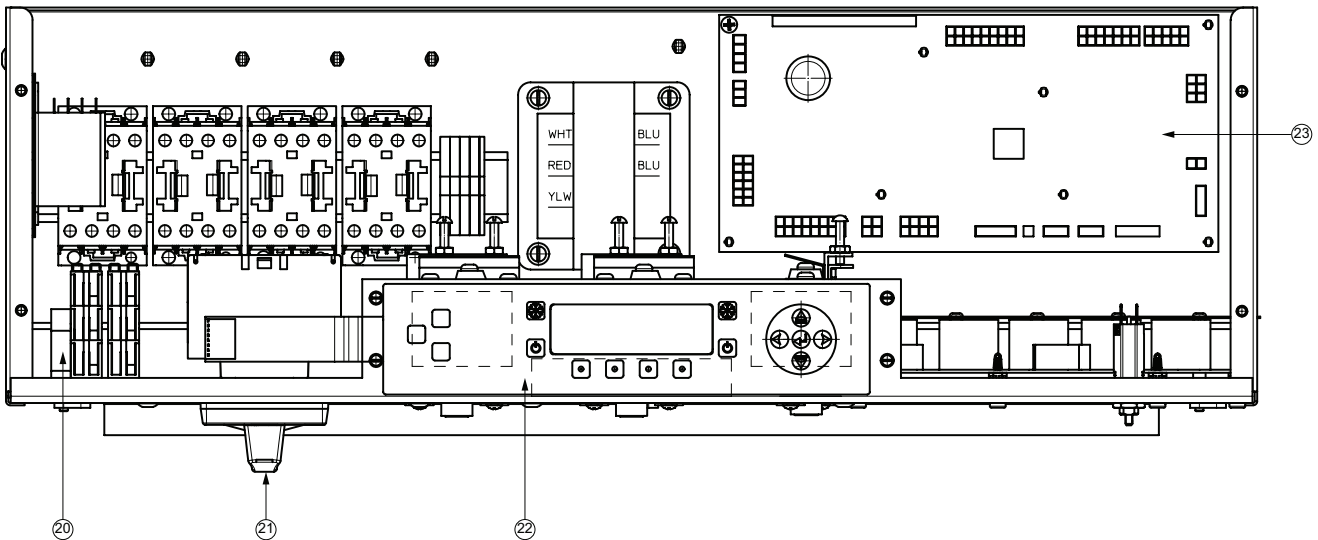
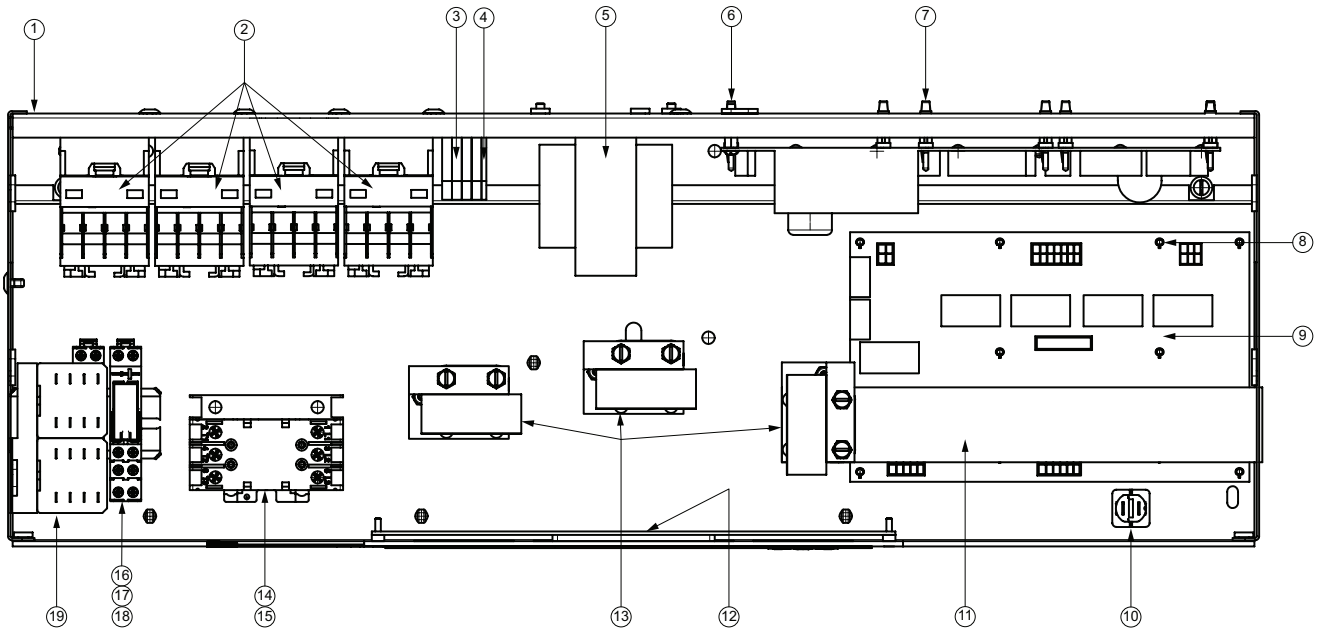

## FRONT VIEW

**Use only original or authorized replacement parts with this freezer.  
Use of unapproved parts will void warranty.**

## Figure 9 Switch Box (Parts)

Item	Part No.	Description
1	HC121272	Box - Assy Electrical Weldment
2	HC150076	Contacto – 3P 25A 24V Coil BF25
3	HC150591	Block - Terminal
4	HC150594	Stop - Terminal Block End
5	HC150181	Transformer - C12 208/240PRI/24SEC
6	HC160237	Standoff - Hex Male/Female #6-32 5/8
7	HC150927	Support - 5/8 Circuit Board
8	HC150038	Support - 1/2 Circuit Board
9	HC151702	Board - PC Relay
10	HC150182-01	Breaker - Circuit 4A Threaded
11	HC141350	Insulator - Relay Board
13	HC113903	Switch - Assy Spigot
14	HC151708	Switch - Disconnect
15	HC150994-05	Board - PCB UI B.5090
15	HC151708-01	Switch - Disconnect 4th Pole Add On
16	HC150098	Socket - Miniature Relay DPDT
17	HC150166	Clip - Miniature Relay Retaining
18	HC150044	Relay - Miniature DPDT 230V Au Contact
19	HC150343-01	Relay - Control Flange DPDT 12VDC
20	HC150999	Anchor - Din Rail
21	HC151709	Knob - Rotary Disconnect
22	HC150033	Membrane - Cab
23	HC151698	Board - PC Main WIFI

**Use only original or authorized replacement parts with this freezer.  
Use of unapproved parts will void warranty.**



## Figure 10 Panel Breakdown (Parts)

Item	Part No.	Description
1	HC136289	Panel - Side Lh
2	HC121303	Panel - Assy Top (Air Cooled)
3	HC121140	Panel - Assy Top (Water Cooled)
4	HC135254	Channel - Rear Lh
5	HC136313	Panel - Rear
6	HC130021	Channel - Rear Rh
7	HC136216	Panel Side Rh
8	HC121294	Panel Assy - Front
9	HC115132	Insert - Drip Tray
10	HC196108-01	Tray - Drip 26 Inch White
11	HC114262	Shell - Assy Door 26 In
12	HC141353	Trimstrip - Lower 26In
13	HC121375	Trimstrip - Assy W/Dq Decal
14	HC141323	Cover - Electric Box
15	HC140128-01	Panel - Dispense

Panel Decals & Labels	
Part No.	Description
HC165119	6" Air Flow
HC165025	Beater Warning
HC164031	Blade Installation
HC164452	Cleaning Instructions
HC165093	Clear Overlay
HC165013	CMT Patent
HC165002	General Purpose Receipt
HC164110	MTS Connect Red Line
HC164127	Operating Instructions
HC165126	Panel Removal
HC165124	Top Air Discharge
HC165440-02	Trimstrip IDQ 26"
HC164477-01	Trimstrip LH
HC164021-01	Trimstrip RH
HC165246	Warning - Pressurized

AC = Air Cooled

WC = Water Cooled

ACR = Air Cooled Remote

LH = Left hand side of freezer when facing front.

RH = Right hand side of freezer when facing front.

**Use only original or authorized replacement parts with this freezer.  
Use of unapproved parts will void warranty.**

**Figure 11 Air Cooled Side/Back View (Breakdown)**

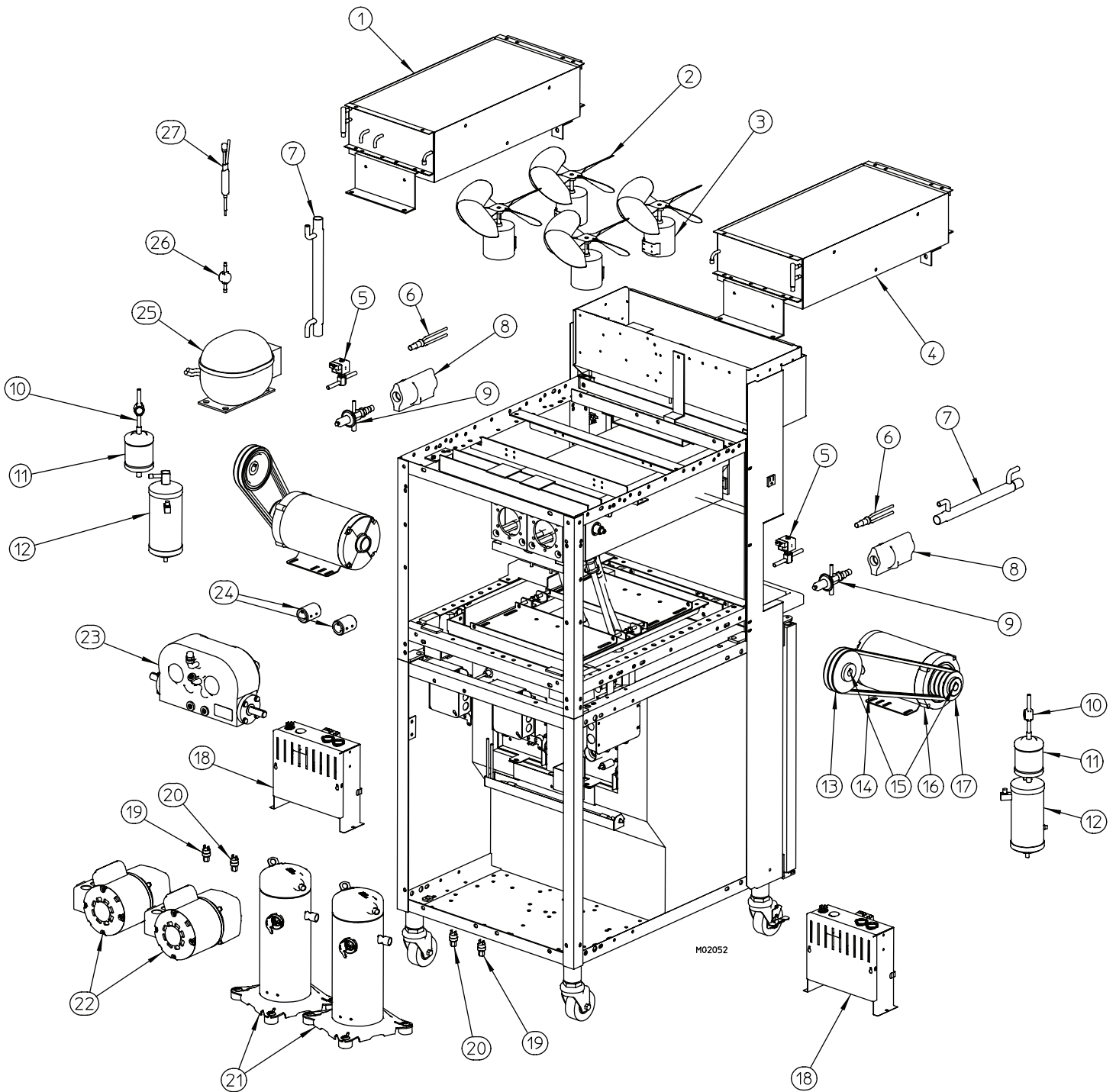

**Use only original or authorized replacement parts with this freezer.  
Use of unapproved parts will void warranty.**

## Figure 11 Air Cooled Side/Back View (Parts)

Item	Part No.	Description
1	HC155102	Condenser - Air Rifled
2	HC159023	Blade - Fan 11 In 36 Deg
3	HC151077-01	Motor - Fan 50W 230V 50/60Hz
4	HC155101	Condenser - Air Rifled
5	HC155395	Valve - Solenoid Body 3/8 Odm
5A	HC151477	Coil - Solenoid 208-240V Mkc-1Ts
6	HC155494	Distributor - Refrigerant
7	HC155495	Heat Exchanger
8	HC165531	Insulator - Expansion Valve
9	HC155493	Valve - Automatic Expansion
10	HC155059	Glass - Sight
11	HC155054	Drier - Filter 16 Cu In
12	HC155071	Receiver - 3Lb 3/8 Id Sweat W/O Valve
13	HC153625	Sheave - 3/4 Bore 4.75 Od 4.50Pd
14	HC153171	Belt-V LH
14A	HC153161	Belt-V RH
15	HC153322	Key - Drive 3/16 Sq X 1 1/2
16	HC151052-01	MOTOR - 2HP 208/230/460-3-60
17	HC153626	Sheave - 7/8 Bore 3.25 Od 3.00Pd
18	HC120810-04	Box - Assy Caps 2Hp Bf/2Hp Copzs
19	HC155405	Cut Out - High Pressure
20	HC155701	Cut Out - Low Pressure
21	HC154947	Compressor - Scroll Zs19kae-Pfv
22	HC121027	Gearmotor - 1/6 Hp 115/208-230/1/60 270 RPM
or	HC151161	Gearmotor - 1/8 Hp 208 - 230/3/60 270 RPM
23	HC153341	Reducer - Gear 4Cb Wintwin
24	HC111964	Coupling - Assy 1 In Drive
24A	HC153323	Key - Drive 1/4 Sq X 1 1/2
25	HC121872	Kit - Cabinet Compressor w/Relay & Cap
26	HC155459	Glass - Sight
27	HC155498	Drier - Filter W/Access

### Not Shown:

HC116410	Kit - Dispense Head Switch
HC161216	Sensor - 10K Thermistor
HC155399	Valve - Thermostatic Expansion (134a)
HC155704	Cut Out - High Pressure (134a)
HC150461	Switch - Toggle DPDT (Voltage Setting Switch)
HC151017-01	Motor - Fan 5 Watt 230V W/Plug

LH = Left hand side of freezer when facing front.

RH = Right hand side of freezer when facing front.

**Use only original or authorized replacement parts with this freezer.  
Use of unapproved parts will void warranty.**

**Figure 12 Water Cooled Side/Back View (Breakdown)**

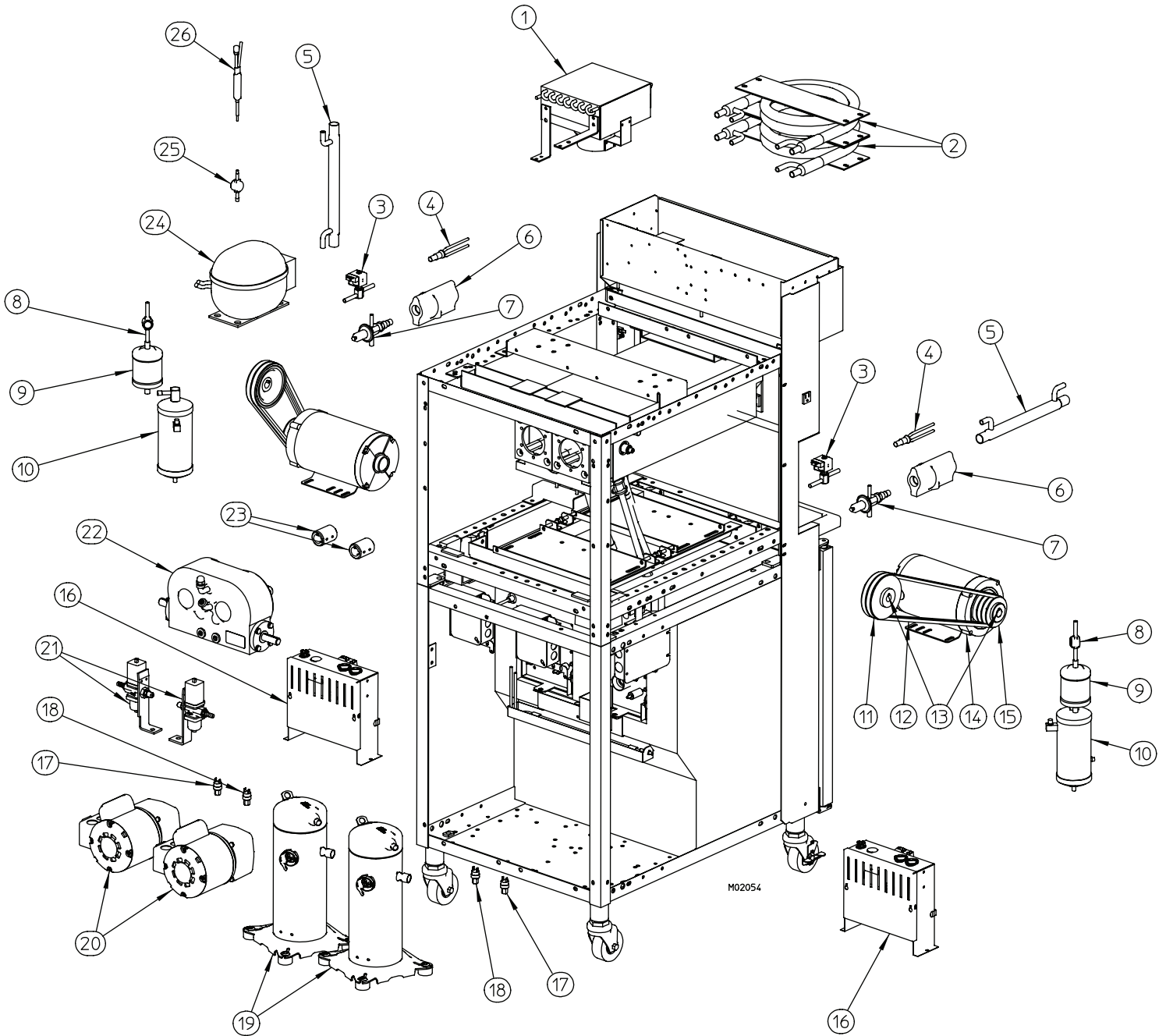

**Use only original or authorized replacement parts with this freezer.  
Use of unapproved parts will void warranty.**

## Figure 12 Water Cooled Side/Back View (Parts)

Item	Part No.	Description
1	HC120189-01	Condenser - Assy Cab Comp
2	HC155029	Condenser - Water
3	HC155395	Valve - Solenoid Body 3/8 Odm
3A	HC151477	Coil - Solenoid 208-240V Mkc-1Ts
4	HC155494	Distributor - Refrigerant
5	HC155495	Heat Exchanger
6	HC165531	Insulator - Expansion Valve
7	HC155493	Valve - Automatic Expansion
8	HC155059	Glass - Sight
9	HC155054	Drier - Filter 16 Cu In
10	HC155071	Receiver - 3Lb 3/8 Id Sweat W/O Valve
11	HC153625	Sheave - 3/4 Bore 4.75 Od 4.50Pd
12	HC153161	Belt-V RH
12A	HC153171	Belt-V LH
13	HC153322	Key - Drive 3/16 Sq X 1 1/2
14	HC151052-01	MOTOR - 2HP 208/230/460-3-60
15	HC153626	Sheave - 7/8 Bore 3.25 Od 3.00Pd
16	HC120810-04	Box - Assy Caps 2Hp Bf/2Hp Copzs
17	HC155405	Cut Out - High Pressure
18	HC155701	Cut Out - Low Pressure
19	HC154947	Compressor - Scroll Zs19kae-Pfv
20	HC121027	Gearmotor - 1/6 Hp 115/208-230/1/60 270 RPM
or	HC151161	Gearmotor - 1/8 Hp 208 - 230/3/60 270 RPM
21	HC112080	Valve - Assy Water
22	HC153341	Reducer - Gear 4Cb Wintwin
23	HC111964	Coupling - Assy 1 In Drive
23A	HC153323	Key - Drive 1/4 Sq X 1 1/2
24	HC121872	Kit - Cabinet Compressor w/Relay & Cap
25	HC155459	Glass - Sight
26	HC155498	Drier - Filter W/Access

### Not Shown:

HC116410	Kit - Dispense Head Switch
HC161222	Sensor - 10K Thermistor
HC155399	Valve - Thermostatic Expansion (134a)
HC155704	Cut Out - High Pressure (134a)
HC150461	Switch - Toggle DPDT (Voltage Setting Switch)
HC151017-01	Motor - Fan 5 Watt 230V W/Plug
HC121441	Transducer (to pressure switch) Replacement Kit

LH = Left hand side of freezer when facing front.

RH = Right hand side of freezer when facing front.

**Use only original or authorized replacement parts with this freezer.  
Use of unapproved parts will void warranty.**

**Figure 13 Gear Reducer**

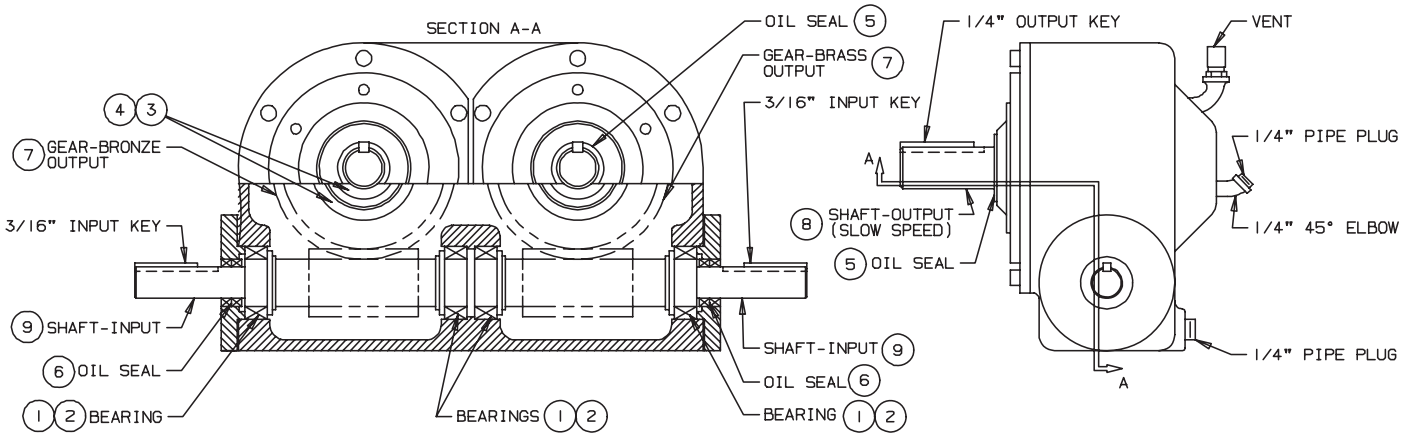

M00057

(Order by freezer serial number)

Model — Wintwin

HC153341 Wintwin 10 - 1 Ratio A and B Side

Item	Part No.	Description	Required Per Side
1	HC153014	Bearing - High Speed Cup	2 ea.
2	HC153015	Bearing - High Speed Cone	2 ea.
3	HC153011	Bearing - Slow Speed Cup	2 ea.
4	HC153012	Bearing - Slow Speed Cone	2 ea.
5	HC153051	Seal - Oil (Slow Speed)	2 ea.
6	HC153053	Seal - Oil (High Speed)	2 ea.
7	HC153349	Gear - Bronze	1 ea.
8	HC153350	Shaft - Slow Speed	1 ea.
	HC153000	Gear - Assy. Output (Slow Speed)	
9	HC153348	Shaft - Input (High Speed)	1 ea.

**Not Shown:**

- HC114874 ..... Kit - Reducer Gasket 4CB ..... 1 ea.
- HC111964..... Coupling - Assy. 1 inch Drive
- HC153322 ..... Key - Drive 3/16" High (in)
- HC153323 ..... Key - Drive 1/4" Slow (out)

**\*\*Oil-Gear Reducer (per quart)**

**\*\*Note:** To order oil always verify type of oil from the tag located on the gear reducer. Improper oil usage will cause the gear reducer to fail.

**Use only original or authorized replacement parts with this freezer.  
Use of unapproved parts will void warranty.**

**Figure 14 Evaporator Mix Tube Assembly**

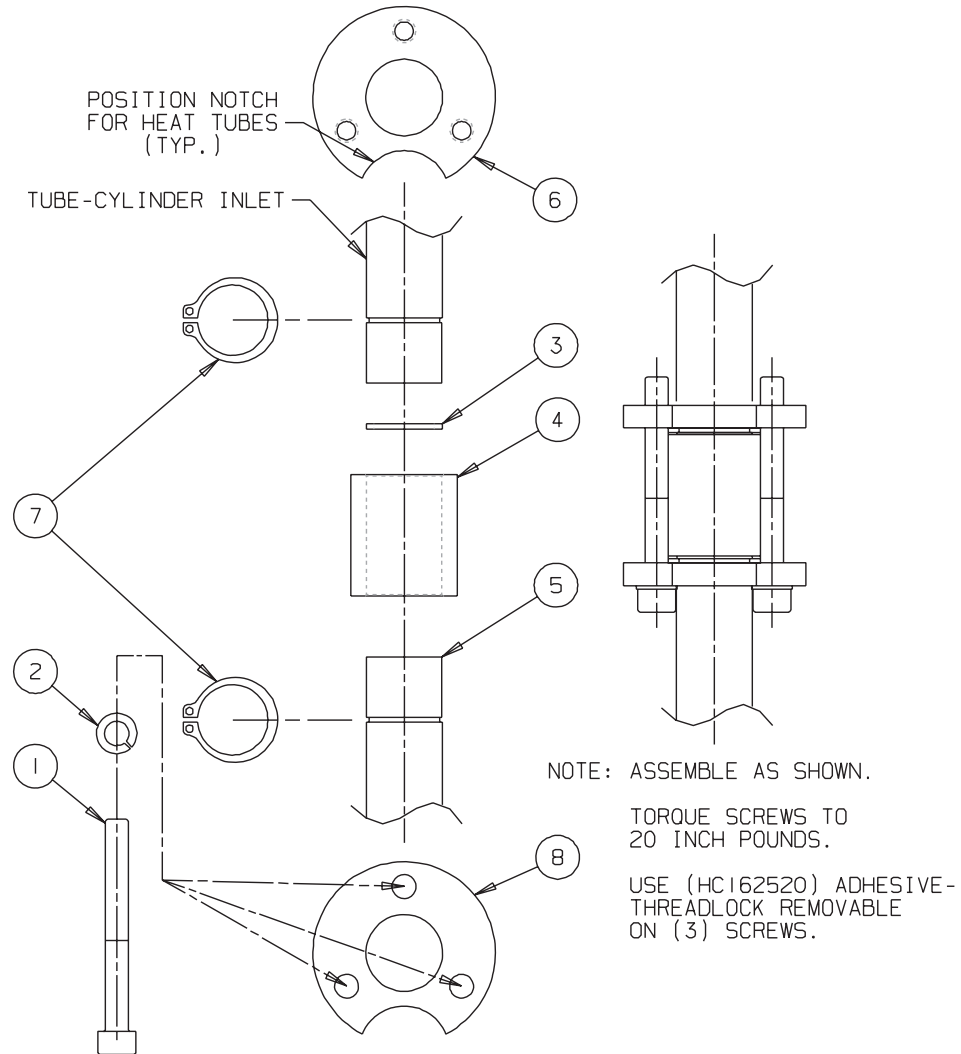

Item	Part No.	Description
1	HC160320	Screw - SKHC #10-24 x 1-3/4 SST
2	HC160166	Washer - Lock #10 ST
3	HC160556	Gasket - Mix Joint
4	HC139351	Collar - Alignment
5	HC139349	Tube - Mix Feed Clamp
6	HC139352	Clamp - Ring Threaded
7	HC160312	Ring - Retaining 5/8 Ext. SST
8	HC139353	Clamp - Ring

**Use only original or authorized replacement parts with this freezer.  
Use of unapproved parts will void warranty.**

**Figure 15 Air Cooled Remote Condenser**

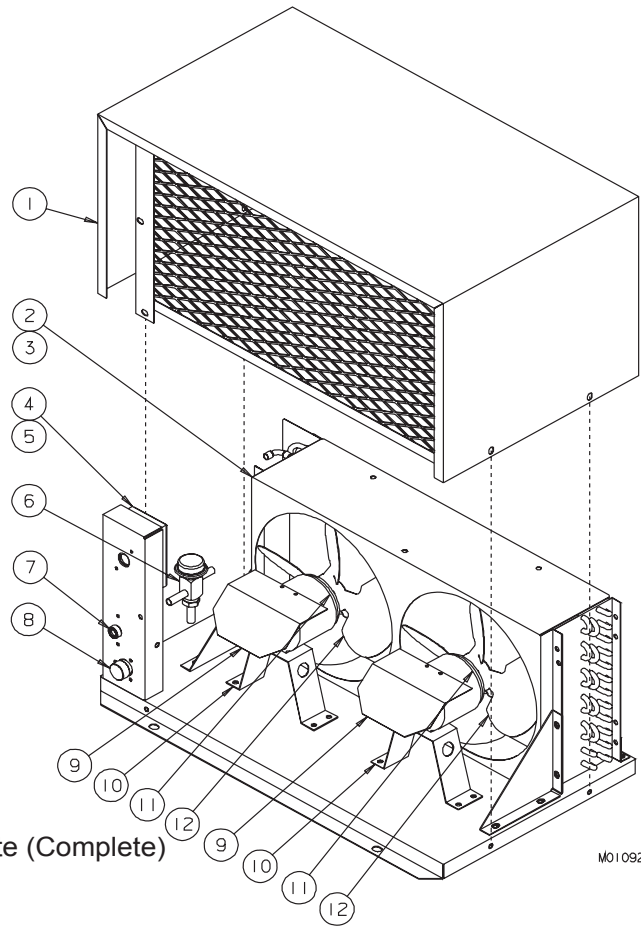

M01092

Item	Part No.	Description
*	HC116781-03	Condenser - Assy. 2 Hp Remote (Complete)
1	HC117207	Cover - Assy. Condenser
2	HC155101	Condenser - Air Rifled
3	HC138465	Shroud - Fan
4	HC150732	Box - Electric 2-3/4 x 4-1/2 x 2
5	HC150737	Cover - Electric Box 2-3/4 x 4-1/2
6	HC155454-01	Valve - Head Pressure Control 210 PSIG
7	HC153420	Coupling - Refr. 3/8 MQC 3/8 SW
7A	HC191538	Plate - Coupling Mtg.
8	HC153418	Coupling - Refr. 1/2 MQC 1/2 SW
8A	HC153502	Flange - Refr. Coupling Mount
8B	HC153503	Cap - Dust Refr. Coupling
9	HC139017	Shield - Motor Rain
10	HC137632	Bracket - Fan Condenser
11	HC151072	Motor - Fan 50W 230V 60Hz
12	HC159029	Blade - Fan 11" Dia 36°

\* Includes items 2-12 above

**Not Shown:**

- HC155058 Receiver - 12 lb. Horizontal Mount
- HC155450 Cut Out - High Pressure 450 PSI
- HC155705 Cut Out - Low Pressure 2IN HG
- HC155466 Control - Pressure Fan
- HC155487 Valve - Check 5/8 ODF Sweat
- HC119124 Kit - 25 Foot Line Sets 404a
- HC119125 Kit - 50 Foot Line Sets 404a

**Use only original or authorized replacement parts with this freezer.  
Use of unapproved parts will void warranty.**

## Accessories

Part No.	Description
HC137870 .....	Adapter - Star/Spigot
HC196103 .....	Bottle - Wash
HC158009 .....	Brush - 4" Cylinder w/o Handle
HC158018 .....	Brush - 7/16" Dia 12" Overall Length
HC158019 .....	Brush - 9/16" Dia 30" Overall Length
HC158026 .....	Brush - 1" Dia. 12" Long
HC158037 .....	Brush - 1/4" Dia. x 18-1/2" Overall Length
HC162105 .....	Caster - 1-1/4" ST PT With Brake
HC162106 .....	Caster - 1-1/4" ST PT Without Brake
HC184238 .....	Chart - O-Ring Laminated
HC158051 .....	Cup - Overrun-One Pint
HC184644 .....	DVD - Training 919RMT, 929RMT, 959RMT
HC158012 .....	Handle - Brush Fiberglass
HC136567 .....	Hose - Spigot Drain
HC112978 .....	Leg - Assy. 6"
HC158054A.....	Lubricant - Lubri Film Plus 4 oz. tube
HC158066 .....	Lubricant - Compound Seven 4 oz. tube
HC196192 .....	Nozzle - Serrated Six Point (Star)
HC158014 .....	Sanitizer - Stera Sheen Case 4-4lb.jars
HC158014A.....	Sanitizer - Stera Sheen 4 lb. jar
HC158049 .....	Scale - Overrun
HC158043 .....	Rod - Stir
HC169374 .....	Tool - O-Ring Removal
HC196006 .....	Tee - Plastic Hose Connection
HC196061 .....	Tubing - .600ID x .850OD PVC (Mix Line-Std.)
HC196062 .....	Tubing - .600ID x .975OD PVC (Mix Line-Hd.)

**Use only original or authorized replacement parts with this freezer.  
Use of unapproved parts will void warranty.**



# O-Ring Chart

REV. B

SOFT SERVE DISPENSING HEADS

HC184238

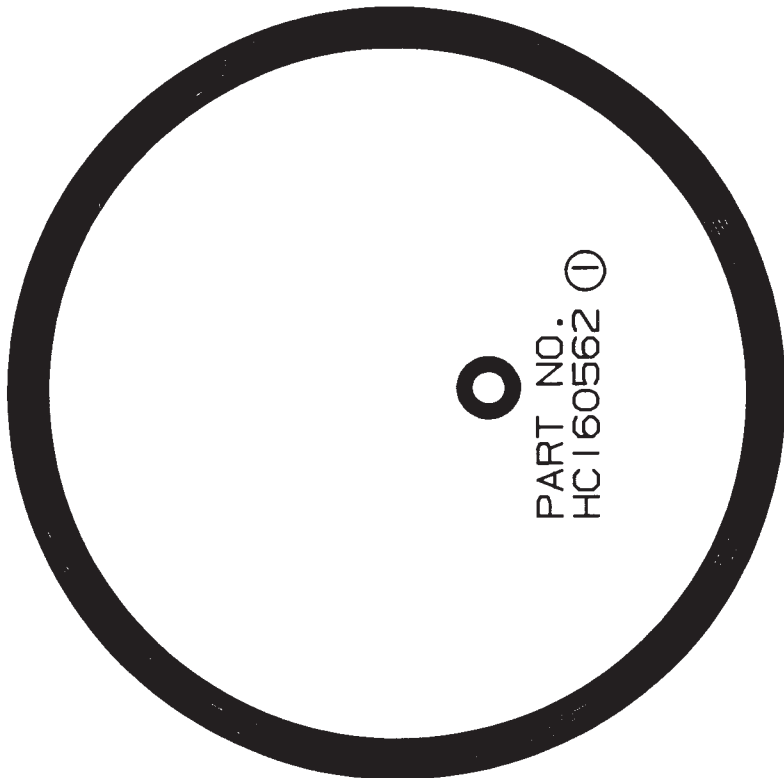
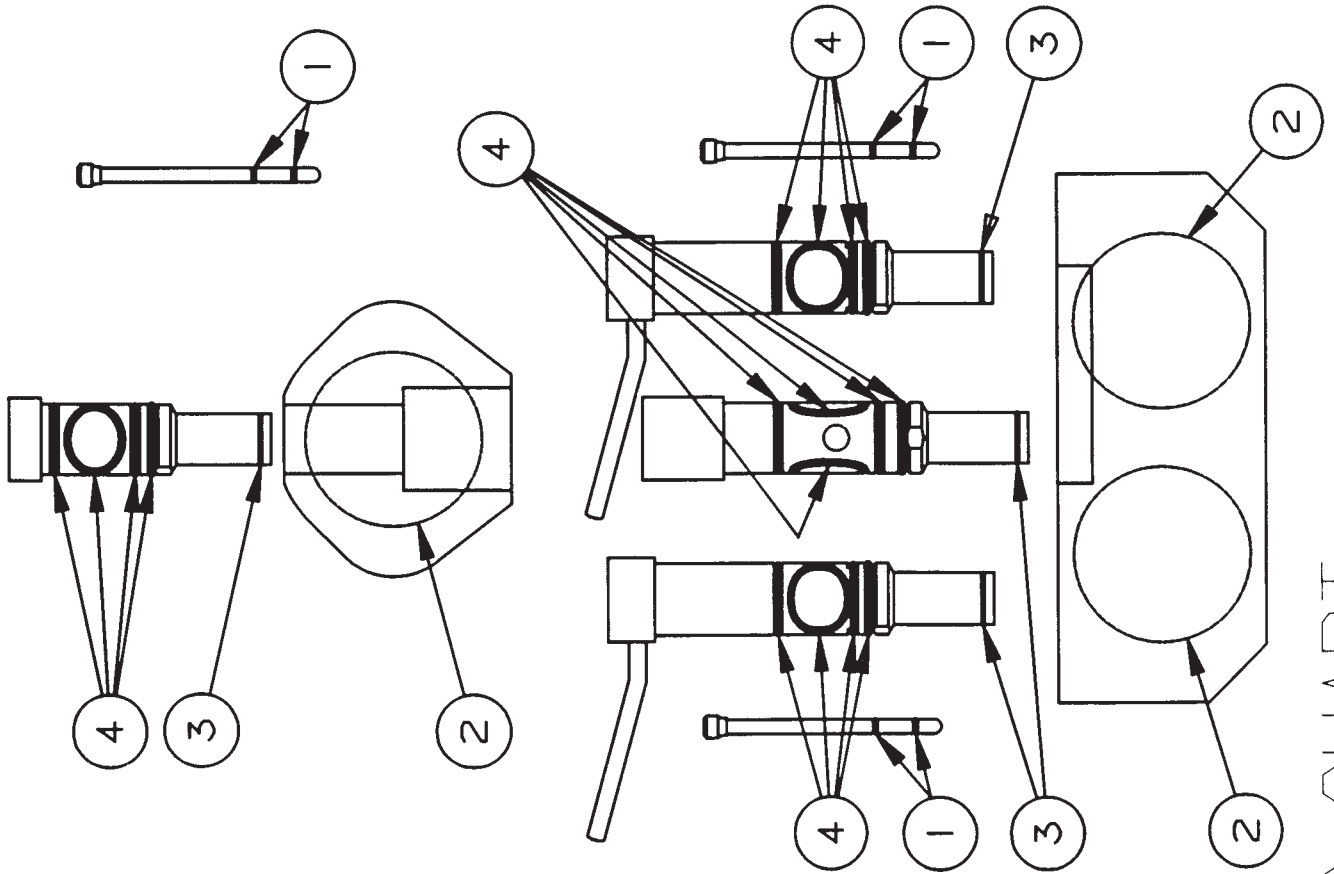

PART NO.  
HC160583 ②

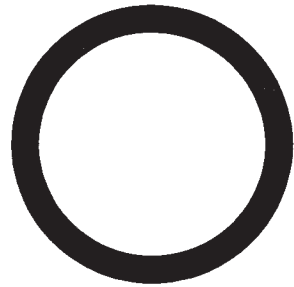

PART NO.  
HC159295 ④

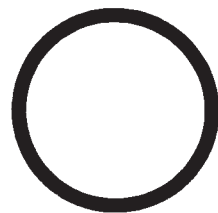

PART NO.  
HC160584 ③

O-RING CHART

H.C. DUKE & SON, INC.

PH. NO. 309-755-4553

