



Operator's Manual

with Replacement Parts List

**SOFT SERVE
TWIST MODEL
SLX400, SLX400E,
SLX500**

184584 6/14/13

**Operator's Manual
for the
Electro Freeze Model
SLX400, SLX400E and
SLX500
Soft Serve Freezers**

SAFETY FIRST!

Follow these four steps to safety

1. Recognize Safety InformationLook for this safety alert symbol throughout this manual.



When you see this symbol on your freezer or in this manual, be alert to the potential for personal injury. Follow recommended precautions and safe operating practices.

2. Understand Signal Words



The signal words — **DANGER, WARNING and CAUTION** — are used with the safety alert symbol (DANGER decals on the freezer may or may not have the safety alert symbol, but the message is the same). Decals with the words **DANGER, WARNING or CAUTION** appear on the freezer. **DANGER** identifies the most serious hazard. Decals with the words **DANGER or WARNING** are typically near specific hazards on the freezer. General precautions are listed on **CAUTION** safety decals.

In this manual, **CAUTION** messages with the safety alert symbol  call attention to safety messages.

SAFETY FIRST!

3. Follow Safety Instructions

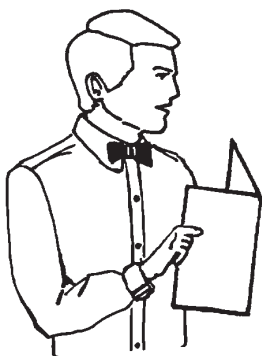

Read and understand all safety messages in this manual. Read and understand the decal safety messages on your freezer. Take notice of the location of all decals on the freezer and keep the safety decals in good condition. Check them periodically and replace missing, damaged or illegible safety decals. The safety decals must remain in place and legible for the life of the freezer. If you need new decals, use the information and illustrations on pages iv and v of this manual to identify the decal and contact your local distributor — or H.C. Duke & Son, LLC.

DO NOT attempt to operate the freezer until you read and understand all safety messages and the operating instructions in this manual.

4. Operate Safely



DO NOT allow untrained personnel to maintain or service this machine. Failure to follow this instruction may result in severe personal injury. ***DO NOT*** operate the freezer unless all service panels and access doors are secured with screws. ***DO NOT*** attempt to maintain or repair the freezer until the main power supply has been disconnected. Some freezers have more than one disconnect switch. Contact your local Electro Freeze Distributor for authorized service.

Safety Decal Locations

Do not attempt to operate the freezer until all safety precautions and operating instructions in this manual are read and understood.

Take notice of all warning, caution, instruction and information decals (or labels) on the freezer as shown in the figure to the right. The labels have been put there to help maintain a safe working environment.

The labels have been designed to withstand washing and cleaning. All labels must remain legible for the life of the freezer. Check labels periodically to be sure they can be recognized as warning labels.

If it is necessary to replace *any* label, please contact your local authorized Electro Freeze Distributor or H. C. Duke & Son, LLC. When ready to order you will need to determine the (1) part number, (2) type of label, (3) location of label, and (4) quantity required, and include a return shipping address.

You may contact your local authorized Electro Freeze Distributor, as follows:

NAME: _____

ADDRESS: _____

PHONE: _____

or — for factory service assistance — contact H. C. Duke & Son, LLC, Electro Freeze Service Department by phone or FAX:



Phone: (309) 755-4553
(800) 755-4545

FAX: (309) 755-9858

E-mail: service@electrofreeze.com

(The decals on the next page are numbered 1 and 2. Those numbers correspond to the numbers in the table below. The table provides the part number, description, and quantity for each decal.)

No.	Part No.	Description (Qty)
1	HC165025-03	Decal — Beater Warning Black(1)
2	HC165025-04	Decal — Beater Warning Twist (1)
3	HC165126	Decal — Panel Removal Warning (3)

Safety Decal Locations (continued)

⚠ WARNING

Hazardous rotating beater shaft. Do not operate unit with dispense head removed.

Before removing dispense head:

1. Turn all control switches to "OFF", and
2. Disconnect all power supplies. Unit may have more than one power supply.

1 HC165025-03

⚠ WARNING

- Hazardous rotating beater shaft. Do not operate unit with dispense head removed.
- Before cleaning machine:
 1. Turn all control switches to "OFF", and
 2. Disconnect all power supplies. Unit may have more than one power supply.



HC165025-01

2 HC165025-04
Located behind the head

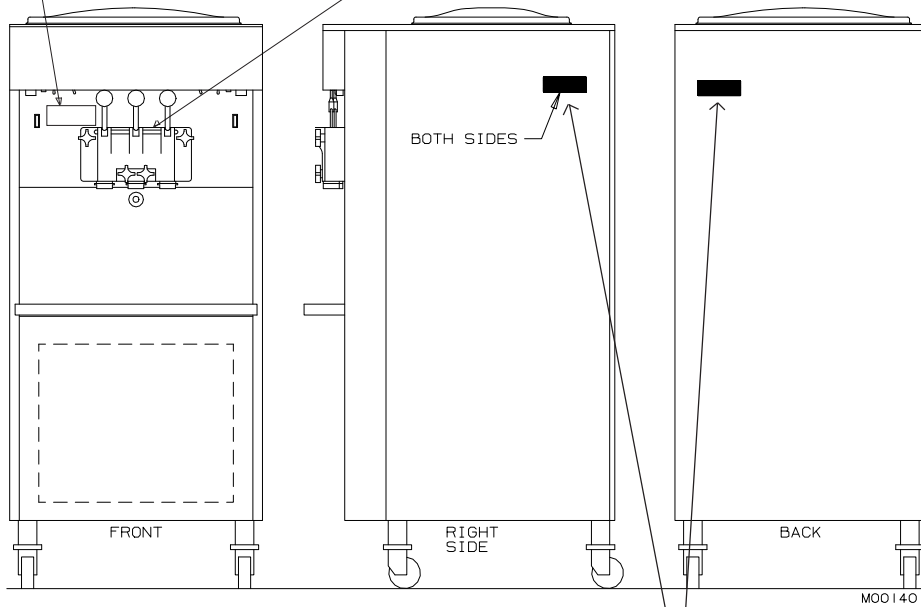

2



⚠ WARNING

Hazardous moving parts.
Machine starts automatically.
Do not operate with panel removed.

P/N 165126

Table of Contents

Safety First! ii
Safety Decal Locations iv

PART I

1 Introduction 1

2 Note to Installer 1
 2.1 Uncrating and Inspection 2
 2.2 Installation 3
 2.3 Electrical Requirements - Models SLX500 and SLX400 3
 2.4 Electrical Requirements - Model SLX400E 4
 2.5 Electrical Connections 4

3 Specifications 5
 3.1 Particulars 5
 3.2 Data Plate 6
 3.3 Reference Information 6
 3.4 Installation Date 7
 3.5 Dimensions 7

4 Virtual Quality Management System (VQM) Terminology 8

5 Part Names and Functions 10

6 Operator Controls & Indicators 13
 6.1 Freezer Symbol 14
 6.2 Left Side Controls 14
 6.3 Indicates Mode of Operation 14
 6.4 OFF Indicator 14
 6.5 Functions buttons (Four) 14
 6.6 Information Window 14
 6.7 Wash or Clean Mode 14
 6.8 Night Mode Button 15
 6.9 Freeze Mode Button 15
 6.10 OFF Button 15
 6.11 Left Side Beater "ON" Button 15

Table of Contents (continued)

6	Operator Controls & Indicators (continued)	
	6.12 Left Side Beater "OFF" Button	15
	6.13 Arrow Buttons	15
	6.14 Power Switch	16
	6.12 Mix Feed Tube & Regulator	16
7	Operator Display Hidden Menu	17
8	Disassembly and Cleaning	20
	8.1 Cleaning Accessories	20
	8.2 Disassembly Instructions	21
	8.3 Cleaning Instructions	23
9	Assembly	25
10	Start-up Instructions	28
	10.1 Sanitizing	28
	10.2 Priming	30
	10.2.1 Standard Priming Instructions	30
	10.2.2 Priming Instructions	31
11	Closing Procedures	32
	11.1 Night Switch Operation	32
	11.2 Draining Product	33
12	Soft Serve Information	34
	12.1 Overrun	34
	12.2 Rerun	34
13	Routine Maintenance	35
14	Troubleshooting Tables	39

PART II

REPLACEMENT PARTS with ILLUSTRATIONS *

* Refer to Part II Table of Contents for help with locating part numbers and illustrations.

1 Introduction

Gravity fed soft serve freezer models SLX400, SLX400E, and SLX500 are designed to produce soft serve ice cream, ice milk, yogurt, and similar frozen dairy products, with a product serving temperature range of 15 to 25°F (-9 to -4°C). If such products are prepared from powdered concentrate, they should be precooled to 40°F (4°C) prior to introduction to the freezer. Use of other products in this machine is considered misuse (see Warranty).

This manual has been prepared to assist you in the proper operation and general maintenance of the *Electro Freeze* model SLX400, SLX400E, and SLX500 freezers.

Make sure all personnel responsible for equipment operation completely read and understand this manual before operating the freezer. When properly operated and maintained, the freezer will produce a consistent quality product.

If you require technical assistance, please contact your local authorized *Electro Freeze* Distributor, as follows:

Name: _____

Address: _____

Phone: _____

For factory service assistance — contact H. C. Duke & Son, LLC, *Electro Freeze* Service Department as follows.



Phone: (309) 755-4553
(800) 755-4545

FAX: (309) 755-9858

E-mail: service@electrofreeze.com

2 Note to Installer

This freezer must be installed and serviced by an *Electro Freeze* Distributor or authorized service technician in accordance with the installation instructions.

After installation the warranty registration card must be completed and returned to validate the warranty.

2.1 Uncrating and Inspection

CAUTION

Be sure to properly support the machine when removing bolts and installing legs or casters.

When the unit is received and while the carrier is still present, inspect the shipping carton for any damage that may have occurred in transit. If the SHOCKWATCH® label indicates red and/or the carton is broken, torn, or

punctured, note the damage on the carrier's freight bill and notify the carrier's local agent immediately.

1. Remove the carton from the pallet, and move the machine as close as possible to the permanent location.

2. Remove the shipping bolts on the bottom of the freezer (figure 2-1) and install either the legs or casters (figure 2-2).

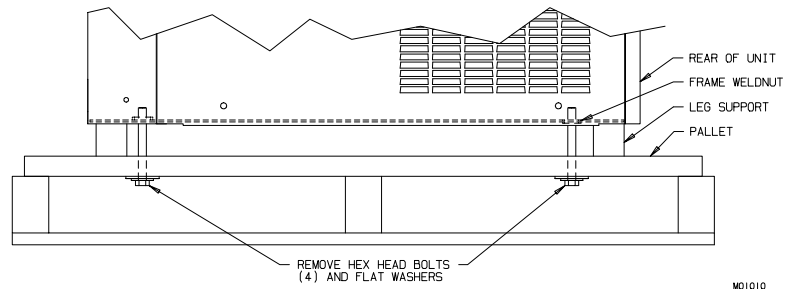
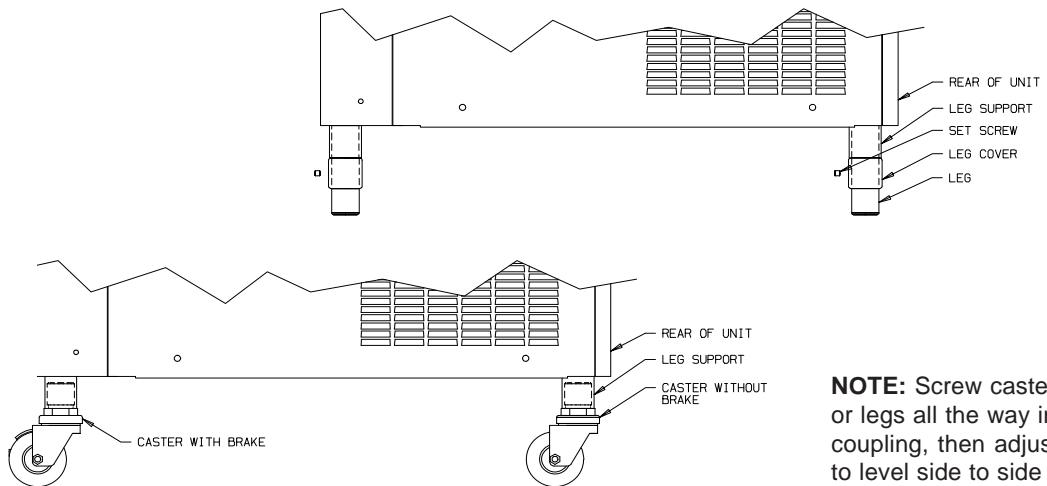

Figure 2-1 Machine bolted to Shipping Base



NOTE: Screw casters or legs all the way in coupling, then adjust to level side to side with a 1/4" slope to the front.

Figure 2-2 Installing Mounting Legs or Casters

2.2 Installation



CAUTION
All materials and connections must conform to local requirements and be in compliance with the National Electrical Code (NEC).

1. The freezer is designed for indoor use and must be protected from outdoor weather conditions.
2. Where codes permit, Electro Freeze recommends that the floor model freezers be installed on casters and have flexible water and electrical connections for easier service and cleaning.
3. All models are required to be open at the top, have a minimum 6-inch (15.2 cm) rear clearance and 0 inches on the side panels for adequate ventilation. Anything blocking ventilation of the freezer (including cone dispensers) will reduce the efficiency of the freezer.
4. **Air cooled model SLX500** will need an air deflector if the unit is to be placed against a rear wall. The 6" wide x 21-7/8" long deflector is to be mounted to the lower rear screws on the back panel of the freezer. **Failure to install the deflector will void warranty.**
5. **Water-cooled** models require a 3/8-inch MPT water inlet and water waste connection. The connections are found on the bottom, under the compressor mounting area. They are tagged "Water Inlet" and "Water Waste." A manual shut-off valve should be installed in the water inlet line at the time of installation. The water pressure must be between 35-140 psig (241-965 kPa) for proper operation.
6. Place the freezer in its final location and adjust the legs or casters so that it is level side-to-side and the front is approximately 1/4-inch lower than the rear to allow proper drainage of the freezing cylinder.

2.3 Electrical Requirements-Models SLX500 and SLX400



CAUTION
To prevent accidental electrical shock, a positive earth ground is required.

1. Always verify electrical specifications on the data plate (figure 3-1) of each freezer. Data plate specifications will always supersede the information in this manual.
2. Supply voltage must be within \pm 10% of voltage indicated on the nameplate. Also, on three-phase systems, voltage between phases must be balanced within 2%. (More than a 6 volt difference between any two voltage measurements at 208-230 volts indicates a possible imbalance.) Request your local power company to correct any voltage problem.
3. An easily accessible main power disconnect must be provided for all poles of the wiring to the freezer.

2.4 Electrical Requirements - Model SLX400E ONLY



CAUTION
To prevent accidental electrical shock, a receptacle with a positive earth ground is required.

1. Always verify electrical specifications on the data plate (figure 4-1) of each individual freezer. Data plate specifications will always supersede the information in this manual.
2. This freezer requires a protected 20 amp 220 volt circuit. Connect the freezer to a circuit separate from any other electrical equipment. The freezer plug will fit a NEMA 6-20R receptacle. See figure 2-3.

3. Supply voltage must be within $\pm 10\%$ of voltage indicated on the nameplate.
4. An easily accessible main power disconnect must be provided for all poles of the wiring to the freezer.

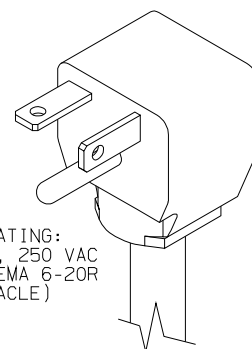

PLUG RATING:
20 AMP, 250 VAC
(FOR NEMA 6-20R
RECEPTACLE)

M01521

Figure 2-3 Plug

2.5 Electrical Connections



CAUTION
To prevent accidental electrical shock, a positive earth ground is required.

1. Freezer requires one power supply. Always check the data plate for proper fuse size, wire ampacity, and electrical specifications.
2. Refer to the wiring diagram provided for proper power connections.
3. **Electrical connections for models SLX500 and SLX400** are made in a junction box. Facing the front of the freezer it is located behind the right side panel towards the back and bottom of the frame.
4. **The Model SLX400E** is supplied with a cord and a NEMA 6-20P plug that plugs into a 6-20R receptacle. See Figure 2-3.

4. Use a flexible connection when permissible. Copper wires are required for connection to freezer. All materials and connections must conform to local codes and/or the National Electrical Code.
5. For all 3 phase freezers, beater shaft rotation must be clockwise as viewed from the front of the freezer.

3 Specifications

3.1 Particulars

Width (in/cm) 22-1/8 / 56.2

Height (in/cm) 60-11/16 / 154.15

Depth (in/cm) 30-1/8 / 76.52

	<u>SLX500</u>	<u>SLX400</u>	<u>SLX400E</u>
Weight (lb/kg)	539 / 244	500 / 226	475 / 215
Cylinder Compressor	2 HP / 10500 (BTU/hr) ... 1.9 kw (Motor) 3.2 kw (Cooling)	1.3 HP / 6900 (BTU/hr) .. 1.3 kw (Motor) 2.1 kw (Cooling)	1.3 HP / 6900 (BTU/hr) 1.3 kw (Motor) 2.1 kw (Cooling)
Hopper Compressor	1/10 HP / 500 (BTU/hr) ...	1/10 HP / 500 (BTU/hr) ...	1/10 HP / 500 (BTU/hr)
Beater Motor	(2) 2 HP/ 1.5 kw	(2) 1 HP/0.75 kw	(2) 1 HP/ 0.75 kw
Refrigerant - Cylinder	R-404a	R-404a	R-404a
Refrigerant - Hopper	R-134a	R-134a	R-134a
Charge Cylinder (lbs/kg)(A/C)	4.4 / 2.0	4 / 1.81	4 / 1.81
Charge -Cylinder (lbs/kg)(W/C)	3.75 / 1.7	3.4 / 1.54	3.4 / 1.54
Charge - Hopper (oz/kg)	7 / .2	7 / .2	7 / .2
Cooling	Air or Water	Air or Water	Air or Water
Hopper (qt/ltr)	(2) 16 / 15.1	(2) 12 / 11.4	(2) 12 / 11.4
Cylinder (qt/ltr)	(2) 3.7 / 3.5	(2) 2.7 / 2.6	(2) 2.7 / 2.6

A/C = Air Cooled

W/C = Water Cooled

3.2 Data Plate

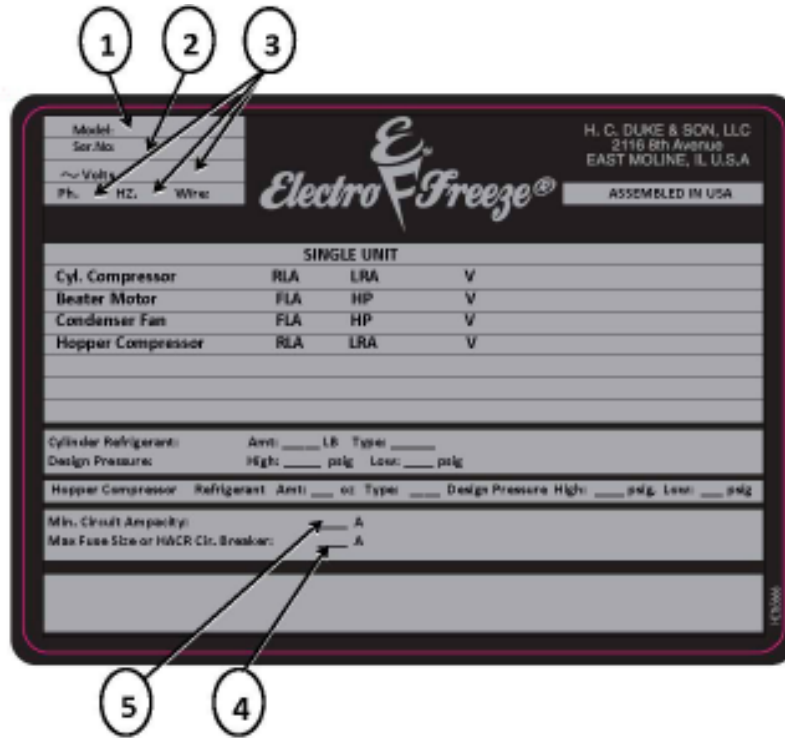

Figure 3-1

The data plate provides important information that the operator should record and have available for parts ordering, warranty inquiries and service requests.

3.3 Reference Information

Write in Reference Information HERE!



Fill in the following information as soon as you receive your *Electro Freeze* SLX400 series or SLX500 freezer. (The item numbers—encircled, below—correspond to the callout numbers in figure 3-1.)

- ① **Model Number:** _____
- ② **Serial Number:** _____
- ③ **Electrical Spec: Voltage** _____
Phase _____ Hertz _____
- ④ **Max. Fuse Size:** _____
- ⑤ **Min. Circuit Ampacity** _____

3.4 Installation Date

Fill in the date of installation, and the name, address, and phone number of the installer in the space provided below. This information will be needed when ordering parts or service for the freezer.

Date of installation: _____

Installed by: _____

Address: _____

Phone: _____

3.5 Dimensions

The dimensions of the SLX Series freezers are provided in figure 3-2 below.

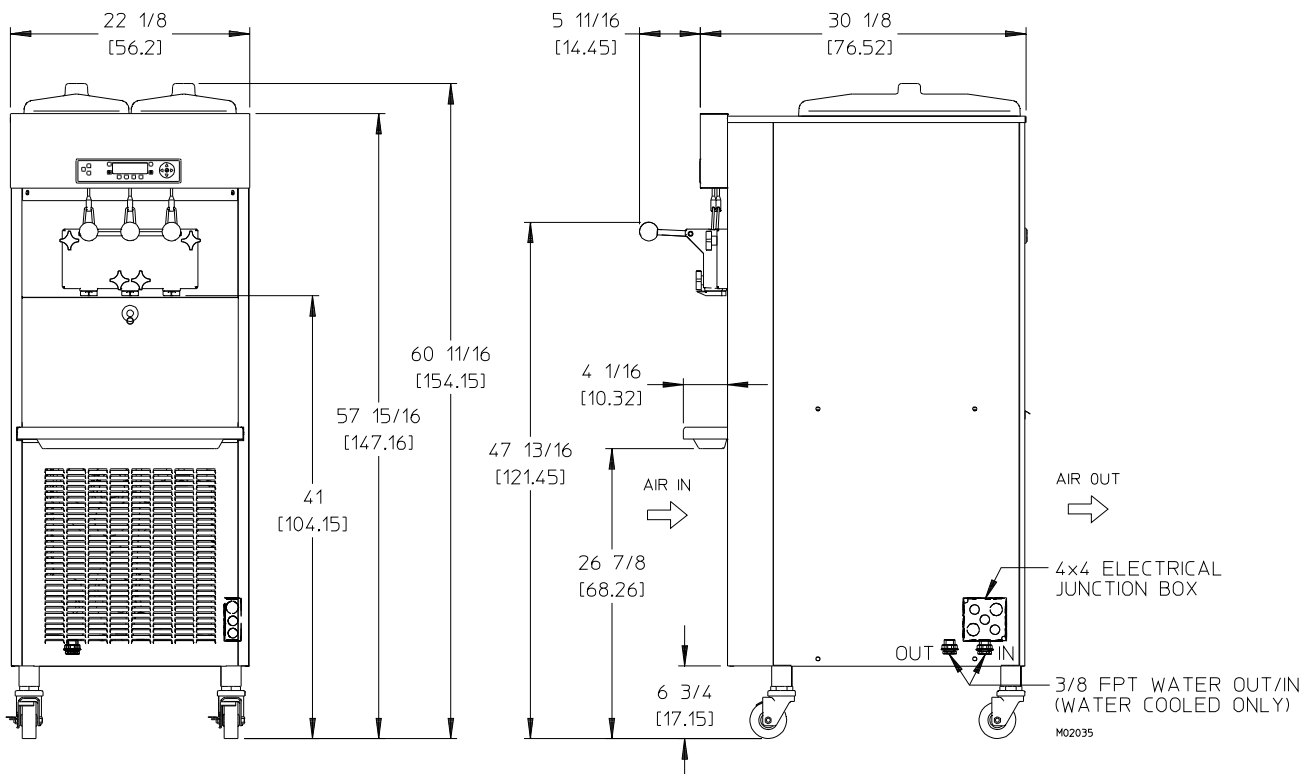

Figure 3-2 Electro Freeze SLX Series

4

Virtual Quality Management System (VQM) Terminology

- Amp Control Board: Board is located in the main contactor box responsible for monitoring the beater motor amperage and communicating that value to the main P.C. Board.
- Beater Run: This D.O.B. timer used to delay the beater motor after the refrigeration shuts down. Beater Run Range: 0 to 10 seconds
- Demand Run Comp: The D.O.B. timer used to delay the compressor when product is being drawn. Demand Run Comp. Range: 0 to 12 seconds
- Dual Hyst: The differential used when product is being drawn out of the center spigot or when both side spigots have been drawn simultaneously. Dual Hysteresis range: 7 to 20°F
- Hysteresis (Hyst): Symbolizes the differential setting. Hysteresis range: 7 to 20°F i.e. if your cut in is at 18°F and your Hysteresis is at 10°F your unit will cut out at 8°F
- Idle Run Comp: Delay on break (D.O.B.) timer used for the compressor when the unit is in idle mode/no product being drawn. Idle Run Comp. Range: 0 to 12 seconds
- Idle: When the unit is cycling on temperature and no product is being dispensed
- Lock outs: Allows the function of a specific feature/button to be temporarily disabled to deter unnecessary usage of that feature.
- Main P.C. Board: Main Control board for the unit, housed behind the trim strip panel. This board has many connectors on it and is responsible for the main operations of the unit.
- Membrane Switch: The black Electro Freeze decal visible on the front of the unit, which houses the hidden operator, technician, soft, and hard keys used to navigate the menus
- Single Hyst: The differential used when product is being drawn out of one barrel. Single Hysteresis range: 7 to 20°F
- Slope/Demand Slope: Utilizes a function within the system to watch the temperature change as the unit freezes a barrel. If utilizing the slope feature and the unit sees a lack of temperature change during freeze down, the unit will cycle off. This will prevent a freeze up condition due to a long run time. Demand Slope range: 0 to -0.2

4

Virtual Quality Management System (VQM) Terminology (continued)

- Temp. Comp.: Temperature comparison, utilized when the slope feature is turned on. It prevents the system from seeing the slope temperature curve until a determined temperature is reached. Once that temperature has been reached then the system will examine the curve and shut down if necessary.
Temp. Comp. Range: -10 to 15°F
- Temperature Offset: A function that allows temperature adjustment to the operator. Adjustable from 1-9 and 5 being neutral/no change, Lower than 5= colder and greater than 5=warmer
- U.I./ User Interface: The board that lies directly behind the membrane switch on the front panel. This board houses the LED screen that displays the menus and operations. The membrane switch is connected to this board via a ribbon cable. This board also has its own software.

5 Part Names and Functions

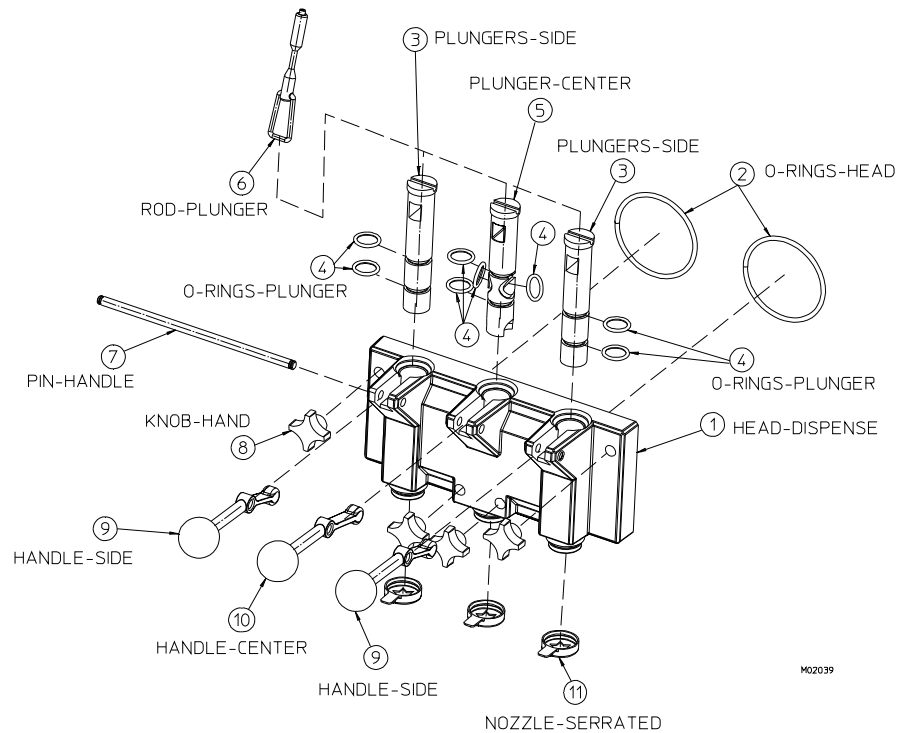

Figure 5-1 Head Assembly

The following descriptions refer to figure 5-1. The number preceding the part name corresponds to the number in the figure.

- | | |
|--|---|
| <p>① HEAD - DISPENSE
Encloses the freezing cylinder and provides an opening for product to be dispensed.</p> <p>② O-RINGS - HEAD
Seals the head to the freezing cylinder. Must be lubricated.</p> <p>③ PLUNGERS - DISPENSE - SIDE
Seals the product opening in the head when closed. Allows product to flow when open.</p> <p>④ O-RINGS - PLUNGER
Seals the plunger in the head. Must be lubricated to seal and slide freely.</p> <p>⑤ PLUNGER - DISPENSE - CENTER
Seals the product opening in the head when closed. Combines ice cream from both cylinders to form swirl cones.</p> | <p>⑥ ROD - PLUNGER
Starts the freezer when dispensing. Must be in place for proper operation.</p> <p>⑦ PIN - HANDLE
Secures handle to the head.</p> <p>⑧ KNOB - HAND
Secures the head to the freezing cylinder.</p> <p>⑨ HANDLE - DISPENSE - SIDE
Opens and closes the plunger to start and stop the flow of product from the freezer.</p> <p>⑩ HANDLE - DISPENSING - CENTER
Opens and closes the plunger to start and stop the flow of swirl product from the freezer.</p> <p>⑪ NOZZLE - SERRATED
Forms the frozen product as it is dispensed.</p> |
|--|---|

5 Part Names and Functions (continued)

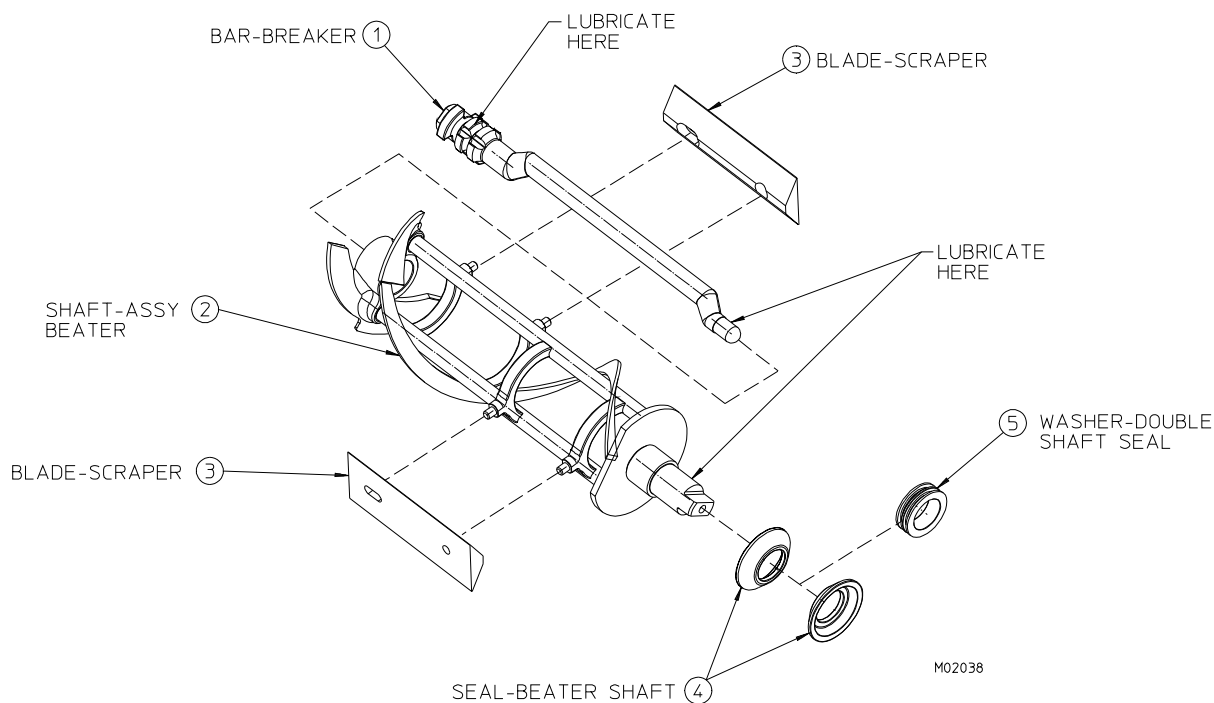

Figure 5-2 Beater Shaft Assemblies

The following descriptions refer to figure 5-2. The number preceding the part name corresponds to the number in the figure.

- | | |
|---|---|
| <p>1 BAR-BREAKER
Keeps product blended in the center of the beater shaft.</p> <p>2 SHAFT-ASSY. BEATER
Rotates in the freezing cylinder, blending air and mix. Ejects product when dispensing plunger is opened.</p> <p>3 BLADE-SCRAPER
Scrapes the frozen product from the freezing cylinder.</p> | <p>SEAL-BEATER SHAFT
Seals the opening between the freezing cylinder and the beater shaft. Consists of the following:</p> <p>4 SEAL-BEATER SHAFT</p> <p>5 WASHER-DOUBLE SHAFT SEAL</p> |
|---|---|

5 Part Names and Functions (continued)

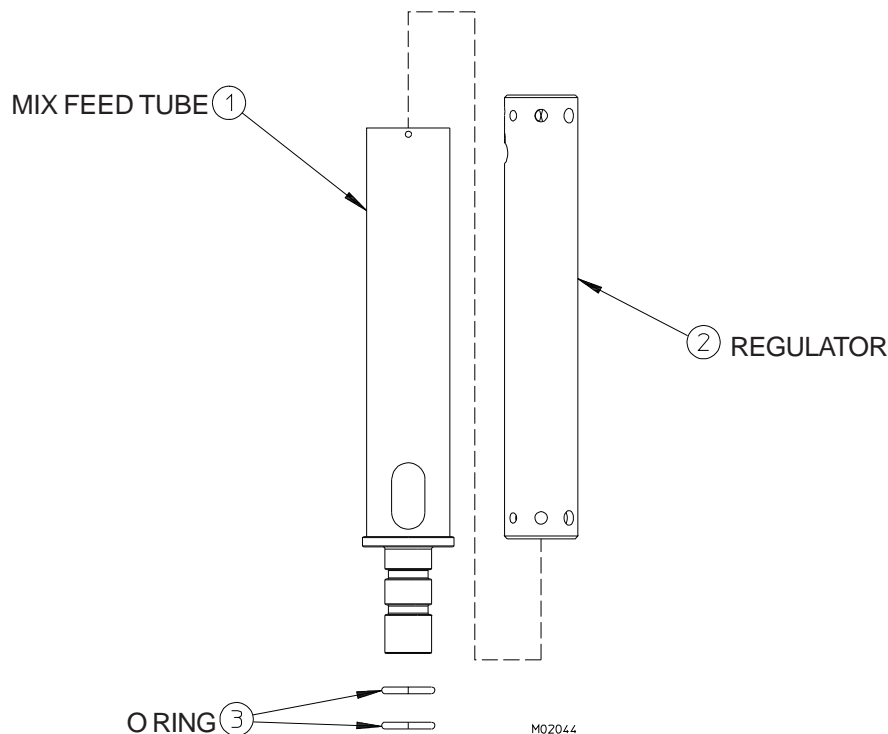

Figure 5-3 *Mix Feed Tube Assembly*

The following descriptions refer to figure 5-3. The number preceding the part name corresponds to the number in the figure.

- ① **TUBE - MIX FEED.**
Meters the correct amount of mix and air into the freezing cylinder from the hopper.
- ② **REGULATOR.**
Provides adjustment on mix feed rate and a positive shut-off of mix flow to the freezing cylinder.
- ③ **O-RING - TUBE.**
Seals the opening between the hopper and mix feed tube. (O-rings do not need lubrication.)

6 Operator Controls and Indicators

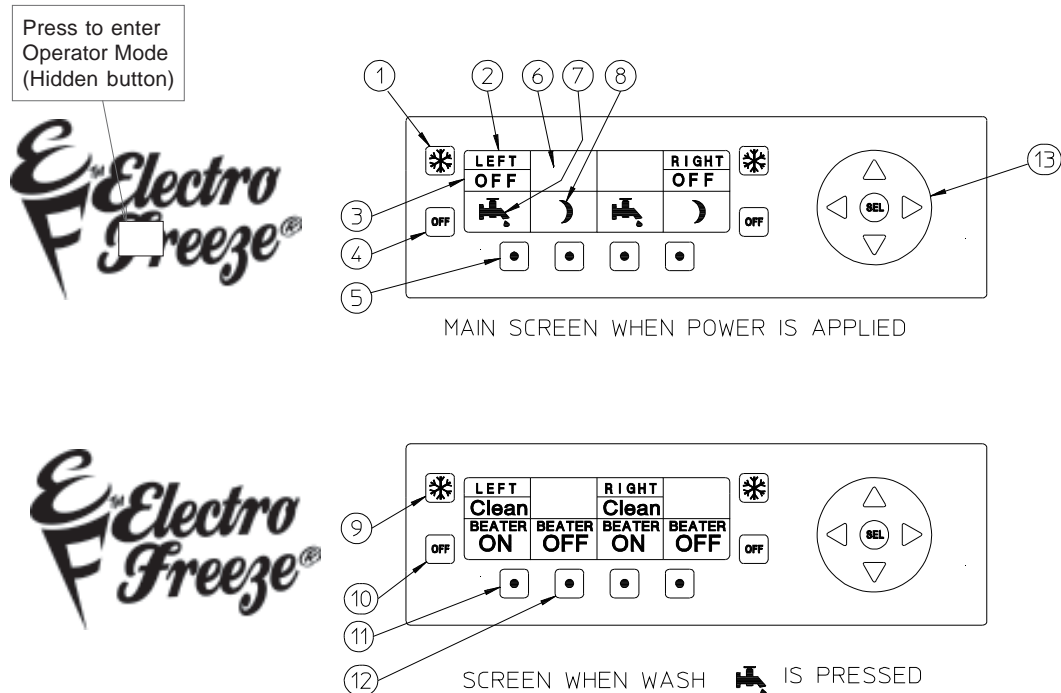

Figure 6-1

The following paragraphs describe the operator controls. Refer to Fig. 6-1 for numbered items in description. Note the left side controls operates the left side cylinder and hopper. Operation for right side controls is the same. The display window has three levels of display: Operators Menu, Technician Menu, and Factory Menu. The last two menus are restricted and reserved for use by qualified personnel.

CAUTION

Test operation of the head switch prior to placing the freezer in service. See Section 11, Routine Maintenance, Monthly.

NOTE: The dispense head must be in place before the freezer will operate.

6.1

Freeze Symbol 1

When this symbol is pressed, the unit will enter the automatic freeze mode. Both the hopper and cylinder compressors will energize to refrigerate product to settings in program. Use this button for DAY mode operation to maintain product in “ready to serve” state

6 Operator Controls (continued)

6.2 Left Side Controls ②

Indicates controls for left side cylinder and hopper. "Right" Indicates controls for right side of freezer.

6.3 Indicates Mode of Operation ③

There are three primary modes of operation:

a. OFF – This is the indicator when power is applied to freezer and when (OFF) button is pressed. In this mode, the refrigeration and beater motor will not operate.

b. FRZ – This is the indicator when Freeze button is pressed. In this mode, the freezer is in automatic freeze mode and both the beater motor and refrigeration will activate as needed. Use this position for dispensing product from freezer. Hopper will also be refrigerated as needed to maintain product below 41°F.

Important:

Do not use the  freeze position with water or sanitizer in the cylinder or hopper. The freezer will be damaged.

c. Night – This is the indicator when Night button is pressed. In this mode, an energy-saving feature will activate and reduce product refrigeration. The freezer will automatically cycle to maintain temperatures in the cylinder and hopper below 41°F and keep product from deteriorating. Use this position when the freezer will not be in use for periods of more than one hour.

6.4 OFF Indicator ④

When this symbol is pressed, the left side of unit will shut off. The beater motor and compressor will not operate.

6.5 Function Buttons (Four) ⑤

Pressing any of these buttons will activate the icon directly above in the display screen.

6.6 Information Window ⑥

This window is normally blank when unit is functioning properly. This window will give you indication when mix in hopper is low and other error messages. Refer to Troubleshooting Section of manual for details on error messages.



6.7 Wash or Clean Mode ⑦

Press the function button directly below icon to activate the wash menu screen.

6.8 Function Buttons (Four) 8

Press the function button directly below icon to activate the "Night" mode of operation.

6.9 Freeze Mode Button 9

Press  button will activate the automatic freeze mode and return display to main screen.

6.10 Off Button 10

Press OFF button to return to main screen display and turn left side of the freezer off.

6.11 Left Side Beater "ON" Button 11

Pressing this button to turn left side beater ON

6.12 Left Side Beater "OFF" Button 12

Press this button to turn left side beater OFF

6.13 Arrow Buttons 13

Used by technicians for programming an setting changes. See Troubleshooting section for Operator accessible controls.

Press to enter Operator Mode (Hidden button)

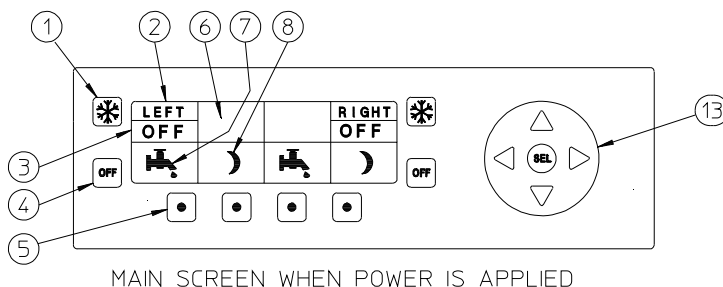

MAIN SCREEN WHEN POWER IS APPLIED

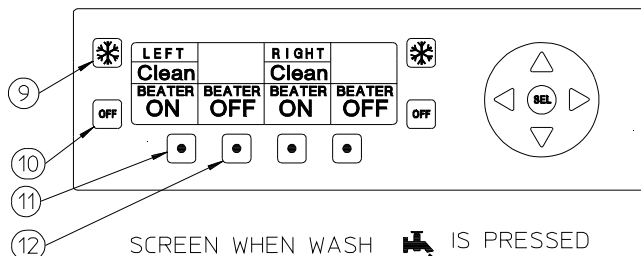

SCREEN WHEN WASH  IS PRESSED

Figure 6-1

6 Operator Controls (continued)

6.14 Power Switch 14 See Figure 6-3

In the "ON" position, power is supplied to the beater motors. Use this position to operate the freezer. Select the "OFF" position for disassembly and cleaning. See Operators Display Menu for use of this switch in recording cleaning cycles.

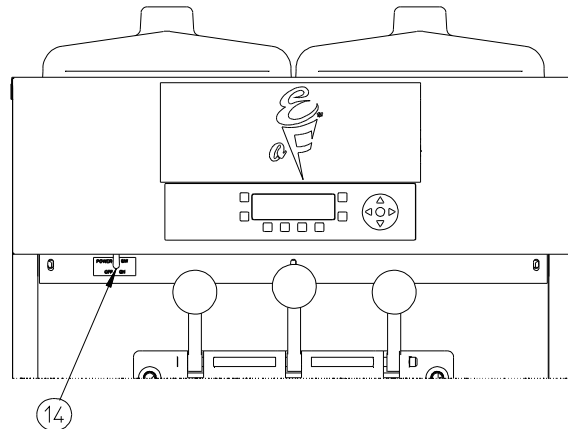

Figure 6-3

6.15 Mix Feed Tube & Regulator (not shown)

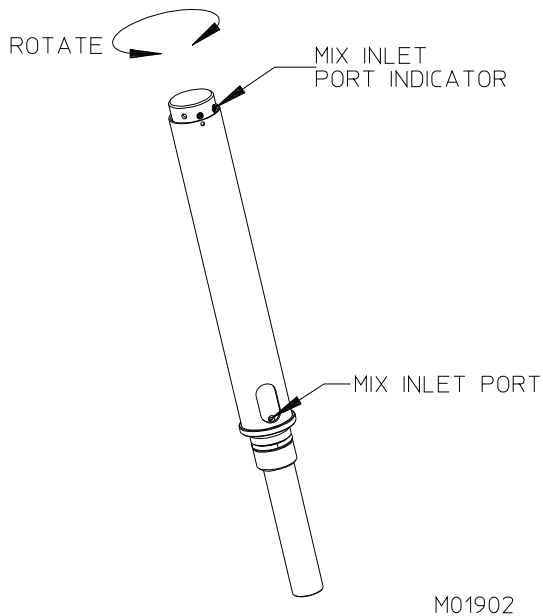

Figure 6-4

This three-position regulating device (figure 6-4) meters the correct amount of mix and air into the freezing cylinder.

1. Locate the round indent near the top of the mix tube cylinder. Align this indent to the center range of the three indent pattern on the mix feed regulator.
2. The plastic mix feed regulator may be adjusted within the three indent range to obtain an optimum product overrun and dispense speed.
3. The largest indent setting will allow the least overrun. The smallest indent setting will allow the most air in the cylinder and is used for a higher overrun.

During periods of idle or night operation, place the mix inlet port to the closed position. At this setting, mix and air flow are shut off to the cylinder.

Important:

If product is dispensed when the regulator is in the "CLOSED" position, a freeze-up will occur and may cause damage to the freezer.

7

Operator Display Menus

To Enter the Operator Menu, push and hold the hidden button under the F for 3 seconds (Figure 7-1). The operator menu will show up on the screen. The cursor will highlight the selected sub-menu (i.e. Basic Setting, Actual Temps, etc.), use the Arrow Buttons to move the cursor up or down to the desired sub-menu. Once the desired menu is highlighted, in this example we will use Basic Settings, press the select (SEL) button to enter the sub-menu. Product Type and Temperature Offset will be shown for left and right barrel. Use the Arrow Buttons to move the cursor to highlight the value to be changed, once highlighted press the select button and the cursor will now be blinking. While the cursor is blinking the value may now be changed

using the left or right Arrow Buttons, once you have reached the desired setting press select (SEL) one more time, the cursor will now stop blinking, this indicates that the value change has been stored. Follow these steps to change any other desired settings, once complete you may use the far right Function button to exit the operator menu or just wait and the menu will time out and return to the Home screen.

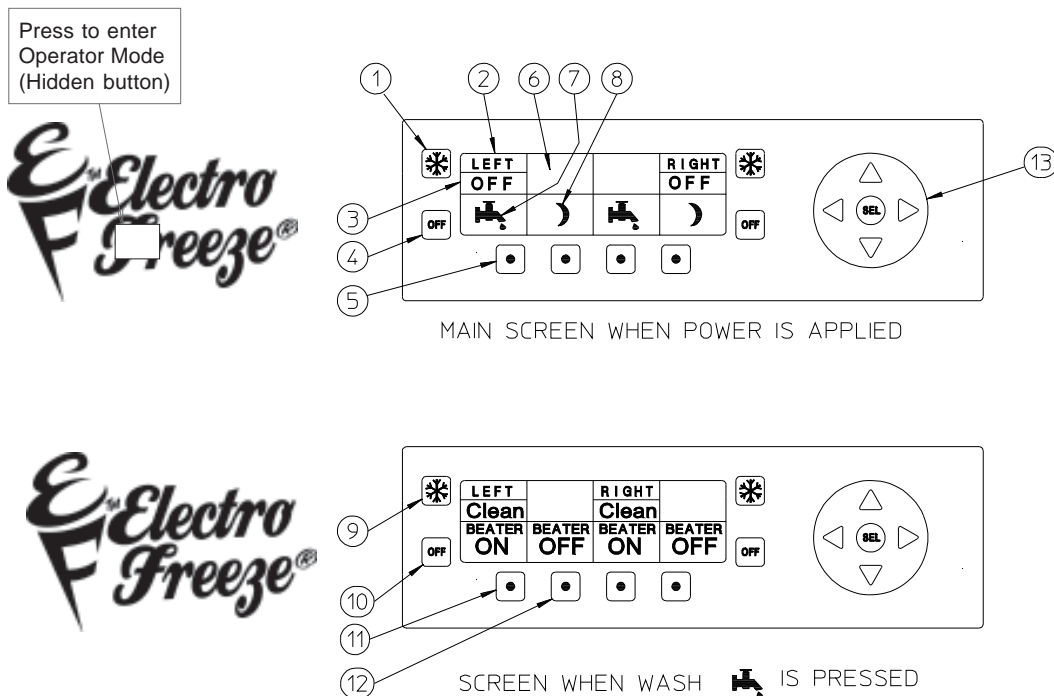

Figure 7-1

7

Operator Display Menus (continued)

Below is a list of the Operator's menu categories.

Operator's Menu Options

- Basic Settings
- Actual Temps
- Active Errors
- Lockouts
- Screen Settings
- Date/Time
- Last Clean
- Software Version
- Exit

The following information explains more about each of the menu options.

Basic Settings:	Product Type Left Barrel: nonfact, lowfat, highfat, or yogurt Right Barrel: V nonfact, lowfat, highfat, or yogurt Temperature Offset 1-9 5 is neutral
Actual Temps:	Hopper Temperature °F Left Hopper Right Hopper Barrel Temperature °F Left Barrel Right Barrel
Active Errors:	Displays active errors for the left or right systems. A blank screen means currently no errors are present.
Lockouts:	Allows the operator to lock out the clean, freeze, and night function so that on the home screen when the button is pressed the unit will not react. Operator can select "Yes" or "No" to lockout the following functions.
	Freeze Mode Y or N Clean Mode Y or N Night Mode Y or N

7

Operator Display Menus (continued)

Screen Settings:	Operator can select "Yes" or "No" to the following functions: Show alternate moon (shape) Y or N Use Beep Function Y or N (Unit will or will not beep when a button is pressed) Show Hopper Temperature Y or N (Will or will not display hopper temp. on home screen)
Date/Time:	Allows user to set the Real Time Clock and current date in the unit.
Last Clean*:	Displays the last time the unit has been cleaned
Software Versions:	Has current software version numbers for both the U.I. and Main board Main _____ U.I. _____
Exit:	Press "Exit" button to escape any screen

*Your freezer has the ability to record a cleaning cycle event. In order to accomplish this, the following conditions must be met:

- A) The "Power Switch" must be in the "OFF" position.
- B) Dispense head must be removed for 10 minutes.
- C) The freezer cylinder temperature must be above 55°F.
- D) "Mix Low" must be indicated on the display screen.

8 Disassembly and Cleaning

CAUTION

To avoid electrical shock or contact with moving parts, make sure the control pad is "OFF" and that the power switch is "OFF".



The cleaning and sanitizing instructions explained in this manual are required to maintain a clean, sanitary freezer. The freezer should be disassembled, cleaned, reassembled, lubricated and sanitized daily to ensure the best possible product quality and freezer operation.

It is important that the freezer be disassembled, washed, lubricated and sanitized before operation.

Persons assembling, cleaning, or sanitizing the freezer must wash and sanitize hands and forearms with an approved sanitizer.

8.1 Cleaning Accessories

The following accessories shipped with the freezer are necessary for cleaning, sanitizing and disassembly/assembly.

- | | |
|---|--|
| <p>① HC150009 BRUSH.
HC158012 HANDLE.
4-inch diameter with 36-inch handle, used for cleaning the cylinder.</p> <p>② HC158077 BRUSH.
9/16 inch with 36 inch handle, used for cleaning the drain tube.</p> <p>③ HC158003 BRUSH.
Double end, 1-1/8 inch diameter and 7/16 inch diameter, used for cleaning the mix inlet tube, mix feed tube, head and general cleaning.</p> | <p>④ HC169374 TOOL - O-RING REMOVAL.
Aids in removing O-rings from plungers, dispense head, and mix feed tube.</p> <p>⑤ HC158000A LUBRICANT - PETROL GEL.
Approved lubricant for moving parts and O-rings. See assembly instructions for lubricating points.</p> <p>⑥ HC115536 KIT - O-RING. (NOT SHOWN)
This kit contains all O-rings and seal needing replacement on a regular basis.</p> |
|---|--|

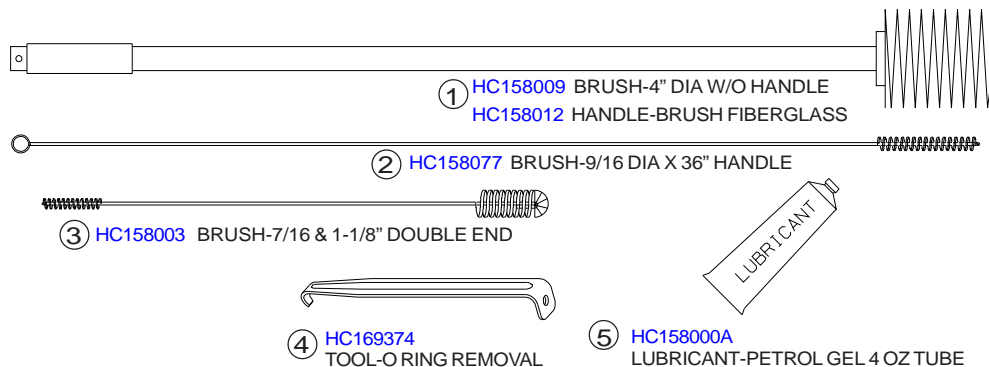

Figure 8-1 Accessories

8.2 Disassembly Instructions



CAUTION

To avoid electrical shock or contact with moving parts, make sure the control pad is "OFF" and that the power switch is "OFF".

It is important that the freezer be disassembled, washed, lubricated and sanitized before operation. For maximum life on moving parts, disassemble and sanitize at the end of every day of operation.

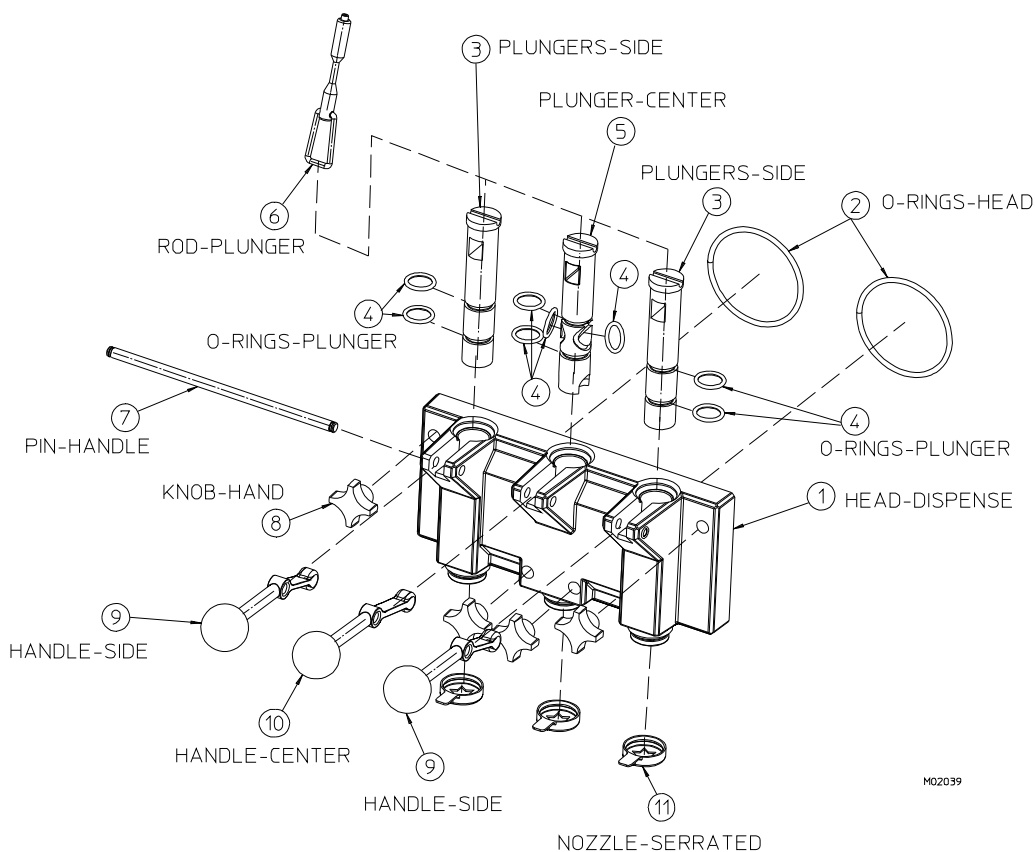

Figure 8-2

1. If there is product in the freezer, refer to Section 11, Closing Procedures, 11.2 Draining Product.

2. Remove plunger rods (6, figure 8-2) by lifting up and swinging the bottom out and down.

3. Remove the hand knobs (8) and gently pull the dispensing head (1) straight out.

4. Remove the beater shaft (1, figure 8-3) from each cylinder. Then remove breaker bar (1), scraper blades (3,4) and shaft seal (3,4) from the beater shafts. Remove the cup seals (4) from the washer (5) on the shaft seal assembly.

— continued

8.2 Disassembly Instructions (continued)

3. From the dispense head (1, figure 8-2) remove the handle pin (7), handles (9,10), plungers (5,3) and nozzles (11). Remove head o-rings (2) and the o-rings from plungers (4).

5. Remove hopper cover, drip tray and insert.

6. Remove the mix feed tube (figure 8-4) from the hopper.

Caution



To prevent bacteria growth, remove all O-rings when cleaning. Failure to do so could create a health hazard.

7. Remove the O-rings (3) from the mix feed tube (1). Remove the regulator (2) from the mix feed tube.

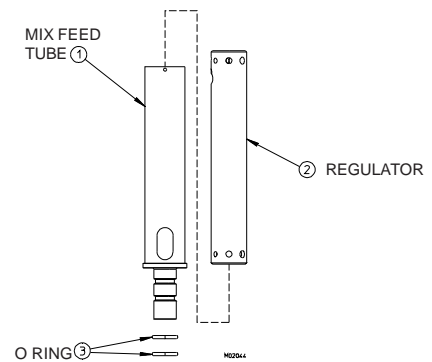

Figure 8-4

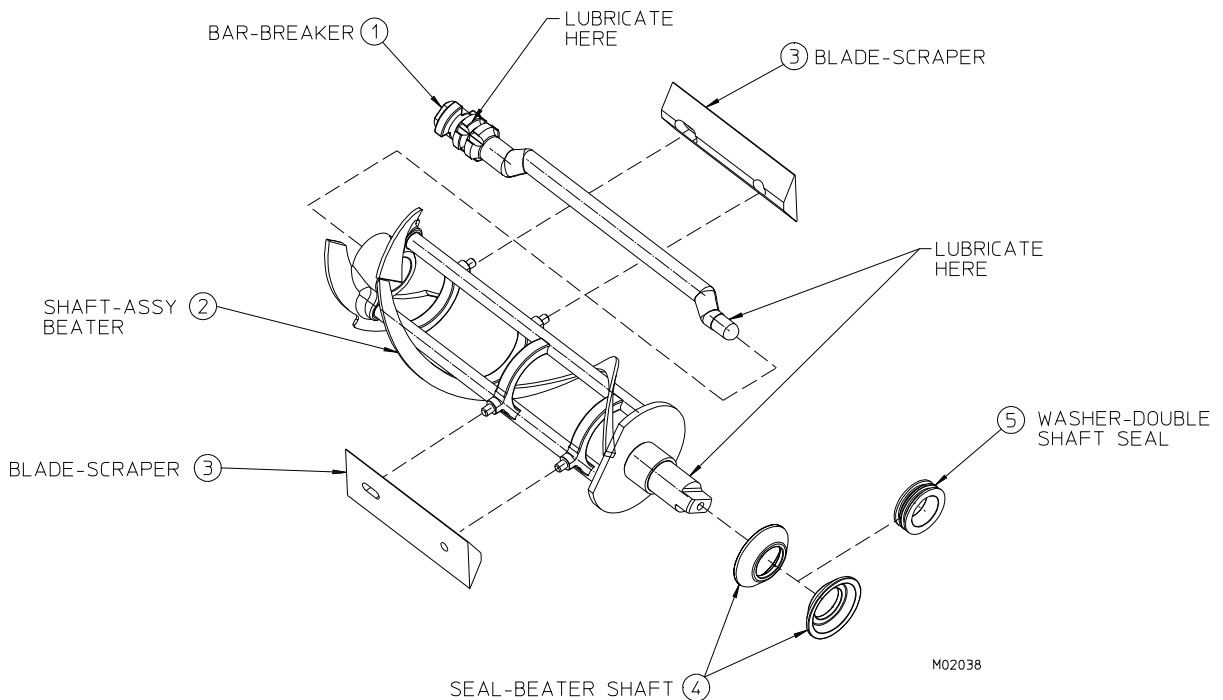

Figure 8-3

8.3 Cleaning Instructions

The cleaning instructions explained in this section are procedures to remove bacteria and maintain a clean, sanitary freezer. The soft serve freezer must be disassembled, washed and sanitized according to the instructions in this manual. Always sanitize before start-up to ensure the best possible cleanliness.



CAUTION

Electric shock hazard. Do not splash water on the control panel or allow water to flow onto electrical components inside the machine.



CAUTION

To prevent bacteria growth, remove all o-rings when cleaning. Failure to do so could create a health hazard.

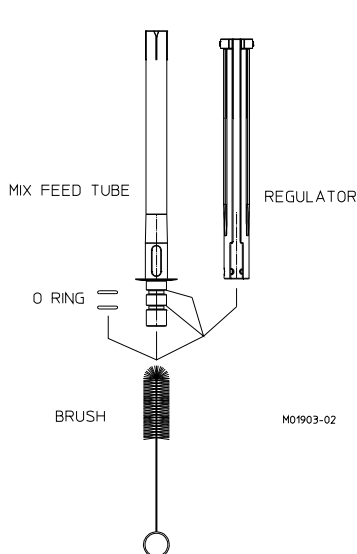

Figure 8-5 Clean the mix feed tube

NOTE: It is your responsibility to be aware of the requirements for meeting federal, state, and local laws concerning the frequency of cleaning and sanitizing the freezer.

1. Prepare a three-compartment sink for washing, rinsing, and sanitizing parts removed from the freezer, per applicable health codes. Also, prepare a clean surface to air-dry all parts.

Important:

Do not use unapproved sanitizer or laundry bleach. These materials may contain high concentrations of chlorine bleach and will chemically attack freezer components.

NOTE: The sanitizer should be mixed according to the manufacturer's instructions to yield 100 parts per million (PPM) available chlorine solution. (example: Stera Sheen Green Label). Use warm water (100 to 110°F or 38 to 43°C) to wash, rinse, and sanitize. Make sure the sanitizer is mixed thoroughly and has completely dissolved.

2. Wash all parts removed from the freezer thoroughly with a warm, mild dish detergent solution. Clean the following parts with the appropriate supplied brush:

a. The mix feed tube, regulator main bore and cross holes (figure 8-5).

b. The head plunger openings, center plunger ports, breaker bar cavities, o-ring grooves, dispense nozzle mounting rings and mix ports (figure 8-6).

c. The shaft seals, washers, plunger o-ring grooves and nozzles (figure 8-7).

d. The beater shaft inside the front collar and the hole on the rear flange (figure 8-8).

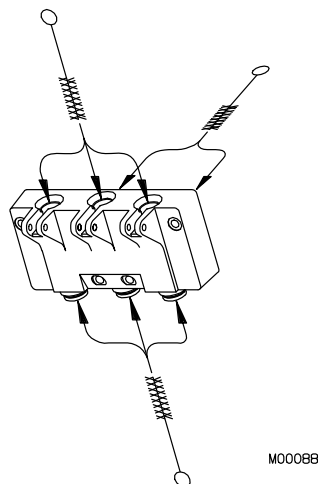

Figure 8-6 Clean the head ports

— continued

8.3 Cleaning Instructions (continued)

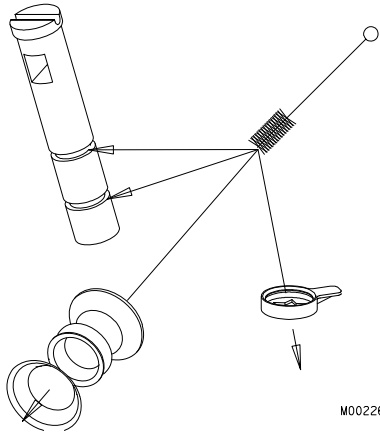

Figure 8-7 Clean shaft seal, washer, plunger, and nozzle

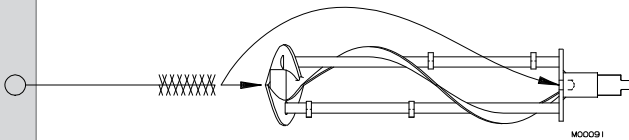

Figure 8-8 Clean beater shaft

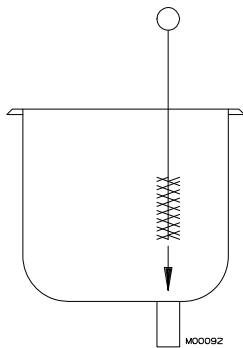

Figure 8-9 Clean hopper and mix feed port

Replace worn brushes. Use only Electro Freeze original or authorized replacement parts.

3. Rinse parts with clear water and place in sanitizing solution for 5 minutes.

Important:
Do not leave parts in sanitizer for more than 15 minutes.

4. Place parts on a clean surface and allow to air dry

5. Using a warm mild dish detergent thoroughly brush:

a. the hoppers and the mix feed tubes from the hopper to the cylinders. (figure 8-9).

b. the inside of the cylinders making certain to clean the back walls with 4" diameter brush provided.

c. the inside of the drain tube (figure 8-10). Dip the brush in the dish detergent solution and force brush into the drain tube until it stops - repeat until clean.

6. Repeat step 5 using a brush to rinse with water and then brush with sanitizing solution.

7. Remove the drip tray and insert. Wash in a warm dish detergent solution, rinse with clear water and place in sanitizing solution for 5 minutes.

8. Wash the outside of the freezer and inside of the cabinet with a warm dish detergent solution. Rinse with water

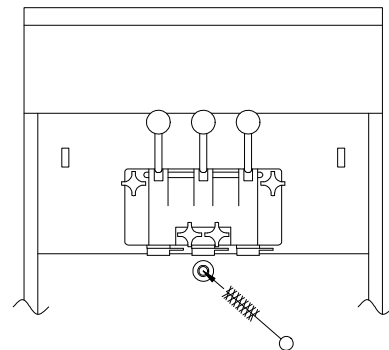

Figure 8-10 Clean inside of drain tube

9 Assembly

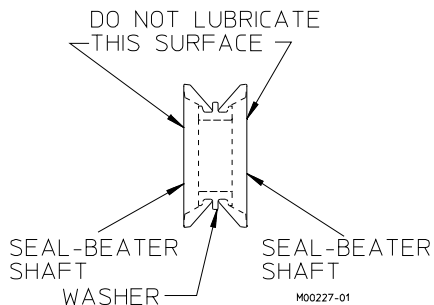



Figure 9-1 Lubricate shaft seal

Correct assembly of the freezer is essential to prevent leakage of the product and damage to the freezer. To assemble the freezer you will need an approved lubricant, such as Petrol Gel. Make sure all parts of the assemblies have been washed and sanitized before assembling. Follow these directions for each cylinder of the freezer.



CAUTION
To avoid electrical shock or contact with moving parts, make sure the control pad is "OFF" and that the power switch is "OFF".

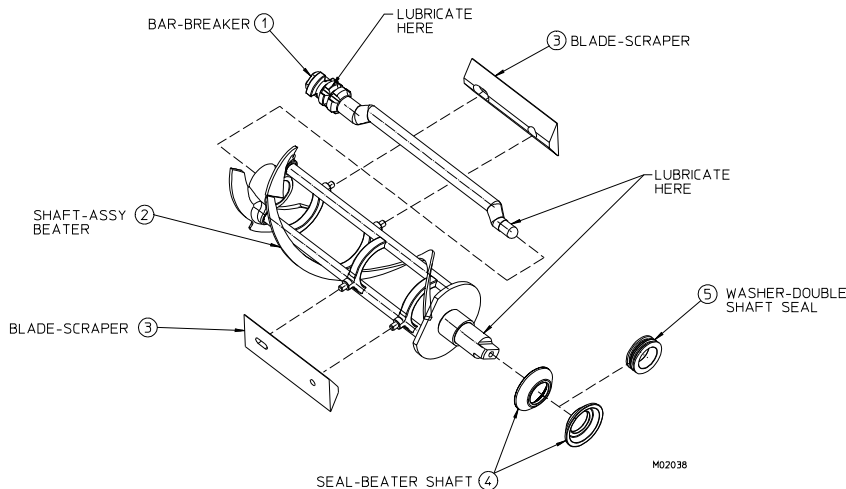

Figure 9-2 Assemble beater shaft assembly

1. Persons assembling the freezer must first wash and sanitize their hands and forearms with an approved sanitizer.

2. To assemble the shaft seal, install the cup seals on the plastic washer as shown in figure 9-1.

3. Apply a moderate amount of approved sanitary lubricant (such as Petrol Gel) to the beater shaft as shown in figure 9-2. Install the shaft seal over the rear of the beater shaft, (figure 9-2). Do not allow any lubricant to come in contact with the bell-shaped rubber portions of the shaft seal.

4. Apply lubricant to the bearing areas of the breaker bar (figure 9-3).

5. Place the scaper blades on the beater shaft, making sure the blades are installed properly.

6. Slide the breaker bar into the center of the beater shaft, making sure the bar fits into the hole in the rear beater shaft disc (figure 9-2).

7. Insert the assembled beater shaft into the cylinder by placing the rear blade on the bottom of the cylinder. This will center the beater shaft and allow alignment with the drive coupling. Rotate the beater assembly while pushing, until the shank has engaged the coupling. Install both beater shafts.

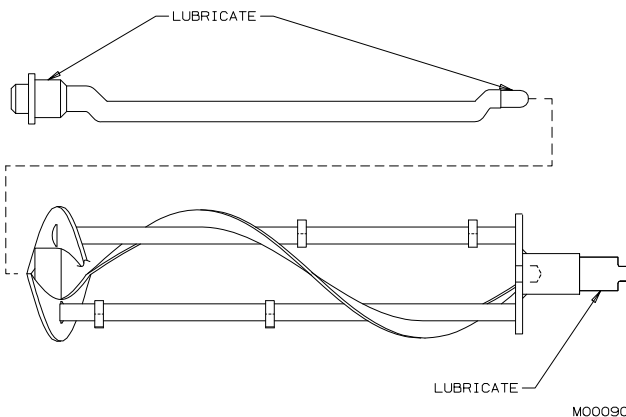
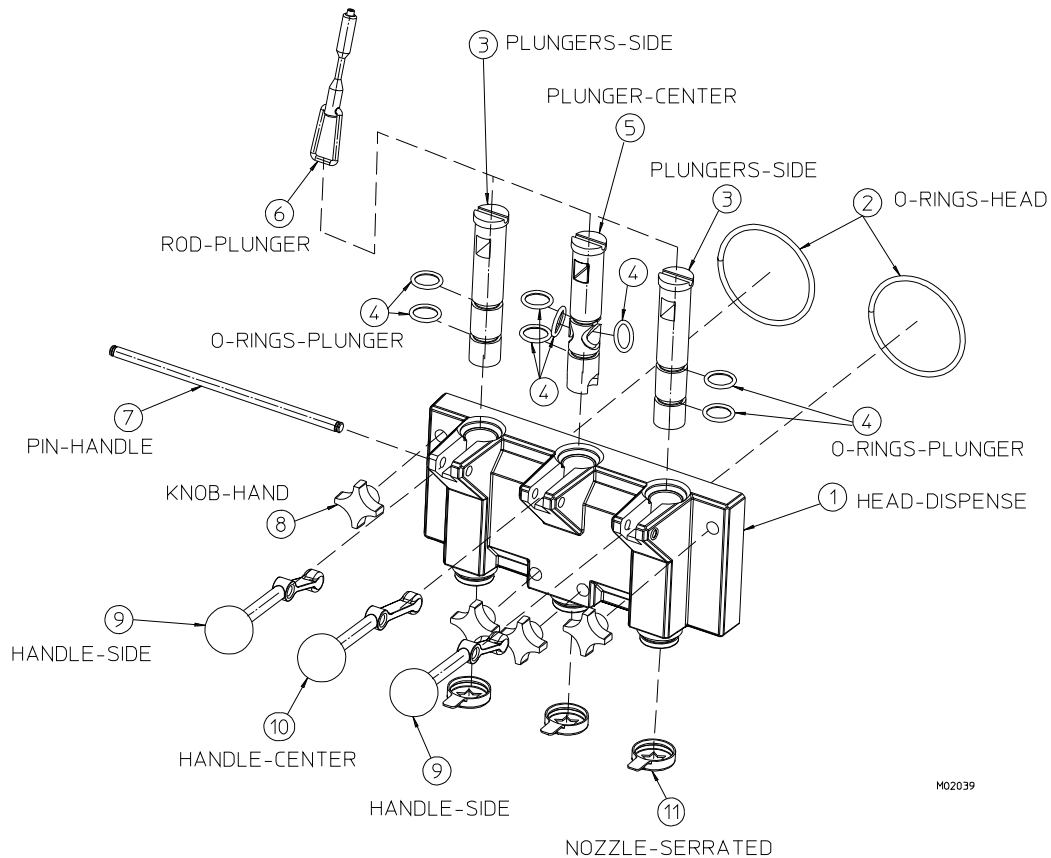

Figure 9-3 Lubricate bearing areas of breaker bar

— continued

9 Assembly (continued)



Note: Item 10 center handle is longer.

Figure 9-4 Head Assembly

8. Install and lubricate the O-rings (4, figure 9-4) (see O-ring Chart - Replacement Parts Manual) on the dispensing plungers (4,5) and insert half-way into the head (1).

9. Install and lubricate the two 4-inch head O-rings (2).

10. Position the handles in the head assembly by placing the 2 shorter handles (9) on the sides and the longest handle (10) in the center. Lock in place with the handle pin (7).

11. Install the dispensing head onto the freezer by aligning the studs with the holes in the head and sliding toward the freezer. Tighten hand knobs evenly, finger-tight only.

12. Install the plunger rods (6). The nozzles (11) will be installed on the mix outlet at the bottom of the head after sanitizing.

13. Install the o-rings (3) on the mix feed tube (1). Lightly lubricate the o-rings as shown in figure 9-5.

Important:
Excessive force will damage the head. Do not use tools to tighten.

— continued

9 Assembly (continued)

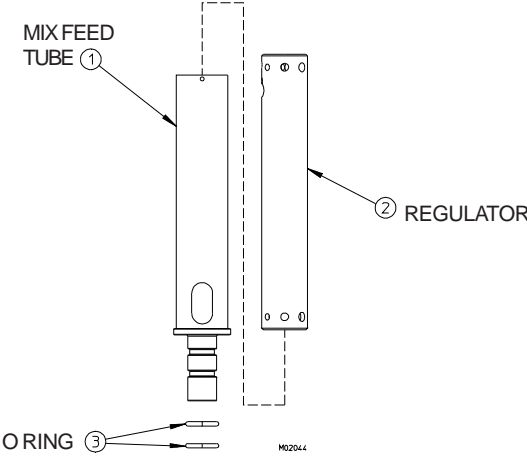

Figure 9-5 *Mix Feed Tube Assembly*

14. Re-install drip tray and insert on the freezer.

10 Start-up Instructions

10.1 Sanitizing

The washing and sanitizing instructions explained in this section are procedures to remove bacteria and maintain a clean, sanitary freezer. The freezer must be disassembled and washed according to the instructions in this manual before sanitizing to ensure the best possible cleanliness. Follow these directions for each cylinder to be used.

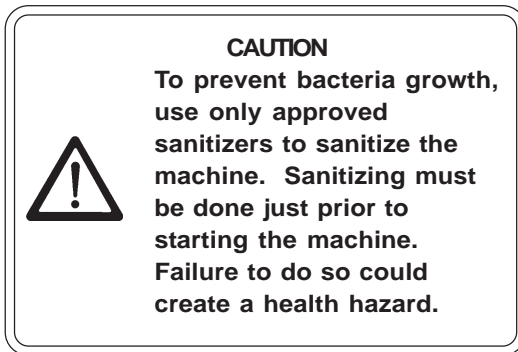

NOTE: It is your responsibility to be aware of and conform to the requirements for meeting federal, state and local laws concerning the frequency of cleaning and sanitizing the freezer.

Important:
This sanitizing step is always done just prior to starting the freezer.

1. Wash and sanitize your hands and forearms.

2. Prepare 2 gallons (7.6 liters) of sanitizing solution for each hopper. The sanitizing solution must be mixed according to manufacturer's instructions to yield 100 PPM (parts per million) available chlorine solution (example: Stera-Sheen Green Label). Use warm water (100-110°F or 38-43°C) to wash, rinse, and sanitize. Make sure sanitizer is mixed thoroughly and has completely dissolved.

Important:
Do not use unapproved sanitizers or laundry bleach. These materials may contain high concentrations of chlorine and will chemically attack freezer components.

3. Place the mix feed tubes and regulators in the bottom of the hopper pans. Do NOT place regulator into the mix feed tube. See figure 10-1.

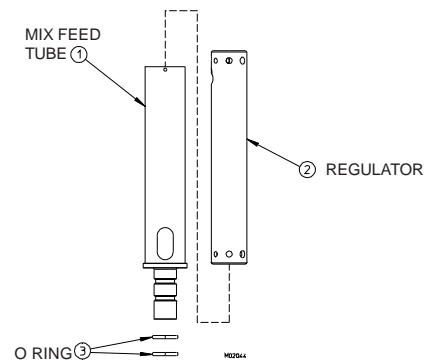

Figure 10-1 Mix Feed Tube Assembly

Important:
Never let the sanitizer remain in the freezer for more than 15 minutes.

Important:
Do not insert any tools or objects into the mix feed port or head dispensing hole while the freezer is running.

4. Pour 2 gallons of sanitizing solution into each hopper pan. Using a clean brush, scrub the hopper walls, mix level sensors and the mix feed ports from the hoppers to the cylinders, as shown in figure 10-2.

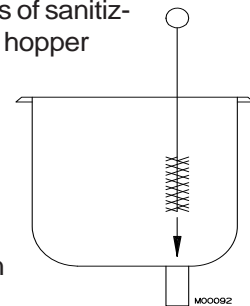

Figure 10-2 Sanitize hopper and its components

—continued

10.1 Sanitizing (continued)

5. Sanitize the inside of the hopper covers.

6. Reconnect main power supply. Place the power switch in the “ON” position.

Important:

Do not use the  freeze position with water or sanitizer in the cylinder. The freezer will be damaged.

7. When the cylinders have filled with sanitizing solution, press the  and “BEATER ON” for both sides of the freezer and allow the beaters to run for 5 minutes. During this time period, check for leaks around the head, plungers and drain tubes.

8. Press “BEATER OFF” on both sides. Place an empty container under the dispensing head and drain the sanitizing solution by opening the plungers to allow cylinders and hoppers to empty. Open and close each plunger at least 10 times during draining to sanitize the port area of dispense head.

9. When the sanitizing solution has drained from the freezer, press the  “OFF” button.

10.2 Priming

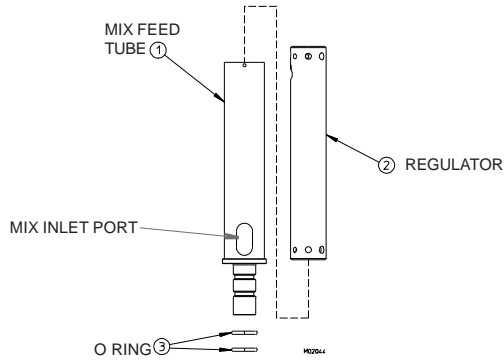

Figure 10-3 Mix Feed Tube Assembly

Priming the freezer removes all excess sanitizer from the freezing cylinder, and sets the proper overrun for the first cylinder of product.

1. Make sure that your hands, fore-arms, and all freezer assemblies are sanitized.
2. See figure 10-3. Insert the regulator into the mix feed tube assembly. Place mix feed tube on sanitized surface. Set to desired port size number. Larger holes are for thicker products. Insert the mix feed tube assembly into the hopper drain outlet.
3. Proceed to instructions in section 10.2.1 or 10.2.2 depending on freezer setup.

10.2.1 Standard Priming Instructions

1. Place a bucket under the dispense head.
2. While filling the mix hopper with one gallon of mix open the plunger by pulling the dispense handle down and allow mix to push out remaining sanitizer. When pure mix is flowing from the dispense head close the dispense handle (figure 10-4).

Important:

Failure to completely remove sanitizer or water from the freezing cylinder before placing in  freeze will damage the freezer.

3. Allow mix to continue flowing into the cylinder until the mix in the hopper stops bubbling. Insert mix feed tube assembly.
4. Press the  freeze button to start the freezer.
5. Repeat Steps 1 - 4 for the other side of the freezer.
6. Sanitize and install nozzles.

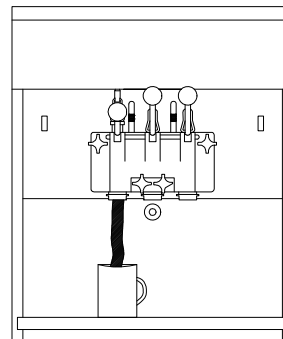

Figure 10-4 Pure mix

10.2.2 Priming Instructions for Freezers Built into a Wall

1. Place a bucket under the dispense head. Remove the actuator rod from the spigot. Leave spigot open. (figure 10-4)
2. Fill mix hopper with one gallon of mix and allow mix to push out remaining sanitizer. When pure mix is flowing from the dispense head close the dispense handle (figure 10-4). Reinstall the actuator rod.

Important:

Failure to completely remove sanitizer or water from the freezing cylinder before placing in ❄️ freeze will damage the freezer.

3. Press the ❄️ freeze button to start the freezer..
4. Repeat Steps 1 - 3 for the other side of the freezer.
5. Sanitize and install nozzles.

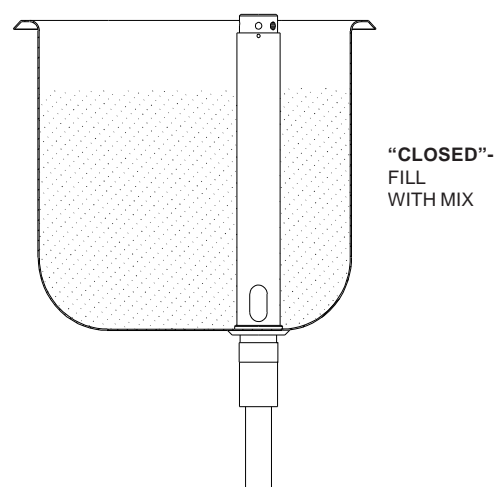
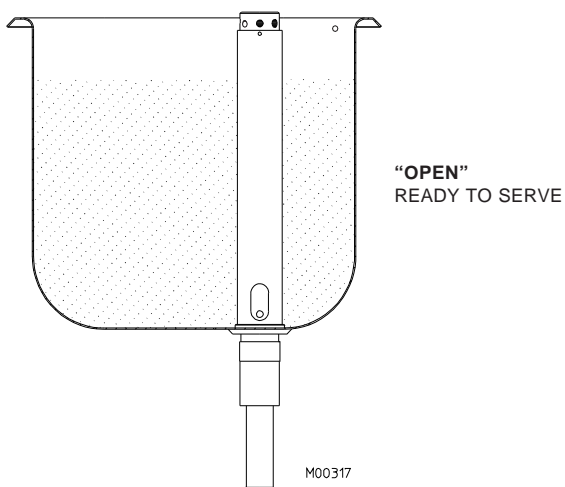

Figure 10-5 “OPEN” — position

Figure 10-6 “CLOSED” — position

11 Closing Procedures

11.1 Night Switch Operation

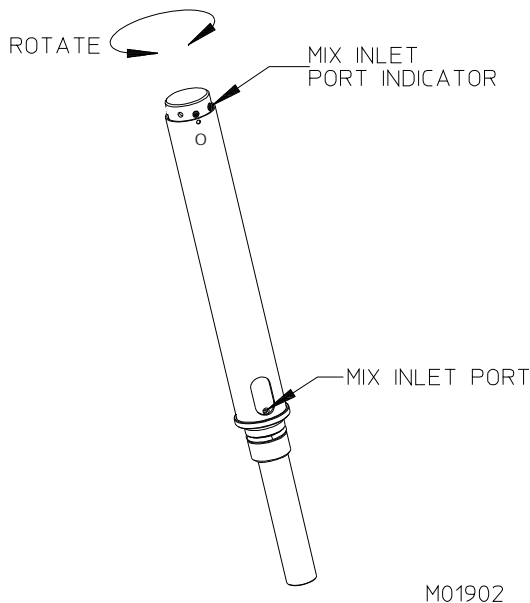

Figure 11-1 Mix Feed Tube Positions

1. In areas where state and local health codes allow, the freezer may be switched to night operation, which will allow the freezer to cycle all night and maintain 40°F (4°C) or lower product in the cylinder and hopper.

2. To switch the freezer to the night mode, press the  "NIGHT" button.

3. Remove nozzles, and clean the drip tray assembly and all soiled surfaces with soap and water. Use sanitizing solution in a spray bottle and brush to clean the bottom of the plunger openings.

4. Turn the mix feed regulator to the "CLOSED" position.

5. Check mix level in hopper to ensure that there is enough mix to keep the indicator light off, add mix if necessary. **Do not dispense product when the mix feed regulator is in the "CLOSED" position.**

6. To start the machine after using the "NIGHT" mode, press  freeze button and replace the sanitized nozzles.

7. "OPEN" the mix feed regulator and fill the hopper with mix.

11.2 Draining Product from Freezer

Note: It is your responsibility to be aware of and conform to the requirements for meeting local, state, and federal laws concerning the frequency of cleaning and sanitizing the freezer.

To remove frozen product from the cylinders, perform the following steps:

1. On the control panel press  and then the "BEATER ON" button for both sides of the freezer.
2. Let the beaters run for 5 minutes. This will allow the product in the cylinders to soften.
3. Remove mix feed tubes from the hoppers.
4. Place a clean, sanitized container under the dispensing nozzles.
5. Dispense the semi-frozen product until it quits dispensing. If local health codes permit, cover the rerun product container and place it in the cooler. (See Section 10, SOFT SERVE INFORMATION)

Important:
Do not use hot water. Damage to the freezer could occur.

6. Close plungers and pour two gallons of cold water into each hopper.

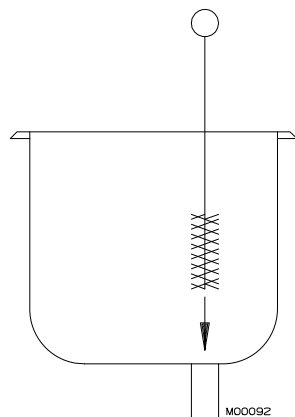

Figure 11-2 Sanitize hopper

7. Dispense the cold water. Brush residue off hopper walls and drain.

8. Repeat with warm water until the water dispensed is clear.

9. Drain the remainder of the warm water from the cylinder. Press "BEATER OFF" button for each side.

10. Prepare 2 gallons (7.6 liters) of sanitizing solution for each hopper. Sanitizing solution must be mixed according to manufacturer's instructions to yield 100 PPM available chlorine solution (example: Stera- Sheen Green Label).

11. Pour sanitizing solution into the hopper pan. Using a clean brush, scrub the hopper walls, mix level sensor, and the mix feed port from the hopper to the cylinder, as shown in figure 9-3.

Important:
Do not use the  the freeze position with water or sanitizer in the cylinder. The freezer will be damaged.

12. When the cylinder has filled with sanitizing solution, press "BEATER ON" and allow the beater to run for 5 minutes.

13. Place an empty container under the dispensing head and drain the solution by opening the plunger to allow cylinder and hopper to empty.

14. When the sanitizing solution has drained from the freezer, press "BEATER OFF". Place the power switch to the "OFF" position.

15. Proceed to disassembly, cleaning and sanitizing instructions.

12 Soft Serve Information

12.1 Overrun

As mix is frozen in the freezing cylinder, air is incorporated into the mix to increase its volume, as well as enhance the taste and texture of the finished product. The increase in volume is called overrun. Fifty percent overrun translates to a volume increase of 50% — 10 gallons of liquid mix has become 15 gallons of finished product.

Controlled overrun is important to maintain consistency in product quality. Too much overrun (air) results in a light, fluffy product lacking the cold, refreshing appeal of a quality product. Too little overrun results in a wet, heavy product.

To correctly measure the overrun perform the following steps:

1. Place an empty pint container on the scale* and adjust your scale to zero.
2. Remove container from scale and fill the container to the top with liquid mix. Place container on scale and record the weight.

3. Replace liquid mix with frozen product, being sure to leave no voids or air spaces in the container.

4. Strike off the excess product so it is even with the top of the container and measure the weight.

5. Use the following formula to figure overrun percentage:

“Weight of liquid mix minus weight of frozen product/divided by the frozen weight. Multiply by 100.” See example.

Example:

Weight of 1 pint of mix = 18 oz.

Weight of 1 pint frozen product = 12 oz.

Difference = 6 oz.

6 oz. divided by 12 oz. = .5

.5 x 100 = 50% overrun

*Your Electro Freeze Distributor can provide a scale (P/N HC158049) that is graduated in overrun percentage.

12.2 Rerun

Rerun is product that has been drawn through the freezer into a container and has melted down to be re-processed. If local health codes permit the use of rerun make sure to follow these procedures:

1. Store rerun mix in a clean, sanitized container.
2. Store in a cooler with a temperature below 40° F (4.4° C).
3. DO NOT prime the machine with rerun. Always skim off and discard foam — then mix the rerun with fresh mix in a ratio of 50/50 and add to the hopper during operation.

4. Once a week, run the mix as low as possible and discard after closing. Product from Freezer (see Section 9.2). This will break the rerun cycle and reduce the possibility of high bacteria and coliform counts.

NOTE: Rerun product is unable to accept the same amount of air as fresh product. As a result, the quality will be affected and the product may appear grainy and icy.

For further information contact your local Electro Freeze Distributor or the Service Department of H. C. Duke & Son, LLC. at (309) 755-4553, (800) 755-4545, or e-mail service@electrofreeze.com.

13 Routine Maintenance

Electro Freeze recommends the following schedule to help maintain your freezer in like-new operating condition. Take the time to learn and perform these routine procedures and receive in return many years of valuable service from your freezer. *Protect your investment!*

DAILY

1. Disassemble, wash, rinse, sanitize, air dry, reassemble and sanitize all parts which come into contact with the mix.



CAUTION

To prevent bacteria growth, remove all O-rings when cleaning. Failure to do so could create a health hazard.

2. Clean the cylinder and drain tube with the appropriate brushes.
3. Upon cleaning, inspect and lubricate all seals and O-rings as instructed that come into contact with mix. Replace any O-ring that is worn, torn, or loose-fitting.
4. Wipe all exterior surfaces of the freezer to remove any splattered mix.
5. Check overrun and temperature of the product.

WEEKLY

1. Carefully inspect all parts for wear, including seals, o-rings, and blades. Replace as required. Replace blades if worn $\frac{3}{16}$ (5mm) or more.

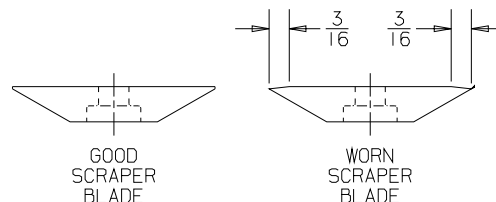

GOOD
SCRAPER
BLADE

WORN
SCRAPER
BLADE

2. Check the beater tangs and drive shaft for wear.

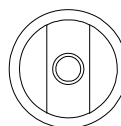

GOOD BEATER
SHAFT TANG

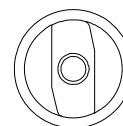

WORN BEATER
SHAFT TANG

A worn coupling will have a nonparallel shape on the drive opening.

1500 HOURS OF OPERATION

1. **Gear Reducer - Initial Oil Change**
Have the oil in the gear reducer changed by your Electro Freeze Distributor.

13 Routine Maintenance (continued)

MONTHLY

1. Test Head Switch.

The head switch feature is designed to prevent the beater shaft from being accidentally activated. It is essential that the proper operation of this switch be verified on a routine basis. Use the following instructions to test for proper operation. Check each side of the freezer using this procedure.

1. Be sure all switches are in the "OFF" position.
2. Disconnect the main power supply.
3. Remove the dispense head and beater shaft assembly.
4. Connect the main power supply.
5. Turn the selector switch to the "CLEAN" position.



CAUTION
Moving parts. **DO NOT** place hands in the freezing cylinder. Severe personal injury could result.

6. Look inside the freezing cylinder toward the rear, the drive shaft coupling should **NOT** be turning. Turn the switch "OFF" and disconnect the main power supply.

7. If the drive shaft coupling is turning, or you are unable to determine whether or not the shaft is turning, turn the switch to the "OFF" position, disconnect the main power supply and contact your Electro Freeze distributor for service. **DO NOT** place the freezer in service until the problem has been fixed.

2. Water Condenser.

Check the outlet water temperature of water-cooled condensers at the floor drain. Water temperatures should be about 95°F (35°F) with a 70° (21°F) water inlet temperature.



13 Routine Maintenance (continued)

QUARTERLY

1. Have your Electro Freeze Distributor check the refrigeration system and make the necessary adjustments.

2. Both air and water cooled freezers have an air condenser. The condenser fins need to be cleaned by your Electro Freeze Distributor to remove all forms of dirt, lint, and dust.

Important:

Never use a screwdriver or sharp object to clean between fins.

SEMIANNUALLY

1. Contact your Electro Freeze distributor to replace drive belts.

2. On air cooled and air cooled remote freezers have your Electro Freeze distributor check the condenser fan motor oil.

2. Have the gear reducer oil changed by your Electro Freeze distributor.

NOTE: Under normal conditions, after the initial change, the oil should be changed after every 2500 hours of operation or every six months, whichever occurs first.

ANNUALLY

CAUTION

To avoid electrical shock or contact with moving parts, make sure the control pad is "OFF" and that the main power switch is "OFF".



1. Contact your Electro Freeze Distributor to have your gear reducer oil changed.

NOTE: Under normal conditions, after the initial change, the oil should be changed after every 5000 hours of operation or every year, whichever occurs first.

2. Contact your Electro Freeze Distributor for service to replace drive belts and lubricate the fan motors as needed.

3. Contact your Electro Freeze Distributor to clean the inside of the freezer, including base, side panels, condenser, etc.

4. Contact your Electro Freeze Distributor to check water-cooled condenser and flush clean to remove scale and deposits if necessary.

13 ROUTINE MAINTENANCE

WINTER STORAGE

To protect the unit during seasonal shutdown, it is important to store the freezer properly. Use the following procedures:

1. Disconnect all power to the freezer.
2. Disassemble and wash all parts that come into contact with the mix using a warm, mild detergent solution. Rinse in clear water and air dry all parts thoroughly. Clean drain tube and all exterior panels.
3. Store the loose parts, such as the head assembly and beater assembly, in a safe dry place.
4. Do not lay heavy objects on the plastic or rubber parts.
5. Cover the freezer and all loose parts to protect them from dust or other elements that could contaminate them while in storage. Place the freezer in a dry location.
6. If you have an air cooled freezer, have condenser fins cleaned by an authorized service technician.
7. On water-cooled freezers, disconnect the water supply. Use compressed air to blow out all remaining water in the condenser.

Important:

The water valve must be opened in order to blow out the condenser. Failure to purge the freezer of water can result in severe damage to the refrigeration system. Call your Electro Freeze Distributor for service.

8. When freezer is restarted after seasonal shutdown, remember to replace all o-rings and seals with new parts. Rubber parts can lose their elasticity and ability to seal when stored.

USE ONLY ORIGINAL OR AUTHORIZED REPLACEMENT PARTS WITH THIS FREEZER.

If you have any questions on items that are not included in this schedule or problems that require service assistance, please call your local distributor or H.C. Duke & Son, LLC, *Electro Freeze*, Service Department for factory service assistance.

Phone: (309) 755-4553 or (800) 755-4545

FAX: (309) 755-9858.

E-mail: service@electrofreeze.com

14 Trouble Shooting Tables

SAFETY



THIS SAFETY ALERT SYMBOL IDENTIFIES IMPORTANT PERSONAL SAFETY MESSAGES IN THIS MANUAL. WHEN YOU SEE THIS SYMBOL, BE ALERT TO THE POSSIBILITY OF PERSONAL INJURY. DO NOT ATTEMPT TO CONTINUE UNTIL THE SAFETY PRECAUTIONS ARE THOROUGHLY UNDERSTOOD.



CAUTION

All maintenance adjustments must be done by an Electro Freeze distributor or authorized service technician.



CAUTION

To avoid electrical shock or contact with moving parts, make sure all switches are in the "OFF" position and that the main power supply is disconnected. Some freezers have more than one disconnect switch.



Important:

Some refrigerants are hazardous to the Earth's atmosphere. To protect our environment, use a refrigerant recovery/recycling unit when removing refrigerant from the system.



14

Trouble Shooting Tables (continued)

PROBLEM	PROBABLE CAUSE	REMEDY
Unit does not operate.	1. Freezer unplugged.	1. Plug in freezer.
	2. Fuse or breaker blown at main disconnect.	2. Make sure your freezer is connected to a separate circuit independent from any other electrical equipment. Have technician check fuse or breaker size and check voltage; if not within 10% of nameplate rating call power company.
	3. Off on high pressure cut-out control.	3. Refer to Troubleshooting Table – Discharge pressure too high.
	4. Off on low pressure cut-out control.	4. Contact your Electro Freeze distributor for service.
	5. Disconnected or broken wire in electrical circuit.	5. Contact your Electro Freeze distributor for service.
Leakage of mix or water from drain tube to drip tray. 	1. Damaged beater shaft seal or installed improperly.	1. Replace cup seals on washer. Install properly.
	2. Beater shaft pitted or damaged where o-ring rides.	2. Replace beater shaft.
	3. Beater shaft end play not set properly.	3. Contact your Electro Freeze distributor for service.
Compressor does not operate or operates improperly. 	1. Faulty contactor.	1. Contact your Electro Freeze Distributor for service.
	2. Disconnected or broken wire in switch.	2. Contact your Electro Freeze Distributor for service.

14

Trouble Shooting Tables (continued)

PROBLEM	PROBABLE CAUSE	REMEDY
Dispensed product too soft.	1. Dirty or blocked condenser, restricted air flow.	1. Unblock condenser or have cleaned by your Electro Freeze distributor.
	2. Component failure.	2. Contact your local service company.
	3. Leak in refrigeration system resulting in little or no refrigeration.	3. Contact your local service company.
Product dispenses slowly out of dispensing head.	1. Product too cold.	1. Check product temperature. Should be 17° to 19°F (-8 to -7°C). See Troubleshooting Table - Dispensed product too hard.
	2. Dispensing speed adjustment bolt too far down.	2. Contact your Electro Freeze distributor for service.
	3. Wrong rotation on beater.	3. Have an electrician correct rotation to clockwise as viewed from the front of the freezer.
Dispensed product too hard.	1. Controls are set too cold.	1. Contact your Electro Freeze distributor for service.
	2. Plunger switch electrically or mechanically stuck closed.	2. Contact your Electro Freeze distributor for service.
	3. Low suction pressure.	3. Contact your Electro Freeze distributor for service.

14

Trouble Shooting Tables (continued)

PROBLEM	PROBABLE CAUSE	REMEDY
Freezer runs continually and product gets too cold.	1. Plunger switch rod engaged.	1. Close plunger completely.
	2. Plunger switch (side or center) out of adjustment or defective.	2. Contact your Electro Freeze distributor for service.
	3. Starter points stuck.	3. Contact your Electro Freeze distributor for service.
	4. Suction pressure too low.	4. Contact your Electro Freeze distributor for service.
Compressor does not operate or operates improperly.	1. Trouble in compressor condensing circuit.	1. See Troubleshooting Chart-Compressor/Condensing Circuit Section 16.1
	2. Faulty start capacitor, run capacitor or relay. (Single phase only)	2. Contact your Electro Freeze Distributor for service.
	3. Faulty contactor.	3. Contact your Electro Freeze Distributor for service.
	4. Disconnected or broken wire in switch or capacitor relay box.	4. Contact your Electro Freeze Distributor for service.
Compressor and beater motor do not operate when dispensing.	1. Plunger switch(es) defective or out of adjustment.	1. Contact your Electro Freeze Distributor for service.
	2. Out on HPCO or LPCO.	2. Contact your Electro Freeze Distributor for service.

14

Trouble Shooting Tables (continued)

PROBLEM	PROBABLE CAUSE	REMEDY
Compressor does not start – hums intermittently (cycling on overload).	1. Low line voltage.	1. Ask power company to check voltage, increase voltage to not less than 10% below data plate rating or install transformer. Have electrician check for inadequate wire size.
	2. Improperly wired.	2. Contact your Electro Freeze distributor for service.
	3. Open starting capacitor or current relay.	3. Contact your Electro Freeze distributor for service.
	4. High discharge pressure.	4. Contact your Electro Freeze distributor for service.
Poor or slow product recovery.	1. Dirty or blocked condenser, restricted air flow – high ambient temperature.	1. Have condenser cleaned by your Electro Freeze distributor; lower ambient temperature.
	2. Defective condenser fan motor.	2. Contact your Electro Freeze distributor for service.
	3. Component or compressor failure.	3. Contact your Electro Freeze distributor for service.
Beater motor does not operate. 	1. Head assembly is not installed.	1. Install head assembly.
	2. Magnetic head switch defective.	2. Contact your Electro Freeze Distributor for service.
	3. Loose connection in control circuit.	3. Contact your Electro Freeze Distributor for service.
	4. Open starter coil.	4. Contact your Electro Freeze Distributor for service.
	5. Faulty capacitor assembly. (Single phase only.)	5. Contact your Electro Freeze Distributor for service.
	6. Faulty beater motor.	6. Contact your Electro Freeze Distributor for service.

14

Trouble Shooting Tables (continued)

PROBLEM	PROBABLE CAUSE	REMEDY
Unit operates long or continuously.	1. Dirty condenser.	1. Have condenser cleaned by your Electro Freeze distributor.
	2. Shortage of refrigerant.	2. Contact your Electro Freeze Distributor for service.
	3. Moisture in system.	3. Contact your Electro Freeze Distributor for service.
	4. Compressor failing.	4. Contact your Electro Freeze Distributor for service.
Discharge pressure too high.	1. Water hose kinked or pinched. (water cooled models)	1. Move freezer and adjust hose so it is not pinched or kinked.
	2. Water turned off or defective water regulating valve. (water cooled models)	2. Turn on water, or contact your Electro Freeze Distributor for service.
	3. Restricted water cooled condenser. (water cooled models)	3. Contact your Electro Freeze Distributor for service.
	4. Dirty air condenser. (air cooled models)	4. Contact your Electro Freeze Distributor for service.
	5. Unit location too warm (air cooled models)	5. Contact your Electro Freeze Distributor for service.
	6. Refrigerant overcharge.	6. Contact your Electro Freeze Distributor for service.
	7. Air in system.	7. Contact your Electro Freeze Distributor for service.
Discharge pressure too low.	1. Water regulating valve open too wide. (water cooled model)	1. Contact your Electro Freeze Distributor for service.
	2. Shortage of refrigerant.	2. Contact your Electro Freeze Distributor for service.
Noisy compressor.	1. Tubing rattles.	1. Contact your Electro Freeze Distributor for service.
	2. Compressor spring broken internally.	2. Contact your Electro Freeze Distributor for service.

14.1

Virtual Quality Management (VQM) System Display Trouble Shooting Messages

What the display will read	Action taken in unit when error is present	Detailed description	Method to reset error	Probable cause of Error Code	Remedy
Comm. Error	System completely shuts down	The main P.C. board is not communicating with the U.I. board.	Disconnect unit main power and restore	1. Faulty wire connection 2. Programming issue 3. Defective board	Contact your Electro Freeze distributor for service.
Main Comm.	System completely shuts down	The main U.I. board is not communicating with the main P.C. board.	Disconnect unit main power and restore	1. Faulty wire connection 2. Programming issue 3. Defective board	Contact your Electro Freeze distributor for service.
Barrel Rfg.	Barrel Refrigeration shut down, Hopper refrigeration stays on	Barrel Refrigeration Error. This occurs when the system run time exceeds 45 minutes	Disconnect unit main power and restore	1. Dirty condenser 2. Shortage of refrigerant 3. Moisture in system. 4. Compressor failing 5. Faulty thermistor	Contact your Electro Freeze distributor for service.
Hopper Rfg	Barrel refrigeration switches to night mode. Hopper system cycles 5 min. on 90 min. off	Hopper Refrigeration Error. Occurs when hopper system run time exceeds 45 minutes	Disconnect unit main power and restore	1. Dirty condenser 2. Shortage of refrigerant 3. Moisture in system. 4. Compressor failing 5. Faulty thermistor	Contact your Electro Freeze distributor for service.
Barrel Temp	Affected Barrel enters night temp. cycle mode	Barrel Temperature Out. Occurs when barrel thermistor is above or below temp. limit for 1 minute without change	Disconnect unit main power and restore	1. Faulty thermistor 2. Refrigeration system malfunction	Contact your Electro Freeze distributor for service.
Hopper Temp	Affected barrel enters night temp. mode, hopper in time cycle mode	Hopper Temperature Out. Occurs when hopper thermistor is above or below temp. limit for 1 minute without change	Disconnect unit main power and restore	1. Faulty thermistor 2. Refrigeration system malfunction	Contact your Electro Freeze distributor for service.
Last Cones /Mix Low Alternates in screen	Count down number of Cones before Mix Out Condition	Mix Low. Occurs when low mix probe signal is detected for 30 sec.	Refill with mix to satisfy probe and unit auto resets	Hopper running low on mix	Re-fill unit with mix
MIX OUT	Affected Barrel Beeps to alert user of Mix Out Condition	Mix Out. Occurs when last cone value reached while in mix low condition	Auto reset after mix probe is satisfied	1. Hopper out of mix 2. Mix level control not functioning properly	1. Re-fill unit with mix 2. Contact your Electro Freeze distributor for service.

14.1

Virtual Quality Management (VQM) System Display Trouble Shooting Messages (continued)

What the display will read	Action taken in unit when error is present	Detailed description	Method to reset error	Probable cause of Error Code	Remedy
Head Switch	System completely shuts down	Head Switch Open. Occurs when head switch is open with power applied to unit (When freeze, night, or clean mode are selected	Auto reset after head switch is closed	<ol style="list-style-type: none"> 1. Head assembly not installed 2. Magnetic head switch defective 3. Loose wire connection 4. Programming issue 	<ol style="list-style-type: none"> 1. Install Head Assembly 2. Contact your Electro Freeze distributor for service.
Motor OVLD	Affected barrel enters off mode , hopper still operates	Motor Overload Open. Occurs when motor current is 0 when motor is given an on signal	Disconnect unit main power and restore	<ol style="list-style-type: none"> 1. Product too cold 2. Loose wire connection 3. Open starter coil 4. Faulty capacitor (1 ph. Only) 5. Faulty beater motor 	<ol style="list-style-type: none"> 1. Adjust product temperature 2. Contact your Electro Freeze distributor for service.
Motor Amps	Affected Barrel switches to night mode, while every 5 minutes unit will try to switch beater on to correct condition	High Motor Amperage. Occurs when system detects motor amperage is above programmed limit	Disconnect unit main power and restore	<ol style="list-style-type: none"> 1. Product too cold/low overrun 2. Loose wire Connection 3. Open starter coil 4. Faulty capacitor (1 ph. Only) 5. Faulty beater motor 	<ol style="list-style-type: none"> 1. Adjust product temperature/Use smaller mix feed opening. 2. Contact your Electro Freeze distributor for service.

ELECTRO FREEZE®

REPLACEMENT PARTS MANUAL with ILLUSTRATIONS

QUALITY PARTS
PROTECT
YOUR
EQUIPMENT

**SOFT SERVE
TWIST MODEL
SLX400,
SLX400E, SLX500**

184584-01 6/14/13

**KEEP YOUR FREEZER IN EXCELLENT CONDITION. ALWAYS CONTACT
YOUR ELECTRO FREEZE DISTRIBUTOR FOR REPLACEMENT PARTS.**

Replacement Parts Orders

You must have the serial number of your freezer when ordering parts — parts may differ with a particular serial number of the same model.

Parts are listed using terminology that best fits the function of the part. The illustrations in this section will help you to find the correct part number and description.

Place your parts order through your local authorized Electro Freeze Distributor.

Name: _____

Address: _____

Phone: _____

If you require any further assistance, contact H. C. Duke & Son, LLC *Electro Freeze* as follows:



Phone: (309) 755-4553
(800) 755-4545

FAX: (309) 755-9858

E-mail: service@electrofreeze.com

Table of Contents

PART II

ILLUSTRATIONS

Figure 1 Head Assembly	1
Figure 2 SLX400 Beater Shaft Assembly	2
Figure 3 SLX500 Beater Shaft Assembly	3
Figure 4 Mix Feed Tube Assembly	4
Figure 5 Contactor Box	5
Figure 6 Capacitor Box	5
Figure 7 Control Center	6
Figure 8 Switch Assembly	7
Figure 9 Panel View	8
Figure 10 ... Assembly View	10

OTHER LISTS and INFORMATION

Accessories	12
O-Ring Chart	13

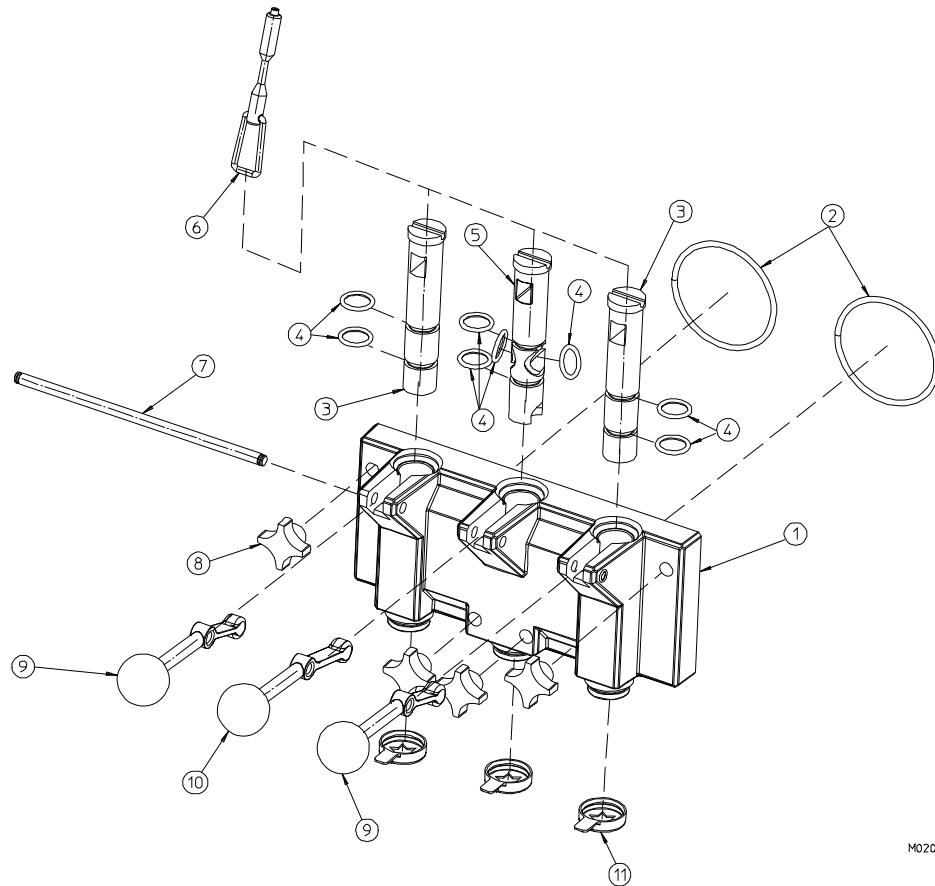

M02039

Figure 1 Head Assembly

Item	Part No.	Description
*	HC121186	Head-Assy. Dispense ADA
1	HC196295	Head-Dispensed Molded (Head only)(Black)
2	HC160583	O-ring (Head)
3	HC137174	Plunger-Side Self Dispense
4	HC160501	O-ring (Plunger)
5	HC138009	Plunger-Dispense Center
6	HC113426	Push Rod-Assy. Plunger Switch
7	HC141311	Pin-Handle
7A	HC160581	O-ring (not shown)
8	HC162625	Knob-Hand
9	HC120864	Handle-Assy Dispense ADA (Side)
	HC162629	Knob-Ball 3/8-16 THD Black
10	HC120865	Handle-Assy Dispense Center ADA
	HC162629	Knob-Ball 3/8-16 THD Black
11	HC196192	Nozzle-Serrated Six Point

* Includes all items above except #6 and #8.

Not Shown:

- [HC114341-05](#) Stud-Assy. Cylinder 3-5/16" (Bottom)
- [HC114341-08](#) Stud-Assy. Cylinder 2-5/16" (Top)
- [HC116410](#) Switch-Dispense Head Kit

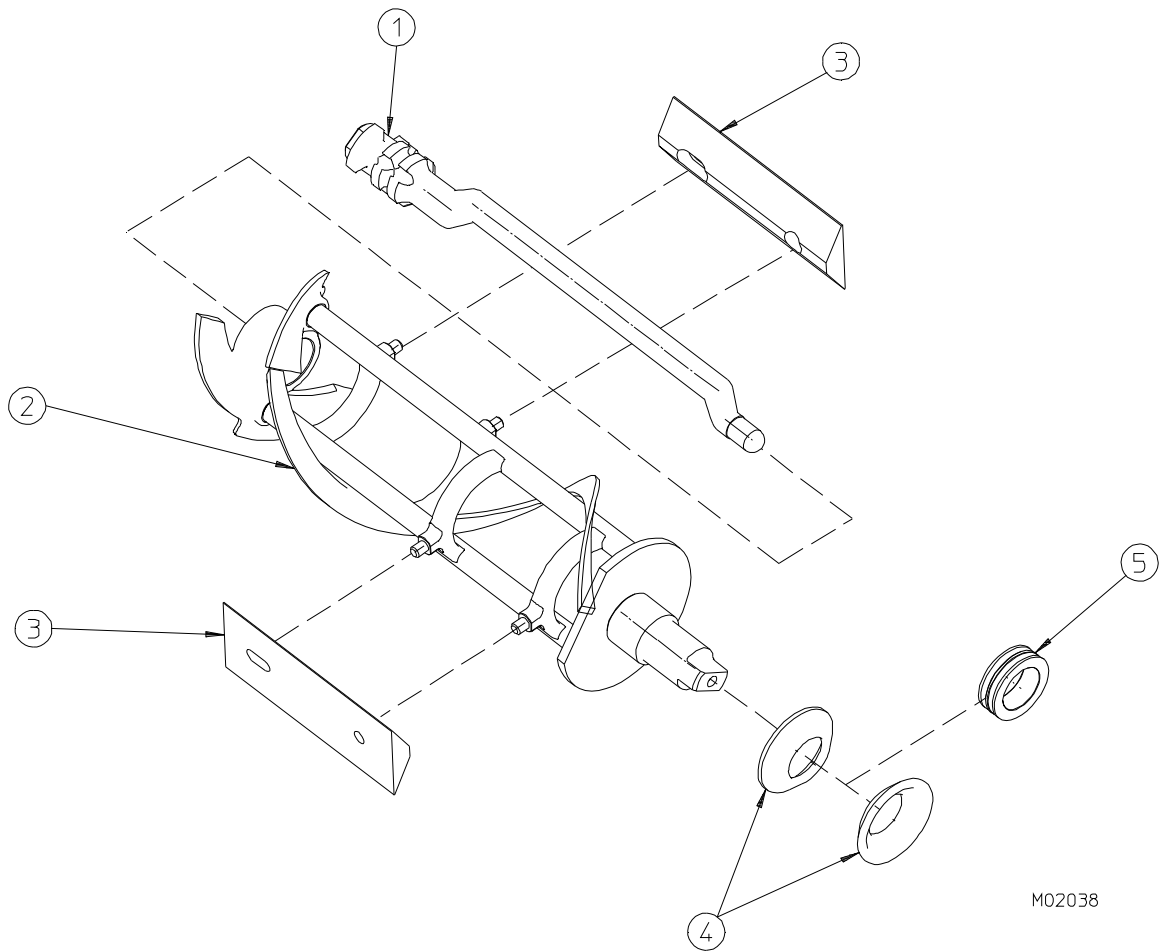

M02038

Figure 2 SLX400 Beater Shaft Assembly

Item	Part No.	Description
1	HC196297	Bar-Breaker
2	HC121139	Shaft- Assy. Beater
3	HC141236	Blade-Scraper (Non-Rev)
4*	HC160557	Seal-Beater Shaft
5*	HC137593	Washer-Double Shaft Seal

* Can be ordered together
[HC115525](#) Seal-Assy. Shaft Double

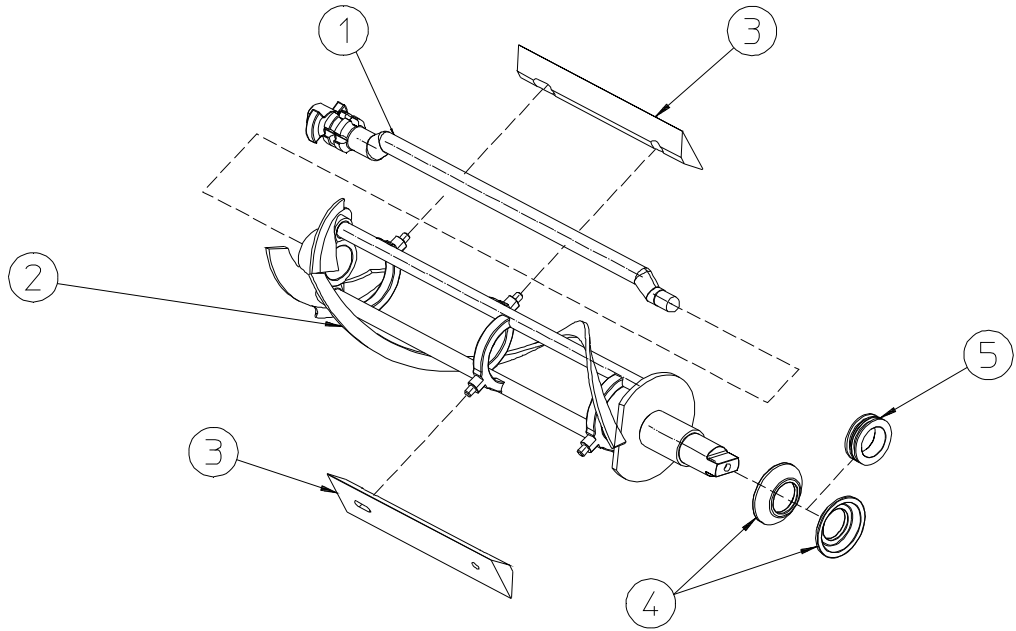

M02040

Figure 3 SLX500 Beater Shaft Assembly

Item	Part No.	Description
1	HC196301	Bar-Breaker
2	HC120866	Shaft- Assy. Beater
3	HC141009	Blade-Scraper (Non-Rev)
4*	HC160557	Seal-Beater Shaft
5*	HC137593	Washer-Double Shaft Seal

* Can be ordered together
[HC115525](#) Seal-Assy. Shaft Double

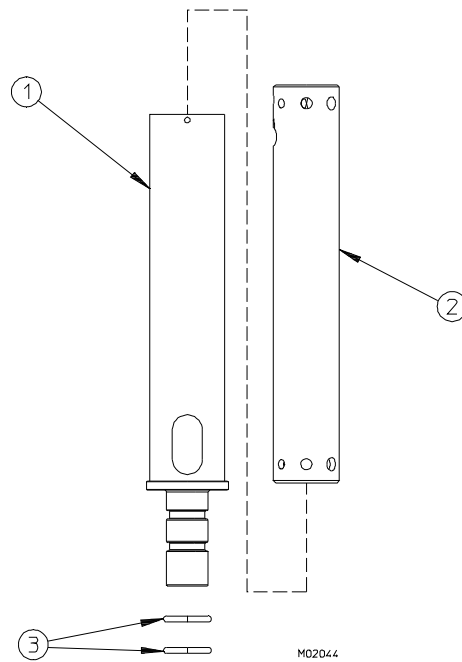

Figure 4 Mix Feed Tube Assembly

Item	Part No.	Description
*	HC121252-01	Tube- Assy Mix Feed Complete Short (SLX400)
*	HC121252	Tube- Assy Mix Feed Complete Long (SLX500)
1	HC121251-01	Tube-Rear Mix Feed Short (SLX400)
or	HC121251	Tube-Rear Mix Feed Long (SLX500)
2	HC141334-01	Sleeve-Rear Mix Feed Short (SLX400)
or	HC141334	Sleeve-Rear Mix Feed Long (SLX500)
3	HC160502	O-ring

Includes items 1 through 3.

Figure 5 Contactor Box

Item	Part No.	Description
1	IC574100325	Transformer 1~ 75VA TA-1-81142 Standard
2	HC150076	Contacteur-3P 25A 24V Coil BF25 (Compressor/Fan)
3	HC150076	Contacteur-3P 25A 24V Coil BF25 (Beater Motor)
4	HC151704	Board-Current Sense SLX

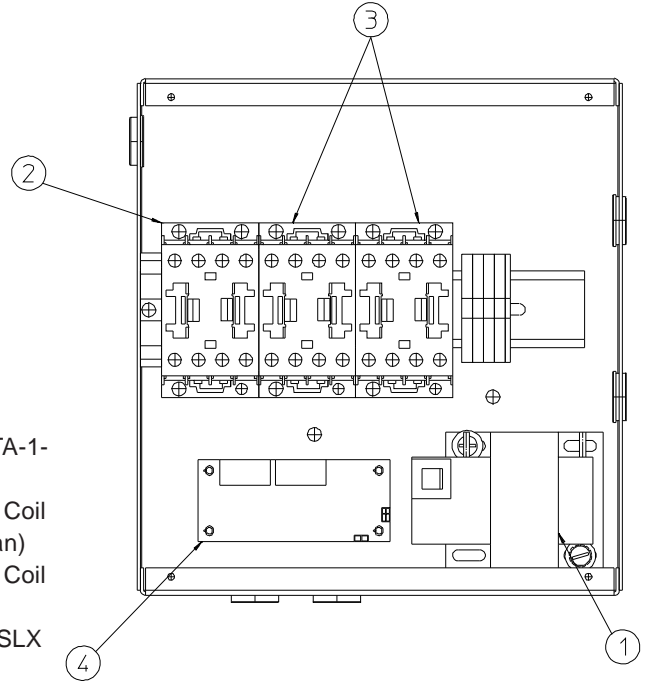
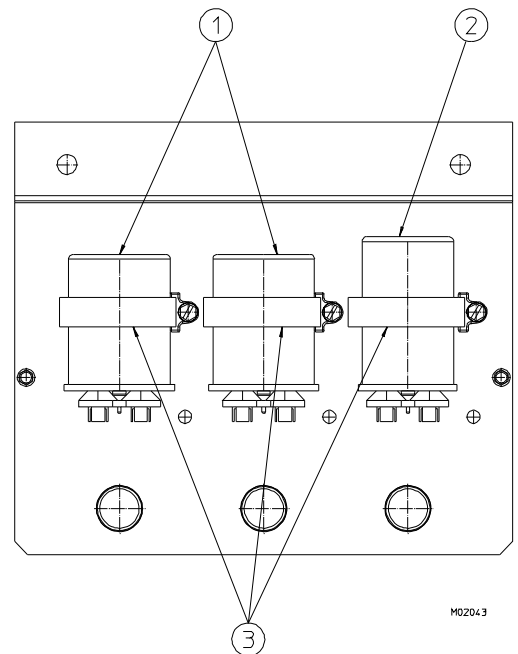

Figure 6 Capacitor Box

Item	Part No.	Description
1	HC150318	Capacitor-Run (SLX500) (Beater Motor)
2	HC150491	Capacitor-Run (SLX500) (Compressor)
or	HC150244	Capacitor-Run (SLX400 Series) (Compressor)
3	HC160772	Clamp-Hose 1-5/16 - 2/14

Note: Model SLX400 Series beater motor capacitors are located on the motors.



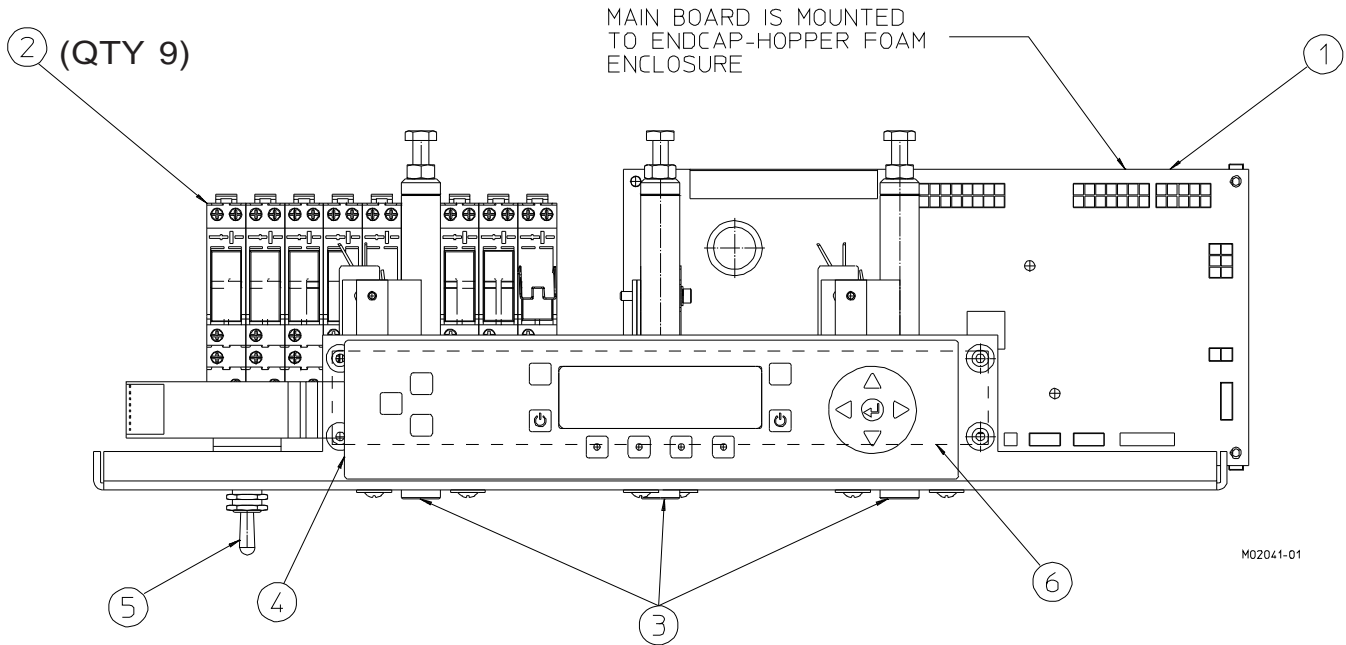
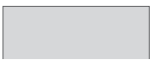
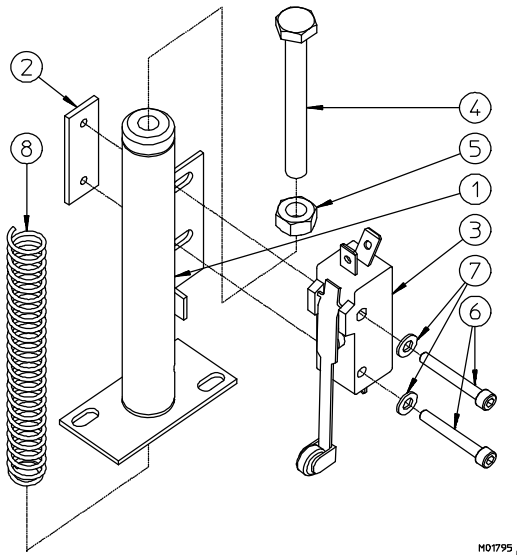

Figure 7 Control Center

Item	Part No.	Description
1	HC151701	Board-PC Main
2	HC150078	Relay-Miniature SPDT 12VDC Coil
2A	HC150165	Socket-Miniature Relay SPDT
2B	HC150166	Clip-Miniature Relay Retaining
3	HC118095	Switch-Assy Plunger Side LH (see Figure 8)
4	HC150993	Membrane (Switch Covering)
5	HC150046	Switch-Toggle 3PST 2HP
6	HC150994	Board-PCB UI



H01795

Figure 8 Switch Assembly

Item	Part No.	Description
*	HC118095	Switch-Assy. Plunger Side LH (Complete)
1	HC114174	Guide-Assy. Push Rod
2	HC140701	Plate-Switch
3	HC150477	Switch-Roller Actuator SPDT
4	HC159912	Screw-HXHM 1/4-20 x 2-1/4 ZN
5	HC160104	Nut-HEX 1/4-20 ZN
6	HC160381	Screw-SKHC #6-32 x 1 BKOX
7	HC160393	Washer-Flat #6 Brass
8	HC162323	Spring-Compression MW ZN

*Includes items 1 through 8.

Figure 9 Panel View (Sheet 1 of 2)

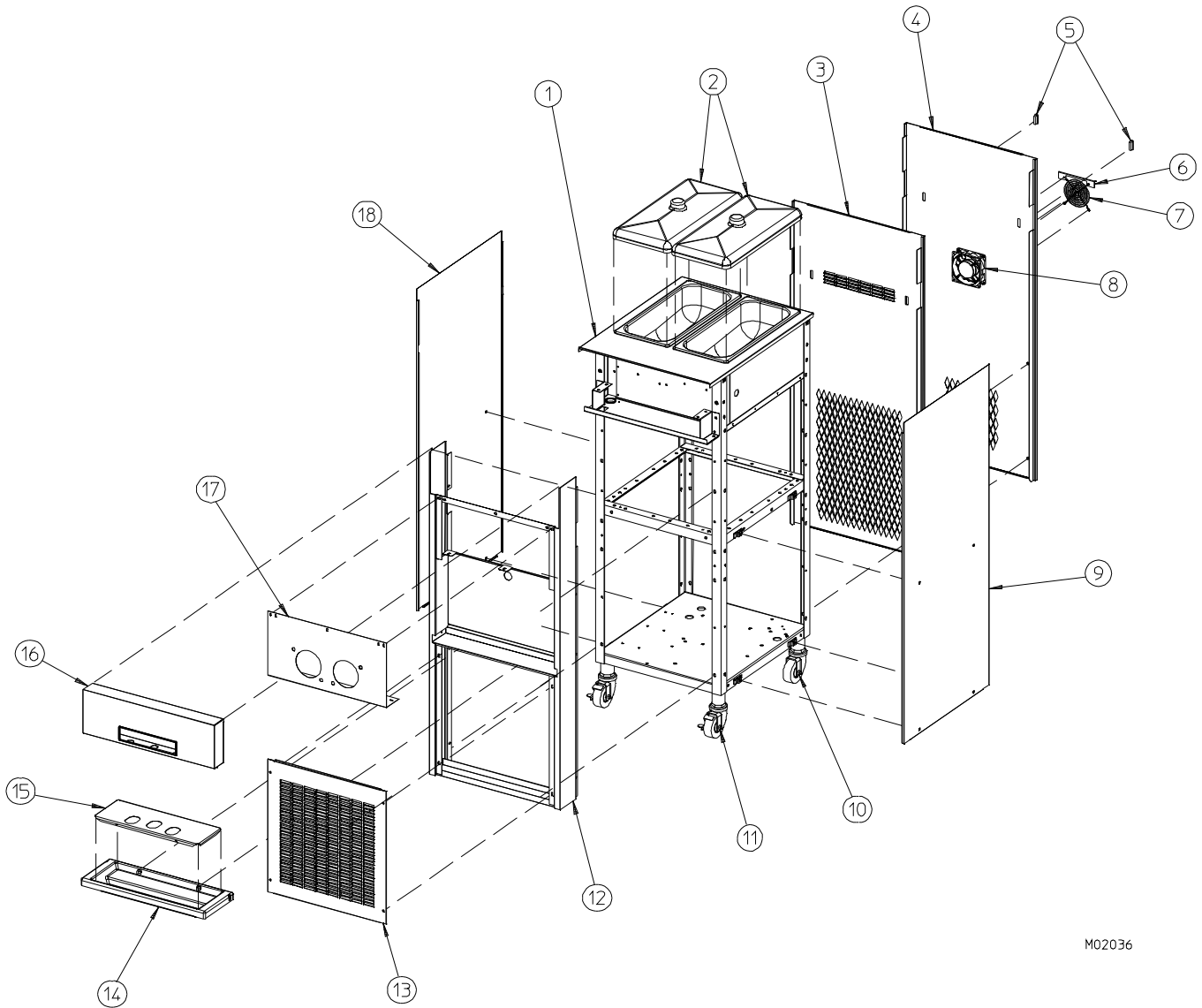

M02036

Hardware for Panels				
Panel	Screw	Nut-Speed	Spacer	Nut-Speed on Frame
Dispense	HC160076	HC159132	n/a	n/a
Front	HC160076	HC159132	n/a	HC159067
Rear	HC160048	HC160117	n/a	n/a
Side	HC159219	HC160114	HC138456	n/a
Trimstrip	HC160076	n/a	n/a	n/a
n/a – Not Applicable				

Figure 9 Panel View (Sheet 2 of 2)

Item	Part No.	Description
1	HC121132	Panel-Assy. Hopper and Top (SLX400 Series)
or	HC121179	Panel-Assy. Hopper and Top (SLX500)
2	HC196298	Cover-Hopper
3	HC121191	Panel-Assy. Rear A/C (Air Cooled)
4	HC121250	Panel-Rear W/C (Water Cooled)
5	HC150992	Light-Indicator 14VDC
6	HC138221	Cap-Drip Fan Port (Water Cooled)
7	HC151095	Guard-Finger (Water Cooled)
8	HC151094	Fan-Axial 19W (Water Cooled)
9	HC141307	Panel-Side
10	HC162106	Caster-1-1/4 St. PT w/o Brake
10A	HC150736	Nut-Lock Conduit 1-1/4 (for Casters)
11	HC162105	Caster-1-1/4 St. PT w/Brake
11A	HC150736	Nut-Lock Conduit 1-1/4 (for Casters)
12	HC121190	Panel-Assy. Front
12A	HC199016	Grommet-Rubber 5/8 ID (Not shown)
13	HC140941	Panel-Front Louvered
14	HC196270	Tray-Drip 22 in Black
15	HC120778	Insert-Assy. Drip Tray
16	HC120855-01	Trimstrip-Assy. SST
17	HC141294	Panel-Dispense
18	HC141307	Panel-Side

Not Shown:

HC150605 Cord-Molded Plug 20A, 250V (Model SLX400E Only):

Panel Decals & Labels	
Part No.	Description
HC164034	Beater Installation
HC165025-02	Beater Warning Black
HC165025-01	Beater Warning Twist
HC164221	Cleaning Instruction
HC165126	Panel Removal
HC165188-08	Trimstrip EF Logo 22"
HC169053	Ventilation 6" RR

Figure 10 Assembly View

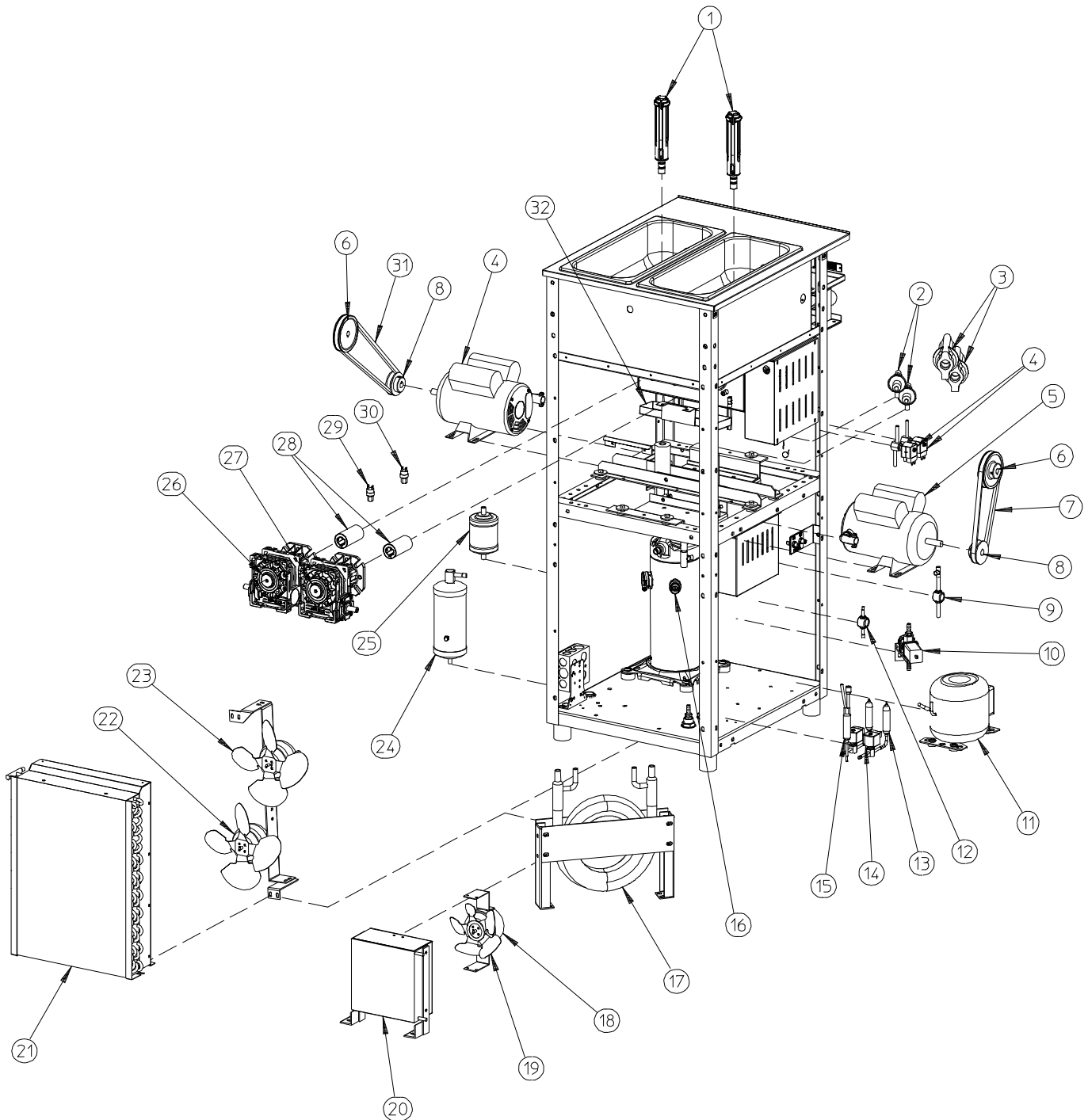

M02037

Accessories

Part No.	Description
HC196103	Bottle-Wash 500 ml
HC158009	Brush-4 in. w/o handle (Handle p/n HC158012)
HC158003	Brush-7/16 & 1-1/8 Double End
HC158077	Brush-9/16 in w/36 in. handle
HC162105	Caster-1-1/4 ST PT w/brake
HC162106	Caster-1-1/4 ST PT w/o brake
HC184294	Chart-O-ring EF Gravity SS (Laminated)
HC196298	Cover-Hopper
HC158012	Handle-Brush Fiberglass (Brush p/n HC158009)
HC158000A	Lubricant-Petro-Gel 4 oz. tube
HC196185	Nozzle-Serrated Six Point
HC150736	Nut-Lock Conduit 1-1/4 (Casters)
HC158013	Sanitizer-Stera Sheen (Sample)
HC158014	Sanitizer-Stera Sheen (Per case/4 jars)
HC158014A	Sanitizer-Stera Sheen (Per 4 lb. jar)
HC158049	Scale-Overrun
HC184586	Sheet-Clean & Saniitize SLX400/SLX500
HC169374	Tool-O-ring Removal
HC196270	Tray-Drip 22 in. Black

HC184294

GRAVITY SOFT SERVE DISPENSING HEAD

REV 01

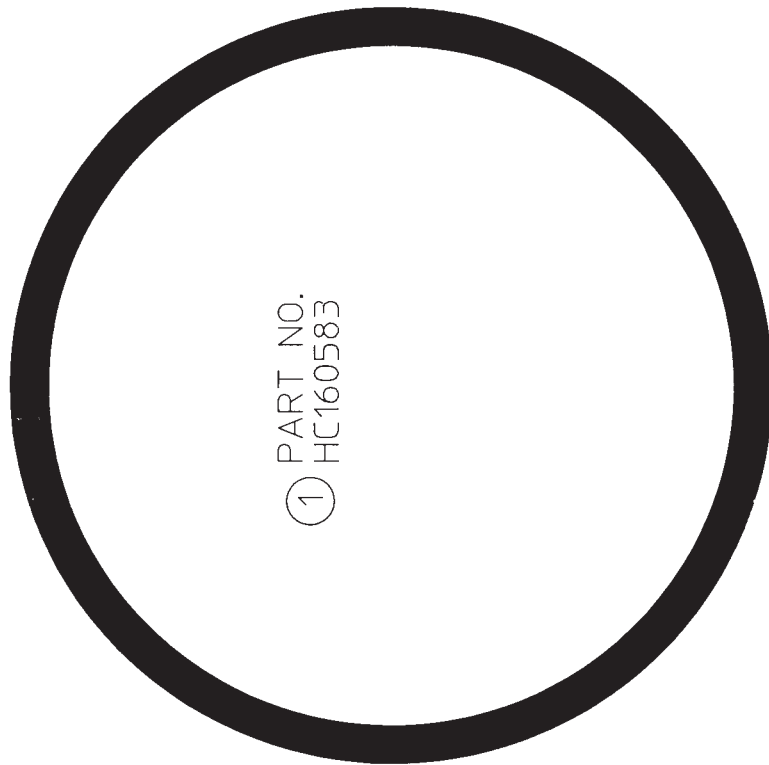

① PART NO.
HC160583

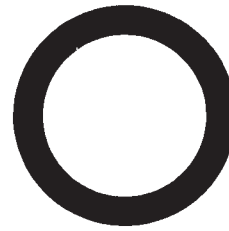

② PART NO.
HC160501



③ PART NO.
HC160581

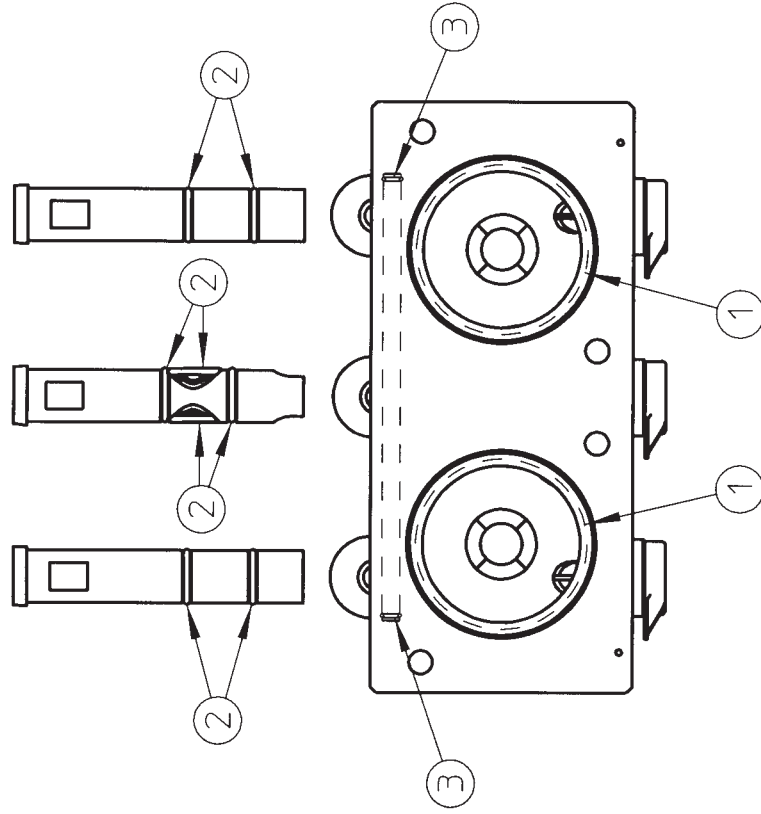

O-RING CHART

PH. NO. 309-755-4553

H.C. DUKE & SON, LLC

MIX FEED REGULATOR



① PART NO.
HC160502

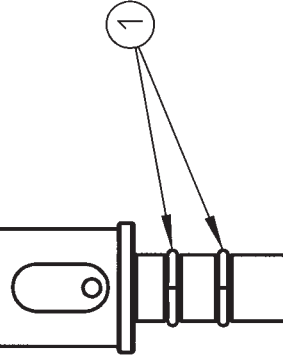

O-RING CHART