

SERVICE MANUAL

BLAST CHILLER FREEZER RANGE 30 50 70

2020

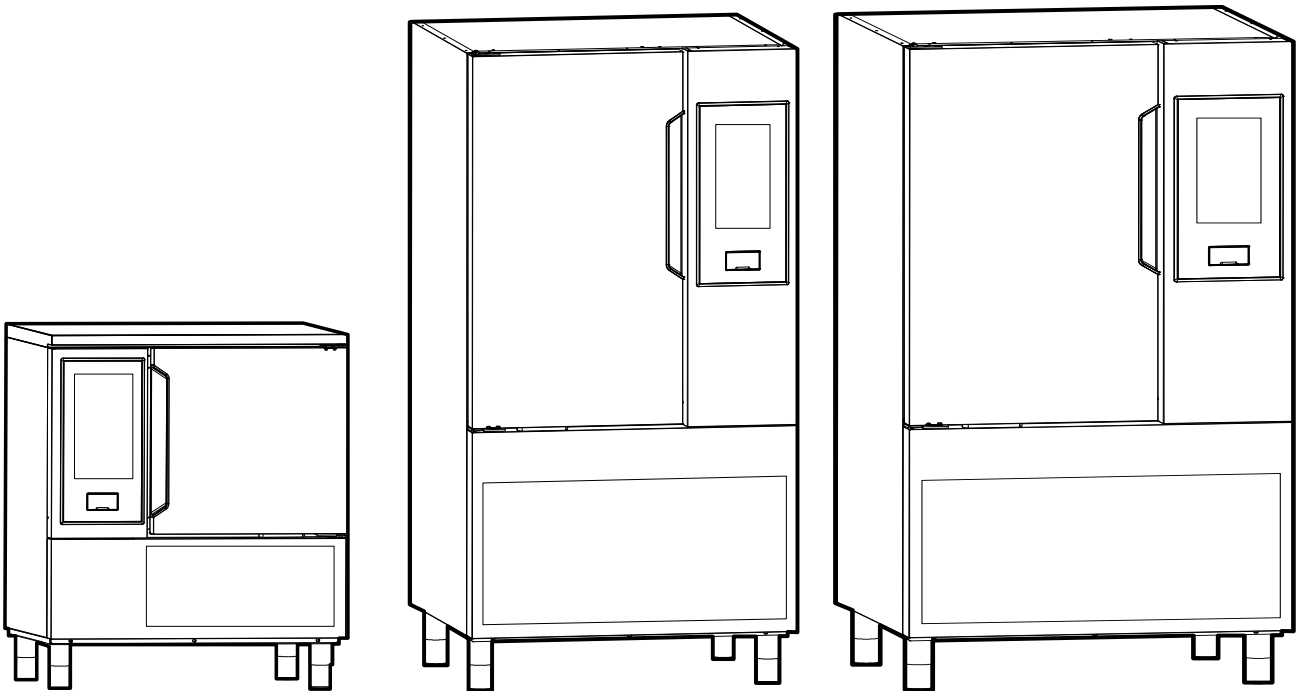



Document made by Product Care – Technical Training & Service – Vallenoncello PN/Italy

All the images and information of this document are property of ©Electrolux Professional Spa. This document and all of its contents cannot be copied or used, in part or entirely without the written authorization of Electrolux Professional Spa.

©Electrolux Professional Spa.



REVISIONS UPDATE:

EDITION	DESCRIPTION	DATE
1.0.0	First publication	FEBRUARY. 2019
1.0.1	Modification pag 3.12.13.14	JUNE 2019
1.0.2	Modification pag 12.26.35.40.63.65.71.101.121	JULY 2019
1.0.3	Modification pag 17.38.63.109.110.111.132.133.134	JULY 2019
1.0.4	Modification pag 4.19.22.23.68.81	SEPTEMBER 2019
1.0.5	Modification pag 1.54	OCTOBER 2019
1.0.6	Modification pag 1.67 to 74.160	FEBBRARY 2020

Foreward



The service manual (here in after Manual) provides the engineer with information necessary for correct and safe use of the machine (or “appliance”).

The following must not be considered a long and exacting list of warnings, but rather a set of instructions suitable for improving machine performance in every respect and, above all, preventing injury to persons and animals and damage to property due to improper operating procedures.

All persons involved in machine transport, installation, commissioning, use and maintenance, repair and disassembly must consult and carefully read this manual before carrying out the various operations, in order to avoid wrong and improper actions that could compromise the machine's integrity or endanger people.

If, after reading this manual, there are still doubts regarding machine use, do not hesitate to contact the Manufacturer or the Customer Care to receive prompt and precise assistance for better operation and maximum efficiency of the machine. During all stages of machine assessment, always respect the current regulations on safety, work hygiene and environmental protection. It is the user's responsibility to make sure the machine is started and operated only in optimum conditions of safety for people, animals and property.

IMPORTANT

- The manufacturer declines any liability for operations carried out on the appliance without respecting the instructions given in this manual.
- The manufacturer reserves the right to modify the appliances presented in this publication without notice.
- No part of this manual may be reproduced without the consent of the manufacturer.
- This manual is available in digital format by:
 - contacting the dealer or reference customer care;
 - downloading the latest and up to date manual/technical bulletin(s) on the web site;: www.electrolux.com/professional.

The manual must always be part of the documentation available when servicing the machine.



MODELS COVERED BY THE SERVICE MANUAL

This manual is relative to the following list of appliances.

MODEL TYPE	30 KG BUILT IN	50 KG BUILT IN	70 KG BUILT IN	30 KG REMOTE	50 KG REMOTE	70 KG REMOTE
DESCRIPTION	6 GN 1/1 PASTRY 60X40	10 GN 1/1 PASTRY 60X40	10 GN 2/1 PASTRY 60X40	6 GN 1/1 PASTRY 60X40	10 GN 1/1 PASTRY 60X40	10 GN 2/1 PASTRY 60X40
VOLTAGE	380/415V 3~ 50HZ	380/415V 3~ 50HZ	380/415V 3~ 50HZ	380/415V 3~ 50HZ	380/415V 3~ 50HZ	380/415V 3~ 50HZ
GAS REF.	R452 R404a	R452 R404a	R452 R404a	Change term.valve	Change term.valve	Change term.valve
CLIMATC CLASS	5	5	5	5	5	5
AMPERE	6.3	8.4	11.5	4.4	8.6	8.6
REFR. QUANTITY g.	1150	2000	3000	/	/	/
IP PROTECTION	X4	X4	X4	X4	X4	X4

MODEL TYPE USA	30 KG BUILT IN	50 KG BUILT IN	70 KG BUILT IN	30 KG REMOTE	50 KG REMOTE	70 KG REMOTE
DESCRIPTION	6 GN 1/1 PASTRY 60X40	10 GN 1/1 PASTRY 60X40	10 GN 2/1 PASTRY 60X40	6 GN 1/1 PASTRY 60X40	10 GN 1/1 PASTRY 60X40	10 GN 2/1 PASTRY 60X40
VOLTAGE	208V 3~ 60HZ	208V 3~ 60HZ	208V 3~ 60HZ	208V 3~ 60HZ	208V 3~ 60HZ	208V 3~ 60HZ
GAS REF.	R448A	R448A	R448A	R448A	R448A	R448A
CLIMATC CLASS	5	5	5	5	5	5
AMPERE	MCA 15 MOP 35	MCA 24 MOP 60	MCA 31 MOP 80	/	/	/
KW	2.7	4.5	5.5			
REFR. QUANTITY g.	1150	2000	3000	/	/	/
IP PROTECTION	X4	X4	X4	X4	X4	X4



INDEX

1. GENERAL INFORMATION	10
1.1 GENERAL INFORMATION.....	10
1.2 SAFETY INFORMATION/PRECAUTIONS.....	11
1.3 PERSONAL PROTECTION EQUIPMENT	12
1.4 GENERAL SAFETY INFORMATION.....	13
1.4.1 Residual Risks	13
1.5 SAFETY SIGNS TO BE PLACED NEAR THE MACHINE AREA.....	15
1.6 DATA PLATE (IDENTIFICATION STICKER) / QR-Code sticker.....	16
1.6.1 Serial Number (Production Date)	17
1.7 TECHNICAL DATA AND DRAWINGS WITH MEASUREMENTS.....	18
1.8 GENERAL REFERENCE TO APPLICABLE PRODUCT CERTIFICATIONS	19
1.9 EQUIPMENT MODULES AND INTERACTIONS	19
1.9.1 Blast chiller /freezer 50 kg 10 gn 1/1 and 70 kg 10 gn 2/1	19
1.9.2 Electrical schema interactions 50_70 kg Europa	20
1.9.3 Electrical schema interactions 50_70 kg USA.....	21
1.9.4 Blast chiller /freezer 30kg 6 gn 1/1	22
1.9.5 Electrical schema interactions 30 kg Europa	23
1.9.6 Electrical schema interactions 30 kg USA.....	24
1.10 DEFINITIONS/GLOSSARY.....	25
2. INSTALLATION AND COMMISSIONING	26
2.1 INSTALLATION.....	26
2.2 PRE-CONNECTION PREPARATIONS	26
2.3 LIST OF POSSIBLE INSTALLATION SOLUTIONS	27
2.4 ROOM REQUIREMENTS	27
2.5 REFRIGERATION POWER OF REMOTE UNIT	27
2.5.1 Refrigeration power table	27
2.6 CONNECTION REMOTE UNIT	28
2.6.1 Technical Instructions / Installation Precautions	28
2.6.2 General Information.....	28
2.6.3 Basic Installation – Overview.....	28
2.6.4 Installation Steps	29
2.6.5 System Evacuation	30
2.6.6 Procedures for Refrigerant Charge	30
2.6.7 Piping.....	31
2.6.8 Basic Accessories of a Cooling System.....	32



- 2.6.9 Expansion Valve 34
- 2.6.10 Setting the Expansion valve 34
- 2.6.11 Correct position of the thermostatic sensor 34
- 2.6.12 Identification of the thermostatic valve 35
- 2.6.13 Charge MOP 36
- 2.6.14 Quantity of refrigerant to charge 36
- 2.6.15 Electrical connection 37
 - 2.6.15.1 Electrical box drawing on remote unit 37
 - 2.6.15.2 Electrical box in the BCF: IE. Of clamp connections 38
- 2.7 UNPACKING AND POSITIONING THE EQUIPMENT 39
- 2.8 COMMISSIONING 40
 - 2.8.1 Power connection on bcf 380/400V 40
 - 2.8.2 Power connection on bcf 208V (USA) 40
 - 2.8.3 Description Main Display 41
 - 2.8.3.1 Icon description, Message of Dialogues 42
 - 2.8.4 Softwar update 44
 - 2.8.5 Programming file 45
 - 2.8.5.1 How to update: 45
 - 2.8.6 Programming parameters 46
 - 2.8.6.1 How to update: 46
 - 2.8.7 Pnc & ser upload (pncserial.json) 47
 - 2.8.7.1 How to update pnc & ser (pncserial.json): 47
 - 2.8.7.2 How to install update pnc & ser (pncserial.json): 50
 - 2.8.8 Usb data transfer 52
 - 2.8.8.1 Users management lite 52
 - 2.8.8.2 What follows is a diagram to show menu navigation 52
 - 2.8.8.3 Select types 53
 - 2.8.8.4 Select type 53
 - 2.8.8.5 Select file 54
 - 2.8.8.6 Select file or add new file 54
 - 2.8.8.7 Enter file name 55
 - 2.8.8.8 Select Items 55
 - 2.8.8.9 Confirm 56
 - 2.8.8.10 Replace or add items 56
 - 2.8.8.11 Skip, Duplicate, Add 57
 - 2.8.8.12 Enter item name 57
 - 2.8.8.13 Types list for service: 58
 - 2.8.8.14 File names 58
 - 2.8.8.15 Item names 58
 - 2.8.8.16 Errors and Warnings: 58
 - 2.8.9 How to access to service area 60
 - 2.8.9.1 How to show the “data monitor” 61
 - 2.8.9.2 How to exit from “data monitor” and “bypass” 61
 - 2.8.9.3 How to enter in “bypass” 61
 - 2.8.9.4 How to upload the pnc and serial number 61
 - 2.8.9.5 How to upload the parameter and interogation 61



2.8.9.6 Service ambiente explanation	62
2.9 WIZARD	69
2.9.1 Installation wizard check.....	69
2.9.2 Manual Test Wizard.....	77
2.9.2.1 Start manual wizard.....	77
3. USE OF APPLIANCE	80
3.1 OPERATING INSTRUCTIONS	80
3.2 PREVENTIVE MAINTENANCE PLAN (FOR SERVICE): OPERATION FREQUENCY	80
4. DETAILED APPLIANCE AND COMPONENTS DESCRIPTION/FUNCTIONING	81
4.1 MAIN BOARD “PETRA”	81
4.1.1 Functionality.....	81
4.2 USER INTERFACE “TOUCH”	82
4.2.1 Functionality touch panel.....	82
4.2.2 PMH power supply 100-240 Vac to 12V dc.....	83
4.3 SEMI-ERMETIC COMPRESSOR.....	84
4.3.1 Over view.....	84
4.3.2 Expected use of the unit	84
4.3.3 What follows is forbidden:.....	84
4.3.4 Compressor identification	84
4.3.5 Airing of the installation room	84
4.3.6 Pipes Connections.....	85
4.3.7 Table of pipe connection of <i>Dorin</i> compressor.....	86
4.3.8 Electrical connections.....	86
4.3.9 Protection System	87
4.3.10 Commissioning: Preliminary Works.....	87
4.3.11 Compressors Replacement.....	88
4.3.12 Compressor Disassembly.....	88
4.3.13 Number of starts	88
4.3.14 Rotalock Valves	89
4.3.15 Crankcase heater installations	90
4.3.16 Electrical Connection Of The Compressor On The Unit	91
4.3.17 Evaporator Fan	92
4.3.17.1 Functionality fan	92
4.3.17.2 Electrical Connections Fan	93
4.3.18 Probe’s.....	94
4.3.18.1 Probe’s feature	94
4.3.18.2 Electrical Connections Probes	94
4.3.18.3 Probe functions	95
4.3.19 Food Probe	95
4.3.19.1 Functionality	95



4.3.19.2 Electrical Connections Food Probes	98
4.3.20 Heater Evaporator	99
4.3.20.1 Functionality	99
4.3.20.2 Electrical Connections Evaporator Heater	99
4.3.21 Test Digital I/O: Step By Step Digital Operable Components Testing	100
4.3.22 Identify rapid“test cycles and components”	100
5. TROUBLESHOOTING.....	102
5.1 TECHNICIAN TROUBLESHOOTING	102
6. SERVICING THE APPLIANCE	108
6.1 LIST OF NEEDED TOOLS	108
6.1.1 Ordinary Tools	108
6.1.2 Special Tools: List, Description And Spare Part Code Per Each Special Tool	108
6.2 IMPORTANT PROCEDURES FOR INSTALLATION	109
6.2.1 Storage of components	109
6.2.2 Cleaning the pipes.....	109
6.2.3 Installation of refrigeration system components	109
6.3 REPLACING EQUIPMENT COMPONENTS	110
6.3.1 Disassembly/Reassemble Of Components Range 50_70 Kg.....	110
6.3.1.1 Accessing the components on the back side of the appliance	110
6.3.1.2 Rack supports	110
6.3.1.3 Cell probe (blue).....	111
6.3.1.4 Evaporator probe (grey).....	112
6.3.1.5 Food probe	114
6.3.1.6 Condenser probe (black).....	115
6.3.1.7 Outevaporator probe (green)	115
6.3.1.8 Thermostat	116
6.3.1.9 Evaporator fan.....	116
6.3.1.10 Heating element	118
6.3.1.11 Comand Panel.....	118
6.3.1.12 Control Panel.....	119
6.3.1.13 Frame heating element cable.....	119
6.3.1.14 Evaporator	120
6.3.1.15 Electrical box	122
6.3.1.16 Compressor.....	123
6.3.1.17 Solenoid valve	124
6.3.1.18 Finned Coil Condenser	125
6.3.1.19 Condenser fan.....	127
6.3.1.20 Tanic receiver.....	127
6.3.1.21 Dehidrator Filter.....	127
6.3.1.22 Door.....	128
6.3.1.23 Door gasket.....	128
6.3.1.24 Door switch.....	128
6.3.1.25 Thermostatic valve	129
6.3.1.26 Access display and replacement of mambrane sticker	130
6.3.2 Disassembly/Reassemble Of Components Range 30 Kg.....	133
6.3.2.1 Accessing the components on the back side of the appliance	133



6.3.2.2 Rack supports	134
6.3.2.3 Cell probe (blue).....	135
6.3.2.4 Evaporator probe (grey).....	136
6.3.2.5 Food probe	137
6.3.2.6 Condenser probe (black).....	138
6.3.2.7 Out evaporator probe (green)	138
6.3.2.8 Thermostat	139
6.3.2.9 Evaporator fan.....	139
6.3.2.10 Heating element	141
6.3.2.11 Command Panel.....	141
6.3.2.12 Control Panel.....	142
6.3.2.13 Frame heating element cable.....	142
6.3.2.14 Evaporator	143
6.3.2.15 Electrical box	145
6.3.2.16 Compressor.....	146
6.3.2.17 Solenoid valve	147
6.3.2.18 Finned Coil Condenser	148
6.3.2.19 Condenser fan.....	150
6.3.2.20 Tanic receiver.....	150
6.3.2.21 Dehydrator Filter.....	150
6.3.2.22 Door.....	151
6.3.2.23 Door gasket.....	151
6.3.2.24 Door switch.....	151
6.3.2.25 Thermostatic valve	152
6.3.2.26 Access display and replacement of mambrane sticker.....	153
6.3.3 Preventive Maintenance Plan.....	156
6.3.3.1 Refert to document “Check list preventive maintenance	156
7. RELATED DOCUMENTS	156
7.1 EXPLODED VIEW	156
7.1.1 List Of The Vital and Wear&Tear Parts	156
7.1.2 List Of Available Accessories	156
7.1.3 List Of Consumables	156
7.1.4 List Of Spares Wear And Tear	156
7.2 ELECTRICAL WIRING DIAGRAM.....	156
7.3 PARAMETERS LIST:.....	157



1. GENERAL INFORMATION

1.1 GENERAL INFORMATION

To ensure safe use of the machine and a proper understanding of the manual it is necessary to be familiar with the terms and typographical conventions used in the documentation. The following symbols are used in the manual to indicate and identify the various types of hazards:

 **WARNING**
Danger for the health and safety of operators.

 **WARNING**
Danger of electrocution - dangerous voltage.

 **CAUTION**
Risk of damage to the machine or the product.

 **WARNING**
Danger of magnetic fields.

 **IMPORTANT**
Important instructions or information on the product

 Read the instructions before using the appliance

 Clarifications and explanations

- Only specialised personnel are authorised to operate on the machine.
- This appliance must not be used by minors and adults with limited physical, sensory or mental abilities or without adequate experience and knowledge regarding its use.
 - Do not let children play with the appliance.
 - Keep all packaging and detergents away from children.
 - Cleaning and user maintenance shall not be made by children without supervision.
- Do not store explosive substances, such as pressurized containers with flammable propellant, in this appliance or close to the appliance
- Do not remove, tamper with or make the machine “CE” marking illegible.
- Refer to the data given on the machine’s data plate “CE” marking for relations with the Manufacturer (e.g. when ordering spare parts, etc.).
- When scrapping the machine, the “CE” marking must be destroyed.







1.2 SAFETY INFORMATION/PRECAUTIONS

- Risks mainly of a mechanical, thermal and electrical nature exist in the machine. Where possible the risks have been neutralised:
 - directly, by means of adequate design solutions.
 - indirectly by using guards, protection and safety devices.
- During maintenance several risks remain, as these could not be eliminated, and must be neutralised by adopting specific measures and precautions.
- Do not carry out any checking, cleaning, repair or maintenance operations on moving parts. Workers must be informed of this prohibition by means of clearly visible signs.
- To guarantee machine efficiency and correct operation, periodical maintenance must be carried out according to the instructions given in this manual.
- Make sure to periodically check correct operation of all the safety devices and the insulation of electrical cables, which must be replaced if damaged.
- Extraordinary machine maintenance operations must only be carried out by specialized Technicians provided with all the appropriate personal protection equipment (safety shoes, gloves, glasses, overalls, etc.), tools, utensils and ancillary means.
- Never operate the machine, removing, modifying or tampering with the guards, protection or safety devices.
- Before carrying out any operation on the machine, always consult the manual which gives the correct procedures and contains important information on safety.



1.3 PERSONAL PROTECTION EQUIPMENT

Summary table of the Personal Protection Equipment (PPE) to be used during the various stages of the machine's service life.X

Stage	Protective garments 	Safety footwear 	Gloves 	Glasses 	Safety helmet 
Transport	—	●	○	—	○
Handling	—	●	○	—	—
Unpacking	—	●	●	—	—
Installation	—	●	● ²	●	—
Normal use	●	●	● ¹	○	—
Adjustments	○	●	○	○	—
Routine cleaning	○	●	● ^{1 or 2}	○	—
Extraordinary cleaning	○	●	● ^{1 or 2}	○	—
Maintenance	○	●	○	○	—
Dismantling	○	●	○	○	—
Scrapping	●	●	●	●	—
Key:					
●	PPE REQUIRED				
○	PPE AVAILABLE OR TO BE USED IF NECESSARY				
—	PPE NOT REQUIRED				

1. During these operations, the worn gloves must be heatproof to protect hands from contact with hot food or hot parts of the appliance and/or when removing hot items from it. Failure to use the personal protection equipment by operators, specialized personnel or users can involve exposure to chemical risk and possible damage to health (depending on the model).
2. During these operations, the worn gloves must be cut-resistant. Failure to use the personal protection equipment by operators, specialized personnel or users can involve exposure to damage to health (depending on the model).



1.4 GENERAL SAFETY INFORMATION

The machines are provided with electric and/or mechanical safety devices for protecting workers and the machine itself. Therefore, the user must not remove or tamper with such devices. The Manufacturer declines any liability for damage due to tampering or their non-use.

Never operate the machine, removing, modifying or tampering with the guards, protection or safety devices.

Do not make any modifications to the parts supplied with the appliance.

Several illustrations in the manual show the machine, or parts of it, without guards or with guards removed. This is purely for explanatory purposes.

Do not use the machine without the guards or with the protection devices deactivated.

Do not remove, tamper with or make illegible the safety, danger and instruction signs and labels on the machine.

Air recirculation must take into account the air necessary for combustion, 2 m³/h/kW of gas power, and also the "well-being" of persons working in the kitchen.

Inadequate ventilation causes asphyxia.

Do not obstruct the ventilation system in the place where this appliance is installed.

Do not obstruct the vents or ducts of this or other appliances.

Place emergency telephone numbers in a visible position.

The measured sound level emitted "A" does not exceed 70 dB ("A").

Turn the appliance off in case of fault or poor operation.

Do not use products (even if diluted) containing chlorine (sodium hypochlorite, hydrochloric or muriatic acid, etc.) to clean the appliance or the floor under it.

Do not use metal tools to clean steel parts (wire brushes or Scotch Brite type scouring pads).

Do not allow oil or grease to come into contact with plastic parts.

Do not allow dirt, fat, food or other residuals to form deposits on the appliance.

Do not spray water or use steam to clean the equipment.

Do not store or use gasoline or other flammable vapours, liquids or items near this or any other appliance.

Do not spray aerosols near this appliance while it is in operation.

Never check for leaks with an open flame.

1.4.1 Residual Risks

The machine has several risks that were not completely eliminated from a design standpoint or with the installation of adequate protection devices. Nevertheless, through this manual the Manufacturer has taken steps to inform operators of such risks, carefully indicating the personal protection equipment to be used by them. Sufficient spaces are provided for during the machine installation stages in order to limit these risks.

To preserve these conditions, the areas around the machine must always be:

Kept free of obstacles (e.g. ladders, tools, containers, boxes, etc.);

Clean and dry;

Well lit.

For the Customer's complete information, the residual risks remaining on the machine are indicated below: such actions are deemed improper and therefore strictly forbidden.

Residual risk	Description of hazardous situation
Slipping or falling	The operator can slip due to water or dirt on the floor
Burns/abrasions (e.g. heating elements)	The operator deliberately or unintentionally touches some components inside the machine without using protective gloves
Electrocution	Contact with live parts during maintenance operations carried out with the electrical panel powered
Tipping of loads	When handling the machine or the packing containing it, using unsuitable lifting systems or accessories or with the unbalanced load

Mechanical safety characteristics, hazards



Mechanical safety characteristics, hazards

The appliance does not have sharp edges or protruding parts. The guards for the moving and live parts are fixed to the cabinet with screws, to prevent accidental access.





Protection devices installed on the machine





The guards on the machine are:

fixed guards (e.g. casings, covers, side panels, etc.), fixed to the machine and/or frame with screws or quick-release connectors that can only be removed or opened with tools.



1.5 SAFETY SIGNS TO BE PLACED NEAR THE MACHINE AREA

Prohibition	Meaning
	Do not remove the safety devices
	Do not use water to extinguish fires (placed on electrical parts)
	Keep the area around the appliance clear and free from combustible materials. Do not keep flammable materials in the vicinity of the appliance
	Install the appliance in a well-ventilated place to avoid the creation of dangerous mixtures of unburnt gases in the same room

Danger	Meaning
	Danger of burns
	Danger of electrocution (shown on electrical parts with indication of voltage)
	Risk of electromagnetic fields
	Access forbidden to wearers of electrical stimulator (pacemakers)

End of use: When the appliance is no longer to be used, make it unusable by removing the mains power supply wiring.



1.6 DATA PLATE (IDENTIFICATION STICKER) / QR-Code sticker

The main identification sticker is located bottom left side and under condenser panel. QR-Code sticker on control panel upper side (visible when opening the door) The meaning of the various information is listed below:

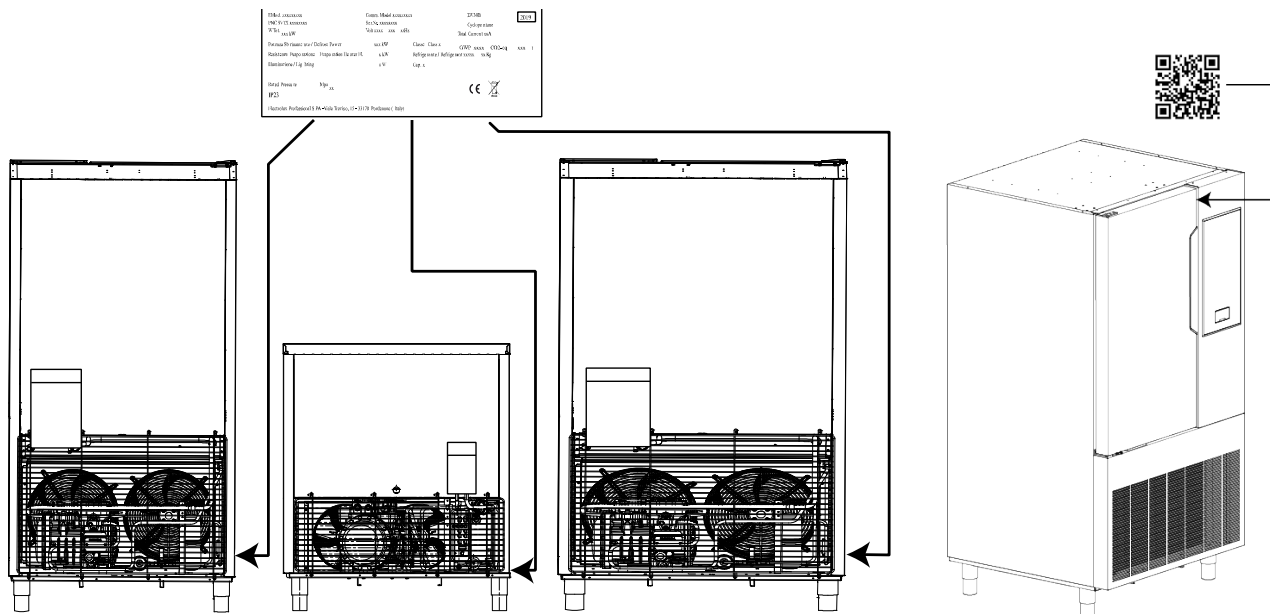

The meaning of the various information is listed below.

Legend of data plate

F.Mod.	Factory model description
Comm.Model	Commercial description
Type Ref.	Refer to model of family (used on spc)
PNC	Production number code
Ser.No	Serial number
V	Power supply voltage / phase
Hz	Power supply frequency
kW	Max. Power input
A	Current absorption
Cyclopentane	Expanding gas used in insulation
IP	Dust and water protection rating
CE	CE marking
L	Logo IMQ/GS
Refrigerant Type	Gas type used
Climatic class	Refer to climatic test
Defrost power	KW
GWP	Global Warning Potential
CO2 eq	Quantity of greenhouse gases
CAP.	Nominal capacity
Electrolux Professional SPA Viale Treviso, 15 33170 Pordenone (Italy)	Manufacturer:



F.Mod. xxxxxxxx PNC 9VTX xxxxxxxx W Tot. xxx kW	Comm.Model xxxxxxxx Ser.Nr. xxxxxxxx Volt xxxx xxx xxHz	LW30B Cyclopentane Total Current xxA	2017
Potenza Sbrinamento / Defrost Power Resistenza Evaporazione / Evaporation Heater El. Illuminazione / Lighting	xxx kW x kW x W	Classe / Class x Refrigerante / Refrigerant xxxxx xx Kg Cap. x	GWP xxxx CO2-eq xxx t
Rated Pressure IP23	Mpaxx	CE	
Electrolux Professional SPA - Viale Treviso, 15 - 33170 Pordenone (Italy)			

1.6.1 Serial Number (Production Date)

The serial is necessary to find the correct spare part or to ask tech. support.

EXAMPLE: Serial Number

8 01 1 0001

18 YEAR
01 WEEK
0001 APPLIANCE
MANUFACTURED



ACTUAL Serial Number

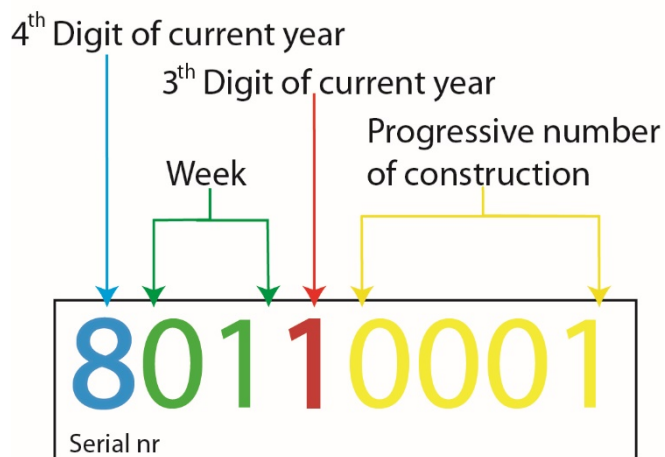



1.7 TECHNICAL DATA AND DRAWINGS WITH MEASUREMENTS

Please, for technical data and overall drawings refer to Installation Manual available on website www.electro-lux.com/professional.

Table reference of dimensional units

Models	Width mm	Deep mm	Max High (adj.level) mm	Min High (adj.level)mm	Whit door open	Weight KG
30KG 6GN 1/1	897	937	1130	1050	1484	169_(rem.155)
50KG 10GN 1/1	895	939	1800	1720	1482	240_(rem.220)
70KG 10GN 2/1	1250	1092	1800	1720	1873.3	320_(rem.290)

The minimum entrance dimension, if you dismantle the door,condenser panel,hinge,door microswitch support top (if necessary) refer to letter Z:

Models	X	Y	Z
30KG 6GN 1/1	726	551	862
50KG 10GN 1/1	726	551	864
70KG 10GN 2/1	1051	662	1017

View by front

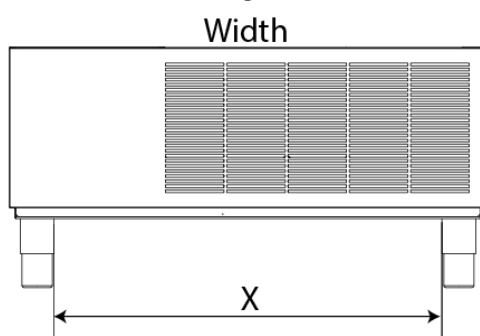

View by side

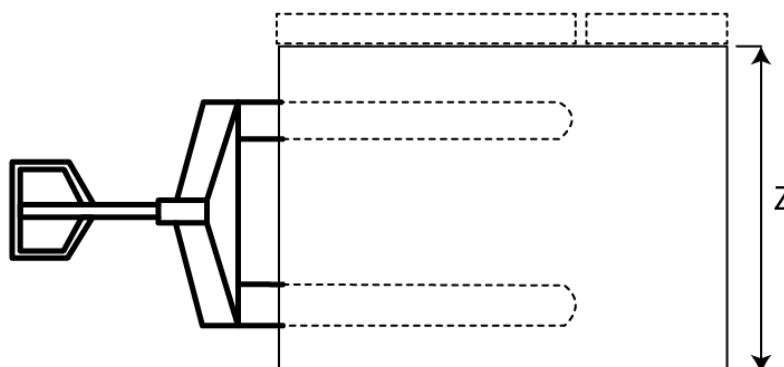
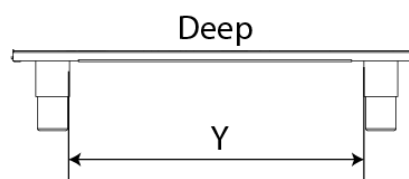



1.8 GENERAL REFERENCE TO APPLICABLE PRODUCT CERTIFICATIONS

Please, for overall certifications refer to Conformity Certificate and Conformity Declaration available on website www.electrolux.com/professional.

1.9 EQUIPMENT MODULES AND INTERACTIONS

1.9.1 Blast chiller /freezer 50 kg 10 gn 1/1 and 70 kg 10 gn 2/1

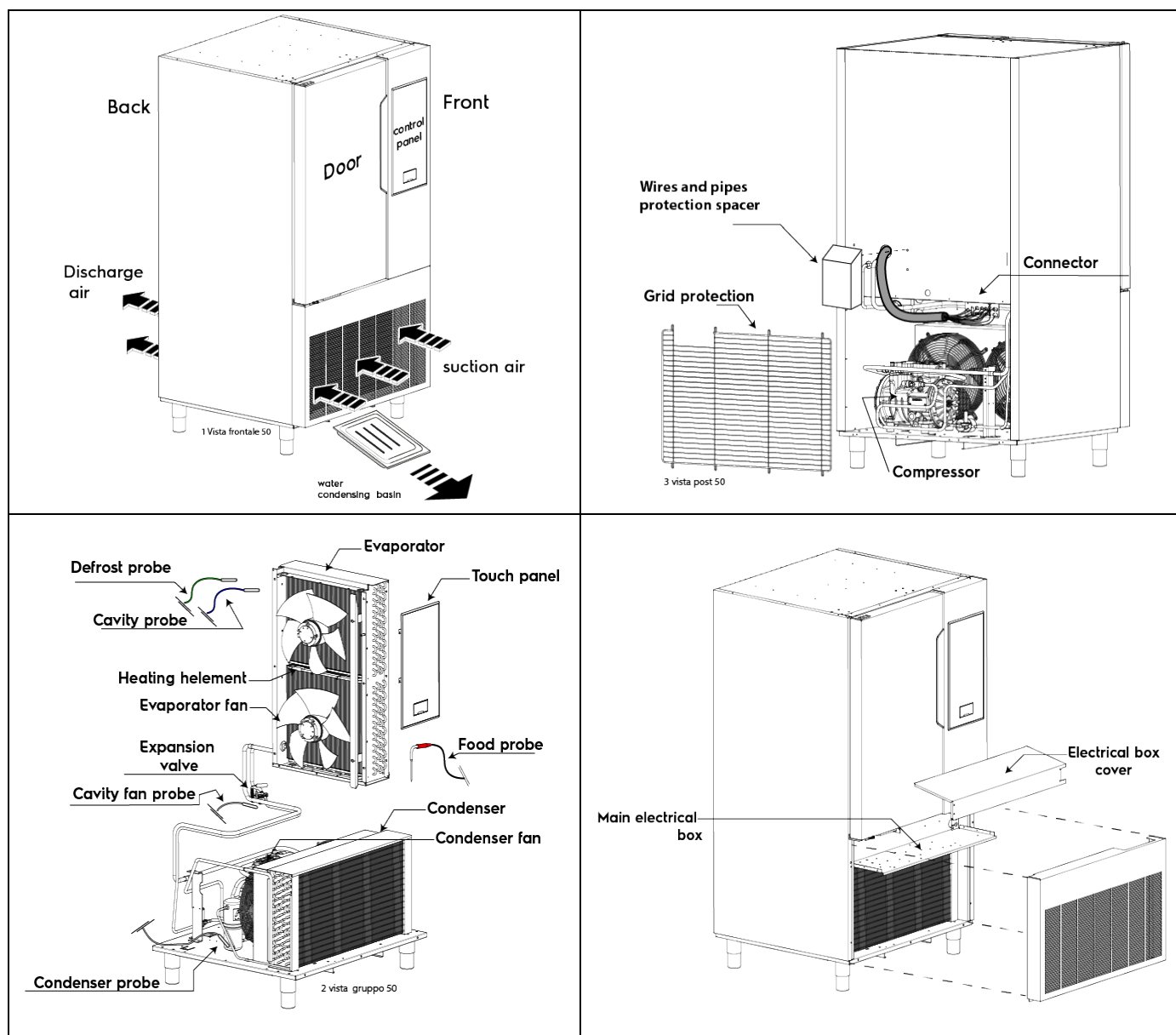



1.9.2 Electrical schema interactions 50_70 kg Europa

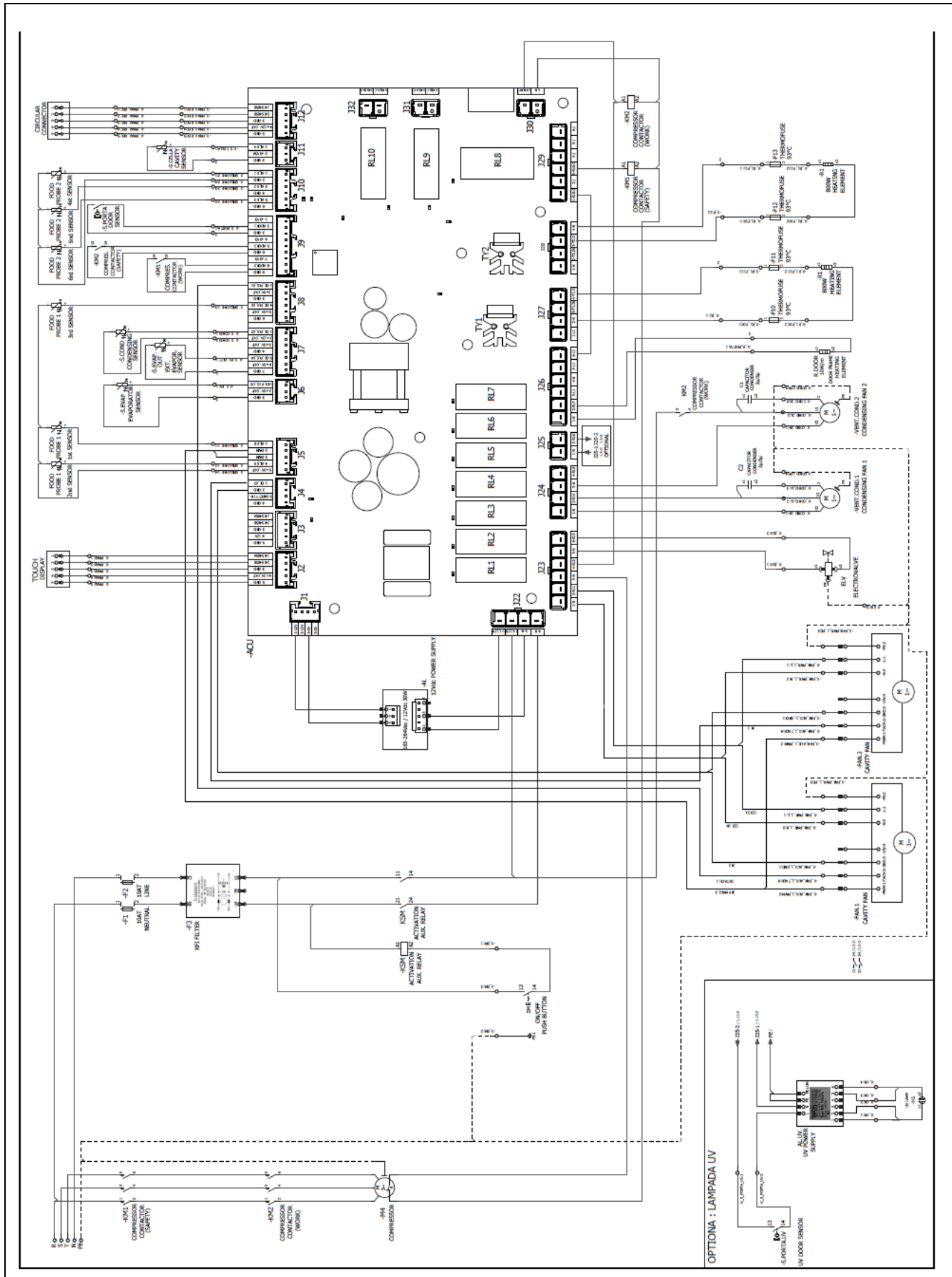



1.9.3 Electrical schema interactions 50_70 kg USA

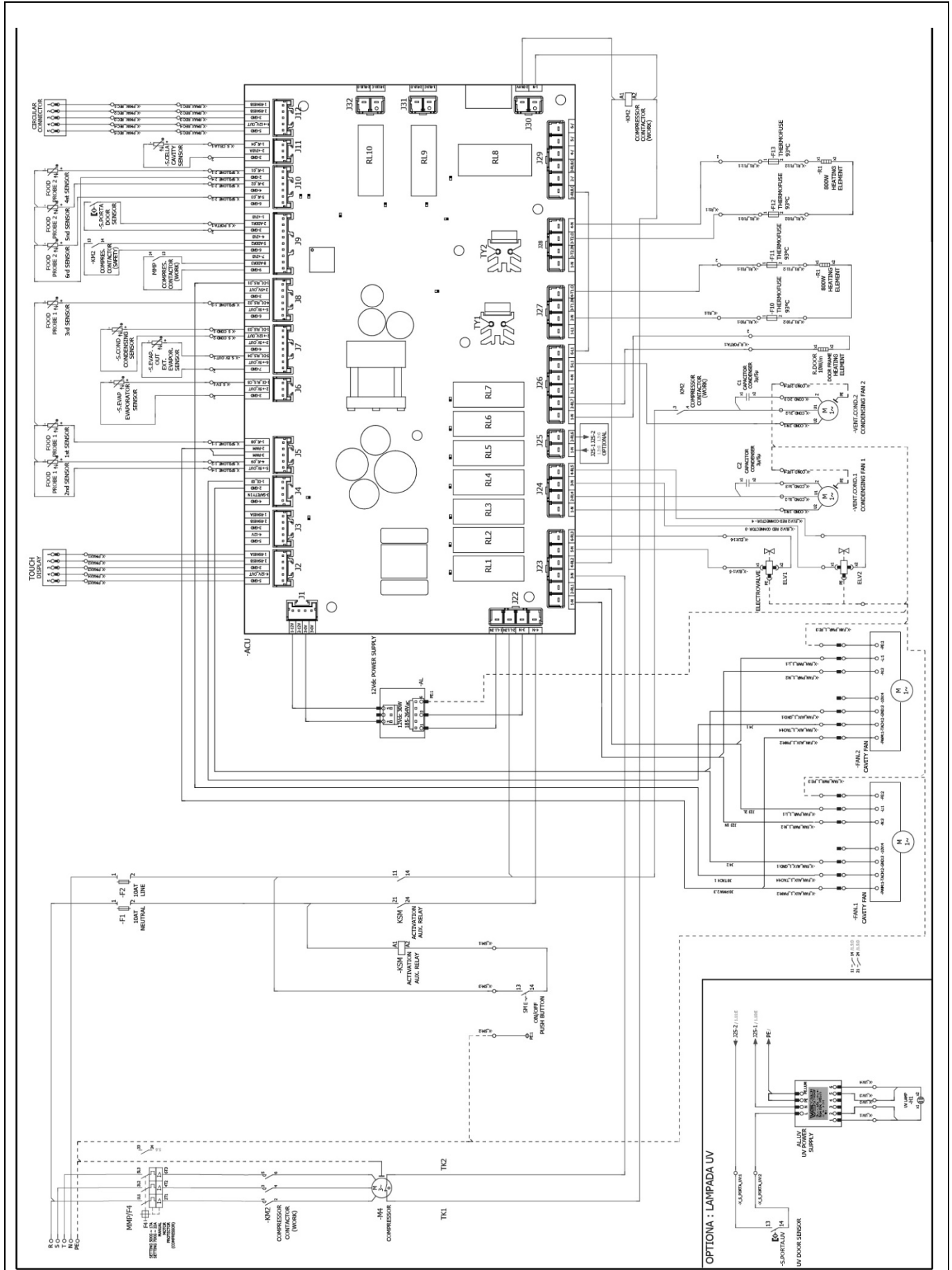



1.9.4 Blast chiller /freezer 30kg 6 gn 1/1

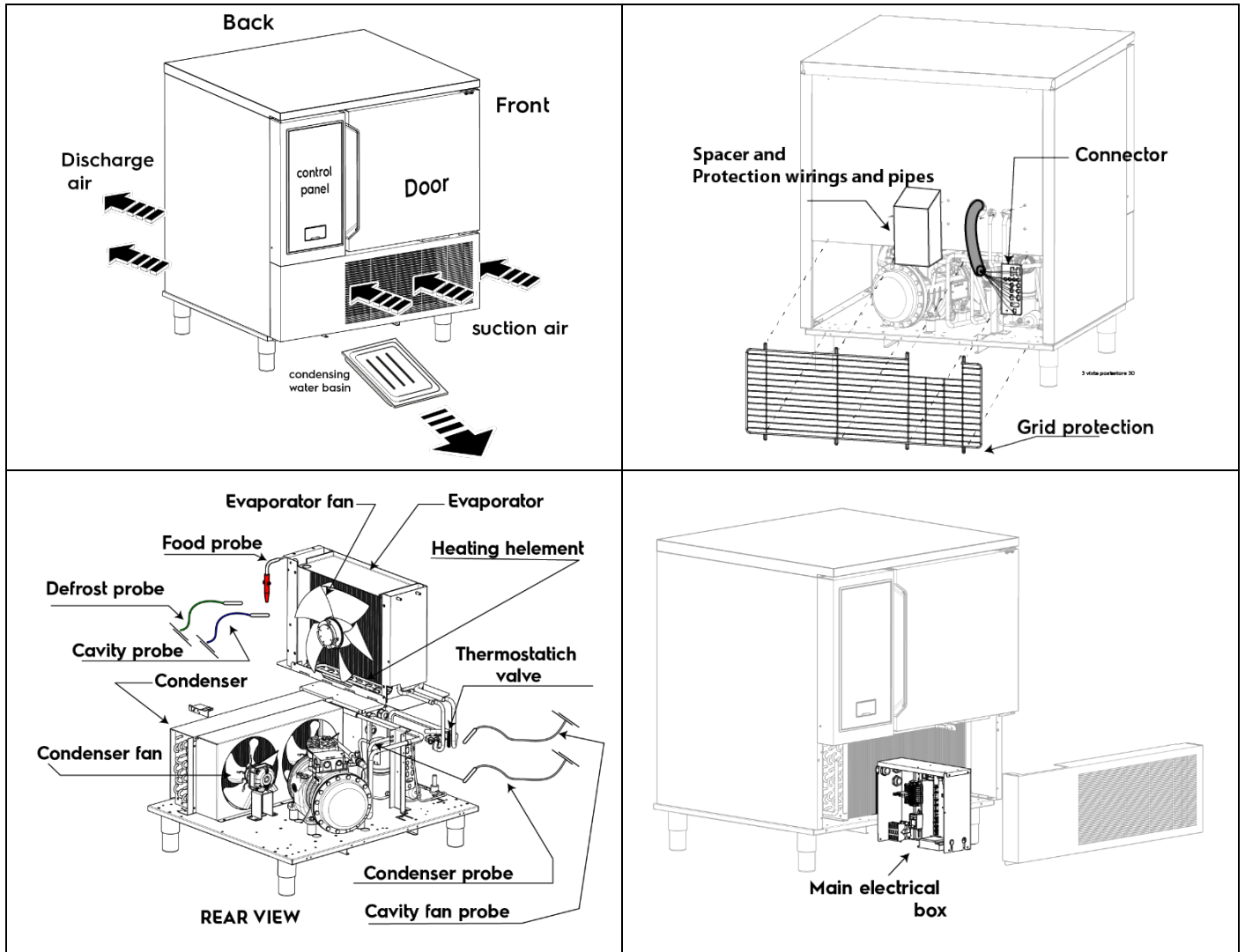



1.9.5 Electrical schema interactions 30 kg Europa

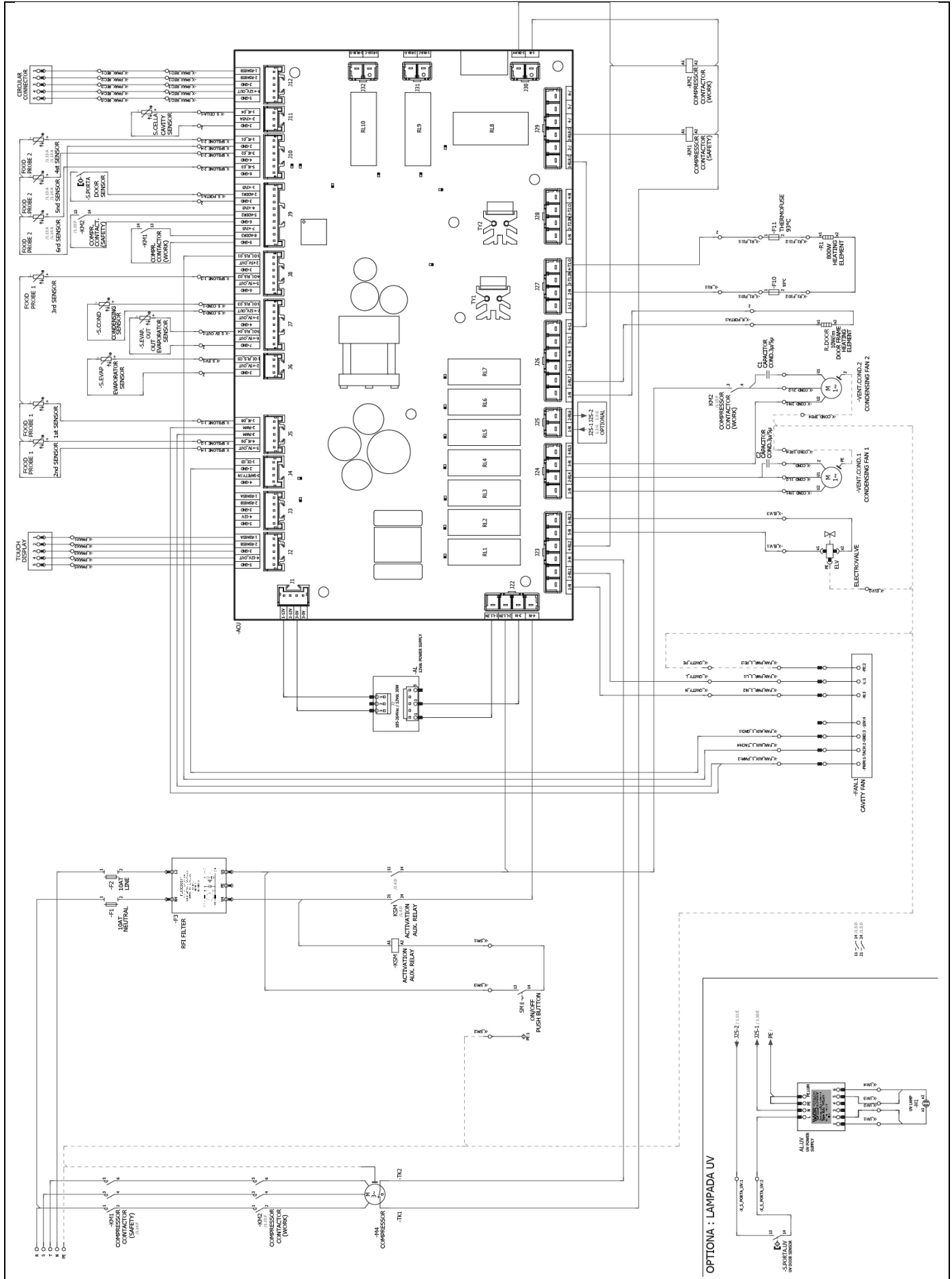



1.9.6 Electrical schema interactions 30 kg USA

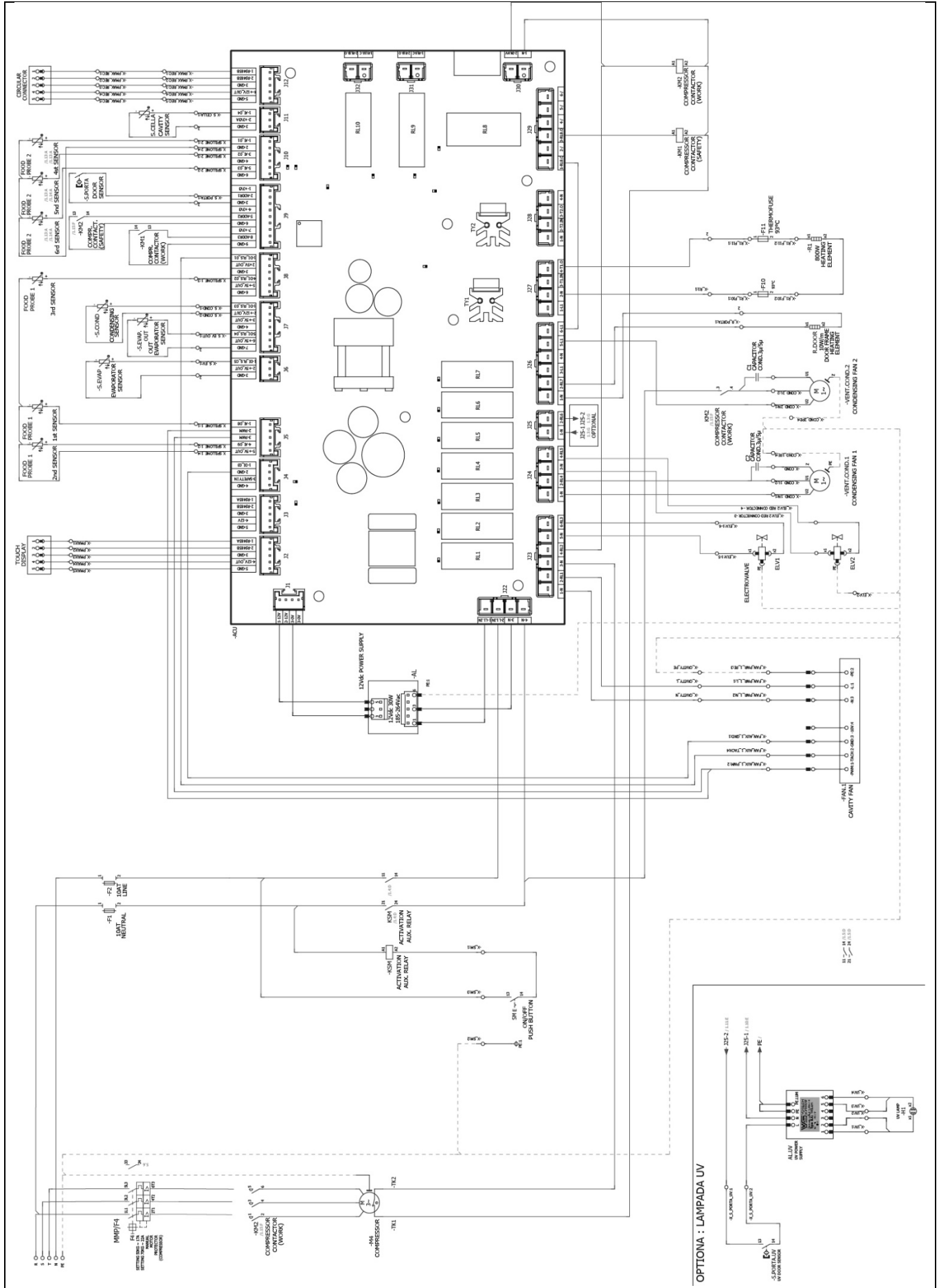



1.10 DEFINITIONS/GLOSSARY

COMPONENTS	DEFINITION	EXPLANATION
Cavity fan probe	Probe	Set the On Off cavity Fans
Cavity probe	Probe	Set the temperature of cavity
Compressor	Pump	Suction and discharge the refrigerant gas
Condenser	Heat exchanger	Reduce the temperature. of refrigerant from high to low)
Condenser fan	Fans	Fan taking the hot temperature off
Condenser probe	Probe	Temperature sensor of the condenser
Connect. term. board	Plate connections	Main SS plate where is connected all device present on cavity
Electrical box	Main electronic com.	Box with all electronic components (boards fuse, etc.)
Evaporator	Heat exchanger	Remove the hot air in the cavity
Evaporator fan	Fans	Fan to uniformity the cavity temperature.
Evaporator probe	Probe	Temperature sensor of the evaporator
Food probe	Probe (multi sensor)	Temperature sensor of food product
HP	Pressure	HP= High pressure side discharge compressor
LP	Pressure	Lp=Lower pressure side suction compressor
Thermostatic valve	Expansion valve	Increase or degrees the injection of refrigerant on evaporator



2. INSTALLATION AND COMMISSIONING

2.1 INSTALLATION

Refer to IN (Installation manual) code 595R361””

2.2 PRE-CONNECTION PREPARATIONS

Refer to the installation drawing for information about supply power connection and general clearances of the unit sides from walls and ceiling.



IMPORTANT: servicing the unit requires access to the rear side; it is therefore needed to either provide enough space to move the unit from its working position or installing the unit with space enough all around it.



IMPORTANT for remote connections piping configuration:

servicing the unit requires access to the rear side; it is therefore needed to either provide enough space to move the unit from its working position or installing the unit with space enough all around it.

Furthermore, it is highly recommended connecting the unit by using hoses in at least three turns, like shown in the picture below, to allow acceptable movement of the unit without causing damages or fractures (picture reports the scheme of 30kg model).

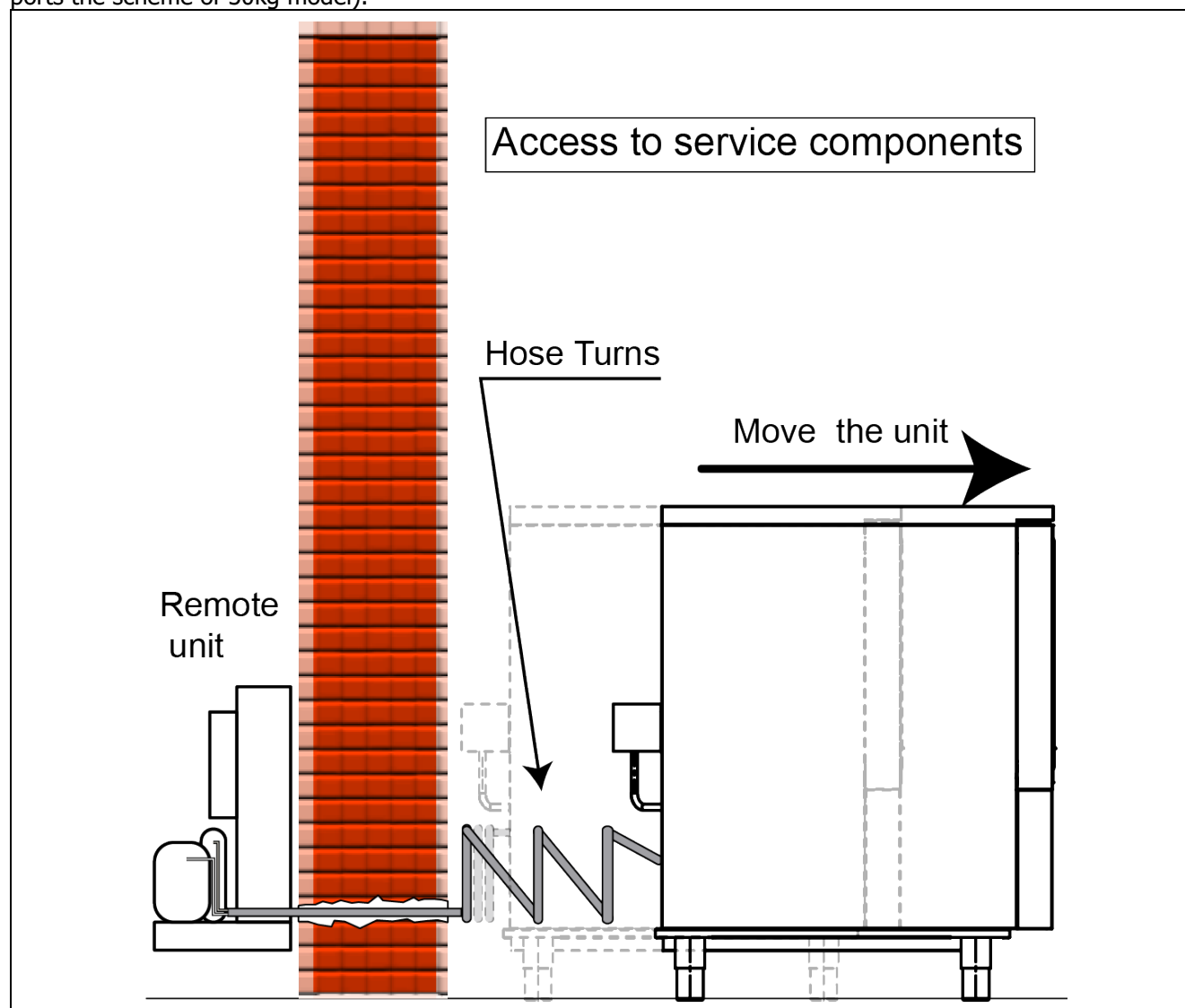



2.3 LIST OF POSSIBLE INSTALLATION SOLUTIONS

1. Casters: models with built-in cooling unit (no remote configuration).
2. Plinth: guarantee free access to the unit rear side.
3. Marine feet: guarantee free access to the unit rear side.
4. Remote configuration: see IMPORTANT note at 2.7.1.
5. Stack with oven: 30kg model (see the information below).

i INFORMATION: *BCF 30kg model can be stacked under Oven. Reference installation instructions available with the stacking kit, optional accessory of the 30kg 6gn1/1BCF (595R441--).*

2.4 ROOM REQUIREMENTS

According to IEC/EN 60335-2-89 and IEC/EN ISO 23953, room requirements depend on the unit climatic class: see the table below.

For the specific unit climatic class refer to the installation manual and to the unit data plate.

CLIMATIC CLASS	TEMPERATURE	RELATIV HUMIDITY	CONDENSATION POINT	MASS OF STEAM PRESENT IN THE AIR
3	25°C	60%	16,7°C	12,0 g/kg
4	30°C	55%	20,0°C	14,8 g/kg
5	40°C	40%	23,9°C	18,8 g/kg
7	35°C	75%	30,0°C	27,3 g/kg

2.5 REFRIGERATION POWER OF REMOTE UNIT

2.5.1 Refrigeration power table

PNC REMOTE UNIT	COMPRESSOR	Type Gas	EVAP TEM in WATT				CONDENSATION	AMB. TEMP./ Water temp.	MAX pipes USED
			-10	-20	-36	-40			
881156	H290CS	R404A	6570	4520	2050	1590	AIR	40°C	30 meters
881157	H390CS	R404A	\	5870	3430	\	AIR	40°C	30 meters
881158	H505CS	R404A	11740	8130	3690	2850	AIR	40°C	30 meters
881159	H751CS	R404A	15990	11110	6010	\	AIR	40°C	30 meters
881160	H1001CS	R404A	22190	14490	7190	5570	AIR	40°C	30 meters
881168	H290CS	R404A	6570	4520	2050	1590	WATER	10° to 30°	30 meters
881170	H390CS	R404A	\	5870	3430	\	WATER	10° to 30°	30 meters
881171	H505CS	R404A	11740	8130	3690	2850	WATER	10° to 30°	30 meters
881172	H751CS	R404A	15990	11110	6010	\	WATER	10° to 30°	30 meters
881173	H505CS	R404A	11740	8130	3690	2850	AIR and WATER	40°C	30 meters
881221	H290CS	R452A	6310	4350	2030	1590	AIR	40°C	30 meters
881222	H390CS	R452A	\	5770	3380	\	AIR	40°C	30 meters
881223	H505CS	R452A	11650	8040	3600	2770	AIR	40°C	30 meters
881224	H751CS	R452A	15620	10870	5910	\	AIR	40°C	30 meters
881225	H1001CS	R452A	21760	15140	7100	5560	AIR	40°C	30 meters
881226	H290CS	R452A	6310	4350	2030	1590	WATER	10° to 30°	30 meters
881227	H390CS	R452A	\	5770	3380	\	WATER	10° to 30°	30 meters
881228	H505CS	R452A	11650	8040	3600	2770	WATER	10° to 30°	30 meters
881229	H751CS	R452A	15620	10870	5910	\	WATER	10° to 30°	30 meters
881230	H505CS	R452A	11650	8040	3600	2770	AIR and WATER	40°C	30 meters



2.6 CONNECTION REMOTE UNIT

2.6.1 Technical Instructions / Installation Precautions

The instructions below are general guidelines, but they do contain the major points that shall be taken into account for proper and safe product installation for assuring best performances and preventing warranty voidance.



Caution: Refrigeration systems are pressurized circuits! It is therefore of the utmost importance that the condensing units are removed and / or installed only by technically qualified personnel, with knowledge of the equipment and of the processes to be adopted.

2.6.2 General Information

Inspect the unit for detecting possible damages occurred during the transport: report to the carrier immediately if any damage.

The warranty does not cover damage due to storage, transport or installation of the condensing unit carried out in the wrong position.



Warning: Make sure you have read and understand all procedures and caution messages before you execute any maintenance or installation tasks! It is imperative – for your own safety - that the testing devices used are functioning well and properly sized.

2.6.3 Basic Installation – Overview

The installation site shall be well ventilated, ensuring that there will be sufficient air flow behind the condenser (refer to Figure 1)

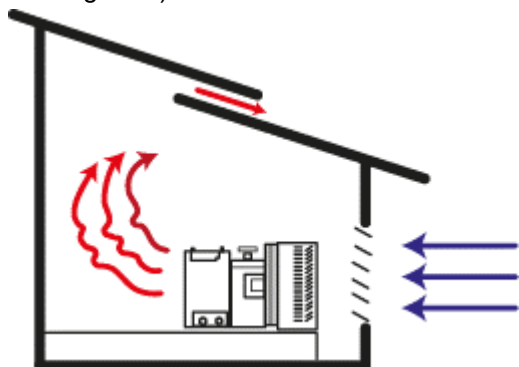

Figure 1 – Natural airflow through the roof

If the flow of air to the condenser is limited (or even partially blocked), system performance and reliability can be drastically reduced. Condensing units are designed to operate at ambient temperatures up to 43°C (110°F). Therefore, make sure that the temperature at the installation site does not exceed the recommended limit.



Warning: it is necessary to periodically clean the condenser, so that no particles damage or block the air circulation.



Warning: pay the utmost attention when working with flammable refrigerants.



2.6.4 Installation Steps



INFORMATION:

Select and size the equipment needed to assemble the refrigeration system according to the project specifications (pipes, valves, accessories, condensing unit). Carefully observe the scope for each model.



IMPORTANT: Size pipe/hose based on the condensing unit dimensions (do not size based on the evaporator).

Phases

1. **Weld the pipes to the condensing unit and evaporator connections. Check the seal (leak test) in all soldered or threaded connections.**
2. **Obtain the vacuum in the circuit (check with the pressure gauge if the vacuum is stable).**
3. **Fill the required refrigerant mass (kg): the gas should preferably be charged in the liquid phase.**
4. **To ascertain the correct behavior of the system, switch ON and monitor:**
 - a. **Low/high pressures**
 - b. **Liquid/gas lines suction temperatures**
5. **If detecting low performance or excessive pressures, fine tune the set up by either filling more refrigerant or discharging it until reaching the correct pressures/temperatures (see below additional general notes for more details).**

Refrigerant mass set up:

- Taking into account both the temperature set on the BCF chamber and the temperature where the remote condenser is installed, when the liquid/gas lines suction temperature gets closer to the design values, proceed with the final adjustments (phase 5 mentioned above).
- The superheating at the evaporator (given by the difference between temperatures at the piping surface at the point where the expansion valve's sensor is fixed, and the evaporation temperature^(*)) shall be between 5°C and 10°C (9°F and 18°F). Superheating at the compressor's inlet must be between 10°C and 15°C (18°F and 27°F), where in such case it is the difference between the temperature at the surface of the return pipe, at a distance 150 mm (6") from the compressor, and the evaporation temperature. The sub-cooling in the condenser shall be between 3°C and 10°C (5°F and 18°F), i.e., the condensing temperature less than the temperature at the pipe's surface at the condenser's outlet.

() Evaporation temperature obtained by converting the suction pressure into temperature.*

Cleaning the System (in case condensing unit replacement):

- Cleaning the system before installing a new condensing unit is mandatory to completely remove residues and other contaminants.
- The manufacturer recommends the installation of a filter-dryer at the suction line during the cleaning operation to retain and filter any undesired particles
- It is recommended to make the joints by braze-welding

Welding operations:

- While welding keep nitrogen (N₂) circulating into the pipes with a pressure between 1 and 2 psig (equivalent to 1.08 - 1.15 bar): this will prevent oxidations and scale forming, hence ensuring that the piping is free from any contaminants (oil, grease, oxides).
- Use a damp cloth when welding valves or fittings or pipes to prevent the components overheating because of the heat propagation.
- The compressor and the filter-dryer are extremely susceptible to humidity. As such, they shall only be opened during installation or replacement phases. In case of opening, do not leave them exposed to air for more than 10 min.

Leakage test

- During the system leakage tests, never pressurize the pipes using air, oxygen or acetylene. There is a potential risk of fire and/or explosion.



- After the installation is finished, pressurize the system using nitrogen and/or a small refrigerant charge up to 100 psig (equivalent to 7,8 bar); never use pressures higher than 150 psig (equivalent to 11.35 bar) for preventing the low-pressure switch damage.

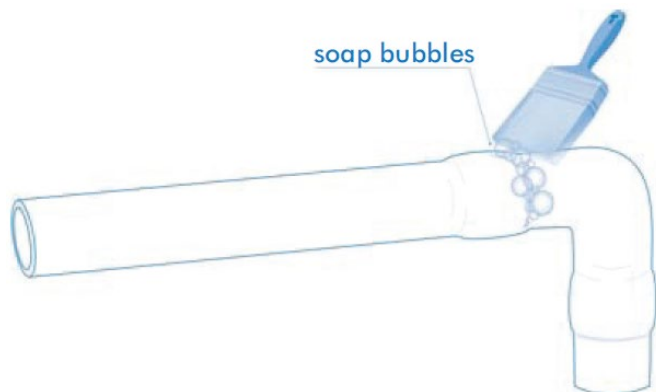

(Figure 2) Leakage tests with soapy water bubbles

- Check for leaks using an electronic detector or a halide detector (torch). An alternative method is to check leakage with soapy water bubbles (see Figure 2). When all fittings are properly checked, depressurize the system and go to the next step.

2.6.5 System Evacuation



Warning: Never use the compressor itself to evacuate the system, nor energize the system when it is under vacuum, as it may cause the compressor be damaged because of short-circuit caused by overload.

To evacuate the system, use a high vacuum pump and a vacuum gage. The system shall be evacuated up to 0,5mmHg (equivalent to 0,0066bar) or less. In any case, at least 20 minutes of vacuum must be applied (see Figure 3)

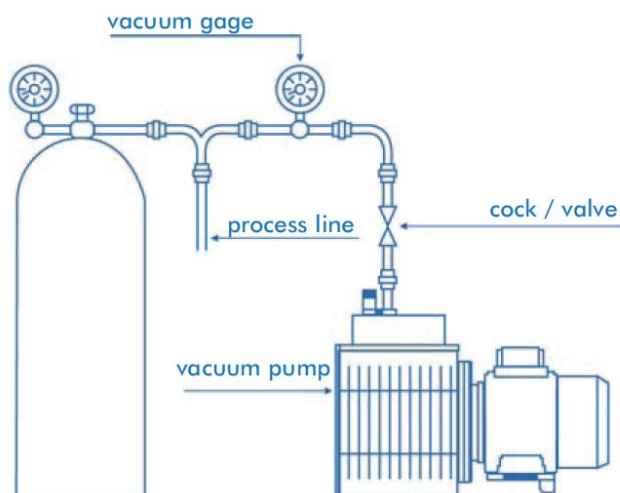

Figure 3 – Vacuum operation scheme



Warning: Never use anti-freeze elements (methyl alcohol and derivatives), as they cause irreversible damages to the cooling system.

2.6.6 Procedures for Refrigerant Charge

The refrigerant shall only be charged after the proper vacuum has been achieved. Please check on the compressor or condensing unit tag what is the type of refrigerant that should be used to charge the system. Break the vacuum only when the compressor is switched off.

It is recommended that the refrigerant charge be provided in the liquid state (with the compressor switched off), through the high side (tank liquid valve) and by the refrigerant mass measurement (kg), according to the system specification.



Wait for 15 minutes before switching on the system again, to allow the gas to be evenly distributed and balance the pressure levels.

The fine-tuning of the refrigerant charge must be done while the system is running (compressor switched on), by observing the sight glass. The charge will be complete when there are no more bubbles forming.

When performing a condensing unit replacement always check the specified refrigerant charge.

2.6.7 Piping

Piping shall be sized so that:

It is flexible, to avoid rupture due to expansion and due to the transmission of vibration usually caused by compressors.

Ensure that the refrigerant is well distributed through the evaporator(s), and prevent the liquid from flowing back to the compressor. To do that, use an expansion valve with proper dimensions, and an inverted siphon at the outlet of each evaporator.

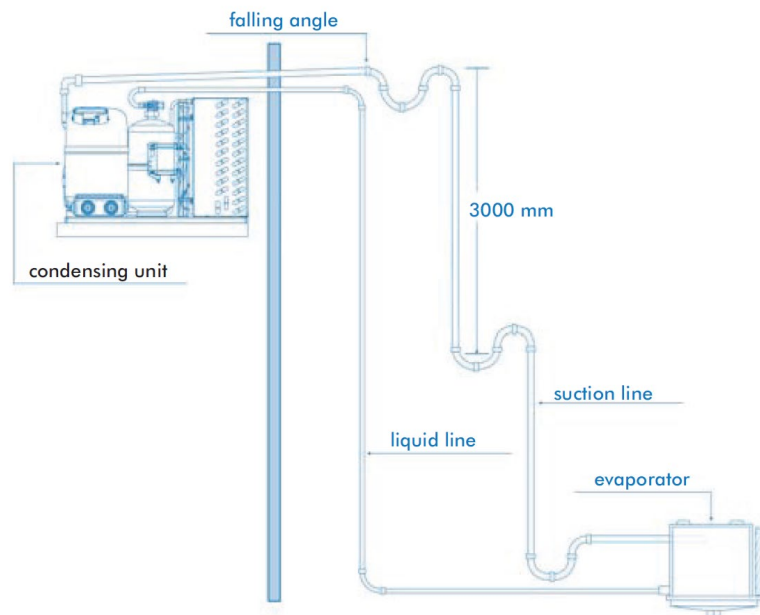

Figure 4 – Evaporator under the condensing unit

Prevent the liquid from flowing back to the compressor when the system stops and the evaporator(s) is/are located above the Condensing Unit, using an inverted siphon and suction accumulator (see Figure 4).

Aid the return of lubricating oil coming from the evaporator(s) to the system where the Condensing Unit is located over 3000 mm above the evaporator(s), using an inverted siphon every 3000 mm in the piping.

Allow secondary operations, such as attaching measurement instruments, isolating stretches for maintenance purposes and pump down.

Warning: The diameter of the fittings for the condensing units and evaporators shall not be used as a parameter to select the diameters of the other system components.

Warning: After replacement the condensing unit and its accessories must be handled and recycled according to the material group (ferrous, non-ferrous, polymers, oils,) directives. These recommendations are intended to minimize the adverse impacts on the environment.



2.6.8 Basic Accessories of a Cooling System

	<p>Filter-Dryer Installed at the liquid line, its function is to retain particles and mainly remove residual humidity from the system.</p>
	<p>Sight Glass It is installed at the liquid line, just after the filter -dryer and used to monitor the system refrigerant charge. Some models also allow humidity detection.</p>
	<p>Pressure Control Some Condensing Units are fitted with High / Low Pressure Switches. Their function is to prevent the compressor from operating under pressure levels that are outside of their application range.</p>
	<p>Solenoid Valve It is installed at the liquid line, prior to the expansion valve and used for the pump down procedure.</p>
	<p>Oil Separator It is installed at the discharge line, when the evaporator is below the compressor's height (long distances)</p>
	<p>Suction Accumulator It is installed at the suction line, just before the compressor. It prevents liquid refrigerant from flowing back towards the compressor.</p> <p>Conditions that favor the flow-back of liquid to the compressor and where the use of a suction accumulator is recommended:</p> <ul style="list-style-type: none"> • Systems with more than one evaporator • High refrigerant charges • Operations with defrosting by hot gas • Where the distance from the compressor to the evaporator is over 15 meters (50 feet) • Evaporator(s) above the condensing unit
	<p>Fan Speed Control The Fan Speed Control controls the head pressure in air-cooled condensers by reducing the fan speed to maintain head pressure as the outside temperatures/condenser pressure drops. As the motor speed drops under lower ambient/load condition fan noise is also reduced.</p>



	<p>Schrader Valve Used for service operation (Refrigerant Charge).</p>
	<p>Suction Filter It is recommended to clean the systems if the compressor has burned out. Installed at the suction line, its main task is to retain the contaminants (result of the burning of the compressor), and to retain system particles.</p>
	<p>Fuse plug A/C systems can include a pressure release valve that is usually mounted at the compressor or fuse plug mounted on the receiver dryer. The relief valve can open at a preset pressure and then reclose. The center of the fuse plug melts to let pressure escape. In case of release the melt part replace with new one same capacity.</p>



2.6.9 Expansion Valve

It is installed at the liquid line, before the evaporator.

Its function is to keep the pressure different between the condenser and the evaporator; it also adjusts the refrigerant flow within the evaporator. For systems operating under low evaporating temperatures (lower than -17.7°C (0°F), it is recommended using an expansion valve fit with MOP (Maximum Operation Pressure), to protect the compressor against high pressures during the suction phase at the start of the procedure.

2.6.10 Setting the Expansion valve

The valve is already set from factory in the standard condition and it is suitable for most installations.

If adjustment is needed, it is possible proceeding by means of the expansion valve rod adjustment.

By rotating the rod clockwise, the expansion valve overheat increases, while turning the rod counterclockwise then it will decrease the overheating

IMPORTANT: Turn the rod maximum 45° each time; wider rotations will provoke flash-gas!

To eliminate evaporator swing, increase overheating by turning the rod clockwise until it stops.

Rotate the rod anticlockwise step by step until the swing will reappear.

From this position, turn the rod 45° clockwise.

When the calibration is done (swing approximately at the average), the refrigerator will no longer swing and the evaporator can be considered as working at full capacity (see Figure 5).

If overheating in the evaporator is too high, this may be either due to an insufficient refrigerant fluid mass or to an insufficient dimension of the thermostatic valve (thermostatic valve not sized correctly).

Note: Variations of the overheating of $\pm 0.5^{\circ}\text{C}$ are not considered swing.

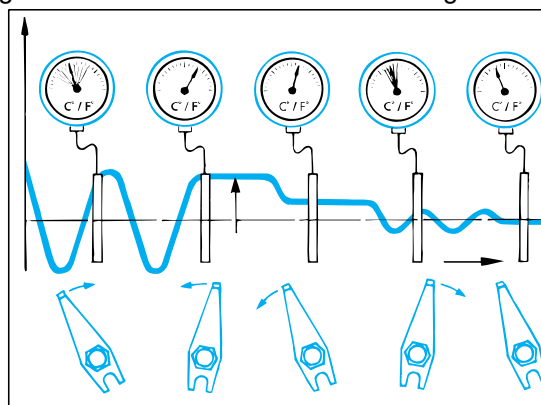

Figure 5

2.6.11 Correct position of the thermostatic sensor

It is recommended to mount the sensor on a horizontal section of the suction line as close to the evaporator as possible and in a position corresponding to the watch hands between 1 and 4.

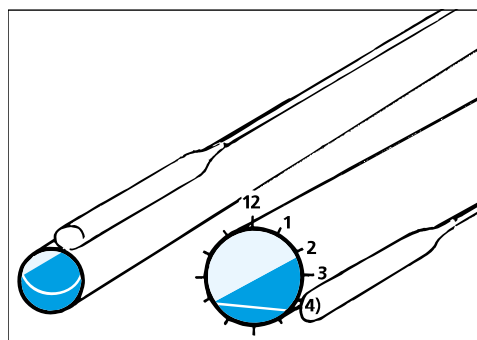

Figure 6



2.6.13 Charge MOP

All MOP valves have a very small charge in the sensor.

This means that the valve or the element should be placed in the hottest position of the sensor otherwise a charge migration may occur from the sensor to the element and the expansion valve will stop working.

The MOP charge has a limited charge in the sensor.

MOP means Maximum Operating Pressure (sometimes called "Motor Overload Protection") and is the maximum suction / evaporation pressure allowed in the suction / evaporation line.

The refrigerant liquid will evaporate when the temperature reaches the MOP point. As the suction pressure increases, the expansion valve starts reducing the pressure to 0.3 / 0.4 bar, below the MOP point, until fully closing when the suction pressure will be equal to the MOP point.

2.6.14 Quantity of refrigerant to charge

The exact quantity of refrigerant to charge (see Figure 10) in the system depends on:

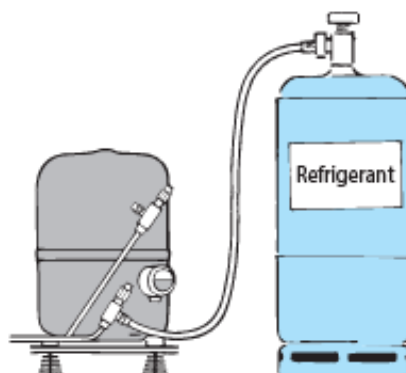

Figure 10

1. **Data plate identification (in case of remote unit the reference are points 2 and 3)**
2. **Liquid container receiver (max quantity in kg of refrigerant)**
3. **Liquid spy (see Figure 11) on the system.(where present)**

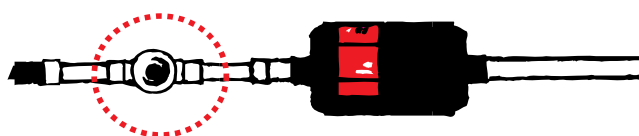

Figure 11

COMPLETE OPERATIONS IN SUMMARY - After correct cleaning and vacuum of the system:

- a) Start to charge the refrigerant on suction/service pipe on the compressor.
- b) Keep the appliance door opened
- c) Switched ON the appliance
- d) Charge a small amount of refrigerant step by step without freezing the pipe until air bubbles show on liquid spy.
- e) Close the door and verify the evaporation pressure.
- f) Check the overheating on external pipe of evaporator following the evaporation pressure/temperature
- g) Check for presence of swing of pressure due to thermostatic valve (refer to chapter 2.5.10)
- h) In case of swings, set the valve or add refrigerant.



Warnings: Do not provoke flash gas!!!! The pipe must be slightly cooled not frozen!!



2.6.15 Electrical connection

Use the separate power supply from remote unit and bcf.

For the power supply dimensioning, check the electric wiring diagram of the appliance: after retrieving current absorption and power data relevant to the live lines, determine the cables sections able to support the ab-sorbed current.

In order to detect the remote unit alarms, the connection between it and the BCF must be done with a six-wire cable whose section is sufficient for signals.

The BCF electric wiring diagram shows the correspondence between the clamps of the remote unit and of the BCF: labels are then present on both the remote unit and the BCF terminal clamps.

The main labels are:

T1-T2 = connection of power compressor

AP_AP = Alarm pressostat

AT_AT = Alarm Thermic compressor

More detail is in the chapter 2.6.15 (Electrical drawing present on electrical box of remote unit)

2.6.15.1 Electrical box drawing on remote unit

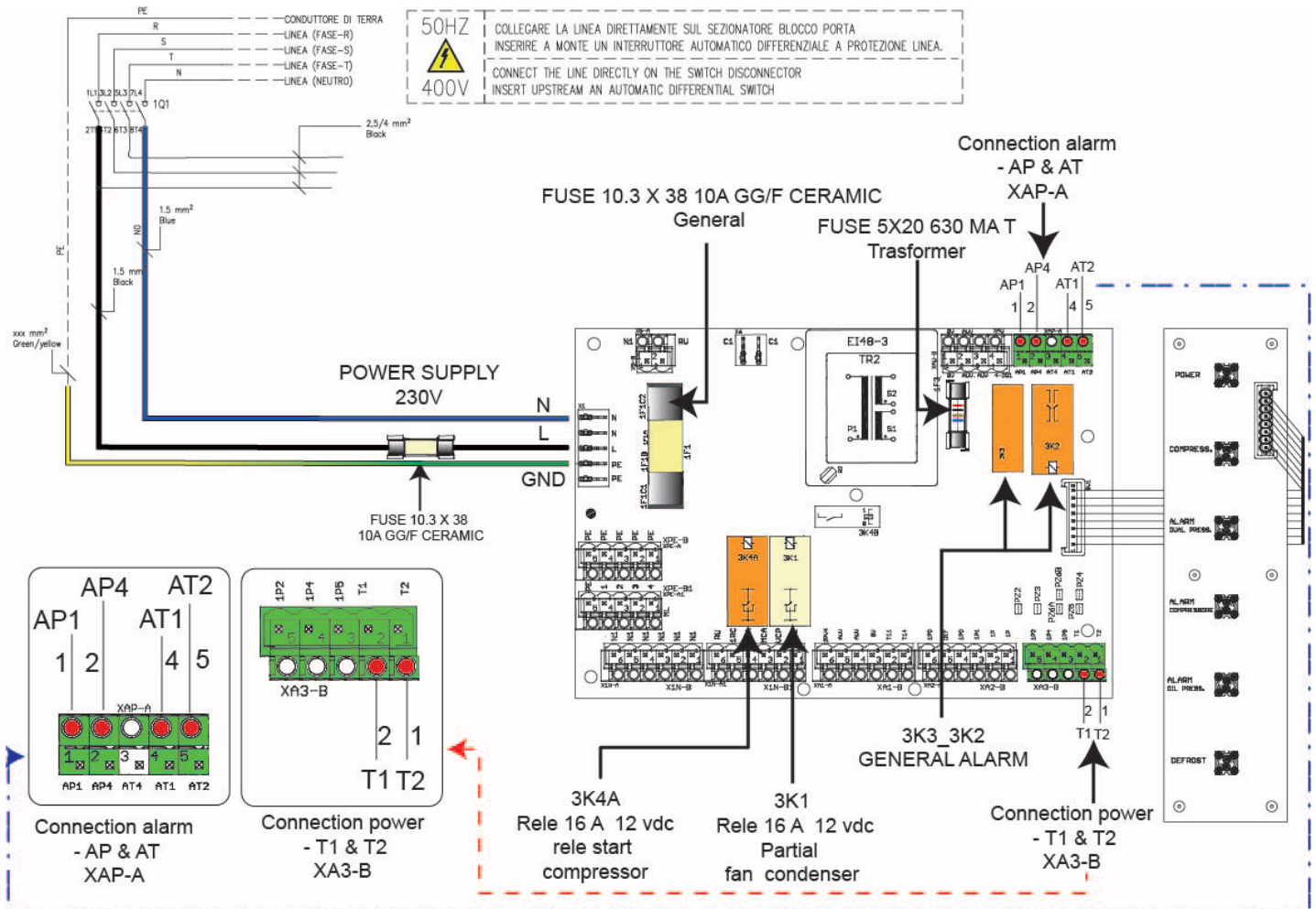



2.6.15.2 Electrical box in the BCF: IE. Of clamp connections

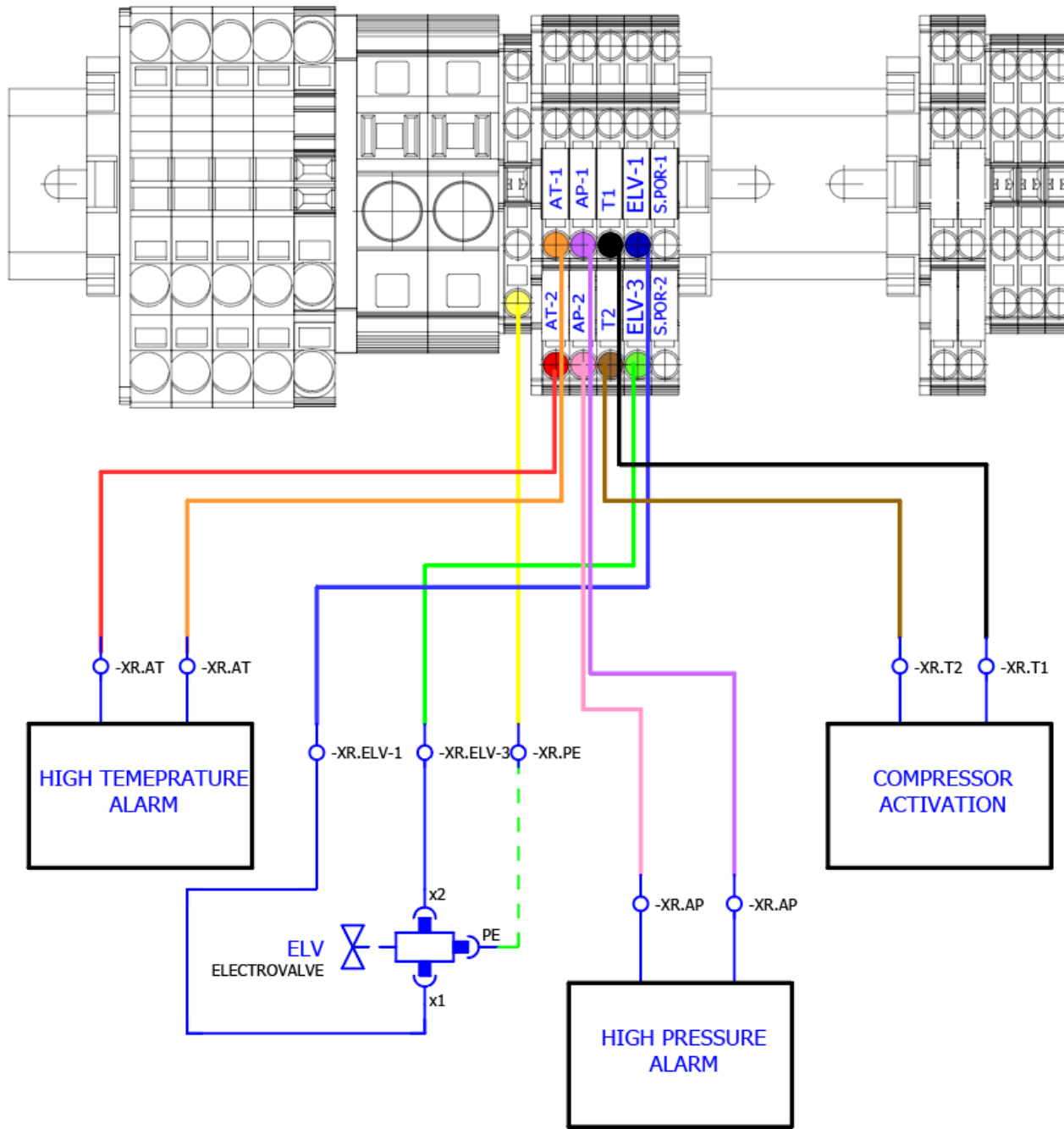

Warning: Remember use DIFFERENT power supplies for energizing the BCF and the remote unit.



2.7 UNPACKING AND POSITIONING THE EQUIPMENT

See reference instructions provided with the INSTALLATION MANUAL.



Warning: assemble the guides for the condensing tray only after positioning the unit in its final location – Risk of damaging the guides if moving the unit with fork-lift when the guides are in place.

In case the unit are too large for movement in the room, it is possible reduce to remove the following parts and gain some increased handling:

- Door
- Control panel
- Condenser panel
- Door hinge
- Rear side protection box (after removing the box pay attention not to damage pipes and cables)
- Bracket of door micro switch
- Foamed panel



Warning: before testing the unit, reassemble all the removed parts (also reseal the components showing silicone traces) and check the door alignment.



2.8 COMMISSIONING

2.8.1 Power connection on bcf 380/400V

The units built-in are already predisposed with power cable, usually without plug.

The reference to the adsorbed current and the voltage are on the unit data plate.

The color of the main conductors present in the power cable are standard as:

- Blue = N neutral
- Dark= L1 Phase
- Grey= L2 Phase
- Brown= L3 Phase
- Yellow and Green= Heart

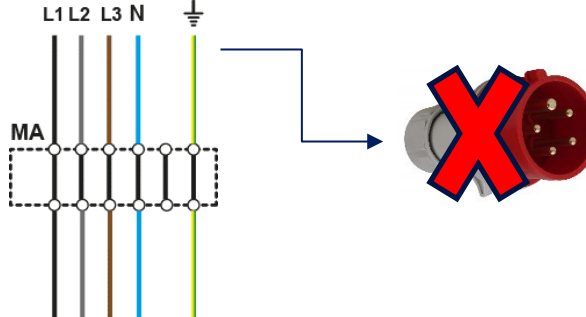

NOT USE THE PLUG!
IT IS MANDATORY USE A PERMANENTLY CONNECTED

The readings should be:

L1 / L2 / L3	+	N*	(Phase and Neutral)	~ 230 Volts	(± 6% based on European standards)
L1 and/or L2		L3	(Phase and Phase)	~ 400 Volts	
L1 / L2 / L3		⏚	(Phase and Earth)	~ 230 Volts	
N		⏚	(Neutral and Earth)	~ 0 Volts (or approx. zero V)	



Warning: The combination and results obtained will permit you to find all wires: PHASE, NEUTRAL and EARTH.

2.8.2 Power connection on bcf 208V (USA)

The units built-in **are not predisposed with power cable.**

The reference to the adsorbed current and the voltage are on the unit data plate.

The color of the main conductors present in the power cable are standard as:

- White = L1 Phase
- Grey = L2 Phase
- Brown = L3 Phase
- Yellow and Green= Heart

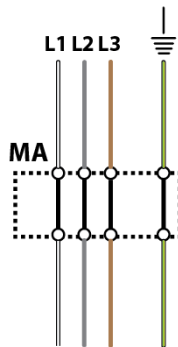

The readings should be:

L1 and/or L2	+	L3	(Phase and Phase)	~ 208 Volts
L1 / L2 / L3		⏚	(Phase and Earth)	~ 120 Volts



Warning: The combination and results obtained will permit you to find all wires: PHASE, and EARTH.



Warning: The power cable must be installed from technician, following the normative present in the local place. The connection will be done on clamp present under the condenser panel and in the electrical box predisposed for this connection. Other information are present in the Installation manual (USA)



2.8.3 Description Main Display

A	Main display Touch screen	1	Start button
B	Button ON OFF button	2	Utility drawers
C	USB key in/out	3	Multiphase drawer
D	Other connection aux	4	Main menu drawer
E	Open able flap	5	Cycle selection buttons
		6	Temperature area
			Time area



Warning:

After pressing the ON/OFF button, the display illuminates and shows the screen below, in Manual mode, with the default cycle:

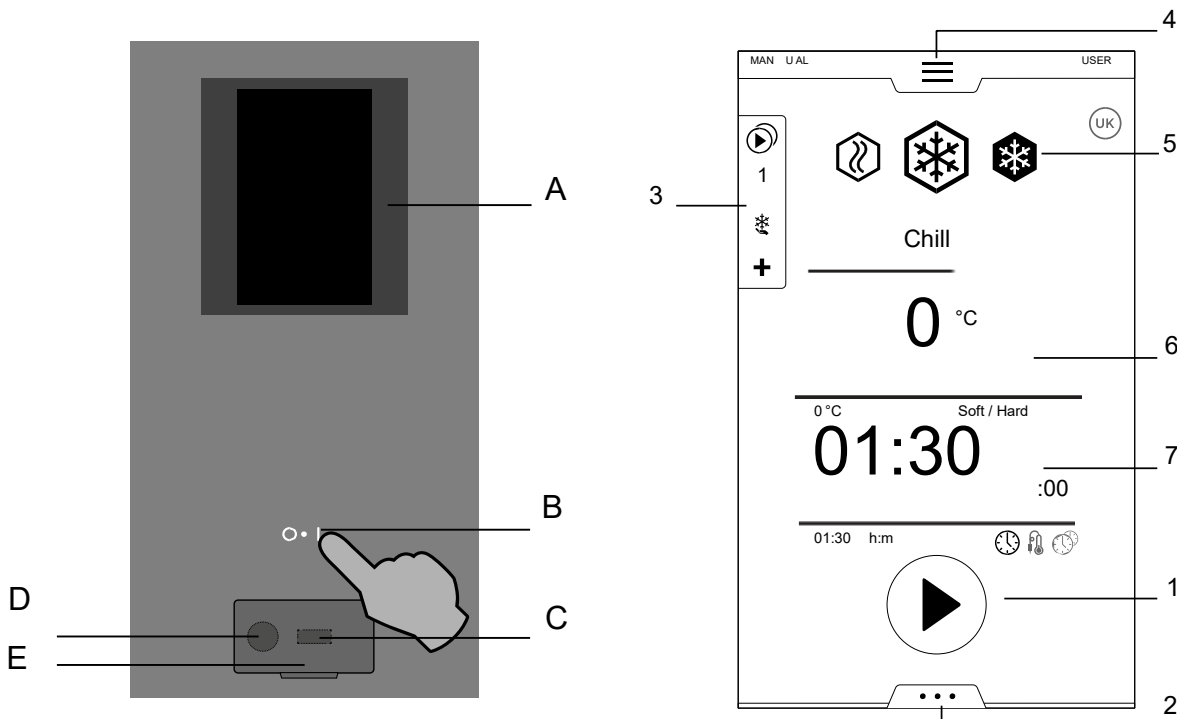



2.8.3.1 Icon description, Message of Dialogues

	Temperature set		Move between the pages
	Soft chill cycle Hard chill cycle		Move between the pages or increase/decrease a value
	Skip phase		Move between the pages or increase/decrease a value
	Time icon		Sky hub
	Multitimer icon		Settings
	Delayed start		Chilling cycle
	Time (daily)		Freezing cycle
	Delayed start		Lite Hot cycle
	Restore Multi Time program		Stop cycle
	History (cycle, temp.)		Start cycle
	Probe icon		Automatic cycles
	Precooling cycle		Programs (personal)
	Preheating cycle		Hygiene
	Cruise chilling		Data Monitor
	Turbo cooling		Drawer (up or down)
	Defrost cycle		Manual cycles
	Conserve cycle		Door open.
	Help		Alarms.
	Warnings pop-up		Compressor
	Information		User
			Agenda



	Confirm and save the selection		Guidelines
	Discard the selection or close a pop-up		Multicycles
	Come back to the previous menu		Save program
	Clear all phases		Save all pre-sets
	Delete the pre-set		Save MT program
	Clear all pre-sets		Date (daily)
	Read messages		Unread messages
	Read message with attachment		Unread message with attachment
	Training		Language
	Media		Software update
	Graphs		Sky Duo
	Fan Speed		Measurement Units
	Display (setting)		Touch screen calibration
	Touch screen test		Auto start
	Special cycles		Default setting
	Accessory		Messages
	Wi-Fi		Chiller Identity Card
	Change password		Service area
	Duplicate the Pre-set		Sound
	Automatic Drying		Soft Drying
	Strong Drying		Germicidal Cycle

*Please to reference to description of icons and messages dialogues to User manual code 595R362...



2.8.4 Softwar update

The software for each PNC is available for authorized technicians on the web sites (PRIDE-SERVICE PORTAL- AGELUX etc..) and can be downloaded in a zip file. For those that do not have access to the web sites, refer to your local country customer care.

The software to update an oven is divided in three different files

- **Programming File**
- **Programming Parameters**
- **Pnc & Ser upload (pncSerial.json)**

each file can be installed individually but we mandatory recommend to install the first two files at the same time while the Pnc&Ser is needed to be installed only when replacing a **power board**.

The three different software files can be downloaded from the official tech web pages (hereafter are some pics of the files appearance in PRIDE).

PRIDE WEB SITE- EXAMPLE ILLUSTRATION

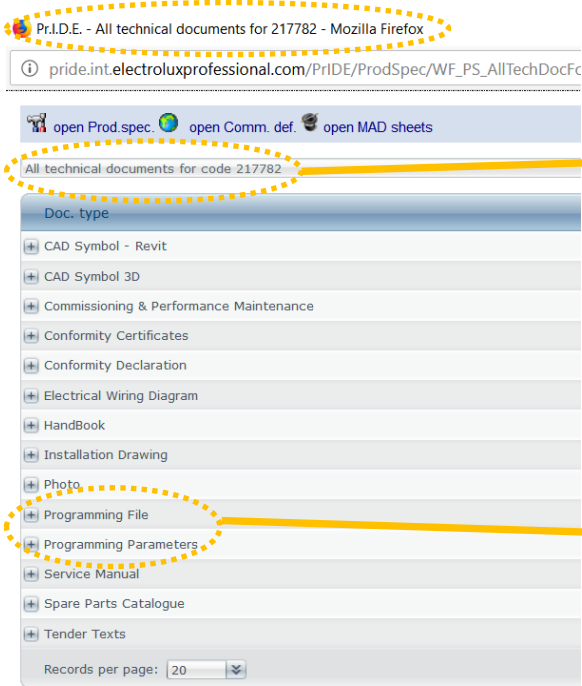

All technical documents for code 217782

NOTE: The files are specific for each PNC therefore you must download a Programming File or Programming Parameters dedicated for the exact required PNC that you need to update!.; in the images we have used for example PNC 217782.

NOTE: Programming File and Programming Parameters can be found in root tech documentation for pnc of the unit.

+ Programming File

+ Programming Parameters

pncSerial.json - EXAMPLE ILLUSTRATION

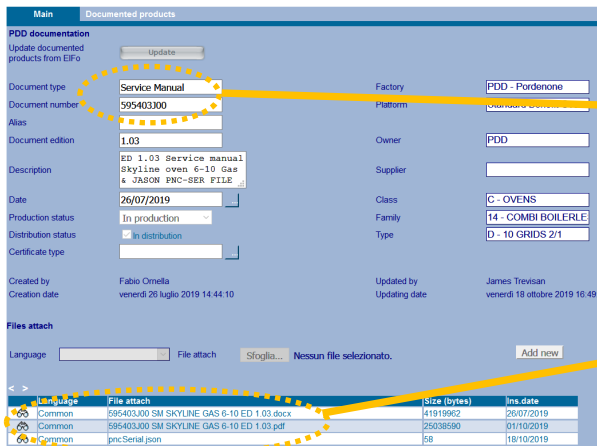

NOTE: pncSerial.json can be found attached to the SERVICE MANUAL

Common pncSerial.json

Download zipped software file from the web site and unzip it into a USB key into the main root (not in sub folders / refer to the example picture).



2.8.5 Programming file

The Programming file (that from now on we will call **P.F** as abbreviation) is the software application of the bcf and this is stored in the U.I.

The **P.F.** will update the software edition refer to the UI App version at chapter § [BCF IDENTITY CARD](#)

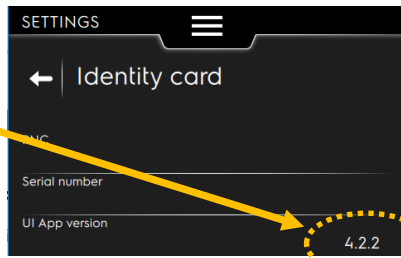

4.2.2

In case of need to update the software of the bcf it will be necessary to download locally the **P.F** and then upload the **P.F** into the oven via USB key.

The **P.F** installation will NOT erase the recepies of the customer nor change any personalization, parameters etc ; the software update will update the application , not the parameters!!

WHEN TO UPDATE:

- when ever you see an older version U.I application software
- in case of any spare part replacement (UI, ACU, BRIDGE or INVERTER)

NOTE if a **P.F** has been updated it is mandatory to install also the latest parameter file.

2.8.5.1 How to update:

In the previous chapter § [SOFTWARE UPDATE BCF \(TOUCH SCREEN\)](#) we have explained were to locate the **P.F** in the PRIDE web site; double click to unzip and locally save the **P.F** into your USB key in the root. It is preferable to have the following USB type: **USB TYPE 2.0 8Gb or 16Gb FAT 32 FORMATTED**

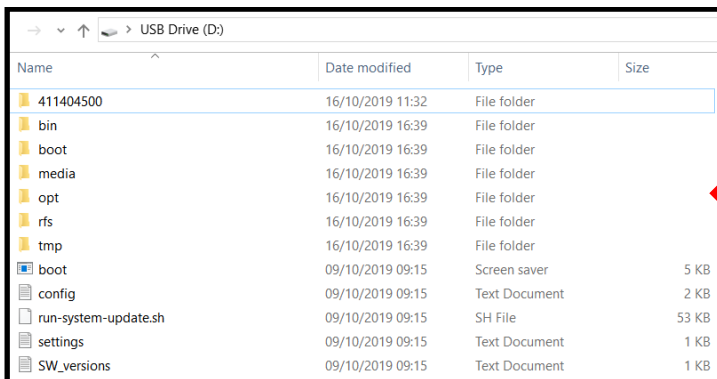

Appearance of the **P.F** when unzipped and locally saved on your USB key in root.

NOTE that in this picture we have already downloaded into our USB the **P.P** (programming parameters) folder 411404500, the **P.P** and **P.F** do not interfere between each other

Once that the **P.F** is locally installed in your USB key:

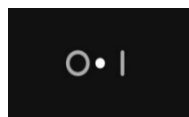

Turn OFF
The bcf



Insert the
USB Key

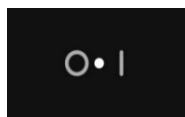

Turn ON
The bcf

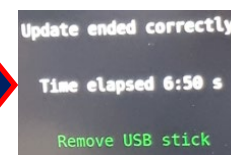
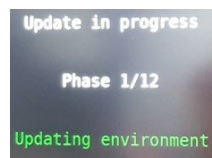

The bcf will update; follow display instructions / Extract the USB Key without turning OFF the oven when requested

The unit will automatically reboot and install the application; on the display will appear a pop up indicating the operation is in progress.

The software will update the **UI, ACU, BRIDGE and electronic boards.**

The **P.F** installation will NOT erase the recepie of the customer nor change any personalization, parameters etc ; a software update will update the application , not the parameters!!



NOTE:

- in case of power loss during installation, in case of extraction of the USB Key during installation or other maneuver error, don't worry; The update process can be restarted again without damaging the appliance.
- In case of errors or problems with the detection of the USB Key, upload the software into another type of USB key (manufacturer/dimension size) it could be that some USB key manufacturers cannot be read by the unit.

2.8.6 Programming parameters

The Programming parameters (that from now on we will call **P.P** as abbreviation) is the complete parameter list. The parameters contained in each list/appliance are more informations, but only a fraction of the parameters can be set by "hand" in the service area by scrolling in the parameter list and manually changing the value. The "hidden" parameters are for factory eyes only, they are algorithms or sensible values (any unnecessary changement could block / jam permanently the electronic board).

In case of need to update a complete parameter list it will be necessary to download locally the **P.P** and then upload the **P.P** into the oven via USB key.

WHEN TO UPDATE:

- always after any software update (**P.F** programming file upload)
- in case of any spare part replacement (UI, ACU, BRIDGE)

2.8.6.1 How to update:

In the previous chapter § SOFTWARE UPDATE BCF (TOUCH SCREEN) you have located the **P.P** on the PRIDE web site; double click to unzip and locally save the **P.P** into your USB key in the root. It is preferable to have the following USB type: **USB TYPE 2.0 8Gb or 16Gb FAT 32 FORMATTED.**

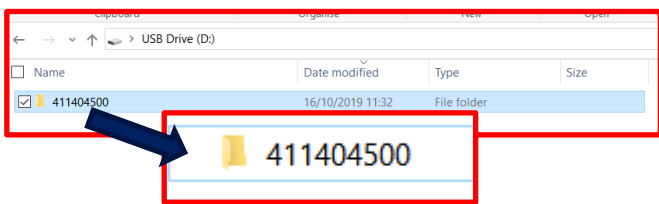

Appearance of the **P.P** when unzipped and locally saved on your USB key in root.

- Insert the freshly made USB key into the access USB port of the oven
- Follow instructions in how to enter into the § USB TRANSFER AMBIENT (SERVICE FUNCTIONS) with "service credentials "
- Enter into the "Upload selection"; select the **P.P** (411404500) that you have downloaded and saved into your USB key that you desire to transfer from the USB key into the oven UI and press 

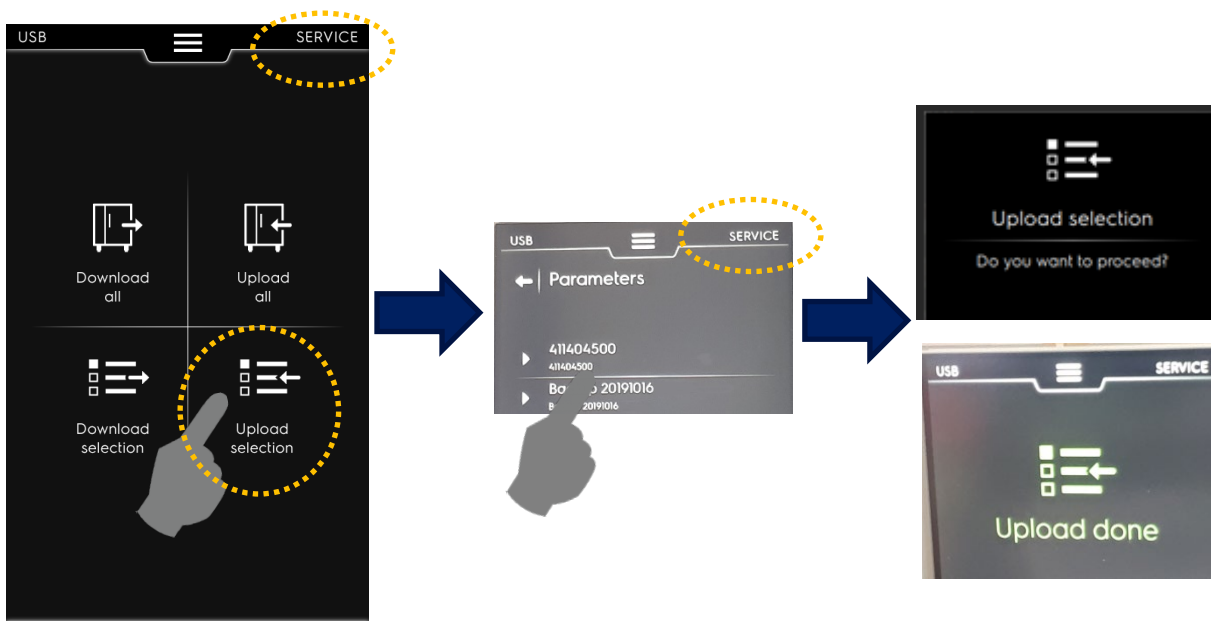



2.8.7 Pnc & ser upload (pncserial.json)

This is also the procedure to upload into a replaced spare part the PNC-SER § OVEN IDENTITY CARD that is needed for SKY DUO/CONNECTIVITY.

In case that we have to replace an user board (U.I) it will be necessary to upload into the new board the Programming file, Programming Parameters files (refer to previous chapters) and also upload the **PNC & SER**. The **PNC & SER** fields aren't filled in by the software installation when uploading **PF / PP** software

In the picture an example of identity card of a new spare part U.I installed. After **P.P** and **P.F.** upload, the **PNC & SER** will have not updated and will

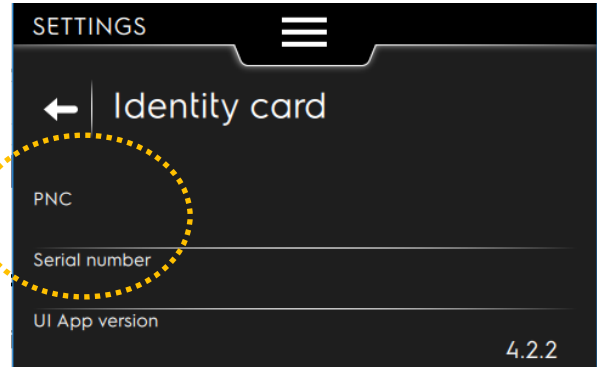

2.8.7.1 How to update pnc & ser (pncserial.json):

Located in the PRIDE web site, attached to the SERVICE MANUAL of the UNIT (DIGIT HE PNC) is located a file named **“pncSerial.json”**;

Document type	Service Manual	Factory	PDD - Pordenone
Document number	595403J00	Platform	Standard Benefit Ovens
Alias		Owner	PDD
Document edition	1.03	Supplier	
Description	ED 1.03 Service manual Skyline oven 6-10 Gas & JASON PNC-SER FILE	Class	C - OVENS
Date	26/07/2019	Family	14 - COMBI BOILERLE
Production status	In production	Type	D - 10 GRIDS 2/1
Distribution status	<input checked="" type="checkbox"/> In distribution	Created by	Fabio Ornella
Certificate type		Creation date	venerdi 26 luglio 2019 14:44:10
		Updated by	James Trevisan
		Updating date	venerdi 18 ottobre 2019 16:49:45

Language	File attach	Size (bytes)	Ins.date
Common	595403J00 SM SKYLINE GAS 6-10 ED 1.03.docx	41919982	26/07/2019
Common	595403J00 SM SKYLINE GAS 6-10 ED 1.03.pdf	25038590	01/10/2019
Common	pncSerial.json	58	18/10/2019



Double click to unzip and locally save the “**pncSerial.json**” into your USB key in the root. It is preferable to have the following USB type: **USB TYPE 2.0 8Gb or 16Gb FAT 32 FORMATTED.**

Be careful to MAINTAIN the extension “ pncSerial.json “ when you are saving the file to your USB key!!

It could be that the proposed name for the file has removed the “**.JSON** ” extension or replaced it with a “**TXT** extension”.... we need to keep the “pncSerial with” . “**.JSON** ” extension.

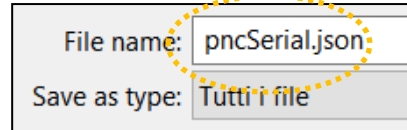
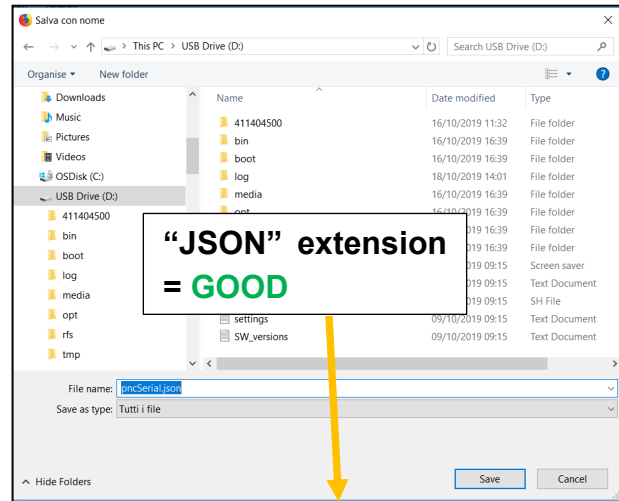
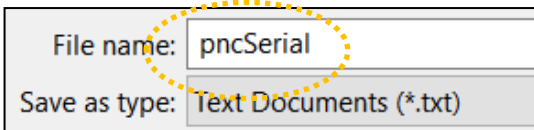
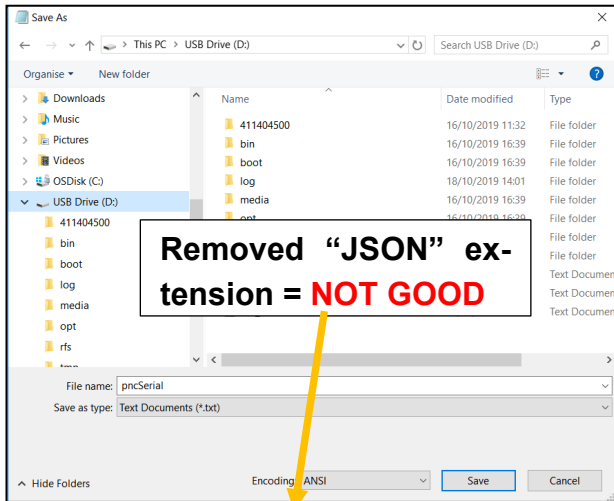

The correct appearance of the json file saved locally in your usb key.

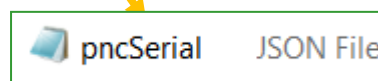
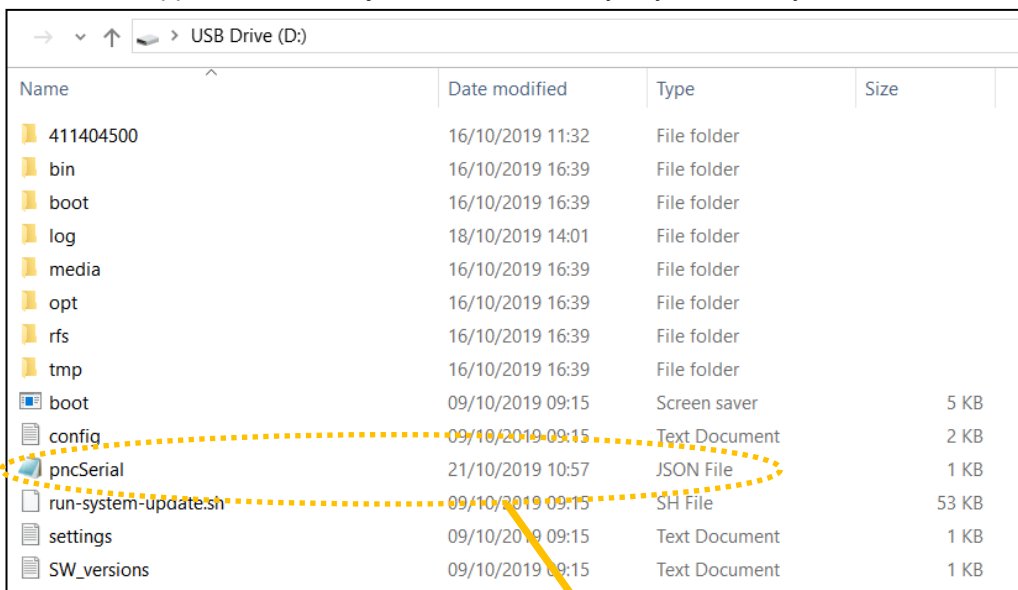



Once that the data has been inserted correctly save the file with the **“.JSON ”** extension back to the USB Key

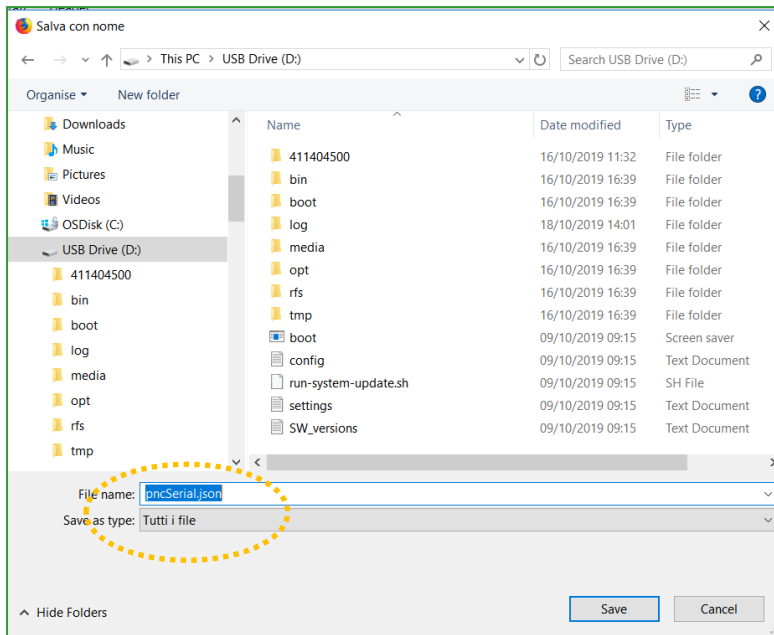

“JSON” extension = GOOD

File name: **pncSerial.json**
Save as type: Tutti i file

2.8.7.2 How to install update pnc & ser (pncserial.json):

With the oven turned on, insert your USB Key into the main port, enter into the § BY-PASS ENVIRONMENT:

1. Enter in the service area to activate the “Bypass” (not necessary for the oven-already activated)

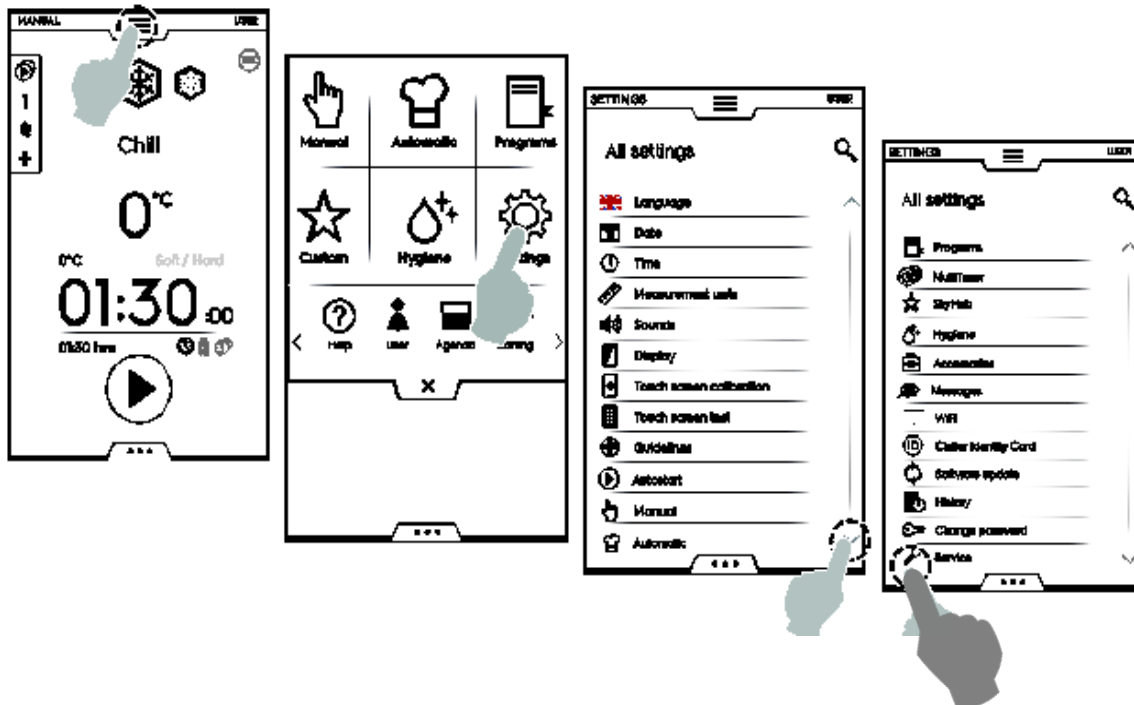



2. INFORMATION: Could be necessary to enter in the service area to digit a PASWORD that can guarantee to only specialized personnel access to this environment where can modify the actual setting.
3. The PSW IS 11235813.....
4. Back to main environment menu



5. Press the icon "Bypass" 1.
6. Insert the flash usb into the drawer of contro panel
7. Press the button "upload PNC-SN" in the screen of Bypass _For the oven press "LOAD"

PNC and SN has been updated successfully

8. At the end of upload will apper the label "Pnc & serial loaded" for the oven
9. Go back in envioment Skyduo as described in the paragraph "1.3 pairing status", and the pnc will present.

Crosscheck that the **PNC and SER** have been written into the identity card by enetering into the § SETTINGS , accessible in the main screen view by pressing the menu drop down menu. The access of this area does not require a password.

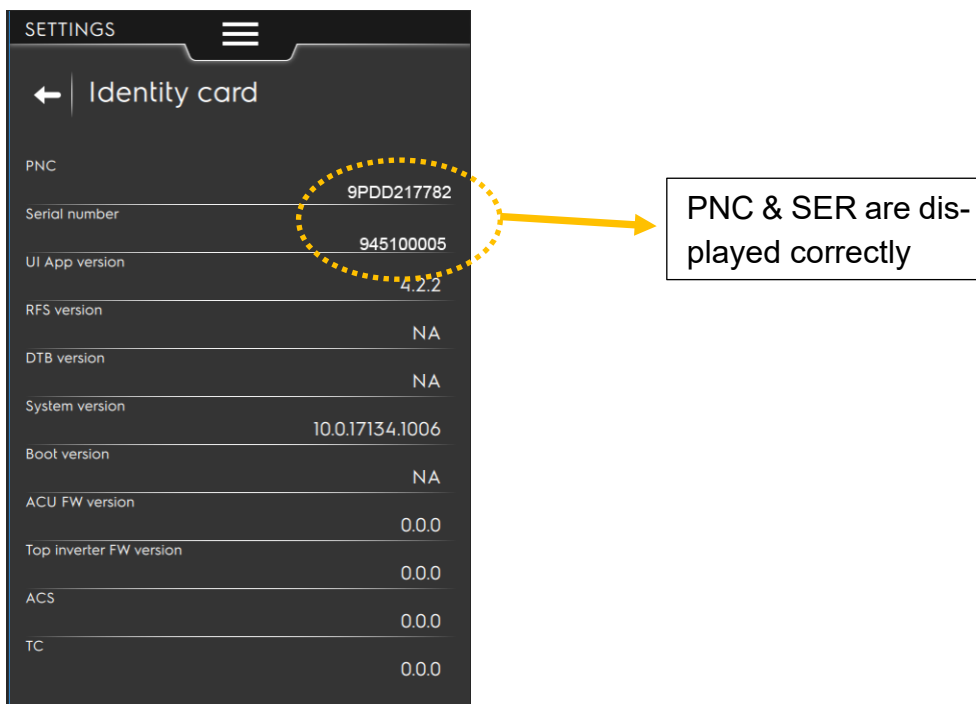



2.8.8 Usb data transfer

The Transfer ambient is used to manage data transfer between UI and a USB key. It contains four functionalities:

- Download all: Used to copy all data (parameters, recipes,...) from UI to USB key;
- Upload all: Used to copy all data from USB key to UI;
- Download selection: Used to select, from a single category (parameters, recipes,...), which items to copy from UI to USB key;
- Upload selection: Used to select, from a single category, which items to copy from USB key to UI.

The navigation will be the same for the generic user and the Service user, but the effects on the download/upload operations will be different.

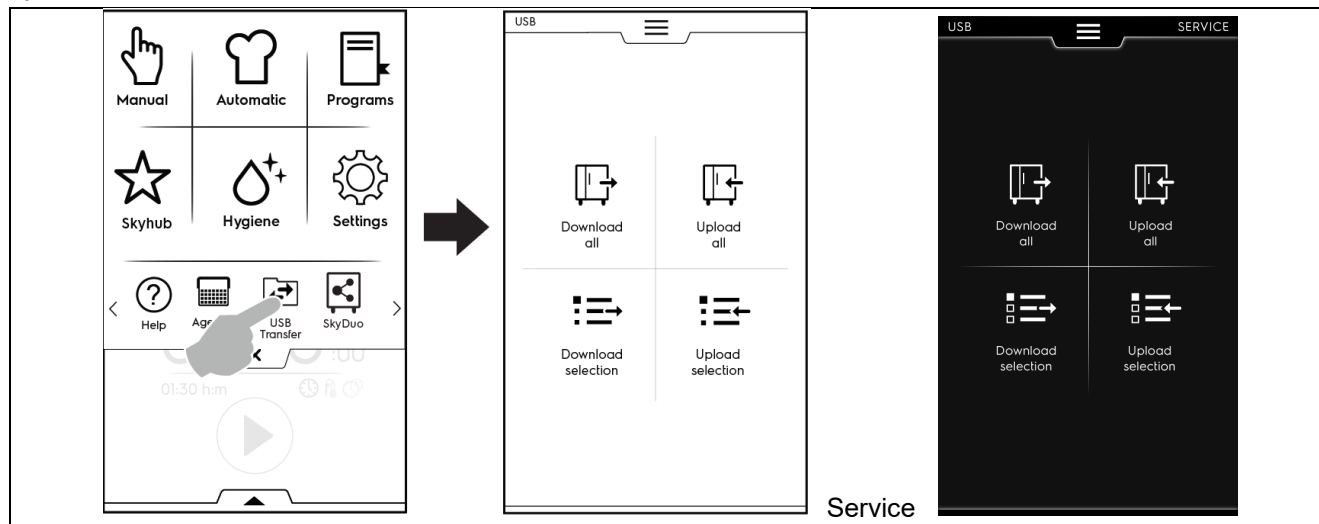

2.8.8.1 Users management lite

Only two user profiles will be available on the first functionality release: “User” and “Service”.

“User” will be the default profile, “Service” will be accessed through password on the Settings->Service menu. Once the password is correctly entered the “Service” credentials will be active for 15 minutes while navigating the interface. The 15 minutes timeout is continually reset while the appliance is in running state and every time the interface detects a touch. If the “Service” credentials are active, there has to be a “logout” button in the secondary menu in the upper drawer to force the switch from “Service” to “User” credentials.

With “Service” credentials the user interaction will differ for the following points:

- 1) The download/upload functionalities will include Service parameters, including size and other characteristics related to the machine model. Anyways, the user will receive a warning popup while changing these parameters.
- 2) The download functionalities for logs will include additional logs for debugging or post-mortem analysis purposes.
- 3) In running state the user will have access to the top drawer. Only the data monitor button will be active.
- 4) The user will have full access to Service parameters setting and data monitor.

The user knows if “Service” credentials are active because on the top right of the screen will be visible the “SERVICE” label. If “User” credentials are active, the space will be left blank.

2.8.8.2 What follows is a diagram to show menu navigation

1. LOG IN as SERVICE following the procedure” **HOW TO ACCESS TO SERVICE AREA**”
2. Go back in the enviromente main menu
3. Select the USB folder
4. The display showed the functionality of Download or Upload



What follows is a description for each of the pages:

2.8.8.3 Select types

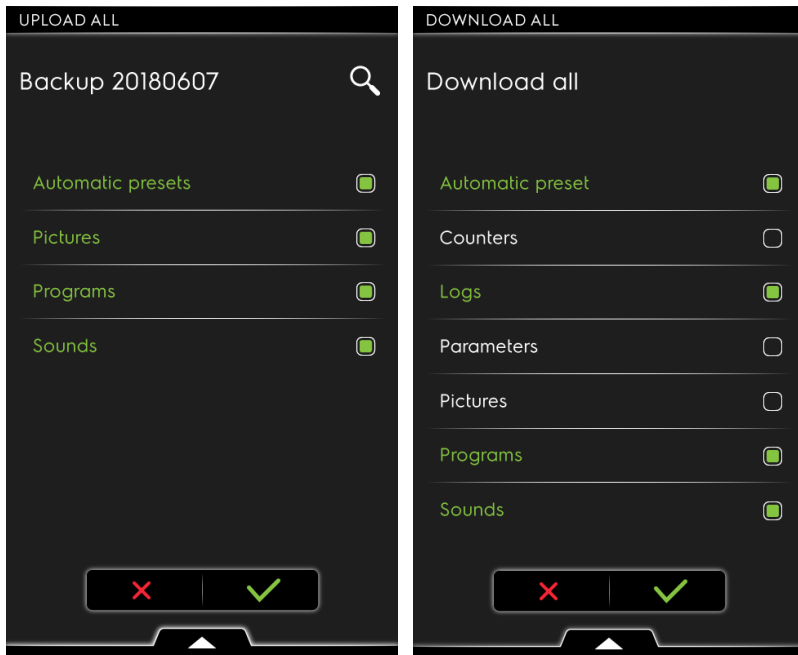

In the download all and upload all functionalities, the user can choose which data to include in the download or upload operation:

In case of an upload operation, only the types present on the USB key will be present in the list.

2.8.8.4 Select type

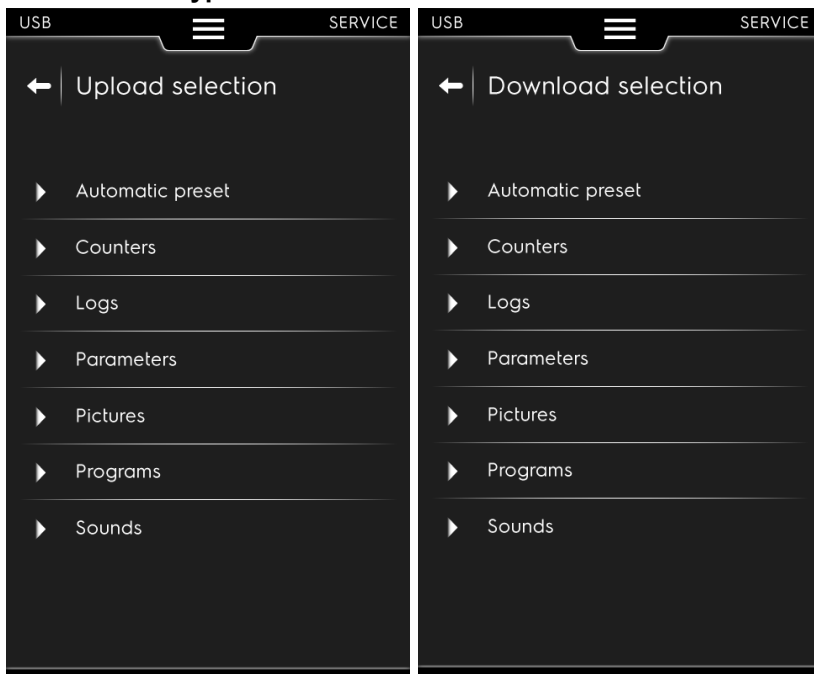

In the download selection and upload selection functionalities. It is similar to paragraph 1 (select types), but the user can only choose a type from a list:



2.8.8.5 Select file

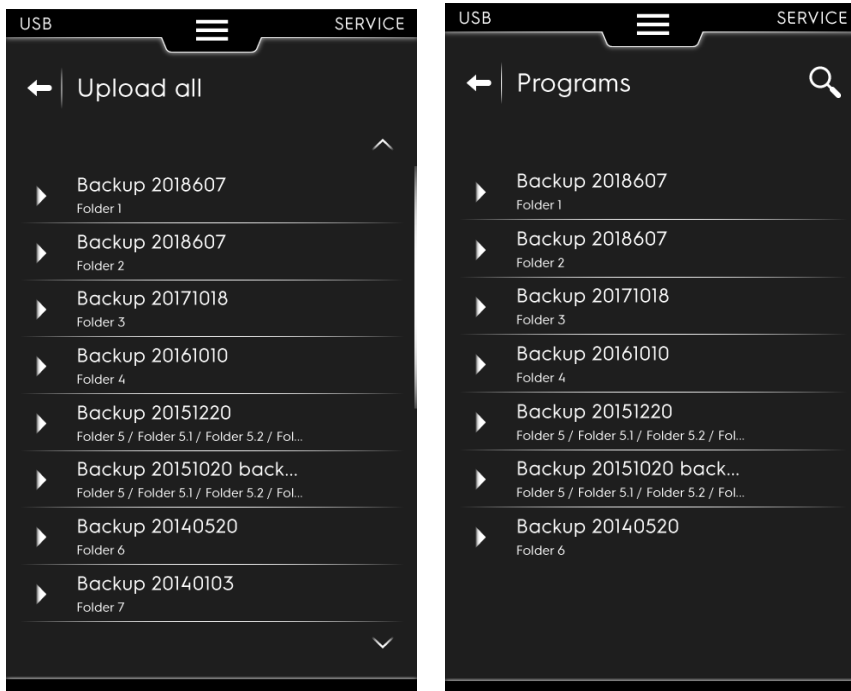

It is present for all of the upload functionalities. The user can select a file for upload operation. On the bottom of the file name there is the file path displayed, unit excluded.

2.8.8.6 Select file or add new file

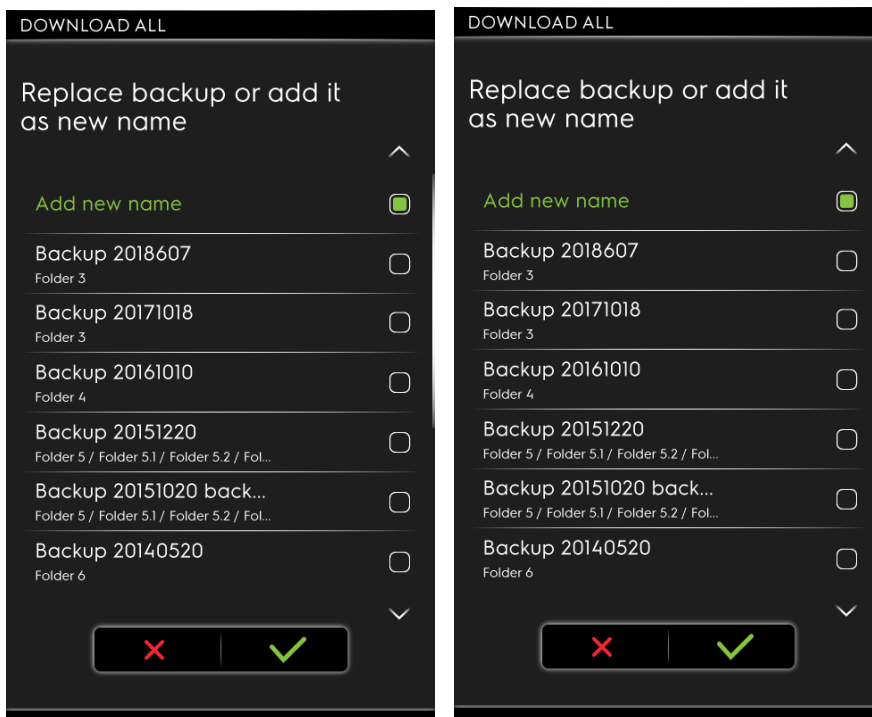

It is present for all of the download functionalities. The user can select a file to overwrite, or create a new file.



2.8.8.7 Enter file name

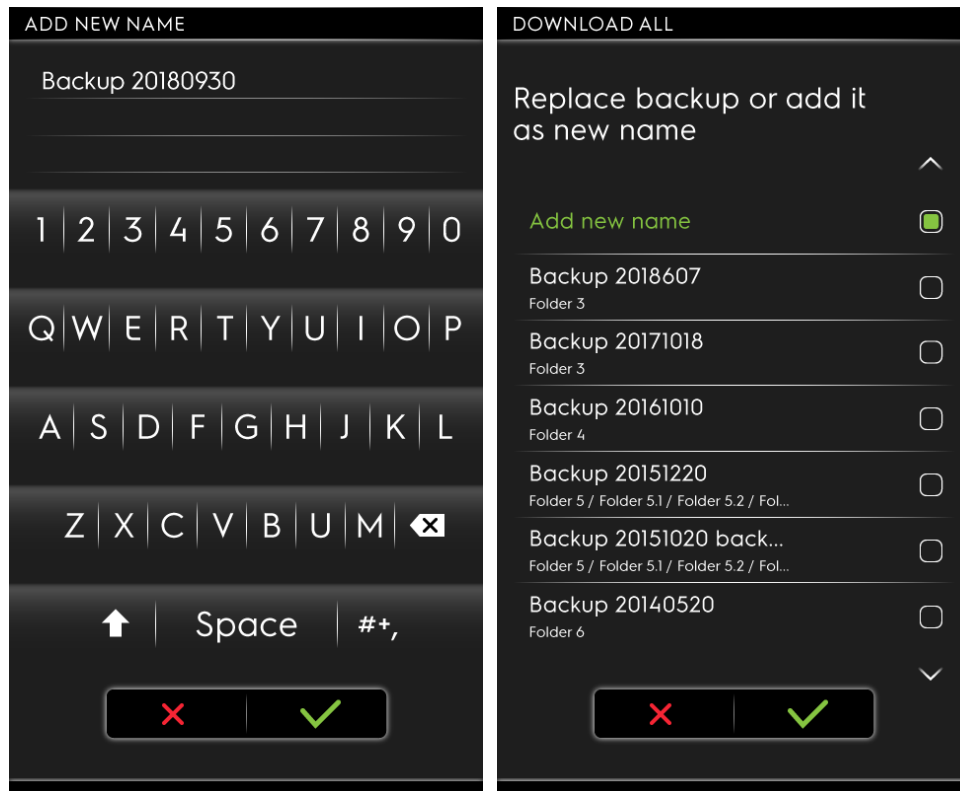

Enter a name for the file being created.

2.8.8.8 Select Items

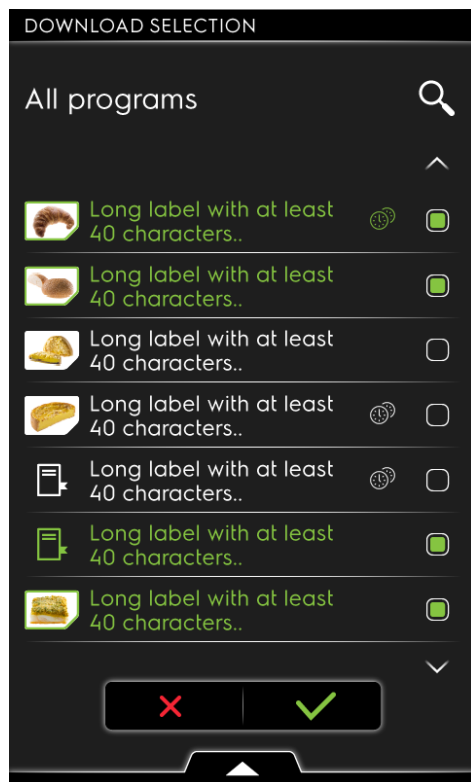

In the download selected and upload selected functionalities, it is used to select which items to copy from/to the USB key.



2.8.8.9 Confirm

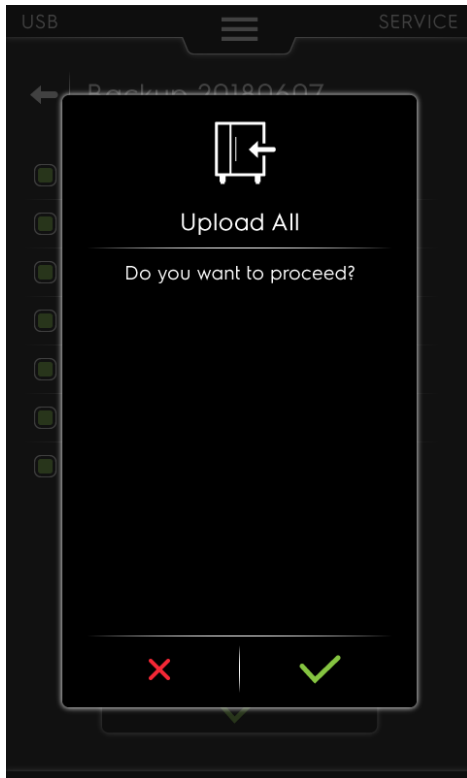

A confirmation popup used to acknowledge a file overwrite on USB key or on the UI (symbols and texts differ for different operations).

2.8.8.10 Replace or add items

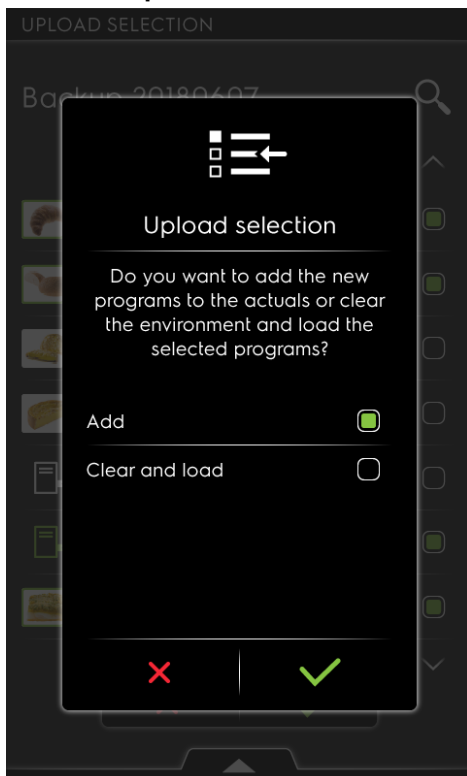

In the upload selected functionality, it is used to specify if the items selected have to replace the existing items or they should be added.



2.8.8.11 Skip, Duplicate, Add

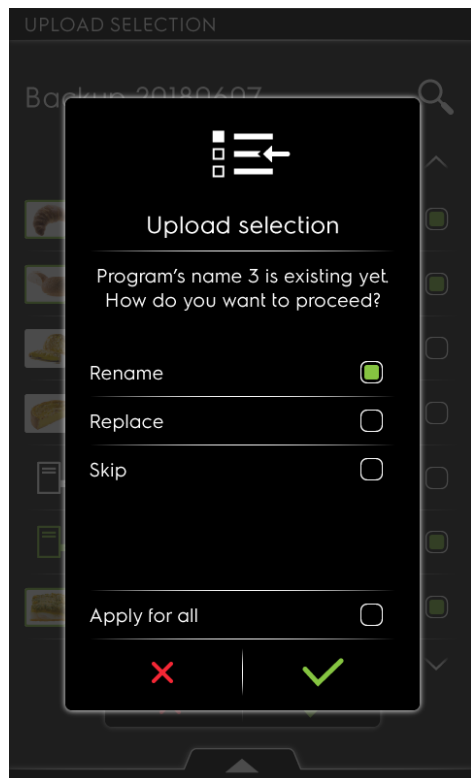

When the user is importing items from USB, this page is displayed if there are items with the same name on the UI. For each of the items, the user can choose to keep the existing item (skip), to replace it with the new one (Replace) or to duplicate it (Duplicate). In the page there will be a checkbox to apply the operation for all of the remaining items.

2.8.8.12 Enter item name

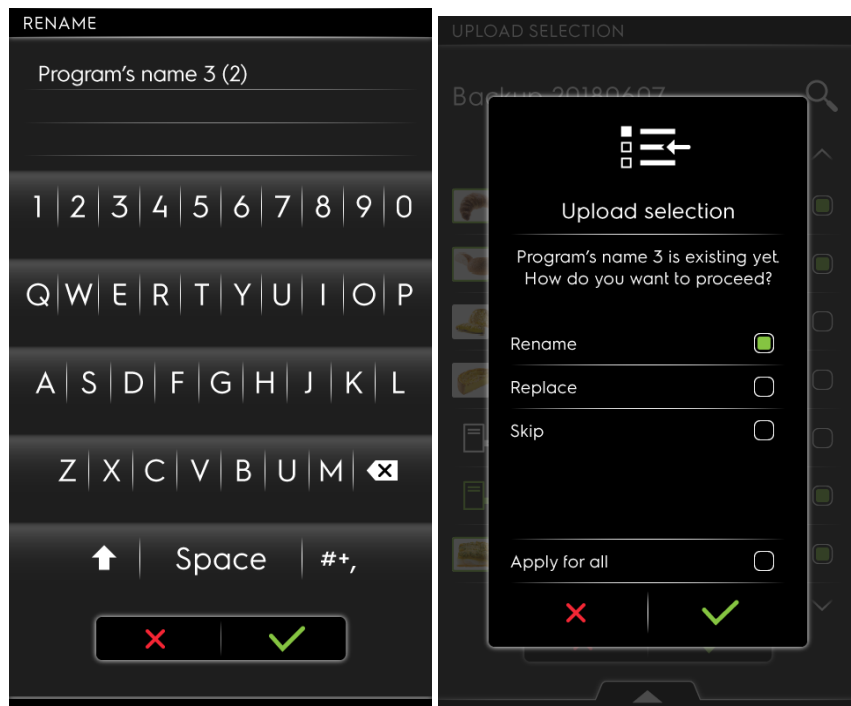

It is similar to paragraph 5 (Enter file name), but it is used to specify an item name instead of a file name. It is reached only from paragraph 9 (Skip, Duplicate, Add), if the user chooses Duplicate.



2.8.8.13 Types list for service:

Type	Selectable in download/upload selected	“Replace” and “Add” available in “upload selected”	Only download	File extension
Programs	✓	✓		.prg.json
Automatic presets	✓	✓		.apres.json
Parameters				.par.json
Sounds	✓	✓		.snd.tar
Pictures	✓	✓		.img.tar
Logs	✓		✓	.haccp, .fsc(*), .alm.json
Counters			✓	.cnt.json

(*): only electrolux

2.8.8.14 File names

When downloading files to USB, if new files are being created, the user can choose the file name, but there will be a default file name in the page, that he can confirm or modify.

The user will be allowed to edit the filename without extension. The appropriate extension will be added automatically.

The default filename will be related to the current timestamp:

<yy><mm><dd><hh><nn>.<ext>

Where .ext is taken from the type list table.

2.8.8.15 Item names

In paragraph 5 (Enter item name), the user will be prompted to edit the item name or accept directly the default name. The default name will derive from the originating item name, appending the string “_2” at the end of name, before the first dot.

2.8.8.16 Errors and Warnings:

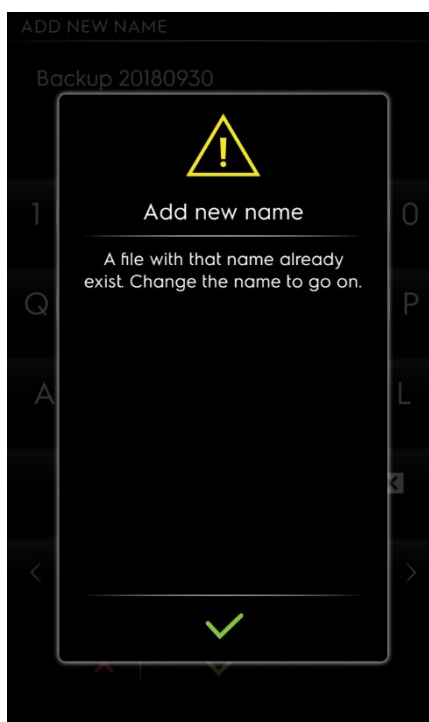

Error and warning layout example:



The popup shown in the example above is an example for errors and warnings related to USB management. The simple above will be a yellow triangle for warnings and a red cross for errors. The icons used will be the same of the “diagnostics” section.

For Download operations, when, after entering the main download page, the green Tick is pressed but no USB key is detected yet.

For Upload operations, when pressing one of the two download buttons in the main screen, a wait of N seconds should be applied before showing the popup. If before N seconds the USB is detected, the UI should open immediately the menu selected. If the N seconds elapse, the popup should be displayed.

N should be determined performing some tests with various USB Keys, to minimize false alarms and limit the wait.

(**) <item> can be Agenda, Programs,... according to row “type” in the type list table

Writing operations on UI

When writing data on the UI, special care must be taken when data is being overwritten. The implementation has to manage the operation so that if it is interrupted (e.g. because of a power failure) the old data will be kept.



2.8.9 How to access to service area

Service Area

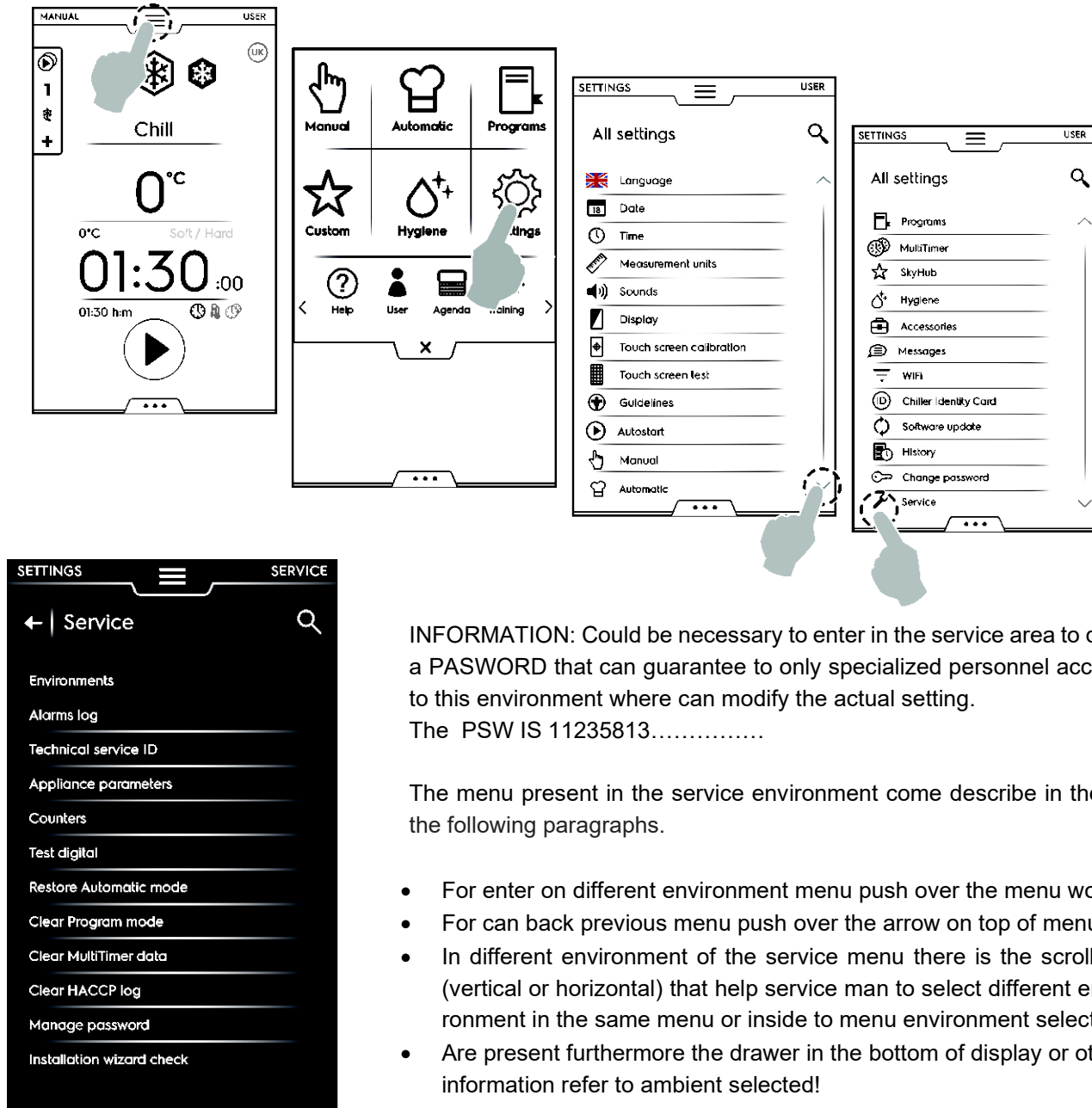

INFORMATION: Could be necessary to enter in the service area to digit a PASWORD that can guarantee to only specialized personnel access to this environment where can modify the actual setting.
The PSW IS 11235813.....

The menu present in the service environment come describe in the in the following paragraphs.

- For enter on different environment menu push over the menu word!
- For can back previous menu push over the arrow on top of menu!
- In different environment of the service menu there is the scrollbar (vertical or horizontal) that help service man to select different environment in the same menu or inside to menu environment selected!
- Are present furthermore the drawer in the bottom of display or other information refer to ambient selected!



2.8.9.1 How to show the “data monitor”

- Enter in the service area as show the chapter 2.8.9
- Back to the main menu window
- Select in the sub menu “data monitor”

2.8.9.2 How to exit from “data monitor” and “bypass”

- Enter in the main menu window
- Select in the sub menu “service log out”

2.8.9.3 How to enter in “bypass”

- Enter in the service area as show the chapter 2.8.9
- Back to the main menu window
- Select in the sub menu “Bypass”

2.8.9.4 How to upload the pnc and serial number

- MAKE SURE THAT YOU HAVE UPLOADED THE .JSON FILE WITH ITS PNC AND SERIAL NUMBER TO BE UPLOADED TO A USB STICK
- Enter in service area as show the chapter 2.8.9
- Select the icon “Bypass” as described the chapter 2.8.9.3
- Insert the “usb stick”
- Select in the screen of bypass the ROW “Upload PNC-SN”
- The automatic upload will start
- In the event of a load fault, which occurred as a message in the display, repeat the procedure, or check the extension of the loaded file is correct or the data entered in the file is correct.

2.8.9.5 How to upload the parameter and interrogation

- MAKE SURE THAT YOU HAVE DOWNLOAD THE ZIP FILE .PAR FROM WEB RELATIVE TO PNC
- UNZIP THE FILE AND UPLOAD THE FOLDER IN TO A USB STICK (the folder must be contain the file – par.json and .PDF)
- **Note : the .PDF file is only used for read the parameter upload in case to interrogation manually parameters)**
- Enter in the service area as show the chapter 2.8.9
- Back to the main menu window
- Select in the sub menu “USB Transfer” as described in the chapter” 2.8.8 USB DATA TRANSFER.”
- Insert the USB stick
- Select the upload selection
- Automatically the name of the folder inserted in the usb will appear in the display
- Confirm the Upload with green arrow
- After uploading remove the usb stick
- In the event of a load fault, which occurred as a message in the display, repeat the procedure, or check the extension of the loaded file is correct or the data entered in the file is correct



2.8.9.6 Service ambiente explanation

2.8.9.6.1 Enviroment

Select/deselect the ambient showed in the main menu

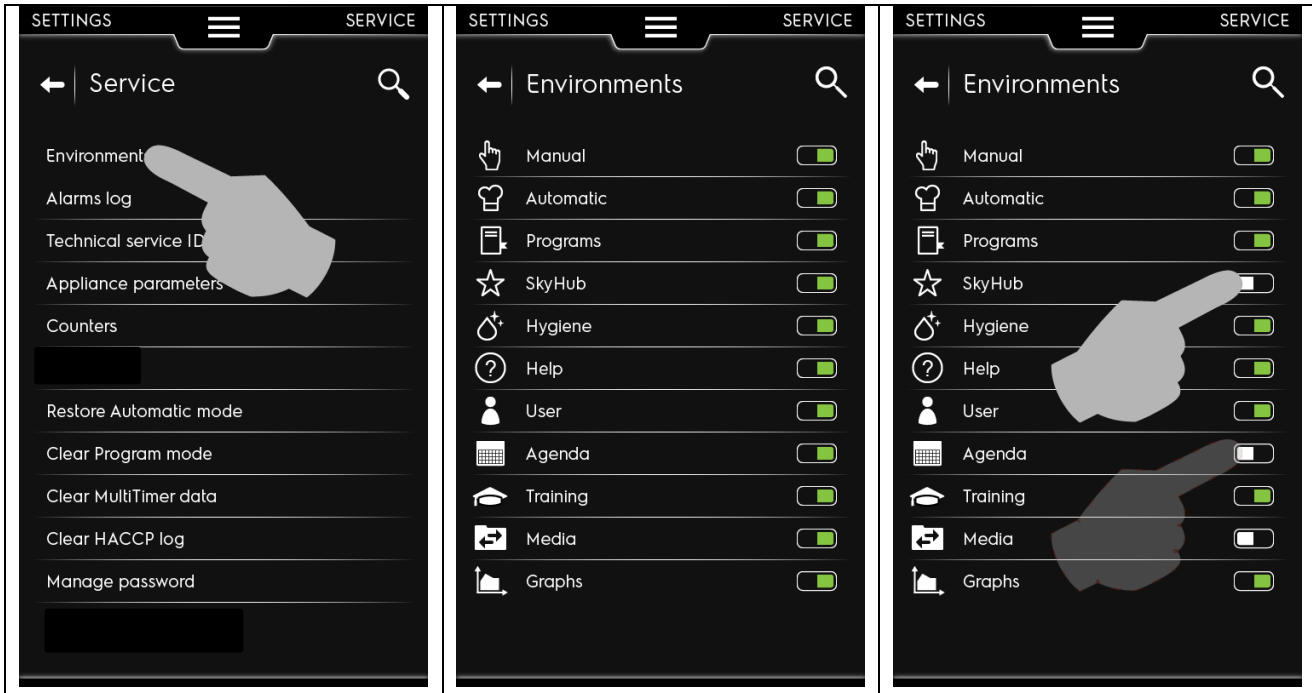

2.8.9.6.2 Alarms log

Show the history alarm

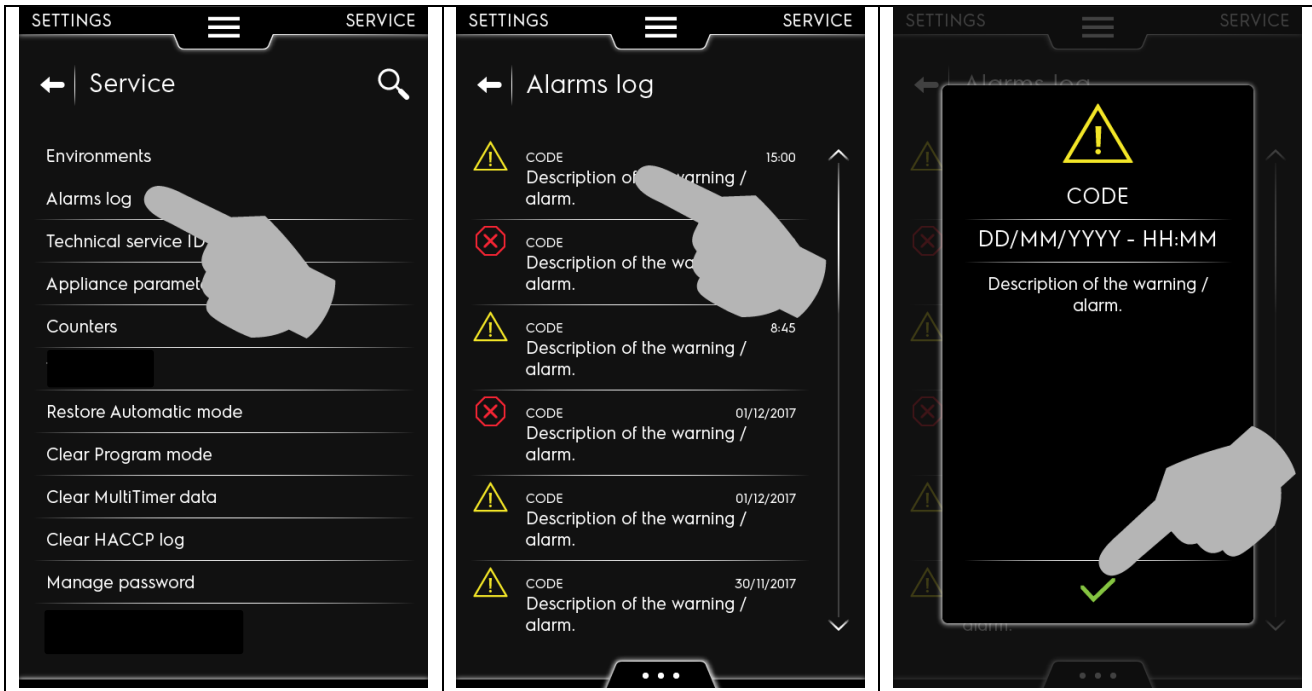



2.8.9.6.3 Technical service ID

Identification area of the technical service and phone number

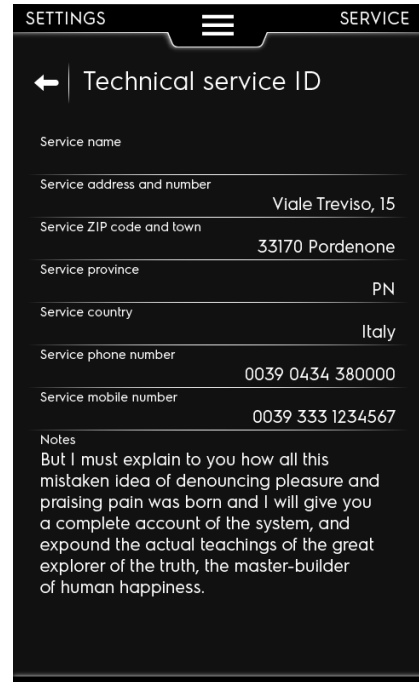
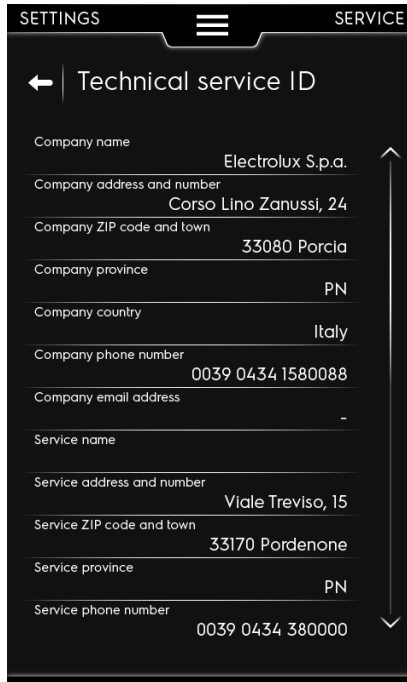
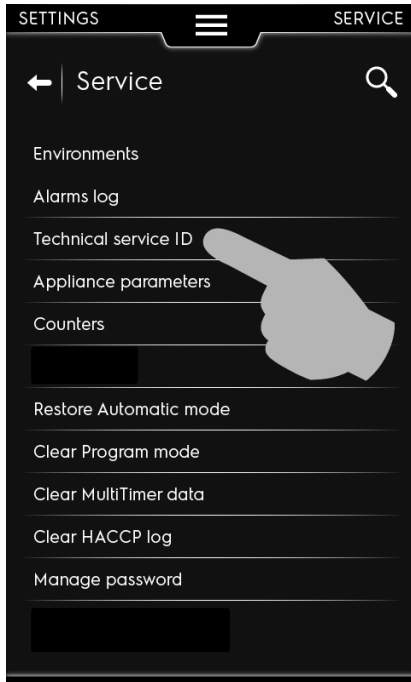

2.8.9.6.4 Appliance parameters

- Identification of parameter and value to set or change.
- Reset the default parameter setting

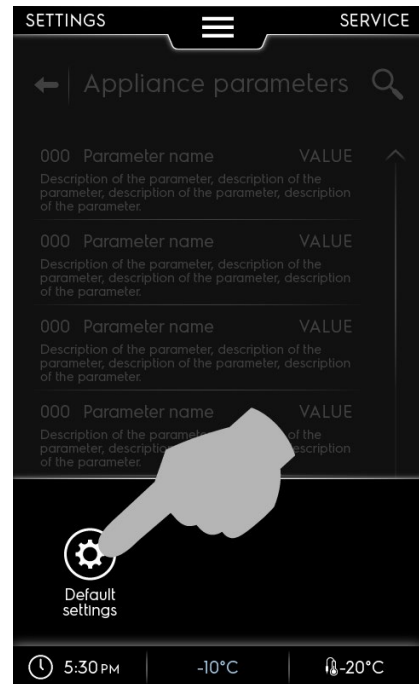
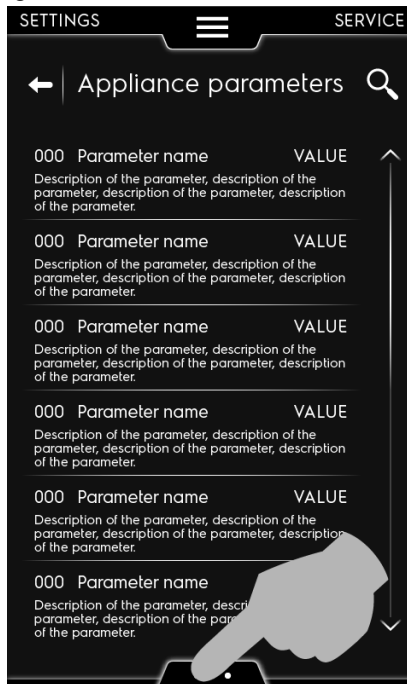
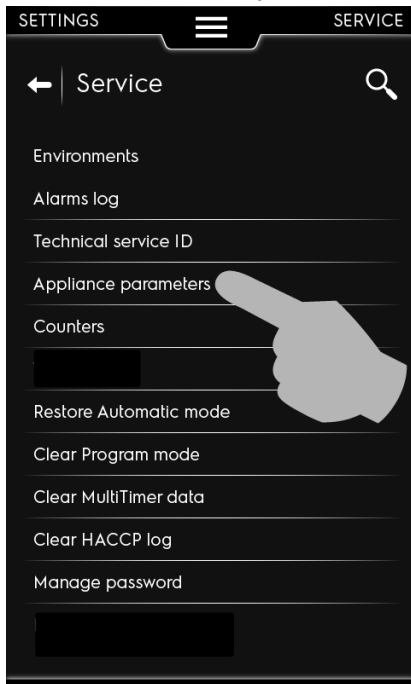



2.8.9.6.5 Counters

Here it is possible check the time and cycle used in the units, as:

- How many cycle used
- How many hours used
- Reset the counter

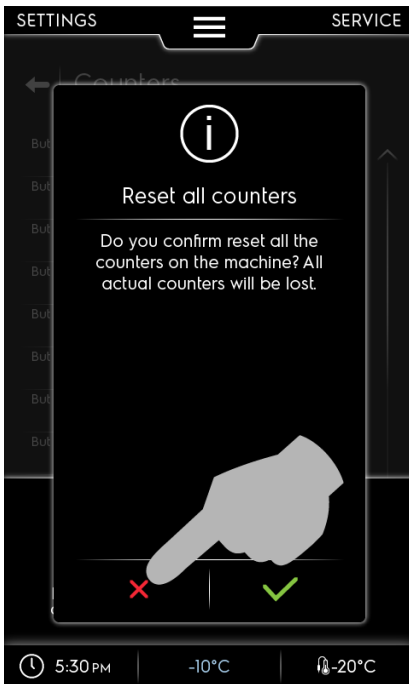
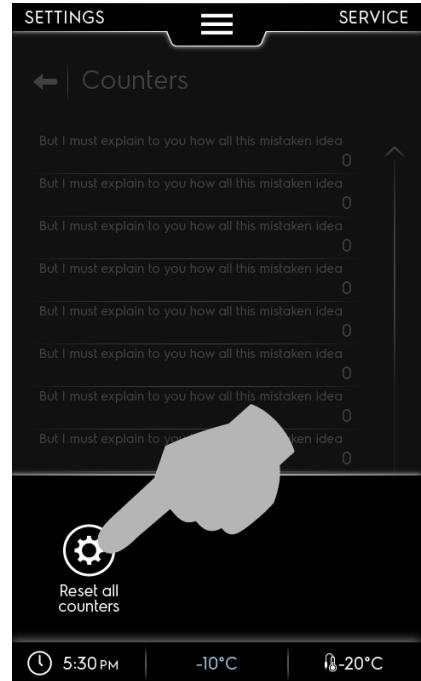
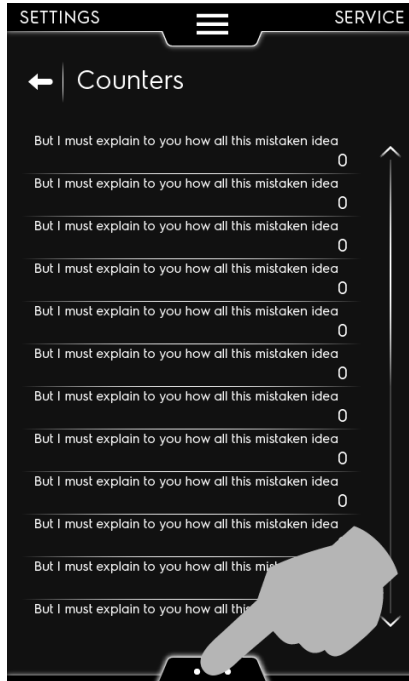
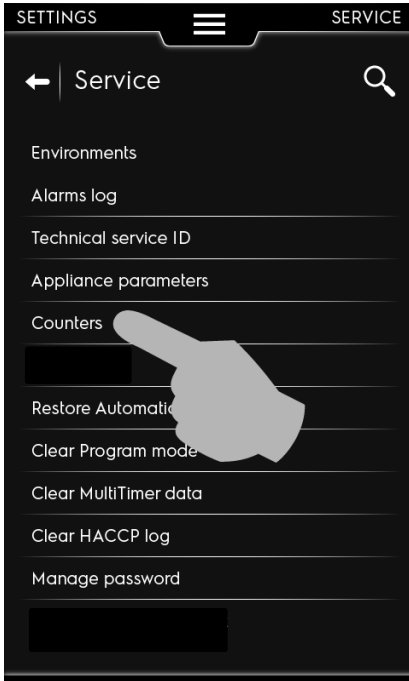



2.8.9.6.6 Test digital I/O

Check of the functioning for each component (ON – OFF)

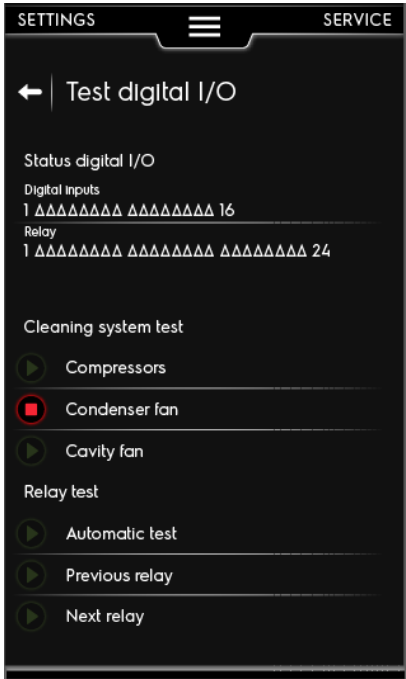
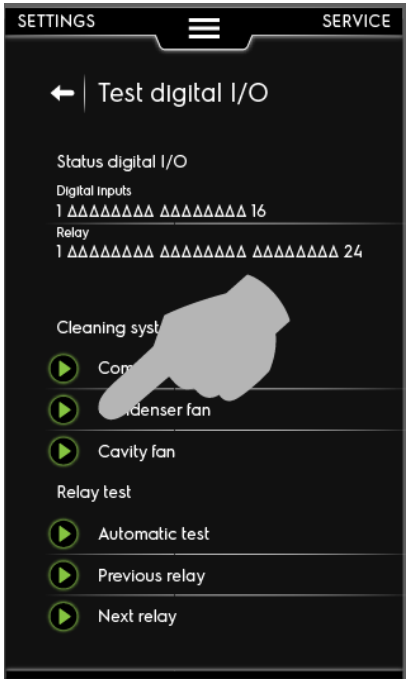
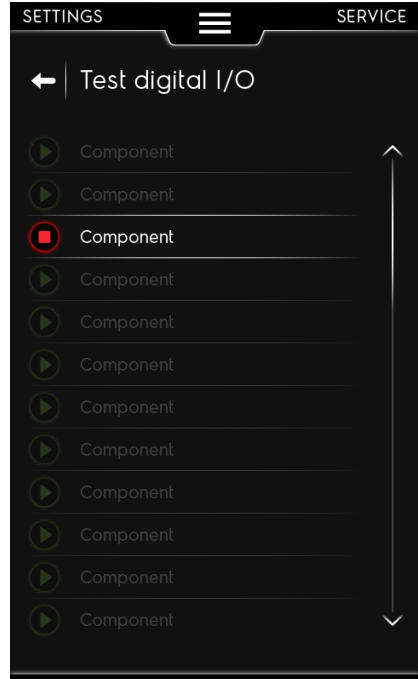
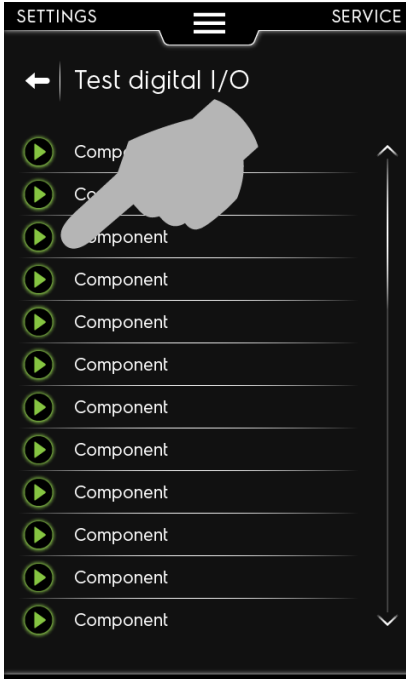
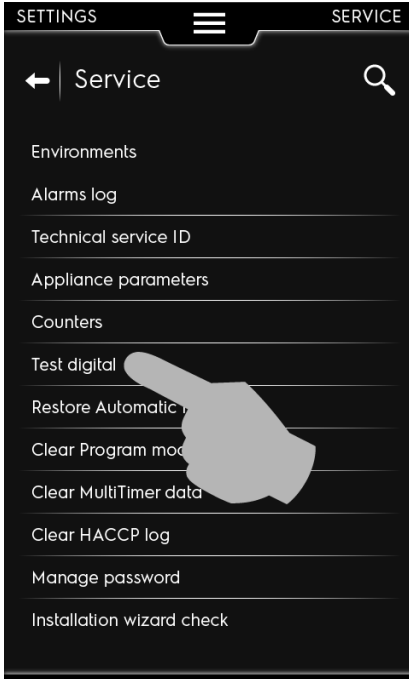



2.8.9.6.7 Restore Automatic mode

Cancel and restore the original automatic cycle factory preset. (Once selected all user presets will be lost)

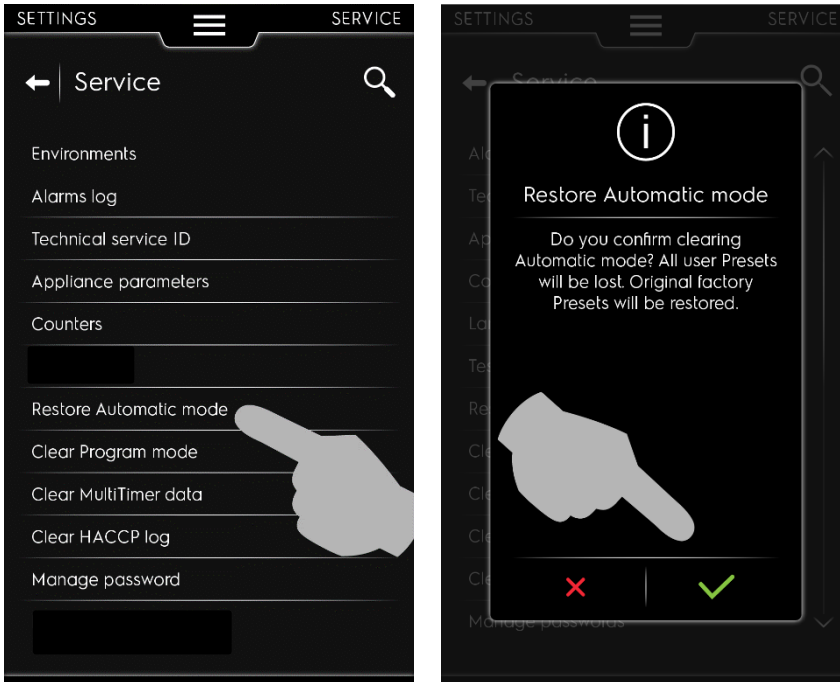

2.8.9.6.8 Clear Program mode

Cancel all program and categories set from user.(Once confirmed all information will be lost)

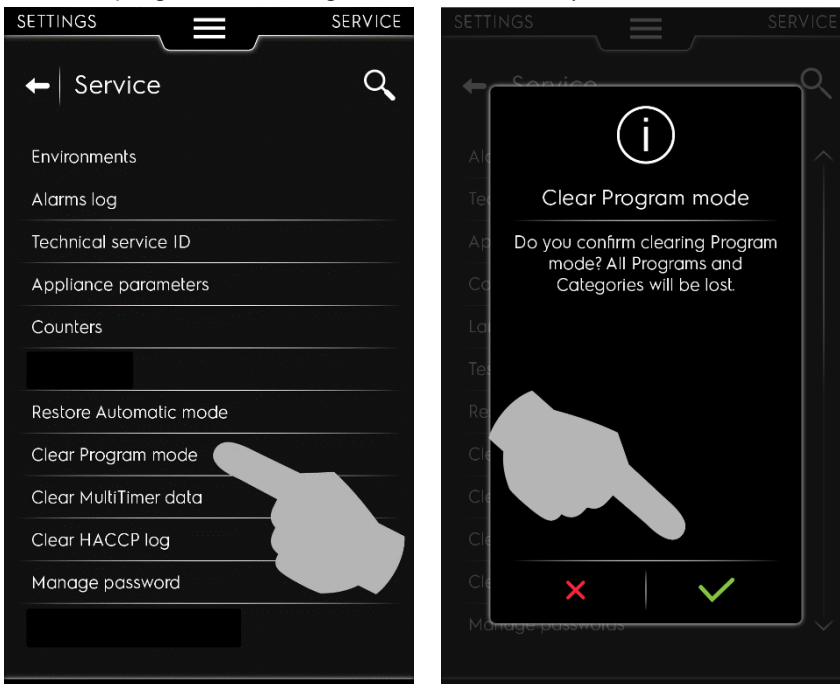



2.8.9.6.9 Clear MultiTimer data

Cancel all MultiTimer data

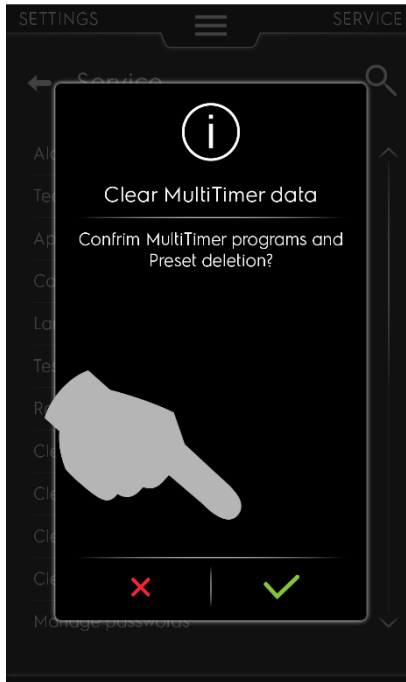
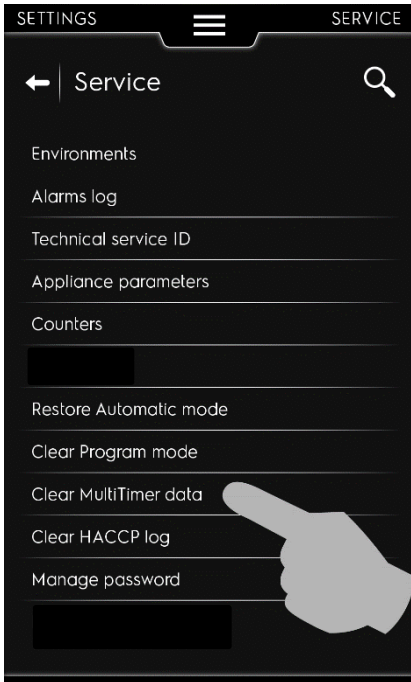

2.8.9.6.10 Clear HACCP log

Cancel all HACCP log

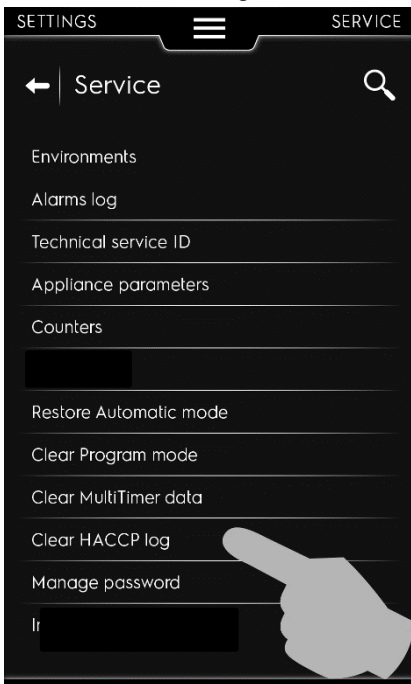



2.8.9.6.11 Manage passwords

Reset the password of user in case it is lost or forgotten

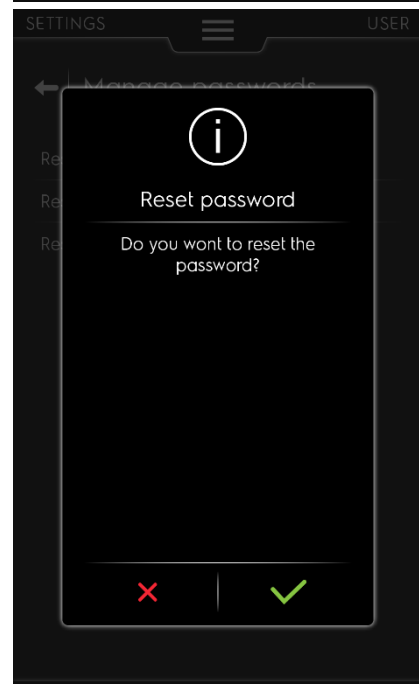
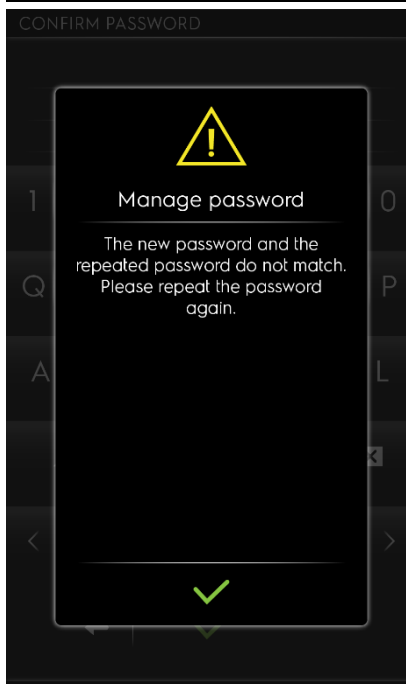
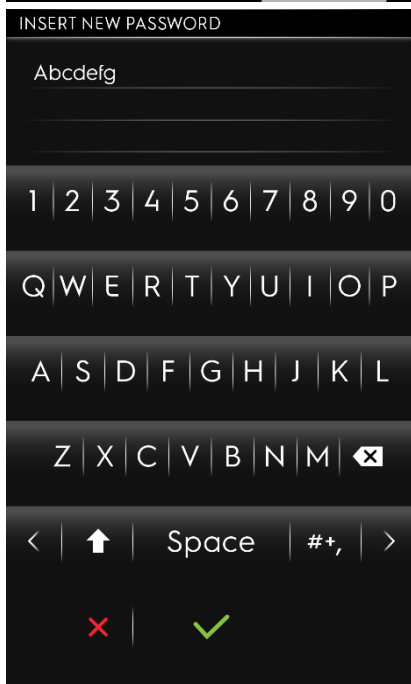
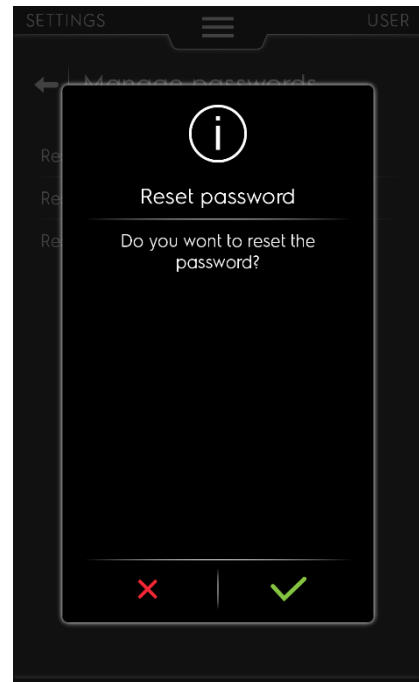
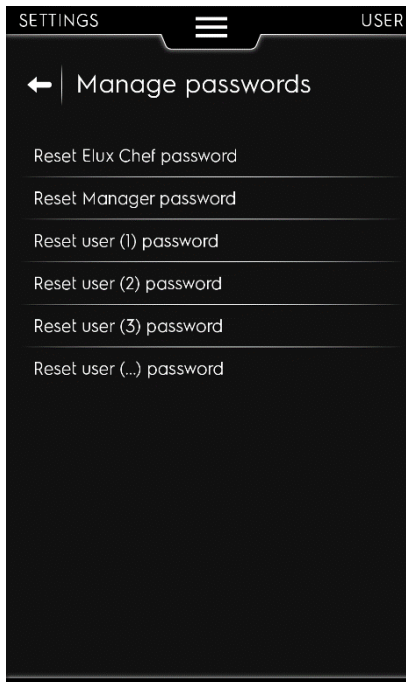
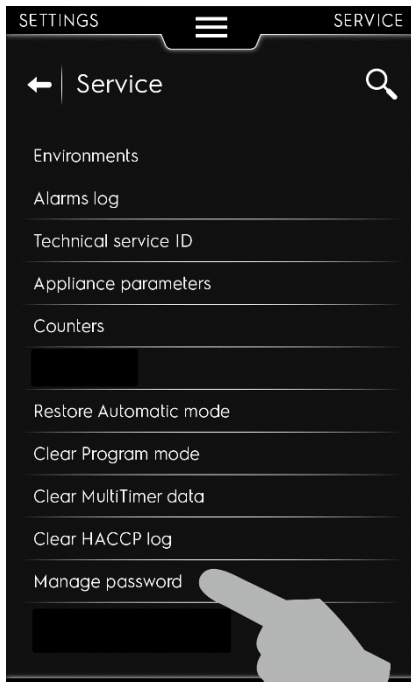



2.9 WIZARD

2.9.1 Installation wizard check

Automatic test of the unit , with relative setting of date and time and check all components and probes

If the wizard is enabled, from parameter **LAIP**, at first switch on of the unit the wizard will On .

It is mandatory for first Installation, and consecutive test of components or cycles, for further checking of components and unit. There will be 3 step mandatories to do , and they can't possible to jump. At the end of testing the unit will store the process and will be store the result on the memory of the unit.

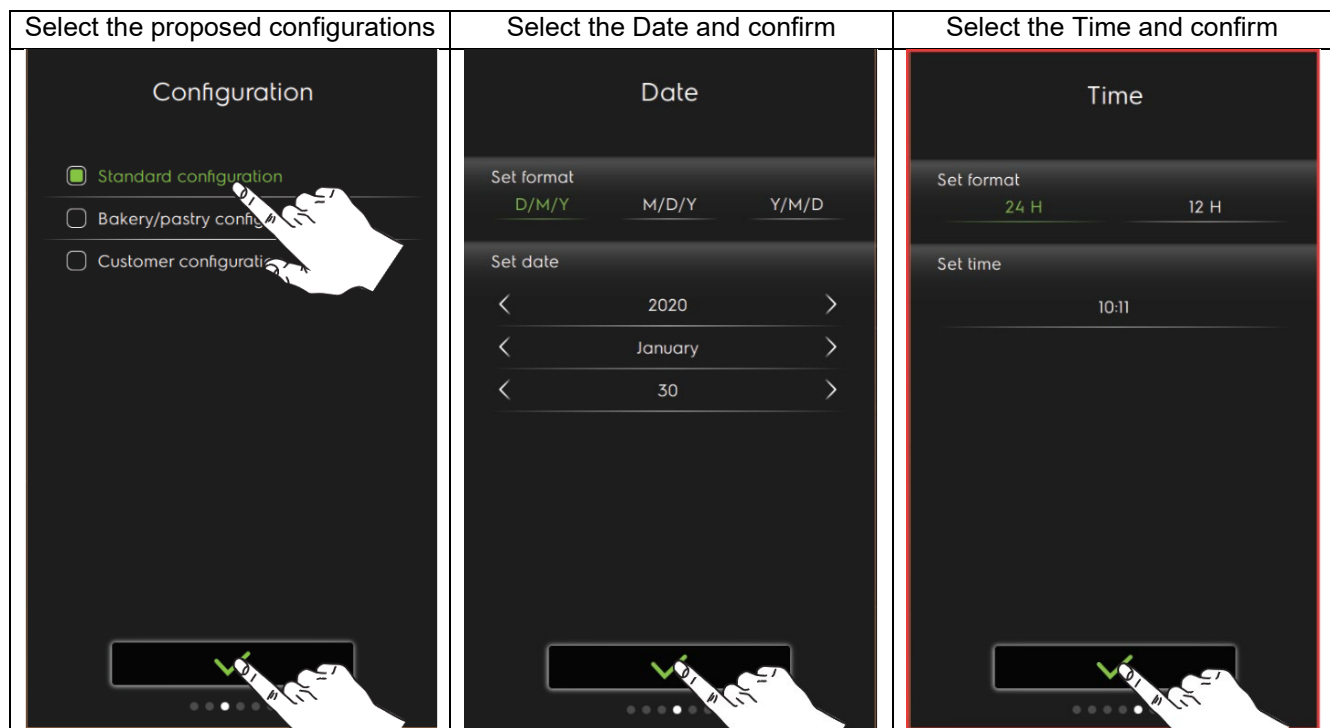
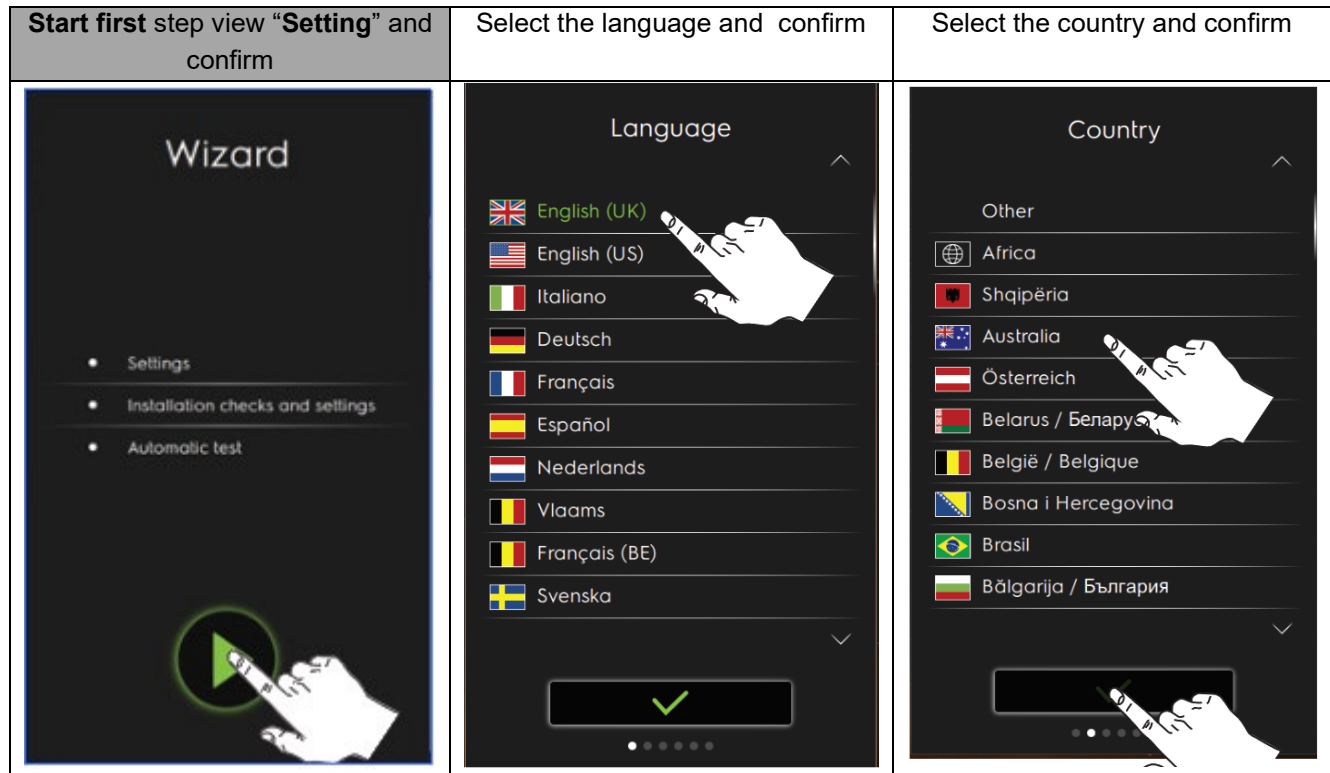





<p>Select the Measurement and confirm</p>	<p>Start Second step “Installation checks and setting” view and confirm</p>	<p>Control fan rotation, Amp_Volt and confirm</p>
<p>Measurement units</p> <p>Temperature</p> <p>°C °F</p>	<p>Wizard</p> <p>✓ Settings</p> <ul style="list-style-type: none"> • Installation checks and settings • Automatic test 	<p>Power supply</p> <p>Check the electric connection of all the phases Check the correct rotation of cavity fan connected to 400V. Respect the MCA (Minimum circuit ampacity) for wiring cables and MOP (Maximum overcurrent protection) for fuse. Verify the overcurrent protection.</p>

<p>If the unit is connected to a water-cooled condensing system, check the points described, and confirm</p>	<p>Control the leveling of the unit and in case adjust the gasket and door, where it is possible, and confirm</p>	<p>Install the guides, check the correct position of the structure for pastry or gastronorm pans</p>																					
<p>Condensing unit water connection</p> <p>This step applies only to the appliances with water connection. Check the water temperature, the flow direction and the pressure according to the table below. Clean the flow valve.</p> <table border="1"> <thead> <tr> <th>H₂O</th> <th>min</th> <th>max</th> </tr> </thead> <tbody> <tr> <td>*C</td> <td>10°</td> <td>40°</td> </tr> <tr> <td>*F</td> <td>50°</td> <td>104°</td> </tr> <tr> <td>bar</td> <td>1.5</td> <td>3</td> </tr> <tr> <td>Psi</td> <td>21.7</td> <td>43.5</td> </tr> <tr> <td>*H</td> <td>7</td> <td>14</td> </tr> <tr> <td>*dH</td> <td>4</td> <td>8</td> </tr> </tbody> </table>	H ₂ O	min	max	*C	10°	40°	*F	50°	104°	bar	1.5	3	Psi	21.7	43.5	*H	7	14	*dH	4	8	<p>Positioning</p> <p>Level and adjust door and the gasket door</p>	<p>Levelling</p> <p>Verify the correct levelling of the tray rack.</p>
H ₂ O	min	max																					
*C	10°	40°																					
*F	50°	104°																					
bar	1.5	3																					
Psi	21.7	43.5																					
*H	7	14																					
*dH	4	8																					

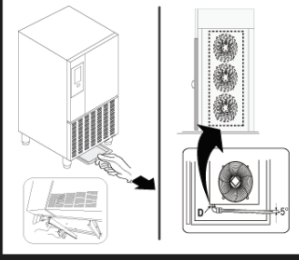



<p>Install the condenser water tray and discharge water condensation pipe (if necessary where present), and confirm</p>	<p>Start Third step view “Automatic Test” and confirm</p>
<div style="background-color: #333; color: white; padding: 10px;"> <h3 style="text-align: center;">Condensate tray or drain installation</h3> <p style="text-align: center;">Fit the condensate tray support guides with the condensate tray or connect the drain hole to a water flow drainage system.</p>   </div>	<div style="background-color: #333; color: white; padding: 10px;"> <h3 style="text-align: center;">Wizard</h3> <ul style="list-style-type: none"> ✓ Settings ✓ Installation checks and settings • Automatic test  </div>

A compressor test will be activated for a specified time, if interrupted, with the stop button, it will remain inactive until the time that appears on the screen expires.

Together with the compressor, **one of the two condenser fans will also be active(range 30 50 70 kg)**; for clarification, the one opposite direction of the compressor position, will be active.

The other information available are: status of the door (opened or close), current sensor of the components activated (mA)

Once the component test is interrupted, the green signal will be signaled to in the same line of the component activated. If you want to repeat the component test, just press the start button again.

<div style="background-color: #333; color: white; padding: 10px;"> <h3 style="text-align: center;">Test digital I/O</h3> <ul style="list-style-type: none"> ▶ Compressor ✓ ▶ Condenser fan 1 ▶ Liquid valve ▶ Door heater ▶ Heaters ▶ Evaporator fan <p style="text-align: right; font-size: small;">Load timeout (sec): 0 Door status: Close Current sensor (mA): 0 Evaporator fan speed (rpm): 0</p> <div style="text-align: center; margin-top: 10px;">  </div> </div>	<div style="background-color: #333; color: white; padding: 10px;"> <h3 style="text-align: center;">Test digital I/O</h3> <ul style="list-style-type: none"> ▶ Compressor ✓ ▶ Condenser fan 1 ▶ Liquid valve ▶ Door heater ▶ Heaters ▶ Evaporator fan <p style="text-align: right; font-size: small;">Load timeout (sec): 0 Door status: Close Current sensor (mA): 0 Evaporator fan speed (rpm): 0</p> <div style="text-align: center; margin-top: 10px;">  </div> </div>
--	---



Test condenser fan 1. The condenser fan in same direction of the compressor will be active

Test liquid valve: The solenoid valve will be active. “ if present more solenoid valve , in the dash-board will be numerated (1,2, etc.)

Test Door Heater: The frame door heater will be active; it is possible test checking the current sensor, value

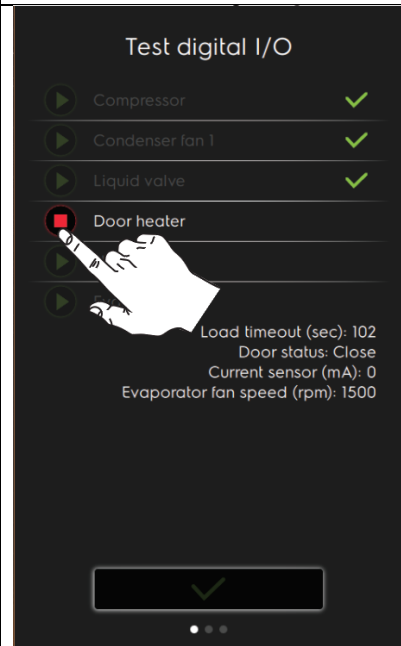
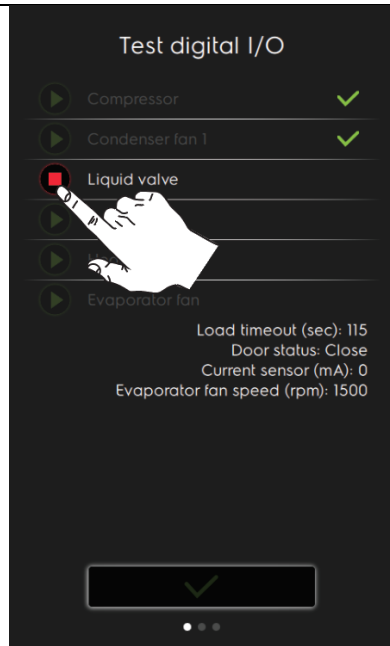
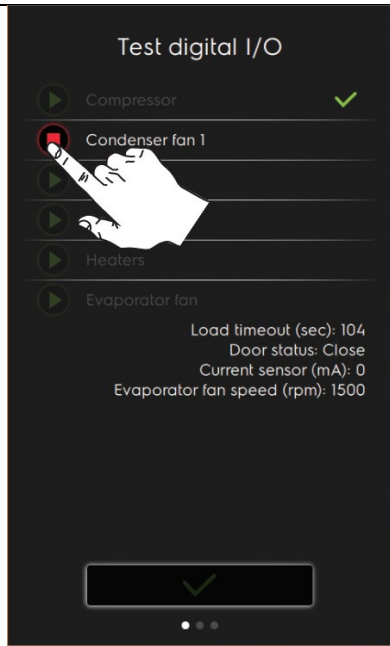

Test the Heaters: the heaters present in the evaporator, for defrost and hot cycle will be active. For correct diagnostic , check the value , “current sensor (mA); the value can change if there are one or more heaters present in the evaporator following the range of the unit. (usually one heater has 3470 mA) 800 W/230V

Test Evaporator fan: The cavity fan(s) will be active for maximum speed. Check for correct rotation, or any outages in the fans.

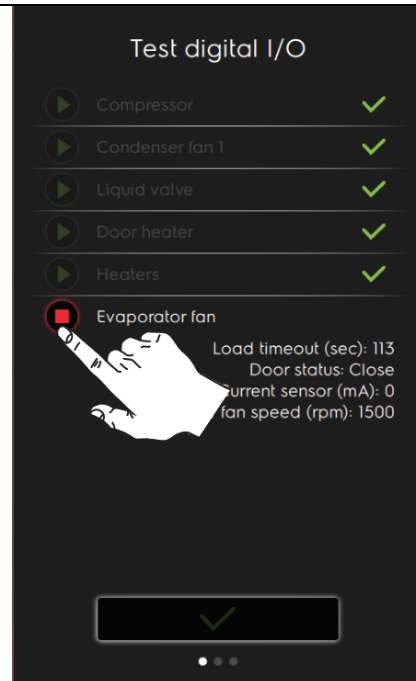
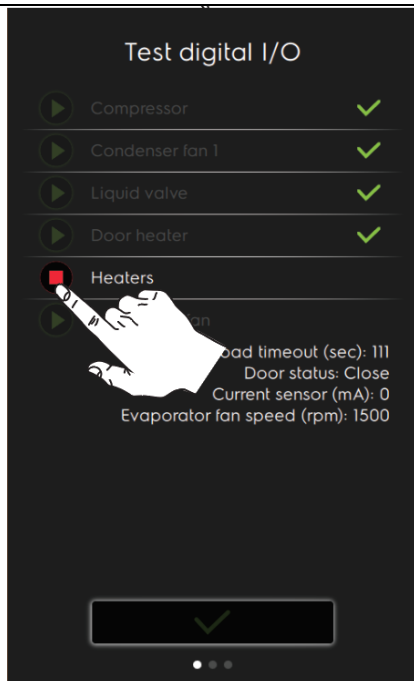



The digital test of the mechanical components has been done. Press the button to access next step (cycle testing)

Heating Unit Test: The hot cycle phase testing, it is necessary to check the proper cycle operation; Press the button and the cycle start.

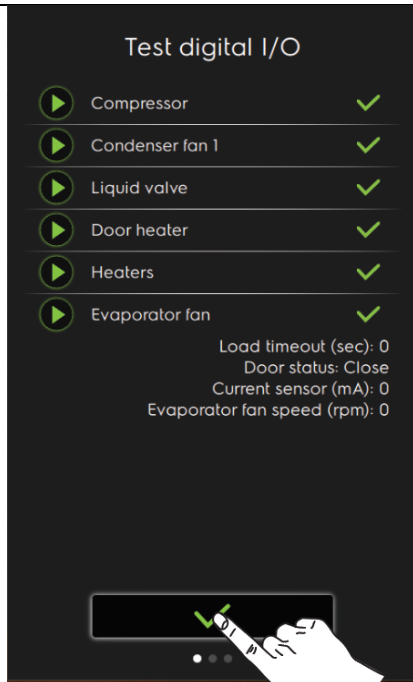

In the dashboard “Status” is indicated the first Step “Preparing phase”

The “**Preparation phase**” will end only when the temperature set in the “Cavity set” is reached.

The screenshot below shows the actual temperature of the cavity

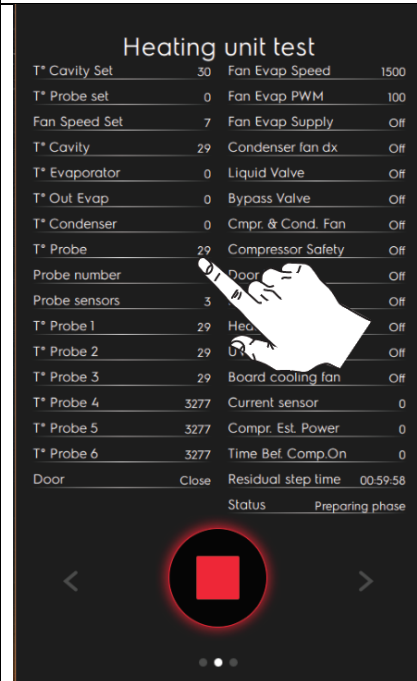



When the temperature of the “Preparation phase” is reached, the “Testing phase” is activated.

The temperature that must be reached at this stage is 40°C, which is shown in the line "T° Cavity Set".

A countdown time limit will be activated, which will determine the effective duration of the test; If the cavity temperature is reached before the time expires, the test cycle will end successfully

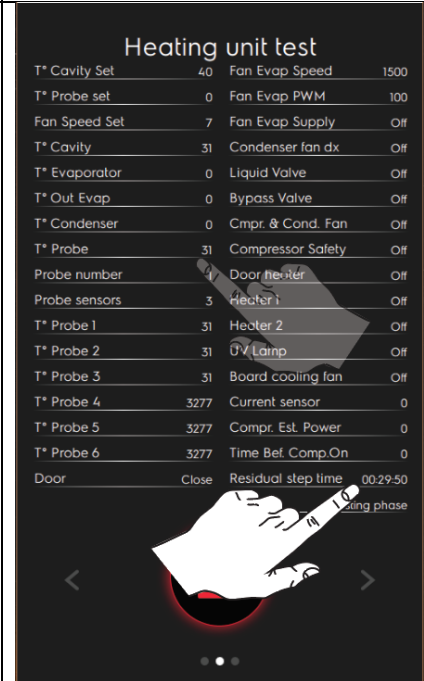
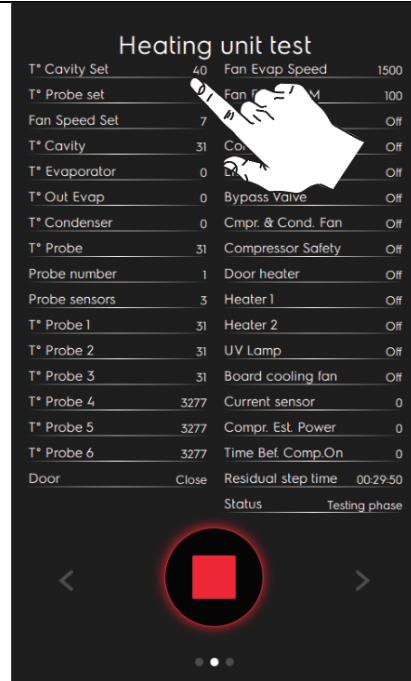
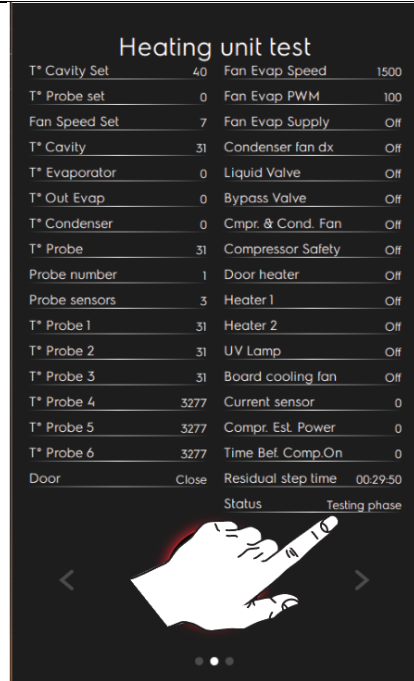

The screenshot below shows the correct phase concluded.

Cooling Unit Test: The cooling cycle is necessary to determine the correct functioning of the thermodynamic circuit and components, and overall correct presence of the refrigerant, where, if necessary, use the correct approach to set valves, (thermostatic, or pressostatic). Press the button and the cycle start.

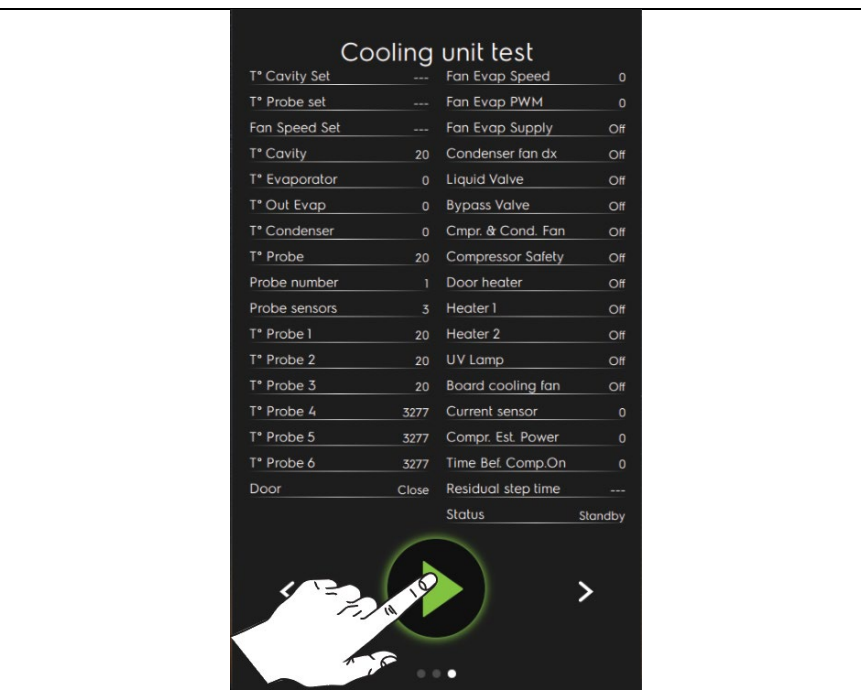
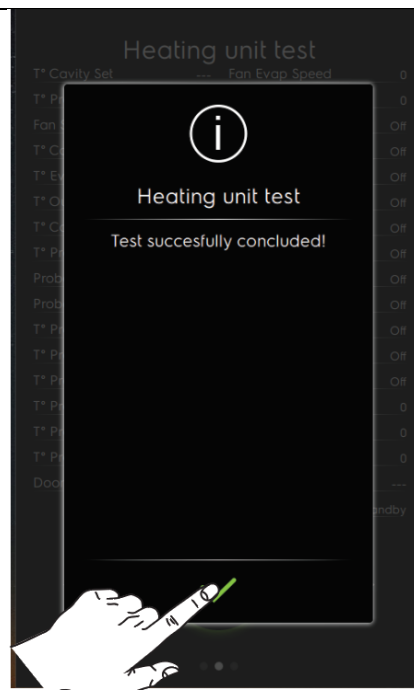



In the dashboard “Status” is indicated the first Step “**Preparing phase**”

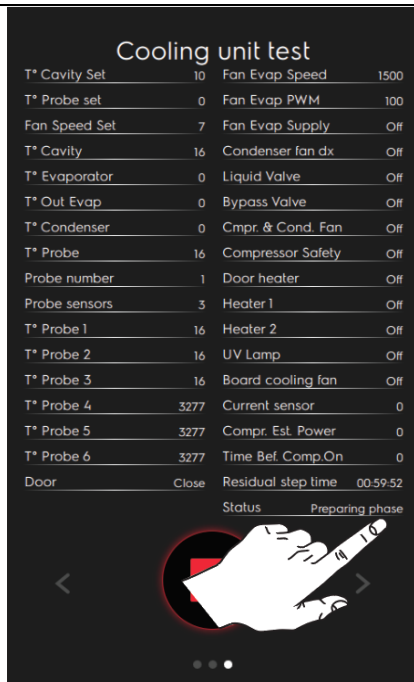

The “**Preparation phase**” will end only when the temperature set in the “**Cavity set**” is reached.

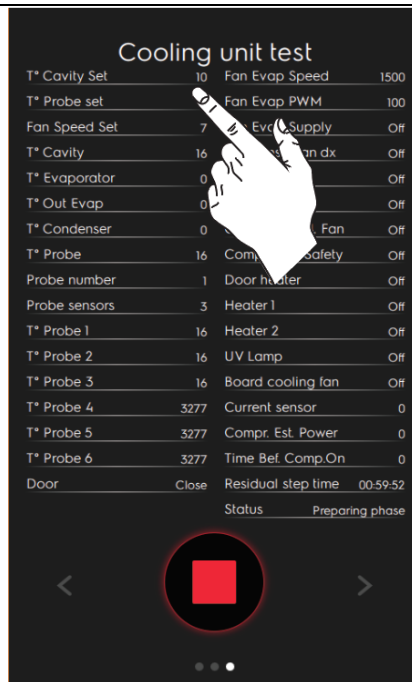

The screenshot below shows the actual temperature of the cavity

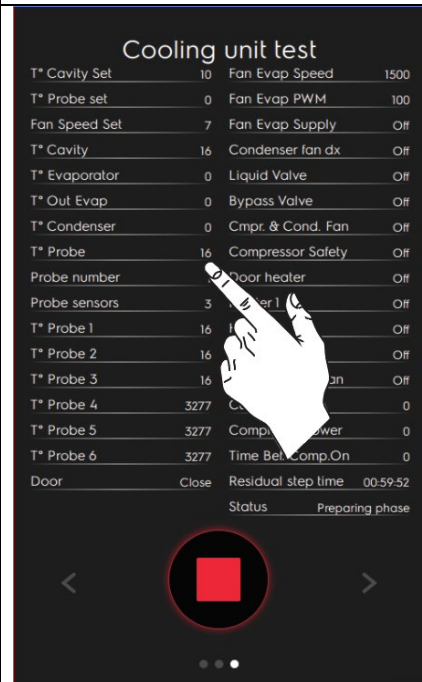

When the “Preparation phase” temperature is reached, the “**Testing phase**” is activated.



The temperature to be reached at this stage is -30°C, is shown in the line “T* Cavity Set”.

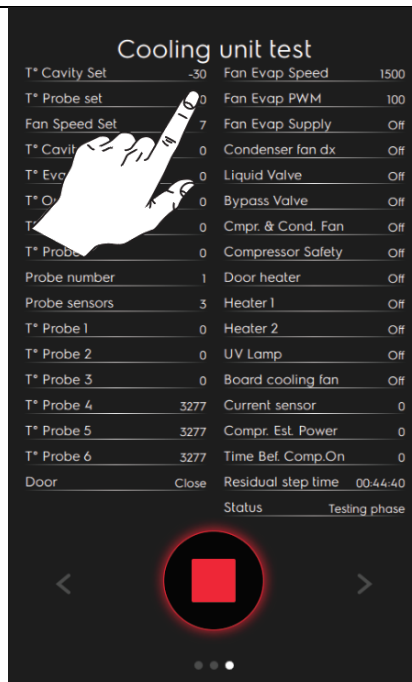

A countdown time limit will be activated, which will determine the effective duration of the test; If the cavity temperature is reached before the time expires, the test cycle will end successfully

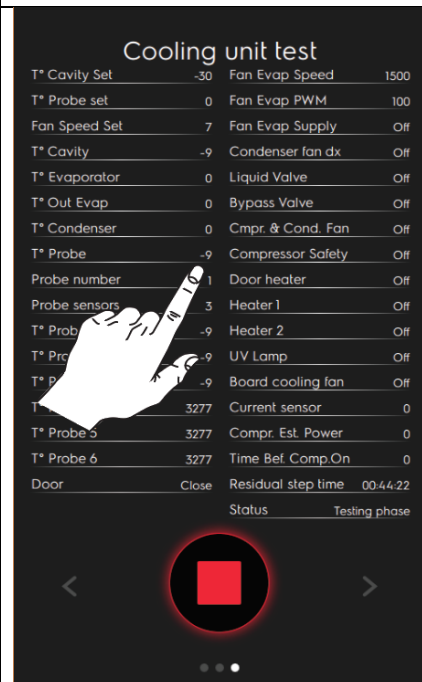



The screenshot below shows the correct phase concluded.

If the all configuration test are concluded with positive result, confirm with the button and the unit restart automatically.

In case some test is not performed, or interrupted, or you want to repeat it, you can go back to the previous page to repeat it

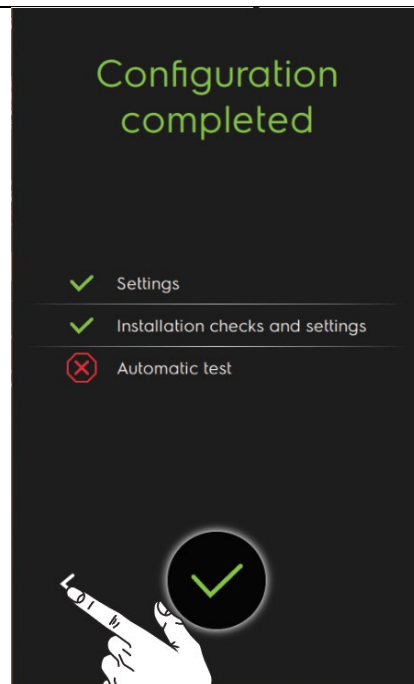
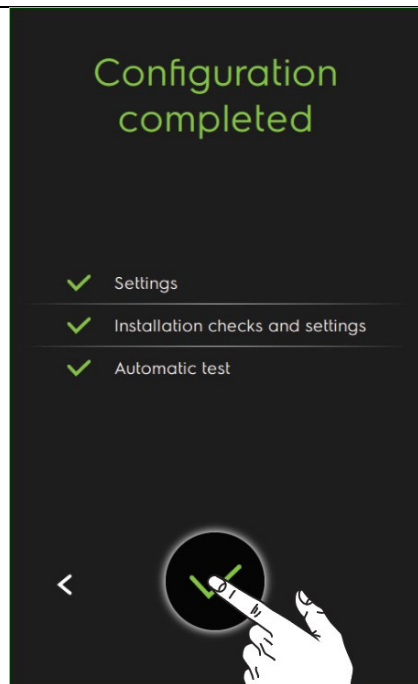
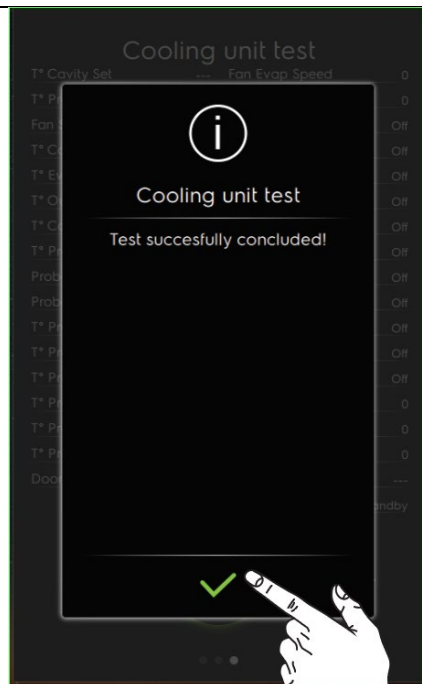

While if you want to continue without complete the WIZARD test in its entirety, the equipment will store in the alarm log, visible only in case of unloading with USB key, the actual performance data of the Wizard test, available in TXT format.

If you want proceed in this configuration "not performed" press the butto and the equipment will return to standard configuration menu for the normal use.

```

*** APPLIANCE INFO ***
PNC:9F727736 01
Serial number: 99999999
Appliance model: LW 50 Kg
Appliance type: BCF
UI App version:1.3.3
UI Resource version: 1.3.0
Brand: Electrolux
SETTE version: 3.3.4
RFS version: 201706192320
DTB version: NA
System version: 3.14.52-munich-1.3.5_prod
Boot version: NA
ACU FW version: 0.9.1
NIU FW version: 1.0.0

*** WIZARD REPORT ***
Start at: 06/02/2020 07:31
Settings: performed
Installation checks and settings: performed
Heating unit test: not performed
Cooling unit test: not performed
*** WIZARD REPORT END ***
    
```

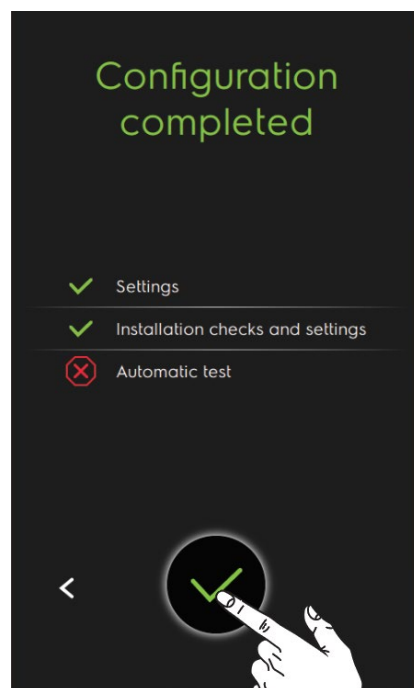



2.9.2 Manual Test Wizard

This is a procedure that the service can use in case automatic wizard is not enabled and where service technician can approach the unit using some cycle and environment to test all mechanical parts and refrigerant circuit to ensure that the unit function well.

2.9.2.1 Start manual wizard

1. Connect the unit to power supply, refer to paragraph 2.1.5 (electrical connection BCF)
2. Switch on the unit with the bottom refer to paragraph 2.3.2 (description main display)
3. Enter in the setting mode and set:
 - 1) language
 - 2) data
 - 3) time
 - 4) misurament unit
 - 5) sound
 - 6) Touchscreen Calibration
4. Access to service area refer to paragraph 2.3.3
5. Activate the “data monitor” The “data monitor” is visible after access to service area and present in the drawer main menu

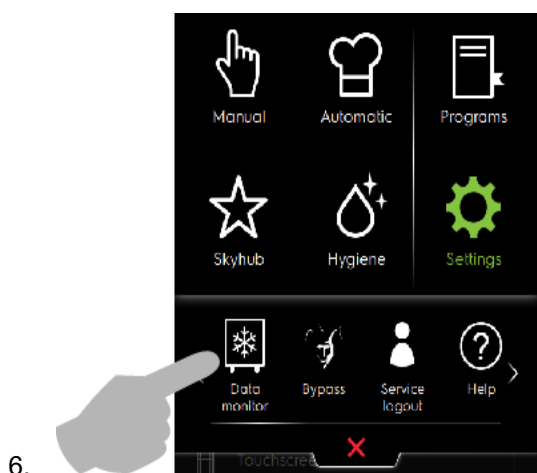

7.

Parameter Info			
T* Cavity Set	---	T* Out Evap	0
T* Probe set	---	Current sensor	0
Fan Speed Set	---	Fan Evap Speed	0
T* Cavity	20	Fan Evap PWM	0
T* Probe	20	Fan Evap Supply	---
Probe number	3	Fan Condenser 1	0
T* Probe 1	19	Fan Condenser 2	0
T* Probe 2	20	Liquid Valve	---
T* Probe 3	21	Compressor	---
T* Probe 4	0	Compressor Safety	0
T* Probe 5	0	UV Lamp	---
T* Probe 6	0	Compr. Est. Power	0
Door	Close	Time Bef. Comp.On	0
Door heater	---	Phase Elaps. Time	---
Heater 1	---	Phase Est. Time	---
Heater 2	---	Sequence Elaps. Time	---
T* Condenser	0	Sequence Est. Time	---
T* Evaporator	0	SETTE Status	None

8. Set the manual environment
9. Start the LITE HOT CYCLE setting:
Cavity temperature 30°C (86F)
Time to 25 minutes
Speed fan to 2 (it is already set)

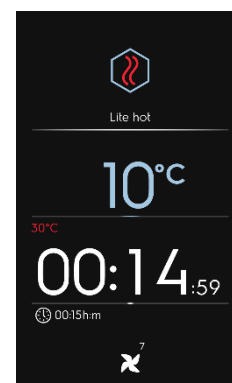
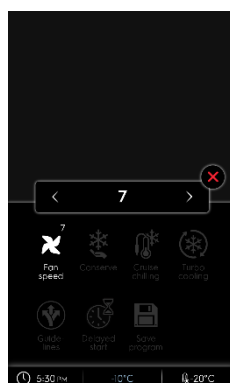

10. Check in the data monitor the value of temperature as



T° Cavity

T° Evaporator

Food probe

PWM =30



Warning: The values of these sensors must be more allied to the temperature present in the cavity

11. Check in data monitor the value of temperature as

T°condenser

T°out evaporator



Warning: The value of these sensors must be different from the other upper probe described (if there is some wrong value or the value does not result correct please check the correct position of connectors or replace the probe)

12. Check in the data monitor the “heater 1 and 2” are “active” (an automatic algorithmic start and stop the heaters alternatively.: the value is normally shown active or off .This alternative ON/OFF of is more clear if the temperature is near to set of cavity stop)

13. Check in the data monitor the Current sensor (this value is mAmp.) the result should be equal to components active as, heater x2 (depend on the unit) and the fan speed if it is active **I=P/V**.

14. At the End of LITE HOT CYCLE (no more than 25 minutes starting to 19°C (66.5F) of cavity) setting to start a X FREEZE cycle

15. X FREEZE CYCLE set:

Cavity temperature -30°C (-22F)

Time to 13 minutes

Speed fan to 7

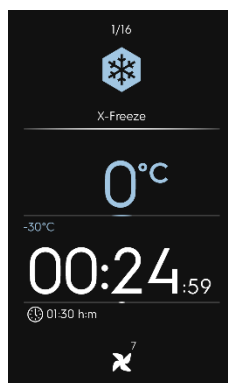
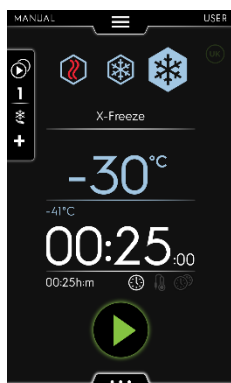

16. Check in the data monitor the value of temperature as (could be that the impuls start are active)

T° Cavity

T° Evaporator

Food probe

T° Condenser

T°Outevap.

Compressor “active”

Cavity fan “active” (on only temp CAVITY + out evap under 20° (68F))

Door heater

Current sensor (the value showed only by component to 220V)



Solenoid valve active (IN USA MODEL ONLY ONE OF TWO IS ACTIVE N1 IS WORK N2 IS ONLY IN START OVER -10°C (14F))

Door frame active

- The temperature set in this cycle will arrive to set before the countdown set in the time. In case it reaches before Stop the cycle and Start a manual defrost (door open is better) The Heaters are always ON

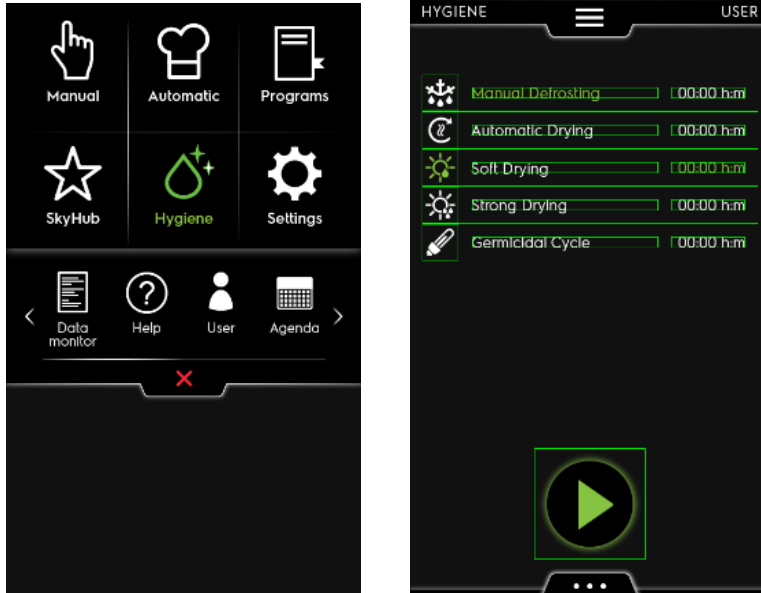

- The defrost lasts 30 minutes ,at the end of cycle remember to logout service
- Enter in the drawer main menu and logout the service or switch Off the unit

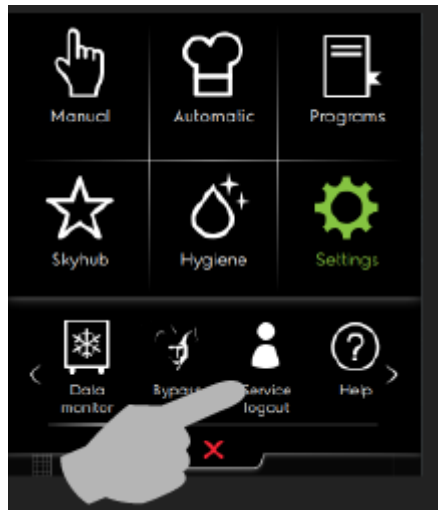



3. USE OF APPLIANCE

3.1 OPERATING INSTRUCTIONS

Please refer to the Installation and Operating Manual of the appliance; the document is available for authorized technicians on the web sites (PRIDE-SERVICE PORTAL- AGELUX etc..) In case of any doubt, refer to your local country customer care.

Code of user manual: 595R362..

3.2 PREVENTIVE MAINTENANCE PLAN (FOR SERVICE): OPERATION FREQUENCY

Please refer to the dedicated document available for authorized technicians on the web sites (PRIDE-SERVICE PORTAL- AGELUX etc..) In case of any doubt, refer to your local country customer care.



4. DETAILED APPLIANCE AND COMPONENTS DESCRIPTION/FUNCTIONING

4.1 MAIN BOARD “PETRA”

4.1.1 Functionality

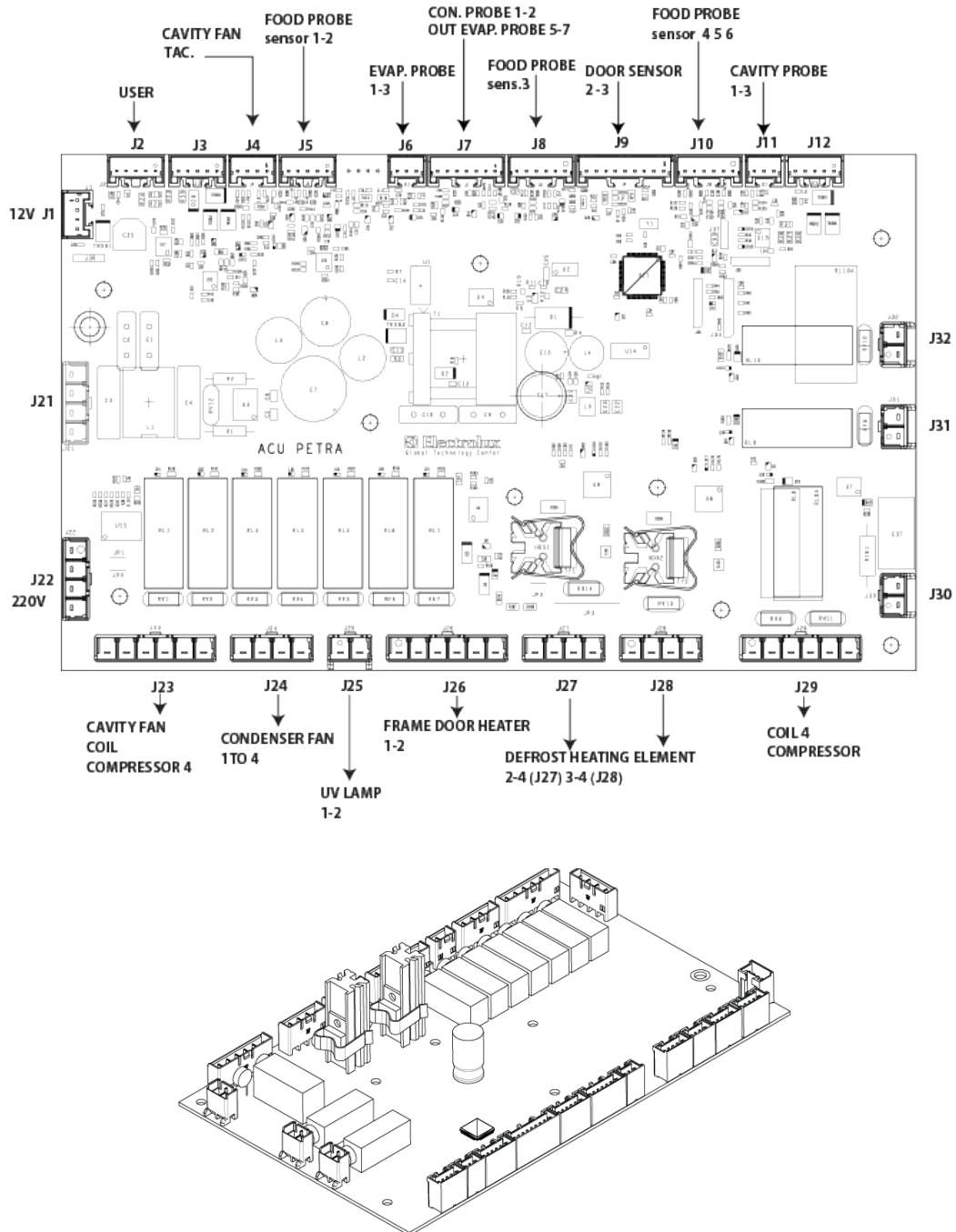



4.2 USER INTERFACE “TOUCH”

4.2.1 Functionality touch panel

The UI of the touchscreen appliances is supplied from the ACU(petra) connector j2 into contact J7.

If the user interface (user board) cannot communicate with any other board for more than a determined time (ex 15") any running cycle will be stopped. The error icon will show a message "ECom". No cycle can be launched till the communication is established again.

DISPLAY BOARD= connects to the U.I on J18 / J20 / J21

USER BOARD (U.I)= connects to the O/I board J1 to X21 / J7 connects to the ACU J2. (J15 is the usb cable)

O/I ON OFF BOARD (SM)= connects into the EWD and supplies the KSM (on of relay) when turned ON.

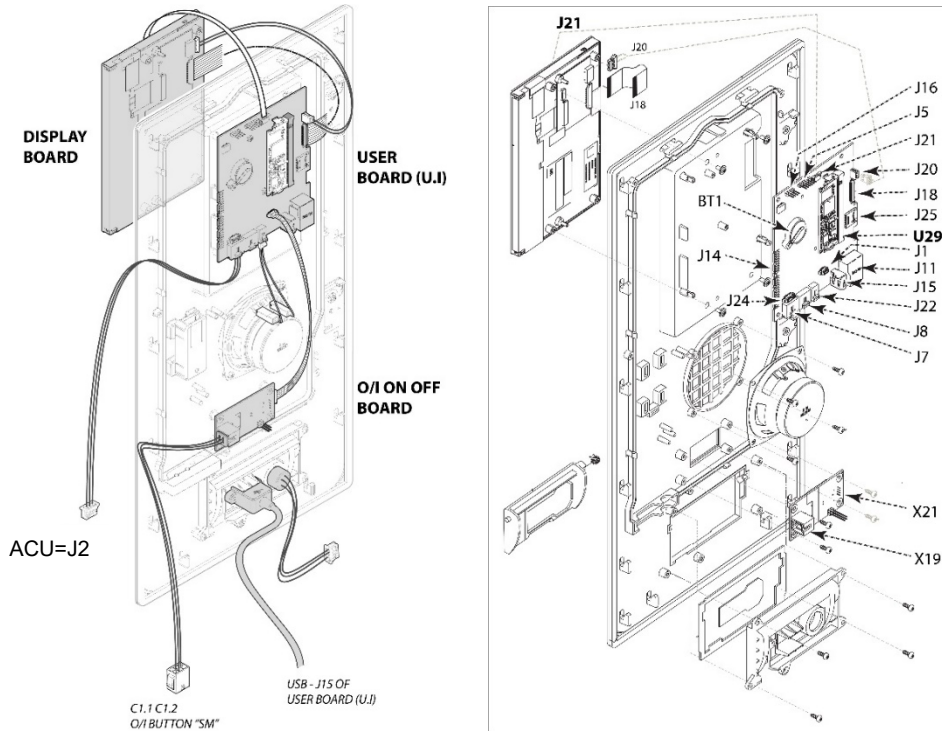

CONNECTOR	FUNCTION	NOTES
BT1	BATTERY CR2032	DATE / TIME MEMORY
J1	ON / OFF	12V AND 0/1 SWITCH STATE
J5	U9 CONTROL	NOT USED / EMPTY
J7	PMACS	J7 is CONNECTED TO ACU (POWER BOARD) INTO J2 CONNECTOR
J8	PMACS	
J11	ETHERNET	NOT USED / EMPTY
J14	NIU	FOR WIFI ANTENNA
J15	USB	USB PORT ON DISPLAY
J16	DEBUG	NOT USED / EMPTY
J18	LCD DISPLAY	FLAT CABLE
J20	LCD BACK LIGHT	CABLE
J21	DISPLAY BOARD	TOUCH SENSING RESISTIVE
J22	SPEAKER	CABLE
J24	ADDRESS	NOT USED / EMPTY
J25	MICRO SD	MEMORY CARD (LOGS/IMAGES)
U29	CORE BOARD	CPU
X21	COMUNICATION CABLE	12V AND 0/1 SWITCH STATE
X19		PHASE 230V IN, CONNECTED TO C1.1 & C1.2 of EWD "SM"
RECOVERY		CONNECTED TO ACU (POWER BOARD) J2

* **Note:** the J7/ PMACS can be connected to any J2(ACU petra) connection of the UI;J7 vs J8 are interchangeable.

X21 & X19 are the numberings of the ON/OFF board, but also the ACU has the same numberings!!



4.2.2 PMH power supply 100-240 Vac to 12V dc

General Information:

The power supply has input from 85Vac to 264Vac with nominal output voltage of 12V. The highly efficient convection cooling construction can operate from -30°C to 70°C

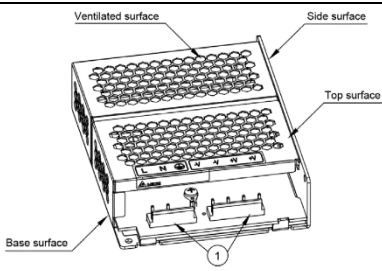
	INPUT Rating/ characteristics	
	Nominal Input Voltage	100 - 240 Vac
	Input Voltage range*	85-264 Vac
	Nominal Input Frequency	50-60 HZ
	Input Frequency Range	47- 63 HZ
	DC Input Voltage Range **	120- 375 Vdc
	Input Current	< 1.5A@ 115Vac, <0.80A@230V
	Effeciently at 100% Load	>83%@115Vac & 230V
	Max Power Dssipation	No load < 0.3W @ 115Vac, < 0.5W @ 230Vac
		100% Load < 11.0W @ 115Vac & 230Vac
Max In rush Current (cold start)	< 30A @ 115Vac, < 60A @ 230Vac	
Leakage Current	< 30A @ 115Vac, < 60A @ 230Vac	
	OUTPUT Rating/ characteristics	
	Nominal Input Voltage	12Vdc
	Factory Set point Tolerance	No potentiometer (11.64 to 12.36Vdc)
	Ouput Current	0-4.5A (54W max.)
	Output Power	54W
	Line Regulation	< 1.0% (@ 100-264Vac input, 100% load)
	Load Regulation	< 2.0% (@ 100-264Vac input, 0-100% load)
	PARD**** (20MHz)	< 120mVpp
	Rise Time	< 100ms @ nominal input (100% load)
	Start-up Time	< 2500ms @ 115Vac (100% load), < 1500ms @ 230Vac (100% load)
Hold-up Time	> 5ms @ 115Vac, > 25ms @ 230Vac (100% load)	
Dynamic Response (Overshoot & Undershoot O/P Voltage)	± 5% @ 100-264Vac input, 0-50%, 0-100%, 50-100% load (Slew Rate: 0.1A/μS, 50% duty cycle @ 5Hz to 1kHz)	
Start-up with Capacitive Loads	3,000μF Max	
PROTECTIONS		
Overvoltage	< 17.5V, SELV Output, Latch mode	
Overload / Overcurrent	115~150% of rated load current, Hiccup mode, Non-Latching (Auto recovery)	
Over Temperature	< 85°C Surrounding Air Temperature @ 100% load, Latch mode	
Short Circuit	Hiccup Mode, Non-Latching (Auto-recovery when the fault is removed)	
Internal Fuse at L pin	T 3.15AH	
Protection Against Shock	Class I with PE* connection	

1) Input & output terminal block connector

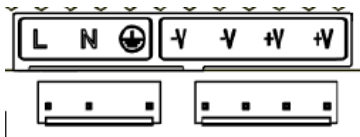



4.3 SEMI-ERMETIC COMPRESSOR

4.3.1 Over view

The compressor consists of a framework hosting the electric engine inside and the mechanical part of the compression piston.

The engine, which is suitably connected to the power supply, triggers the crank gear hence moving the pistons to the bottom of the cylinder and activating the suction.

When the piston moves in the opposite direction, the refrigerant gets compressed and flows through the delivery pipes.

4.3.2 Expected use of the unit

This compressor has been designed and manufactured only for the compression of the HFC-HFO (R404A, R507, R134a, R407C, R407F, R448A, R449A, R450A, R513A, R452A) and HCFC - CFC refrigerants (when national laws allow it only) within the operational fields as described by the attached application charts, with the restraint of a delivery temperature of 130°C and overheating at the suction between 5K and 30K.

The employed refrigerant has to have a humidity content of 10 ppm.

4.3.3 What follows is forbidden:

- The use outside the operational field and the above mentioned restrains;
- The compression of a fluid other than the above mentioned ones;
- To plunge totally or partially the compressor into fluids or to subject it to strong jets of water;
- The use into places at risk of explosion;
- The use at ambient temperatures lower than -20°C or higher than 60°C;
- The use into a completely closed place (not well aired);
- The use in places where corrosive chemical agents are present;
- The storage of combustible or flammable materials in the installation area of the compressor.

IMPORTANT: The plate of each compressor reports type and quantity of oil loaded at the factory.

For any possible topping up and/or replacement of the lube, use the type indicated on the plate only.

4.3.4 Compressor identification

Each compressor is identified thanks to a serial number reproduced on the riveted metal plate, in compliance with the EN 12693 regulation; this plate specifies:

- Manufacturer's name Compressor model Serial number Manufacture date
- Max delivery running pressure (PS, in bar)
- Max pressure of the low pressure area both in the running and in the idle condition (Psi, in bar)
- Number of phases of power supply
- Nominal voltage (V), frequency (Hz), current when the rotor is blocked (A)
- Max running current (A).
- IP protection category.
- Nominal rotation speed (RPM).
- Displaced volume (m³/h)

4.3.5 Airing of the installation room

For preventing dangerous concentrations of refrigerant in case of unforeseeable leaks, it is necessary to provide a suitable airing in the room where the compressor is located.

The installation room has to be equipped with natural airing or mechanical ventilation, in compliance with the applicable technical regulations

Since possible refrigerant leaks would tend to occupy the lowest part of the surrounding space, we recommend placing the suction of the air exchange system in a lower position.



4.3.6 Pipes Connections

Before starting the installation of the compressor, discharge the pressure of pre-charge by acting on both service valves.



Warning: Do not remove any component from the compressor before having executed this operation. Execute the installation in the following way:

1. **Remove the service valves of the compressor;**
2. **Weld the service valves to the system pipes;**
3. **Reassemble the service valves on the compressor;**
4. **Check the leaks from the pipes by means of a pressure test with N₂ or dry air following all the required safety procedures such as, for example, the use of a pressure reducer placed between the bottle and the system and leaving the compressor service valves closed**



Warning:
During this test, do not overcome the standstill pressure;

5. **Open the service valves of the compressor;**
6. **Take away the air of the system by means of the vacuum till a minimum of 1,5 mbar;**
7. **Fill up the system with refrigerant.**



Warning:
Do not use the compressor to create a vacuum
Do not power ON the compressor in vacuum conditions!



Warning:
Do not use the compressor to fill up the system with refrigerant.



Warning:
Before connecting, the service valves to the pipes be sure that all the plastic caps have been taken away. Avoid, as much as possible, the air inlet into the compressor!
Keep the connections closed during the welding of the service valves to the pipes.
Once the service valves have been reassembled, keep them closed until the vacuum procedure is not implemented.
Make sure that all pipes and joints are perfectly clean and leak-proof.



4.3.7 Table of pipe connection of Dorin compressor

The table shows the standard indications regarding pipe connections (*Dorin compressor*)

Range	Model	Oil charge	Suction	Discharge	Net weight	Range	Model	Oil charge	Suction	Discharge	Net weight	
		[kg]	SL [mm]	DL [mm]	[kg]			[kg]	SL [mm]	DL [mm]	[kg]	
H11	H51CS	1,0	12s	12s	35	H35	H401CS	2,0	22s	18s	89	
	H80CC	1,0	12s	12s	36		H451CC	2,0	22s	18s	91	
	H80CS	1,0	16s	12s	36		H451CS	2,0	28s	18s	89	
	H101CC	1,0	16s	12s	37		H551CC	2,0	28s	18s	91	
	H101CS	1,0	16s	12s	37		H551CS	2,0	28s	22s	91	
	H151CC	1,0	16s	12s	38		H701CC	2,0	28s	22s	91	
	H151CS	1,0	16s	12s	38		H701CS	2,0	28s	22s	91	
	H181CC	1,0	16s	12s	39		H751CC	2,0	28s	22s	91	
	H181CS	1,0	16s	12s	39		H751CS	2,0	35s	22s	91	
	H201CC	1,0	16s	12s	40		H1002CC	2,0	35s	22s	99	
	H201CS	1,0	18s	16s	40		H801CS	2,0	35s	22s	91	
	H221CC	1,0	18s	16s	41		H1003CC	2,0	35s	22s	99	
	H221CS	1,0	18s	16s	41		H41	H851CS	2,5	35s	28s	125
	H251CC	1,0	18s	16s	41			H1201CC	2,5	35s	28s	130
	H251CS	1,0	18s	16s	41			H1001CS	2,5	35s	28s	127
	H281CC	1,0	18s	16s	43			H1501CC	2,5	42s	28s	131
	H281SB	1,0	18s	16s	44			H1501CS	2,5	35s	28s	127
	H281CS	1,0	18s	16s	44			H2001CC	2,5	42s	28s	131
H51CS	1,0	12s	12s	35	H1601CS	2,5		42s	28s	134		
H80CC	1,0	12s	12s	36	H2201CC	2,5		42s	28s	136		
H80CS	1,0	16s	12s	36	H5	H2000CS	3,5	42s	28s	190		
H2	H290CS	1,4	22s	16s		54	H2500CC	3,5	54s	28s	185	
	H300CC	1,4	22s	16s		54	H2500CS	3,5	54s	28s	185	
	H300CS	1,4	28s	16s		54	H3000CC	3,5	54s	28s	199	
	H350CC	1,4	28s	16s		54	H2700CS	3,5	54s	35s	200	
	H350SB	1,4	28s	16s		54	H3200CC	3,5	54s	35s	205	
	H380CC	1,4	28s	16s		56	H2900CS	3,5	54s	35s	205	
	H380SB	1,4	28s	16s		56	H3400CC	3,5	54s	35s	205	
	H390CS	1,4	28s	16s		56	H6	H3000CS	3,5	54s	35s	235
	H392CS	1,4	28s	16s		56		H3500CC	3,5	54s	35s	246
	H32	H403CC	2,0	28s	16s	75		H3500CS	3,5	54s	35s	233
H403CS		2,0	28s	16s	76	H4000CC		3,5	54s	35s	249	
H503CC		2,0	28s	16s	79	H4000CS		3,5	54s	42s	244	
H503CS		2,0	35s	16s	80	H4500CC		3,5	54s	42s	252	
H743CC		2,0	35s	16s	81	H4500CS		3,5	54s	42s	253	
H33	H355CS	1,8	22s	16s	77	H5000CC		3,5	54s	42s	253	
	H405CC	1,8	22s	16s	77	H7	H5000CS	8,5	66s	42s	350	
	H405CS	1,8	28s	16s	78		H5500CC	8,5	66s	42s	355	
	H505CC	1,8	28s	16s	78		H5500CS	8,5	80s	42s	350	
	H505CS	1,8	28s	18s	78		H6000CC	8,5	80s	42s	355	
	H705CC	1,8	28s	18s	78		H6000CS	8,5	80s	42s	355	
	H705CS	1,8	28s	18s	78		H7500CC	8,5	80s	42s	357	
	H755CC	1,8	28s	18s	78		H7501CS	8,5	80s	54s	355	
					H8001CC		8,5	80s	54s	357		
					H8000CS		8,5	80s	54s	360		
					H9000CC		8,5	80s	54s	366		

4.3.8 Electrical connections

The connection to the power supply has to be made by opening the box of the electric connections and by connecting the phases of power supply, the equipotential wire and the wires for the signals of the temperature sensors following the instructions provided inside the lid of the box and on the compressor plate.

Connect the carter resistance, whenever it is provided, and the other electric equipment's.

The plate positioned on each compressor shows the motor's voltage and frequency values: make sure they comply with the line's voltage and frequency.

	STANDARD	380-420 50HZ / 440-480 60 HZ	Y
		220-240 50 HZ / 265-290 60 HZ	Δ
	USA	208V 60HZ	Δ



Warning:

For the dimensions of the contactors, cables and protection devices (fuses, circuit breakers) of the electrical power refer to the values of maximum working (FLA) and start-up current (LRA) shown on the unit data plate

4.3.9 Protection System

The motors are equipped with PTC internal protection or through THERMIK; as for PTC sensors, the relevant connections (indicated as T1- T2 in the wiring diagram) shall not be connected to the power supply voltage but fed only through the motor protection electronic module (REL), available for protections such as thermistor; vice versa for protections such as thermic the use of (REL) is not necessary and the contacts shall be connected in series with the other system protections.

4.3.10 Commissioning: Preliminary Works

Feed the carter resistance, if provided (start the refrigerant recharge process not below $35^{\circ}\text{C} \pm 40^{\circ}\text{C}$ of the oil temperature). Once the indicated temperatures are reached, start the compressor.



Warning:

Before starting the compressor:

1. **Make sure the suction service valve and the discharge gas valve are open;**
2. **Do not start the compressor when high vacuum conditions occur inside it. Non-observance of this warning can have very serious consequences such as the sudden increase of the internal pressure with possibility of explosion and consequent risks for the staff operating, passing by or staying close to the machine.**

Check the oil level and verify that the oil level is between the levels clearly indicated on the oil sight glass, as shown in the following figure:



OIL LEVEL INDICATION

During the first hours of operation of the compressor, check the oil level several times.



Warning:

If oil have to be added, use the type indicated on the nameplate and do it gradually, checking his return to compressor: **Danger of liquid slugging!**



Warning:

During compressor, functioning, liquid migration from evaporator to compressor has to be avoid.

The functioning with liquid refrigerant may cause following failures:

3. **Oil with less lubricant power;**
 4. **Broken of valves and consequent damage of other components**
- The installer** shall verify that the plant has all the solution to avoid the liquid migration from evaporator to compressor, in all possible operating conditions. This phenomenon may be identified by the following functioning failures:
5. **Ice or frost formation on the suction service valves and on suction line;**
 6. **Excessive foam formation on lubricant, visible through warning light;**
 7. **Low temperature of surface of oil sump**
 8. **Take a sample of oil and verify its good quality (color and acidity).**
 9. **Every time the oil is replaced, also the oil filter shall be verified.**



Warning:

10. POE and PAG oils are strongly hygroscopic. Moisture binds itself chemically to the oil molecule. Carefully operate while replacing the oil. Prevent the air from entering the circuit.

In case of refrigerant gas leak, aerate the room where the leak occurred before any operations. Do not stay in the machinery room if it has not been properly aerated; even if the gas inhaled is not harmful, the gas replaces oxygen and can therefore cause choking symptoms

4.3.11 Compressors Replacement

A particular attention shall be paid in case a compressor is replaced with another one; as a matter of fact in the circuit, a certain oil quantity could have been left such as to cause "liquid slugging" at the start. It could be necessary to remove a certain lube quantity from the new compressor. After the compressor starting check that the oil level is stabilized between the levels indicated in previous paragraph (4.1.1.9)

4.3.12 Compressor Disassembly

Make reference site to Dorin, for spare part catalog and instruction to disassemble.



Warning:

During operation of the machine periodically, check that the oil level is between the levels clearly marked on the sight glass. It could be useful to provide with regular oil analysis in order to check the lack of humidity and/or acidity.

4.3.13 Number of starts

Do not start the compressor more than 8 times per hour.

Let the machine run for at least 4 minutes for each starting.

However, be sure that numerous starting do not undermine the right oil level into the case



4.3.14 Rotalock Valves

UJ VALVES	
1	Process and manometer
2	Connection to compressor or receiver
3	Main connection
4	Pressostat port
	<p>SPINDLE BACK POSITION Process port closed</p> <p>SPINDLE MIDDLE POSITION All open</p> <p>SPINDLE FRONT POSITION Main connection closed</p>
	<p>SPINDLE BACK POSITION All open Process port closed by schrader</p> <p>SPINDLE MIDDLE POSITION All open Process port closed by schrader</p> <p>SPINDLE FRONT POSITION Main connection closed Process port closed by schrader</p>



4.3.15 Crankcase heater installations

It is recommended to fit an oil heater in the compressor crankcase, because, if the compressor is stopped, there is the possible storage of refrigerant inside the crankcase. The heater reduce the dilution of liquid refrigerant with the oil. On the oil level side, the compressor crankcase is already equipped with a hole where the resistance may be applied: **See the instruction below**

	<p>Insert the high temperature paste in the indicated hole (3g)</p>
	<p>Insert the crankcase heater in the housing moving it back and forth and turning several times</p>
	<p>Block the heater screwing the bushing supplied (When applicable). Tightening torque of the bushing 10 Nm</p>
	<p>The use of the bushing ensures an insulation class IP67 for the crankcase heater</p>

The standard resistances are:

100 or 200 W based on compressor size;

Voltage 230 V.

Warning:

Before energizing the crankcase heater make sure, the voltage is correct and that the heater is inserted and locked inside its seat by screwing the bush supplied

On demand the crankcase heater can be provided for different voltages or power



4.3.16 Electrical Connection Of The Compressor On The Unit

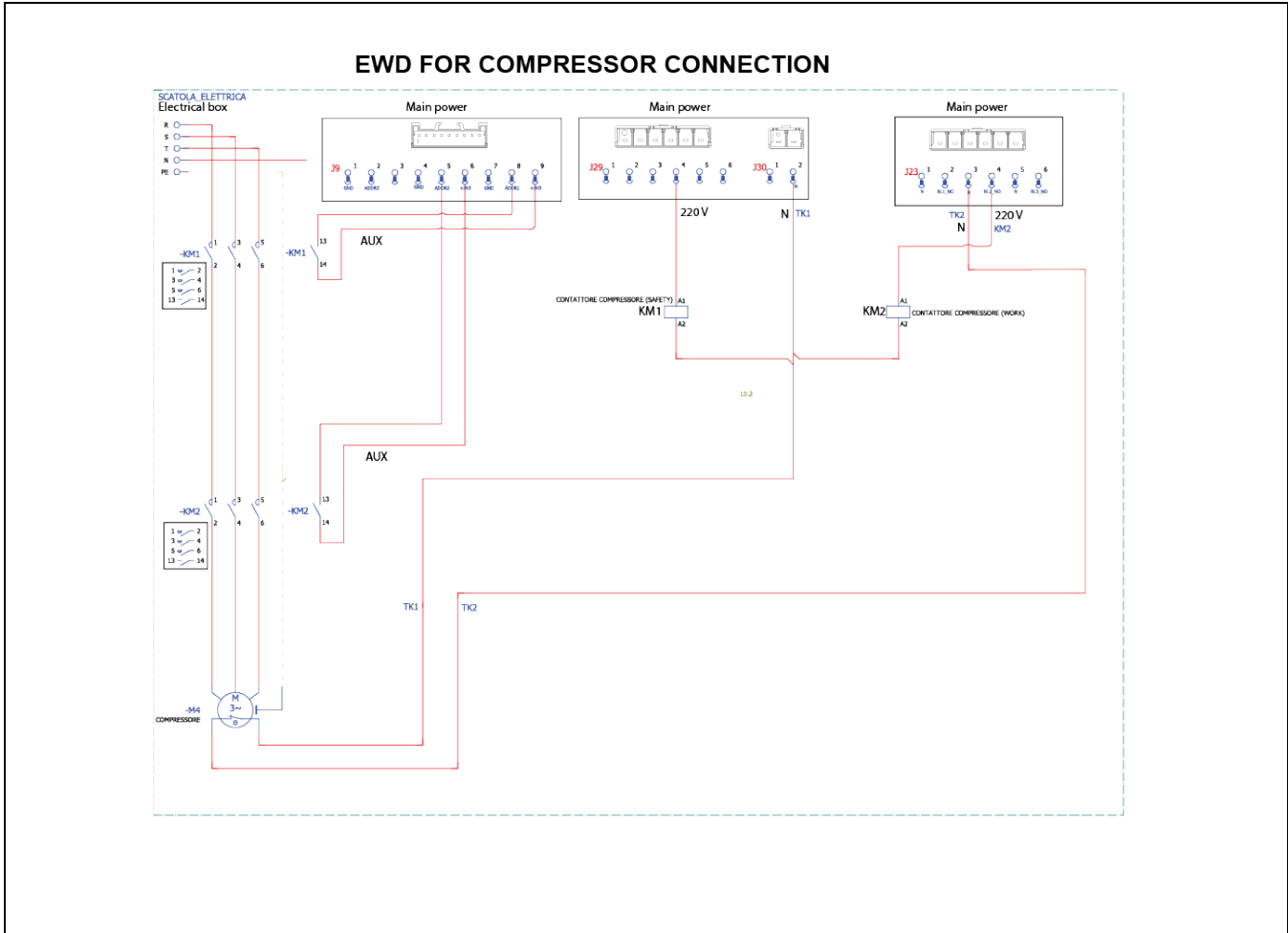



4.3.17 Evaporator Fan

4.3.17.1 Functionality fan

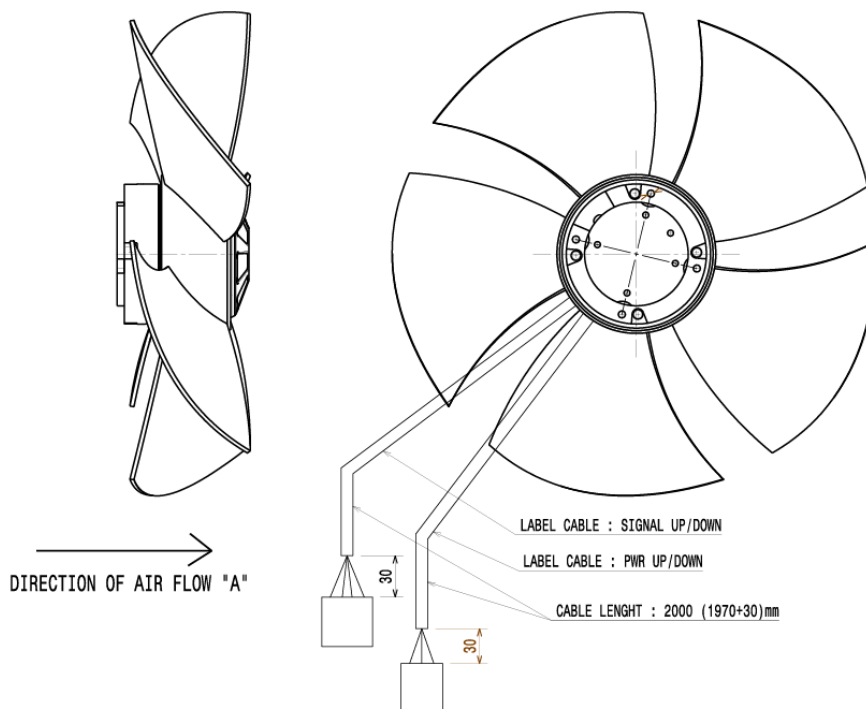

Cable COLOR	Position/label wire	Label cable	Voltage	200-240V
Black	Con10/L	PWR UP/DOWN	HZ	50-60
Blue	Con 11/L		Speed	1475/1500
Yellow/Green	Con 12/PE		P Couns.	165W
Blue	GND	SIGNAL UP/DOWN	A	1.35
Yellow	0-10Vdc/pwm		Protections	PTC
Red	+10VVdc		IP	54
White	TACH.			
Max speed	Yellow + Red			

Fan speed from UI	PWM signal [%]	[rpm]
FSP1	15	221
FSP2	30	443
FSP3	45	664
FSP4	60	885
FSP5	75	1106
FSP6	90	1328
FSP7	100	1475

Note: The evaporator fan is stop if the cavity probe and evap.out probe are both over 20°C.

Check in data monitor this temperature if they are over or under the value to (20°C) .to determine if fan run or they are stoped! (<20 stop 20>run)

Attention only PWM change (0 is stop > run) the power will be always active!



4.3.17.2 Electrical Connections Fan

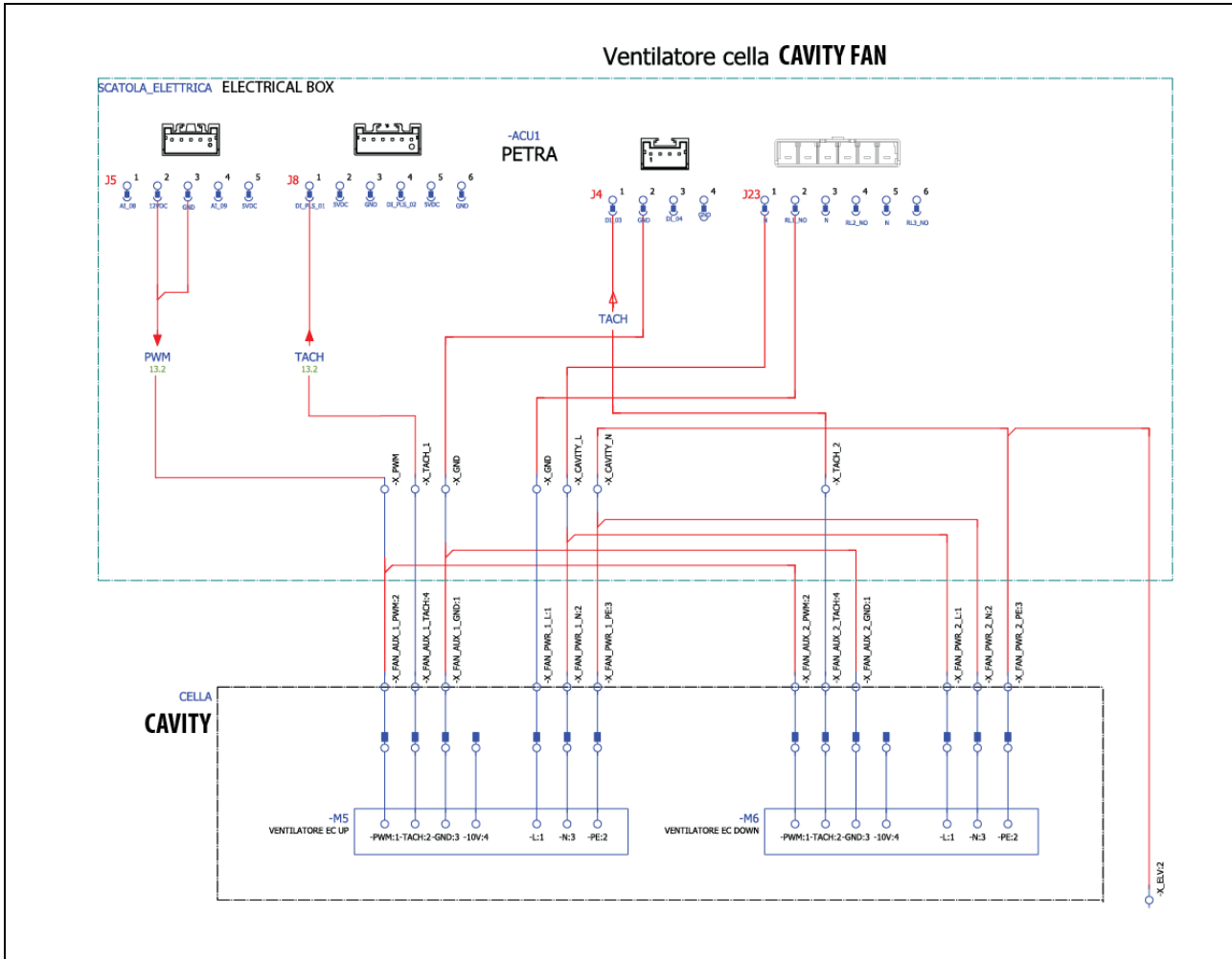



4.3.18 Probe's

4.3.18.1 Probe's feature

INTERNAL VIEW OF PIPE

Conversion table NTC 10K BETA 3435

TEMPERATURA	KOHM (nom)
-40	188,5
-30	111,3
-20	67,8
-10	42,45
0	27,28
10	17,96
20	12,9
25	10
30	8,313

Every cable has printed the name of component (cell/evap/outevap)

4.3.18.2 Electrical Connections Probes

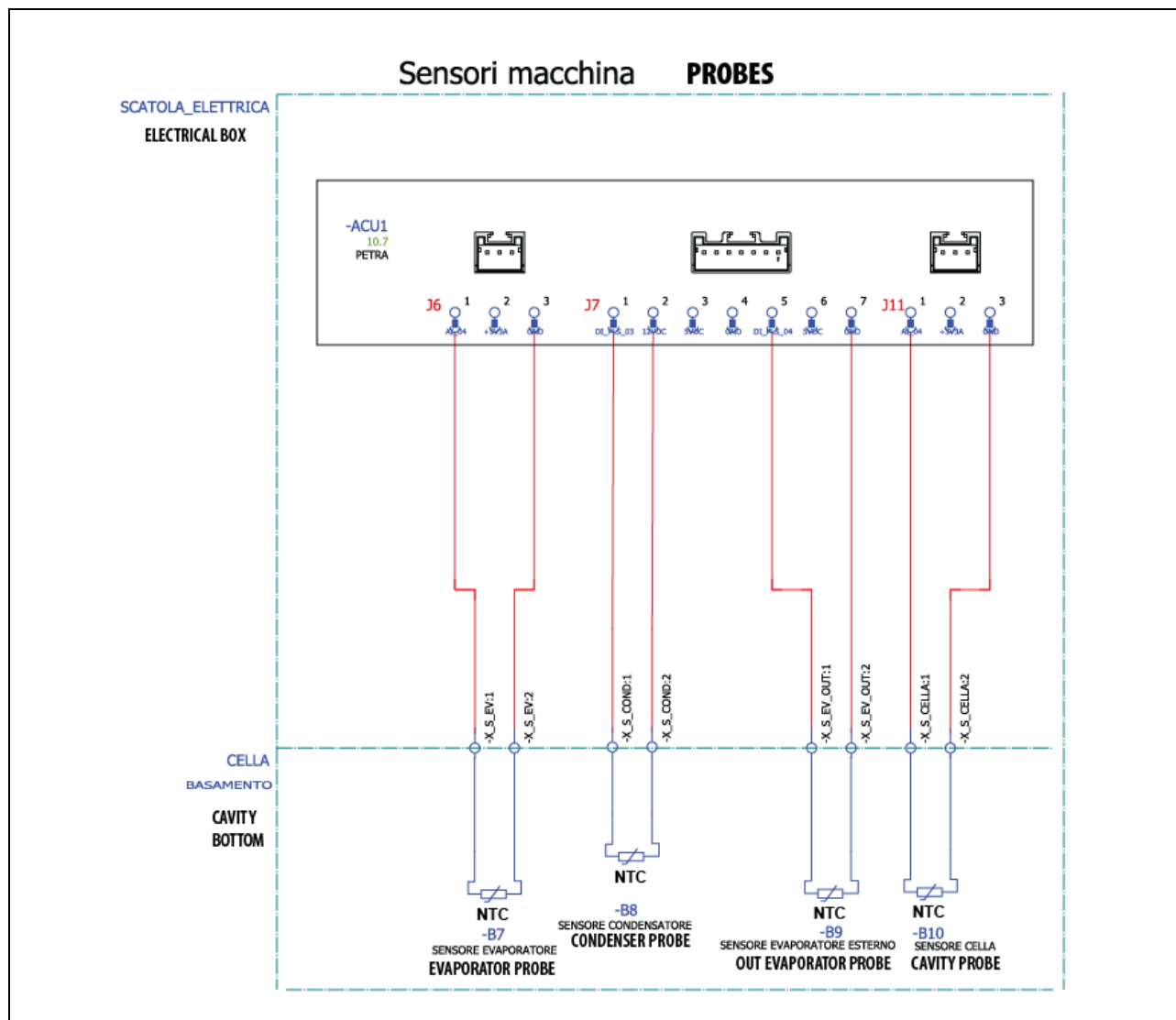



4.3.18.3 Probe functions

Descriptions	Colours	Where are positioned	Functionality
Cavity probe	Blue	Inside of the cavity on upper fan	Control logic the cavity temperature
Evaporator probe	Grey	Inside of evaporator	Control logic the defrost limit temperature
Out evaporator	Green	Out side, together sensor to thermostatic valve	Control logic the start stop cavity fan (+20 it is stopped together the logic control of the evaporator probe) + Usa model control the by pass of the solenoid valve (-10°C elv2) up to this temperature it is remain closed
Condenser probe	Black	Cooling unit in the outpipe of condenser	Control logic high temperature of the condenser

4.3.19 Food Probe

4.3.19.1 Functionality

CLIMATIC CATEGORY: (IEC 60068-1)
LOWER category temperature =C° -50
UPPER category temperature =C° 125

Application

- Heating and air conditioning systems
- Industrial electronics
- Automotive electronics

Features

- Fast response
- High measurement accuracy
- Epoxy resin encapsulation
- Ag-plated nickel leads (diam. 0.3mm)
- Kink for lead spacing 2.5mm
- WL: wire length

4.3.19.1.1 NTC Resistance Temperature Curve

Temperatur [°C]	R _{Nom} [Ω]	R _{Min} [Ω]	R _{Max} [Ω]	ΔR [±%]
-50	337293	320596	353990	5,0
-45	253325	241646	265005	4,6
-40	191908	183684	200132	4,3
-35	146593	140768	152418	4,0
-30	112877	108729	117025	3,7
-25	87588	84620	90556	3,4
-20	68471	66339	70602	3,1
-15	53910	52375	55446	2,8
-10	42739	41631	43848	2,6
-5	34109	33308	34910	2,3
0	27396	26817	27974	2,1
5	22140	21722	22557	1,9
10	17999	17699	18298	1,7
15	14716	14502	14930	1,5
20	12099	11948	12250	1,2
25	10000	9900	10100	1,0
30	8308	8205	8411	1,2
35	6936	6837	7035	1,4
40	5819	5725	5912	1,6
45	4904	4816	4991	1,8
50	4151	4070	4232	1,9
55	3529	3454	3603	2,1
60	3012	2944	3081	2,3
65	2582	2519	2644	2,4
70	2221	2164	2278	2,6

Temperatur [°C]	R _{Nom} [Ω]	R _{Min} [Ω]	R _{Max} [Ω]	ΔR [±%]
75	1918	1866	1970	2,7
80	1663	1615	1710	2,9
85	1446	1403	1489	3,0
90	1262	1222	1301	3,1
95	1105	1069	1141	3,3
100	970,2	937,4	1003	3,4
105	854,6	824,7	884,6	3,5
110	755,1	727,7	782,4	3,6
115	669,0	644,0	694,0	3,7
120	594,4	571,5	617,3	3,9
125	529,5	508,5	550,5	4,0



4.3.19.1.2 Kit 3 Food Probe With One Sensor

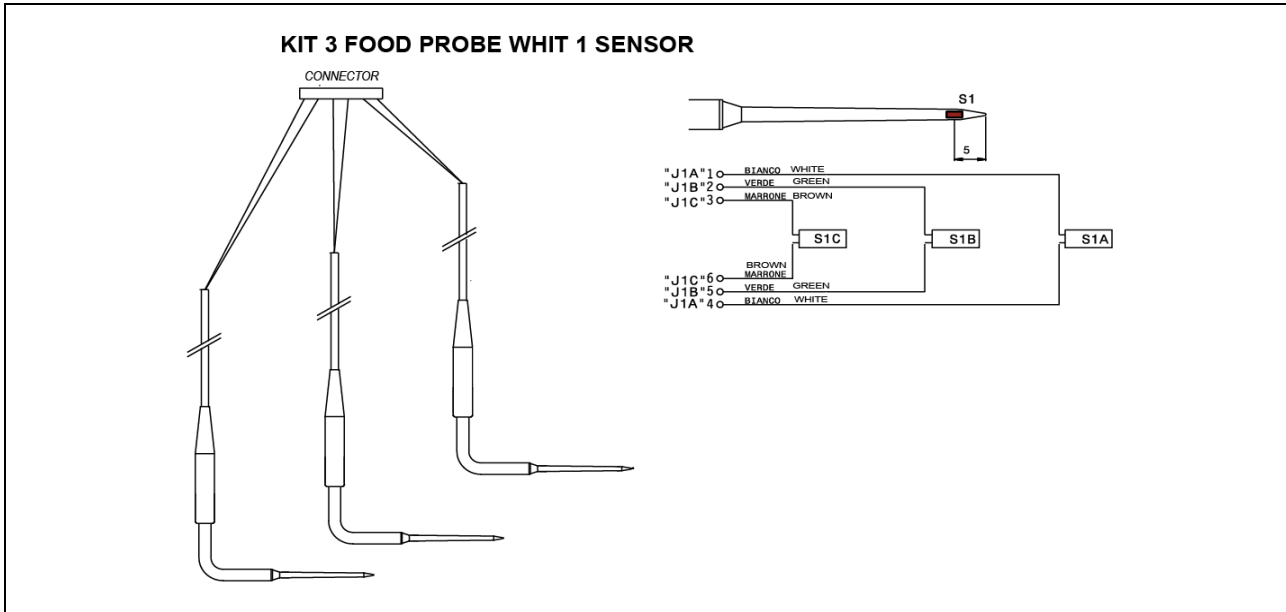

4.3.19.1.3 Kit One Food Probe With 3 Sensors

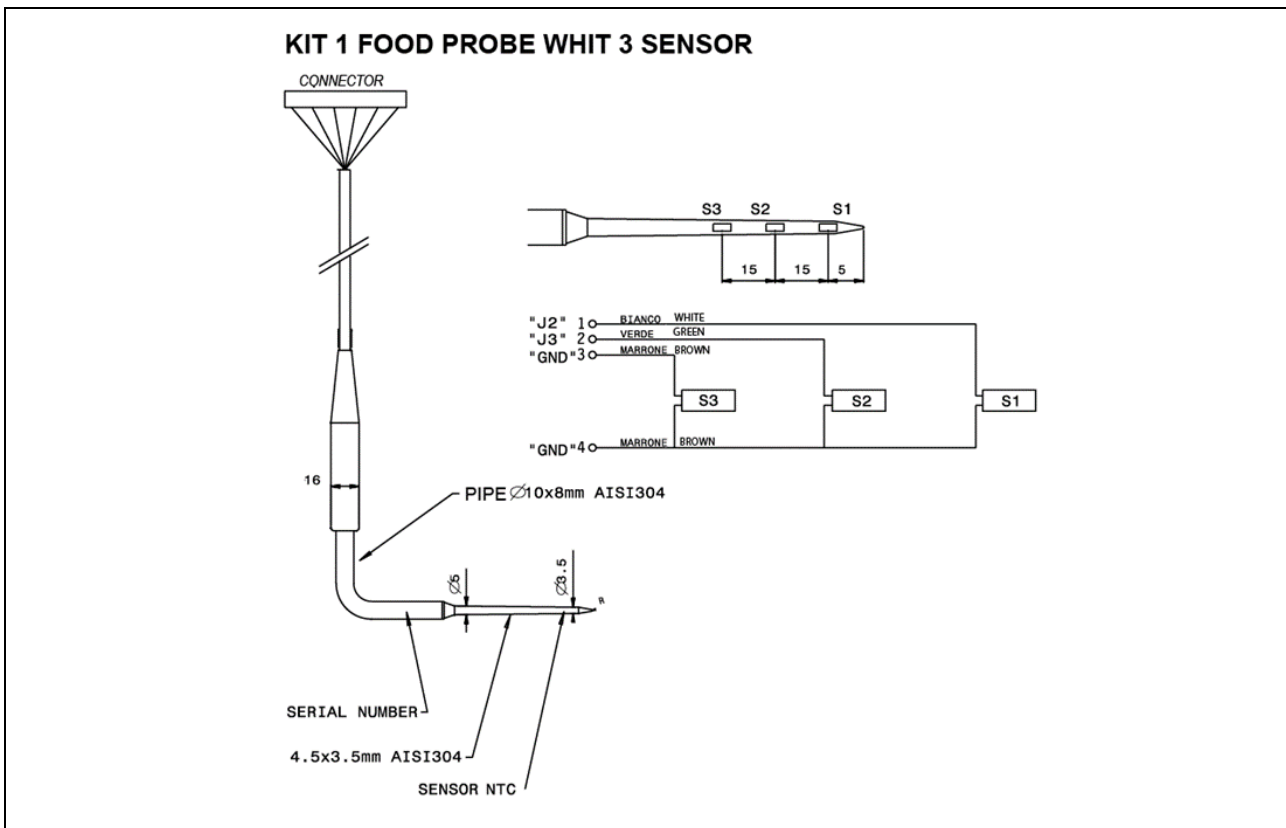



4.3.19.1.4 Kit One Probe With Six Sensor

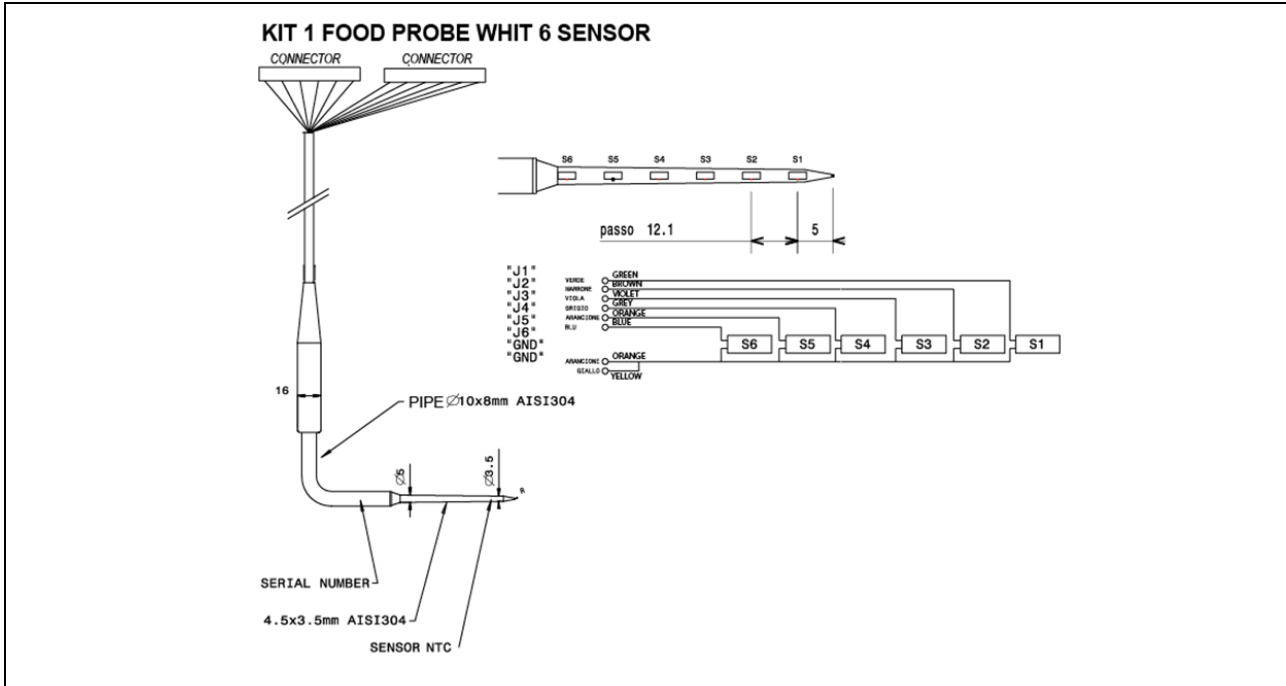



4.3.19.2 Electrical Connections Food Probes

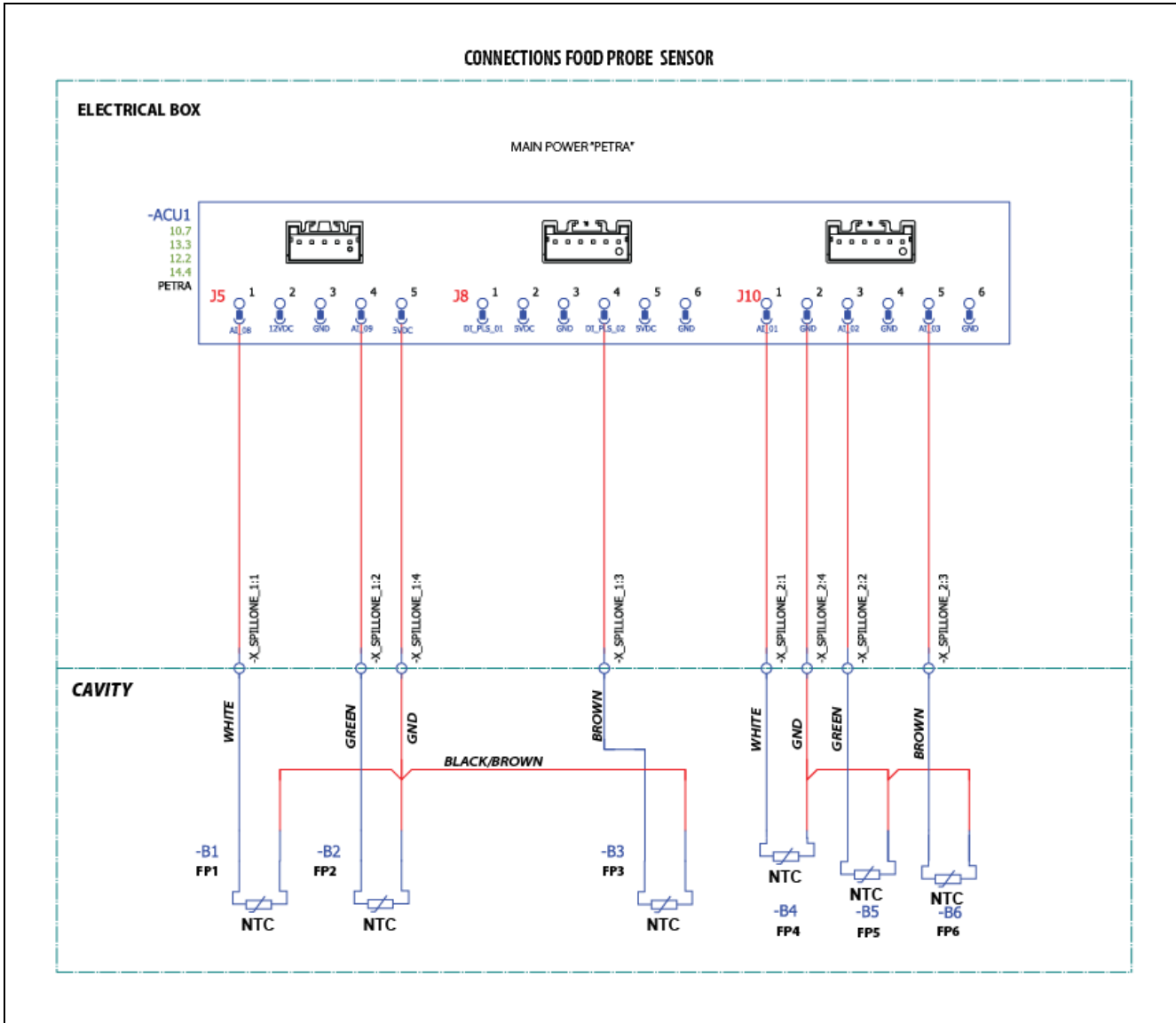

Wiring cable present on connector:



Color Yellow sensor n°1
 Color White sensor n°2
 Color Brown sensor n°3
 Color green and black GND
 Two connectors for 6 sensors



4.3.20 Heater Evaporator

4.3.20.1 Functionality

Located in the evaporator they work following different cycle:

Higine (defrost etc)

Hot lite cycle

Tension V	Nominal power W	Amp	Quantity
230	800 +5% - 10%	3.47	6gn=1/10gn=2
208 uL usa model	800 +5% - 10%	3.84	

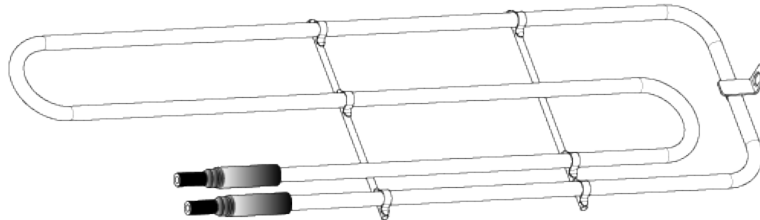

4.3.20.2 Electrical Connections Evaporator Heater

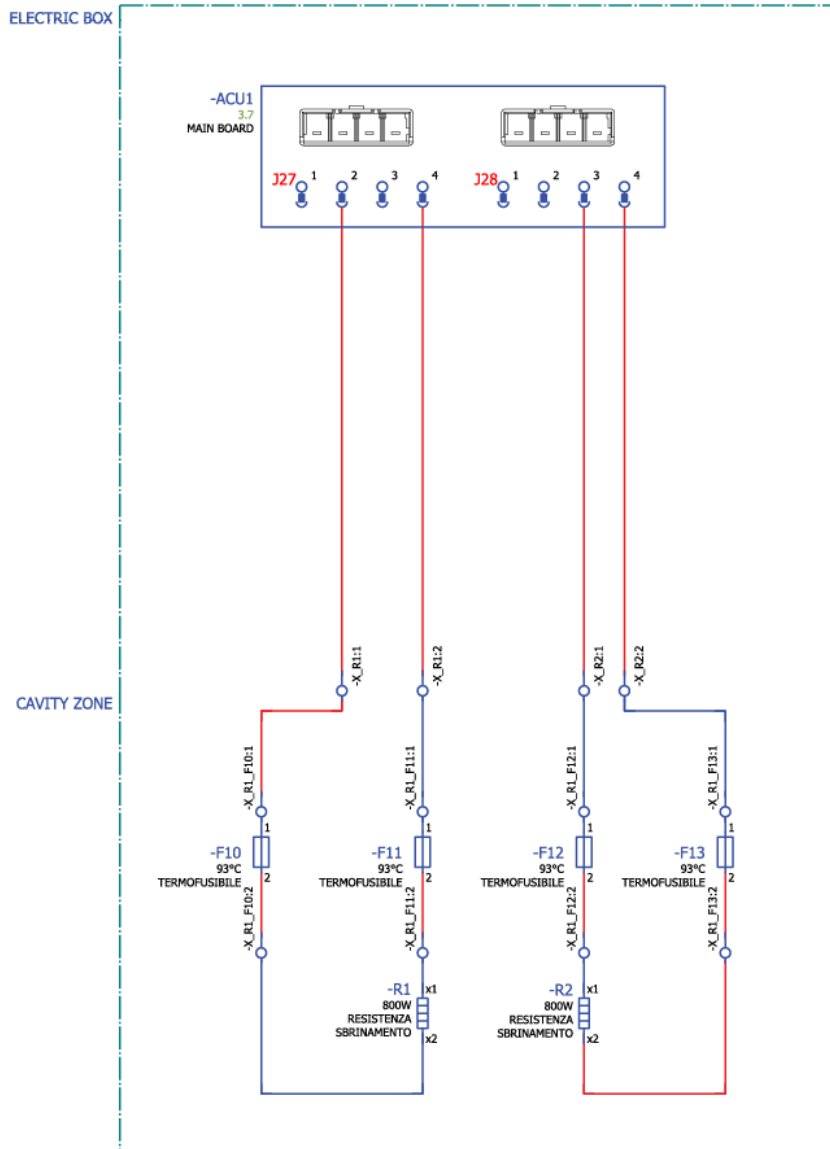



4.3.21 Test Digital I/O: Step By Step Digital Operable Components Testing

for automatic test digital refer to paragraph 2.10.3.6

4.3.22 Identify rapid“test cycles and components”

- Access to service area refer to paragraph 2.3.3
- Activate the “data monitor” The “data monitor” is visible after access to service area and present in the drawer main menu.

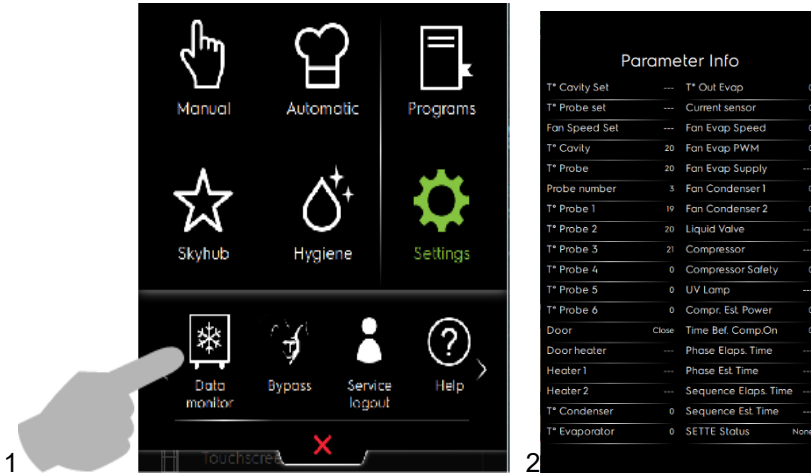

- Setting a cold cycle by pressing “Manual “ X_Freeze, Start
- Back to data monitor checking the value of probes (the value change follow the temperature) and the components active , as
 1. Compressor =Active
 2. Fan Condenser = Active
 3. Door= close
 4. Door heater = Active



- Stop cycle, keeping press the button

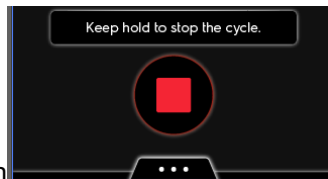

- Setting a Hot cycle by pressing “Manual “ Lite hot, Start

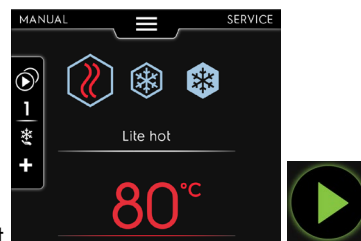



- Back to data monitor checking the value of probes and the components active , as
 1. Heater 1= active
 2. Heater 2= active
 3. T° Evaporator
 4. T° Cavity
 5. T° Probe

Also in this case the values of probes change following the temperature.

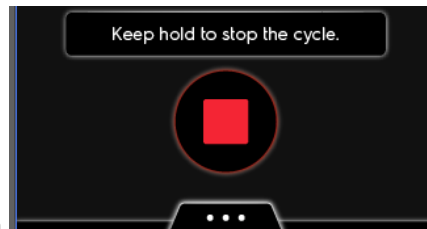

- Stop cycle keep hold the button

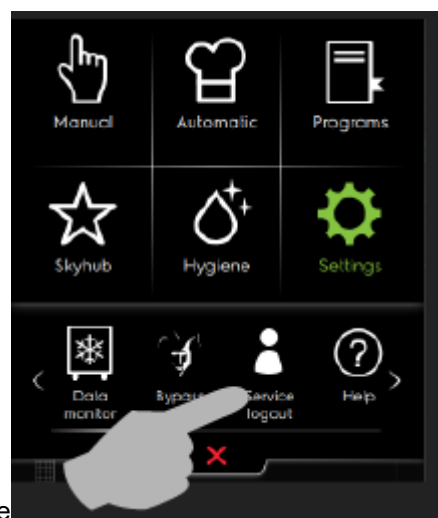







- Enter in the drawer main and logout the service



5. TROUBLESHOOTING

5.1 TECHNICIAN TROUBLESHOOTING

Anomaly	Type of anomaly	Description	Possible causes	Instructions to User	Service Action (phase# refers to Service Manual)
 swcTTm	INFO	Give information about switching operations from probe to time	Food probe not inserted in food	In case of cycles based on food temperature, insert the probe into the food otherwise the cycle will automatically switch to time	N.A.
 ECoM	ALARM Blocking Machine	Communication error between boards	-Internal error -Electronic boards disconnected -Electronic board failure	Try to switch the unit OFF/On. If the problem persists, call service	-Check electronic boards connections -Replace PCB -Replace inverter (where present)
 PFAC	ALARM Blocking Machine	Memorized parameters corrupted.	SW corruption	Try to switch the unit OFF/On. If the problem persists, call service	Upload SW using USB Key If the problem persists, replace UI
 PdEF	ALARM Resetting Machine	Memorized default parameters corrupted	SW corruption	The machine loses personalization. Operations can continue. If the problem shows up again, call service	Re-upload default settings Upload SW using USB Key
 EFnt	ALARM Blocking Machine on 30kg Reducing Performance on other models	Top evaporator fan failure	-parameter wrong setting -fan connector wrongly plugged - fan failure	Call service. - 30kg model (1 evaporator fan): unit stops and cannot operate until fixing the problem -Other models (more than 1 evaporator fan): unit continues working with reduced performance (Cycle ongoing: the cycle proceeds until end if there is at least one fan working. The cycle stops if no fan is working). During STANDBY: the alarm cannot be triggered	-Check parameters Eft and Efn fitting with the machine model; if not, reset parameters default. If problem persists, re-upload parameter settings with USB Key. -If the alarm shows up again, check fan connector(s) correct plugging and fix. -If the problem persists, replace fan.
 EFnb	ALARM Reducing performance until another fan is working	Bottom evaporator fan failure.	-parameter wrong setting -fan connector wrongly plugged - fan failure	Call service. - unit continues working with reduced performance until at least another fan is working (Cycle ongoing: the cycle proceeds until end if there is at least one fan working. The cycle stops if no fan is working). During STANDBY: the alarm cannot be triggered	-Check parameters Eft and Efn fitting with the machine model; if not, reset parameters default. If problem persists, re-upload parameter settings with USB Key. -If the alarm shows up again, check fan connector(s) correct plugging and fix. -If the problem persists, replace fan.
 EFnc	ALARM Reducing performance until another fan is working	Center evaporator fan failure	-parameter wrong setting -fan connector wrongly plugged - fan failure	Call service. - unit continues working with reduced performance until at least another fan is working (Cycle ongoing: the cycle proceeds until end if there is at least one fan working. The cycle stops if no fan is working). During STANDBY: the alarm cannot be triggered	-Check parameters Eft and Efn fitting with the machine model; if not, reset parameters default. If problem persists, re-upload parameter settings with USB Key. -If the alarm shows up again, check fan connector(s) correct plugging and fix. -If the problem persists, replace fan.









Anomaly	Type of anomaly	Description	Possible causes	Instructions to User	Service Action (phase# refers to Service Manual)
 E1	WARNING	Cavity low temperature (only during holding cycles: positive or negative.)	-Delay time set too short -Delta temperature set too narrow -Evaporator icing	The cavity temperature is below the holding cycle temp set point for more than the set time (default time = 1hour). The cycle will continue until stopping it. Open the door for increasing the temperature inside the cavity and check it after a couple of minutes. Launch a manual defrost cycle. Call service if the problem re-occurs.	-Enter in the service area check the set of parameter and check Delay Time and Delta Temperature settings -Check KOHM cavity temperature sensor: replace if needed Check KOHM out evaporator temperature sensor: replace if needed -Check rotation direction of the evaporator fans (three phases versions): fix if needed -Check the thermostatic valve setting: fix if needed (especially in remote models)
 E3	ALARM Blocking Machine	Cavity probe failure	-Connector unplugged -Probe and/or probe wire damaged	The chiller will continue working until the end of the running cycle Not possible start other cycle till to Technical Service replace the probe Call service	-Check KOHM temperature sensor: replace if needed -Check probe connection: fix (replace if needed)
 E4	ALARM No-blocking machine	Evaporator probe failure	-Connector unplugged -Probe and/or probe wire damaged	The chiller will continue working: the defrost setting will be based on time Call service and inform about the message displayed	-Check KOHM temperature sensor: replace if needed -Check probe connection: fix (replace if needed)
 E14	ALARM No-blocking machine	Out Evaporator probe failure	-Connector unplugged -Probe and/or probe wire damaged	The chiller will continue working Call service and inform about the message displayed.	-Check KOHM temperature sensor: replace if needed -Check probe connection: fix (replace if needed)
 E15	ALARM Blocking Machine	Condenser probe failure	-Connector unplugged -Probe and/or probe wire damaged	This failure blocks also running cycle Quickly remove the load from the cavity for preventing waste of food Call Service.	-Check KOHM temperature sensor: replace if needed -Check probe connection: fix (replace if needed)
 E16	ALARM Blocking Machine	Condenser high temperature	-Position of condenser probe is not correct -Fan condenser not working -The condenser is dirt or tapped -The unit does not discharge warm air due to position too near to wall	This failure blocks also running cycle Quickly remove the load from the cavity for preventing waste of food. Using a vacuum cleaner, remove any dust/dirt from the condenser inlet-air grid. If the alarm persists call service.	-Check the installation of the unit respect the installation instruction: correct if needed -Clean condenser -Check if fan condenser run (check connectors; replace fan if needed) -Check Condenser High Temp value of the parameter list: correct if needed -Check KOHM temperature sensor: replace if needed -Check probe connection: fix (replace if needed)
 Eprb1	ALARM Blocking food probe cycles	Core probe failure sensor n°1	-Food probe misuse (for example, wire pulled or squeezed) -Connector failure -Probe failure -PCB failure	Cycle on going: the cycle goes on in probe mode if there is at least one of the food probe working. The cycle switches to time mode if none food probe is working During STANDBY: the cycle can be started Cycle start: only by time Call Service.	Check if the food probe are well connected on connectors Check if cable of sensor n°1 is well connect in the connectors Change position of sensor n°3 or n°6 (depend how many sensors has the food probe installed) instead of sensor n°1, and change parameter nFp from 3 to 2 or from 6 to 5 Replace the food probe If even replacing the food probe the alarm persists, replace the PCB



Anomaly	Type of anomaly	Description	Possible causes	Instructions to User	Service Action (phase# refers to Service Manual)
<p>Eprb2</p>	<p>ALARM</p> <p>Blocking food probe cycles only if the entire sensor is faulty</p>	<p>Core probe failure sensor n°2</p>	<p>-Food probe misuse (for example, wire pulled or squeezed)</p> <p>-Connector failure</p> <p>-Probe failure</p> <p>-PCB failure</p>	<p>Cycle on going: the cycle goes on in probe mode if there is at least one of the food probe working.</p> <p>The cycle switches to time mode if none food probe is working</p> <p>During STANDBY: the cycle can be started</p> <p>Cycle start: only by time</p> <p>Call Service.</p>	<p>Check if the food probe are well connected</p> <p>Check if cable of sensor n°2 is well connect in the connectors</p> <p>Change position of sensor n°3 or n°6 (depend how many sensors has the food probe installed) instead of sensor n°2, and change parameter nFp from 3 to 2 or from 6 to 5</p> <p>Replace the food probe</p> <p>If even replacing the food probe the alarm persists, replace the PCB</p>
<p>Eprb3</p>	<p>Blocking food probe cycles only if the entire sensor is faulty</p>	<p>Core probe failure sensor n°3</p>	<p>-Food probe misuse (for example, wire pulled or squeezed)</p> <p>-Connector failure</p> <p>-Probe failure</p> <p>-PCB failure</p>	<p>Cycle on going: the cycle goes on in probe mode if there is at least one of the food probe working.</p> <p>The cycle switches to time mode if none food probe is working</p> <p>During STANDBY: the cycle can be started</p> <p>Cycle start: only by time</p> <p>Call Service.</p>	<p>Check if the food probe are well connected</p> <p>Check if cable of sensor n°3 is well connect in the connectors</p> <p>change parameter nFp from 3 to 2 or from 6 to 5</p> <p>Replace the food probe</p> <p>If even replacing the food probe the alarm persists, replace the PCB</p>
<p>Eprb4</p>	<p>Blocking food probe cycles only if the entire sensor is faulty</p>	<p>Core probe failure sensor n°4</p>	<p>-Food probe misuse (for example, wire pulled or squeezed)</p> <p>-Connector failure</p> <p>-Probe failure</p> <p>-PCB failure</p>	<p>Cycle on going: the cycle goes on in probe mode if there is at least one of the food probe working.</p> <p>The cycle switches to time mode if none food probe is working</p> <p>During STANDBY: the cycle can be started</p> <p>Cycle start: only by time</p> <p>Call Service.</p>	<p>Check if the food probe are well connected</p> <p>Check if cable of sensor n°4 is well connect in the connectors</p> <p>Change position of sensor n°6 instead of sensor n°4, and change parameter nFp from 6 to 5</p> <p>Replace the food probe</p> <p>If even replacing the food probe the alarm persists, replace the PCB</p>
<p>Eprb5</p>	<p>Blocking food probe cycles only if the entire sensor is faulty</p>	<p>Core probe failure sensor n°5</p>	<p>-Food probe misuse (for example, wire pulled or squeezed)</p> <p>-Connector failure</p> <p>-Probe failure</p> <p>-PCB failure</p>	<p>Cycle on going: the cycle goes on in probe mode if there is at least one of the food probe working.</p> <p>The cycle switches to time mode if none food probe is working</p> <p>During STANDBY: the cycle can be started</p> <p>Cycle start: only by time</p> <p>Call Service.</p>	<p>Check if the food probe are well connected</p> <p>Check if cable of sensor n°5 is well connect in the connectors</p> <p>Change position sensor n°6 instead of sensor n°5, and change parameter nFp from 6 to 5</p> <p>Replace the food probe</p> <p>If even replacing the food probe the alarm persists, replace the PCB</p>



Anomaly	Type of anomaly	Description	Possible causes	Instructions to User	Service Action (phase# refers to Service Manual)
 Eprb6	Blocking food probe cycles only if the entire sensor is faulty	Core probe failure sensor n° 6	-Food probe misuse (for example, wire pulled or squeezed) -Connector failure -Probe failure -PCB failure	Cycle on going: the cycle goes on in probe mode if there is at least one of the food probe working. The cycle switches to time mode if none food probe is working During STANDBY: the cycle can be started Cycle start: only by time Call Service.	Check if the food probe are well connected Check if cable of sensor n°5 is well connect in the connectors Change position change parameter nFp from 6 to 5 Replace the food probe If even replacing the food probe the alarm persists, replace the PCB
 B4	ALARM	Supply power missing	-Power supply missing -Supply power system failure -Other electrical issues (for example current dispersions)	Cycle on going: the cycle restart automatically when the power is back. The machine was not in operation for a certain time: check initial and end time. -Check the plug or general electric control panel. -If the alarm reoccurs, call service.	-Check in the log -Check the mains -Check the parameter of power failure PFt is properly set (too small): adjust if needed -Check the power cable if damaged: replace if needed -Check if any current dispersions which may cause the RCI (Residual Current Interrupter) to trip: fix if needed
 Ertc	ALARM	Low battery	-Battery of Ui is low -Electronic board failure	Problem with battery of internal clock. Call service.	-Replace the battery present in the UI -If the problem persists, replace the user interface board
 ECHt	WARNING	Cavity high temperature	-Door left open -Food too hot in the cavity -Issue with parameter ady or with temperature measurement	The cavity temperature has exceeded the set limit, in addition to the signal delay time Cycle on going: the cycle goes on If the alarm persists even if the cavity temperature is low, call service	Check the parameter ady setting Check the value KHOM of probe Check the heater(s) is(are) OFF Check the relay heater(s) Check the Parameter HAc and afd with correct value
 E11	ALARM Blocking machine	Compressor failure	-Fan condenser obstruction -compressor damage	The chiller will be blocked and only fan condenser run Check if there is some obstruction of suction air condenser Call service	Check if the contact of thermic protection (close compressor ON /open compressor OFF) By pass the thermic protection Change compressor Check if the fan condenser run Check is if solenoid valve is active Check if oil in the compressor Check if the compressor is ventilated Check if valves compressor are open
 B2	ERROR	Door open	The door remained open beyond the time limit set whit the active cycle	-Ensure the chiller door is closed and any physical obstruction is not preventing the door closure. -Start new cycle: if either a new cycle will not start or the alarm persists even with the door closed, call Service	-Check the door micro-switch connections -Check the position of door micro switch and the door magnet -Check the door alignment -Check if the parameter of the delay time for the door is correctly set
 ACUP	ALARM	ACU Protocol error	- ACU board not programmed or programmed with an incompatible SW version -Electronic boards disconnected	Communication protocol error detected. If the problem persists, call service	-Suggest to switch the machine OFF/ON for resetting the alarm. If the alarm persists upload SW using USB Key: be sure to program both User interface and ACU board
Display is OFF while main switch button is ON			Connector to display disconnected	Switch the unit Off/On; if the problem persists call service	Check the connection on UI; if needed replace UI
Display is stuck on screen saver and does not react			Issue with the SW	Switch the unit Off/On; if the problem persists call service	Re-upload the SW
Display shows condensation inside			Infiltration of water during the cleaning	No actions required in case it is possible to continue operating with the unit. If any problem operating with the unit, call service.	Replace the control panel



Anomaly Type of anomaly	Description	Possible causes	Instructions to User	Service Action (phase# refers to Service Manual)
External noise/vibrations with cycle ON		Unit unlevelled Condenser water tray and guide damage Condenser panel not fix well	Level the unit with the adjustable feet Adjust the guide or remove the condenser water tray Check if the condenser panel is fixed correctly Call service if the problem persists	Check the screws of feet are fixed Check if the water tray guide are bended, in case replace them Check the screws of panel are fixed and the panel are inserted on its position
Internal noise/vibrations with cycle ON		The shelf guide is not allied The rack support is not well positioned Obstruction of cavity fan Carter/deflector evaporator fan not fix well	Check if the right/left guide are well positioned Check if the right/left rack support is well fixed, top and bottom Check if the cavity fan working well without any obstructions Check if present the screws on carte evaporator If the problem persists call service	In the staking kit with oven over the BCF, check if side, frontal, panel are well installed Check if the cavity fan are fixed to the fan protection grid, and that inside of carter are not obstruction Check all components in the back side of the unit are well fixed or some pipe does not touch other components
The unit needs too much time to arrive at set temperature		<ul style="list-style-type: none"> - Excessive food loaded in the cavity - Refrigerant gas leakage - Cavity fan with 3 phase has wrong rotation or not connected - Thermostatic valve not set - Compressor damaged valve - Relay of heating element stuck - Insulation of pipes and wires on the rear side is missing or damaged 	<ul style="list-style-type: none"> - Reduce the amount of food loaded in the cavity and/or use different pan types. - If the problem persists call service 	<ul style="list-style-type: none"> -Check that the lack of performance is not due to excessive or wrong load of the food in the cavity. -Identification leakage with gas detector -Check the connection power of the fan and in case change the phase in the main control power connection -Adjust the valve following chapter of "thermostatic valve" -Check the pressure HP and LP, and if they are equal change compressor -Check the relay/contactator, and in case replace the components -Check the back insulation on pipe and wiring cable, if result insufficient add other coibentation
The compressor does not start		<ul style="list-style-type: none"> -No electrical power -Oil safety switch open or current safety switch open -Electrical connections loose or defective -Motor burnt 	Call service	<ul style="list-style-type: none"> -Check phases, connections and switches: fix if needed -Manually reset -Check the connection with the correct diagram and tighten the connections if needed -Check and replace the compressor if needed
Switch Button ON_OFF not working		Electric supply issue Hardware issue Wiring issue	Switch the unit Off/On; if the problem persists call service	Check main electric supply and if any issue due to external spikes or fluctuations Check electric connections and wires: fix if needed Replace the fuse if needed Replace the UI if needed Replace the PCB if needed
The compressor oscillates intermittently		Suction service valve closed Discharge service valve closed Refrigerant load insufficient Wrong operation of the low pressure switch Condenser insufficient or dirty Air in the circuit Intervention motor protection	Call service	Open the service valve Add gas Check the setting and the assembly of the low pressure switch Check the flow rate of air or water to the condenser. Clean the condenser Make a total vacuum Check that the quantity of refrigerant is sufficient. Check electrical connections



Anomaly Type of anomaly	Description	Possible causes	Instructions to User	Service Action (phase# refers to Service Manual)
The compressor oscillates continuously		Defective pressure switches Refrigerant load and discharge pressure too high Blocked dehydrators filters	Call service	Repair or replace Remove excess refrigerant Replace filters
Decrease in compressor efficiency		Leakages from the valves or dirty valve plate; breakage of valves Leakage from internal safety valve Leakage from the gasket of the head Piston rings wear	Call service	Disassemble the heads and check the valve plate and the valves Replace the safety valve Replace the gasket Replace the compressor
Leakage from the gasket of the head		Heads bolts not enough tighten	Call service	Replace the gasket and tighten bolts again
Presence of liquid in the carter		Piping not properly designed The defrost cycle does not work correctly Wrong calibration of the expansion valve The evaporator does not work	Call service	Correct piping Check the defrost cycle Replace the valve or change the calibration Check the evaporator condition
High pressure too low		The discharge valve are not gastight Crankcase heater does not work The piston rings are worn	Call service	Disassemble the heads and check the valve plate and the valves Replace the heater Replace the compressor
Low suction pressure		Quantity of refrigerant insufficient Problems with evaporator fans Dehydrators filters dirty	Call service	Add gas Check Replace filters
Compressor noises		Beats due to excess of oil inside the compressor Beats due to liquid in the compressor Bearings and/or other components worn	Call service	Remove the excess of oil See the failure : Presence of liquid in the carter Replace the compressor Compressor not assembled properly
Insufficient oil pressure or low oil level		Lack of oil Oil pump broken Bearing too worn Piping does not guarantee enough return oil return Oil filter dirty	Call service	Add oil Replace it Replace the compressor Check the layout pipes Replace the filter
Intervention of the protection of the compressor		Too high discharge pressure Relay defective High suction temperature Low suction pressure Power or control circuit connections loosened Defective motor	Call service	Check the condenser is working properly Replace it Reduce the suction temperature See the failure : Low suction pressure Check all connections Replace the compressor
The compressor run with locked rotor amps		Low power supply or mistake in the connections The compressor is blocked The motor is defective Lake of one phase	Call service	Check the supply tension Replace it Check the windings Check the tension on the terminals
Motor burnt out		Check the welded power and/or control contacts to identify the burnt out parts	Call service	Replace the defective parts and the compressor
The temperature of the compressor is too high		Compression ratio too high	Call service	Check the pressure switches, that the condenser is clean and motors fans



6. SERVICING THE APPLIANCE

6.1 LIST OF NEEDED TOOLS

List of needed tools Please, refer to the Electrolux Professional Universal Spare Parts Catalogue [usp]..

6.1.1 Ordinary Tools

The following tools take part of the Kit of assorted tools [usp #0S1288] contained in the Tool trolley case [usp #0S1980]

6.1.2 Special Tools: List, Description And Spare Part Code Per Each Special Tool

In addition to the normal instrumentation, to do the maintenance of this unit the following tools are recommended:

- Drill screwdriver
- Digital multimeter [usp #0S1282].
- Current clamp [usp #0S1456]
- Digital manometer gas pressure and temperature [usp #0S1127]
- Refrigerant gas leakage HFC
- Pipe for digital manometer gas pressure and temperature
- Nitrogen kit clean and pressure
- Welding torch
- Evacum pump with manometer
- Keys for discharge and suction service valve compressor

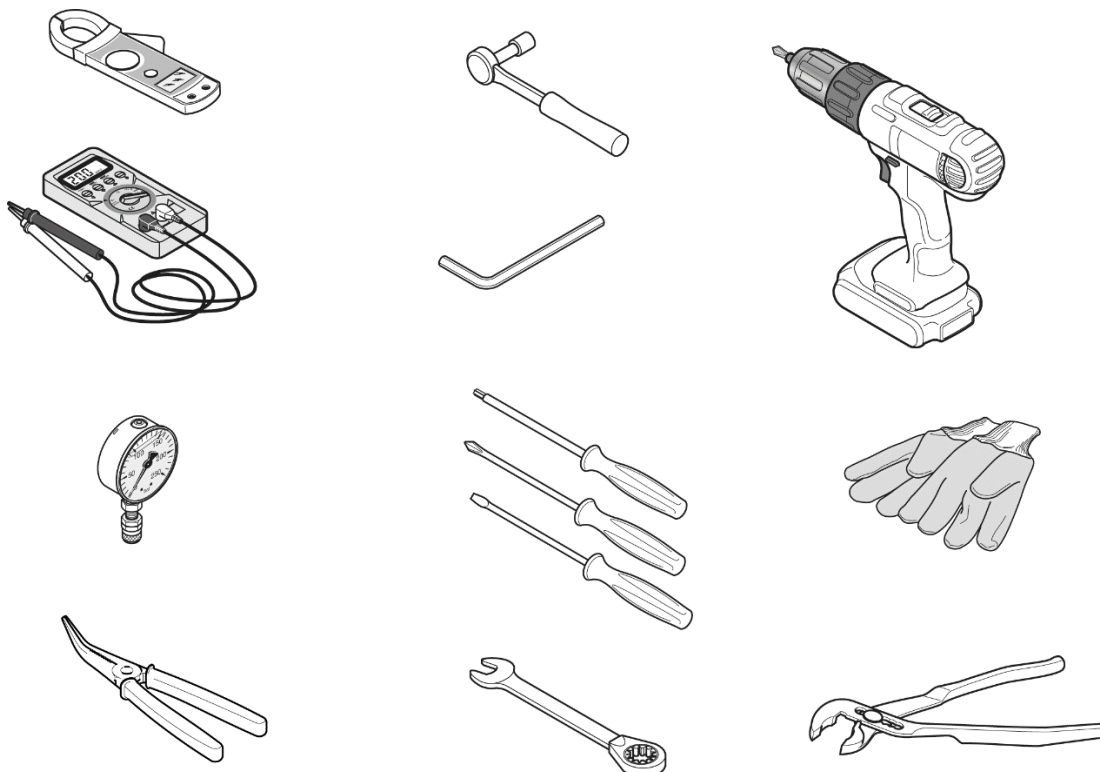



6.2 IMPORTANT PROCEDURES FOR INSTALLATION



ATTENTION!

When performing the procedures to replace the components of the cooling circuit, pay attention to some important precautions, so as to avoid the contamination of the refrigeration systems.

6.2.1 Storage of components

The temperature of all components, before their removal from the packaging and installation, must be no lower than the ambient temperature. This prevents the formation of condensation in the components.

These, for example, must not be installed immediately after being transferred from a cold service vehicle to a room with a higher temperature.



6.2.2 Cleaning the pipes

Very damaging impurities:

- Humidity
- Atmospheric air
- Brazing residues
- Rust, copper oxide, slag
- Metal shavings
- Unstable oils
- Some fluorinated solutions
- Impurities and dust of all kinds.

As to cleaning, blow a strong blast of dry compressed air or nitrogen into the pipe.

Never use normal compressed air, due to its high moisture content. Never blow into the pipe with your mouth.

The presence of small amounts of moisture in the components can be eliminated by proceeding simultaneously with the heating and introduction of dry nitrogen.

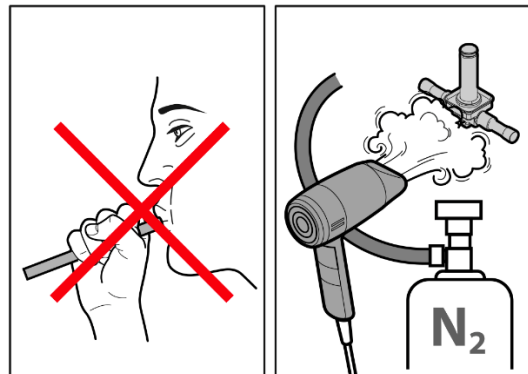

6.2.3 Installation of refrigeration system components

In installing the system components it is advisable to proceed as quickly as possible, in order to minimize the action of humidity.

During the breaks in the installation, it is absolutely necessary to hermetically close all the openings of the refrigerating system in order to prevent air from entering and humidity from forming.



6.3 REPLACING EQUIPMENT COMPONENTS

6.3.1 Disassembly/Reassemble Of Components Range 50_70 Kg

6.3.1.1 Accessing the components on the back side of the appliance

Ensure enough space around the appliance when operating on the back side.

1. Unscrew the four screw of the back spacer to remove it (Fig. 1).
2. Unscrew the ten screws of the protection grid to remove it (Fig. 2).
3. Find the wiring harness cover underneath the chamber and open it. Release the adjustable cable ties and cut the rest of the cable ties to release the wiring (Fig. 3).

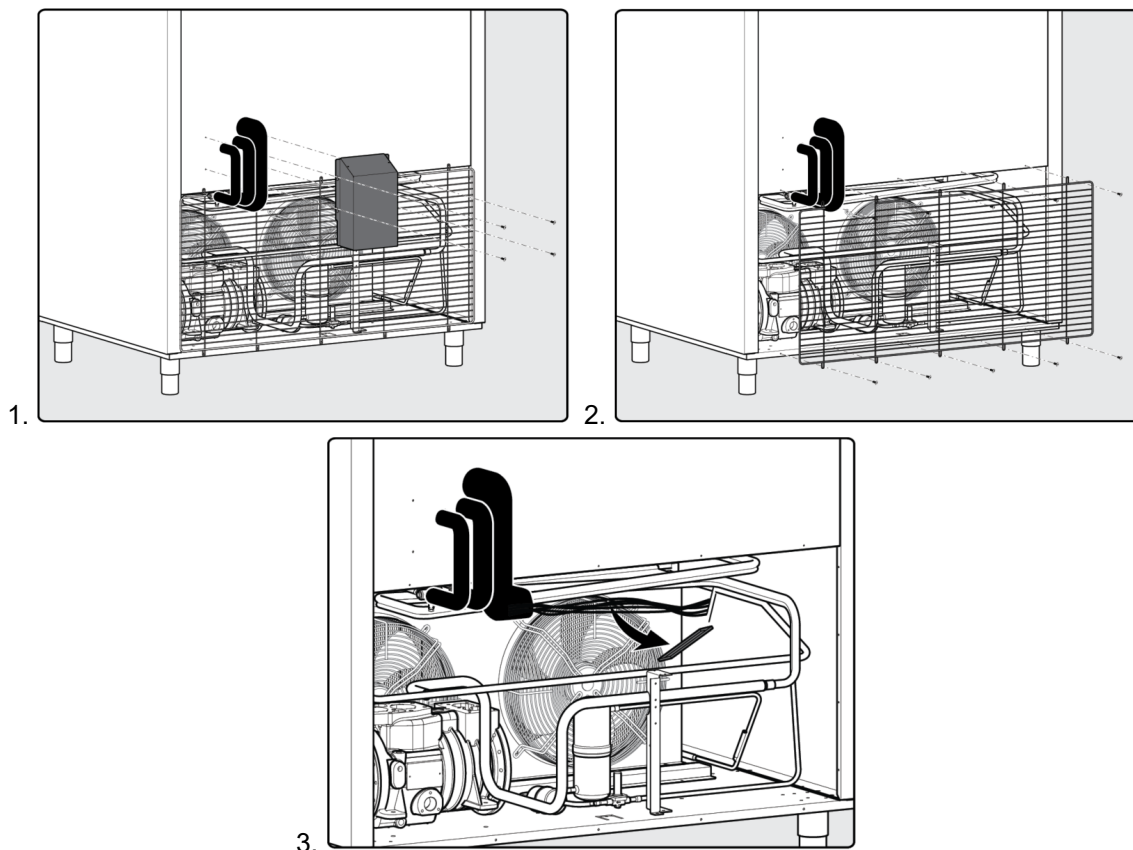

6.3.1.2 Rack supports

1. Unscrew the lock nut from the front left rack support (Fig. 1).
2. Release the spring on the top of the front left rack support (Fig. 2).
3. Remove the left rack support: lift then rotate the left rack support by pulling it from the lower side (Fig. 3).
4. Move down the lock on the top of the right rack support (Fig. 4).
5. Remove the right rack support: lift then rotate the left rack support by pulling it from the lower side (Fig. 5)

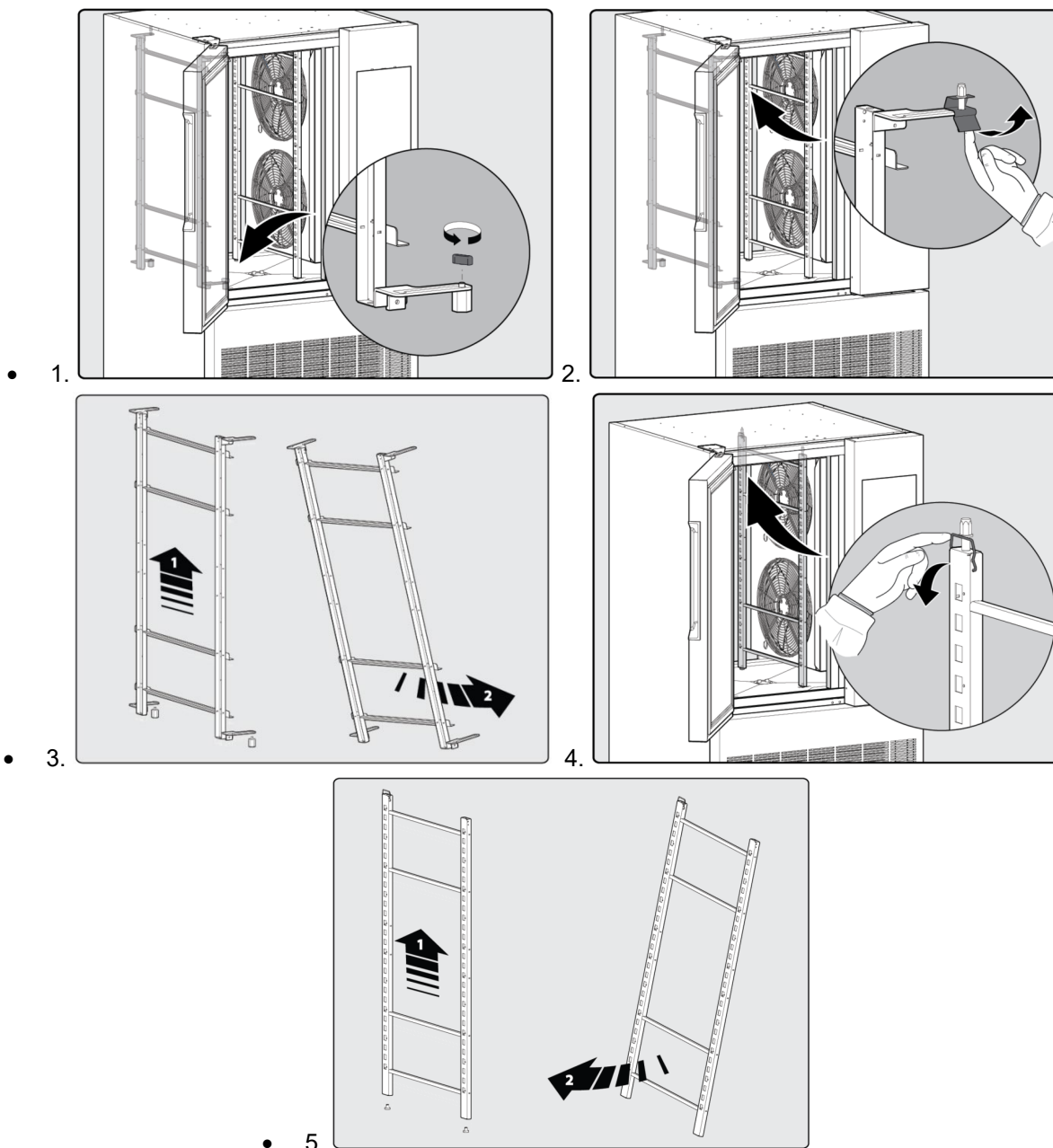

6.3.1.3 Cell probe (blue)

The cell probe is located inside the chamber, fixed on the fan protection grid.

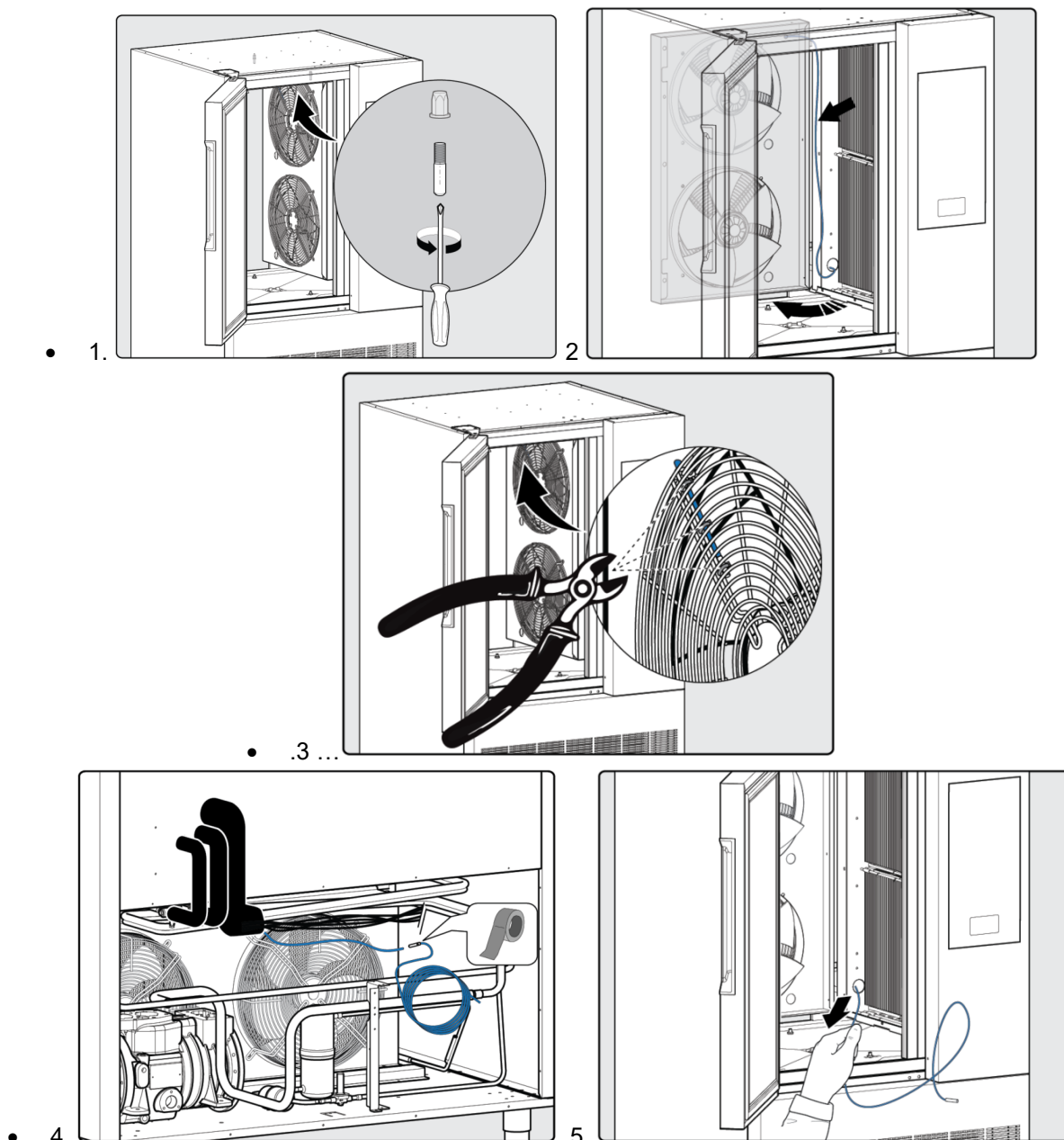

1. Follow the procedure in paragraph [Rack support], sequence 1 and 5.
2. Find the cell probe on the fan protection grid and cut the cable ties to release the probe (Fig. 1).
3. Open the evaporator conveyor, find the wire of the cell probe (Fig. 2).
4. Pull out the sensor of the cell probe from its position.
5. Follow the procedure in paragraph [Accessing the components on the back side of the appliance] to reach the connector of the cell probe and disconnect it.
6. Using an adhesive tape, fix the end of the probe to the sensor of the new probe (Fig. 4).
7. On the side of the cell, pull out completely cable of the old cell probe up to appear the sensor of the new cell probe (Fig. 5).
8. Fix the sensor of the new cell probe in the same position on the fan protection grid.
9. Use cable ties to restore the wiring layout.
10. Reassemble all the removed components following the inverse procedure.



6.3.1.4 Evaporator probe (grey)

1. Follow the procedure in paragraph [*rack support and cell probe 1 to 2*].
2. Open the evaporator conveyor, find the evaporator probe and pull out carefully the sensor from its position (Fig. 3).
3. Follow the procedure in paragraph [*Accessing the components on the back side of the appliance*] to reach the connector of the evaporator probe and disconnect it.
4. Using an adhesive tape, fix the end of the probe to the sensor of the new probe (Fig. 2).
5. On the side of the cell, pull out completely cable of the old cell probe up to appear the sensor of the new cell probe (Fig. 3).
6. Insert the sensor of the new cell probe in the same position on the evaporator (approx. 50 mm distance from the upper edge and left edge).
7. Use cable ties to restore the wiring layout.
8. Reassemble all the removed components following the inverse procedure.

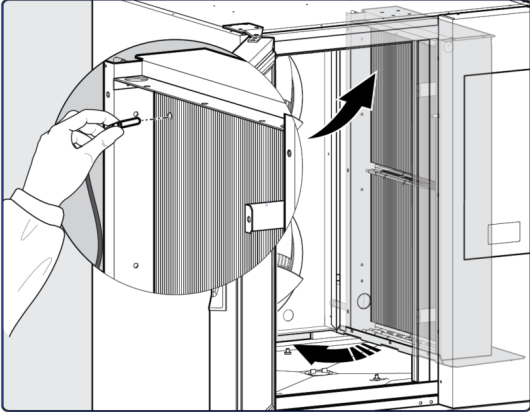
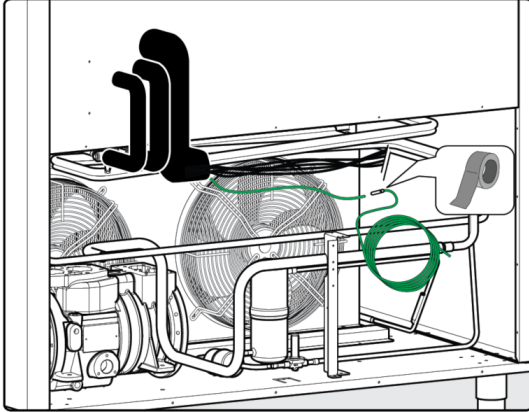

1. 
2. 
- 3. 



6.3.1.5 Food probe

1. Follow the procedure in paragraph [rack support and cell probe 1 to 2].
2. Open the evaporator conveyor and unscrew the two screws shown in figure 1 to remove the wiring cover.
3. Unsnap the rubber fairlead to ease the passage of the probe connector.
4. Follow the procedure in paragraph [Accessing the components on the back side of the appliance] to reach the connector of the food probe to be replaced and disconnect it.
5. Fix the connector of the food probe to be replaced to a fairlead probe using an adhesive tape (Fig. 2).
6. On the cell side, pull out completely the wiring of the food probe up to appear the fairlead probe (Fig. 3).
7. Fix the connector of the new food probe to the fairlead probe using an adhesive tape (Fig. 4).
8. On the rear side of the appliance, pull out completely the fairlead probe up to the appear the connector of the food probe (Fig. 5).
9. Connect the new food probe to the same connector of the replaced food probe.
10. Use cable ties to restore the wiring layout.
11. Reassemble all the removed components following the inverse procedure.

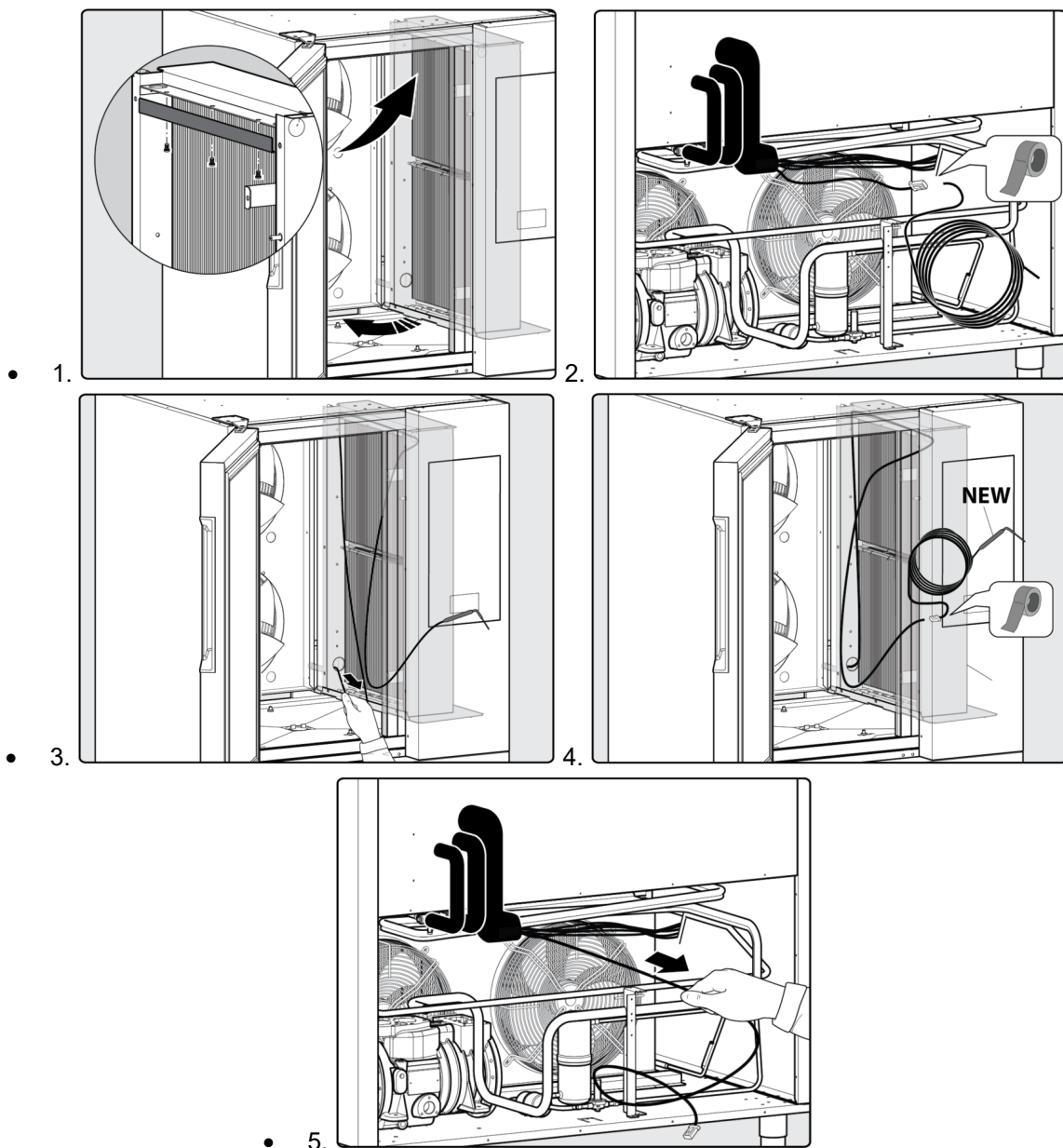



6.3.1.6 Condenser probe (black)

1. Follow the procedure in paragraph [Accessing the components on the back side of the appliance] to reach the connector of the condenser probe and disconnect it.
2. Pull out the condenser probe from its position (Fig. 1).
3. Insert the sensor of the new condenser probe into the seat.
4. Use cable ties to restore the wiring layout.
5. Reassemble all the removed components following the inverse procedure.

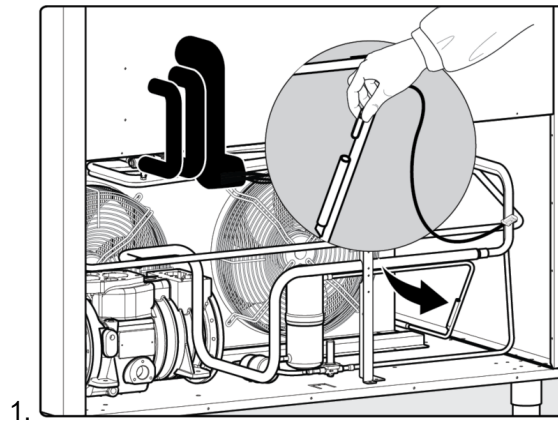

6.3.1.7 Outevaporator probe (green)

1. Follow the procedure in paragraph [Accessing the components on the back side of the appliance] to reach the connector of the suction probe and disconnect it.
2. Cut the insulation near the expansion valve to reach the suction probe.
3. Unscrew the clamp of expansion valve sensor to release the suction probe sensor, then pull out the suction probe sensore (Fig. 1).
4. Insert the sensor of the new suction probe into the seat (Fig. 2), then tighten the screw of the clamp. Do not overtighten the screw in order to prevent any damage to the sensors.
5. Restore the insulation accurately. Use a cable tie to fix the insulation and the suction probe (Fig. 3).
6. Use cable ties to restore the wiring layout.
7. Reassemble all the removed components following the inverse procedure.

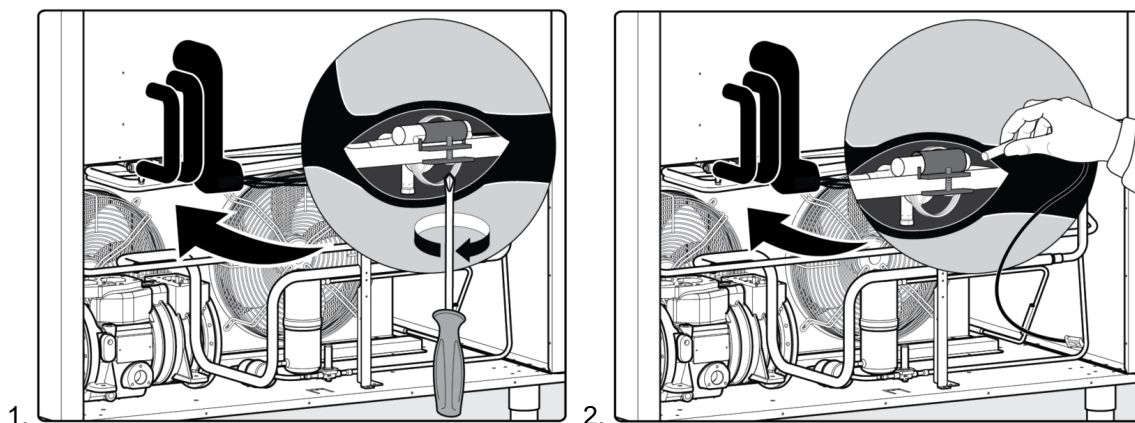

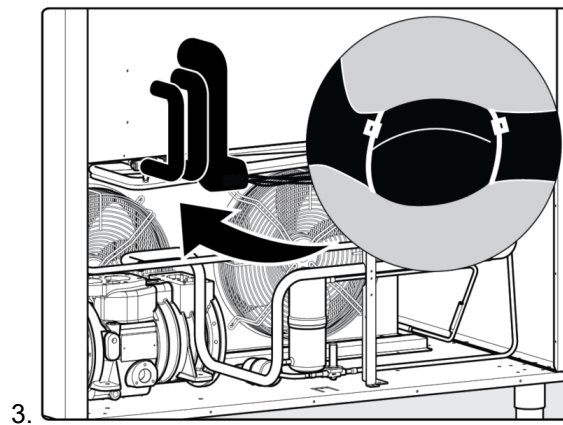

3.

6.3.1.8 Thermostat

1. Follow the procedure in paragraph [rack support and cell probe 1 to 2].
2. Open the evaporator conveyor and unscrew the nut shown in figure 1 to release the thermostats.
3. Release the adjustable cable ties and cut the rest of the cable ties to release the wiring.
4. Disconnect the connector of the thermostat and replace it with the new one.
5. Use cable ties to restore the wiring layout.
6. Reassemble all the removed components following the inverse procedure.

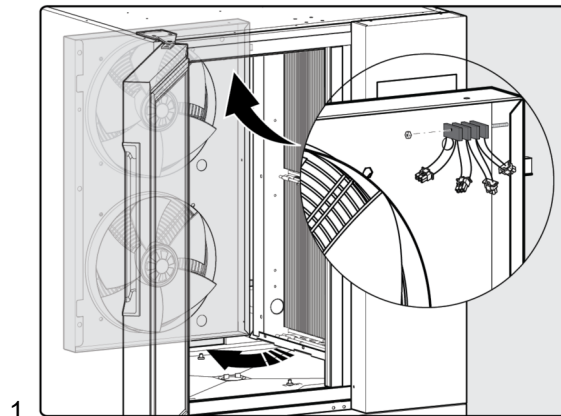

1.

6.3.1.9 Evaporator fan

1. Follow the procedure in paragraph [rack support and cell probe 1 to 2], sequence.
2. Unscrew the two screws of the evaporator conveyor. The front deflector will be disassembled as well (Fig. 2).
3. Open the evaporator conveyor, release the adjustable cable ties and cut the rest of the cable ties to release the wiring.
4. Follow the procedure in paragraph [Accessing the components on the back side of the appliance] to reach the connectors of the evaporator fans to be replaced and disconnect them.
5. Fix the one connector of the evaporator fan to be replaced to a fairlead probe using an adhesive tape (Fig. 3).
6. On the cell side, pull out completely the wiring of the evaporator fan up to appear the fairlead probe (Fig. 4).
7. Unscrew the four screws of the fan grid to release the grid and the fan (Fig. 5).
8. Install the new evaporator fan following the inverse procedure. Make sure to pass the wiring of the new fan through the fairlead on the evaporator conveyor.
9. Fix the wiring to the fairlead probe using an adhesive tape (Fig. 6).
10. On the rear side of the appliance, pull out completely the fairlead probe up to the appear the connectors of the evaporator fan (Fig. 7).
7. Connect the wiring of the new fan to the same connectors of the replaced fan.
8. Use cable ties to restore the wiring layout.



9. Reassemble all the removed components following the inverse procedure.

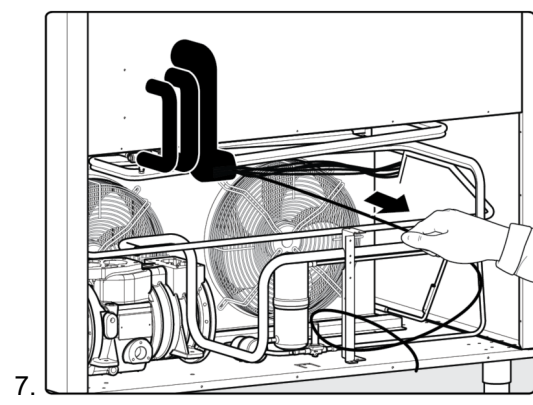
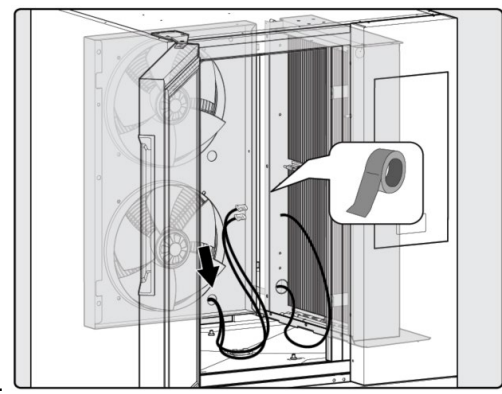
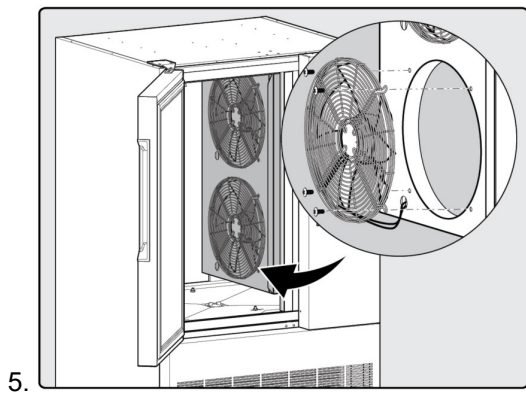
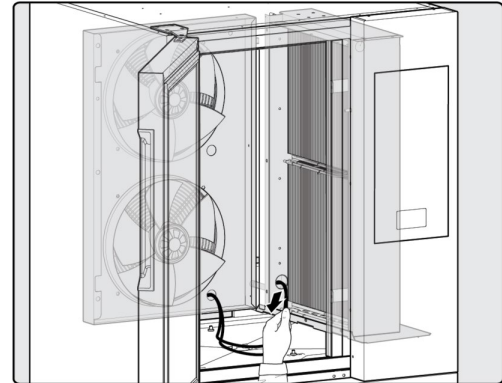
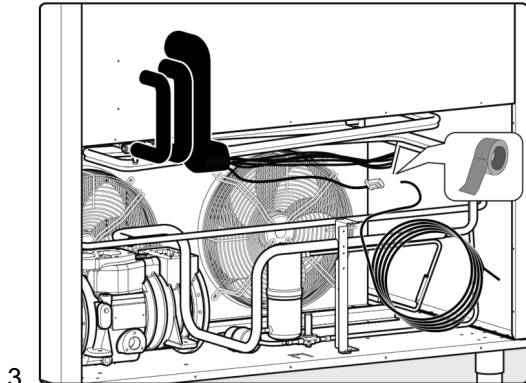
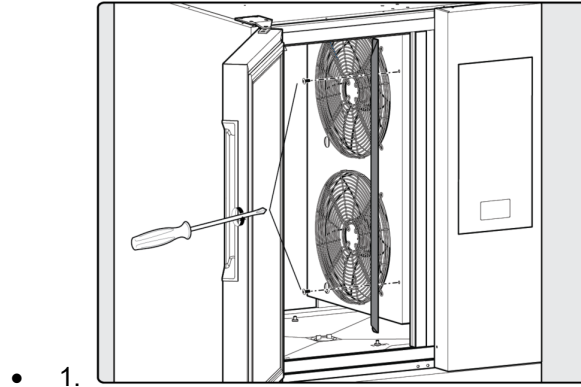



6.3.1.10 Heating element

1. Follow the procedure in paragraph [rack support and cell probe 1 to 2], sequence
2. Disconnect the connector from clixson to heating element.
3. Follow the procedure in paragraph [Accessing the components on the back side of the appliance] to reach the connectors of the heating element to be replaced and disconnect them.
4. Unscrew the screw of the bracket to release the heating element.
5. Remove the heating element first moving it forward into the slot, then pull the heating element out with a slight rotation (Fig. 1).
6. Fix the connector of the heating element to be replaced to a wiring guide using an adhesive tape
7. On the cell side, pull out completely the wiring guide up to appear the fairlead pipe
8. Install the new heating element following the inverse procedure.
9. Use cable ties to restore the wiring layout.
10. Reassemble all the removed components following the inverse procedure.

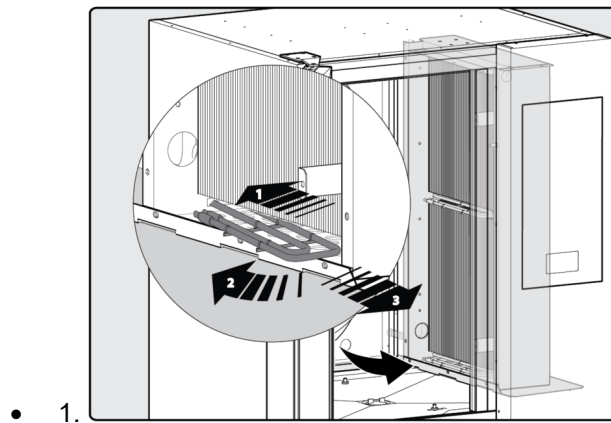

6.3.1.11 Comand Panel

- Open the flap of the USB port and unscrew the screw shown in figure 1.
- Pull the Comand Panel carefully to prevent any damage to the wiring.
- Use the two hooks on the left side of the Comand Panel to hang it on the Control Panel (Fig. 2).
- Unsnap the protection comand panel to access the electronic components.
- Disconnect all the connectors to release the Comand Panel.

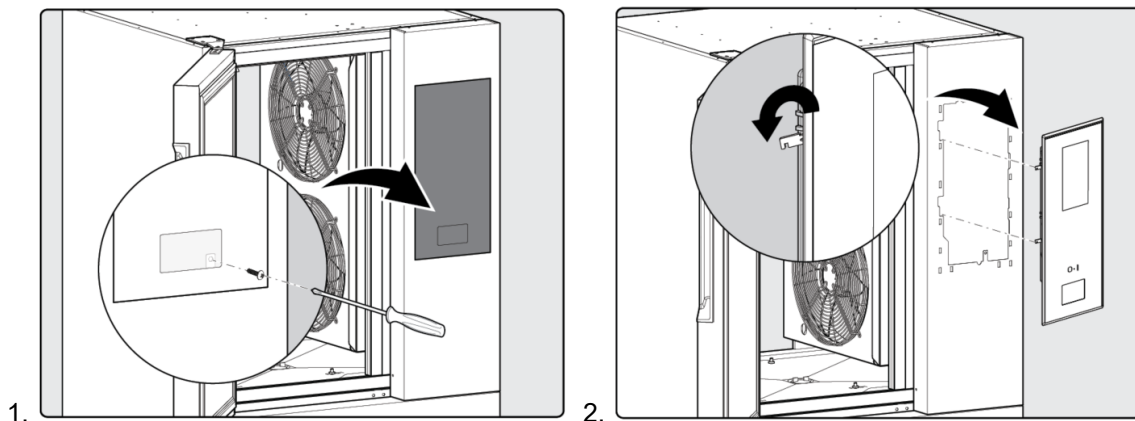



6.3.1.12 Control Panel

1. Follow the procedure in paragraph [Comand Panel], to remove the Comand Panel.
2. Unscrew the four screws shown in figure 1 to disassemble the control panel (2 screws on top, one on left side, one on right side).
3. Unscrew the nut shown in figure 2 to release the grounding connection.

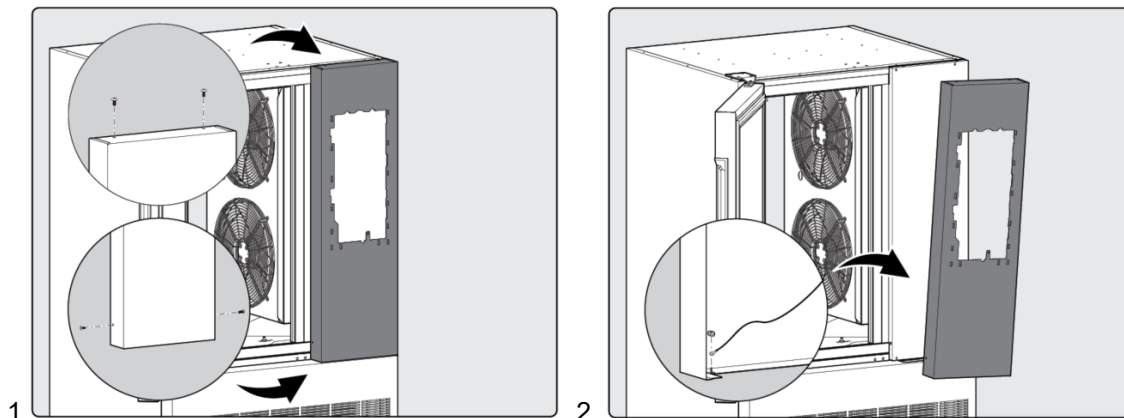

6.3.1.13 Frame heating element cable

1. Follow the procedure in paragraph [Comand Panel] to remove the Comand Panel.
2. Follow the procedure in paragraph [Control Panel] to remove the Control Panel.
3. Follow the procedure in paragraph [Electrical box] sequence 1 and 2 to remove the Condenser Panel.
4. Reach the connector of the heating element cable and disconnect it (Fig. 1).
5. Remove the magnetic cover: use a flat screwdriver to make lever on the upper part of the frame and unsnap a segment, then remove it completely by hand (Fig. 2).
6. Pull out the vertical segment of the heating element cable (Fig. 3).
7. Unscrew the six screws shown in figure 4 to disassemble the evaporator foamed panel.
8. Remove the rest of the magnetic covers (Fig. 5).
9. Pull out completely the heating element cable.
10. Install the new heating element cable following the inverse procedure. Refer to figure 6 for the correct layout of the heating element cable.
11. Reassemble all the removed components following the inverse procedure.

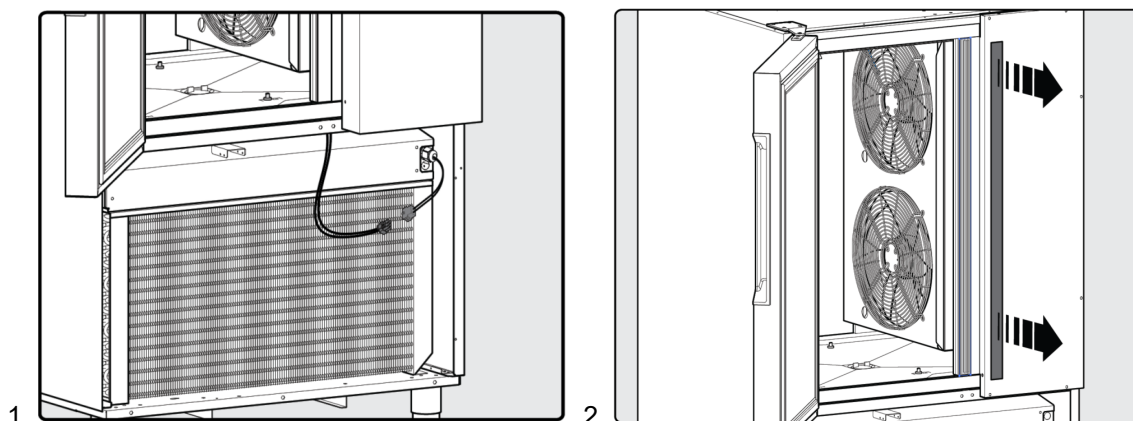

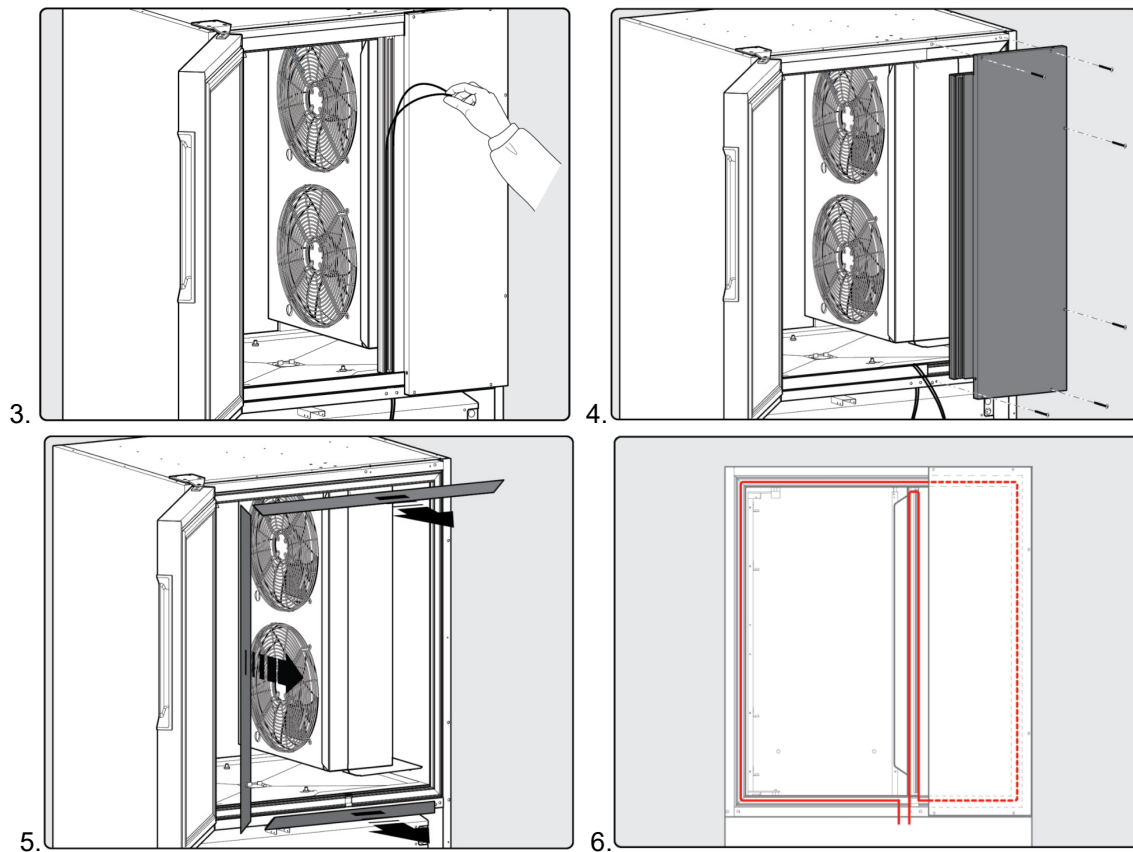

6.3.1.14 Evaporator

1. Follow the procedure in paragraph [rack support and cell probe 1 to 2], sequence
2. Lift the evaporator conveyor to remove it from the hinges and rest it carefully inside the cell (Fig.1).
3. Follow the procedure in paragraph [Heating element cable], sequence 1 to 7, to remove the control panel and the evaporator foamed panel.
4. Follow the procedure in paragraph [Heating element] to remove the heating element from the evaporator.
5. Follow the procedure in paragraph [Accessing the components on the back side of the appliance] to reach the connectors of the wiring of all the components inside the cell (food probes, cell, probe, evaporator probe, thermostats, fans) and disconnect them.
6. Fix the end of one cable to a fairlead probe using an adhesive tape (Fig. 2).
7. On the cell side, pull out completely the wiring up to appear the fairlead probe (Fig. 3).
8. Remove the food probes from the evaporator.
9. On the rear side of the appliance remove the insulation from the two pipes of the refrigerant circuit connected to the evaporator, then desolder the joints between the evaporator and the circuit (Fig. 4).
10. Unscrew the two screws shown in figure 5 to release the evaporator. Use a spacer underneath the evaporator to prevent it from dropping.
11. Pull out the evaporator with a slight rotation (Fig. 6).
12. Install the new evaporator following the inverse procedure.
13. Make sure that the fairlead probe passes through the proper fairlead on the evaporator then fix the wiring of all the components inside the cell to the fairlead probe using an adhesive tape (Fig. 7).
14. On the rear side of the appliance, pull out completely the fairlead probe up to the appear all the connectors of the wiring (Fig. 8).
15. Connect the wiring of the proper connectors.
16. Use cable ties to restore the wiring layout.
17. Restore the joint between the evaporator and the refrigerant circuit.
18. Restore the insulation of the pipes accurately.
19. Reassemble all the removed components following the inverse procedure.

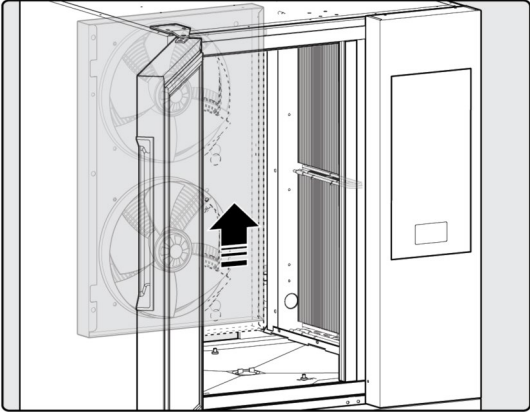
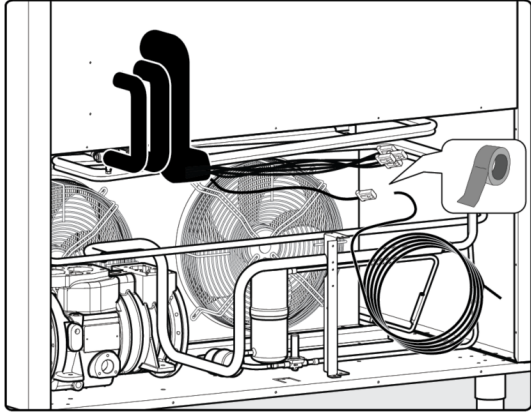
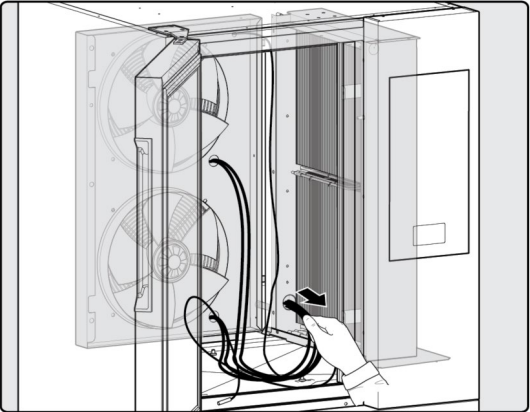
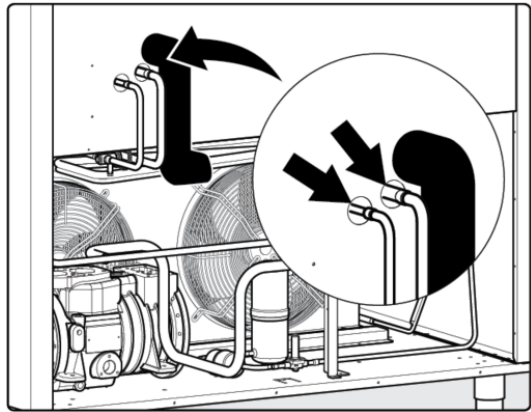
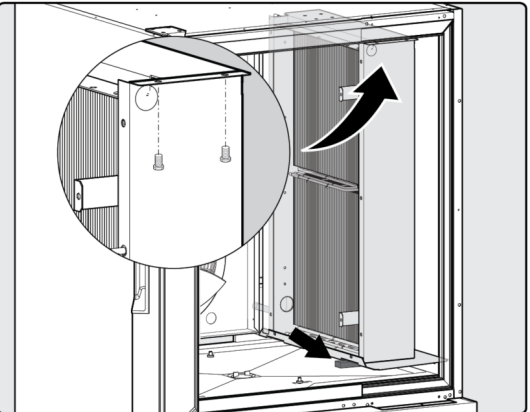
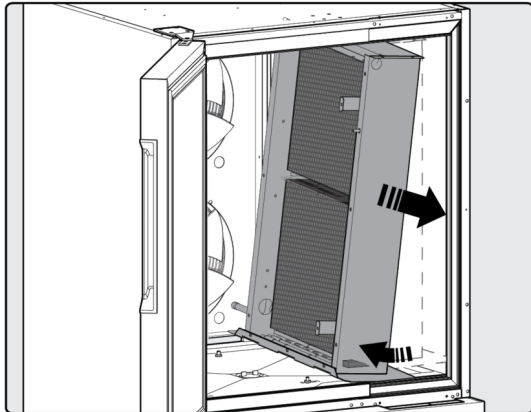
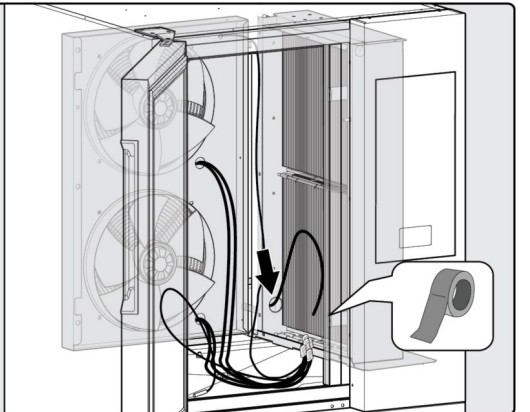
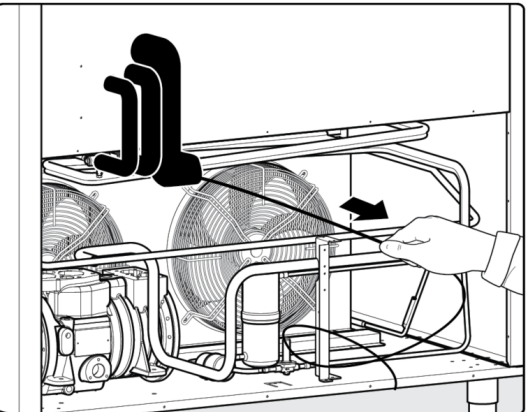

- 1. 
- 2. 
- 3. 
- 4. 
- 5. 
- 6. 
- 7. 
- 8. 



6.3.1.15 Electrical box

1. Unscrew the three screws on the lower side of the condenser panel (Fig. 1).
2. Remove the condenser panel: slide it slightly to right then pull (Fig. 2).
3. Slide out the electrical box by pulling it (Fig. 3).
4. Unscrew the four screws on the front side of the electrical box to remove the electrical box cover (Fig. 4).

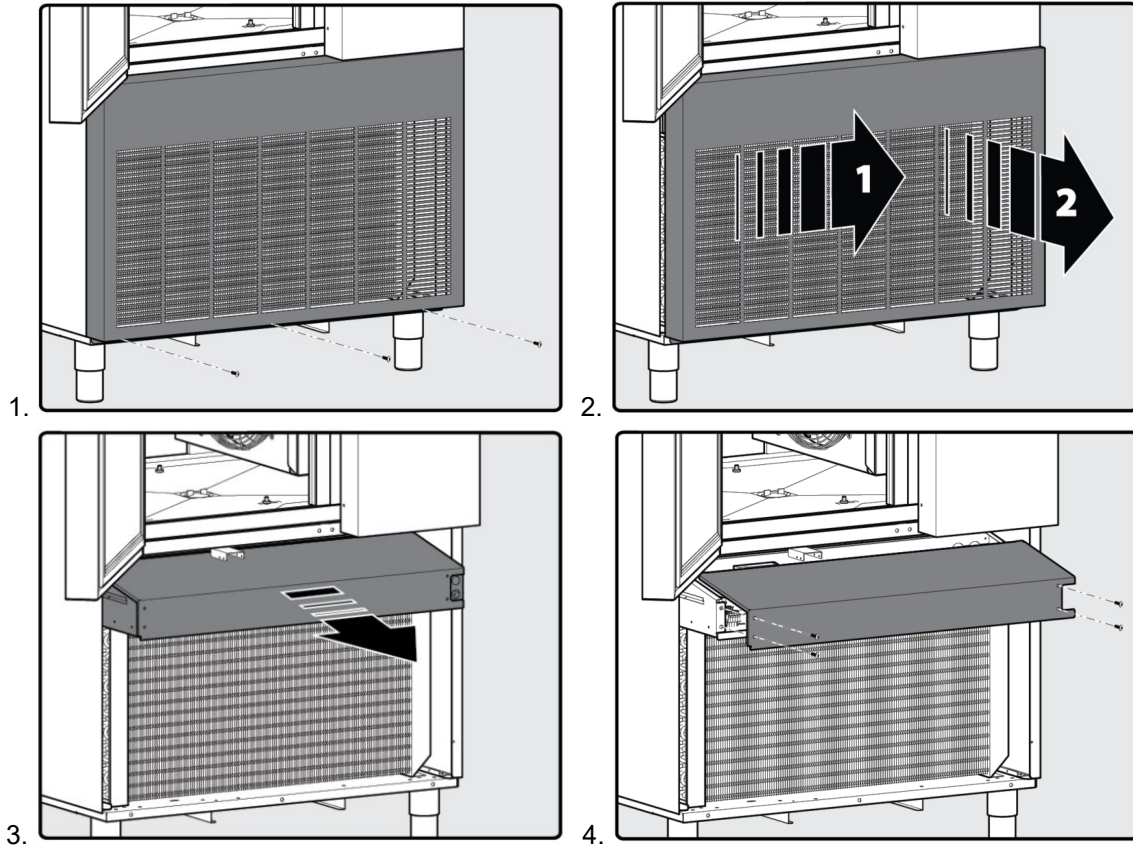



6.3.1.16 Compressor

1. Follow the procedure in paragraph [Accessing the components on the back side of the appliance] to reach the compressor.
2. Close the low pressure supply by screwing clockwise the valve, then wait for 10 minutes (Fig. 1).
3. Close the high pressure supply by screwing clockwise the valve.
4. Connect the vacuum pump and create vacuum in the compressor.
5. Shut down the power supply to the appliance.
6. Disconnect the wiring to the compressor.
7. Unscrew the two screws from each valve (low and high pressure) to release the compressor from the circuit (Fig. 2).
8. Unscrew the clamp and release the pipe of the refrigerant circuit from the support (Fig. 3).
9. Unscrew the four nuts at the basement of the compressor to release it from the chassis (Fig. 4).

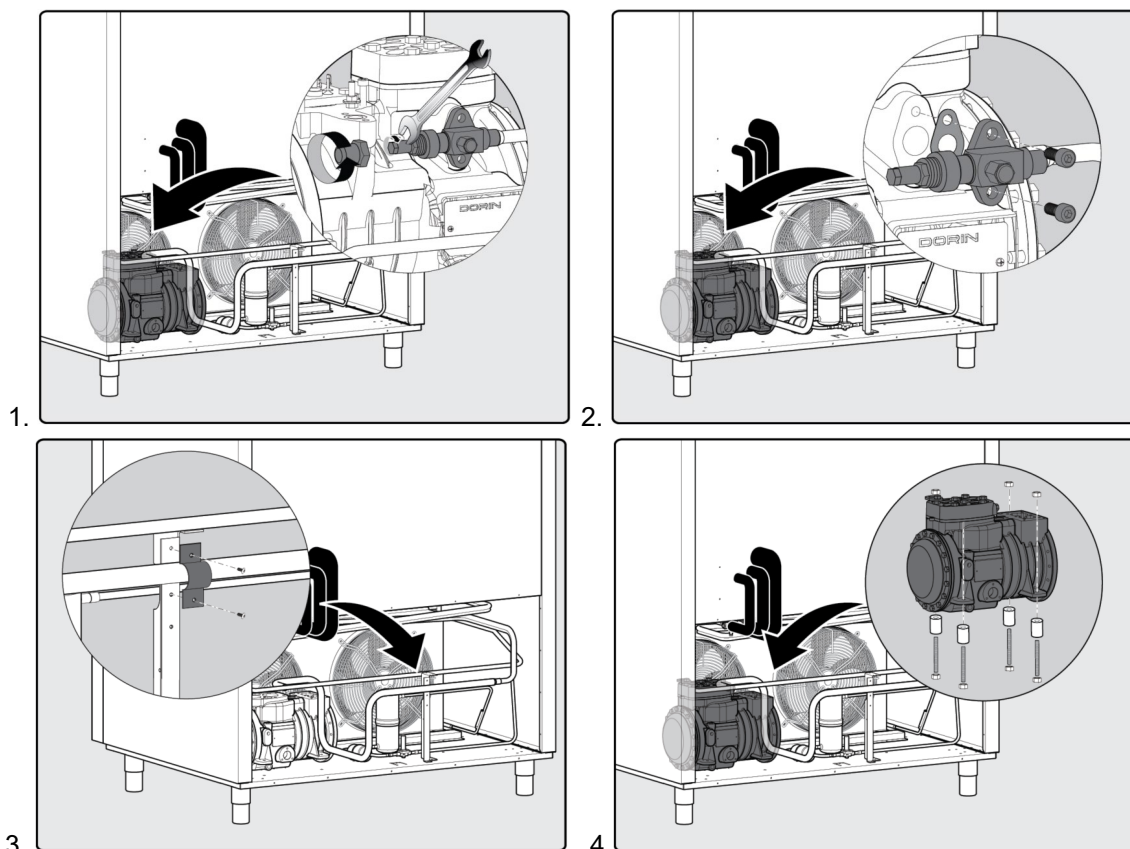



6.3.1.17 Solenoid valve

1. Follow the procedure in paragraph [Accessing the components on the back side of the appliance] to reach the solenoid valve.
2. Remove the screw of the power connector on the coil of solenoid valve (Fig. 1).
3. Remove the spring retaining coil and remove the coil upwards from body valve (Fig. 2).
4. Desolder the joints upstream and downstream of the valve.

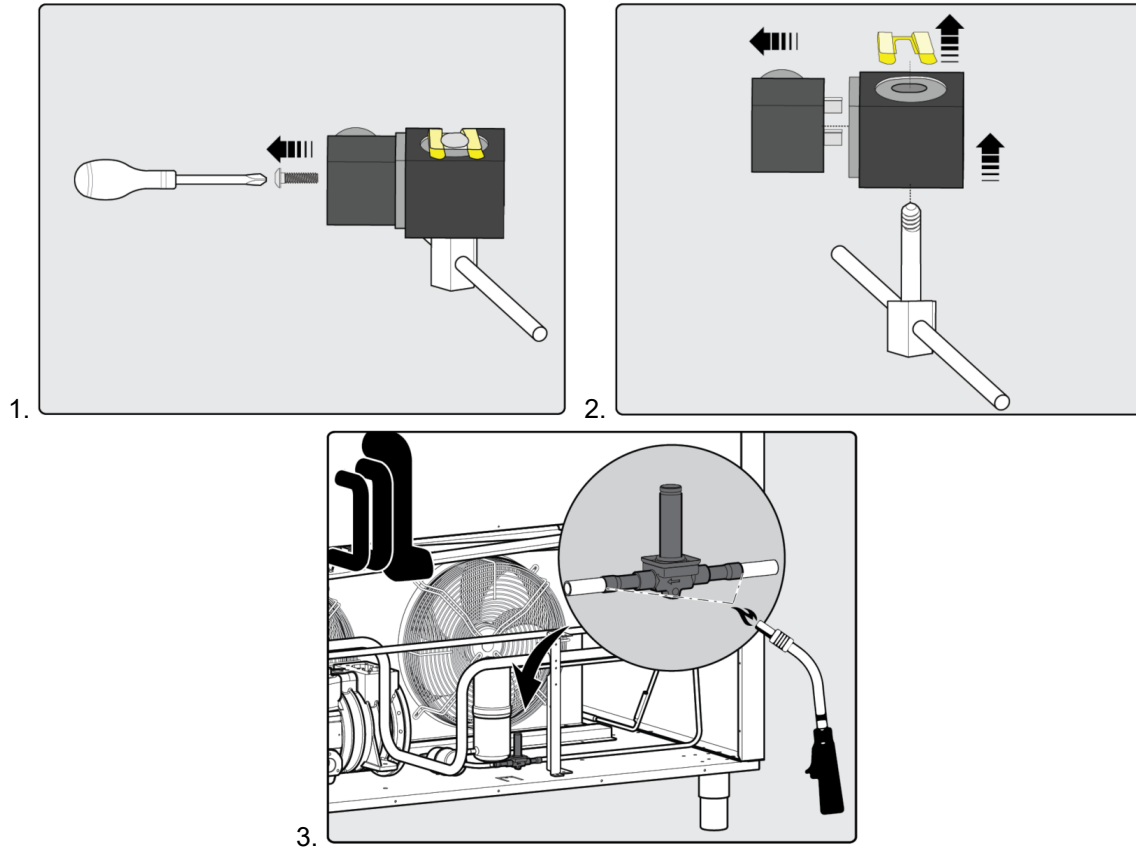

i Information: in the USA model only, there are two solenoid valves due to the gas pressure used (R448a) These valves are installed one a normal circuit (n°2) and the other used as by pass (n°1) always in the HP circuit.

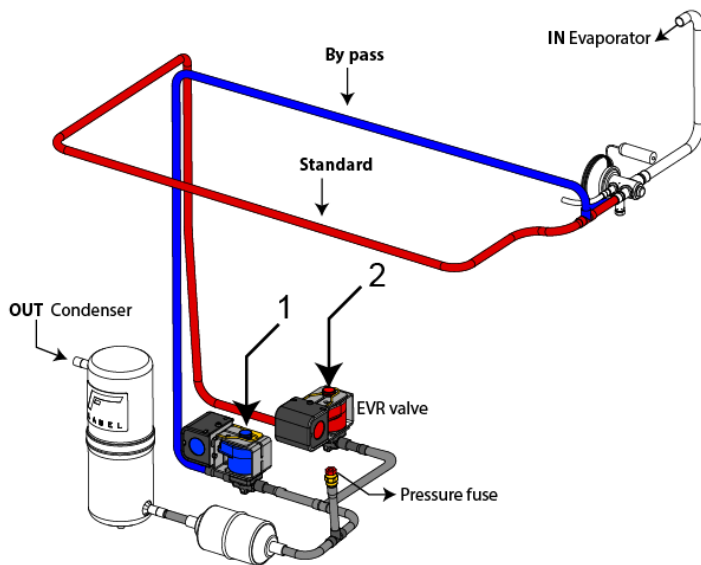

Solenoid valve (EVR) N°1 is ON only when the temperature is higher than -10°C (14F) and the other N°2 is OFF.
 Below -10°C (14F) the N°2 is ON while the N°1 is OFF.
 This is to avoid any possible over heating to the compressor due to characteristic of the gas R448a

Temperature	Valve N°1	Valve N°2
> -10°C (14F) OFF	ON	OFF
< -10°C (14F) OFF	OFF	ON



6.3.1.18 Finned Coil Condenser

1. Follow the procedure in paragraph [Electrical Box], sequence 1 and 2, to remove the condenser panel.
2. Unscrew the two screws on the inner side of both frontal feet (Fig. 1).
3. Remove the cover of the electrical box (ref. paragraph [Electrical Box]) and unscrew the two sliding support screws (Fig. 2).
4. Rest the electrical box on the finned coil condenser.
5. Follow the procedure in paragraph [Accessing the components on the back side of the appliance], to reach the condenser fans connectors and disconnect them.
6. Unscrew the three screws on the base of the condenser conveyor (Fig. 3).
7. Unscrew the clamp and release the pipe of the refrigerant circuit from the support (Fig. 4).
8. Desolder the joint upstream of the tanic receiver (Fig. 5).
9. Unscrew the two screws from the valve to release the segment of the circuit from the compressor (Fig. 6).
10. On the front side of the appliance, pull out the finned coil condenser. Pay attention to the wiring of the electrical box when pulling out the finned coil condenser, as the electrical box is released from the chassis (Fig. 7).
11. Lift slightly the electrical box to allow the releasing of the finned coil condenser, then fix again the electrical box with the two sliding support screws.
12. Follow the procedure in paragraph [Condenser fan], sequence 1, to remove the condenser fans.

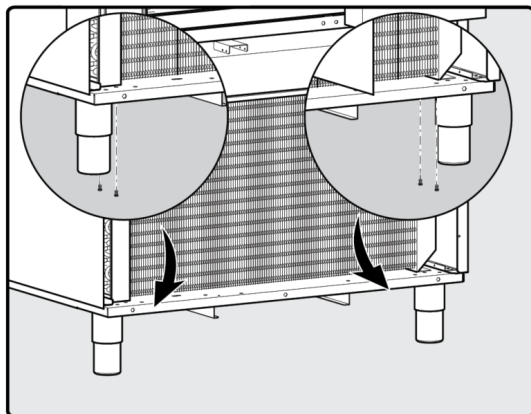

1.

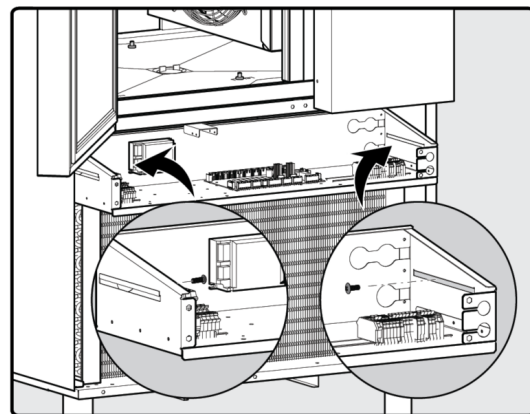

2.

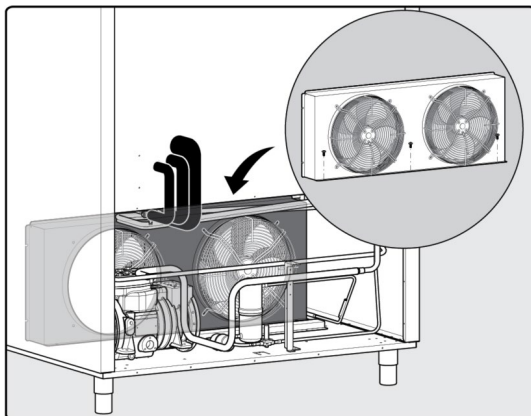

3.

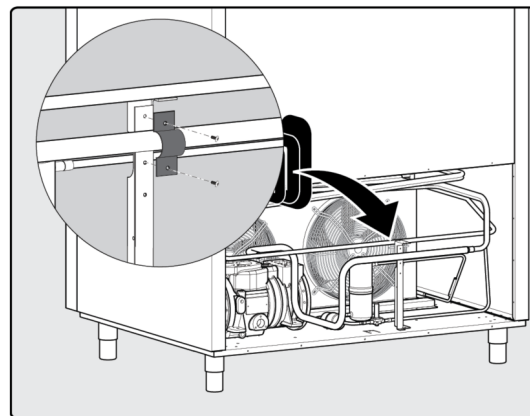

4.

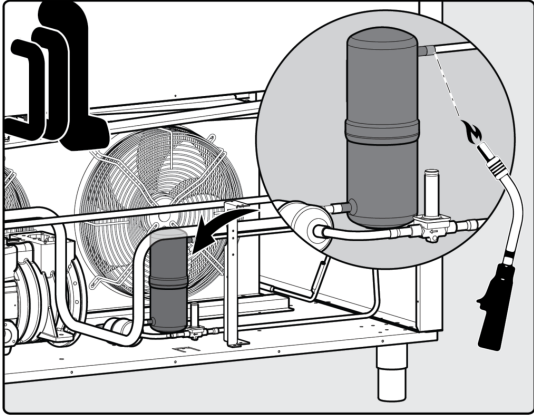
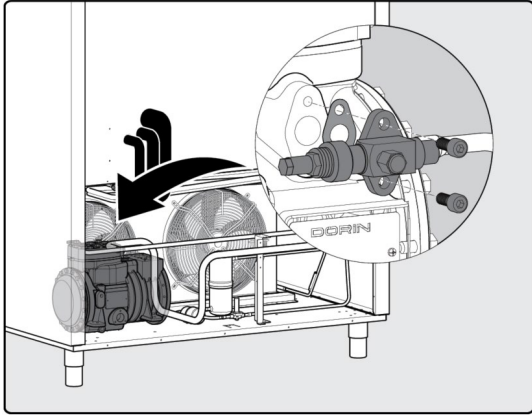
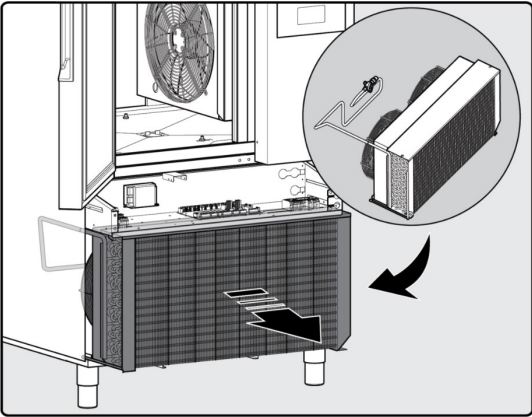

- 5. 
- 6. 
- 7. 
-



6.3.1.19 Condenser fan

1. Follow the procedure in paragraph [Accessing the components on the back side of the appliance] to reach the connector of the Condenser fan and disconnect it.
2. Unscrew the four screws of the fan grid to release the grid and the fan (Fig. 1)
3. Pull out the condenser fan with a rotation of 90° as shown in figure 2.

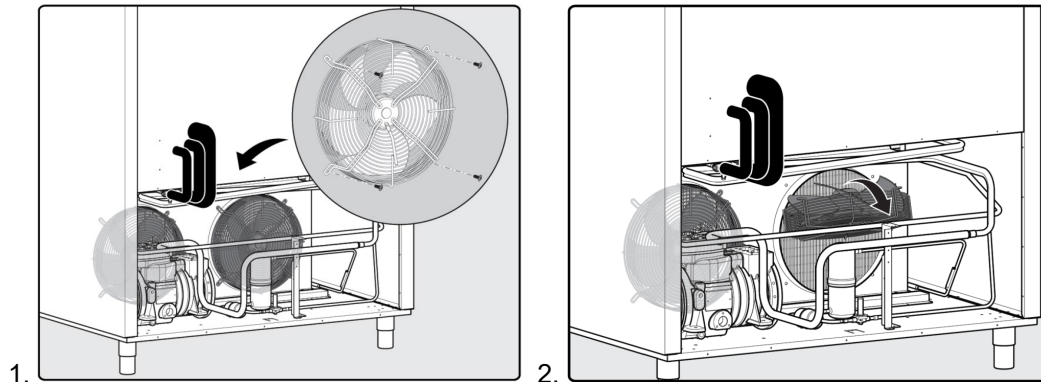

6.3.1.20 Tanic receiver

1. Follow the procedure in paragraph [Accessing the components on the back side of the appliance], sequence 1 and 2, to reach the tanic receiver.
2. Desolder the joint upstream and downstream of the tanic receiver (Fig. 1).

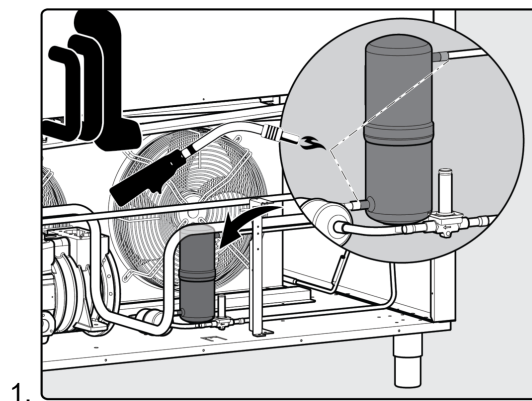

6.3.1.21 Dehidrator Filter

1. Follow the procedure in paragraph [Accessing the components on the back side of the appliance], sequence 1 and 2, to reach the Dehidrator Filter.
2. Desolder the joint upstream and downstream of the Dehidrator Filter (Fig. 1).

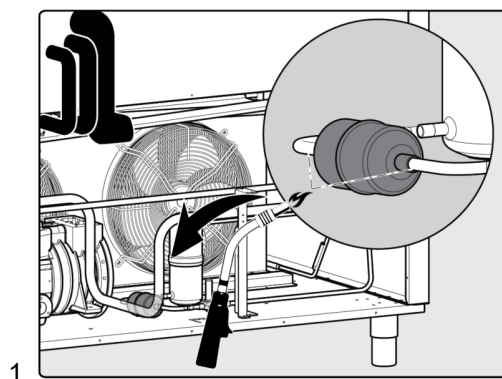



6.3.1.22 Door

1. Unscrew the four screws of the upper hinge.
2. Remove the upper hinge and the pin (Fig. 1).
3. Lift the door to remove it from the lower support.
4. Unscrew the two screws of the lower door support (Fig. 2).

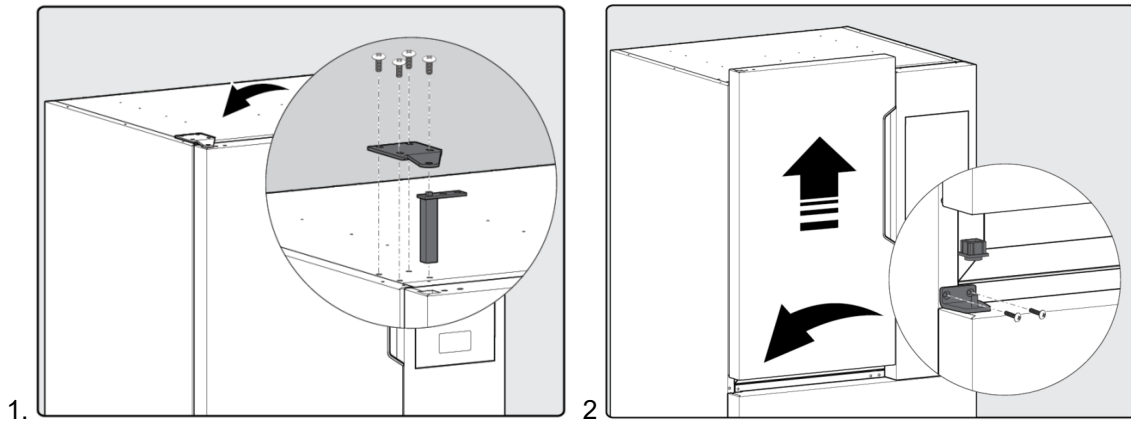

6.3.1.23 Door gasket

1. Pull out the gasket from the groove (Fig. 1)
2. Install the new one by pushing it back into the groove (see Fig. 2 for the proper insertion).

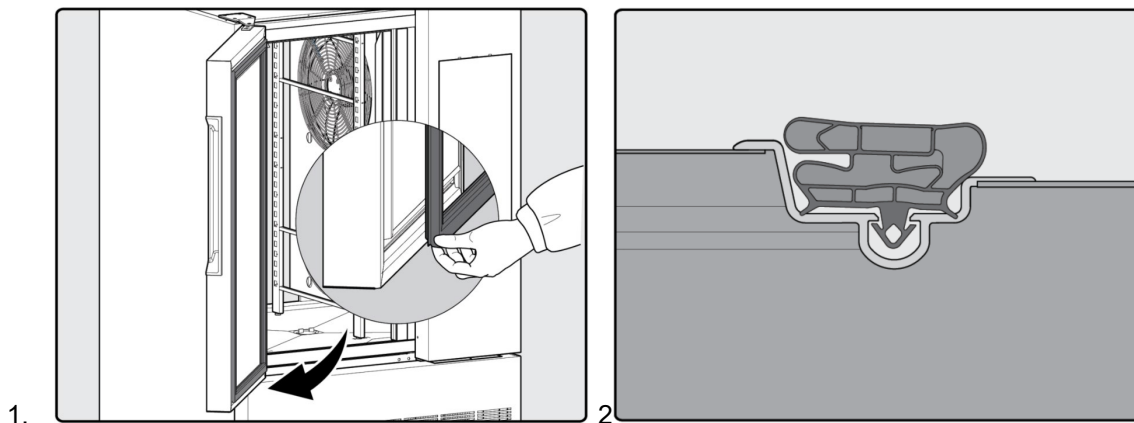

6.3.1.24 Door switch

1. Follow the procedure in paragraph [Electrical box] sequence 1 and 2 to remove the Condenser Panel.
2. Reach the door switch, unscrew the two screws and disconnect the connector (Fig. 1).

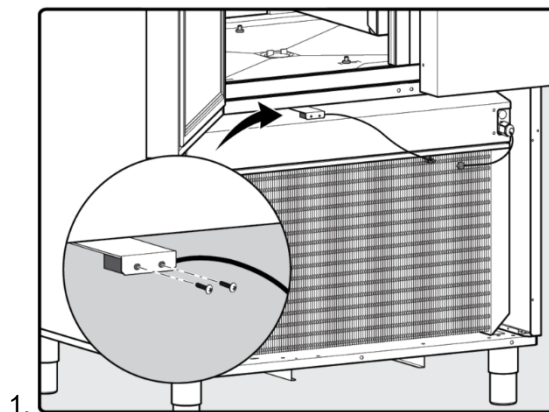



6.3.1.25 Thermostatic valve

1. Follow the procedure in paragraph [Accessing the components on the back side of the appliance],
2. Remove the insulation pipe
3. Disconnect the connectors of wiring cable
4. Remove the box protection of wiring cable,(Fig.1)
5. Disconnected the sensor of thermostatic valve and out probe, from suction pipe
6. Access to to thermostatic valve as Fig 2
7. Unwelding the thermostatic (Fig 3)
8. Wrap with a wet cloth the new thermostatic before to welding
9. Re setting the sensor and out probe evaporator in the same position of previous
10. Reassembly all part using the inverse procedure

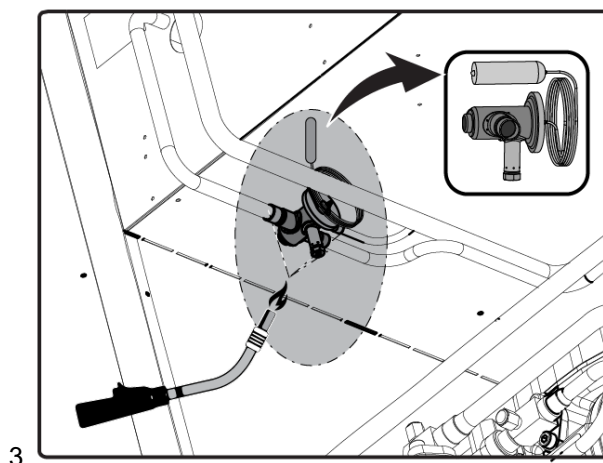
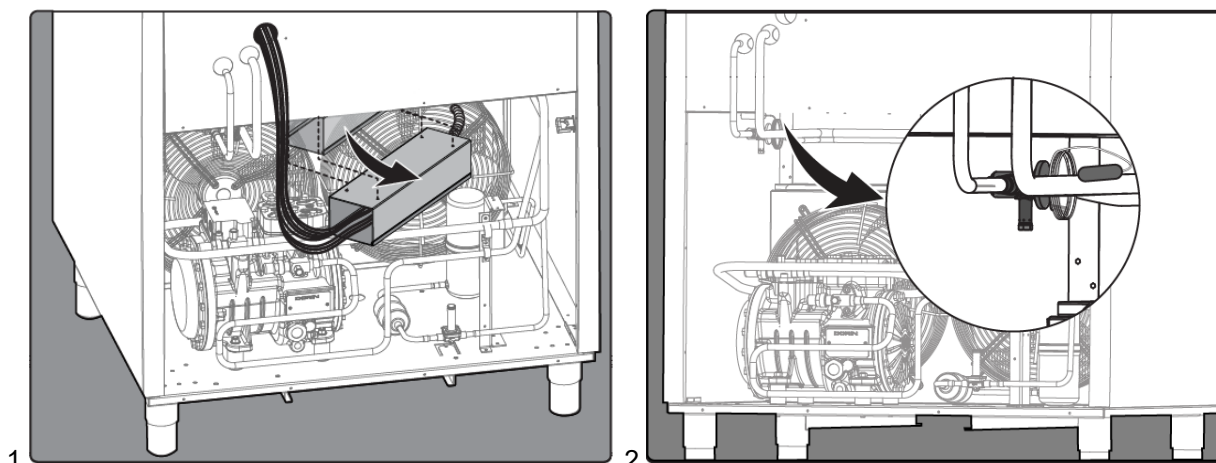



6.3.1.26 Access display and replacement of mambrane sticker



ATTENTION!

The replacement of the membrane sticker requires also the replacement of the frame, this because the glue of the membrane cannot be removed as it is a particular adesive glue/resin and once exposed to air becomes very difficult to take off and clean.

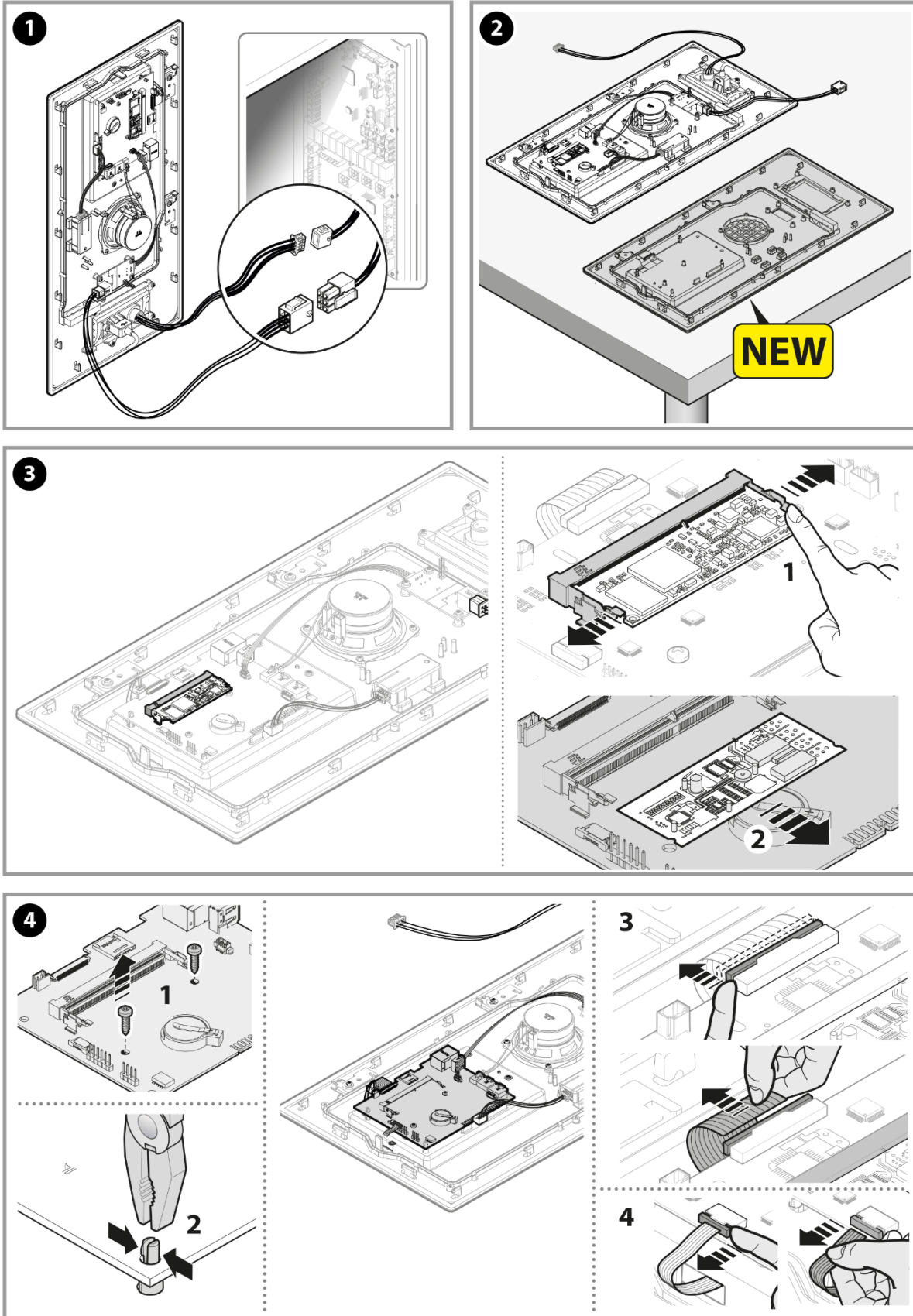

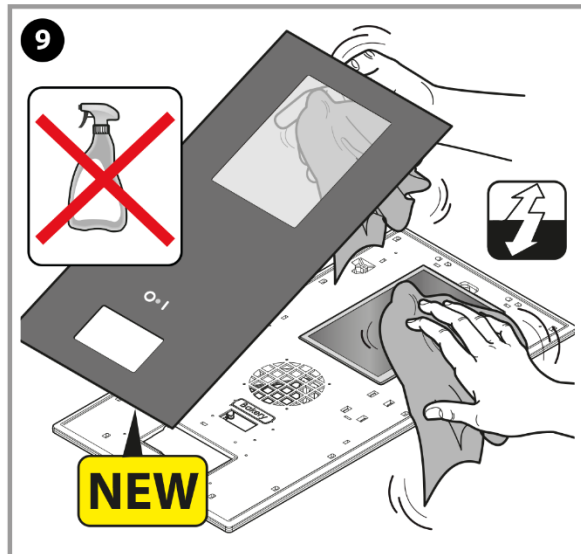
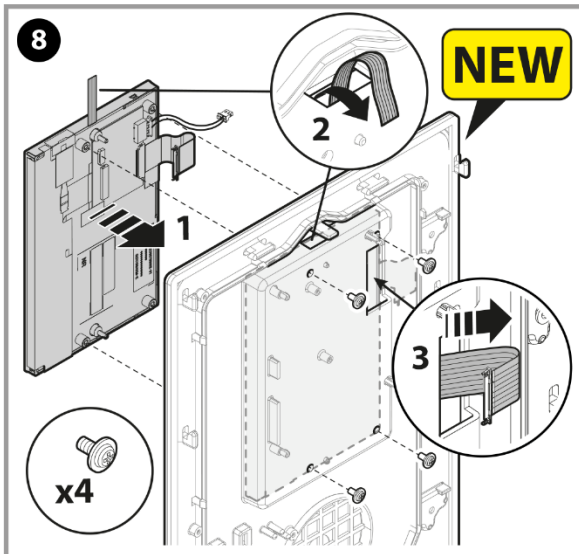
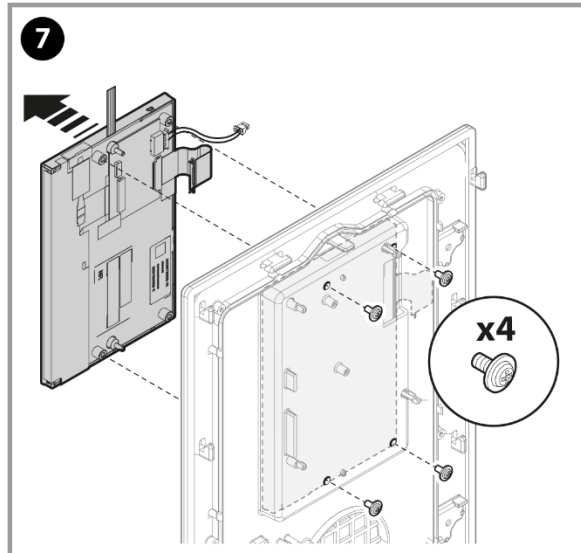
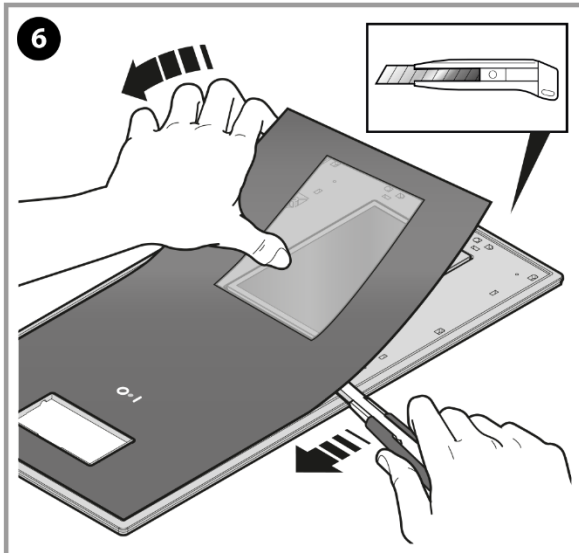
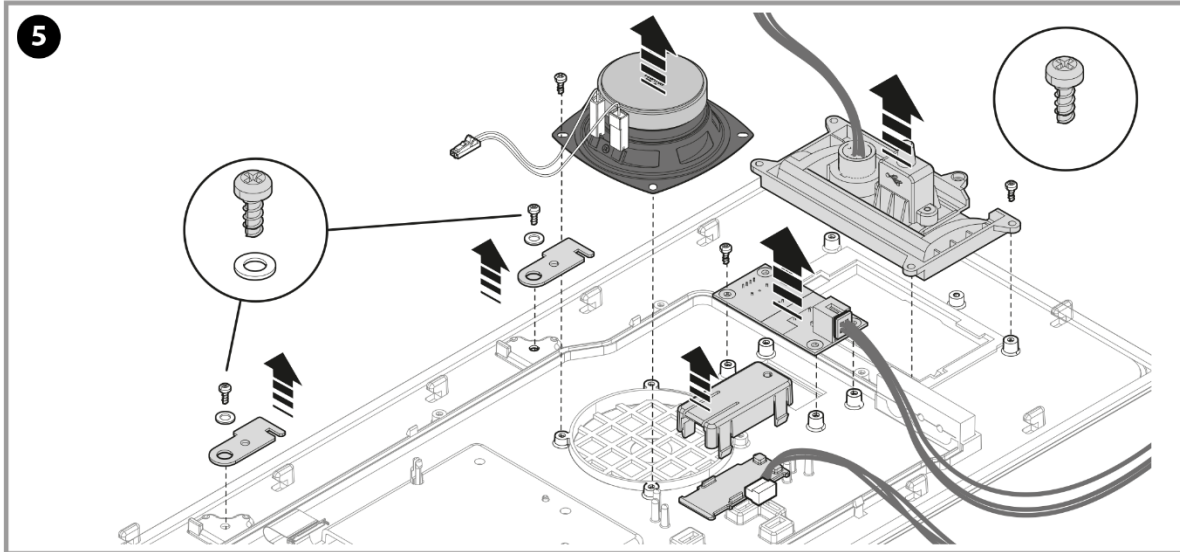

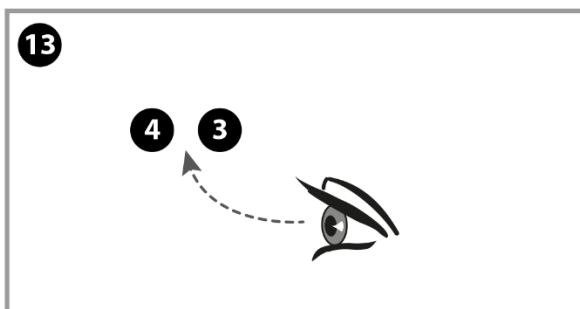
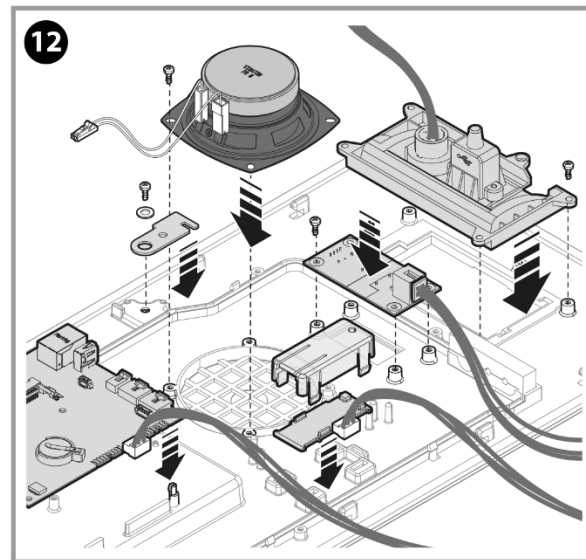
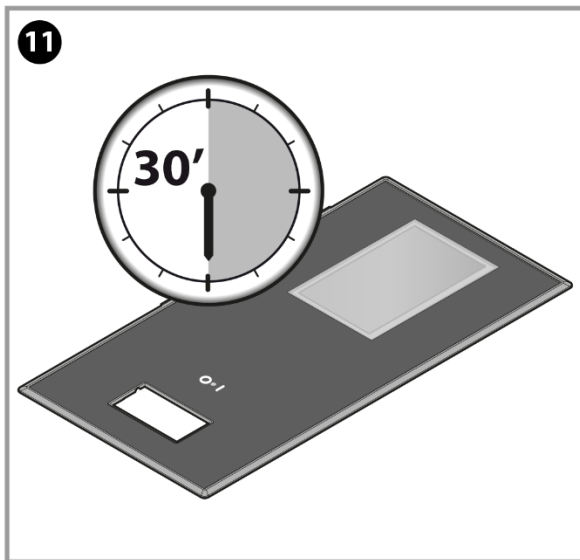
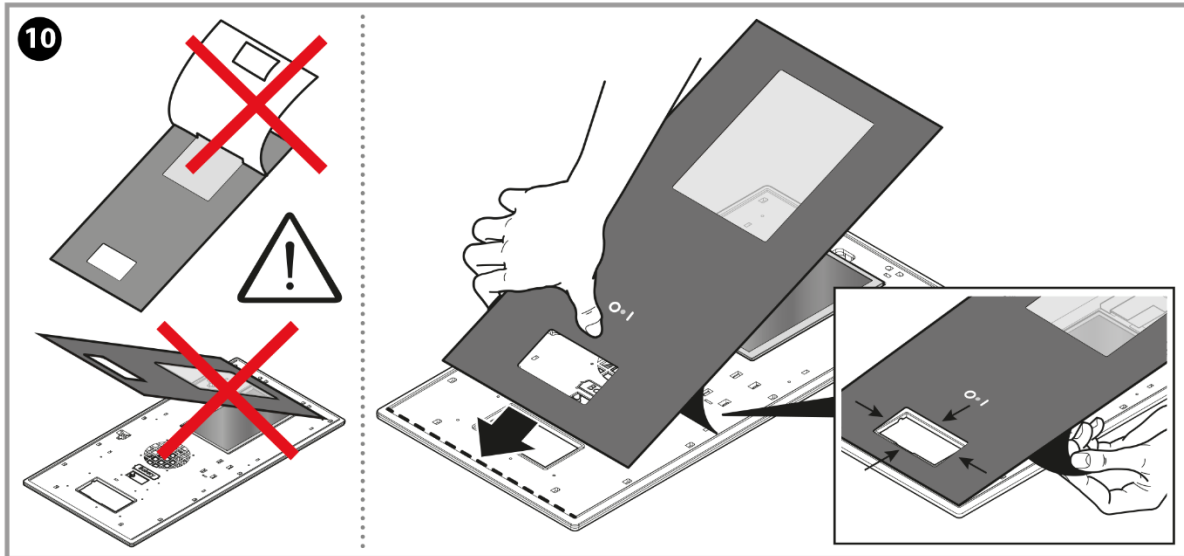

! ATTENTION!

11* = the particular adhesive glue/resin of the membrane, once exposed to air, becomes very difficult to remove. The reaction will be complete in approx. 30 minutes. In case of need to realign the new membrane time is very limited.



6.3.2 Disassembly/Reassemble Of Components Range 30 Kg

6.3.2.1 Accessing the components on the back side of the appliance

Ensure enough space around the appliance when operating on the backside.

1. Unscrew the four screw of the back spacer to remove it (Fig. 1).
2. Unscrew the ten screws of the protection grid to remove it (Fig. 2).
3. Find the wiring harness cover underneath the chamber and open it. Release the adjustable cable ties and cut the rest of the cable ties to release the wiring (Fig. 3).

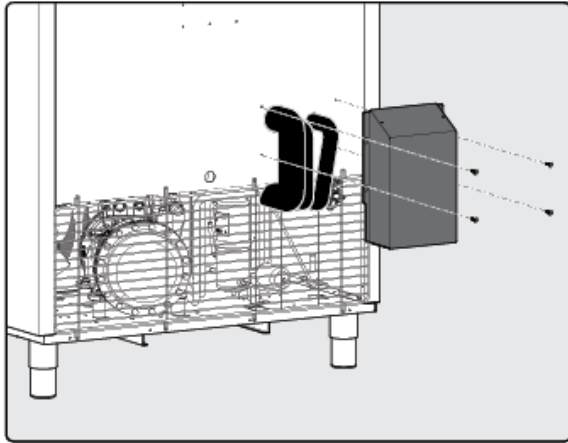

1.

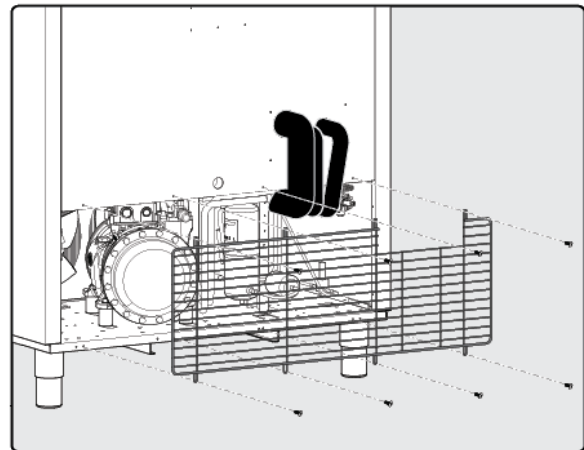

2.

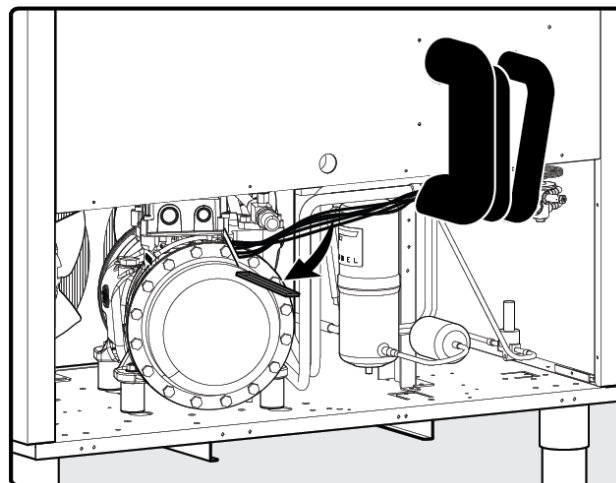

3.



6.3.2.2 Rack supports

1. Unscrew the lock nut from the front right rack support (Fig. 1).
2. Release the spring on the top of the front left rack support (Fig. 2).
3. Remove the left rack support: lift then rotate the left rack support by pulling it from the lower side (Fig. 3).
4. Move down the lock on the top of the right rack support (Fig. 4).
5. Remove the right rack support: lift then rotate the left rack support by pulling it from the lower side (Fig. 5)

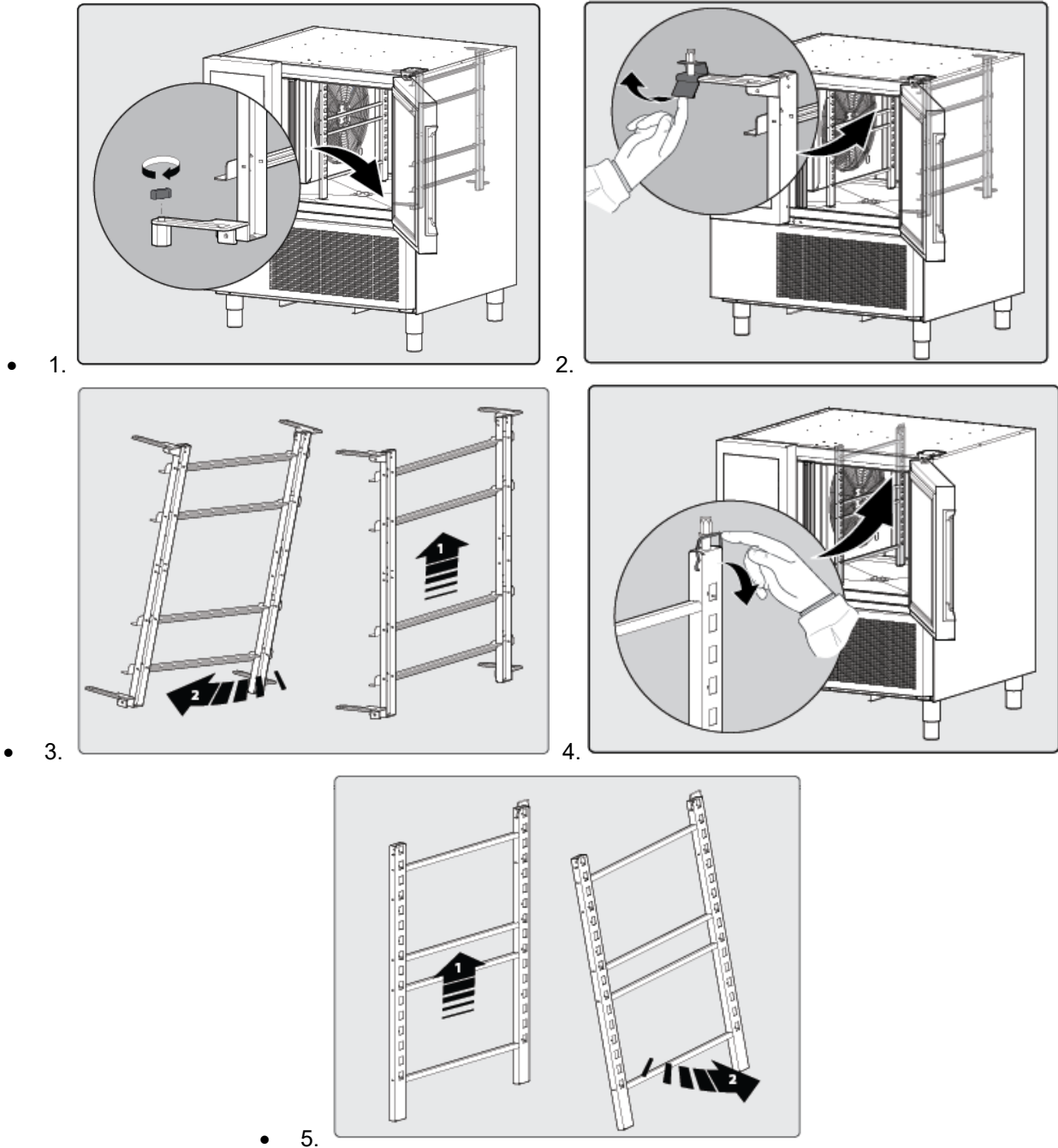



6.3.2.3 Cell probe (blue)

The cell probe is located inside the chamber, fixed on the fan protection grid.

1. Follow the procedure in paragraph [Rack support], sequence 1 and 2.
2. Remove also the pins of structure fixed on upper part of the cavity for open the carter (FIG 2)
3. Remove front deflector before open the carter.
4. Find the cell probe on the fan protection grid and cut the cable ties to release the probe (Fig. 1).
5. Open the evaporator conveyor, (If it is necessary remove also the pins of structure fixed on upper part of the cavity for open the carter) find the wire of the cell probe (Fig. 2)...
6. Pull out the sensor of the cell probe from its position.
7. Follow the procedure in paragraph [Accessing the components on the backside of the appliance] to reach the connector of the cell probe and disconnect it.
8. Using an adhesive tape, fix the end of the probe to the sensor of the new probe (Fig. 3).
9. On the side of the cell, pull out completely cable of the old cell probe up to appear the sensor of the new cell probe (Fig. 4).
10. Fix the sensor of the new cell probe in the same position on the fan protection grid.
11. Use cable ties to restore the wiring layout.
12. Reassemble all the removed components following the inverse procedure.

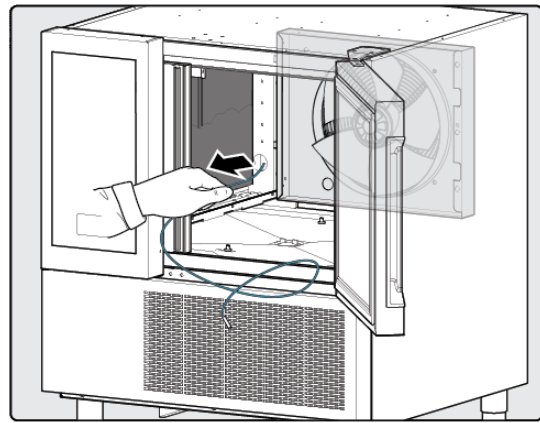
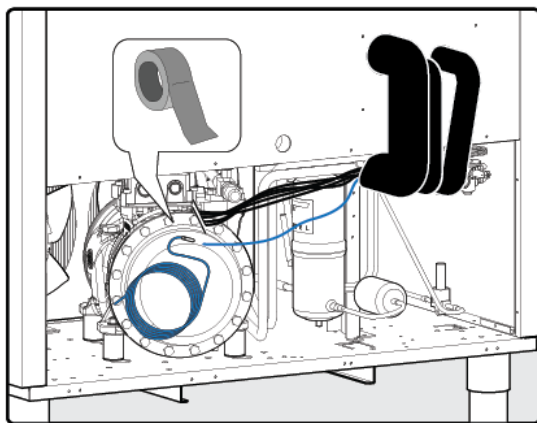
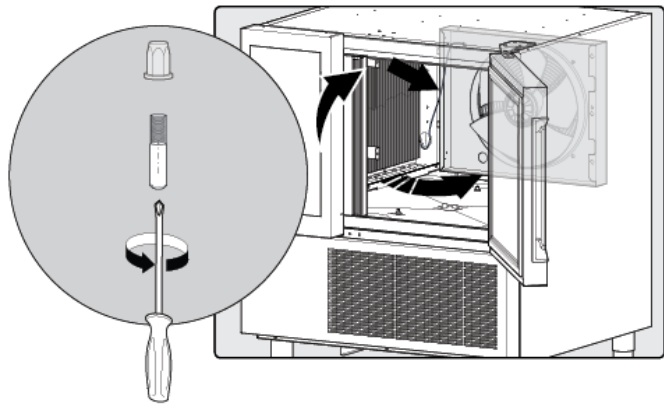
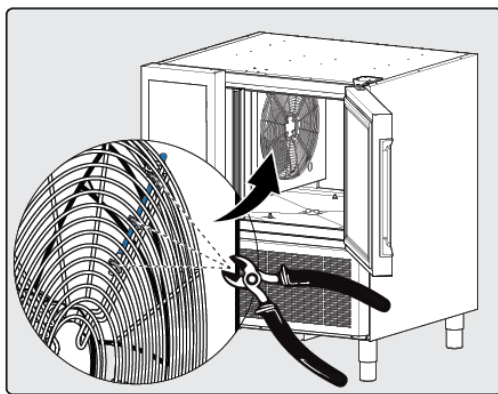



6.3.2.4 Evaporator probe (grey)

1. Follow the procedure in paragraph [rack support point 1 to 2].
2. Open the evaporator conveyor as showed in the paragraph [cell probe point 2 three], find the evaporator probe and pull out carefully the sensor from its position (Fig. 1).
3. Follow the procedure in paragraph [Accessing the components on the backside of the appliance] to reach the connector of the evaporator probe and disconnect it.
4. Using an adhesive tape, fix the end of the probe to the sensor of the new probe (Fig. 2).
5. On the side of the cell, pull out completely cable of the old cell probe up to appear the sensor of the new cell probe (Fig. 3).
6. Insert the sensor of the new evap. probe in the same position on the evaporator (approx. 50 mm distance from the upper edge and right edge).
7. Use cable ties to restore the wiring layout.
8. Reassemble all the removed components following the inverse procedure.

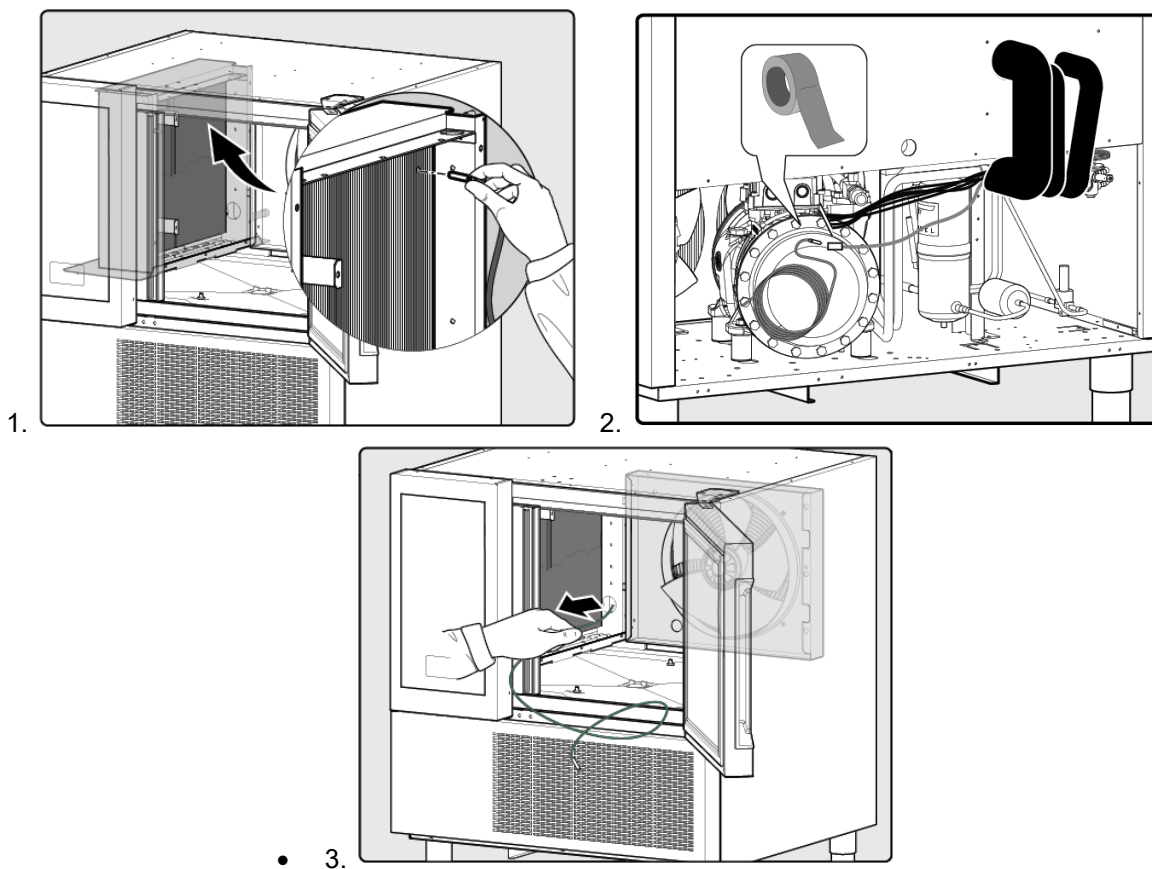



6.3.2.5 Food probe

1. Follow the procedure in paragraph [rack support point 1 to 2 and cell probe point 2 .3].
2. Open the evaporator conveyor and unscrew the two screws shown in (Fig. 1) for remove the wiring cover.
3. Unsnap the rubber fairlead to ease the passage of the probe connector.
4. Follow the procedure in paragraph [Accessing the components on the backside of the appliance] to reach the connector of the food probe to be replaced and disconnect it.
5. Fix the connector of the food probe to be replaced to a fairlead probe using an adhesive tape (Fig. 2).
6. On the cell side, pull out completely the wiring of the food probe up to appear the fairlead probe (Fig. 3).
7. Fix the connector of the new food probe to the fairlead probe using an adhesive tape (Fig. 4).
8. On the rear side of the appliance, pull out completely the fairlead probe up to the appear the connector of the food probe (Fig. 5).
9. Connect the new food probe to the same connector of the replaced food probe.
10. Use cable ties to restore the wiring layout.
11. Reassemble all the removed components following the inverse procedure.

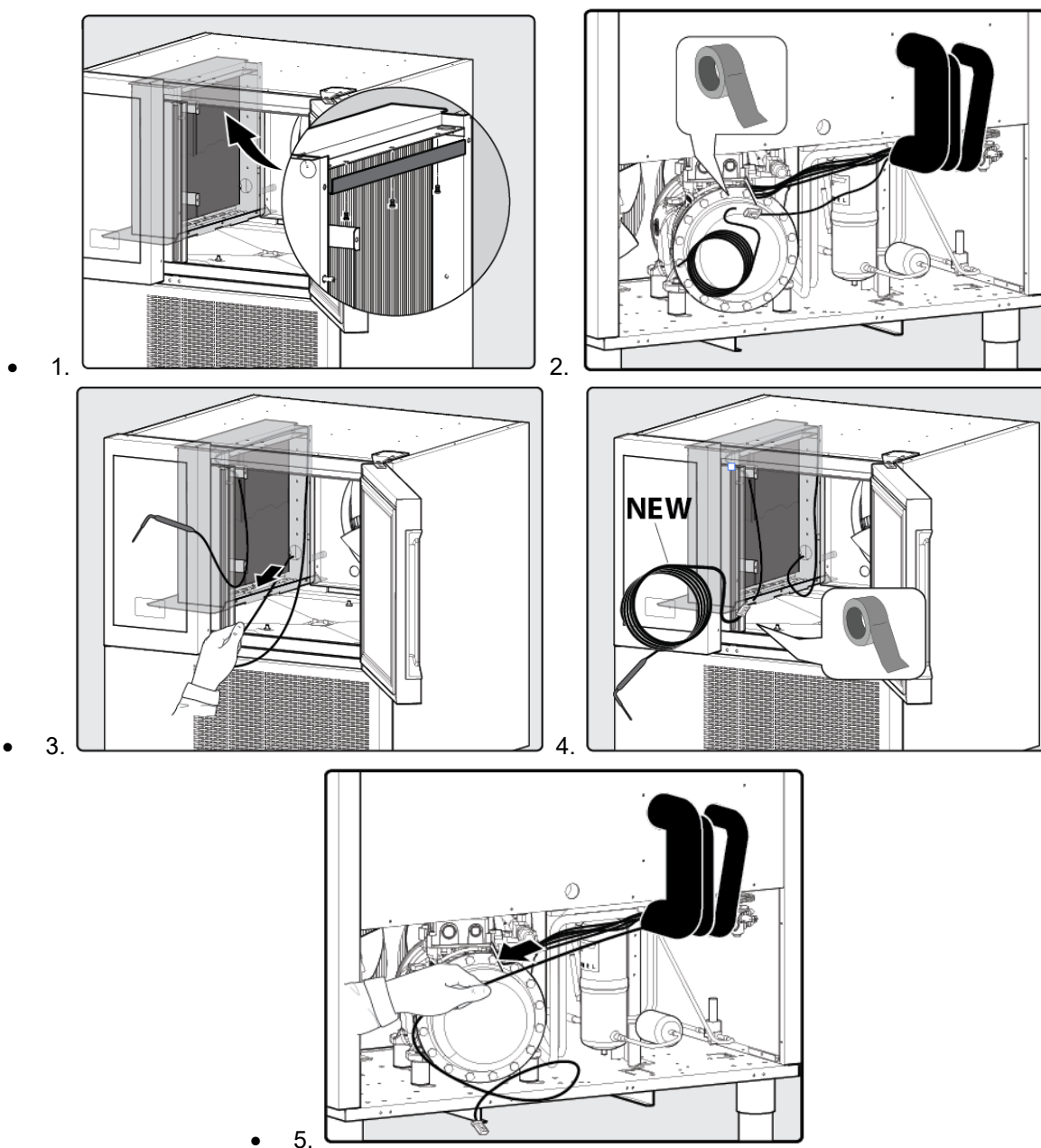



6.3.2.6 Condenser probe (black)

1. Follow the procedure in paragraph [Accessing the components on the backside of the appliance] to reach the connector of the condenser probe and disconnect it.
2. Pull out the condenser probe from its position (Fig. 1).
3. Insert the sensor of the new condenser probe into the seat.
4. Use cable ties to restore the wiring layout.
5. Reassemble all the removed components following the inverse procedure.

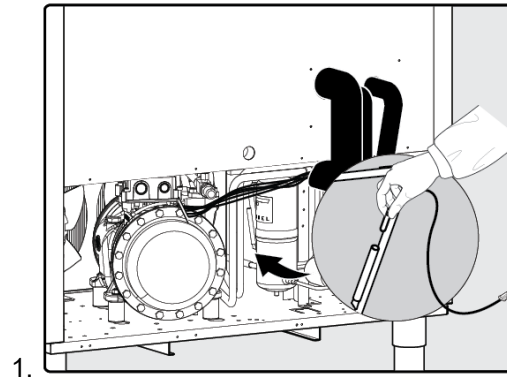

6.3.2.7 Out evaporator probe (green)

1. Follow the procedure in paragraph [Accessing the components on the backside of the appliance] to reach the connector of the suction probe and disconnect it.
2. Cut the insulation near the expansion valve to reach the suction probe.
3. Unscrew the clamp of expansion valve sensor to release the suction probe sensor, and then pull out the suction probe sensor (Fig. 1).
4. Insert the sensor of the new suction probe into the seat (Fig. 2), and then tighten the screw of the clamp. Do not overtighten the screw in order to prevent any damage to the sensors.
5. Restore the insulation accurately. Use a cable tie to fix the insulation and the suction probe (Fig. 3).
6. Use cable ties to restore the wiring layout.
7. Reassemble all the removed components following the inverse procedure.

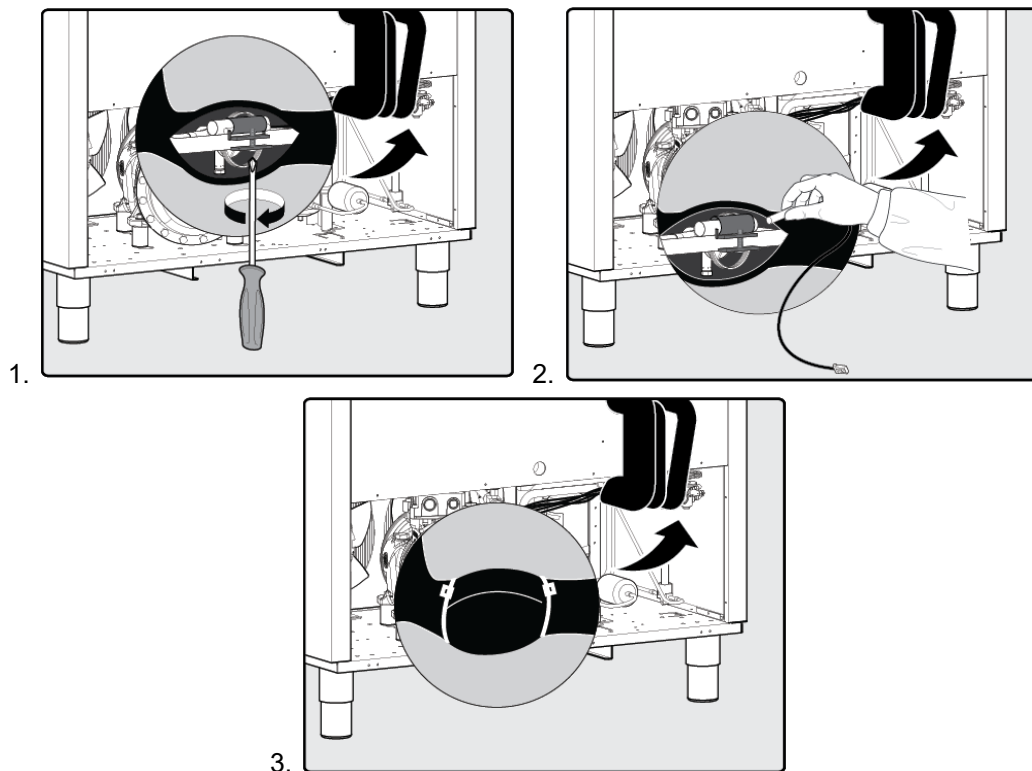



6.3.2.8 Thermostat

1. Follow the procedure in paragraph [*rack support point 4 to 5 and cell probe point 2 3*].
2. Open the evaporator conveyor and unscrew the nut shown in figure 1 to release the thermostats.
3. Release the adjustable cable ties and cut the rest of the cable ties to release the wiring.
4. Disconnect the connector of the thermostat and replace it with the new one.
5. Use cable ties to restore the wiring layout.
6. Reassemble all the removed components following the inverse procedure.

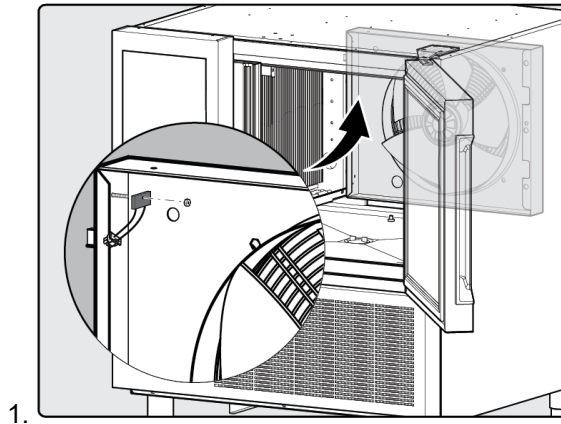

6.3.2.9 Evaporator fan

1. Follow the procedure in paragraph [*rack support 1 to 2*]
2. Follow the procedure in paragraph [*cell probe 2 to 3*]
3. Unscrew the two screws of the carter evaporator.
4. The front deflector will be disassembled before open the carter as well (Fig. 1).
5. Open the evaporator conveyor, release the adjustable cable ties and cut the rest of the cable ties to release the wiring.
6. Follow the procedure in paragraph [*Accessing the components on the backside of the appliance*] to reach the connectors of the evaporator fans to be replaced and disconnect them.
7. Fix the one connector of the evaporator fan to be replaced to a fairlead probe using an adhesive tape (Fig. 2).
8. On the cell side, pull out completely the wiring of the evaporator fan up to appear the fairlead probe (Fig. 3).
9. Unscrew the four screws of the fan grid to release the grid and the fan (Fig. 4).
10. Install the new evaporator fan following the inverse procedure. Make sure to pass the wiring of the new fan through the fairlead on the evaporator conveyor.
11. Fix the wiring to the fairlead probe using an adhesive tape (Fig. 5).
12. On the rear side of the appliance, pull out completely the fairlead probe up to the appear the connectors of the evaporator fan (Fig. 6).
13. Connect the wiring of the new fan to the same connectors of the replaced fan.
14. Use cable ties to restore the wiring layout.
15. Reassemble all the removed components following the inverse procedure.

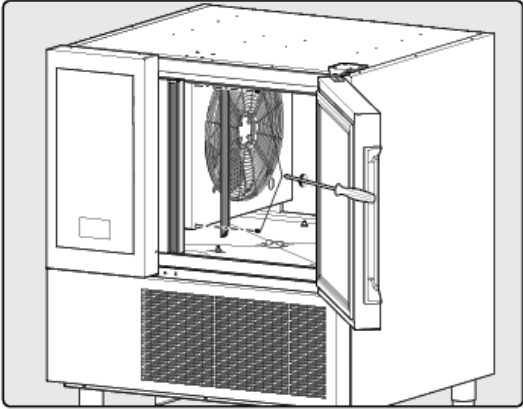
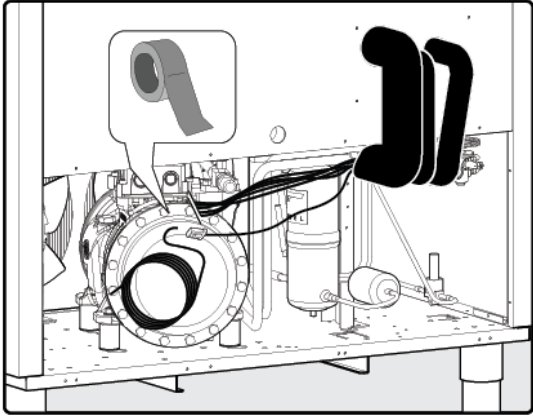
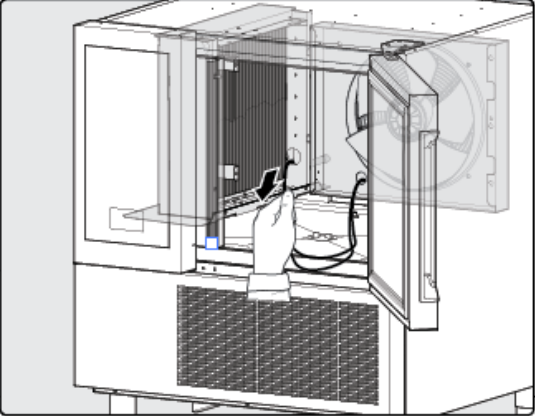
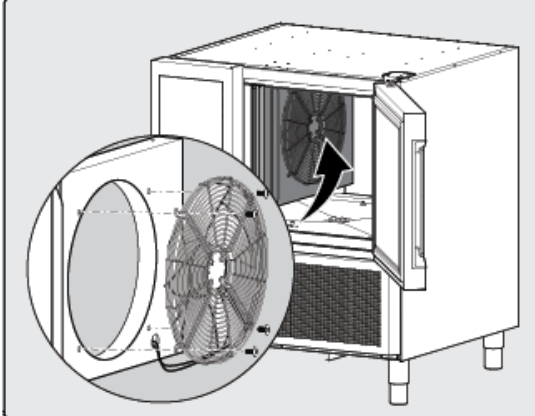
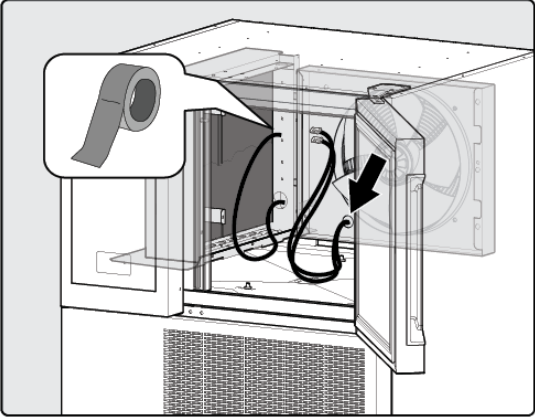
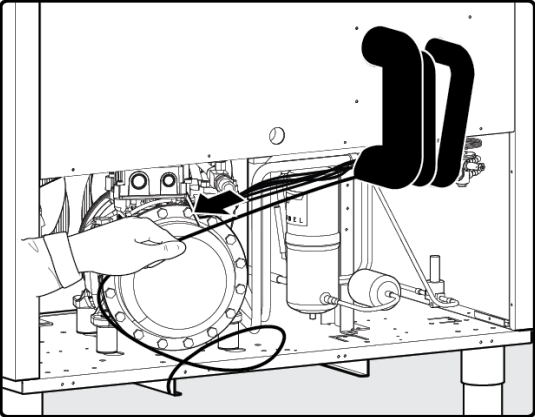

- 1.  2. 
- 3.  4. 
- 5.  6. 



6.3.2.10 Heating element

1. Follow the procedure in paragraph [rack support 1.2 and cell probe 2 to 3], sequence
2. Disconnect the connector from clixson to heating element.
3. Follow the procedure in paragraph [Accessing the components on the backside of the appliance] to reach the connectors of the heating element to be replaced and disconnect them.
4. Unscrew the screw of the bracket to release the heating element.
5. Remove the heating element first moving it forward into the slot, then pull the heating element out with a slight rotation (Fig. 1).
6. Fix the connector of the heating element to be replaced to a wiring guide using an adhesive tape
7. On the cell side, pull out completely the wiring guide up to appear the fairlead pipe
8. Install the new heating element following the inverse procedure.
9. Use cable ties to restore the wiring layout.
10. Reassemble all the removed components following the inverse procedure.

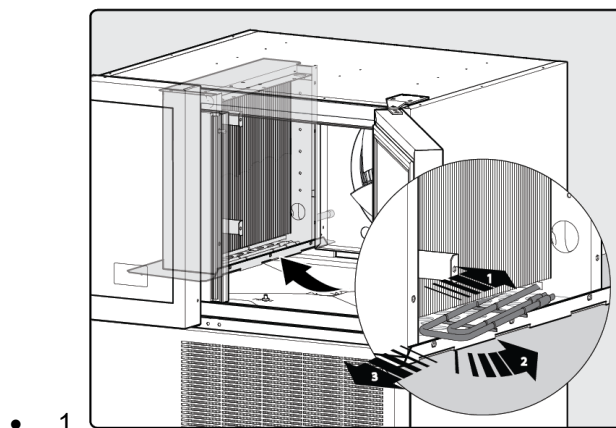

• 1.

6.3.2.11 Command Panel

1. Open the flap of the USB port and unscrew the screw shown in figure 1.
2. Push down and pull out the Command Panel carefully to prevent any damage to the wiring.
3. Use the two hooks on the left side of the Command Panel to hang it on the Control Panel (Fig. 2).
4. Unsnap the protection command panel to access the electronic components.
5. Disconnect all the connectors to release the Command Panel.
6.  **WARNING:** the back protection on command panel it is fixed with some hook and screws. To avoid the bended the control panel when the back protection come reassembled attention to tithing too much the screws

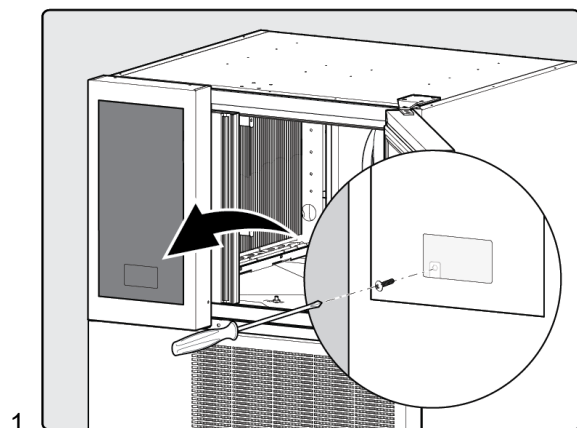

1.

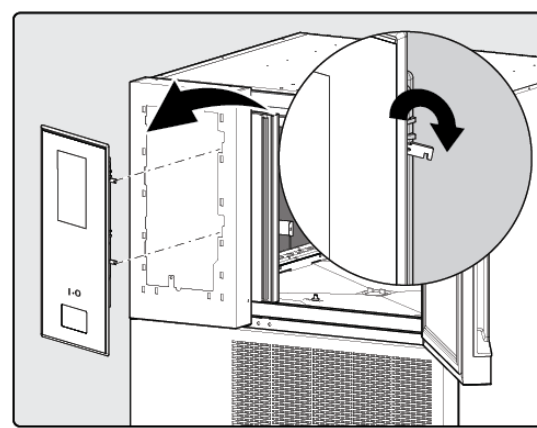

2.



6.3.2.12 Control Panel

1. Follow the procedure in paragraph [Command Panel], to remove the Command Panel.
2. Unscrew the four screws shown in figure 1 to disassemble the control panel (2 screws on top, one on left side, one on right side).
3. Unscrew the nut shown in figure 2 to release the grounding connection.

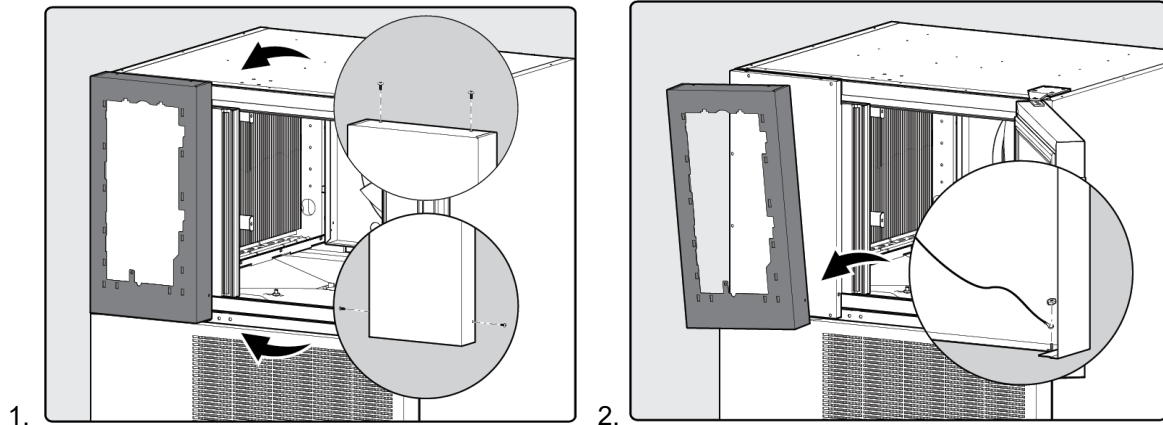

6.3.2.13 Frame heating element cable

1. Follow the procedure in paragraph [Command Panel] to remove the Command Panel.
2. Follow the procedure in paragraph [Control Panel] to remove the Control Panel.
3. Follow the procedure in paragraph [Electrical box] sequence 1 and 2 to remove the Condenser Panel.
4. Reach the connector of the heating element cable and disconnect it (Fig. 1).
5. Remove the magnetic cover: use a flat screwdriver to make lever on the upper part of the frame and unsnap a segment, then remove it completely by hand (Fig. 2).
6. Pull out the vertical segment of the heating element cable (Fig. 3).
7. Unscrew the six screws shown in figure 4 to disassemble the evaporator-foamed panel.
8. Remove the rest of the magnetic covers (Fig. 5).
9. Pull out completely the heating element cable.
10. Install the new heating element cable following the inverse procedure. Refer to figure 6 for the correct layout of the heating element cable.
11. Reassemble all the removed components following the inverse procedure.

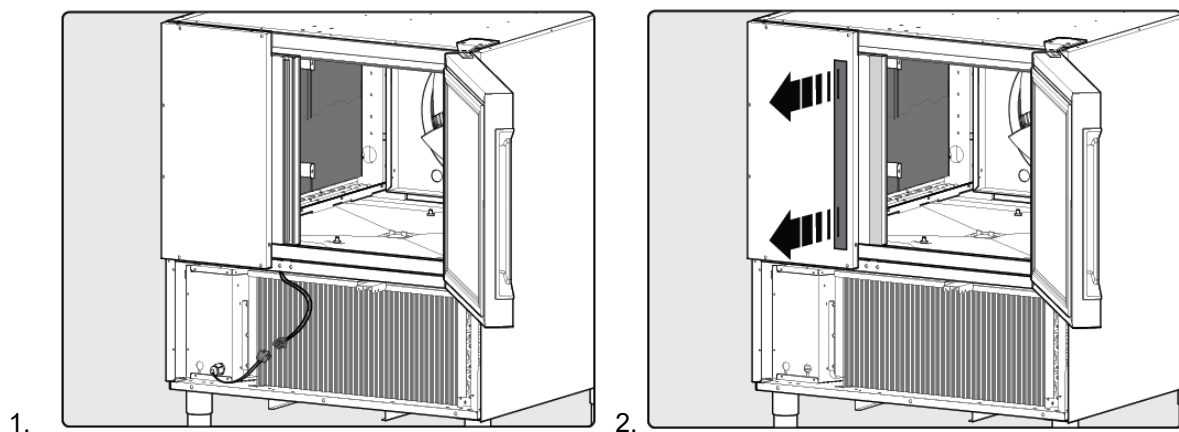

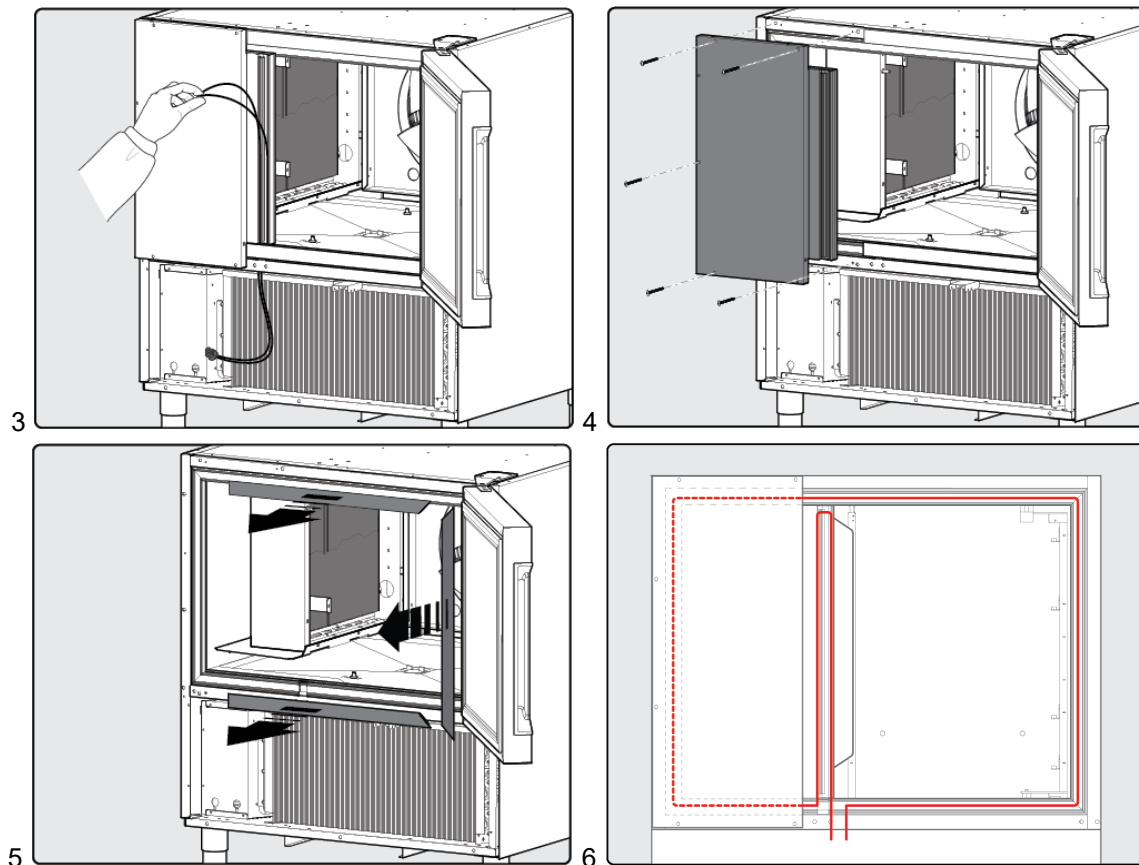

6.3.2.14 Evaporator

1. Follow the procedure in paragraph [*rack support 1 to 2 and cell probe 2 to 3*], sequence
2. Lift the evaporator conveyor to remove it from the hinges and rest it carefully inside the cell (Fig.1).
3. Follow the procedure in paragraph [*Heating element cable*], sequence 1 to 4, to remove the control panel and the evaporator-foamed panel.
4. Remove the evaporator probe from evaporator.
5. Follow the procedure in paragraph [*Heating element*] to remove the heating element from the evaporator.
6. Follow the procedure in paragraph [*Accessing the components on the backside of the appliance*] to reach the connectors of the wiring of all the components inside the cell (food probes, cell, probe, evaporator probe, thermostats, fans) and disconnect them.
7. Fix the end of one cable to a fairlead probe using an adhesive tape (Fig. 2).
8. On the cell side, pull out completely the wiring up to appear the fairlead probe (Fig. 3).
9. Remove the food probes from the evaporator.
10. On the rear side of the appliance, remove the insulation from the two pipes of the refrigerant circuit connected to the evaporator, then unwelding the joints between the evaporator and the circuit (Fig. 4).
11.  **WARNING:** THE CIRCUIT MUST BE EMPTY BEFORE USE A FLAME!
12. Unscrew the two screws shown in figure 5 to release the evaporator. Use a spacer underneath the evaporator to prevent it from dropping.
13. Pull out the evaporator with a slight rotation (Fig. 6).
14. Install the new evaporator following the inverse procedure.
15. Make sure that the fairlead probe passes through the proper fairlead on the evaporator then fix the wiring of all the components inside the cell to the fairlead probe using an adhesive tape (Fig. 7).
16. On the rear side of the appliance, pull out completely the fairlead probe up to the appear all the connectors of the wiring (Fig. 8).
17. Connect the wiring of the proper connectors.
18. Use cable ties to restore the wiring layout.



19. Restore the joint between the evaporator and the refrigerant circuit.
20. Restore the insulation of the pipes accurately.
21. Reassemble all the removed components following the inverse procedure.

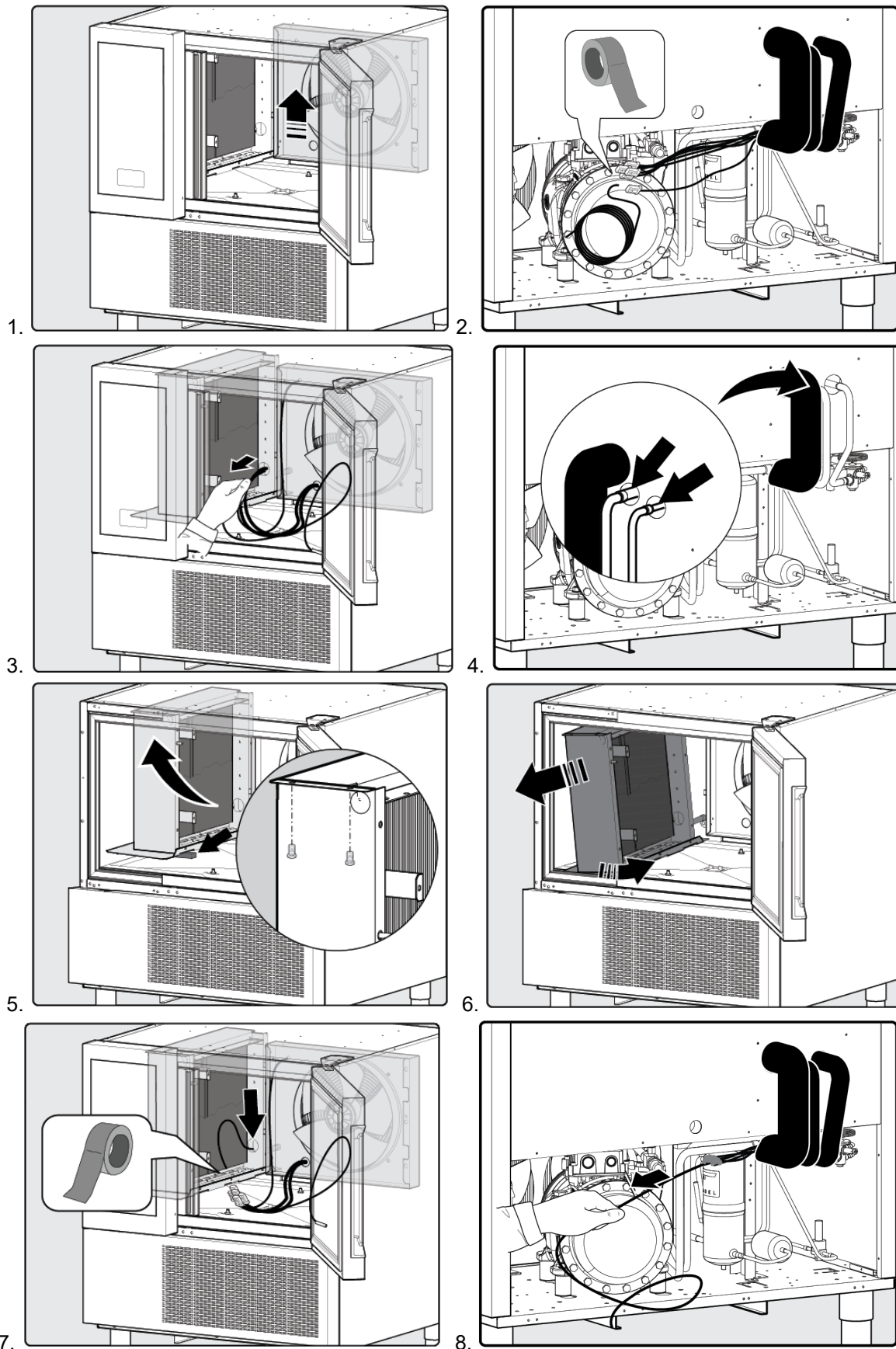



6.3.2.15 Electrical box

1. Unscrew the three screws on the lower side of the condenser panel (Fig. 1).
2. Remove the condenser panel: slide it slightly to right then pull (Fig. 2).
3. Slide out the electrical box by pulling it (Fig. 3).

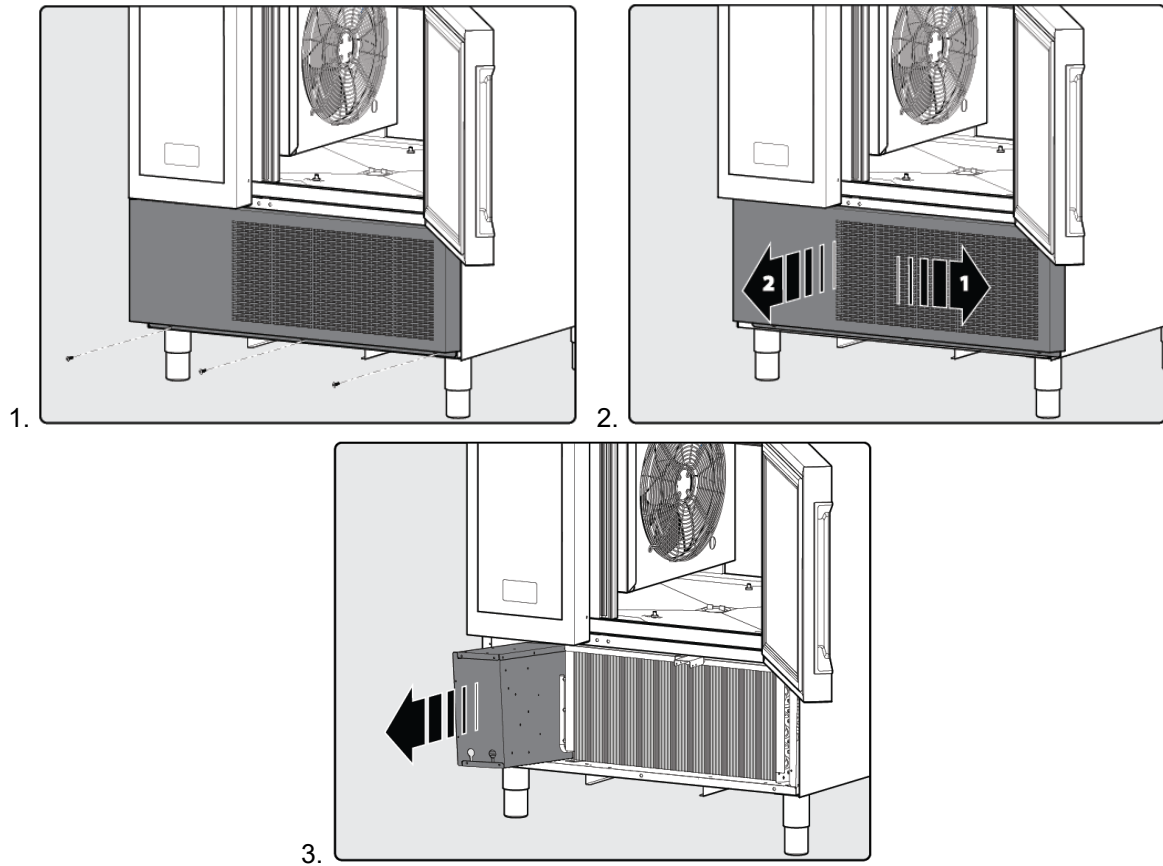



6.3.2.16 Compressor

1. Follow the procedure in paragraph [Accessing the components on the backside of the appliance] to reach the compressor.
2. Close the low pressure supply by screwing clockwise the valve, (use Info on chapter ROTALOCK VALVES)
- i** **Information:** if it is present refrigerant inside of circuit use the same procedure point 2 with the unit in ON, and then wait for 10 minutes (Fig. 1).
3. Close the high-pressure supply by screwing clockwise the valve. (use Info on chapter ROTALOCK VALVES)
4. Switch OFF the unit if used the procedure write in the **i** point.
5. Connect the vacuum pump and create vacuum in the compressor.
6. Shut down the power supply to the appliance.
7. Disconnect the wiring to the compressor.
8. Unscrew the two screws from each valve (low and high pressure) to release the compressor from the circuit (Fig. 2).
9. Unscrew the clamp and release the pipe of the refrigerant circuit from the support (Fig. 3).
10. Unscrew the four nuts at the basement of the compressor to release it from the chassis (Fig. 4).
11. Pull out the compressor from basement
12. Remove the electrical box protection of compressor to disconnect the wiring power connections (Fig. 5).

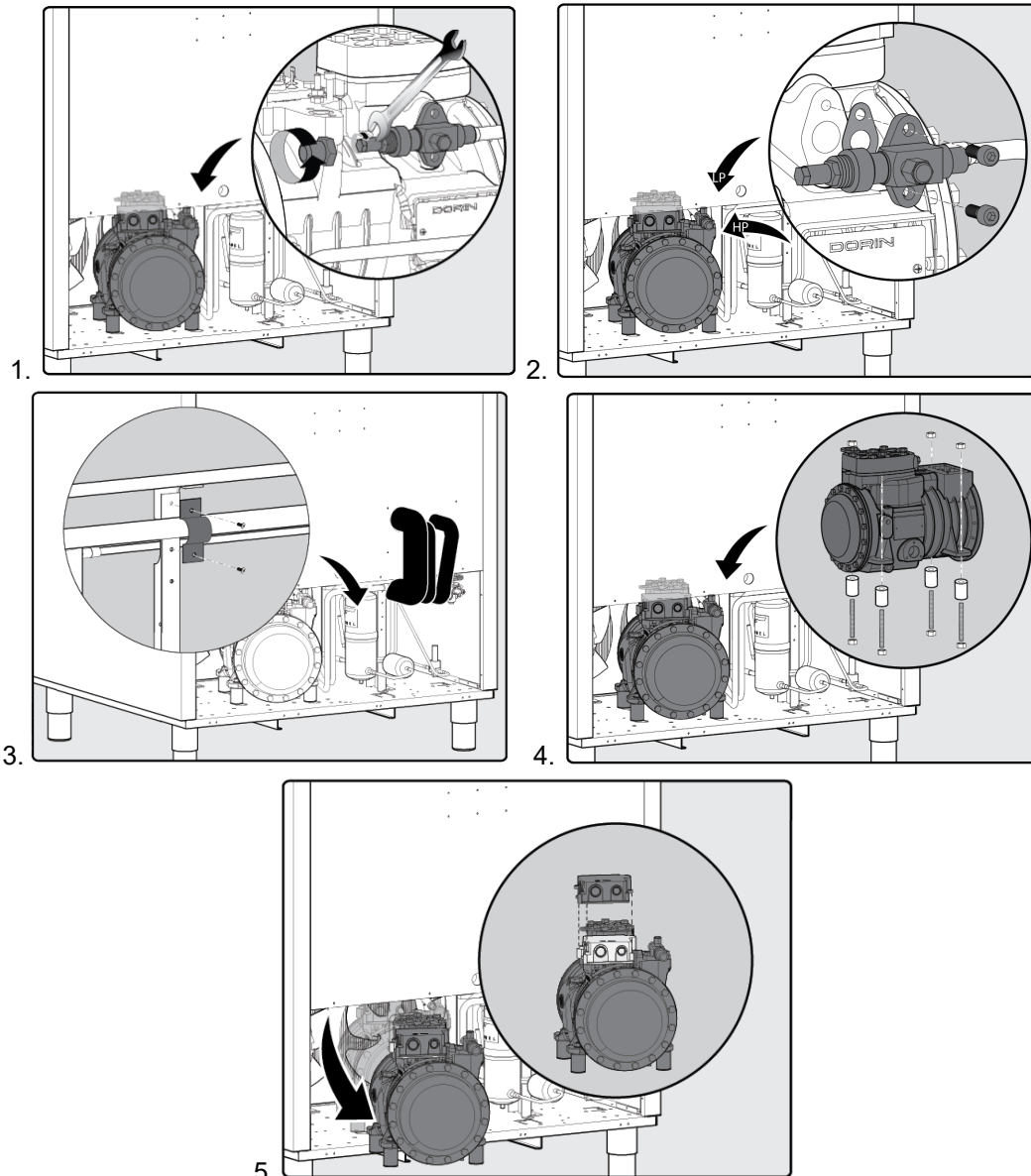



6.3.2.17 Solenoid valve

1. Follow the procedure in paragraph [Accessing the components on the backside of the appliance] to reach the solenoid valve.
2. Remove the screw of the power connector on the coil of solenoid valve (Fig. 1).
3. Remove the spring retaining coil and remove the coil upwards from body valve (Fig. 2).
4. Unwelding the joints upstream and downstream of the valve.

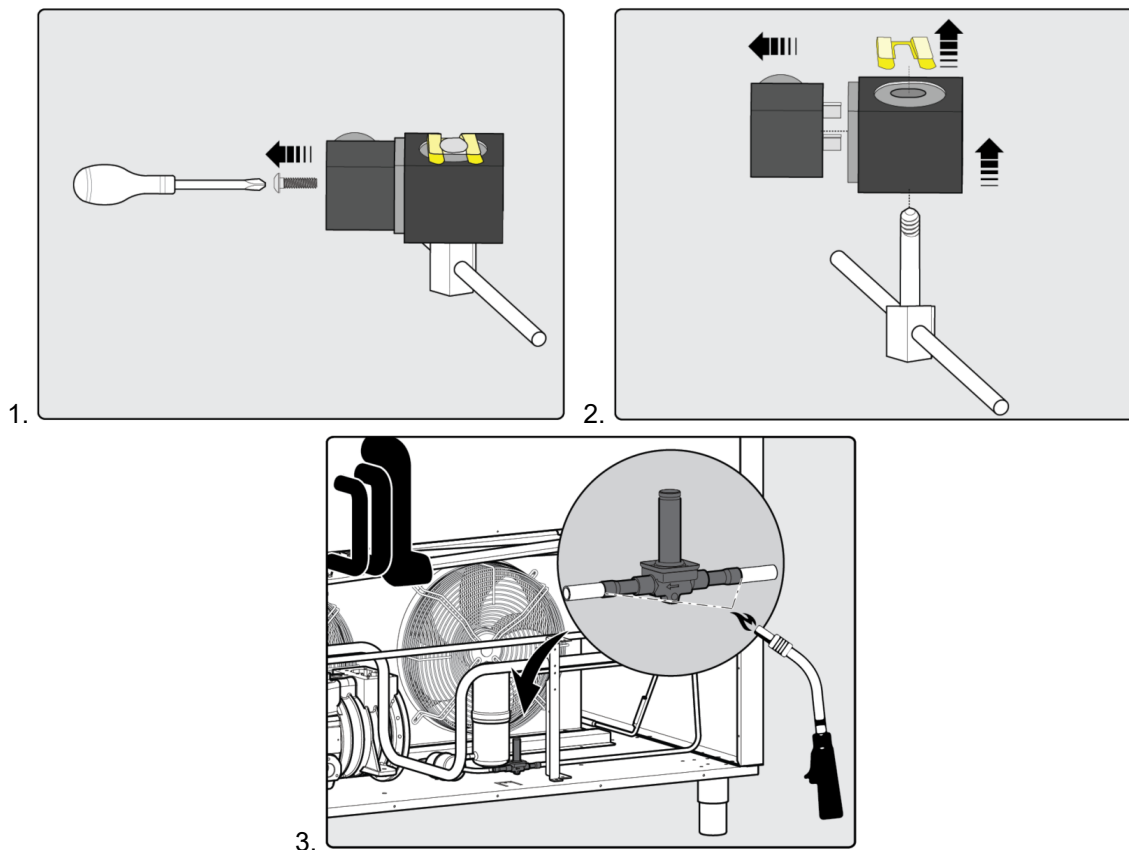

i Information: in the USA model only, there are two solenoid valves due to the gas pressure used (R448a) These valves are installed one a normal circuit (n°2) and the other used as by pass (n°1) always in the HP circuit.

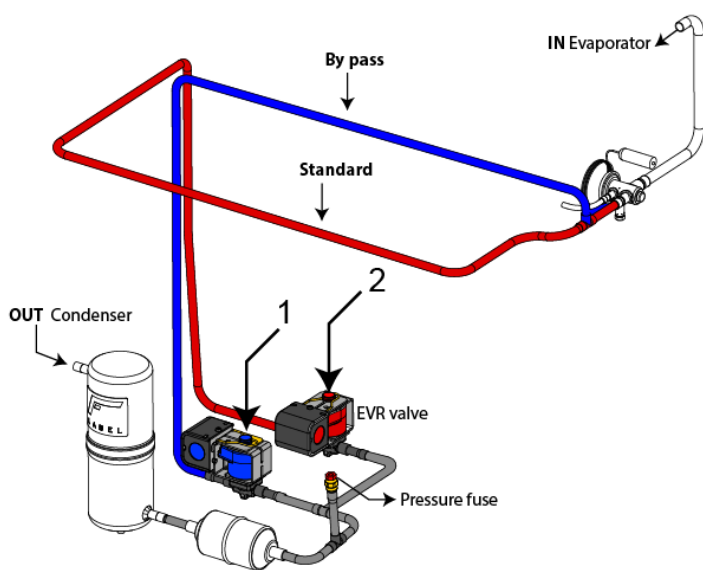

Solenoid valve (EVR) N°1 is ON only when the temperature is higher than -10°C (14F) and the other N°2 is OFF. Below -10°C (14F) the N°2 is ON while the N°1 is OFF. This is to avoid any possible over heating to the compressor due to characteristic of the gas R448a

Temperature	Valve N°1	Valve N°2
> -10°C (14F) OFF	ON	OFF
< -10°C (14F) OFF	OFF	ON



6.3.2.18 Finned Coil Condenser

1. Follow the procedure in paragraph [Electrical Box], sequence 1 and 2, to remove the condenser panel.
2. Unscrew the two screws on the inner side of both frontal feet (Fig. 1).
3. Follow the procedure in paragraph [Accessing the components on the backside of the appliance], to reach the condenser fans connectors and disconnect them.
4. Unscrew the three screws on the base of the condenser conveyor (Fig. 2).
5. Unscrew the clamp and release the pipe of the refrigerant circuit from the vertical bracket and remove if necessary also, the vertical bracket (Fig. 3).
6. Unscrew the two screws from the valve to release the segment of the circuit from the compressor (Fig. 4).
7. Unwelding the joint upstream of the solenoid valve (Fig. 5).
8. On the front side of the appliance, pull out the finned coil condenser. **i** **Information** Pay attention to the wiring of the electrical box when pulling out the finned coil condenser, as the electrical box is released from the chassis (Fig. 7).

i **Information:** will be also necessary to bend a bit by hand the pipe of solenoid valve to facilitate the extraction of finned coil condenser

9. Follow the procedure in paragraph [Condenser fan], sequence 1, to remove the condenser fans.

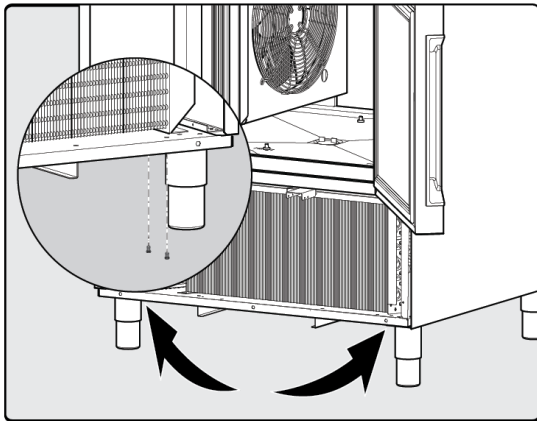

• 1.

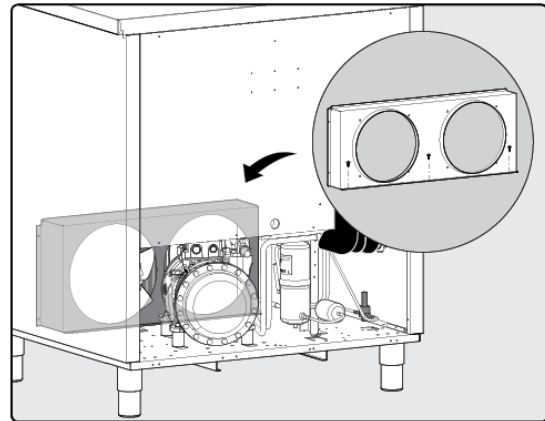

2.

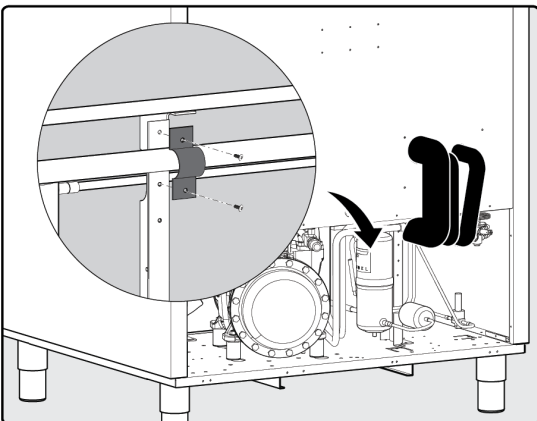

• 3.

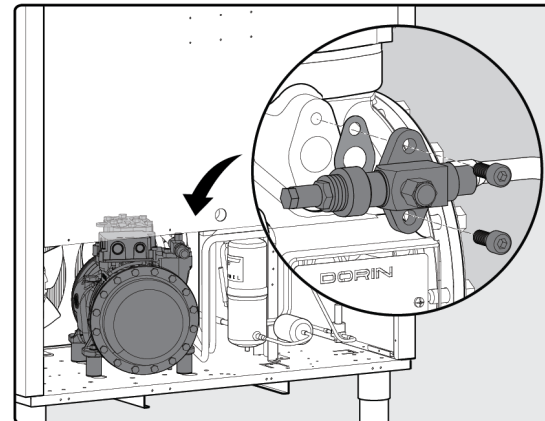

4.

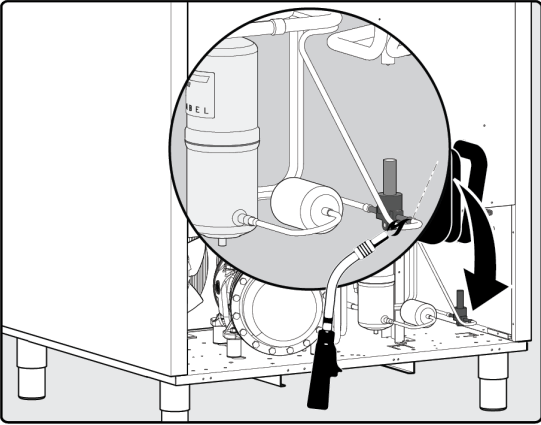
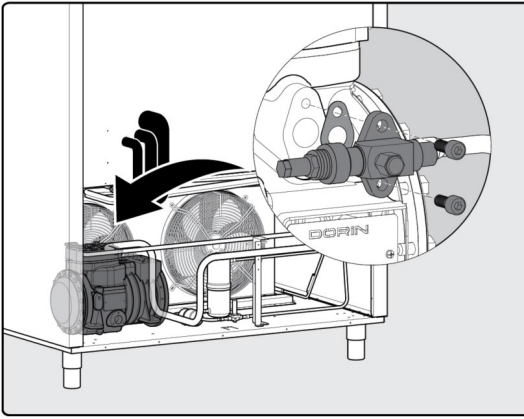
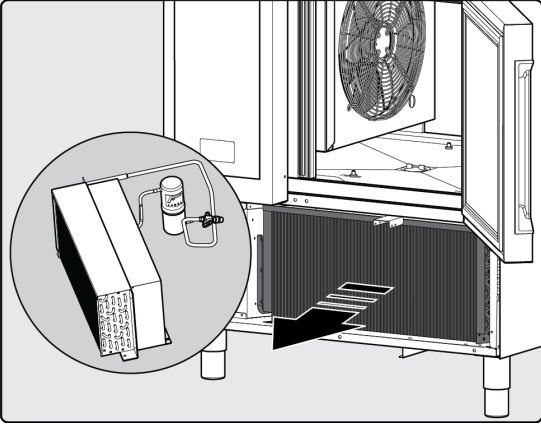

- 5. 
- 6. 
- 7. 



6.3.2.19 Condenser fan

1. Follow the procedure in paragraph [Accessing the components on the backside of the appliance] to reach the connector of the Condenser fan and disconnect it.
2. Unscrew the four screws of the bracket fan from bottom to release the motor fan and the bracket (Fig. 1)
3. Pull out the condenser fan turn left moving toward left side of compressor with a rotation of 90° as shown in figure 2.
4. To remove the second fan condenser, will be necessary to remove before the first one following the same procedure.
5. Reassembly the fan condenser in the reverse procedure.

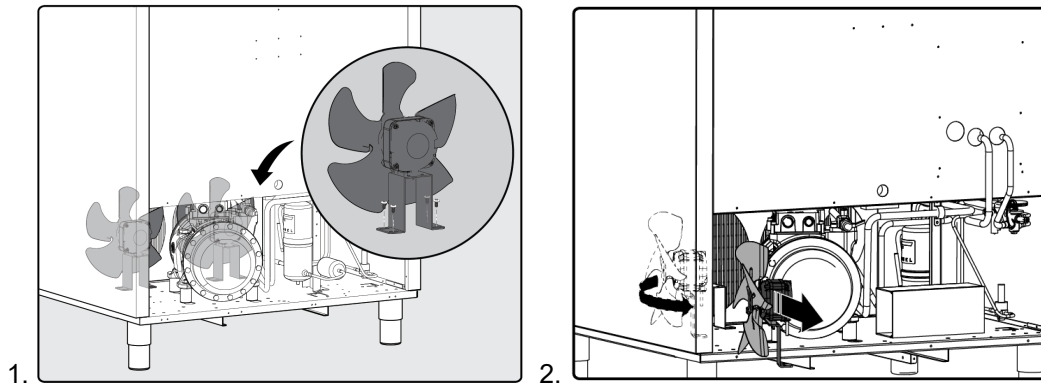

6.3.2.20 Tanic receiver

1. Follow the procedure in paragraph [Accessing the components on the backside of the appliance], sequence 1 and 2, to reach the tanic receiver.
2. Unwelding the joint upstream and downstream of the tanic receiver (Fig. 1).

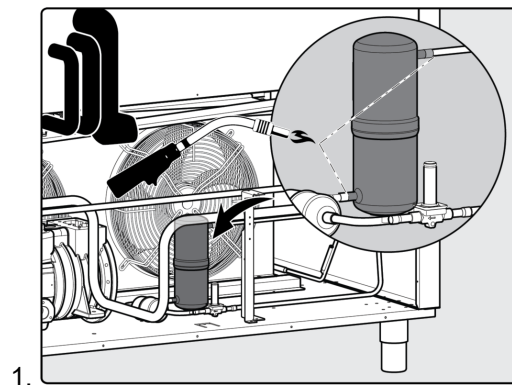

6.3.2.21 Dehydrator Filter

1. Follow the procedure in paragraph [Accessing the components on the backside of the appliance], sequence 1 and 2, to reach the Dehydrator Filter.
2. Unwelding the joint upstream and downstream of the Dehydrator Filter (Fig. 1).

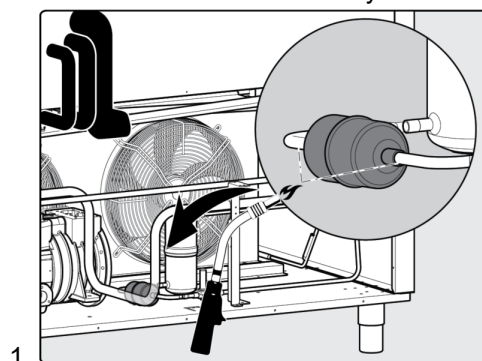



6.3.2.22 Door

1. Unscrew the four screws of the upper hinge.
2. Remove the upper hinge and the pin (Fig. 1).
3. Lift the door to remove it from the lower support.
4. Unscrew the two screws of the lower door support (Fig. 2).

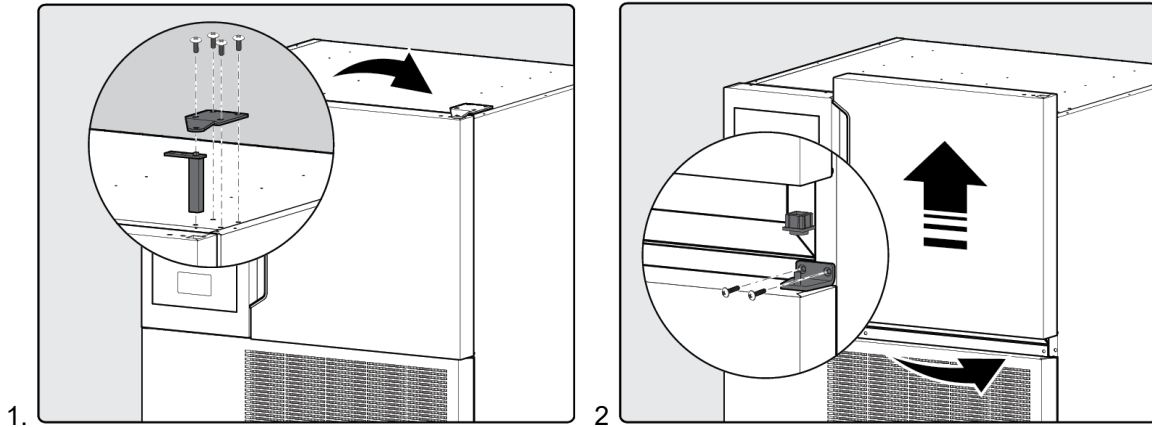

6.3.2.23 Door gasket

1. Pull out the gasket from the groove (Fig. 1)
2. Install the new one by pushing it back into the groove (see Fig. 2 for the proper insertion).

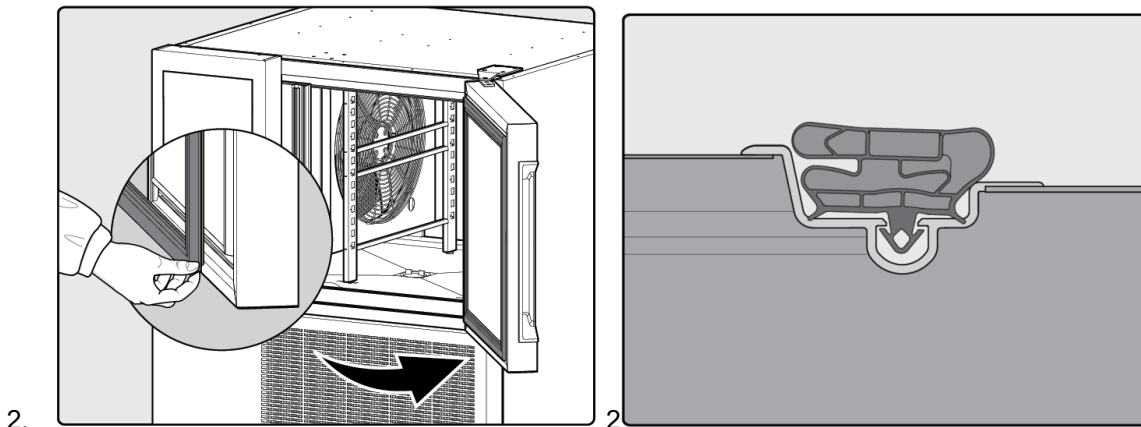

6.3.2.24 Door switch

1. Follow the procedure in paragraph [Electrical box] sequence 1 and 2 to remove the Condenser Panel.
2. Reach the door switch, unscrew the two screws and disconnect the connector (Fig. 1).

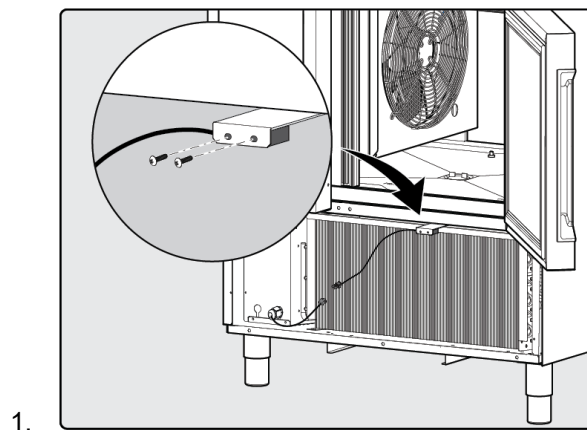



6.3.2.25 Thermostatic valve

1. Follow the procedure in paragraph [Accessing the components on the back side of the appliance],
2. Remove the insulation pipe
3. Disconnect the connectors of wiring cable
4. Remove the box protection of wiring cable,(Fig.1)
5. Disconnected the sensor of thermostatic valve and out probe, from suction pipe
6. Access to to thermostatic valve as Fig 2
7. Unwelding the thermostatic (Fig 3)
8. Wrap with a wet cloth the new thermostatic before to welding
9. Re setting the sensor and out probe evaporator in the same position of previous
10. Reassembly all part using the inverse procedure

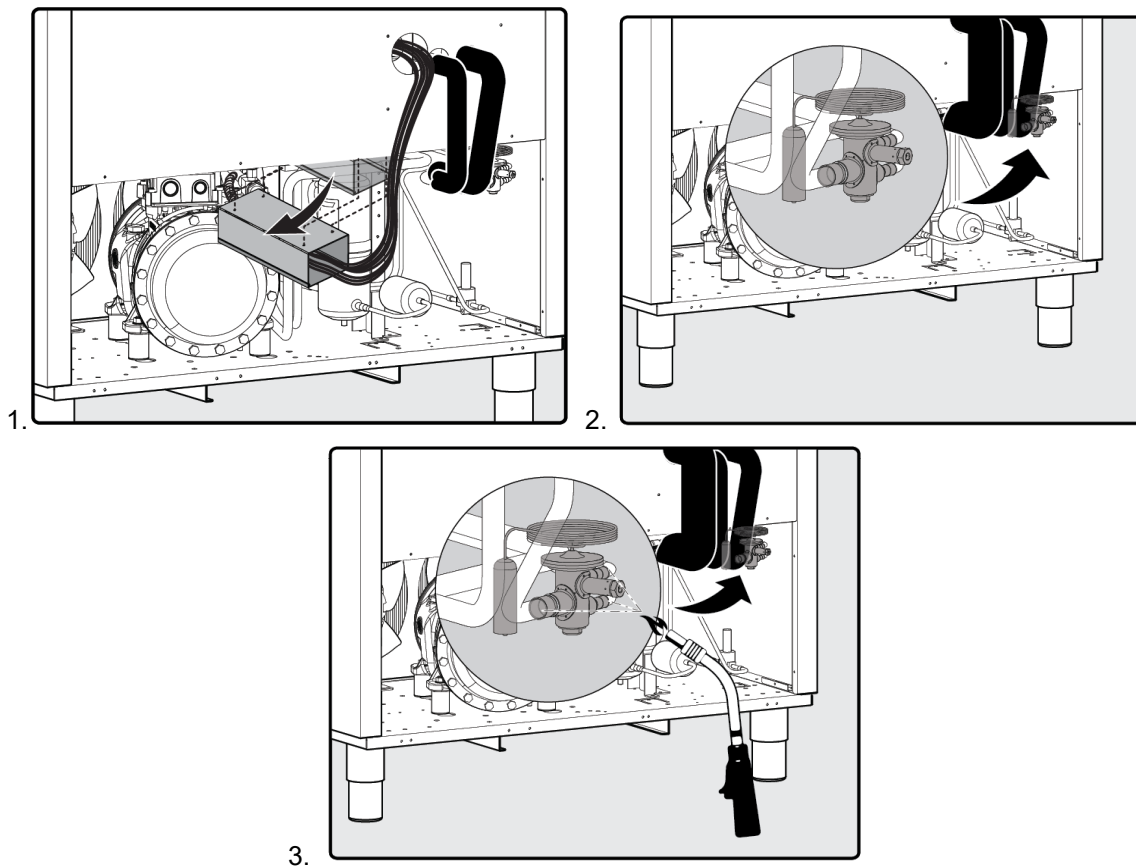



6.3.2.26 Access display and replacement of mambrane sticker



The replacement of the membrane sticker requires also the replacement of the frame, this because the glue of the membrane cannot be removed as it is a particular adesive glue/resin and once exposed to air becomes very difficult to take off and clean.

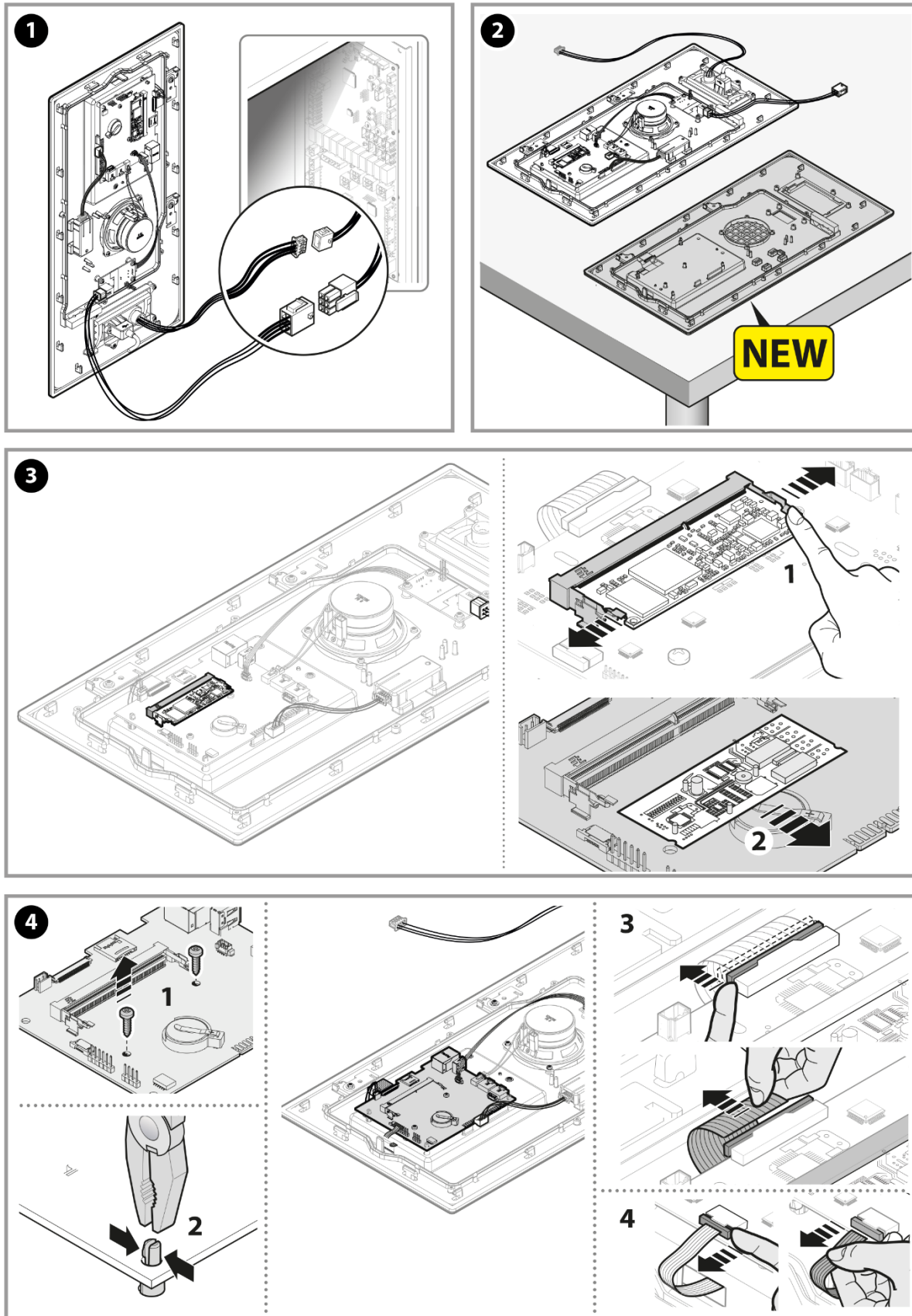

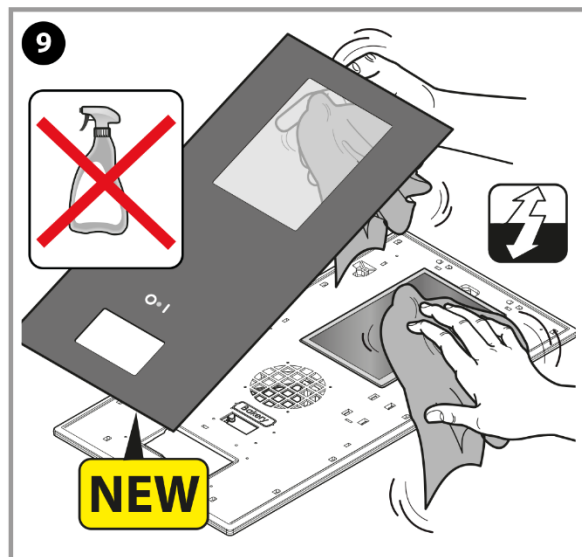
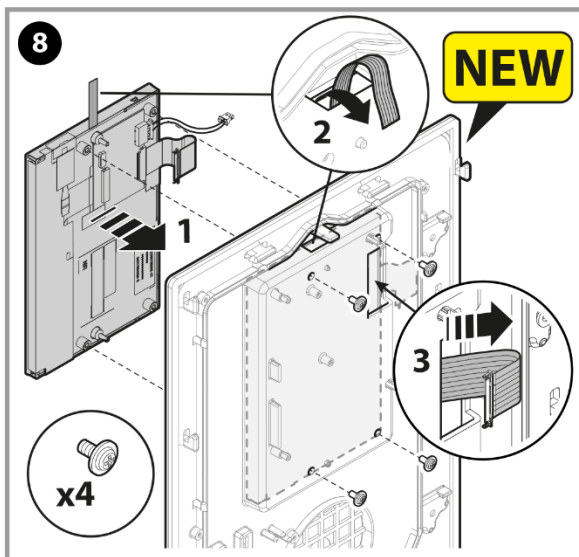
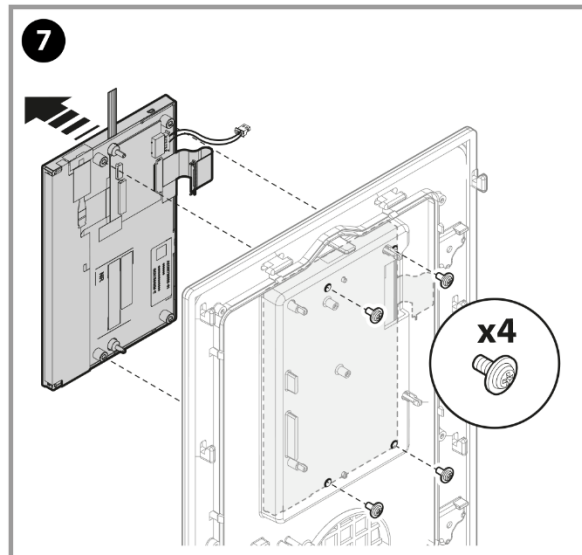
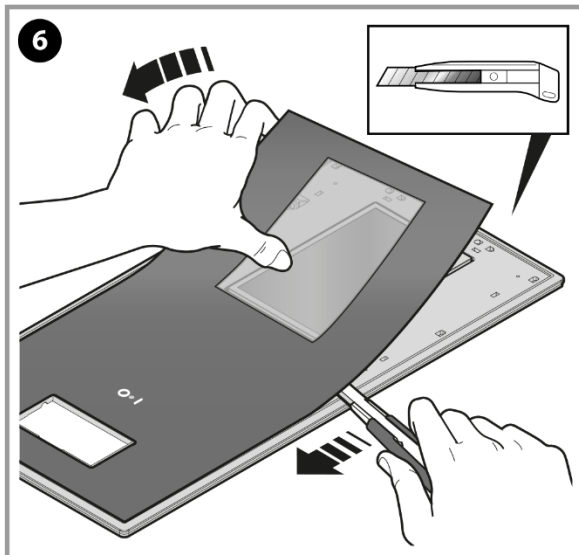
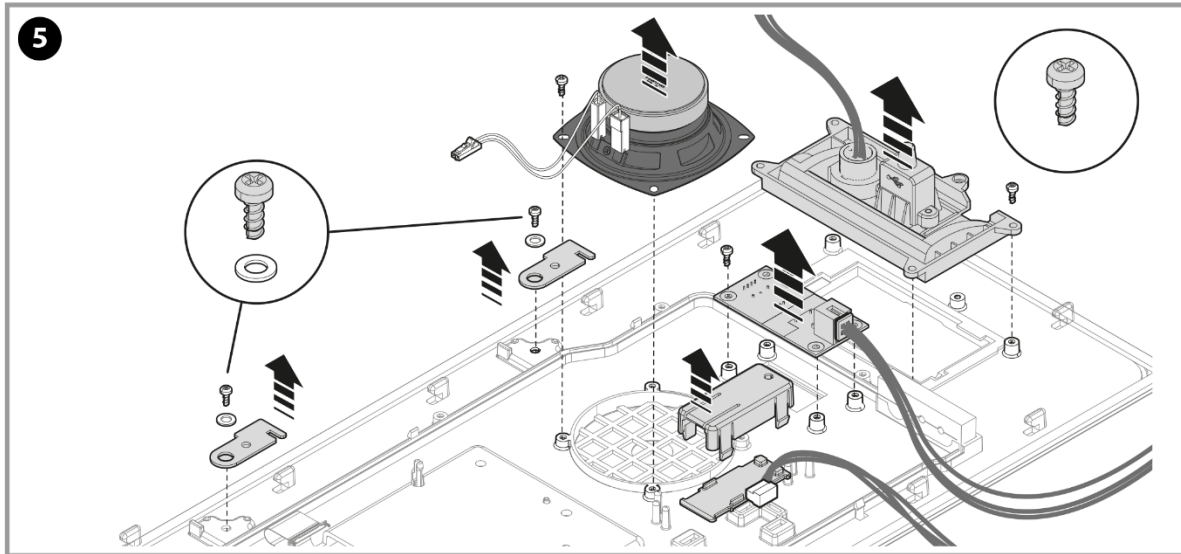

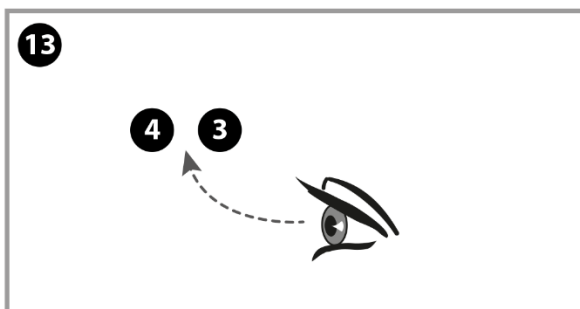
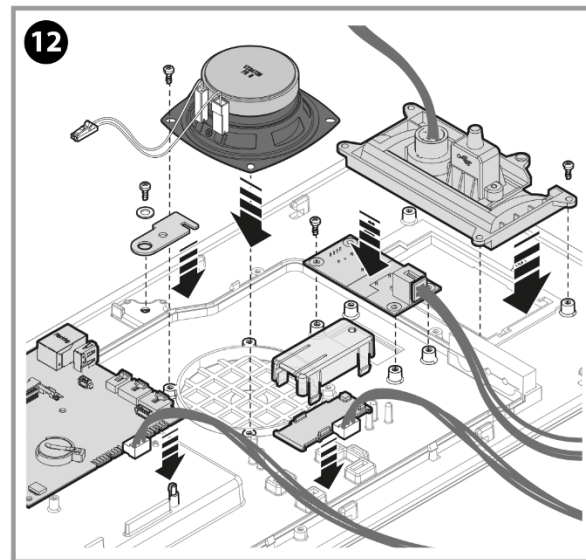
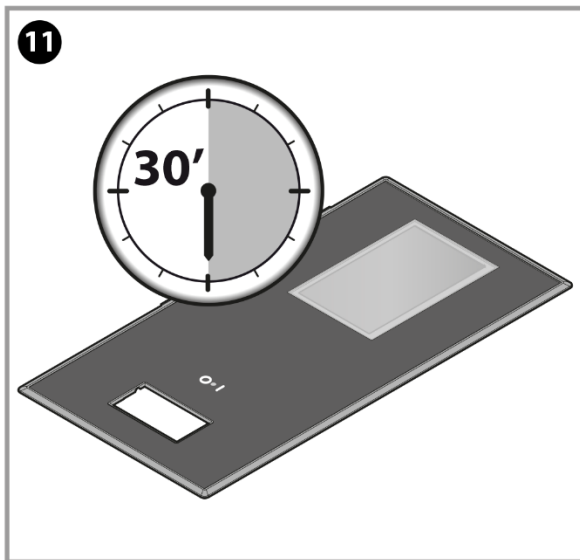
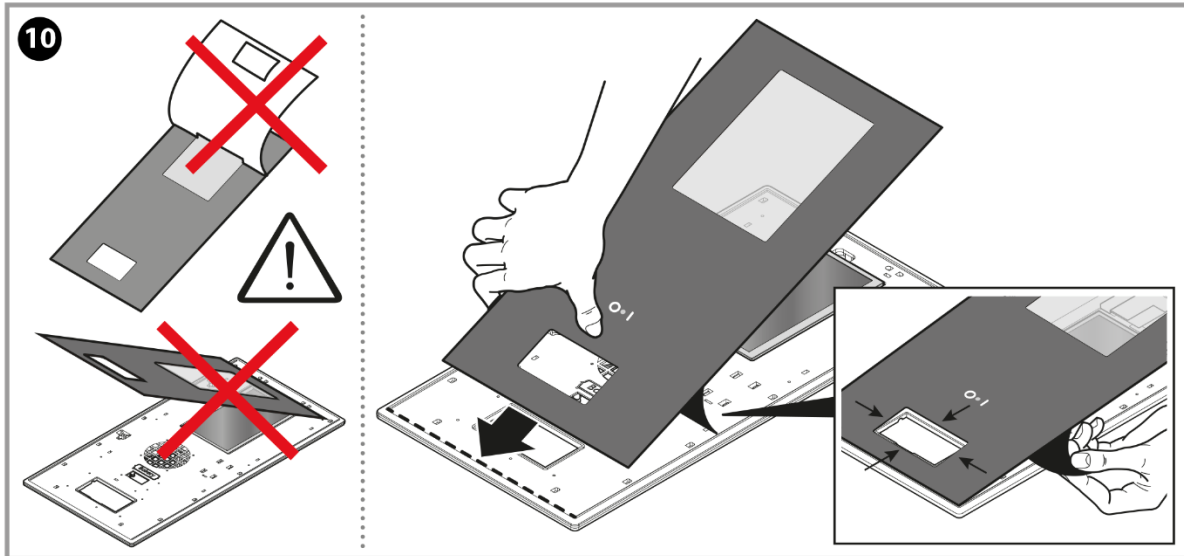

! ATTENTION!

11* = the particular adhesive glue/resin of the membrane, once exposed to air, becomes very difficult to remove. The reaction will be complete in approx. 30 minutes. In case of need to realign the new membrane time is very limited.



6.3.3 Preventive Maintenance Plan

6.3.3.1 Refert to document “Check list preventive maintenance

7. RELATED DOCUMENTS

7.1 EXPLODED VIEW

Please refer to the spare parts catalogue of the unit:

Code n°595R424.. BCF 6 gn 1/1

Code n°595R425.. BCF 10gn 1/1

Code n°595R426.. BCF 10gn 2/1

7.1.1 List Of The Vital and Wear&Tear Parts

Please refer to the Spare Parts Catalogue of the appliance, column “V = Vital spare part” – “W&T = Wear & Tear part”

7.1.2 List Of Available Accessories

Please refer to the accessories section on WEB.

7.1.3 List Of Consumables

[refert to spare part catalogue]

7.1.4 List Of Spares Wear And Tear

[refert to spare part catalogue]

7.2 ELECTRICAL WIRING DIAGRAM

Electrical wiring diagram is located in the paragraph 4

Each components has link the electrical wirind diagram

For specific wiring diagram refer to web to single unit:

EI:

Pnc of EWD to 50 _70KG code: 604R535 built in

Pnc of EWD to 50 _70KG code: 604R550 remote

Pnc of EWD to 30KG code: 604R534 built in

Pnc of EWD to 30KG code: 604R549 remote

Etc...



7.3 PARAMETERS LIST:

Parameter ID	Parameter	Description	Table	Min	Max	Default
11	FMA _n	enables/disables the Manual environment (factory setting)	{0, "Disabled"} {1, "Enabled"}	0	1	1
13	Fau _t	enables/disables the Automatic environment (factory setting)	{0, "Disabled"} {1, "Enabled"}	0	1	1
15	FPRO	enables/disables the Program environment (factory setting)	{0, "Disabled"} {1, "Enabled"}	0	1	1
17	FHGI	enables/disables the Hygiene environment (factory setting)	{0, "Disabled"} {1, "Enabled"}	0	1	1
19	FSHU	enables/disables the Skyhub environment (factory setting)	{0, "Disabled"} {1, "Enabled"}	0	1	1
21	FAG _n	enables/disables the Agenda environment (factory setting)	{0, "Disabled"} {1, "Enabled"}	0	1	1
23	FSdE	Enable Skyduo (factory setting)	{0, "Disabled"} {1, "Enabled"}	0	1	0
26	FSC _n	Show consumption estimation (factory setting)	{0, "Disabled"} {1, "Enabled"}	0	1	1
27	SCnE	Show consumption estimation (user setting)	{0, "Disabled"} {1, "Enabled"}	0	1	1
30	FENV	Selects the default environment to be loaded at startup	{0, "Manual"} {1, "Automatic"} {2, "Programs"} {3, "Hygiene"} {4, "Settings"}	0	4	0
31	FAPS	Automatic – preset saving (factory setting)	{0, "Disabled"} {1, "Enabled"}	0	1	1
32	AFS _b	Automatic – show recipe graph form (factory setting)	{0, "Disabled"} {1, "Enabled"}	0	1	0
34	APMF	Automatic – preset management (factory setting)	{0, "Disabled"} {1, "Enabled"}	0	1	1
75	FMT	Enables/disables the MultiTimer feature(factory setting)	{0, "Disabled"} {1, "Enabled"}	0	1	1
81	Mtr _t	MultiTimer temperature recovery maximum duration		0	28800	300
94	PrH	Delta for cavity set in preheating/precooling phase respect to the first phase selected		0	10	6
95	Fdu _S	Enables/disables the the format mm:ss to input the phase duration (factory setting)	{0, "Disabled"} {1, "Enabled"}	0	1	1
104	CF _d	Sets the default speed for the evaporator fan in cooling cycles		1	7	7
105	HF _d	Sets the default speed for the evaporator fan in heating cycles		1	7	2
106	COF _d	Sets the default speed for the evaporator fan in Conserve cycles		1	7	4



Parameter ID	Parameter	Description	Table	Min	Max	Default
107	CFon	Sets evaporator fan ON time when compressor is OFF. Valid only for Conserve cycles		0	18000	120
108	CFof	Sets evaporator fan OFF time when compressor is OFF. Valid only for Conserve cycles		0	18000	900
109	snLC	Minimum value for cavity set point temperature in cooling cycles		-50	125	-41
110	snHC	Maximum value for cavity set point temperature in cooling cycles		-50	125	10
111	snLH	Minimum value for cavity set point temperature in heating cycles		-50	125	-18
112	snHH	Maximum value for cavity set point temperature in heating cycles		-50	125	40
113	SCA	Cavity set point for soft chilling cycle		-50	125	0
114	SCH	Cavity set point for hard chilling cycle		-50	125	-20
115	HSP	Maximum value for cavity set point temperature in positive conserve		-50	125	10
116	MSP	Minimum value for cavity set point temperature in positive conserve and Maximum value for cavity set point temperature in negative conserve		-50	125	0
117	LSP	Minimum value for cavity set point temperature in negative conserve		-50	125	-25
121	CAL	Cavity probe calibration		-50	50	0
123	dIFP	Positive differential for compressor re-start. Reached the setpoint, the compressor will start again at 'Setpoint+DIFP'.		0	50	1
124	dIFN	Negative differential for compressor stop. Reached the setpoint, the compressor will start again at 'Setpoint-DIFN'.		0	50	1
125	dFHC	Hysteresis to switch from heating to cooling when both the modalities are enabled		0	50	2
126	dFCH	Hysteresis to switch from cooling to heating when both the modalities are enabled		0	50	5
127	nFP	Defines the total probes in the food probe for the appliance		0	6	3
128	EFP	Defines the number of separated food probes in the appliance 0: no probe available 1: only one food probe that can be 1,3 or 6 probes (according to PAR_NUM_FOOD_PRB) 2: two food probes that can be only with 3 probes each (PAR_NUM_FOOD_PRB=6) 3: two food probes that can be only with 1 probe each (PAR_NUM_FOOD_PRB=3)		0	3	1
130	dSr	Delay time before food probe or time cycle selections after evaporator fans start		0	240	30



Parameter ID	Parameter	Description	Table	Min	Max	Default
131	dPS	Delta between cavity and food probe temperature during food probe recognition		0	60	10
133	Eft	Configures appliance evaporator fans motor type. If motor without speed regulation is selected, electrical wiring and user interface will be adapted accordingly	{0, "No speed regulation"} {1, "Internal inverter"} {2, "External inverter"}	0	2	1
135	Efn	Number of evaporator fans according to appliance model. Set 0 to disable fans diagnostic		0	3	2
145	CPA	Cruise optimization percentage according to estimated time. Set 0 to disable optimization		0	100	0
146	dFRS	Door frame activation set temperature		-50	100	10
147	CdP	Minimum delay between consecutive compressor activations		0	240	120
148	CoFt	Maximum n° of hours with compressor OFF. After this time the compressor will start with impulse start-up. Set 0 to disable the impulse start-up		0	240	48
149	CnCy	Number of impulses at compressor startup		1	240	12
150	CtOn	ON time during impulse start-up		0	240	0,8
151	CtOF	OFF time during impulse start-up		0	240	8,0
164	CPE	enables/disables the compressor alarm diagnostic	{0, "Disabled"} {1, "Enabled"}	0	1	1
165	PAt	Max number compressor protection activations before to stop the cycle		1	240	10
166	PAL	Max compressor protection duration before to stop the cycle		0	600	10
167	CPt	Defines the compressor diagnostic type	{0, "Safety switch"} {1, "Thermic"}	0	1	1
168	dLEM	OFF delay of compressor after OFF flow valve during Positive/Negative conserve		0	240	4
169	dLEC	OFF delay of compressor after OFF flow valve during chilling/freezing cycles		0	240	4
170	dLCM	ON delay of flow valve during Positive/Negative conserve		0	240	4
171	dLCC	ON delay of flow valve during chilling/freezing cycles		0	240	4
172	bYVE	enables/disables the additional bypass flow valve	{0, "Disabled"} {1, "Enabled"}	0	1	0
173	bYVT	The additional bypass valve is activated if Out evaporator Temperature is greater or equal than this parameter.		-50	125	-10
174	oEEC	Calibration applied when the cavity probe is used to drive bypass valve (out evaporator error)		-50	125	0



Parameter ID	Parameter	Description	Table	Min	Max	Default
175	FSt	When the Out Evaporator temperature is higher than this parameter the evaporator fan is stopped (evaporator fan stop functionality)		-50	125	20
176	CFSt	When the cavity temp is lower than this parameter the evaporator fan stop functionality is ignored		-50	125	20
177	CoTA	Defines the condenser temperature value for the Condenser High temperature alarm		-50	125	70
178	L0Gt	Service data log sample time. If 0 log features is disabled		0	3600	1
179	tPrn	User HACCP data log sample time.		60	3600	60
180	ESStc	Enables the Germicidal cycle	{0, "Disabled"} {1, "Enabled"}	0	1	0
181	SLd	Germicidal Cycle duration		0	600	30
182	SHt	Cavity set point temperature in germicidal cycles		-50	125	40
183	dSt	Stop Evaporator temperature for Defrost		-50	125	3
184	dto	Timeout for defrost		0	600	30
185	dCt	If Cavity set point temperature is lower than this parameter, periodic evaporator defrost will not be active. Valid for Turbo cooling and positive/negative holding		-50	125	3
186	Sdln	Time interval between defrosts during turbo cooling cycle		1	240	8
187	dln	Time interval between defrosts during positive/negative holding		1	240	12
188	Iddl	Delay for the first defrost after beginning of positive/negative holding. Set 0 to disable first defrost		0	600	2
189	drt	Dripping time after defrost		0	3600	180
190	drFd	Evaporator fan delay after dripping time		0	3600	120
191	dCS	Cavity set point for drying cycles		-50	125	40
195	Pft	Power failure alarm. The alarm popup is shown if the power failure duration is greater than this parameter		0	600	10
196	Ady	Cavity High/Low temperature duration: the warning is triggered if cavity temperature is above the threshold for all this time interval (Valid only for holding cycles)		0	600	60
197	Aor	Cavity High/Low temperature warning delay after cycle start. (Valid only for holding cycles)		0	600	60
198	dFO	Cavity High/Low temperature warning delay after defrost end. (Valid only for holding cycles)		0	600	35



Parameter ID	Parameter	Description	Table	Min	Max	Default
199	HAC	Cavity High temperature threshold: the warning is triggered if Cavity Temperature > (Cavity Set + HAC). Valid only for holding cycles.		-50	125	5
200	LAC	Cavity Low temperature threshold: the warning is triggered if Cavity Temperature < (Cavity Set - LAC). Valid only for holding cycles.		-50	125	5
201	Afd	Cavity High/Low temperature differential: the High temperature warning is resettled if Cavity Temperature is less or equal than (Cavity Set + HAC - Afd). Low Temperature warning is resettled if Cavity Temperature is greater or equal than (Cavity Set - LAC + Afd)		-50	125	1
202	bCoF	enables/disables the fan to cooling electronic boards	{0, "Disabled"} {1, "Enabled"}	0	1	1
203	ERLO	External resistor load to be used for energy consumption calculation. [ohm]		0	50000	0
204	NVOL	Nominal appliance voltage supply. Used for energy consumption calculation (heaters) [V]		0	500	230
205	POFF	Power consumption offset . Used for energy consumption calculation [W]		0	50000	0
206	REm	Defines if the cooling unit is remote or on board	{0, "On board"} {1, "Remote"}	0	1	0
207	APPM	Appliance model	{0, "LW 30 Kg"} {1, "LW 50 Kg"} {2, "LW 70 Kg"} {3, "LW 100 Kg"} {4, "LW 150 Kg"} {5, "LW 200 Kg"}	0	5	0
208	APPT	Appliance type: defines if the appliance is only a blast chiller (BC) or a blast chiller and freezer (BCF)	{0, "BC"} {1, "BCF"}	0	1	1
210	dEMo	Enables/disables different demo modes. · Disabled: the appliance behaves normally; · Basic: the appliance simulates the normal behaviour. All temperatures are internally simulated, there is no need of an ACU connection; · Exhibition: the appliance simulates the normal behaviour except the door sensing which is retrieved from real sensor ; · Development: all the appliance features are simulated. Temperatures and digital inputs are sent to target through a serial port	{0, "Disabled"} {2, "Exhibition"} {3, "Development"} {4, "Remote view"}	0	4	0
212	StF	Show display touch feedback on screen	{0, "Disabled"} {1, "Enabled"}	0	1	1
213	LAIP	enables/disables the Wizard procedure at startup (factory setting)	{0, "Disabled"} {1, "Enabled"}	0	1	1
222	SHMF	Skyhub – configuration management: add and delete (factory setting)	{0, "Disabled"} {1, "Enabled"}	0	1	1





Electrolux
P R O F E S S I O N A L

Electrolux Professional SpA

Sede legale

Viale Treviso, 15

33170 Pordenone, ITALY

Fax (+39) 0434 380 201 <http://professional.electrolux>