

## CONTENTS

<b>I. INSTALLATION DIAGRAM / JOINING APPLIANCES / TABLES</b> .....	<b>2</b>
<b>II. DATAPLATE and TECHNICAL DATA</b> .....	<b>20</b>
<b>III. GENERAL INSTRUCTIONS</b> .....	<b>21</b>
<b>IV. THE ENVIRONMENT</b> .....	<b>22</b>
<b>V. INSTALLATION</b> .....	<b>22</b>
1. REFERENCE STANDARDS .....	22
2. UNPACKING .....	22
3. POSITIONING .....	23
4. FUME EXHAUST AND VENTILATION .....	23
5. CONNECTIONS .....	23
6. BEFORE COMPLETING INSTALLATION OPERATIONS .....	24
<b>VI. USER INSTRUCTIONS</b> .....	<b>25</b>
1. GRILL USE .....	25
2. SWITCHING ON .....	25
3. TRAY USE .....	25
<b>VII. CLEANING</b> .....	<b>25</b>
1. PERIODICAL CLEANING .....	25
2. IDLE PERIODS .....	26
3. INTERNAL PARTS .....	26
<b>VIII. MAINTENANCE</b> .....	<b>27</b>
1. MAINTENANCE .....	27

## II. DATAPLATE and TECHNICAL DATA

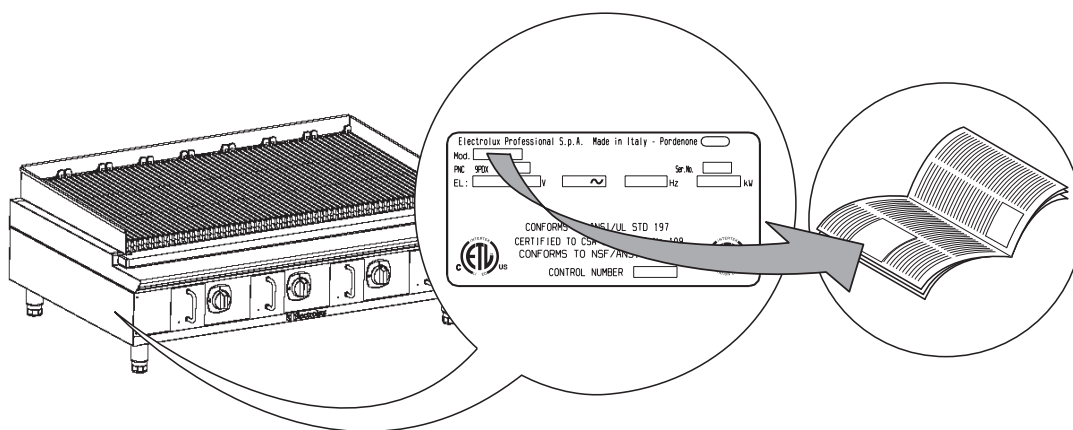

### IMPORTANT

This manual contains information relevant to various appliances. See the appliance dataplate located under the control panel in order to identify the appliance (see fig. above).

TABLE A - Gas appliance technical data						
TECHNICAL DATA		MODELS	169020 AGG12 305mm/12"	169021 AGG24 610mm/24"	169022 AGG36 915mm/36"	169023 AGG48 1220mm/48"
Gas connection	Ø		3/4"	3/4"	3/4"	3/4"
Burners	Nr		1	2	3	4
Nominal heat output	kW		9.65	19.3	28.9	38.6
	Btu/h		33000	66000	99000	132000

### III. GENERAL INSTRUCTIONS



- Read the instruction handbook carefully before using the appliance.

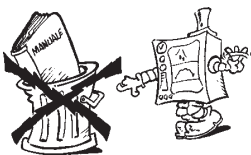

- Keep the instruction handbook for future reference.



- **RISK OF FIRE** - Keep the area around the appliance free and clear of combustibles. Do not keep flammable materials in the vicinity of the appliance.



- Inadequate ventilation causes asphyxia. Do not obstruct the ventilation system in the place where this appliance is installed. Do not obstruct the vents or ducts of this or other appliances.



- Place emergency telephone numbers in a visible position.
- Keep the instructions to be followed in case of smell of gas in the room in a visible position. This information is available from the gas company.

- Installation and maintenance must only be carried out by qualified personnel authorised by the manufacturer. For assistance, contact an authorised service centre. Demand original replacements parts.
- This appliance is designed for cooking food. It is intended for industrial use. Any use different from that indicated is **improper**.
- This appliance is not intended for use by people (including children) with limited physical, sensory or mental abilities or without experience and knowledge of it, unless they are supervised or instructed in its use by a person responsible for their safety.
- Personnel using the appliance must be **trained**. Do not leave the appliance unattended when in use.
- Turn the appliance off in case of a fault or poor operation.
- Do not use products (even if diluted) containing chlorine (sodium hypochlorite, hydrochloric or muriatic acid, etc.) to clean the appliance or the floor under it. Do not use metal tools to clean steel parts (wire brushes or Scotch Brite type scouring pads).



- Do not allow oil or grease to come into contact with plastic parts.
- Do not allow dirt, fat, food or other residuals to form deposits on the appliance.
- Do not clean the appliance with direct jets of water.

- The symbol  given on the product indicates that it should **not** be treated as domestic waste, but must be correctly disposed of in order to prevent any negative consequences for the environment and the health of people. For further information regarding the recycling of this product, contact the product agent or local dealer, the after-sales service or the local body responsible for waste disposal.

- **Attention:**
  - Do not use or store petrol or other flammable liquids, gases or materials in the vicinity of this or other appliances
  - Do not use sprays near this appliance while it is operating.
  - This appliance is not suitable for marine environments

**Failure to observe the above can compromise the safety of the appliance. Failure to observe the above invalidates the warranty.**

## IV. THE ENVIRONMENT

### 1. PACKING



The packing materials are environmentally friendly and can be stored without risk or burned in an appropriate waste incineration plant. Recyclable plastic parts are marked with:



**Polyethylene:** outer wrapping, instruction booklet bag, gas nozzle bag.



**Polypropylene:** roof packing panels, straps.



**Polystyrene foam:** corner protectors.

### 2. USE

Our appliances offer high performance and efficiency. To reduce electricity, water or gas consumption, do not use the appliance empty or in conditions that compromise its optimum efficiency; the appliance must be used in a well-ventilated place, to avoid the creation of dangerous mixtures of unburnt gases in the room. When possible, preheat only before use.

### 3. CLEANING

In order to reduce the emission of pollutants into the environment, clean the appliance (externally and when necessary internally) with products that are more than 90% biodegradable (for further information refer to section VII "CLEANING").

### 4. DISPOSAL



Do not disperse in the environment. Our appliances are manufactured using more than 90% (in weight) recyclable metals (stainless steel, iron, aluminium, galvanised sheet, copper, etc.).

Make the appliance unusable by removing the power cable and any compartment or cavity closing devices (when present) in order to avoid the risk of someone becoming trapped inside.

## V. INSTALLATION



• Carefully read the installation and maintenance procedures given in this instruction manual before installing the appliance.

- Installation, maintenance and conversion to another type of gas must only be carried out by qualified personnel authorised by the manufacturer.
- Failure to observe the correct installation, conversion and modification procedures can result in damage to the appliance, danger for people, and invalidates the Manufacturer's warranty.

### 1. REFERENCE STANDARDS

- This appliance must comply with the applicable federal, state or local regulations. These installation procedures must be carried out by qualified personnel, otherwise the warranty will be invalidated. The NFPA (National Fire Protection Association) Inc states, in its latest 96 edition, that the local regulations are the "competent authority" regarding the installation requirements for appliances. Therefore, all connections (gas, electrical, water, discharges, etc.) must comply with all the local regulations.
- In the lack of local regulations, installation must be carried out in compliance with the "National Fuel Gas Code", ANSI Z223.1/NFPA 54, or the "Natural Gas and Propane Installation Code", CSAB 149.1, in particular:
  - 1) the appliance must be disconnected from the gas supply during any operation on the system pressure exceeding 1/2 psi (35 mbar/3.5 kPa).
  - 2) the appliance must be isolated from the gas supply during any operation on the system pressure below or equal to 1/2psi (35 mbar/3.5 kPa).

### 2. UNPACKING

#### ATTENTION!

**Immediately check for any damage caused during transport.**

- The forwarder is responsible for the safety of the goods during transport and delivery.
- Inspect the packing before and after unloading.
- Make a complaint to the forwarder in case of visible or hidden damage, reporting any damage or shortages on the dispatch note upon delivery.



• The driver must sign the dispatch note: the forwarder can reject the claim if the dispatch note is not signed (the forwarder can provide the necessary form).

- Unpack, taking care not to damage the appliance. Wear protective gloves.
- Carefully remove the protective film from metal surfaces and clean any traces of glue with a suitable solvent.
- For hidden damage or shortages becoming apparent only after unpacking, request the forwarder for inspection of the goods within and not later than 15 days of delivery.
- Keep all the documentation contained in the packing.

### 3. POSITIONING

- Handle the appliance with care in order to avoid damage or danger to people. Use a pallet for handling and positioning.
- The installation diagram provided in this instruction manual gives the appliance dimensions and the position of connections. Check that they are available and ready for making all the necessary connections.
- The appliance can be installed separately or combined with other appliances of the same range.
- The appliances are not designed for built-in installation; ensure a distance of at least 8"/203.2 mm from the rear wall, to allow connection and aeration of the burners; in case of any combustible side walls, leave at least 6"/152.4 mm, otherwise (non-combustible walls) they can be brought near (0"/0 mm).
- Suitably insulate any surfaces that are at distances less than those indicated in the installation diagram.
- Do not store or use flammable materials and liquids near the appliance.
- Check and if necessary level the appliance after positioning. Incorrect levelling can cause appliance malfunctioning.

#### 3.1. JOINING APPLIANCES (Fig. 1A- 1B-1C-1D-1E-1F)

- Remove knobs "M" and control panels "C" of the appliances, removing the 4 fixing screws "V" (Fig. 1A).
- Remove the precut "PT" (FIG.1B) from each side to be joined.
- Bring the appliances together and level them by turning the feet until the tops match (FIG.1C).
- From inside the control panel of the appliances, join them at the front part, tightening one M5x40 hex head screw on the nut (supplied) (FIG.1D).
- Remove the screws "V" (FIG.1E).
- Position the plate "P" to match the holes and fix it using the screws supplied (FIG.1F).
- Refit the control panels and knobs.
- Use NSF silicone to seal the gaps between joined appliances and tops on refrigerated or compartment base.

### 4. FUME EXHAUST AND VENTILATION

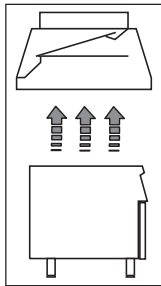

- Only install the appliance in a well-ventilated place.
- Do not obstruct the ventilation system in any way.
- Do not obstruct the vent and discharge holes of this appliance or others present in the room.

**ATTENTION! Inadequate ventilation causes appliance malfunction and creates the risk of asphyxia and danger to people.**

### 5. CONNECTIONS



- Any installation work or maintenance to the supply system must only be carried out by the utility company or an authorised installer.
- Refer to the appliance dataplate for the product code.
- See the installation diagram for the type and position of appliance connections.

#### 5.1. GAS APPLIANCES

**IMPORTANT!** This appliance is arranged and tested to operate on Natural gas (G20, 7mbar/3"wc); to convert it to another type of gas, follow the instructions in par. 5.1.6. of this section.

##### 5.1.1. BEFORE CONNECTING

- Make sure the appliance is arranged for the type of gas to be used. Otherwise, follow the instructions given in the section: "Gas appliance conversion / adjustment".
- Fit a rapid gas shut-off cock/valve ahead of each appliance. Install the cock/valve in an easily accessed place.

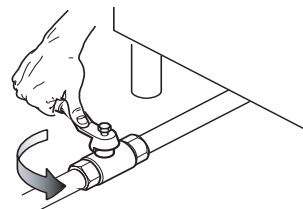

- Clean the pipes to remove any dust, dirt or foreign matter which could block the supply.
- The gas supply line must ensure the gas flow necessary for full operation of all the appliances connected to the system. A supply line with insufficient flow will affect correct operation of the appliances connected to it.

##### 5.1.2. CONNECTION

- See the installation diagram for the position of the gas connection on the bottom of the appliance.
- Remove the plastic protection cover (if present) from the appliance gas union before connecting.
- After installation, use soapy water to check connections for leaks.

##### 5.1.3. SUPPLY PRESSURE CHECK

Make sure the appliance is suitable for the type of gas available, according to that specified on the dataplate (otherwise, follow the instructions in par. "Conversion to another type of gas"). The supply pressure must be measured with the appliance operating, using a manometer (min. 0.1 mbar).

- Remove the control panel.
- Remove screw "N" from the pressure point and connect the pressure gauge "O" (fig. 2A).
- Compare the value read on the manometer with that given in Table B (see handbook Appendix)
- If the manometer gives a pressure outside the range of values in Table B, do not use the appliance. Consult the gas company.

**5.1.4 GAS PRESSURE REGULATOR**

- A gas pressure regulator (supplied in a plastic bag with the appliance) must be installed in an easily accessed position ahead of the appliance.

The pressure regulator should preferably be fitted horizontally, to ensure the right outlet pressure:

- “1” connection side gas from mains.
- “2” pressure regulator (3.3"x2.9"x2.7" / 85x75x71mm);
- “3” connection side gas towards the appliance;

The arrow on the regulator (→) indicates the gas flow direction.

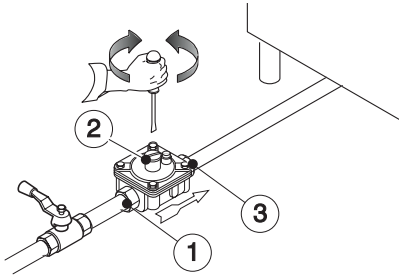

**NOTE!** These models are designed and certified for use with natural or propane gas. For natural gas, the pressure regulator on the manifold is set to 7mbar.

**5.1.5. PRIMARY AIR CHECK**

When the primary air supply is correctly adjusted, the flame does not “float” with burner cold and there is no flareback with burner hot.

- Undo screw “A” and position aerator “E” at distance “H” given in table B; retighten screw “A” and seal with paint (fig. 3A).

**5.1.6. CONVERSION TO ANOTHER TYPE OF GAS**

Table B “Technical data/gas nozzles” gives the types of nozzles (contained in a bag supplied with the appliance, together with the pressure regulator) to be used when replacing those fitted by the manufacturer; the number is stamped on the nozzle body.

At the end of the procedure, carry out the following check-list:

Check	Ok
• burner nozzle/s change	
• correct adjustment of primary air at burner/s	
• pilot nozzle/s change	
• minimum flame screw/s change	
• correct adjustment of pilot/s, if necessary	
• correct adjustment of supply pressure (see technical data/gas nozzles table)	
• apply the sticker (supplied) with data of new gas type used	

**5.1.6.1 BURNER NOZZLE REPLACEMENT (fig. 3A)**

- Loosen screw “A” and move bushing “E” to unscrew and replace nozzle “C” with one suitable for the type of gas to be used, according to that given in Table B.
- The nozzle diameter is given in hundredths of mm on the nozzle body.
- Tighten down nozzle “C”.
- Refit bushing “E” according to distance H (Table B), and tighten down screw “A”

**5.1.6.2 MINIMUM FLAME SCREW REPLACEMENT (fig. 2A)**

- Unscrew minimum flame screw “M” from the cock and replace it with one suitable for the type of gas (screw down fully) (Table B, see appendix).

**6. BEFORE COMPLETING THE INSTALLATION OPERATIONS**

Use soapy water to check all gas connections for leaks. DO NOT use a naked flame to check for gas leaks. Light all the burners individually and also together, to check correct operation of the gas valves, rings and lighting. For each burner, adjust the flame regulator to the lowest setting, individually and together; after completing the operations, the installer must instruct the user on the correct method of use. If the appliance does not work properly after carrying out all the checks, contact the local after-sales service centre.

## VI OPERATING INSTRUCTIONS

### 1. GRILL USE

- The appliance is intended for industrial use by trained personnel.
- Do not use the appliance empty for long periods or in conditions that compromise its optimum efficiency. Also, if possible, preheat the appliance immediately before use.
- The grill is designed for direct cooking of food on the hot-plate (hamburgers, chops, eggs, sausages, fish, vegetables, etc.). Any other use is deemed improper.
- Empty the oil collection container every day before use (if necessary, empty it several times a day).
- Do not use the grill to heat pots or pans.
- **Grill 305mm/12"**: it consists of a single cooking zone controlled by a gas valve.
- **Grill 610mm/24"**: it consists of two cooking zones (left and right side) controlled by two gas valves, one for each zone.
- **Grill 915mm/36"**: it consists of three cooking zones (left, middle and right side) controlled by three gas valves, one for each zone.
- **Grill 1220mm/48"**: it consists of four cooking zones (from left to right) controlled by four gas valves, one for each zone.

### 2. SWITCHING ON/OFF

The gas control knob "A" of each burner has 3 positions:

- "Off"
- "On"
- "Max. flame"
- "Min. flame"

#### Lighting

- Remove the front tray "C" to access the pilot.
- Press down and turn knob "A" to "★"; at the same time, hold a flame to the pilot from outside. The flame must remain alight when knob "A" is released; otherwise, repeat the operation.

#### Lighting the main burner

- Turn knob "A" from "★" to "🔥".
- For minimum, turn knob "A" to "🔥".

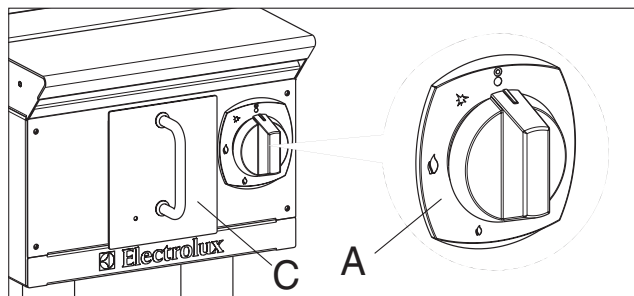

#### Switching off

- Press and turn knob "A" to "●".
- At the end of the day, close the gas cock located ahead of the appliance.

### 3. TRAY USE

- For better cooking results and to facilitate cleaning at the end of the day, it is advisable to pour a little water into each grease collection tray.

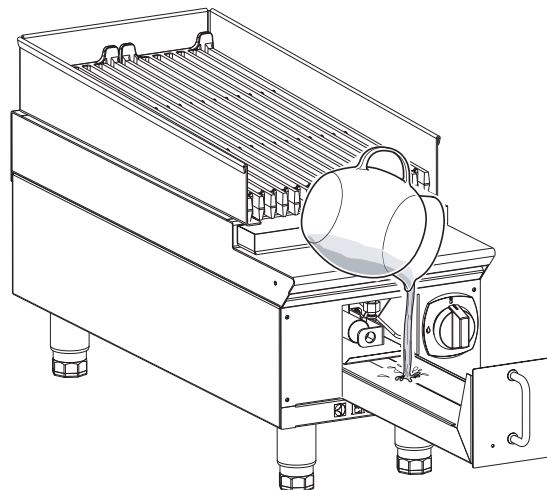

**ATTENTION:** The tray can become very hot, therefore handle it using suitable protection to avoid burns.

## VII. CLEANING

### 1. EXTERNAL PARTS

#### SATIN-FINISH STEEL SURFACES (daily)

- Clean all steel surfaces: dirt is easily removed when it has just formed.
- Remove grime, fat and other cooking residuals from steel surfaces when cool using soapy water, with or without detergent, and a cloth or sponge. Dry the surfaces thoroughly after cleaning.
- In case of encrusted grime, fat or food residuals, go over with a cloth or sponge, wiping in the direction of the satin finish and rinsing often: rubbing in a circular motion combined with the particles of dirt on the cloth/sponge could spoil the steel's satin finish.
- Metal objects can spoil or damage the steel: damaged surfaces become dirty more easily and are more subject to corrosion.
- Restore the satin finish if necessary.

#### SURFACES BLACKENED BY HEAT (when necessary)

Exposure to high temperatures can cause the formation of dark marks. These do not constitute damage and can be removed by following the instructions given in the previous section.

#### OTHER SURFACES

##### SURFACES IN SOFT IRON OR CAST IRON (daily)

Remove grime using a damp cloth or, in case of encrustations, the accessories (optional or supplied) specified in the list. After cleaning, switch the appliance on to dry the surface quickly, then lightly lubricate the surface with cooking oil.

**COLLECTION TRAYS AND TANKS** (even several times a day)  
Remove grease, oil, food residuals, etc. from tanks, trays and containers in general used for collection. Always clean these containers at the end of the day. While using the appliance, empty them when they are nearly full.

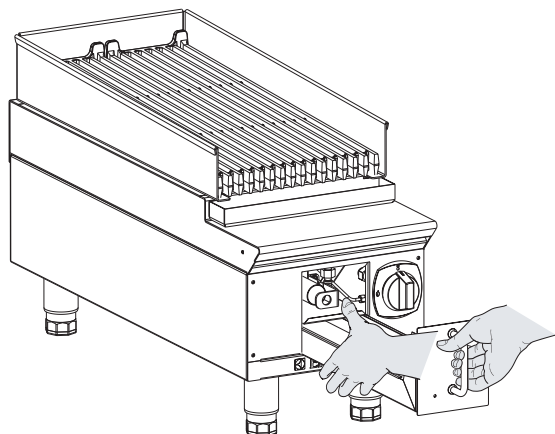

### 1.1 CLEANING THE BURNER AND COMBUSTION CHAMBER

- (figure 1) Remove cooking grills "A" by simply lifting them.
- (figure 2) Lift splash guard "B" to release it from the tabs of splash guards "C", then move it forward to remove.
- (figure 3) Lift splash guards "C" to remove them.
- (figure 4) Remove protection cover "D" by lifting it.
- (figure 5) Remove radiant panel "E", lifting it out of its seat.
- (figure 6) Remove panels "F" by lifting them.

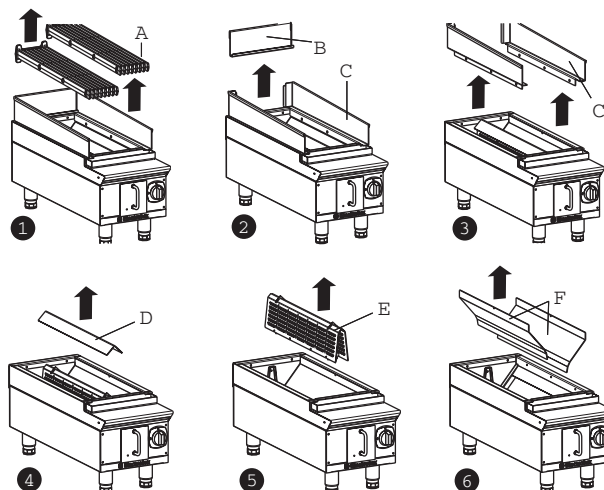

- (figure 7) Clean the burner around the flame zone and along the slots of the flame protector, removing all traces of dust and deposits, taking care not to enlarge the flame holes.

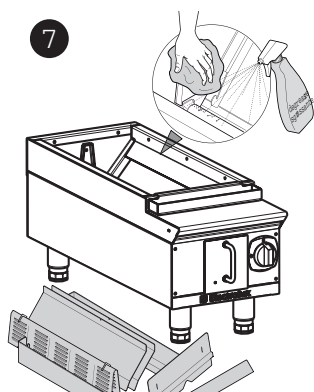

- Using a scraper or similar tool, clean the combustion chamber ribs that run the juices into the collection tray, then go over with a damp cloth. During this operation take care not to damage the pilot flame igniter assembly.
- After carrying out cleaning operations make sure the burner and combustion chamber are perfectly clean and dry, then carefully refit the previously removed parts, ensuring that:
  - holes "G" of panels "F" are at the top;

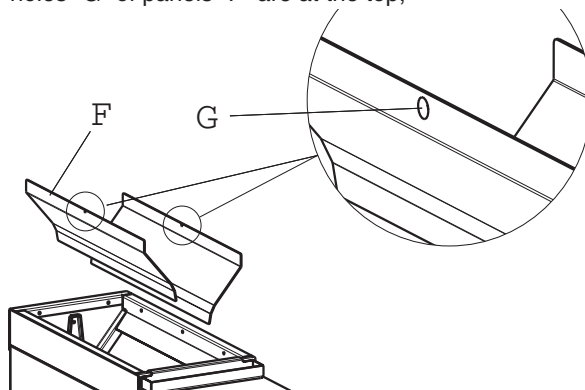

- radiators "R" are resting on their supports "S".

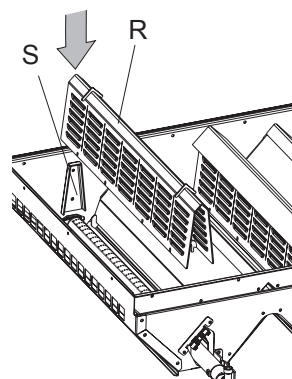

### 1.2 SPLASH GUARDS, PANELS, PROTECTION COVERS

Remove the splash guards, panels and protection covers from the appliance, as described in the previous section, and place them in a bowl full of hot soapy water, with or without detergent.

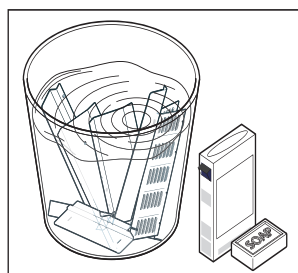

### 1.3 GRILLS

#### • ROUTINE CLEANING (after every use)

Remove food residuals with a damp cloth and neutral surfactants; if necessary, remove charred deposits using brush with NON-metallic bristles.

After cleaning, switch the appliance on to dry the surface quickly, then lightly lubricate the surface with cooking oil.

- **PERIODICITY** (every two months or more often in case of prolonged use of the appliance)  
Lubricate the entire surface with cooking oil, then switch the appliance on at minimum until all the oil is evaporated/absorbed.

- **OXIDISED AREAS** (when necessary)

Eliminate any oxidised areas with abrasive paper (glass abrasive, NEVER metallic) and immediately repeat the “periodicity” treatment.

## 2. IDLE PERIODS

If the appliance is not going to be used for some time, take the following precautions:

- Close cocks or main switches ahead of the appliance.
- Go over all stainless-steel surfaces vigorously with a cloth moistened with paraffin oil in order to create a protective film.
- Air the premises periodically.
- Have the appliance checked before using it again.

## 3. INTERNAL PARTS (every 6 months)

**IMPORTANT! Operations to be carried out only by specialised technicians.**

- Check the condition of internal parts.
- Remove any deposits of dirt inside the appliance.
- Check and clean the discharge system.
- Remove the 4 fixing screws “V” of back “S” to access the inner rear part of the appliance.

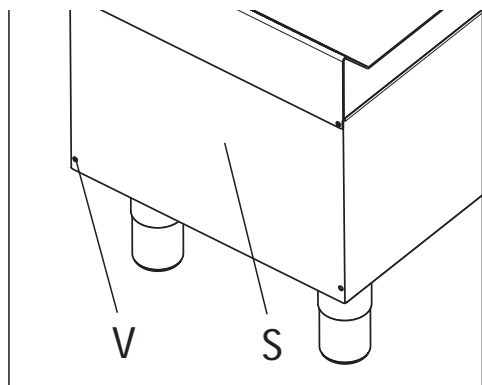

**NOTE !** In particular conditions (e.g. intensive appliance use, salty environment, etc.) the above cleaning should be more frequent.

# VIII MAINTENANCE

## 1. MAINTENANCE

All parts requiring maintenance are accessible from the front of the appliance, after removing the control panel.

### 1.1 BRIEF TROUBLESHOOTING GUIDE

Even with normal use, malfunctions can occur.

*The pilot burner does not light*

**Possible causes:**

- Insufficient pressure in gas pipes.
- Faulty gas valve.

*The pilot burner goes out when the igniter knob is released*

**Possible causes:**

- The pilot burner is not heating the thermocouple sufficiently.
- Faulty thermocouple.
- The gas valve knob is not being pressed enough.
- Lack of gas pressure at the valve.
- Faulty gas valve.

*The pilot burner is still lit but the main burner does not light*

**Possible causes:**

- Loss of pressure in gas pipe.
- Blocked nozzle or faulty gas valve.
- Burner with gas outlet holes clogged.

### INSTRUCTIONS FOR REPLACING PARTS

(to be carried out only by a specialised installer)

#### VALVE

- Remove the knobs and control panel.
- Unscrew the pilot and thermocouple pipe.
- Unscrew the gas inlet and outlet connections.
- For installation carry out the same procedure in reverse order.

#### THERMOCOUPLE, PILOT BURNER ASSEMBLY

- Remove the knobs and control panel.
- Unscrew the pilot and thermocouple pipe and remove it.
- Replace the part.

#### GRILL MAIN BURNER

- Remove the knobs and control panel.
- Remove the clamp fixing the burner to the gas pipe and nozzle holder.
- Remove the burner and replace it.

For installation carry out the same procedure in reverse order.

### 1.2 MAINTENANCE SCHEDULE

- It is advisable to have the appliance inspected by an authorised person at least every 12 months. For this purpose, it is advisable to stipulate a servicing contract.