

Service Manual

Solid Door Upright Reach-In Units: ESR1, ESRH2, **ESR2**, ESWR2, ESR3
ESF1, ESFH2, ESF2, ESWF2, ESF3
ESRF2, ESWQ3, ESWRF2, ESRF3
ESR1D2, ESR2D2, ESR2D4
ESRF2D2, ESWQ2D2



www.EVERESTref.com

201 W. Artesia Blvd, Compton, CA 90220
T. (310) 323-6586, (800) 444-6285
F. (310) 323-7524, (310) 761-1127

1. Safety Precautions	1
2. Refrigeration Cycle	2
3. Maintenance	3
3.1 Interior and Exterior Cleaning	
3.2 Condenser Cleaning	
4. Installation	4
5. Specifications	
5.1 – 5.3 Product Drawings	5-7
5.2 Data Sheets	8-9
6. Wiring Diagrams	10-13
7. Electronic PCB Control	
7.1 Display (User Interface)	14
7.2 Display LED Symbols	14
7.3 Button Symbols	14
7.4 Checking and changing operating values	14
7.5 Manual defrost ON/OFF	14
7.6 Parameter setting	14
7.7 Parameter setting (“C” parameter)	15
7.8 Table of alarms and signals	15
7.9 Table of easy parameters	15-16
8. Service Instructions	
8.1 Control Box Assembly	
8.1.1 How to Disassemble Control Box Assembly	17-18
8.1.2 Electronic Controller	19
8.1.3 How to Remove Electronic Controller	20
8.1.4 Power Cord Set	20

8.2 Condensing Unit Assembly	
8.2.1 How to Remove Condensing Unit Assembly	20
8.2.2 How to Remove Compressor	21-22
8.2.3 Compressor Technical Data (FFI10-HAKW)	23
8.2.4 Compressor Technical Data (NE2134GK)	24
8.2.5 Compressor Troubleshooting	25
8.2.6 Condenser Fan Motor Assembly	26
8.2.7 Evaporator Fan Motor And Bi-Metal	27
8.2.8 Defrost Heater	28
8.2.9 Over Heat Protector	29
8.3 Interior Light and Switch	
8.3.1 Light Bulb Cover	30
8.3.2 Light Bulb Socket	30-31
8.3.3 Door/Light Switch	32-33
8.4 Evaporator Cover Assembly	34
8.4.1 Drain Pan Heater	35
8.5 Condensate Drain Pan Heater Assembly	36
8.5.1 Condensate Drain Pan Heater	37
8.6 How to Check Heater	38-39
8.7 Door	
8.7.1 How to Remove Door Assembly	40-41
8.7.2 Door Tension Adjustment	42
8.7.3 Door Gasket	43
9. Diagnostics	
9.1 Service Diagnostic Chart	44-46

1. Safety Precautions

1. The power cable should be unplugged before replacing or repairing any electrical parts.
2. When replacing electrical parts, rated parts must be used.
 - The procedure also requires that specifications such as model, rated voltage, rated current and operating temperature are precisely matched.
3. Use appropriate tools when replacing parts.
4. Coupling harnesses and lead wirings should be connected without exposing the core strip.
5. When servicing the unit, dust or other impurities must not come in contact with the wiring assembly in the housing.
6. Check for moisture marks on all electrical parts.
 - If moisture marks exist, it is recommended that you replace the part(s) or take measures in preventing further moisture exposure.
7. Check assembly state of parts after service.
 - Ensure that it matches the assembly state before service.
8. If operation seems unstable, it is recommended that you change the unit's location.
 - Unit must be installed in a temperature regulated room with low humidity and away from heat sources or combustible products.
9. Determine whether the unit should be grounded.
 - It should be grounded if you determine that moisture or water exposure may cause an electrical leakage.
10. High energy consumption products such as heaters should have exclusive outlets. Avoid having several power plugs in one outlet.

2. Refrigeration Cycle

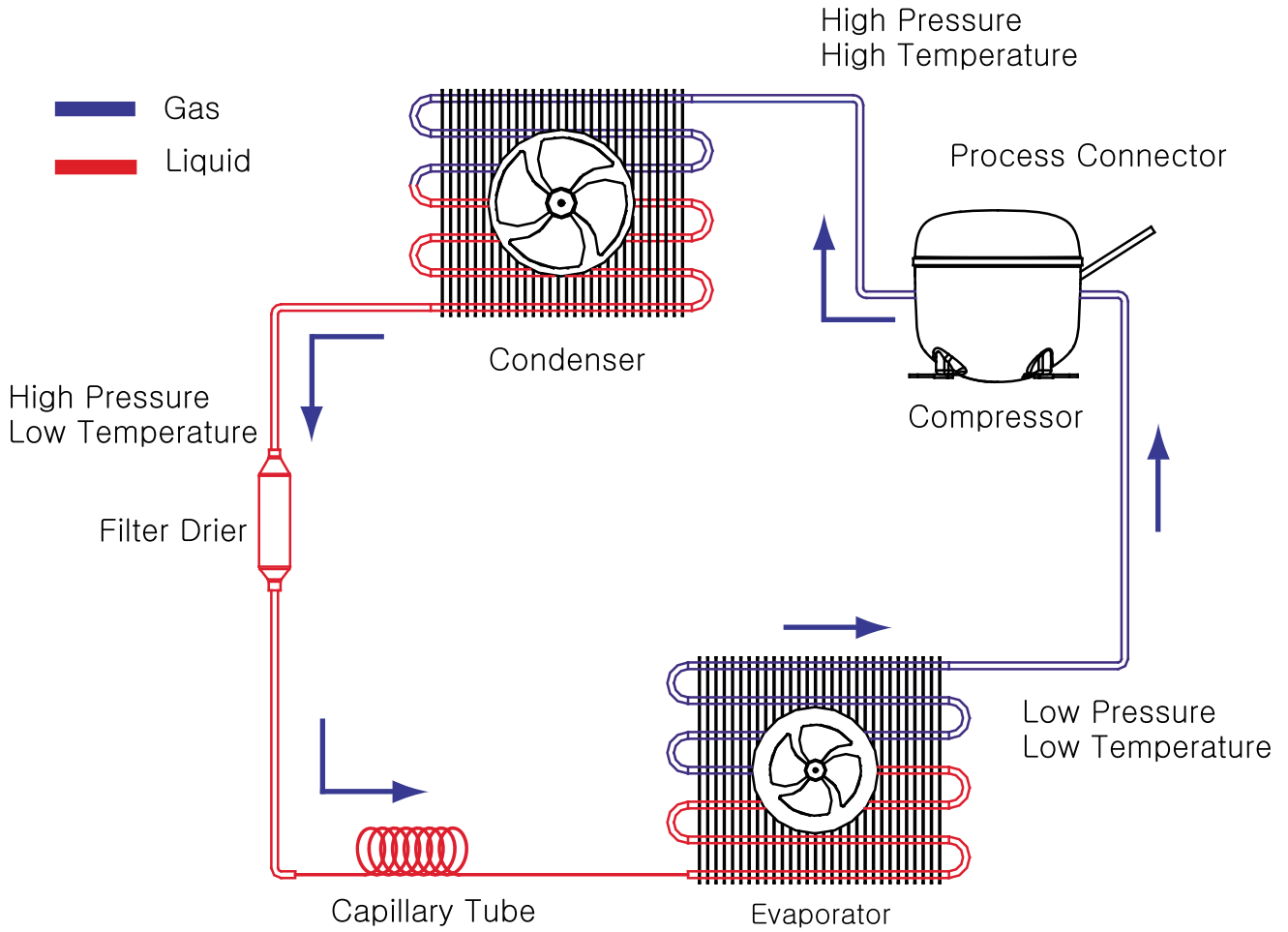

Fig 3-1

3. Maintenance

3.1 Cleaning the Interior and Exterior

Use ONLY stainless steel cleaners in cleaning the interior and exterior of the cabinet.

WARNING • The unit's exterior stainless steel surface is made of 430 series material which will rust if exposed to non-stainless steel cleaners.

CAUTION • Never use steel wool, strong acids, or abrasive cleaners when cleaning the exterior or interior of the unit.
• Acidic products or products containing vinegar must be stored in sealed containers to prevent acid damage to the interior of the cabinet and the evaporator coil.

3.2 Cleaning the Condenser Coil

IMPORTANT : Use this procedure to clean the condenser at least once a month.

A dirty condenser coil restricts airflow, resulting in excessively high operating temperatures. This reduces the unit's efficiency and shortens component life.

WARNING • Disconnect electrical power to the unit before cleaning the condenser.
• The condenser fan blade is sharp. Be careful when cleaning.

CAUTION • If you are cleaning the condenser fan blades, cover the fan motor to prevent water damage.

Clean the outside of the condenser with a soft brush or a vacuum brush. Clean from top to bottom, not from side to side. Shine a flashlight through the condenser to check for dirt between the fins. If dirt remains:

- a. Blow compressed air through the condenser coil.
- b. Use a commercial condenser coil cleaner. Follow the directions and any precautions supplied with the cleaner.

Repeat Step 2 until all dirt is removed.

Carefully wipe off the fan blade and motor with a soft cloth. Do not bend the fan blades. If the fan blades are excessively dirty, wash with warm, soapy water and rinse thoroughly.

4. Installation

1. The unit must be installed with casters provided on a level surface.

CAUTION : Temperature and drainage issues will occur if the product is tilted forward or backward. If necessary, adjust the height of the caster(s) by using washers to ensure that the unit is leveled.

2. The product is designed for indoor and commercial use. Outdoor installation will cause a decrease in performance and result in significant damage if exposed to sunlight and rain.
3. Do not install the unit under a shelf or any location where a foreign object could fall into the condensing unit area or the top of the cabinet.
4. Select a location away from heat and moisture generating equipment such as a stove, oven, dish washer, etc.
5. Minimum Clearance Requirements [Figure 4-1]
Top : 20" above the condensing unit
Back & Side : 6" at the back and each side
6. Do not tilt the unit during delivery and installation. Compressor oil might run into the condensing coil through the high pressure pipe, which causes a pressure problem due to clogs in the capillary tube.

CAUTION : If the minimum clearance requirements are not maintained, the unit's cooling capacity will be reduced. This may lead to product loss or premature component failure.

7. The four casters supplied by the manufacturer must be installed.
Failure to do so will cause a malfunction in the condensate pan heater located underneath the cabinet.
8. Ambient Temperature for Condenser
Minimum : 50 °F
Maximum : 90 °F

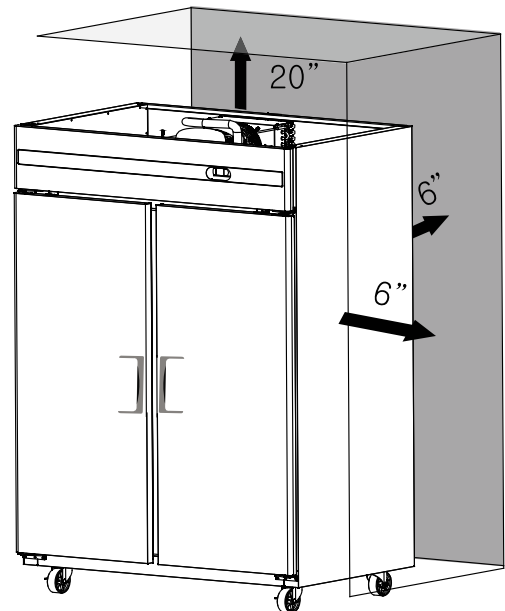
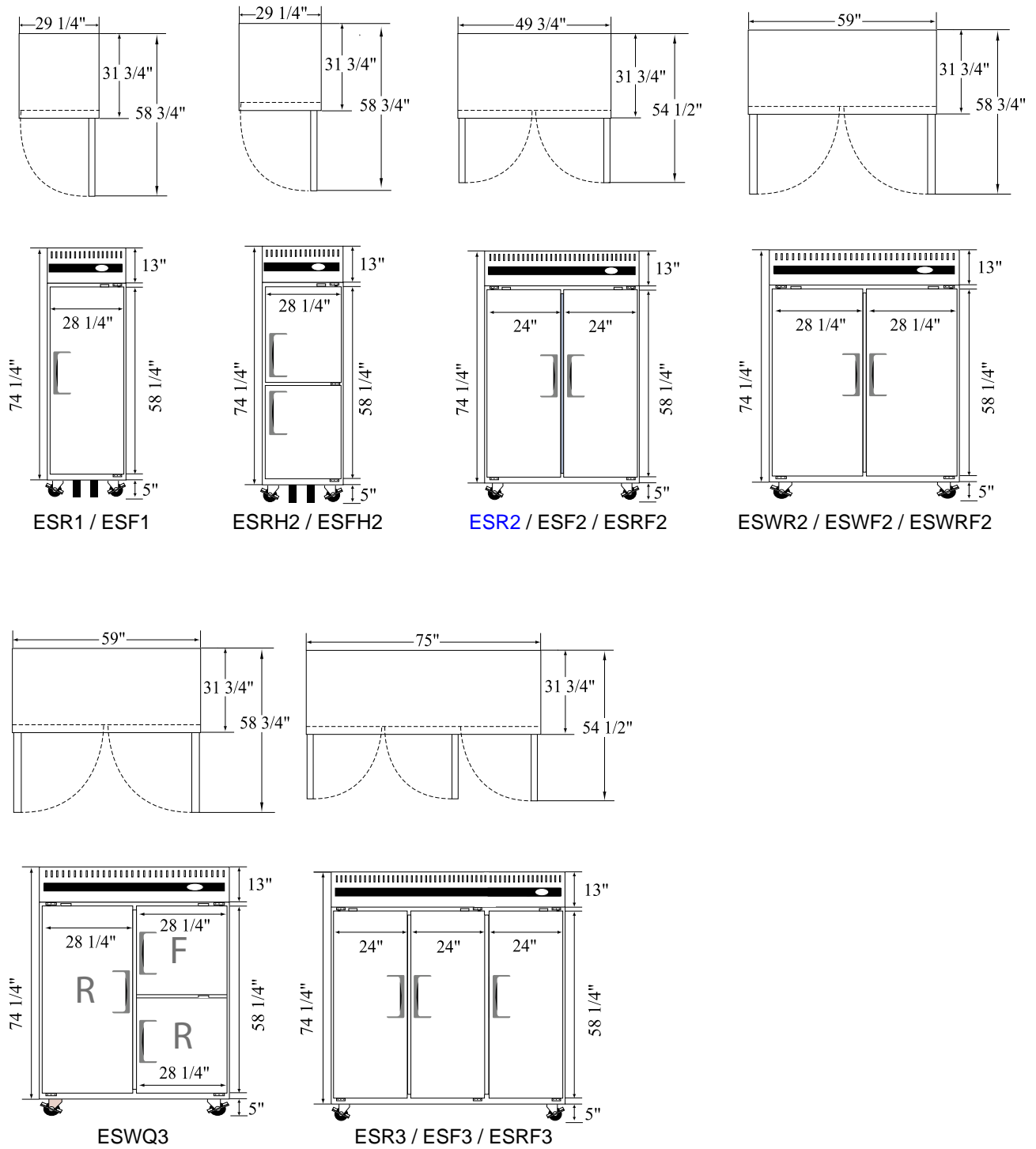

Fig 4-1

5. Specifications

5.1 Product Drawings: Solid Door Upright Reach-Ins



5. Specifications – Continued

5.2 Product Drawings: Door & Drawer Combo Upright Reach-Ins

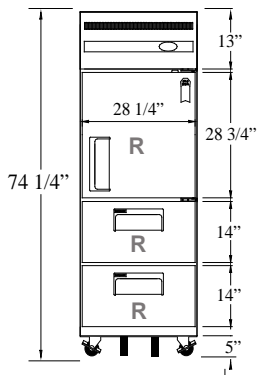
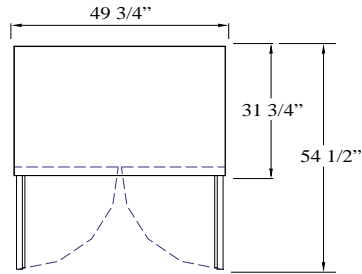
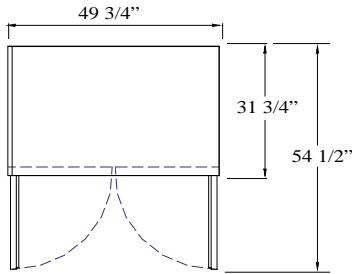
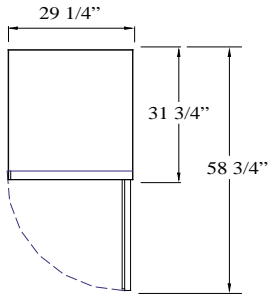

ESR1D2

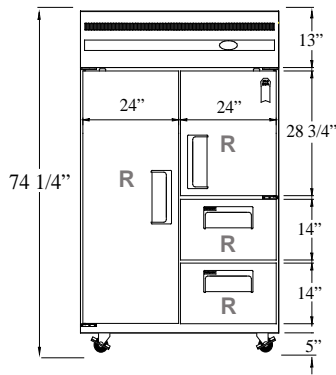

ESR2D2

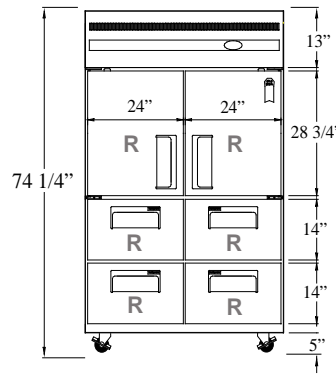

ESR2D4

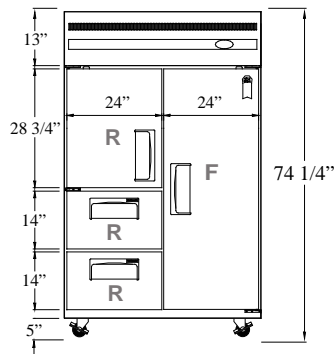
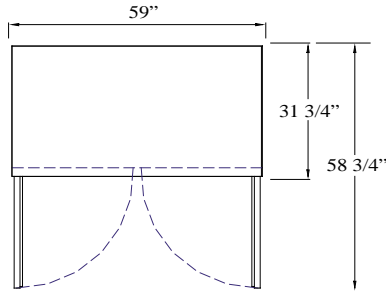
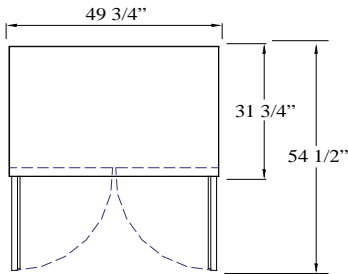

ESRF2D2

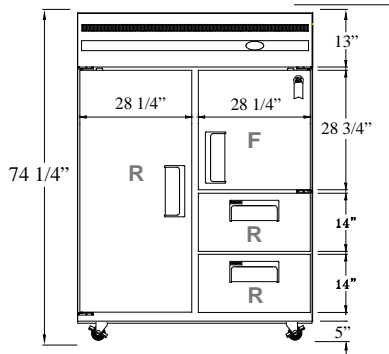

ESWQ2D2

5. Specifications – Continued

5.3 Product Drawings: Glass Door Upright Reach-Ins

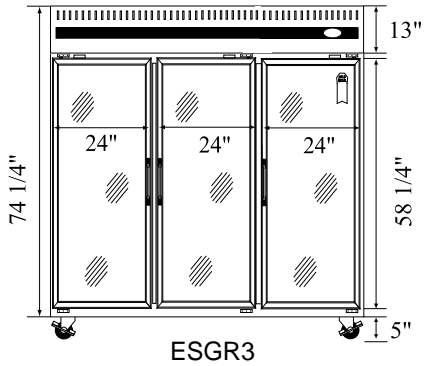
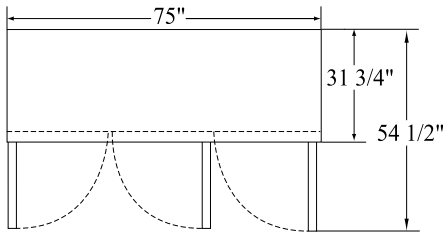
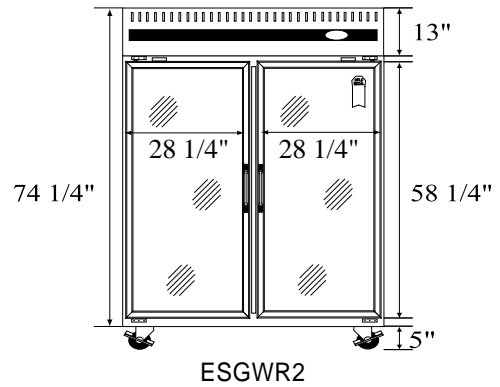
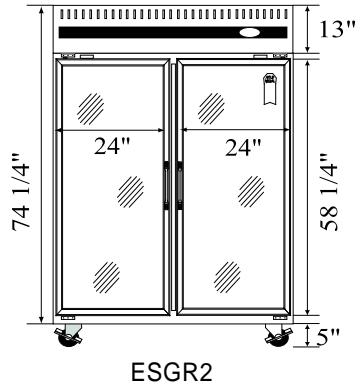
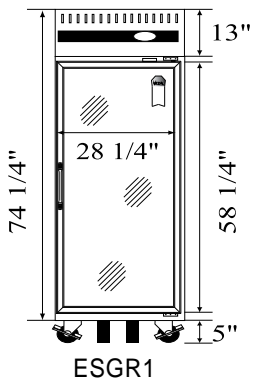
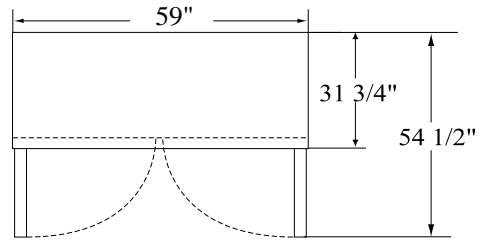
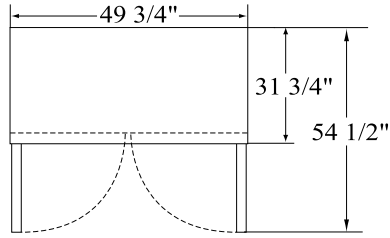
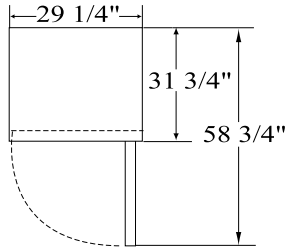

5. Specifications – Continued

5.4 Data sheets

Model	ESR1 (Refrigerator)	ESF1 (Freezer)	ESRH2 (Refrigerator)	ESFH2 (Freezer)	ESR2 (Refrigerator)	ESF2 (Freezer)
Capacity(Cu.Ft.)	23	23	23	23	48	48
Door	1	1	2 (Half)	2(Half)	2	2
Shelves	3	3	3	3	6	6
Compressor (HP)	1/3	1/2	1/3	1/2	1/3	1/2 x 2ea
Compressor Model	FFI10HAKW	NE2134GK	FFI10HAKW	NE2134GK	FFI10HAKW	NE2134GK
Refrigerant (Oz)	13.05	13.05	13.05	13.05	13.05	13.05 x 2ea
Pressure of suction during operation cycle at setting temp	10 to 15 pounds	10 to 15 pounds	10 to 15 pounds	10 to 15 pounds	10 to 15 pounds	10 to 15 pounds
Power (V-Hz-Ph)	115-60-1	115-60-1	115-60-1	115-60-1	115-60-1	115-60-1
Temp. Range(F)	32 ~ 42	-4 ~ 32	32 ~ 42	-4 ~ 32	32 ~ 42	-4 ~ 32
Refrigerant	R-134a	R-404a	R-134a	R-404a	R-134a	R-404a
Crated Weight(LBS)	284	289	289	293	384	448
Amps(A)	3.38	8.12	3.38	8.12	4.50	15.89
Ext. Dimensions (W x D x H inches)	29 1/4 x 31 3/4 x 74 1/4	29 1/4 x 31 3/4 x 74 1/4	29 1/4 x 31 3/4 x 74 1/4	29 1/4 x 31 3/4 x 74 1/4	49 3/4 x 31 3/4 x 74 1/4	49 3/4 x 31 3/4 x 74 1/4

Model	ESRF2 (Dual Temp)	ESWR2 (Refrigerator)	ESWF2 (Freezer)	ESWRF2 (Dual Temp)	ESWQ3 (Dual Temp)	ESR3 (Refrigerator)
Capacity(Cu.Ft.)	22(R) 22(F)	55	55	26(R) 26(F)	39(R) 13(F)	71
Door	2	2	2	2	2	3
Shelves	6	6	6	6	5	9
Compressor (HP)	1/3(R) 1/2(F)	1/3	1/2 x 2ea	1/3(R) 1/2(F)	1/3(R)X 2ea	1/3 x 2ea
Compressor Model	FFI10HAKW (R) NE2134GK (F)	FFI10HAKW	NE2134GK	FFI10HAKW (R) NE2134GK (F)	FFI10HAKW	FFI10HAKW
Refrigerant (Oz)	13.05(R) 13.05(F)	13.05	13.05 x 2ea	13.05(R) 13.05(F)	13.05(R) 12.35(F)	13.05 x 2ea
Pressure of suction during operation cycle at setting temp	10 to 15 pounds	10 to 15 pounds	10 to 15 pounds	10 to 15 pounds	10 to 15 pounds	10 to 15 pounds
Power (V-Hz-Ph)	115-60-1	115-60-1	115-60-1	115-60-1	115-60-1	115-60-1
Temp. Range(F)	32~42(R) -4~32(F)	32 ~ 42	-4 ~ 32	32~42(R) -4~32(F)	32~42(R) -4~32(F)	32 ~ 42
Refrigerant	R-134a(R) 404a(F)	R-134a	R-404a	R-134a(R) 404a(F)	R-134a(R) 404a(F)	R-134a
Crated Weight(LBS)	456	421	503	496	470	578
Amps(A)	12.85	4.50	15.89	12.08	12.08	9.49
Ext. Dimensions (W x D x H inches)	49 3/4 x 31 3/4 x 74 1/4	59 x 31 3/4 x 74 1/4	59 x 31 3/4 x 74 1/4	59 x 31 3/4 x 74 1/4	59 x 31 3/4 x 74 1/4	75 x 31 3/4 x 74 1/4

Note: R - Refrigerator F - Freezer

5. Specifications – Continued



5.4 Data sheets – Continued

Model	ESF3 (Freezer)	ESRF3 (Dual Temp)	ESR12D2 (Refrigerator)	ESR2D2 (Refrigerator)	ESR2D4 (Refrigerator)	ESRF2D2 (Dual Temp)
Capacity(Cu.Ft.)	71	46(R) 22(F)	23	48	48	22(R) 22(F)
Door	3	3	1(Half) 2(Drawer)	1(Full) 1(Half) 2 (Drawer)	2(Half) 4 (Drawer)	1(Full) 1(Half) 2 (Drawer)
Shelves	9	9	2	5	3	5
Compressor (HP)	1/2 x 3ea	1/3(R) 1/2(F)	1/3	1/3	1/3	1/3(R) 1/2(F)
Compressor Model	NE2134GK	FFI10HAKW (R) NE2134GK (F)	FFI10HAKW	FFI10HAKW	FFI10HAKW	FFI10HAKW (R) NE2134GK (F)
Refrigerant (Oz)	13.05 x 3ea	13.05(R) 13.05(F)	13.05	13.05	13.05	13.05(R) 13.05(F)
Pressure of suction during operation cycle at setting temp	10 to 15 pounds	10 to 15 pounds	10 to 15 pounds	10 to 15 pounds	10 to 15 pounds	10 to 15 pounds
Power (V-Hz-Ph)	230-60-1	115-60-1	115-60-1	115-60-1	115-60-1	115-60-1
Temp. Range(F)	-4 ~ 32	32~42(R) -4~32(F)	32 ~ 42	32 ~ 42	32 ~ 42	32~42(R) -4~32(F)
Refrigerant	R-404a	R-134a(R) 404a(F)	R-134a	R-134a	R-134a	R-134a(R) 404a(F)
Crated Weight(LBS)	650	589	366	423	534	531
Amps(A)	12.36	12.62	4.94	5.30	5.55	12.50
Ext. Dimensions (W x D x H inches)	75 x 31 3/4 x 74 1/4	75 x 31 3/4 x 74 1/4	29 1/4 x 31 3/4 x 74 1/4	49 3/4 x 31 3/4 x 74 1/4	49 3/4 x 31 3/4 x 74 1/4	49 3/4 x 31 3/4 x 74 1/4

Model	ESWQ2D2 (Dual Temp)	ESGR1 (Refrigerator)	ESGR2 (Refrigerator)	ESGWR2 (Refrigerator)	ESGR3 (Refrigerator)
Capacity(Cu.Ft.)	39(R) 13(F)	23	48	55	71
Door	1(Full) 1(Hal) 2 (Drawer)	1 (Glass)	2 (Glass)	2 (Glass)	3 (Glass)
Shelves	5	3	6	6	9
Compressor (HP)	1/3(R) 1/2(F)	1/3	1/2	1/2	1/3+ x 2ea
Compressor Model	FFI10HAKW (R) NE2134GK (F)	FFI10HAKW	NE2134GK	NE2134GK	
Pressure of suction during operation cycle at setting temp	10 to 15 pounds	10 to 15 pounds	10 to 15 pounds	10 to 15 pounds	10 to 15 pounds
Power (V-Hz-Ph)	115-60-1	115-60-1	115-60-1	115-60-1	115-60-1
Temp. Range(F)	32~42(R) -4~32(F)	32 ~ 42	32 ~ 42	32 ~ 42	32 ~ 42
Refrigerant	R-134a(R) 404a(F)	R-134a	R-404a	R-404a	R-134a
Crated Weight(LBS)	573	311	434	478	585
Amps(A)	12.24	4.44	7.45	7.45	9.49
Ext. Dimensions (W x D x H inches)	59 x 31 3/4 x 74 1/4	29 1/4 x 31 3/4 x 74 1/4	49 3/4 x 31 3/4 x 74 1/4	59 x 31 3/4 x 74 1/4	75 x 31 3/4 x 74 1/4

[NOTE]

Ext. height does not include 5" overall height casters.
 Drawer pans are not include in Door & Drawer Combo Upright Reach-In units.
 R - Refrigerator F - Freezer

Specifications subject to change without notice.

CONTROL WIRING DIAGRAM ESR1, ESR1D2, ESGR1

115V X 60Hz X 1Ph

LEGEND

- LP: LIGHT LAMP
- RC: REFRIGERATOR COMPRESSOR
- FC: FREEZER COMPRESSOR
- CM: CONDENSER FAN MOTOR
- SC: START CAPACITOR
- SR: RELAY
- OL: OVERLOAD
- EH: ELECTRIC HEATER
- EM: EVAPORATOR FAN MOTOR
- OT: OVERHEAT TERMINATION
- TR: TRANSFORMER

COLOR

- B: BLUE
- P: PURPLE
- W: WHITE
- BR: BROWN
- BL: BLACK
- O: ORANGE
- Y: YELLOW
- R: RED
- G: GRAY

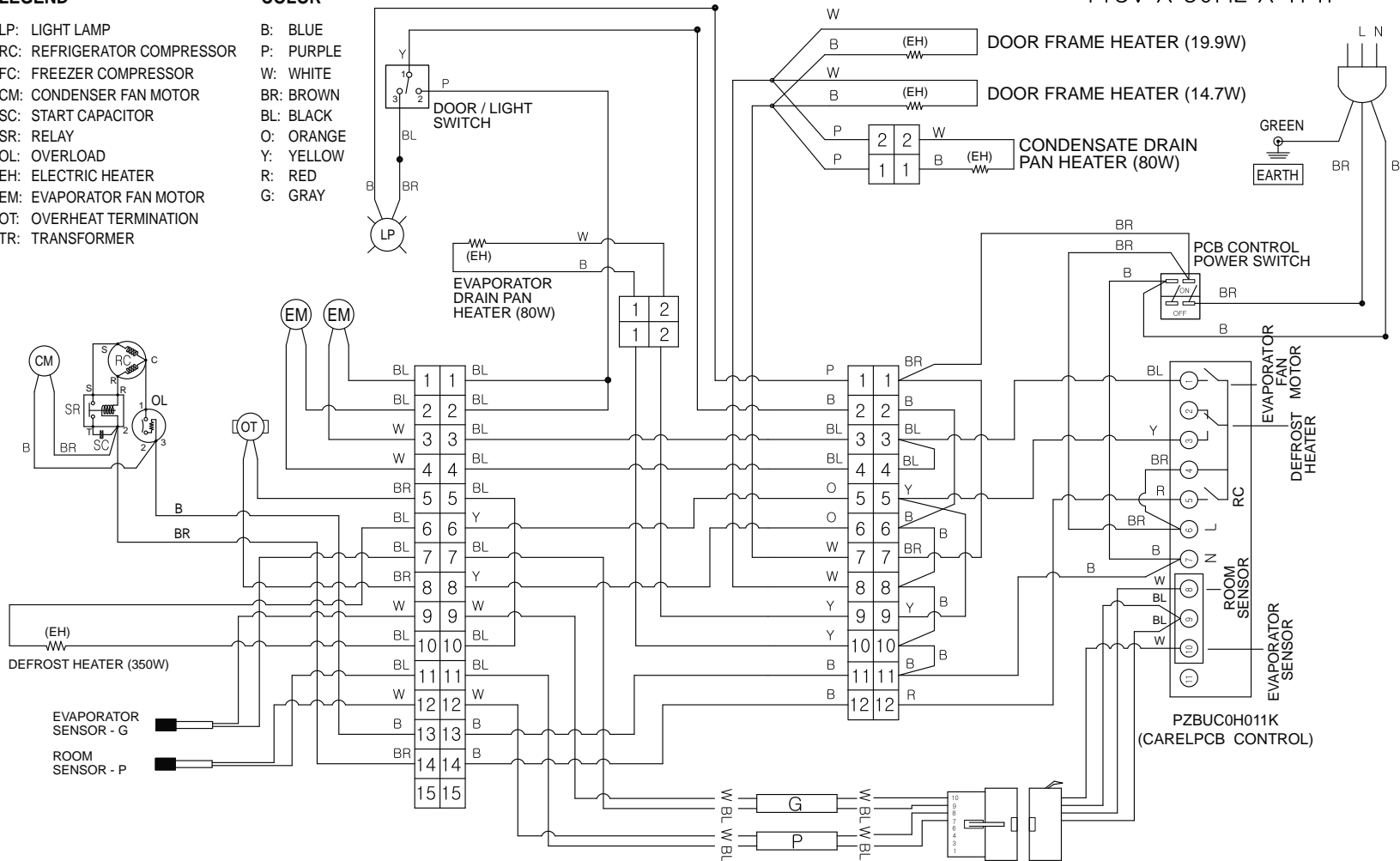

CONTROL WIRING DIAGRAM

ESF1

115V X 60Hz X 1Ph

LEGEND

- LP: LIGHT LAMP
- RC: REFRIGERATOR COMPRESSOR
- FC: FREEZER COMPRESSOR
- CM: CONDENSER FAN MOTOR
- SC: START CAPACITOR
- SR: RELAY
- OL: OVERLOAD
- EH: ELECTRIC HEATER
- EM: EVAPORATOR FAN MOTOR
- OT: OVERHEAT TERMINATION
- TR: TRANSFORMER

COLOR

- B: BLUE
- P: PURPLE
- W: WHITE
- BR: BROWN
- BL: BLACK
- O: ORANGE
- Y: YELLOW
- R: RED
- G: GRAY

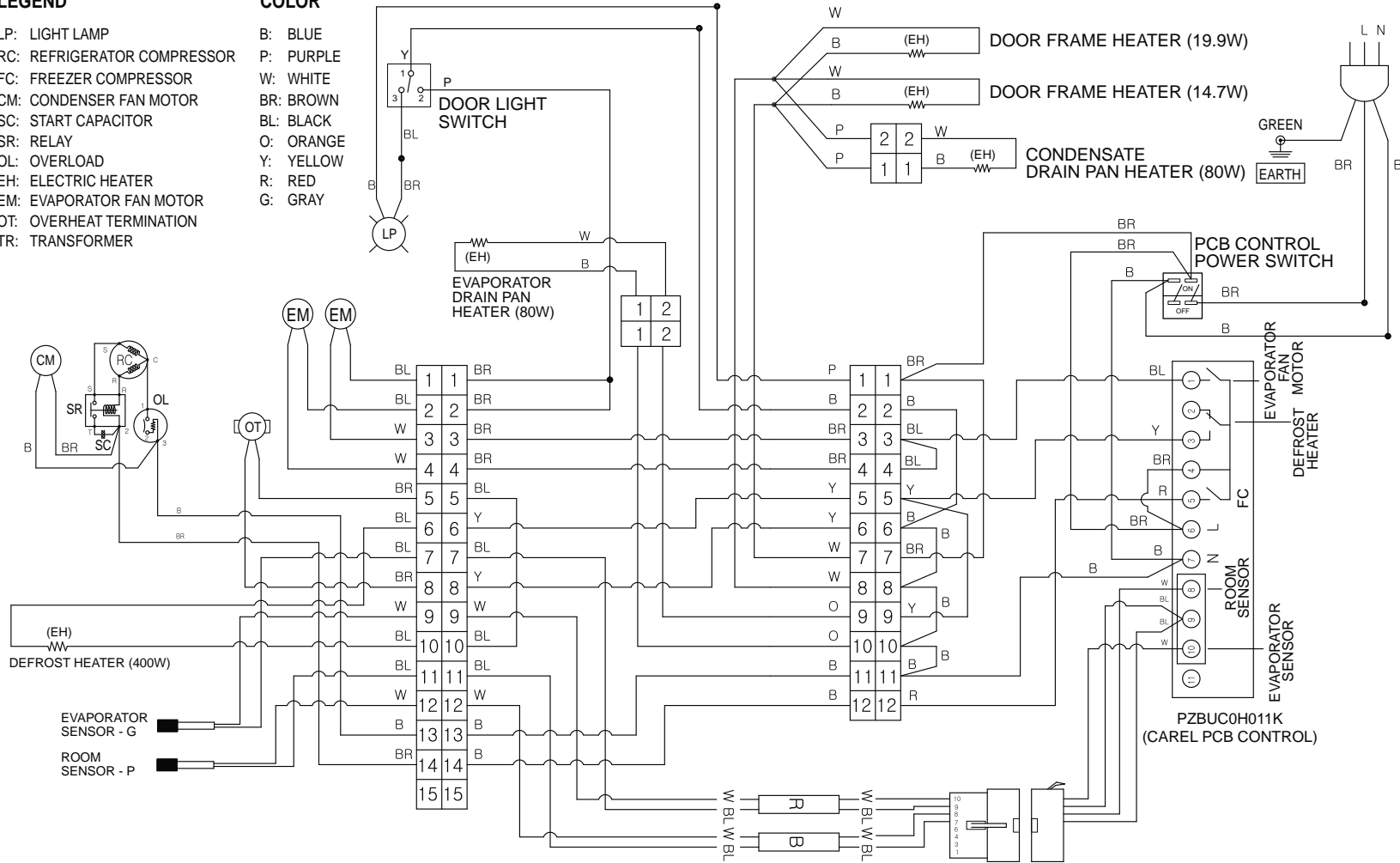

CONTROL WIRING DIAGRAM

ESF2, ESWF2

115V X 60Hz X 1Ph

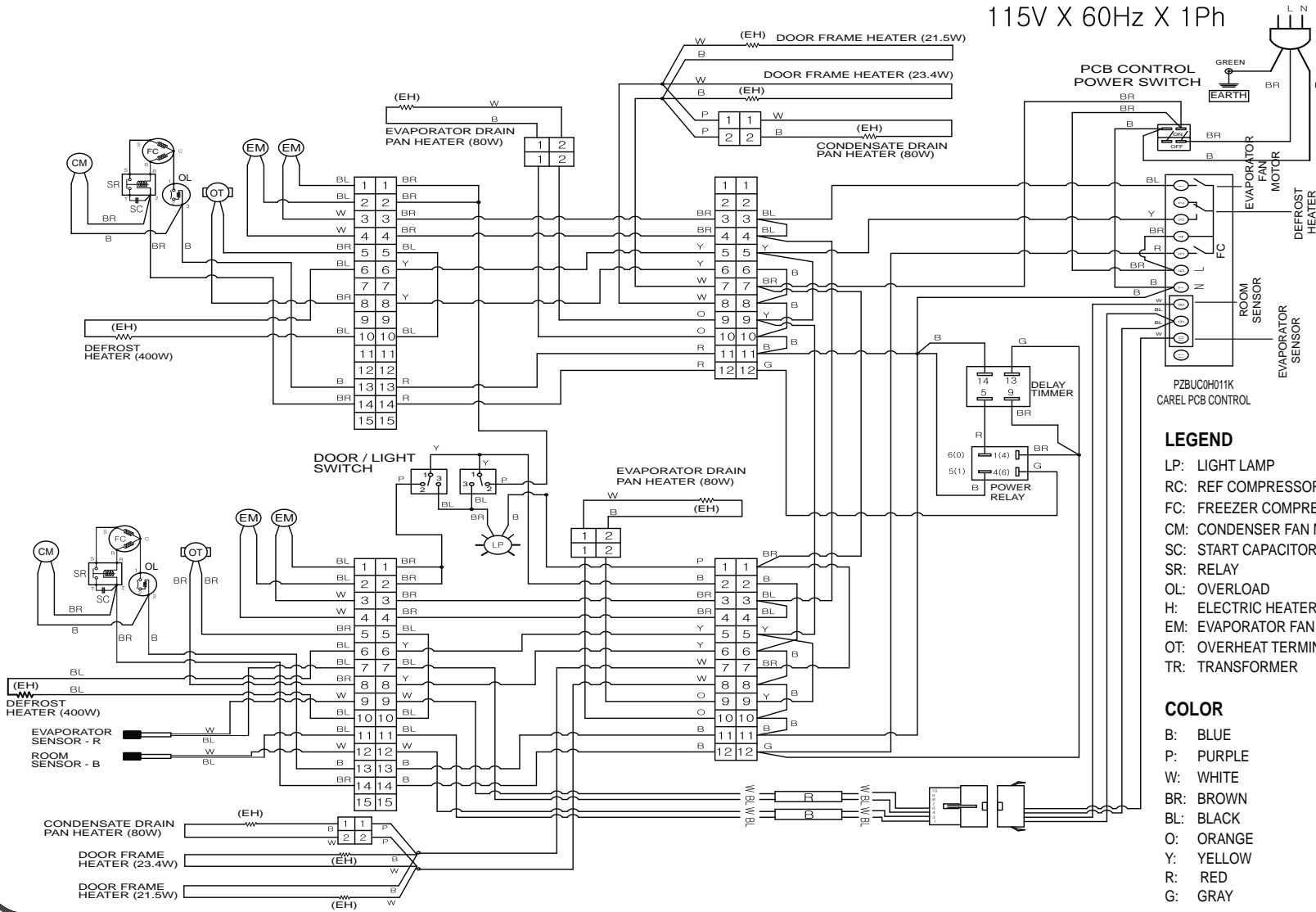

6. Wiring Diagrams – Continued

CONTROL WIRING DIAGRAM ESRF2, ESWRF2, ESRF3

115V X 60Hz X 1Ph

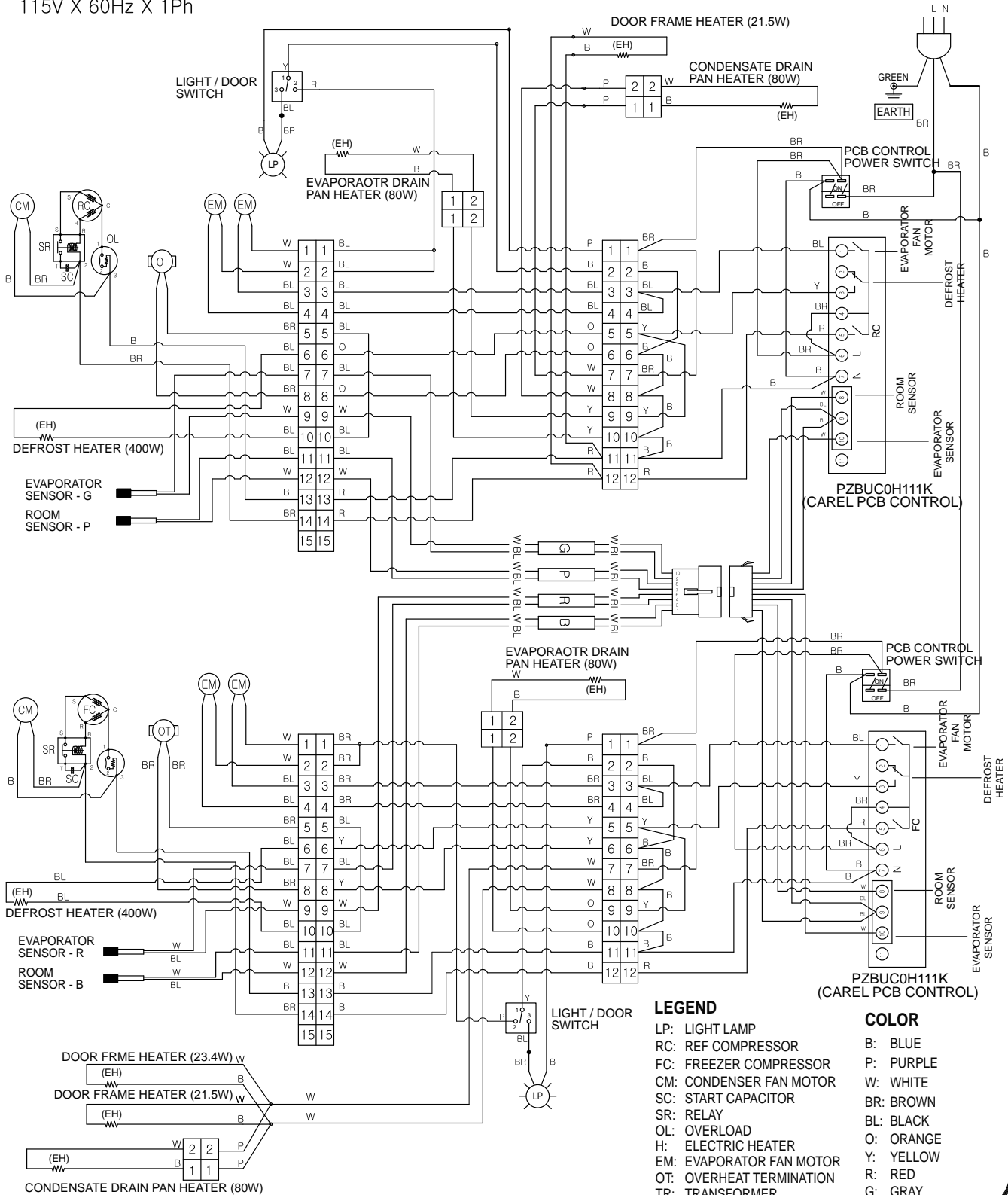

7. Electronic PCB Control

How to operate the controller

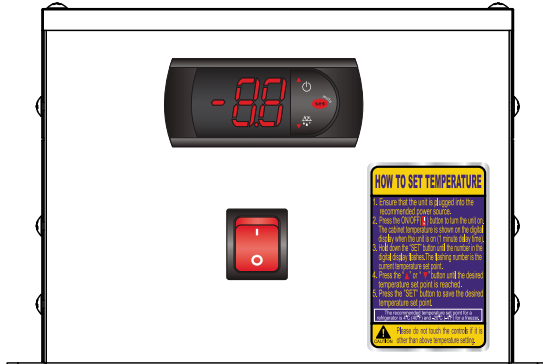

7.1 Display (User Interface)

The console is a typical 3-button CAREL display which regularly shows values from the operating sensor and alternately represents temperature and alarm codes once an alarm is generated.

7.2 Display LED Symbols.(Fig 7-1)

- ①, : ON if compressor output is ON.
- ②, : ON if evaporator fan is in operation.
- ③, : ON if manual and electric defrost is in operation.
- ④, : ON if temperature is displayed (-99 ~ 99℃).
- ⑤, : Alarm in progress.

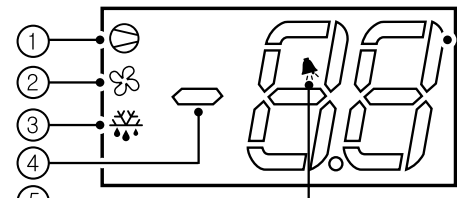

Fig 7-1

7.3 Button Symbols (Fig 7-2)

- ①,: Output ON/OFF if pressed for over 3 seconds.
- ②,: Changes operating values if pressed for 1 second.
Access parameter settings if pressed for over 3 seconds.
- ③,: Manual defrost ON/OFF if pressed for over 3 seconds.

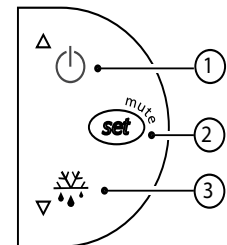

Fig 7-2

7.4 Checking and changing operating values.

To check operating values, press button for 1 second.
Preset values flickers.
Change the values by using buttons and press button.

7.5 Manual defrost ON/OFF

Defrost ON: press Down button for 3 seconds and longer.
Defrost OFF: press Down button for 3 seconds and longer while on defrost

7.6 Parameter Settings

Press key for over 3 seconds and it displays parameters and then displays [PS].
Move to the desired parameter code by using Up or Down keys and press .
Change a selected parameter by using Up or Down keys.
Press key to save the changed values.
To exit the menu, press key over 3 seconds.
(The present temperature is displayed)

7.7 Parameter setting (“C” parameter)

Hold down key for over 3 seconds so it displays parameters and then [PS]. Press again so it displays “00.” Enter “22” for the password and press . The first parameter “/2” is displayed.

Move to the desired parameter code by using Up or Down keys and press . Change a selected parameter by using Up or Down keys.

Press key to save the changed values. .

To exit the menu, hold down the key over 3 seconds. (The present temperature will be displayed)

7.8 Table of alarms and signals.

When an alarm is activated, the display shows the corresponding message that alternately flashes with the temperature. If fitted and enabled, the buzzer and the alarm relay are also activated.

All the alarms have automatic reset (that is, they stop when the cause of alarm is no longer present). The exception to this is alarm “CHt” which has a manual reset.

alarm code	buzzer and alarm relay	LED	alarm description
EO	active	ON	probe 1 error= control
E1	not active	ON	probe 2 error= defrost
LO	active	ON	low temperature alarm
HI	active	ON	high temperature alarm
EE	not active	ON	unit parameter error
dF	not active	OFF	defrost running

Table 7-1

7.9 Table of easy parameters

NOTES : "F" means that the parameters can be accessed without a password.

"C" means that the parameters are protected by a password.

Type "A" : Refrigerator compartment

Type "B" : Freezer compartment

Name	Description	Type " A "		Type " B "	
		Def	Vis.	Def	Vis.
Pw	Password	22	F	22	F
/2	/2 Probe measurement stability	15	C	15	C
/4	/4 Select probe display	1	C	1	C
/5	/5 Select u.d.m. probe °C / °F	1	C	1	C
/6	/6 Disable decimal point	1	C	1	C
/C1	/C1 Probe 1 offset	0	F	0	F
/C2	/C2 Probe 2 offset	0	F	0	F
/C3	/C3 Probe 3 offset	0	C	0	C
St	Set point	35	S	-4	S
rd	rd Control differential	4	F	4	F

7. Electronic PCB Control – Continued

r1	r1 Minimum set point value	32	C	-10	C
r2	r2 Maximum set point value	54	C	54	C
r3	r3 Select direct / reverse operation	0	C	0	C
r4	r4 Night-time set point delta	3	C	5.4	C
c0	c0 Compressor and fan start delay on power-up	1	C	1	C
c1	c1 Minimum time between consecutive compressor starts	0	C	0	C
c2	c2 Minimum compressor off time	0	C	0	C
c3	c3 Minimum compressor on time	0	C	0	C
c4	c4 Duty setting	0	C	0	C
cc	cc Continuous cycle duration	4	C	4	C
c6	c6 Temperature alarm bypass after continuous cycle	2	C	2	C
d0	d0 Type of Dfrost	0	C	2	C
dI	dI Interval between defrost	6	F	6	F
dt	dt End defrost temperature set point	60.8	C	60.8	C
dP	dP Maximum defrost duration ALARM ED	20	F	20	F
d4	d4 Defrost when switching the instrument on	0	C	0	C
d5	d5 Defrost delay on power-up	0	C	0	C
d6	d6 Freeze control temperature display during defrost	0	C	0	C
dd	dd Dripping time	2	C	2	C
d8	d8 Alarm bypass time after defrost	1	C	1	C
d9	d9 Defrost priority over compressor protectors	0	C	0	C
d/	d/ Defrost probe reading	-	F	-	F
dC	dC time base	0	C	0	C
A0	A0 Alarm and fan temperature differential	0	C	0	C
AL	AL Absolute/relative temperature for low temp. alarm	-50	C	-50	C
AH	AH Absolute/relative temperature for high temp. alarm	50	C	50	C
Ad	Ad Temperature alarm delay	0	C	0	C
A4	A4 3rd input configuration	0	C	0	C
A7	A7 Digital input alarm delay	0	C	0	C
A8	A8 Enable alarm ED(end defrost by timeout)	0	C	0	C
Ac	Ac Set point dirty condenser alarm	70	C	70	C
AE	AE Dirty condenser alarm differential temperature	5	C	5	C
AcD	AcD Dirty condensor alarm delay	0	C	0	C
F0	F0 Enable evaporator fan control	0	C	0	C
F1	F1 Evaporator fan control set point	5	C	5	C
F2	F2 Stop evaporator fan if compressor off	0	C	0	C
F3	F3 Evaporator fan status during defrost	1	C	1	C
Fd	Fd Post-dripping time	1	C	5	C
H0	H0 Serial address	1	C	1	C
H1	H1 AUX output configuration	0	C	0	C
H2	H2 Enable keypad	1	C	1	C
H5	H5 Detect changed parameters	1	C	1	C
EZY	Rapid parameter set selection	0	C	0	C

Table 7-2

8. Service Instructions

8.1 Control Box Assembly

Warning : Make sure that the power is disconnected before servicing the unit. Allow for sufficient working area to ensure your safety and the safety of the unit. Please note that grounding is necessary when reinstalling the unit after service.

8.1.1 How to Disassemble the Control Box Assembly

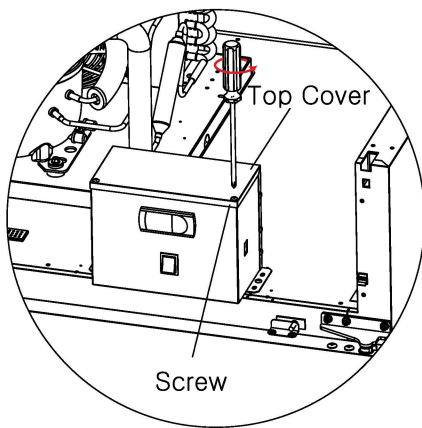
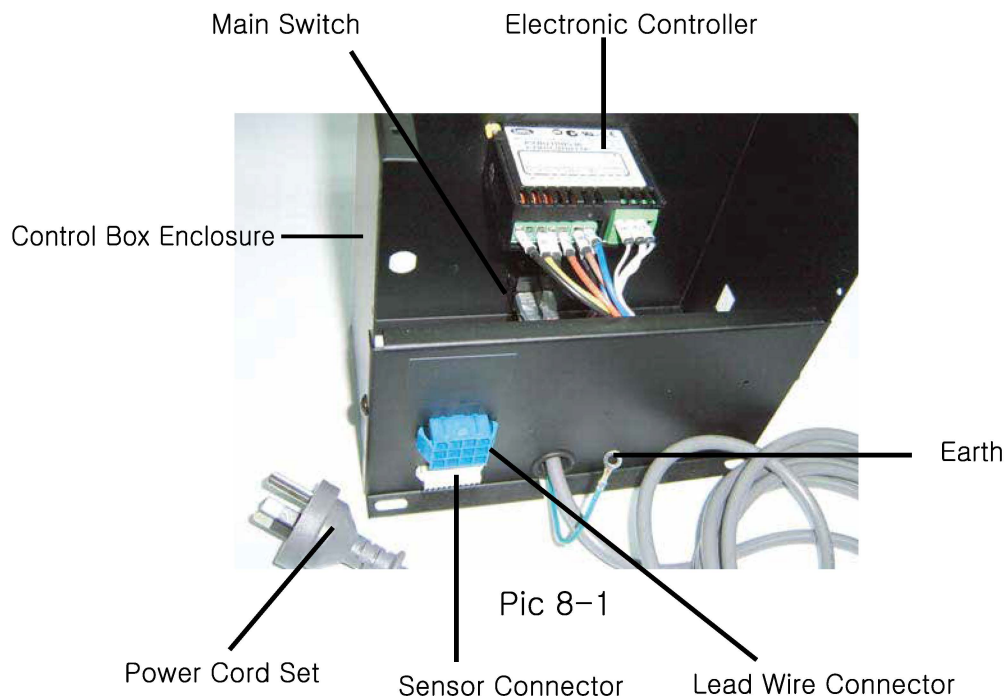
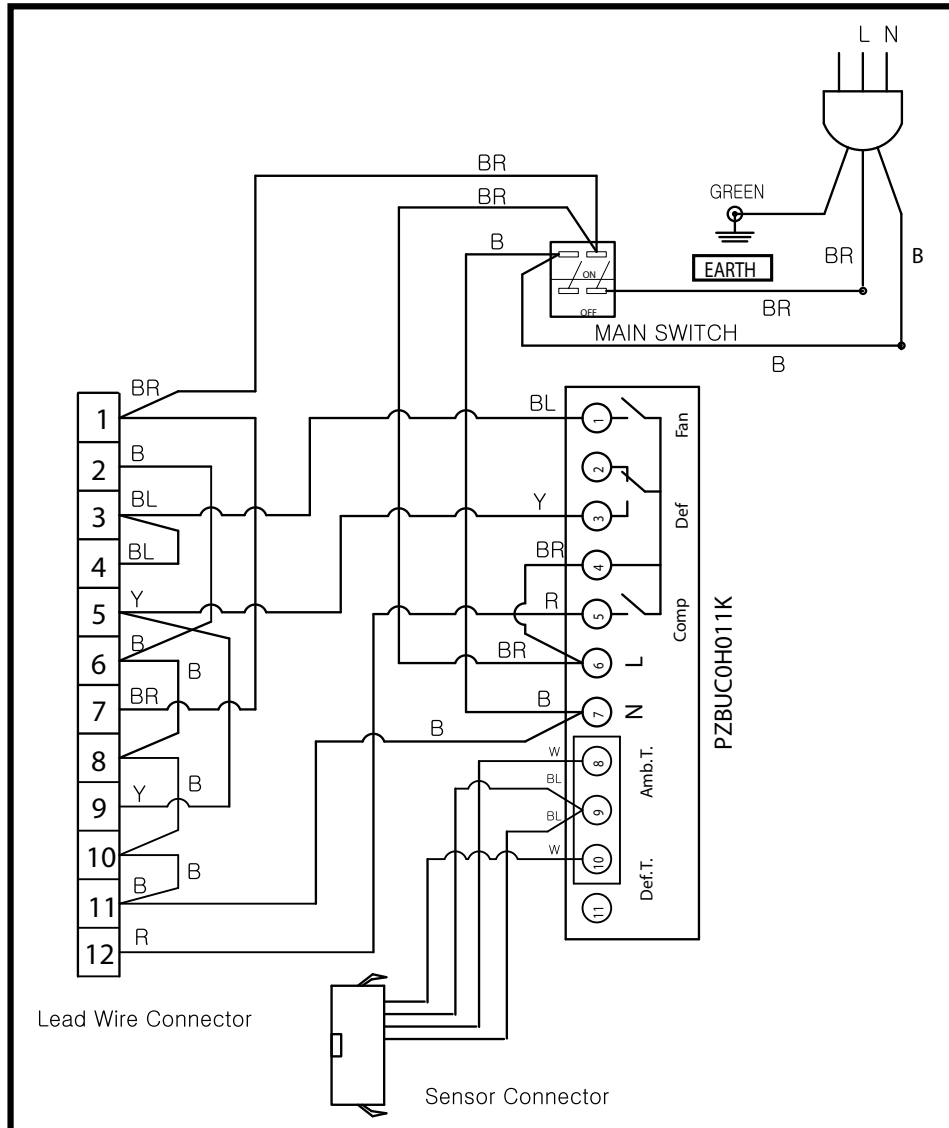

Fig 8-1

To access the control box interior, unscrew the 4 bolts located on the top cover housing. To replace the entire control box assembly, remove the main controller connector and sensor connector. Unbolt the screws fixing the control box housing to the condenser coil in the machine compartment. Also unbolt the screws fixing the ground wire and power cord set.





PCB Connection Wiring Diagram (Model: ESR2)

8. Service Instructions – Continued

8.1.2 Electronic Controller

Model	PZBUC0H011K
Power Supply (*)	230 Vac +10 /-15% 50/60 Hz;
Rated Power	3.5 VA
Inputs (*)	NTC probes 1 or 3 inputs. Digital input as alternative to third probe
Relay Outputs (*)	1.5HP relay on Pin -5 UL: 12 A Res. 10 FLA 60 LRA – 250 Vac
	8A relay on Pin -3 UL: 8 A Res. 2 FLA 12 LRA – 250 Vac C300, EN60730-1: 8(4) A NO, 6(4) A NC, 2(2) A CO – 250 Vac
	8A relay on Pin -1 UL: 8 A Res. 2 FLA 12 LRA – 250 Vac C300, EN60730-1: 8(4) A NO, 6(4) A NC, 2(2) A CO – 250 Vac
Type Of Probe (*)	Std CAREL NTC 10 K Ω at 25 °C
Connections (*)	screw terminals for cables with cross-sect. from 0.5 mm ² to 1.5 mm ² . Rated maximum current per terminal 12 A.
Assembly (*)	terminal: using screws from the front panel. Interface: wall
Display	3 digit LED display with sign (-199 to 999) and decimal point; six status LEDs
operating conditions	-10T50 °C – humidity <90% rH non-condensing
storage conditions	-20T70 °C – humidity <90% rH non-condensing
front panel index of protection	panel installation with IP65 gasket
case	plastic terminal, 81x36x65 mm
classification according to protection against electric shock	Class II when suitably integrated
environmental pollution	normal
PTI of the insulating material	250 V
period of stress across the insulating	long
category of resistance to heat and fire	category D (UL94 – V0)
immunity against voltage surges	category 1
type of action and disconnection	1C relay contacts
no. of relay automatic operating	EN60730-1:100,000 operations
software class and structure	Class A
cleaning the instrument	Only use neutral detergents and water.
cable max. length	serial: 1 km probes: 30 m relay: 10 m

Table 8-1

8. Service Instructions

8.1.3 How to the Remove Electronic Controller

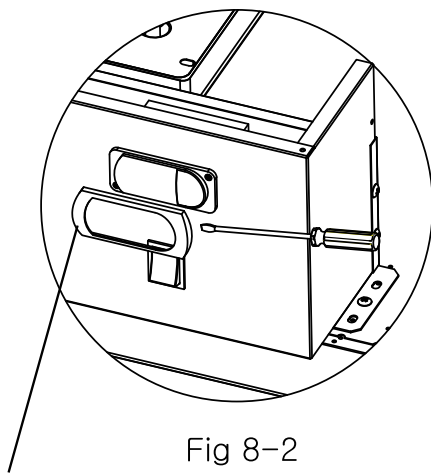

Fig 8-2

Controller Cover

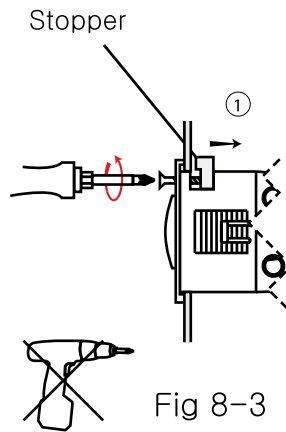

Fig 8-3

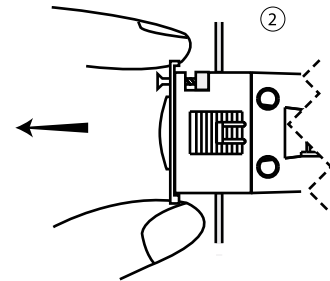

Fig 8-4

Remove the controller cover by using a blunt and flat tool as shown in the above figure (Fig 8-2) Use a (+) screwdriver to loosen the two screws on the controller until you have a small margin. (Fig 8-3). Remove the controller from the control box. Reassemble in the reverse order. (Fig 8-4)

8.1.4 Power Cord Set.

When replacing the power cord set, ensure that it is rated. Non-rated components may start fires and other accidents. To re-wire the power cord set, twist the same colored wires (natural + natural, live + live). Tighten using a close end connector. (Fig 8-5)

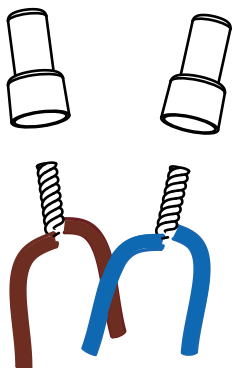
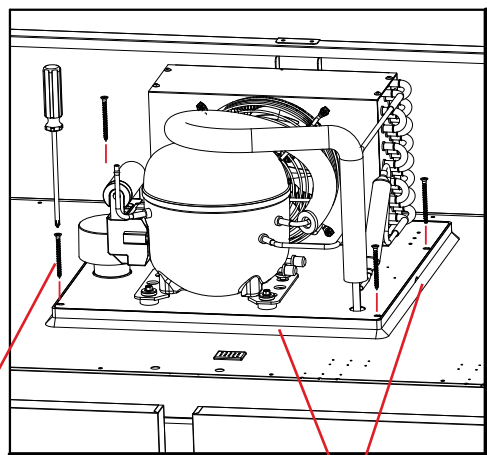

Fig 8-5

8.2 Condensing Unit Assembly.

Warning : Make sure that the power is disconnected before servicing.
Wait until condenser fan comes to a full stop. Due to the weight of the unit, have 2 or more people to assist.

8.2.1 How to Remove Condensing Unit Assembly



When replacing or servicing an integrated unit, remove the silicon sealant around the base. Loosen the 4 screws on the base and lift it up to detach. (Fig 8-6)

Fig 8-6
Condensing Unit Mounting Screw
Silicon Sealant

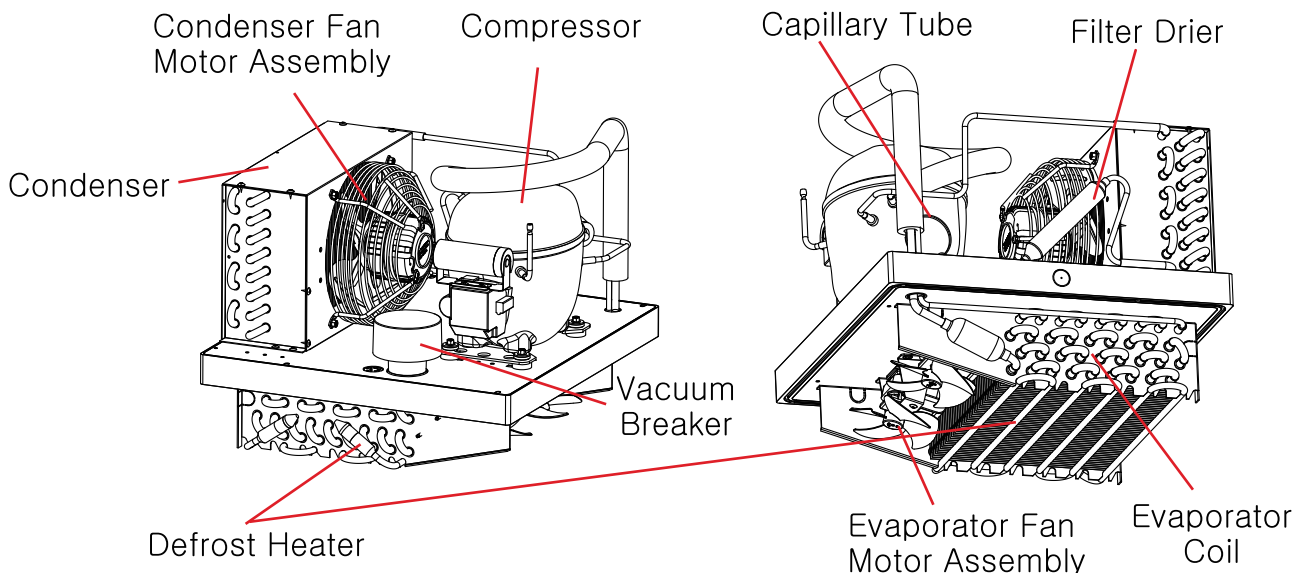
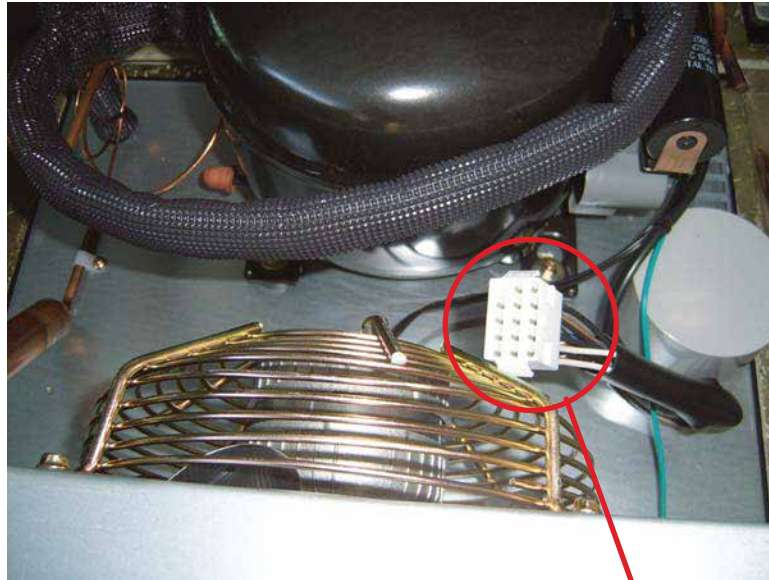
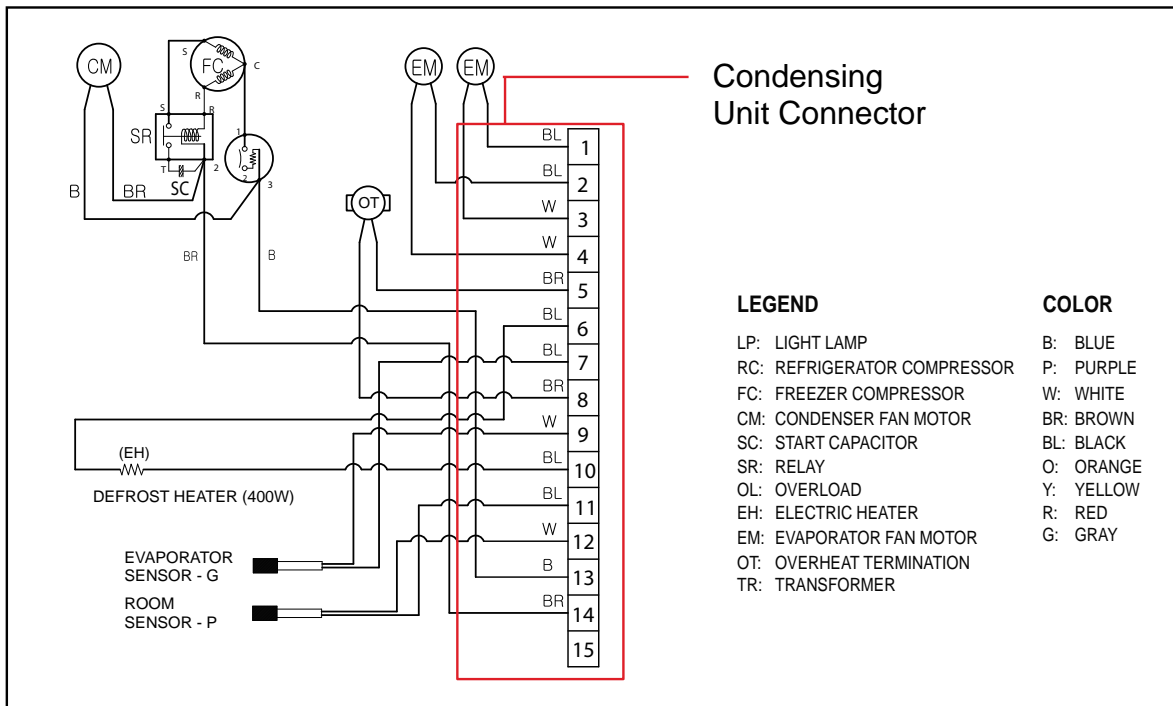

Fig 8-7



Pic 8-2

Condensing Unit Connector



Wiring Diagram (Model: [ESR2](#))

8.2.2 How to Remove the Compressor

1. Open compressor's electrical components housing and remove the lead wire coupled into the power motor and other parts. This is connected to the relay and overload protector (Fig 8-8-1 & 8-8-2).
2. Before removing the compressor, check the machine for remaining refrigerant.
3. To remove remaining refrigerant and balance internal pressure, cut the process tube.
4. Remove discharge tube and suction tube by using a gas burner.
5. Loosen the nuts on the compressor. (Fig 8-9)
6. Lift up the compressor to detach.

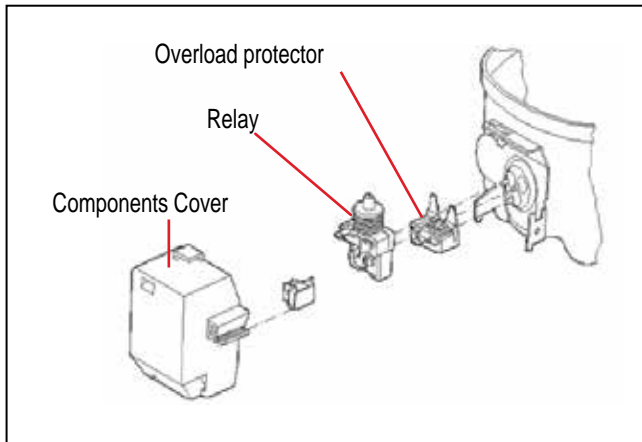

Fig 8-8-1 (Comp Model: FFI Compressor)

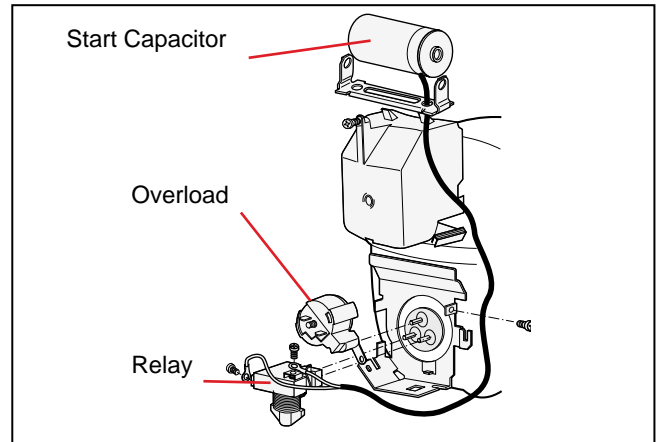

Fig 8-8-2 (Comp Model: NE2134GK)

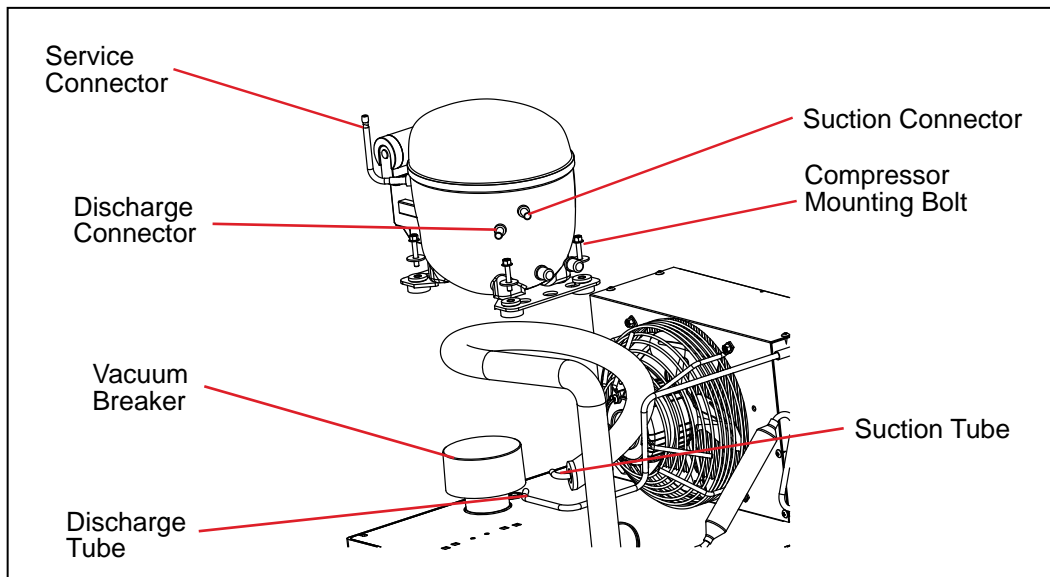

Fig 8-9

8. Service Instructions – Continued

8.2.3 Compressor Technical Data – Model: FFI-10HAKW.

(For compressors and quantity applicable to the models, refer to table 1.)

Model		FFI10-HAKW [1/3HP]						
Type		Hermetic reciprocating compressor						
Refrigerant		R-134a						
Nominal voltage and frequency		220-230 / 50-60 & 115 / 60					[Voltage / Hz]	
Application type		Low-Medium Back Pressure						
Evaporating temperature range		-35°C to -5 °C, -31F to 23 F						
Motor type		RSIR/CSIR						
Starting torque		LST – Low Starting Torque						
Expantion device		Capillary tube						
Maximum condensing pressures								
Operating (gauge)		16.2 [kgf/cm ²]			(230 psig)			
Peak (gauge)		20.6[kgf/cm ²]			(293 psig)			
Maximum winding temperature		130			[°C]			
Performance								
Cooling capacity			Power consumption	Current consumption	Gas flow rate	EFFICIENCY RATE		
[Btu/h]	[kcal/h]	[W]	[W]	[A]	[kg/h]	[Btu/Wh]	[Btu/Wh]	[W/W]
850	214	249	191	1.73	4.83	4.45	1.12	1.3
Start capacitor		53-64(230)				[μF(VAC minimum)]		
Motor protection (external)								
Code		4TM757KFBYY-53						
Opening Temperature		105°C (221°F)						
Closing Temperature		61°C (141.8°F)						
Tripping Current at 25°C (77°F)		9,8 A						
Reaction Time		5.0s – 15.0s						
Current Relay								
Pick Up Current (A)		6.8						
Drop-Out Current (A)		5.2						
EXTERNAL CHARACTERISTICS								
SUCTION		6.5				[mm]		
DISCHARGE		6.5				[mm]		
PROCESS		6.5				[mm]		

Table 8-2

8. Service Instructions – Continued

8.2.4 Compressor Technical Data – Model: NE2134GK

(For compressors and quantity applicable to the models, refer to table 1.)

Model	NE 2134GK [1/2HP]							
Type	Hermetic reciprocating compressor							
Refrigerant	R-404a							
Nominal voltage and frequency	220–240 / 50 & 115 / 60 [Voltage / Hz]							
Application type	Low–Medium Back Pressure							
Evaporating temperature range	–40°C to –10°C, –40F to 14F							
Motor type	CSIR							
Starting torque	LST – Low Starting Torque							
Expansion device	Capillary tube							
Maximum condensing pressures								
Operating (gauge)	25.7 [kgf/cm ²]				(365 psig)			
Peak (gauge)	28.7 [kgf/cm ²]				(408 psig)			
Maximum winding temperature	130				[°C]			
Performance								
Cooling capacity			Power consumption	Current consumption	Gas flow rate	EFFICIENCY RATE		
[Btu/h]	[kcal/h]	[W]	[W]	[A]	[kg/h]	[Btu/Wh]	[Btu/Wh]	[W/W]
1629	411	477	388	2.59	11.04	4.2	1.06	1.23
Start capacitor	53–64(230)				[μF (VAC minimum)]			
Motor protection (external)								
Code	T0546/G6							
Opening Temperature								
Closing Temperature								
Tripping Current at 25°C (77°F)								
Reaction Time								
Current Relay								
Pick Up Current (A)								
Drop–Out Current (A)								
EXTERNAL CHARACTERISTICS								
SUCTION	8.1				[mm]			
DISCHARGE	6.1				[mm]			
PROCESS	6.1				[mm]			

Table 8-3

8. Service Instructions – Continued

8.2.5 Compressor Troubleshooting

Compressor will not start – No hum.	Line disconnected. Starting relay open	Check the line and the starting relay contacts.
	Overload protector tripping.	Check the electrical connections.
	Thermostat not correctly adjusted.	Reset or replace the thermostat.
	Electrical connections improper or loose.	Check wiring against diagram, or tighten the connections.
Compressor will not start (hums) but trip on the overload protector.	Improperly wired.	Check wiring against diagram. Redo the electrical connections according to the electrical diagram.
	Low voltage at the compressor.	Determine reason and correct.
	Start capacitor defective.	Determine reason and replace the capacitor if necessary.
	Relay failing to close.	Determine reason and correct, replace the relay if necessary.
	Compressor motor has a winding open or shorted.	Replace the compressor.
	Internal mechanical problem in compressor.	Replace the compressor.
Compressor starts and runs, but short cycles on overload protector.	Additional current passing through overload protector.	Check wiring diagram. Check for added fan motors, pump, etc. connected to the wrong side of protector.
	Low voltage at compressor (or unbalanced if three phase).	Determine reason and correct.
	Overload protector defective.	Check current, replace protector.
	Run capacitor defective.	Determine reason and replace.
	Excessively high discharge pressure.	Check ventilation, restrictions in cooling medium, restriction in refrigeration system.
	Excessively high suction pressure.	Check for possibility of incorrect application. Use stronger unit.
	Compressor too hot. Return gas hot.	Check refrigerant charge, repair leaks, and add gas if necessary.
	Compressor motor has a winding shorted	Replace the compressor.
Compressor starts, but does not switch off of start winding.	Improperly wired.	Check wiring against diagram.
	Low voltage at the compressor.	Determine reason and correct.
	Run capacitor defective.	Determine reason and replace.
	Relay failing to open.	Determine reason and correct, replace if necessary.
	Excessively high discharge pressure.	Check discharge shut-off valve, possible overcharge, or insufficient cooling at condenser.
	Compressor motor has a winding open or shorted.	Replace the compressor.
	Internal mechanical problem in compressor (tight).	Replace the compressor.

Table 8-4

8.2.6 Condenser Fan Motor Assembly

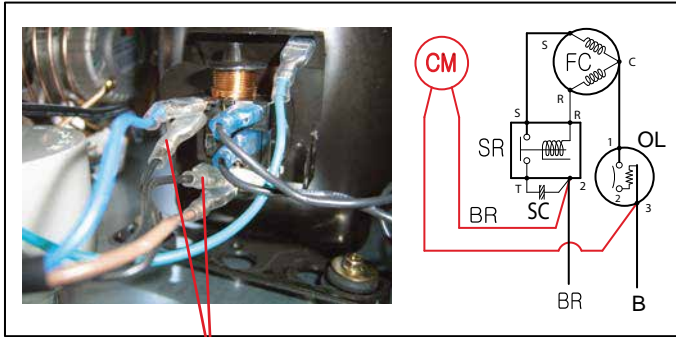

Motor Wire & Terminal

Pic 8-3

1. Open the electrical component cover of the compressor to remove the motor terminal. (Pic 8-3)

CM: Condensing Motor
 SR: Relay
 SC: Start Capacitor
 OL: Overload
 FC: Freezer Compressor
 BR: Brown
 B: Blue

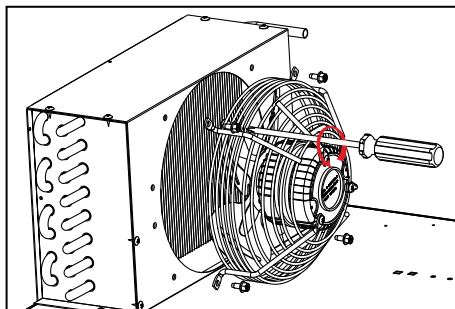

Fig 8-10

2. Unscrew the bolts of the fan motor assembly from the condenser coil. (Fig 8-10)

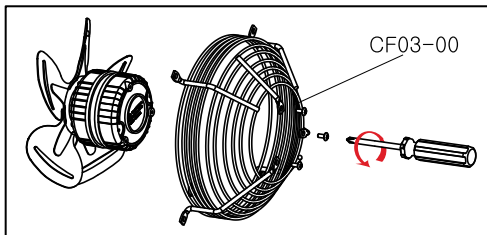

Fig 8-11

3. Unscrew the connecting bolts between the fan motor and fan guard. (Fig 8-11)

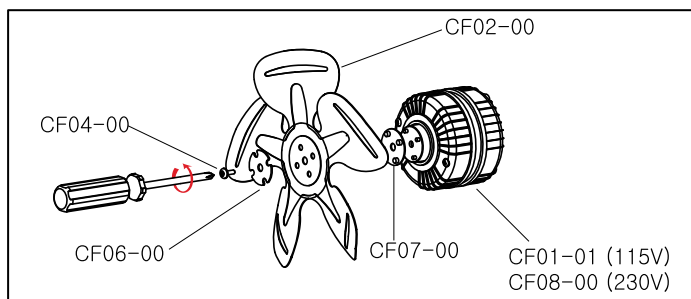

Fig 8-12

4. To remove the fan blade, unscrew the bolt attaching the blade onto the motor shaft. (Fig 8-12)

8.2.7 Evaporator Fan Motor and Defrost Overheat Termination Backup Switch

Warning : Make sure that the power is disconnected before servicing. Allow for sufficient working space to ensure your safety and the safety of the unit.

EH: ELECTRIC HEATER B: BLUE BR: BROWN
 EM: EVAPORATOR FAN MOTOR P: PURPLE BL: BLACK
 OT: OVERHEAT TERMINATION W: WHITE G: GRAY

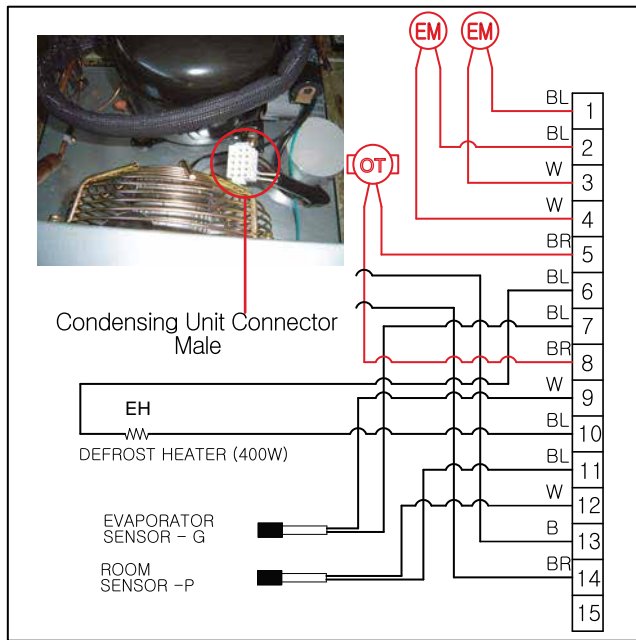

Pic 8-4

1. To remove evaporator fan motor and DTBS, detach the evaporator fan motor and DTBS terminal from the connector located in the condensing unit. (Pic 8-4)
2. Take off the evaporator cover. (Pic 8-4)
3. Pull out the fan blades from the motor. (Fig 8-13)
4. Remove the screws holding the motor in place. (Fig 8-14)
5. Remove the screws on the DTBS and install new parts. (Fig 8-15)

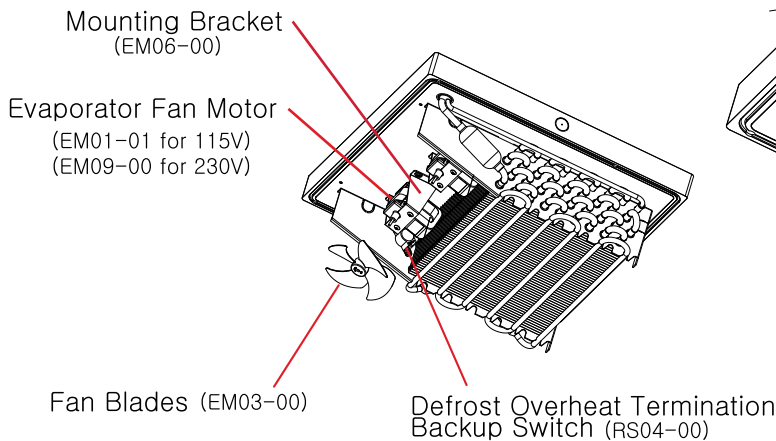

Fig 8-13

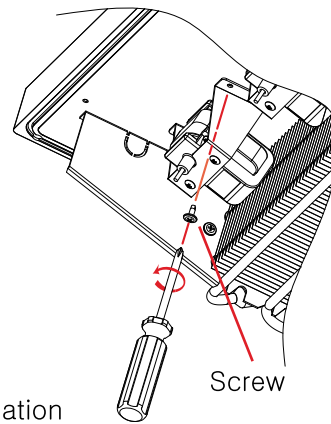

Fig 8-14

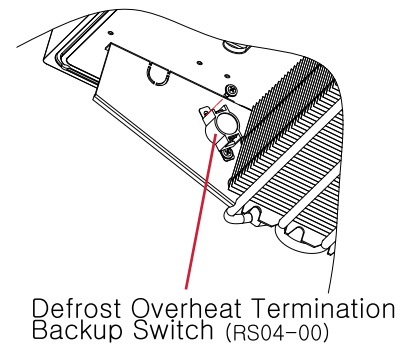
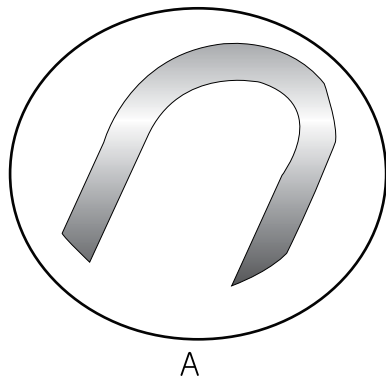
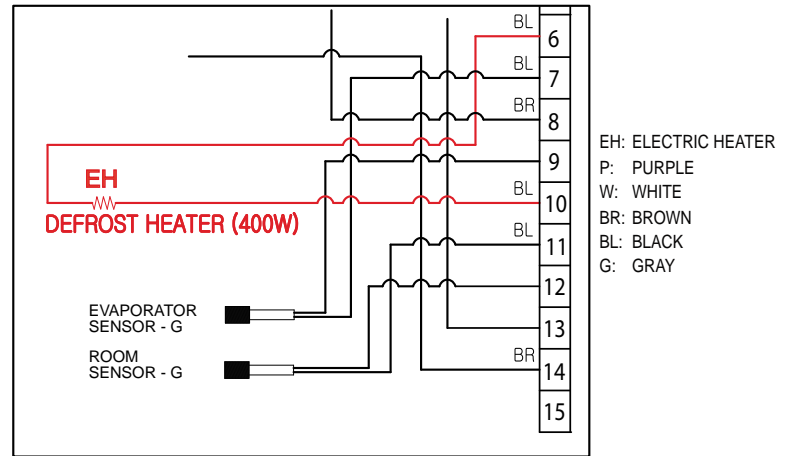
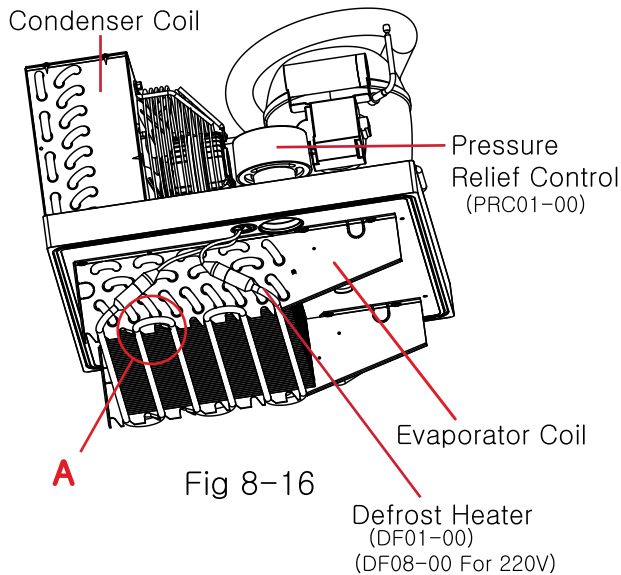

Fig 8-15

8.2.8 Defrost Heater

Warning : Make sure that the power is disconnected before servicing. Allow for sufficient working space to ensure your safety and the safety of the unit.



1. To remove the defrost heater, detach the defrost heater terminal from the connector located in the condensing unit. (Pic 8-4)
2. To repair the defrost heater, spread the bent tube sheet blade using appropriate tools. (Fig 8-18)
3. Carefully separate the heater from the evaporator. (Fig 8-19)
4. Replace it with the new part.

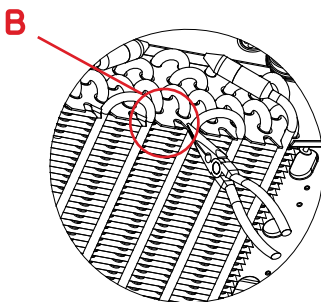
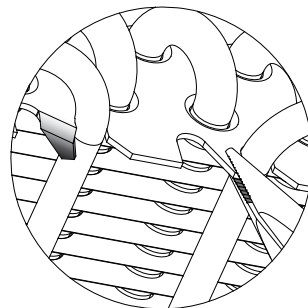

Fig 8-18



B

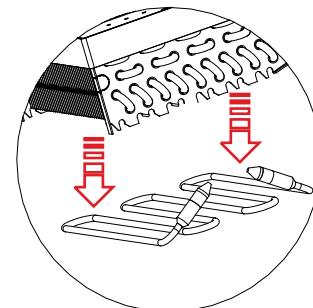
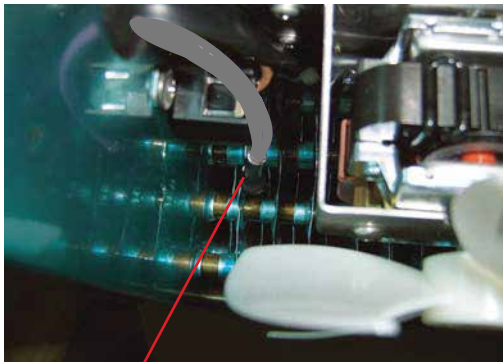

Fig 8-19

8.2.9 Evaporator Sensor

Warning : Make sure that the power is disconnected before servicing. Allow for sufficient working space to ensure your safety and the safety of the unit.



Pic 8-5

Evaporator Coil Sensor (RS02-00)

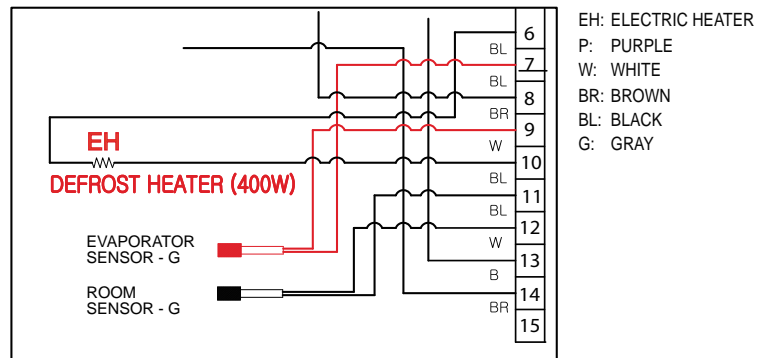

Wiring Diagram

1. Take off the evaporator drain cover. (8.4)
2. Locate the sensor between the evaporator coil fins as seen in the above figure. (Pic-8-5)
3. To remove the overheat protector, detach its terminal from the condensing unit connector. (Pic 8-4)
4. Replace it the new part.
5. Reassemble in the reverse order.

8.3 Interior Light and Switch

8.3.1 Light Bulb Cover

Warning : Make sure the power is disconnected before servicing to ensure your safety and the safety of the unit.

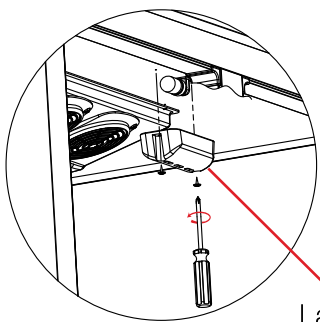

Lamp Protection Plastic Cover (SS13-00)

Fig 8-20

1. Unscrew the bolts fixing the light bulb cover to the ceiling. (Fig 8-20)
2. Replace it with the new cover.

8.3.2 Light Bulb Socket

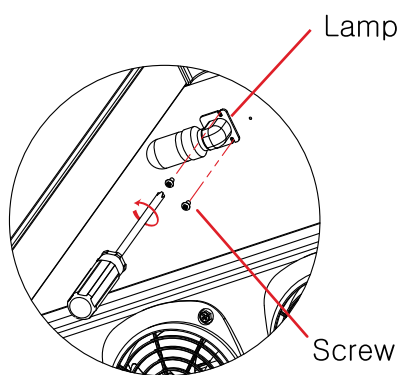

Lamp (SS11-00) and Socket (SS12-00)

Screw

Fig 8-21

1. Unscrew the bolts fixing the light bulb cover to the ceiling. (Fig 8-20)
2. Unbolt the screws fixing the socket. (Fig 8- 21)

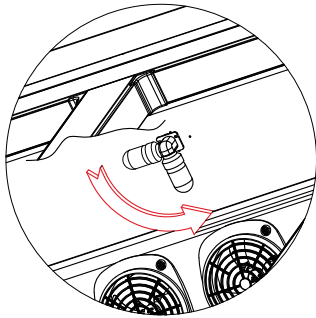
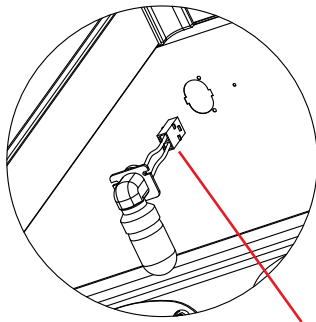

Fig 8-22

3. Turn the socket about 90 degrees. (Fig 8-22)
(Remove before servicing to avoid damaging the bulb)

4. Take the socket and remove the wire and connector from the wall. (Fig 8-23)
(It is recommended that you use a tool for this due to the sharp steel plate around the hole.)



Connector

Fig 8-23

5. Separate the connector.

6. Replace it with a new one.

7. Reassemble in the reverse order.

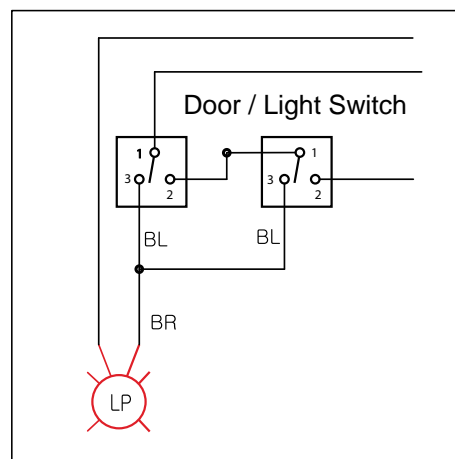

LP: LIGHT LAMP
BR: BROWN
BL: BLACK

Wiring Diagram
(Model: **ESR2**)

8.3.3 Door / Light Switch

WARNING : Make sure that the power is disconnected before servicing.
Allow for sufficient working space to ensure your safety and the safety of the unit.

1. Check the switches for repair. (Fig 8-24)

(Open the both doors and press the switches to check operation. When they are pressed, evaporator fan motors should run and interior light should be on.)

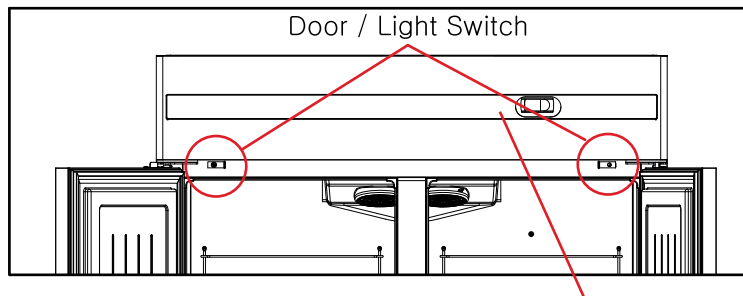

Fig 8-24

Front Top Grill (SGR02-00)

2. Detach the top front grill and keep the doors open.

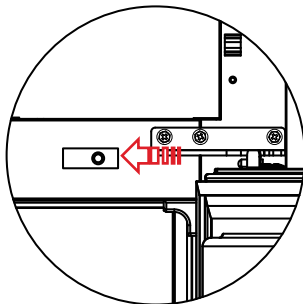

Fig 8-25

3. While applying pressure on the door switch, push it towards the center of the unit or left as indicated. (Fig 8-25)

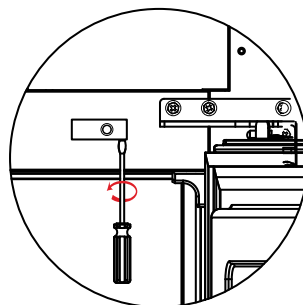

Fig 8-26

4. Lift up the corner of the switch using appropriate tools. (Fig 8-26)

5. Completely pull out the switches by using a switch bead tool. (Fig 8-27)

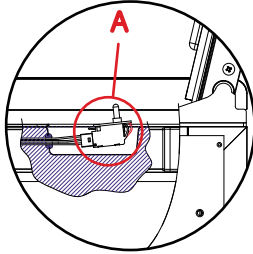
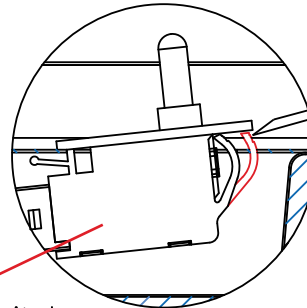
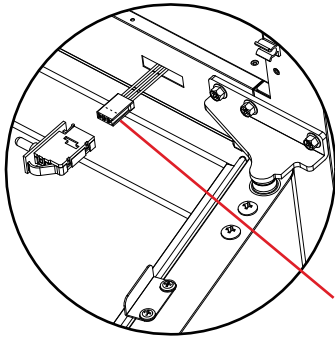

Fig 8-27



Door / Light Switch
(SS19-00)

A



Connector

Fig 8-28

6. Carefully pull out the switch so that connectors and lead wires in the switch box are not damaged. (Fig 8-28)

(Because of the sharp steel plate, it is recommended that you use a tool.)

7. Completely remove the connector.

8. Replace it with a new switch and reassemble in the reverse order.

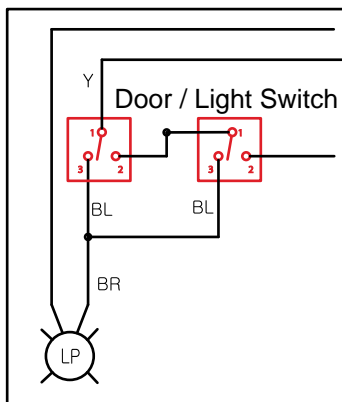

Wiring Diagram
(Model: **ESR2**)

LP: LIGHT LAMP
BR: BROWN
BL: BLACK

8.4 Evaporator Drain Cover Assembly

WARNING : Make sure that the power is disconnected before servicing. Allow for sufficient working space to ensure your safety and the safety of the unit.

1. Detach the drain pan connector terminal in the condensing unit. (Pic 8-6)

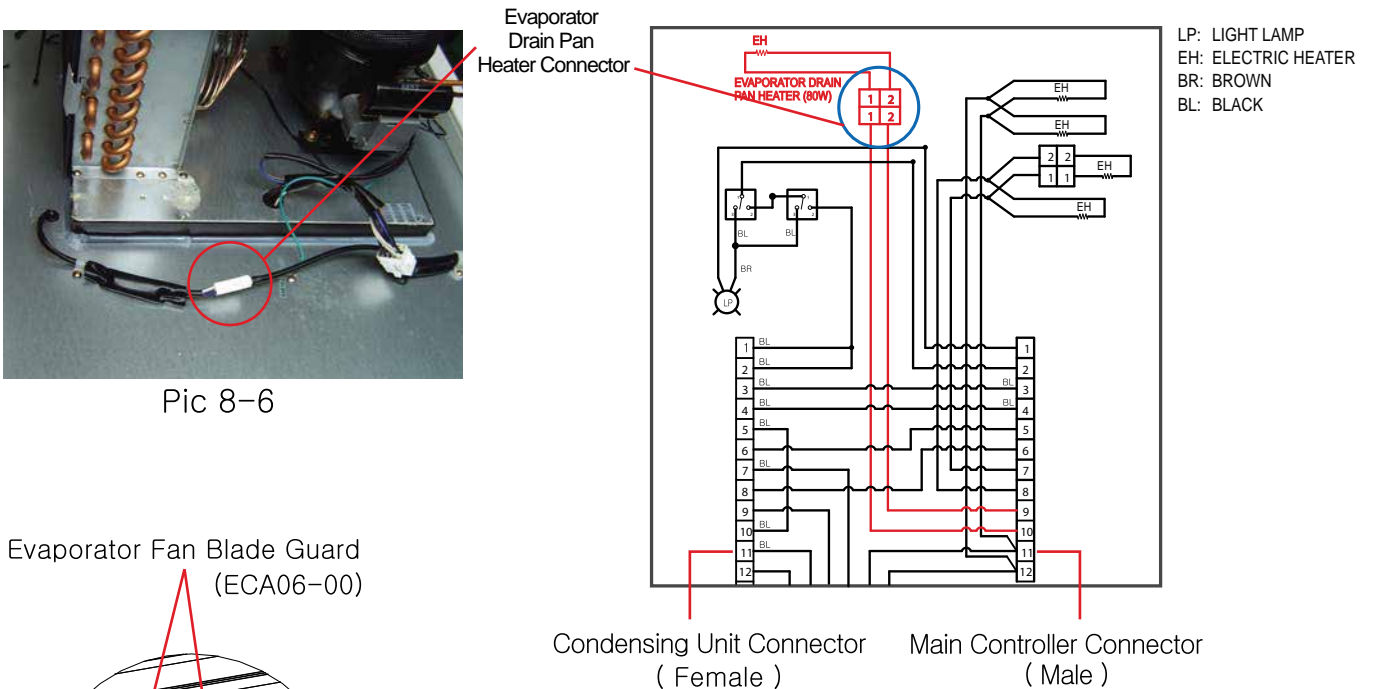

Pic 8-6

Evaporator Fan Blade Guard (ECA06-00)

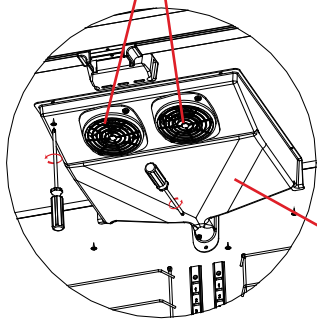

Fig 8-29

2. Remove the 5 screws fixing the evaporator cover assembly to the cabinet ceiling. (Fig 8-29)

Evaporator Drain Cover Assembly (ECA02-02)
(ECA07-00 For 220V)

3. Repair or replace the evaporator cover assembly. Refer to the disassembly manual of the evaporator cover assembly.

4. Reassemble in the reverse order.

8.4.1 Evaporator Drain Pan Heater

1. Detach the evaporator cover assembly in accordance with the procedure described in 8.4.

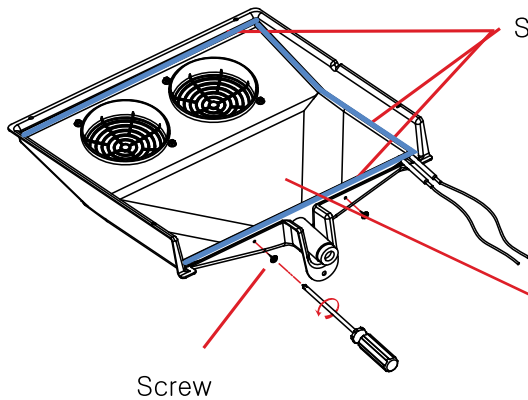
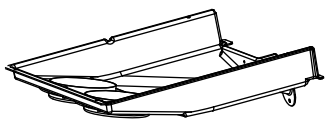

Fig 8-30

2. Loosen and remove two screws. (Fig 8-30)
3. Remove the marked silicone sealant. (Fig 8-30)



Drain Pan Cover



Drain Pan

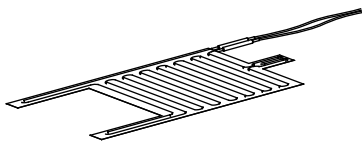

Drain Pan Heater



Insulation

Fig 8-31

4. Separate the drain pan from the cover.
5. Remove the insulation from the rear of the drain pan.
6. Remove the drain pan heater with the silver foil sheet attachment.
7. Remove the protective sheet of the new drain pan heater and uniformly spread it onto the bottom. (Fig 8-32)
8. Reassemble in the reverse order.

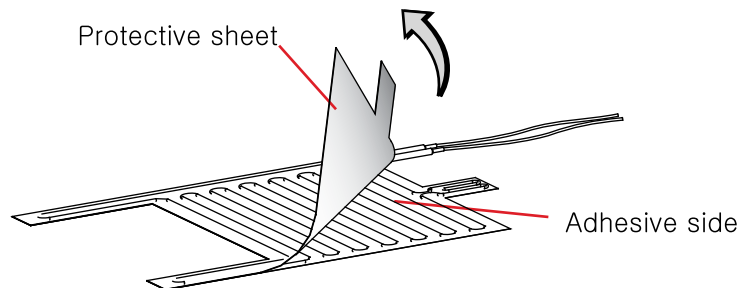

Fig 8-32

IMPORTANT : During reassembly, ensure that it is air tight by using silicone sealant.

8.5 Condensate Drain Pan Heater Assembly

WARNING : Make sure that the power is disconnected before servicing. Allow for sufficient working space to ensure your safety and the safety of the unit.

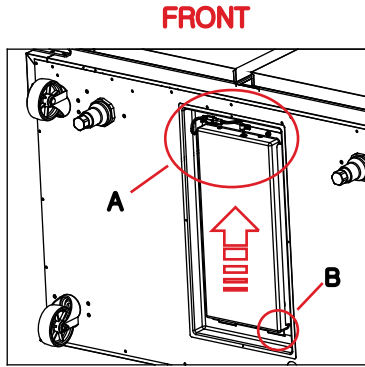
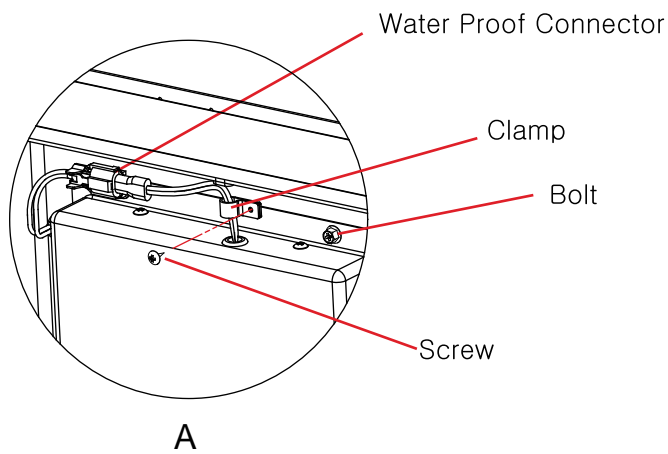
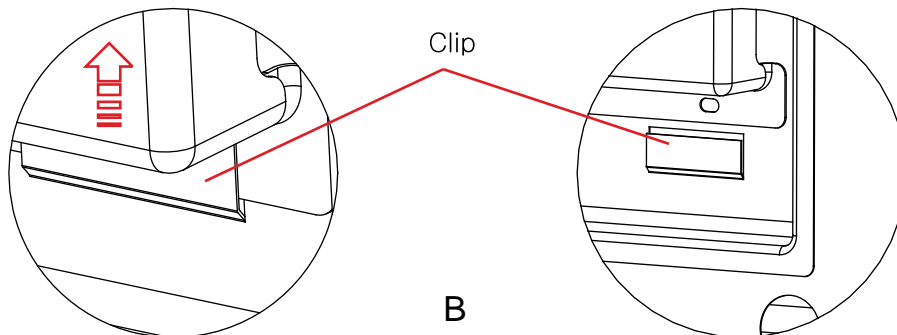

Fig 8-33

1. Detach the connector.
2. Loosen the screws to remove the clamp fixing the lead wire on the front.
3. Drain box assembly is fixed with two bolts and two clips.
4. Loosen the two bolts on the front.



5. Pull out the drain box assembly from the front along the direction of the arrow so that the rear is aligned with the clip.
6. Replace with the new drain box assembly.
7. Reassemble it in reverse order.



8.5.1 Condensate Pan Heater

WARNING : Make sure that the power is disconnected before servicing. Allow for sufficient working space to ensure your safety and the safety of the unit.

Condensate Drain Pan Heater Assembly (DRA01-00)

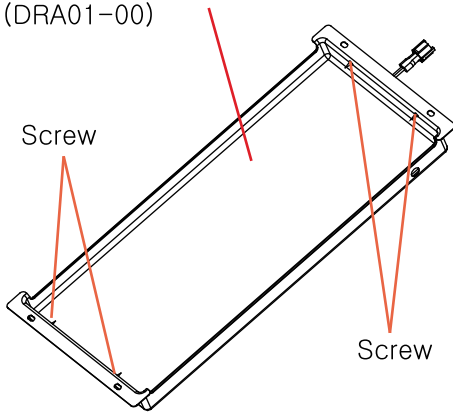

Fig 8-34

1. Follow the procedure described in 7.4.
2. Unbolt the 4 screws clamping the two cases together. (Fig 8-34)
3. Separate the terminal from the connector.
4. Loosen the two bolts at the front.
5. Separate the overlapped drain box A from the bottom case B.
6. Detach the drain box heater with the adhesive sheet located at the bottom of drain box A.
7. Remove the protective sheet of the new drain box heater and uniformly spread it onto the bottom of drain box A.
8. Reassemble in the reverse order.

Case(Top Part)- Box A (DRA01-01)

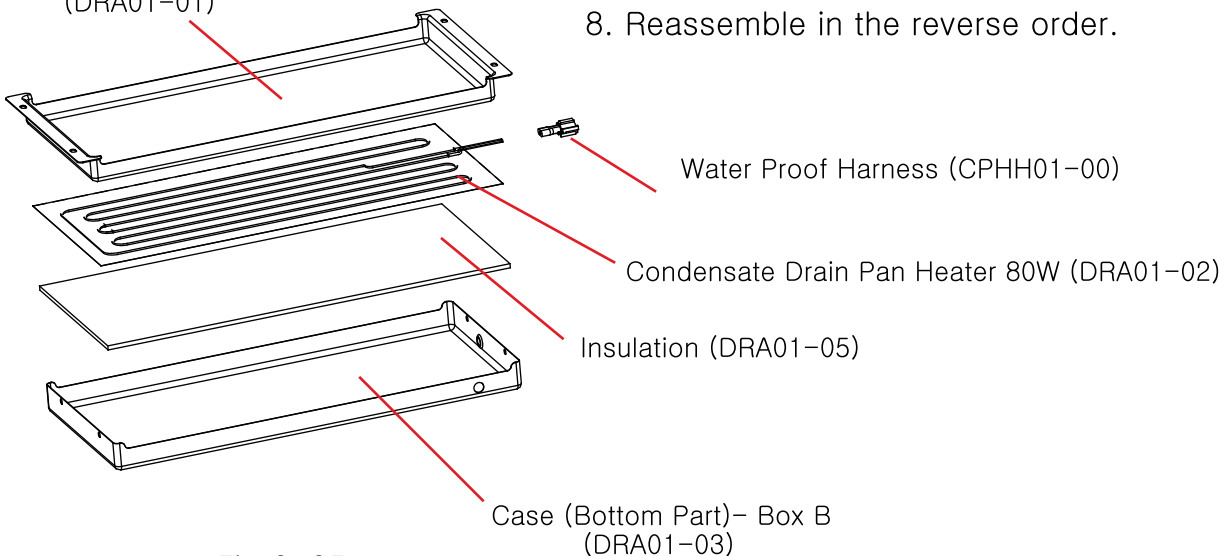
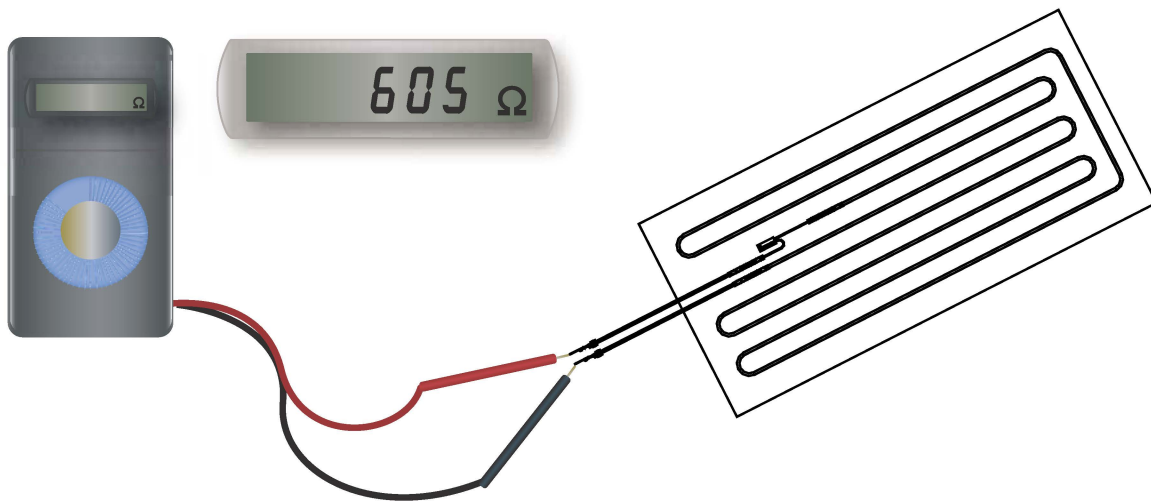

Fig 8-35

8.6 How to Check the Heater

1. Locate the heater connector to check operation.
2. After removing the connector, connect the tester probes to both ends of the terminal where the heater is connected.
3. Read the resistance on the tester.
4. Refer to Table 8–5. It is considered normal if the resistance is $\pm 5\%$.
5. Refer to Figure 8–36 for the location of door side heater and door sub heater.



(Example : Condensate Drain Pan Heater)

	Power Consumption	Resistance	Model
Door Side Frame Heater	14.7 W (L)	3.292kΩ	ESR1,ESF1,ESRH2,ESFH2,ESGR1,ESR1D2
	19.9 W (R)	2.432kΩ	
	21.5 W	2.251kΩ	ESR(W)2,ESF(W)2,ES(W)RF2,ESGR2,ESR3 ESRF3,ESGR3,ESF3
Door Middle Frame Heater	23.4 W	2.068kΩ	ESR(W)2,ESF(W)2,ES(W)RF2,ESGR2,ESR3 ESRF3,ESGR3,ESF3
Condensate Pan Heater	80 W	605Ω	Common
Evap Drain Pan Heater	80 W	605Ω	Common
Defrost Heater	350 W	138Ω	Upright Reach-In Refrigerators
Defrost Heater	400 W	121Ω	Upright Reach-In Freezers

Table 8–5

8. Service Instructions – Continued

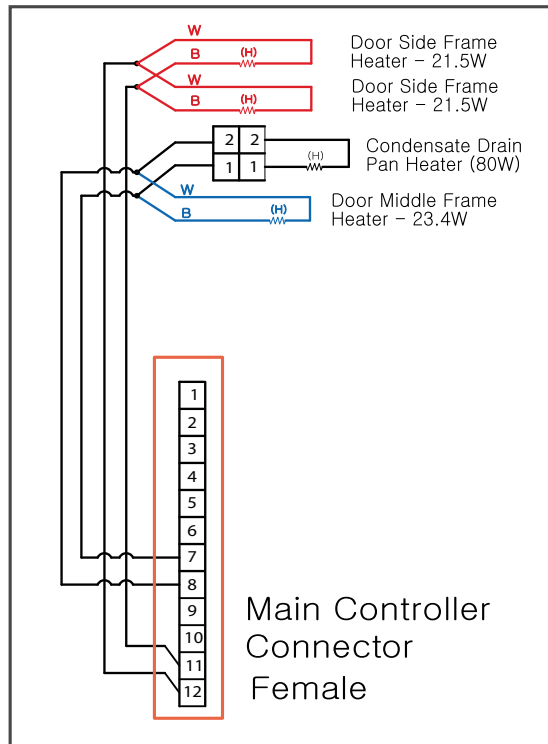
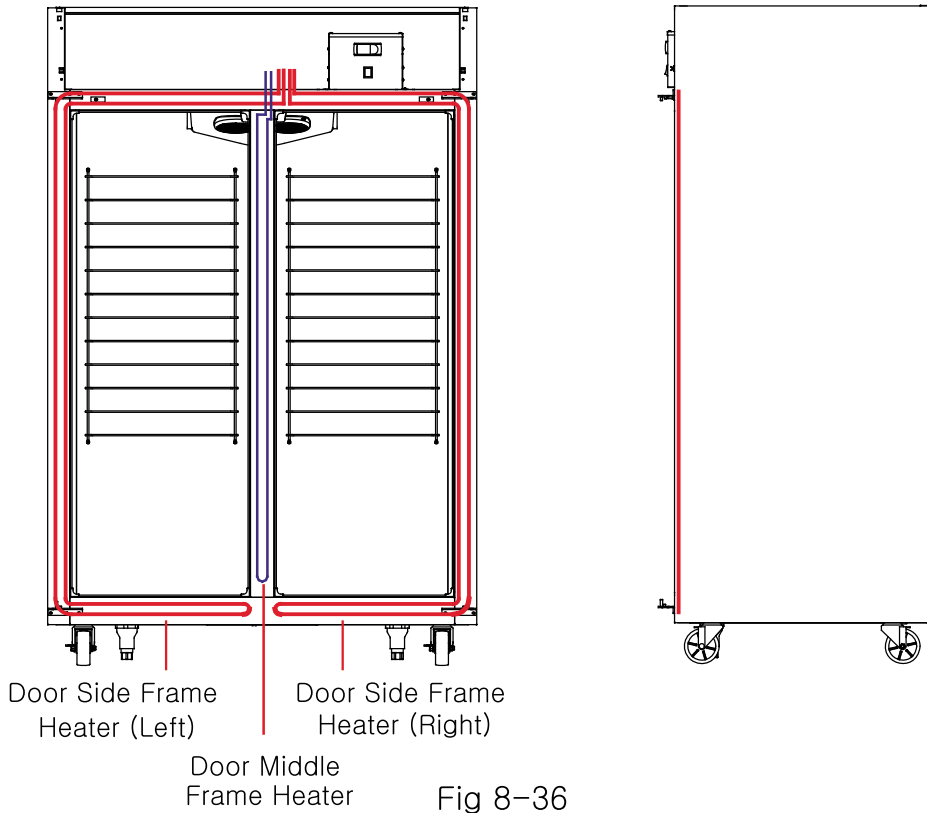

8.7 Door

8.7.1 How to Remove the Door Assembly

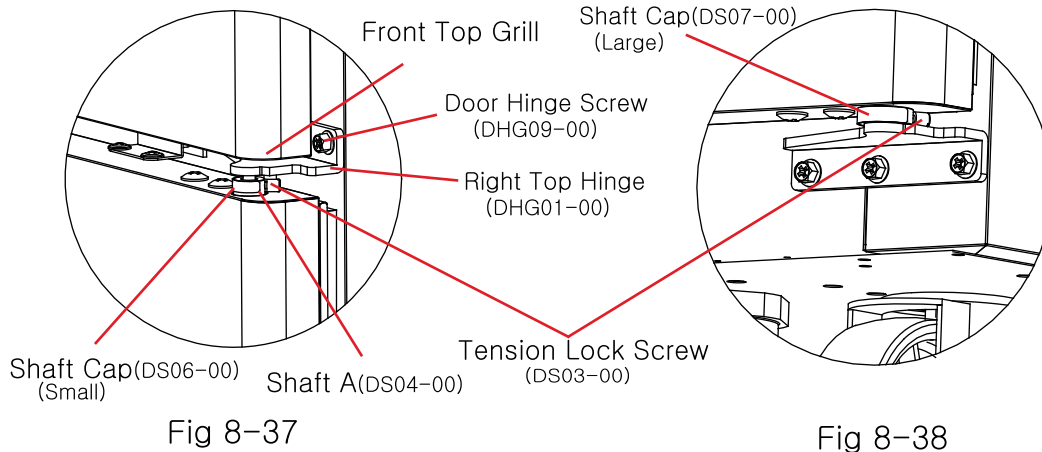

To replace the door, remove the tension between the shaft and spring. Refer to figures 8-37 and 8-38.

Preparation : (1) Small size screwdriver, (2) small steel sticks.

WARNING : Take extra precaution when handling spring tension. Make sure to follow procedure.

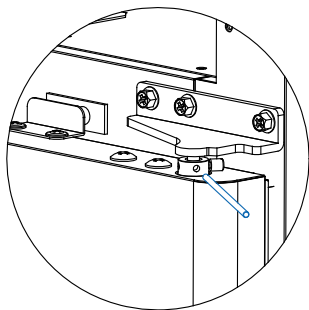

Fig 8-39

1. Remove the front top grill and shaft cap. Insert the steel stick between the shaft holes. (Fig 8-39)

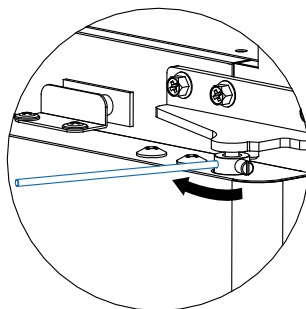
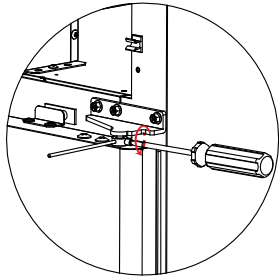

Fig 8-40

2. To remove the tension pin, slightly turn the stick along the direction of the arrow. Maintain the position of the stick by resisting the spring tension. (Fig 8-40)

Fig 8-41



3. Turn and detach the tension pin by using the a (-) screwdriver. Avoid dropping or losing the pin. (Fig 8-41)

Fig 8-42

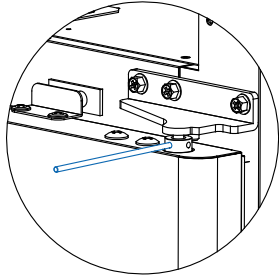

4. Take the steel stick and slowly loosen it toward the direction of the arrow. If tension is completely released before the stick touches the body, remove the stick from the shaft and go to the next step. (Fig 8-42)

Fig 8-43

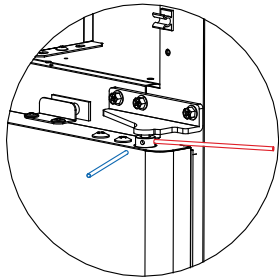

5. If tension is still present even after completing steps 1 through 4, repeat the procedure by using the steel stick. (Fig 8-43)

6. If tension on the upper spring is completely released, repeat the above procedure on the lower one.

Fig 8-44

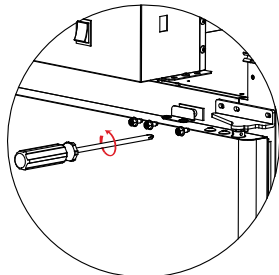

7. While supporting the door so it does not detach, unscrew the three bolts that hold the upper hinge in place. (Fig 8-43)

8. While lifting the door up, completely detach the door from the lower hinge shaft. (Fig 8-45)

Fig 8-45

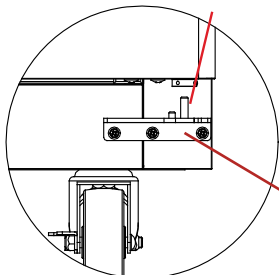

9. Attach the new door or proceed to the next step.

Right Bottom Hinge (DHG02-00)

8.7.2 Door Tension Adjustment

Fig 8-46

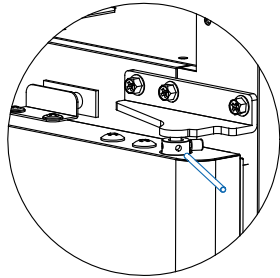

1. Remove Front Cover Grill and Shaft Cap. Insert one steel stick into the shaft hole. (Fig 8-46)

Fig 8-47

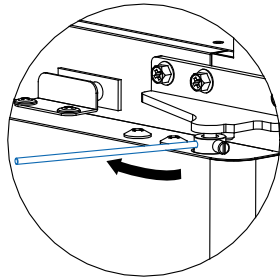

2. To remove the tension pin, slightly turn the stick in the direction of the arrow. Maintain the position of the steel stick by resisting the spring tension. (Fig 8-47)

Fig 8-48

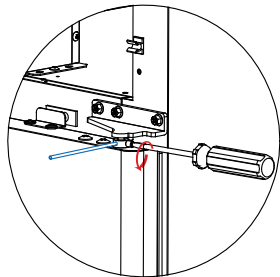

3. Turn and detach the tension pin by using a (-) screwdriver. Avoid dropping or losing the pin. (Fig 8-48)

Fig 8-49

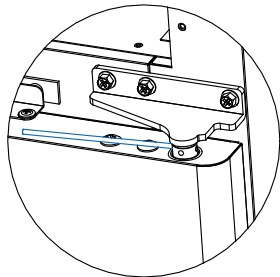

4. Turn the stick in the direction of the arrow until the next hole is visible. Avoid dropping or losing the pin. (Fig 8-49)

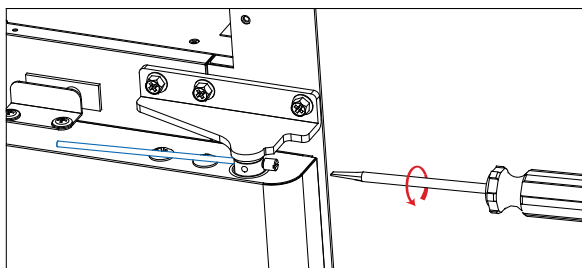

Fig 8-50

5. Turn and drive the tension pin into the next step hole. (Fig 8-50)
6. Adjust the tension of the lower shaft.

8.7.3 Door Gasket

1. Keep the door open.
2. Firmly grasp the door gasket on the top corners with both hands.
3. Slowly pull the gasket out of the slotted groove. Continue until the gasket is removed.
4. To install the replacement door gasket, start snapping it into the groove at the top of the door. Begin at the two corners and move evenly from each side towards the middle as shown below (Fig 8-51)
5. Work the gasket evenly down both sides and then across the bottom, (Fig 8-51)

CAUTION : Do not stretch or bend the door gasket.

Reinstall Gasket following instructions from 1 to 5

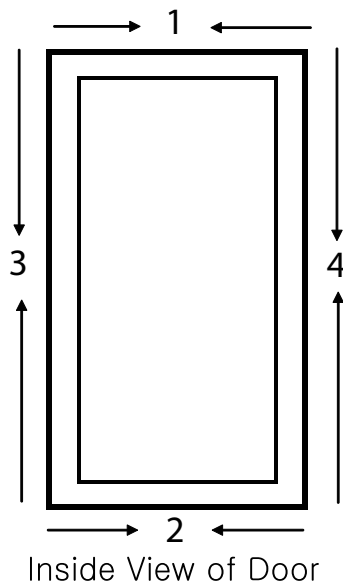

Pic 8-51

9.1 SERVICE DIAGNOSTIC CHART

Symptom	Possible Cause	Corrective Action	References
Unit Does not run	Main power button on control box is OFF.	Press and hold "POWER ON/OFF" button on the control box.	7.3
	Voltage is too low.	Correct the electrical service so it does not vary more than +/- 10%.	
	Electronic Controller is defective.	Replace the Electronic Controller	8.1.3
	Compressor is defective.	Replace the compressor.	8.2.2
	Relay and/or capacitor is defective.	Replace the relay and/or capacitor.	
	Delay time.	It takes about one (1) minute to run the unit after plug-in.	7.9
Cabinet does not maintain proper temperature	High pressure in refrigeration system		
	- Condenser coil is too dirty.	Clean the condenser coil.	3.2
	- Refrigerant was overcharged.	Evacuate and recharge the system with proper amount of refrigerant.	
	- Condenser fan motor does not run.	Check motor electrically, replace if defective.	8.2.5
	- Evaporator fan motor does not run.	Check motor electrically, replace if defective.	8.2.6
	- Capillary tube is clogged.	Evacuate and recharge the system	
	- Clearance around the unit is insufficient.	Reinstall the unit.	4
	- Condenser air is recirculating or ambient temperature is above specification.	Reinstall the unit.	4
System is on "Defrost Cycle".	During the defrost cycle, compressor and fan motor of the evaporator & condensing do not run. The cycle is terminated by both temp (61F) and time (within 20 minutes). Factory defrost setting is 4 times a day for both freezers and refrigerators.	7.9	

Door(s) difficult to open.	Pressure (vacuum) relief control is not functioning.	Check the component, replace if defective.	
	Wrong installation.	Check casters and floor to see if the unit is properly leveled.	4
Water is leaking	In the Cabinet.		
	– Drainage tube is not inserted.	Open the evaporator drain cover and check the drainage tube.	8.4
	– Evaporator drain cover is broken.	Check if there is any crack, replace if damaged.	8.4
	Out of the Cabinet.		
	– Condensate pan heater located at bottom of unit is defective.	Check electrically first, and replace the wire type condensate pan heater if defective.	8.5
Noise	In the cabinet.		
	– Evaporator motor fan damaged due to ice built on evaporator coil.	Check the defrost heater or control box to see if they are energizing. Replace defrost heater or Electronic Controller if defective.	8.2.7
	Out of Cabinet.		
	– Condensing motor fan blades are broken.	Replace the fan blades.	8.2.5
	– Condensing motor is defective.	Check motor, replace if necessary.	8.2.5