



**Models:**

- ▶ **CBS-2031ee CBS-2032ee**
- ▶ **CBS-2041ee CBS-2042ee**



**CBS-2031ee**



**CBS-2032ee**



**CBS-2041ee**



**CBS-2042ee**



**NOTICE TO INSTALLER:** Please leave this book with the machine.

*Driven To Pioneer Innovation™*

**Table of Contents**

Contact Information .....	2	Programming .....	9
Description & Features .....	2	Batch Settings .....	9
Specifications .....	2	Temperature Settings .....	10
Requirements .....	2	Advanced Settings and Diagnostics .....	10
Weights and Capacities .....	2	Error Codes .....	12
Electrical Configuration and Brewing Efficiency .....	3	Service and Support .....	13
Dimensions & Utility Connections .....	4	Cleaning & Maintenance .....	13
Installation .....	6	Parts .....	14
Operating Instructions .....	8		

FETCO®, LUXUS®, EXTRACTOR® and Driven To Pioneer Innovation™ are trademarks or trade names of Food Equipment Technologies Company.

## Contact Information

**FETCO®**  
Food Equipment Technologies Company  
600 Rose Road  
Lake Zurich • IL • 60047-0429 • USA

**Phone:** (800) 338-2699 (US & Canada)  
(847) 719-3000  
**Fax:** (847) 719-3001

**Email:** sales@fetco.com  
techsupport@fetco.com

**Internet:** www.fetco.com

---

## Description & Features

The CBS-2030ee and CBS-2040ee series brewers feature our patented intermittent spray over technology, which works like this:

The following variables are programmed for each batch size:

- ❖ Brew volume
- ❖ Prewet percent (Percentage of the brew volume)
- ❖ Brew time
- ❖ Prewet delay (The time between prewetting and the brew cycle.)
- ❖ Drip delay (The time that the brew light continues to flash after the brew cycle.)

Using these variables, the software calculates how much water to use for prewetting, and brewing. The total brew time is divided into several 30 second cycles. Within these cycles, the software calculates how long to spray water over the coffee grounds, and how long to pause before the next cycle begins.

### Features

- ❖ Two fully programmable batch sizes per side
  - ❖ Adjustable prewetting cycle
  - ❖ Brew at temperature protection
  - ❖ Cascading Spray Domes
  - ❖ Water hardness detection
  - ❖ User selectable "ECO" power saver
- 

## Specifications

### Requirements

- ❖ **Water Requirements:**
  - CBS-2031ee: 20-75 psig, ½ gpm
  - CBS-2032ee: 20-75 psig, 1 gpm
  - CBS-2041ee: 20-75 psig, 1 gpm
  - CBS-2042ee: 20-75 psig, 1 ½ gpm
- ❖ **Electrical:** See electrical configuration chart.
- ❖ **Coffee Filters:** 13" X 5" FETCO Product # F002

### Weights and Capacities

Brewer Model	Weight (empty)	Water tank Capacity & Weight.		Weight (filled)	Dispenser Weight, ea.	Dispenser Filled, ea..	Total Weight Brewer & Dispensers, Filled
CBS-2031ee	32 lbs.	3.0 gal.	25 lbs.	57 lbs.	4.4 lbs.	11 lbs.	68 lbs.
CBS-2032ee	44 lbs.	5.4 gal.	45 lbs.	89 lbs.	4.4 lbs.	11 lbs.	111 lbs.
CBS-2041ee	40 lbs.	4.2 gal.	35 lbs.	75 lbs.	8 lbs.	16 lbs.	91 lbs.
CBS-2042ee	53 lbs.	7.4 gal.	61 lbs.	114 lbs.	8 lbs.	16 lbs.	146 lbs.

# Electrical Configuration and Brewing Efficiency

## USA & Canada

### CBS-2031ee

3.0 liters per batch

Electrical Config. Code	Heater Configuration	Voltage (AC)	Phase	Wires	KW	Maximum Amp draw	Batches per Hour* (max 11)	
							Cold Water	Hot Water
E31015E	1 X 2.3 KW	120	single	2 + ground	2.4	19.7	7.4	11.0

### CBS-2032ee

3.0 liters per batch

Electrical Config. Code	Heater Configuration	Voltage (AC)	Phase	Wires	KW	Maximum Amp draw	Batches per Hour* (max 22)	
							Cold Water	Hot Water
E32015E	2 X 3 KW	120/208	single	3 + ground	4.6	22.4	14.6	22.0
		120/220			5.1	23.7	16.3	22.0
		120/240			6.1	25.8	19.4	22.0

### CBS-2041ee

1.0 gallon per batch

Electrical Config. Code	Heater Configuration	Voltage (AC)	Phase	Wires	KW	Maximum Amp draw	Batches per Hour* (max 11)	
							Cold Water	Hot Water
E41016E	1 X 2.3 KW	120	single	2 + ground	2.4	19.7	5.9	11.0

### CBS-2042ee

1.0 gallon per batch

Electrical Config. Code	Heater Configuration	Voltage (AC)	Phase	Wires	KW	Maximum Amp draw	Batches per Hour* (max 22)	
							Cold Water	Hot Water
E42016E	2 X 3 KW	120/208	single	3 + ground	4.6	22.4	11.5	22.0
		120/220			5.1	23.7	12.9	22.0
		120/240			6.1	25.8	15.4	22.0

\* Based on standard factory settings: 4.0 minute brew time; 0% prewet; 200 F water.

# Dimensions & Utility Connections

## CBS-2031ee

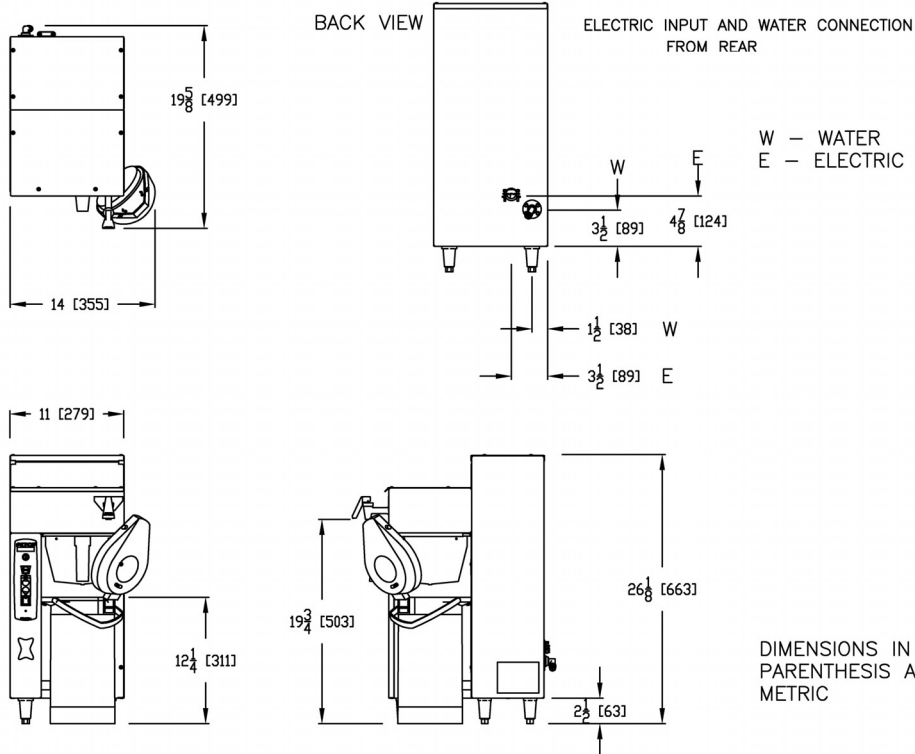

DWG 201141-000

## CBS-2032ee

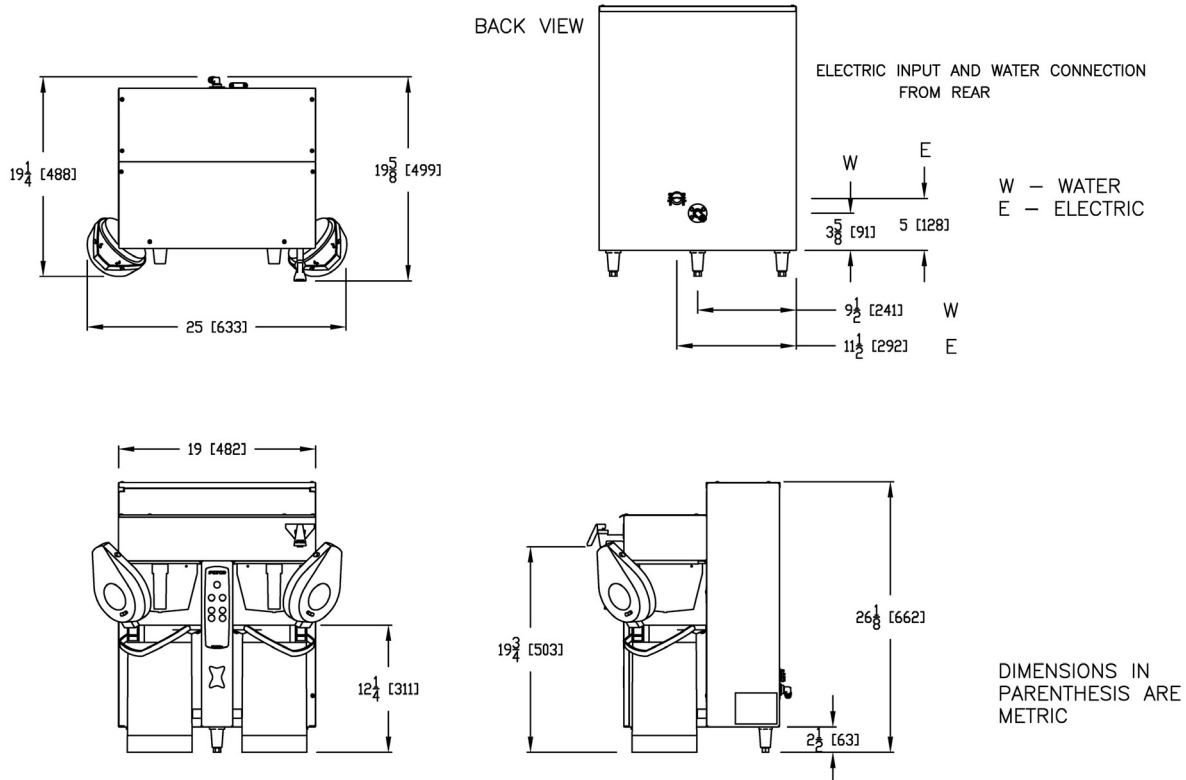

DWG 201142-000

**CBS-2041ee**

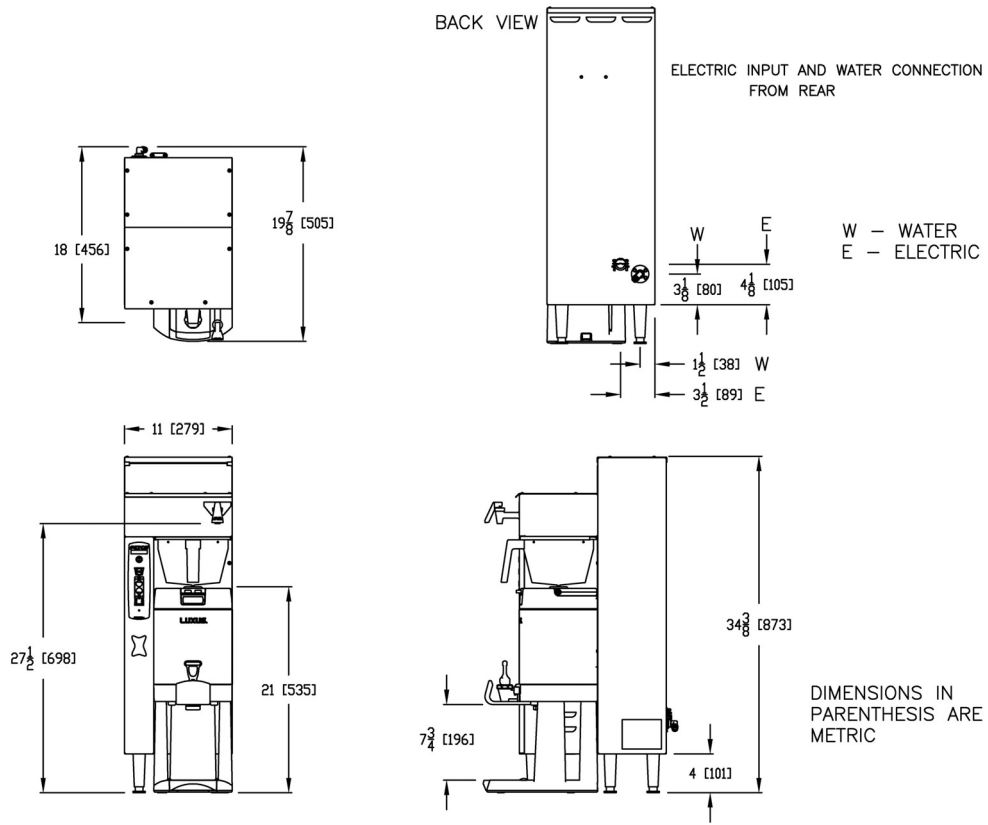

**DWG 201143-000**

**CBS-2042ee**

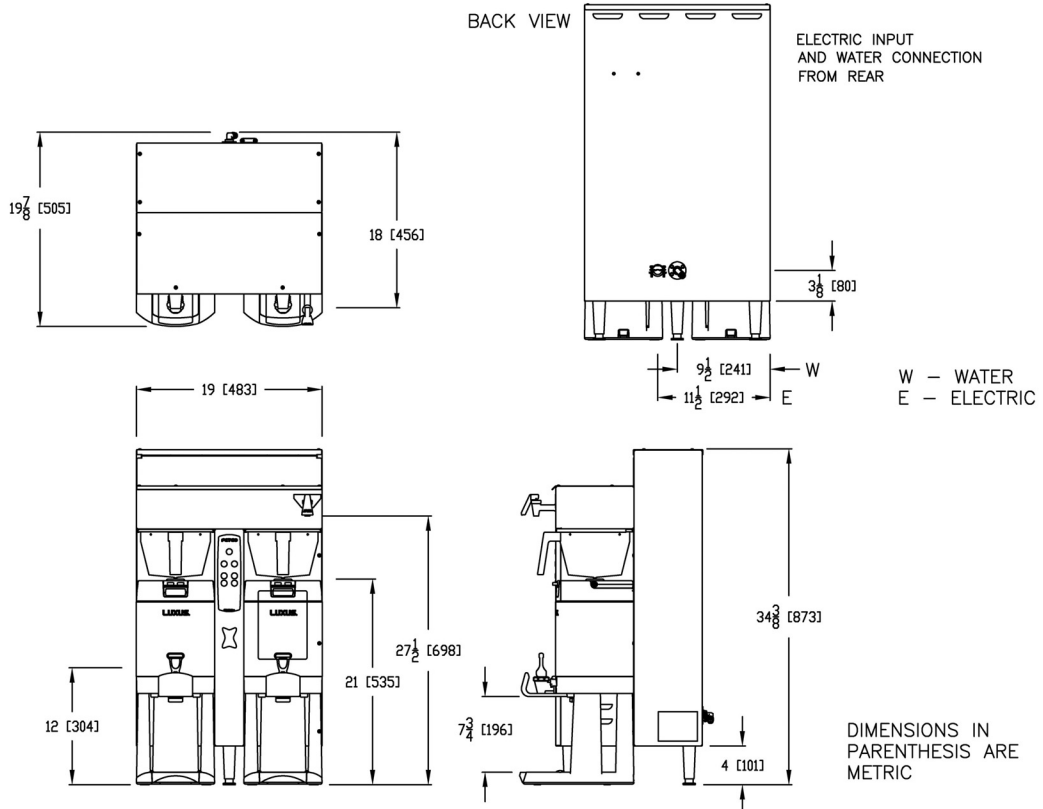

**DWG 201144-000**

# Installation

(For Qualified Service Technicians Only)

## Keys To A Successful Installation

If not installed correctly by qualified personnel, the brewer will not operate properly and damage may result. Damages resulting from improper installation are not covered by the warranty.

Here are the key points to consider before installation:

### Electrical:

- ❖ All FETCO brewers require **NEUTRAL**. Ground is not an acceptable substitute. Installation without neutral may cause damage to the electronic components.
- ❖ The electrical diagram is located on the inside of the lower cover.
- ❖ The installation must comply with applicable federal, state, and local codes having jurisdiction at your location. Check with your local inspectors to determine what codes will apply.

### Plumbing:

- ❖ This equipment is to be installed to comply with the applicable federal, state, or local plumbing codes.
- ❖ The water line must be flushed thoroughly prior to connecting it to the brewer to prevent debris from contaminating the machine.
- ❖ Before connecting it to the brewer, verify that the water line pressure is 20 – 75 psig and the flow rate meets the following minimum requirements:

CBS-2031ee: ½ gpm	CBS-2041ee: 1 gpm
CBS-2032ee: 1 gpm	CBS-2042ee: 1 ½ gpm

### General:

- ❖ Utilize only qualified beverage equipment service technicians for installation. A Service Company Directory may be found on our web site, <http://www.fetco.com>.

## Installation Instructions

### Brewer Setup

1. Review the Dimensions for the unit you are installing. Verify that the brewer will fit in the space intended for it, and that the counter or table will support the total weight of the brewer and dispensers when filled.
2. The brewer's legs are shipped inside the brew baskets. Remove the brew basket(s) and the coffee dispenser(s). Place the brewer on its back and screw in the legs.
3. Place the brewer on the counter or stand.
4. When the brewer is in position, level it front to back as well as side to side by adjusting the legs.
5. Remove the lower cover to access the water and electrical connections. Knock-outs are provided in the back and base of the brewer body for the connections.

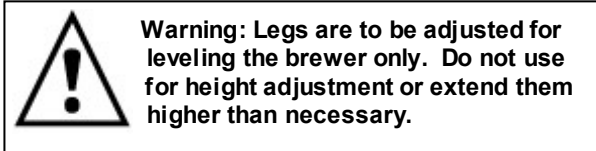

### Water Connection

1. Water inlet is a 3/8 inch male flare fitting.
2. The brewer can be connected to a cold or hot water line. Cold water is preferred for best coffee flavor, but hot water will allow for faster recovery times.
3. Install a water shut off valve near the brewer to facilitate service. If an in-line water filter is used, it should be installed after the water shut off valve and in a position to facilitate filter replacement.
4. Flush the water supply line and filter **before** connecting it to the brewer.
5. Verify that the water line meets the pressure and flow requirements listed above.

### Electrical Connection – US & Canada

1. Verify that the actual voltage at the electrical service connection is compatible with the specifications on the brewer's serial number label. Make sure the electrical service includes **neutral**.
2. The temperature and water tank fill level are pre-set at the factory. There is no need to turn off the heaters during the installation process. The heaters are disabled by the control board until the tank is full of water. The heating process will start automatically when the tank has filled.
3. The CBS-2031ee and CBS-2041ee models are factory equipped with a 120 V cord and plug. The CBS-2032ee and 2042ee have only a terminal block for connecting the incoming power wires. Consult local codes to determine if a cord and plug can be installed, or if the unit must be hard wired.

4. A fused disconnect switch or circuit breaker on the incoming power line must be conveniently located near the brewer, and its location and markings known to the operators.
5. The body of the brewer must be grounded to a suitable building ground. A ground lug is provided in the brewer next to the power terminal block. Use only 10 gauge copper wire for grounding.
6. Electrical connections must be secured in-place within the unit to meet national and local standards.
7. Finally, plug the brewer in to the appropriate outlet (120 VAC models), or connect the incoming power wires to the terminal block as shown in accordance with applicable codes (120/208-240 VAC models only).

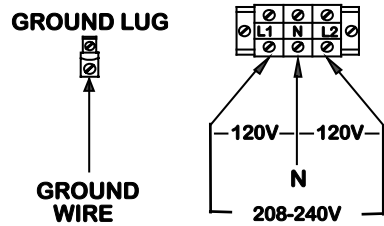
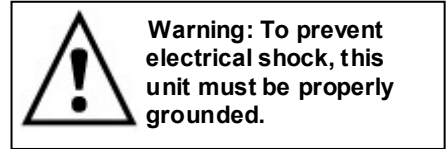

**Final Setup**

1. Turn on the incoming water supply line and inspect both inside and outside of the brewer for leaks in all fittings and tubes
2. Turn on the incoming power.
3. Press the brewer's power switch, which is near the top of the control panel.
4. Within 6 seconds, the hot water tank will begin filling until the water is sensed by the probe at the top of the tank. The display will read "FIL". The heaters will be disabled by the control board until the tank is full.
5. While the water is heating, the display will read "LO" and the actual water temperature will be displayed. After the water has reached the set temperature, the display will be blank. There is no "ready" light.
6. Review the Operating Instructions. Brew one full batch (water only) on each side to confirm proper fill levels. The brewer is factory set with water only (no coffee) to dispense the correct amount of water. If the actual volume is slightly different from the programmed volume, fine-tuning the brewer may be necessary. See #60 – 61 in the Advanced Settings & Diagnostics section.
7. Re-attach the covers after one final inspection for leaks. Look closely in the top of the brewer at the dispense fittings during this inspection.

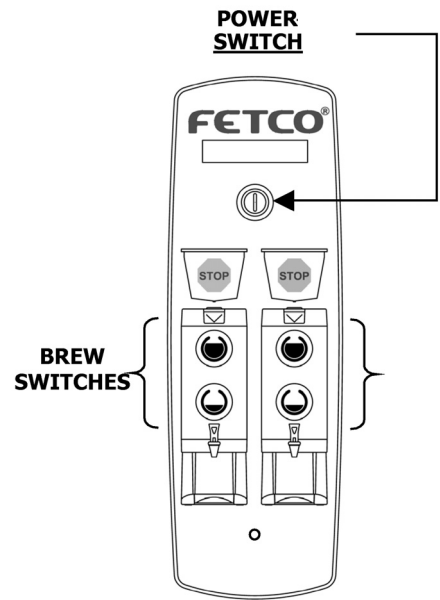

**Operator Training**

Review the operating procedures with whoever will be using the brewer. Pay particular attention to the following areas:

1. Always pre-heat the dispensers before the first use of each day by filling them half way with hot water, and letting them stand for at least 15 minutes.
2. Don't remove the brew basket until it has stopped dripping.
3. Make sure the dispenser is empty before brewing into it.
4. Show how to attach covers, close, and or secure the thermal dispensers for transporting.
5. Show how to remove and clean the Cascading Spray Domes.
6. Show the location and operation of the water shut off valve as well as the circuit breaker for the brewer.
7. Steam from the tank will form condensation in the vent tubes. This condensation will drip into and then out of the brew baskets. 1/4 cup discharging overnight is possible. Place an appropriate container under each brew basket when not in use.
8. We recommend leaving the power to the brewer on overnight. The water tank is well insulated and will use very little electricity to keep the tank hot. Leaving the brewer in the on position will also avoid delays at the beginning of shifts for the brewer to reach operating temperature.

# Operating Instructions

## Control Panel Functions

*Only switches that are active are illuminated.*

*Switches that are inactive or disabled are invisible.*

### 1 Power Switch

- Turns brewer on and off.
- To turn on, press and hold briefly until display reads **S t b**.

### 2 Display

- "FILL" = Water tank is filling.
- "LO XXX" = Unit is heating, not ready to brew. (XXX = actual temperature.)
- Blank = Ready to brew.
- Also displays error messages.

### 3 Stop Switches

- Stops brew cycle
- Lit = Brew cycle in progress
- Invisible = Not brewing, or dripping in progress

### 4 Brew Switches

- Starts brew cycle
- Must be held in for 1 second
- Flashing = Brew cycle in progress
- Lit = Ready to brew
- Invisible – Not ready to brew, or batch disabled (See Programming Section)

### 5 Power Indicator Lamp

- The lamp is lit whenever the unit is connected to a power source.

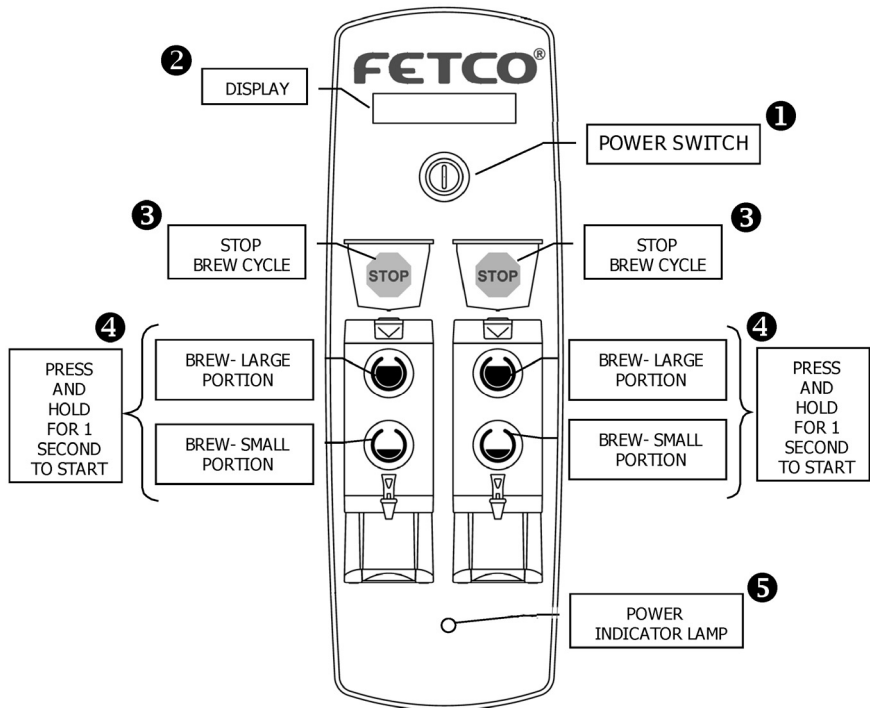

## Brewing

1. Turn the power switch on.
2. Prepare a brew basket with the correct size filter and appropriate amount of coffee.
3. Slide the brew basket completely into the rails.
4. Place a clean, empty, preheated dispenser under the brew basket.
5. Select a batch from the available choices, and hold the corresponding BREW button in for 1 second to start the brew cycle.
6. The STOP button will illuminate, and the selected BREW button will flash, indicating that brewing is in progress. All other BREW buttons will extinguish.
7. When the brew cycle is finished, the STOP button will extinguish and the BREW button will continue to flash for the amount of time programmed into the drip delay setting. This indicates that coffee may still be dripping from the bottom of the brew basket.
8. Before removing the brew basket or dispenser, visually verify that dripping has stopped.

#### Notes:

- Preheat dispenser by filling at least ½ full with water at brewing temperature. Allow it to sit for at least 15 minutes before draining.

# Programming

## Batch Settings

- ❖ Turn the brewer off by pressing the power switch.
- ❖ Press and hold the power switch until the display reads **P r G**. The left side **STOP** button will illuminate.
- ❖ Quickly press the **STOP** button.
- ❖ The display will show the software version. Example:
- ❖ Press **STOP** to continue.
- ❖ Batches are numbered 1 – 2 (single side) or 1 – 4 (dual side)

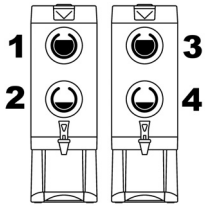

Example: Left Side – Large Batch – Volume 1.0 Gal.

- ❖ Next, the first batch parameter is displayed – batch 1, brew volume. Use the **SCROLL UP** and **SCROLL DOWN** buttons to adjust. Press the **STOP** button to go to the next parameter – brew time.
- ❖ Continue this way until all parameters are programmed for batch #1. (See the chart below for an explanation of each parameter.)
- ❖ Next, batch #2 programming begins. Batches 2 and 4 may be disabled by leaving them set to “**OFF**”. Change to “**ON**” to enable. Batches 1 and 3 cannot be disabled.
- ❖ After all batches are programmed, go to temperature settings.

## Display

**P r G**

**0.0 03.L**

**1.1 1.00**

**1.2 4.00**

**2.0 OFF**

**7 200**

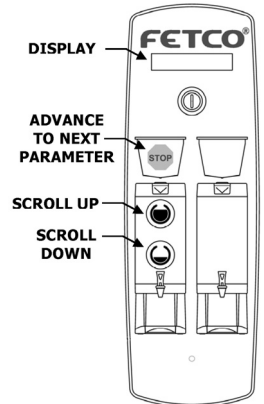

(See next page)

**Important!** After programming, you must press and hold the **STOP** button until the display reads **STO** to save the settings and exit programming mode, or changes will be lost. You may exit programming at any time.

## Batch Parameters

X=Batch Number (1 - 4)					
Parameter	Name	Range	Increment	Default Setting	Comment
X.0	Batch Enabled or Disabled	On/Off		Batch 1 & 3 = ON Batch 2 & 4 = OFF	Batch 1 & 3 cannot be disabled.
X.1	Brew Volume:				
	CBS-2031ee/2032ee	0.94 – 4.72	0.01	2.49 liters	To change setting to liters or gallons, see # 59 in Advanced Settings section.
	CBS-2041ee/2042ee	0.25 – 1.25	0.01	1.0 gallons	
X.2	Brew Time (Min:Sec)	2:00 – 9:30	0:30	4:00 minutes	
X.4	Prewet Percent	0.00 – 15.0%	1%	0 %	Percentage of total brew volume
X.5	Prewet Delay (Min:Sec)	0:10 – 5:00	0:10	1:00 minute	The time between prewetting and start of brew cycle.
X.6	Drip Delay (Min:Sec)				
	CBS-2031ee/2032ee	0:30 – 6:00	0:10	1:00 minute	The time between end of brew cycle and unlocking of brew basket.
	CBS-2041ee/2042ee	0:30 – 6:00	0:10	1:30 minute	

## Temperature Settings



Parameter	Name	Range	Default Setting	Comment
7	Water Temp. (°F)	188°F - 206°F	200°F	Inside tank. Will be slightly lower at spray head. To display in ° Celsius, see # 58 in Advanced Settings.
7.1	ECO Mode	OFF/ON	OFF	ON= After 1 hour passes without brewing, the temperature setting will automatically be lowered by 30°F, and the display will read ECO. Press STOP to resume normal heating. The hot water faucet may be used without affecting the ECO cycle, however the temperature of the dispensed water may be lower than desired.
9	Brew at Set Temperature	0 - 1	1	0=Will brew at any temperature. 1=Will brew only at set temperature. Note: Changes will not take effect until the next brew cycle is completed.

Parameter	Name	Range	Default Setting	Comment
10	Enter Advanced Settings & Diagnostics	0 - 1	0	0 = Skip Advanced Settings & Diagnostics. Loop back to start of batch programming cycle. 1 = Enter Advanced Settings & Diagnostics. Press <b>STOP</b> to continue

**Important!** To save your changes, press and hold **STOP** until the display reads **STO** to exit programming mode and return to operating mode.

## Advanced Settings and Diagnostics

Address	Description	Range	Default	Comment
50	Water Level in Tank	0 - 1		Tests if water is touching probe. 0 = Tank is less than full 1 = Tank is full
51	Water Resistance (KΩ)	0 – 200		Displays the electrical resistance of the water in kilohms as measured between the water level probe and the tank. If greater than 200, or if the tank is not full, the display will read ---.
53	Power Relay State	0 – 1		To check the function of the power relay, press the power button repeatedly. The display should toggle between 0 and 1.
54	Water Level Sensitivity	LO - HI	LO	LO – 0 to 50 KΩ HI – 50 to 130 KΩ If water resistance (address 51) is greater than 25 KΩ, set on HI to prevent unwanted filling of tank.
55	Tank Temperature	180°F - 208°F		Displays current tank temperature.
56	Brewer Model Number	31 – 41 or 32 - 42		Must be set for the correct model number of the brewer: 31 for CBS-2031ee, 32 for CBS-2032ee, 41 for CBS-2041ee, 42 for CBS-2042ee.
57	Reload Defaults	0 - 1	0	Changes all settings to default factory settings. 0 = Do not reload defaults 1 = Reload all default settings If 1 is selected, you must advance to the next address for this change to take effect. Does not change address 56 – model number.
58	Temperature Scale	F or C	F	F = Fahrenheit      C = Celsius
59	Water Volume Scale			GAL = Displays volume in gallons LTR = Displays volume in liters
	CBS-2031ee/2032ee	GAL or LTR	LTR	
	CBS-2041ee/2042ee	GAL or LTR	GAL	

Address	Description	Range	Default	Comment														
60 and 61	Left Brew Valve Flow Rate Right Brew Valve Flow Rate			Use this to compensate for minor discrepancies in actual volume versus programmed volume. Set lower to increase volume, higher to decrease volume. The following formula can be used to determine the correct setting:  $\frac{\text{ACTUAL VOLUME}}{\text{PROGRAMMED VOLUME}} \times \text{CURRENT SETTING} = \text{NEW SETTING}$														
	CBS-2031ee/2032ee	0.35 – 2.24 <i>If #59 is LTR</i>  or 0.09 – 0.59 <i>If #59 is GAL</i>	1.30   0.34															
	CBS-2041ee/2042ee	0.09 – 0.59 <i>If #59 is GAL</i>  or 0.35 – 2.24 <i>If #59 is LTR</i>	0.40   1.51															
64	Keypad Test	0 - 1	0	Tests function of control panel switches. Starting at the batch buttons, press each button that is lit. The display will show the name of the switch being pressed and the switch light will go out. Brew switches are named S1, S2, S3, etc. The left STOP switch must be pressed last, as this will exit the test.														
65	Relay Test		0	Tests the individual relays that control various components. 0 - Skip relay test. To start Relay Test, press top batch button – display will read OFF. Press power switch – display will read ON.  Press <b>STOP</b> to continue. Use the batch buttons to turn each component ON and OFF.														
<table border="1" style="width: 100%;"> <tr> <td rowspan="5" style="text-align: center; vertical-align: middle;">  <p><b>Warning:</b> During these tests, hot water may be dispensed from the valve being tested.</p> </td> <td style="text-align: center;"><b>Address</b></td> <td style="text-align: center;"><b>Description</b></td> </tr> <tr> <td style="text-align: center;">90</td> <td>Left or Single Brew Valve</td> </tr> <tr> <td style="text-align: center;">91</td> <td>Right Brew Valve</td> </tr> <tr> <td style="text-align: center;">95</td> <td>Fill Valve</td> </tr> <tr> <td style="text-align: center;">96</td> <td>Heater (To protect the heaters, this test will work only if the tank is full.)</td> </tr> <tr> <td colspan="3">Press <b>STOP</b> to go back to address 65. Press the lower batch button to exit the Relay Test.</td> </tr> </table>					 <p><b>Warning:</b> During these tests, hot water may be dispensed from the valve being tested.</p>	<b>Address</b>	<b>Description</b>	90	Left or Single Brew Valve	91	Right Brew Valve	95	Fill Valve	96	Heater (To protect the heaters, this test will work only if the tank is full.)	Press <b>STOP</b> to go back to address 65. Press the lower batch button to exit the Relay Test.		
 <p><b>Warning:</b> During these tests, hot water may be dispensed from the valve being tested.</p>	<b>Address</b>	<b>Description</b>																
	90	Left or Single Brew Valve																
	91	Right Brew Valve																
	95	Fill Valve																
	96	Heater (To protect the heaters, this test will work only if the tank is full.)																
Press <b>STOP</b> to go back to address 65. Press the lower batch button to exit the Relay Test.																		
67	Factory Use Only – Do not use.																	
<b>Important!</b> To save your changes, press and hold <b>STOP</b> until the display reads <b>STO</b> to exit programming mode and return to operating mode.																		

## Error Codes

Code	Description	Possible Cause	Corrective Action	How to Clear Error Codes
001	Internal Error System had to reload default settings.	Control board failure.	Clear error. Re-program the brewer to the desired specifications. If error occurs again, replace control board.	Press and hold the Power switch for 3 seconds.
002	Power Failure	Power relay feedback loop does not match the state.	Clear error. If error occurs again, call Technical Support for assistance.	Press and hold the Power switch for 3 seconds.
050	Shorted temperature probe.	Probe failure.	Replace probe.	Press and hold the Power switch for 3 seconds.
051	Open temperature probe.	Bad probe connection, or probe failure.	Check all connections. Replace probe if necessary.	Press and hold the Power switch for 3 seconds.
100	Initial Fill Error Initial fill time was more than 15 minutes.	Water supply flow rate is too low.	Watch for short potting during brew cycle. Investigate cause of low flow rate. (Clogged water filter, etc.)	Press and hold the Power switch for 3 seconds.
101	Error on refill Tank did not refill within 3 minutes.	Water supply flow rate is too low.	Watch for short potting during brew cycle. Investigate cause of low flow rate. (Clogged water filter, etc.)	Press and hold the Power switch for 3 seconds.
102	Unwanted Fill When brewer is idle, the fill valve was activated for more than 30 seconds during a 1 hour period.	Possible leak in tank, fitting, or valve.	Check inside of machine for leaks.	Press and hold the Power switch for 3 seconds.
		Water supply flow rate is too low.	Investigate cause of low flow rate. (Clogged water filter, etc.)	
200	Flat Line Temperature (Water is boiling) System is calling for heat, but the temperature does not rise at least 2°F within 10 minutes.	Triac is stuck closed, bad output on control board, or temperature is set too high for altitude.	Check triacs, check control board output, or adjust temperature for altitude.	Press and hold the Power switch for 3 seconds.
201	Heater Open System is calling for heat, but the temperature does not rise at least 2°F within 10 minutes. This error is disabled during brewing and while using the hot water faucet.	Heating element failure.	Check and replace heating elements if necessary.	Press and hold the Power switch for 3 seconds.
202	Heater Short System is not calling for heat, but temperature rises more than 5°F.	Possible triac stuck closed, or bad output on control board.	Check triac and control board.	Press and hold the Power switch for 3 seconds.
255	Keypad Error A switch was pressed for more than 45 seconds.	Switch was held in too long, or switch is stuck closed.	Clear error and try again. If error occurs without switch being pressed, replace control board.	Press and hold the Power switch for 3 seconds.

## Service and Support

For service and support information, contact the Technical Support department. Our hours are 7:00 AM to 6:00 PM Central Time, Monday through Friday.

Phone: (800) 338-2699 or (847) 719-3000

Email: [techsupport@fetco.com](mailto:techsupport@fetco.com)

Utilize only qualified beverage equipment service technicians for service. A Service Company Directory may be found on our web site, <http://www.fetco.com>.

---

## Cleaning & Maintenance

Daily: Wipe the area above the brew baskets to remove coffee residue.

Daily or Weekly: Clean each Cascading Spray Dome with a soft brush and detergent. They may also be cleaned in a dishwasher – top rack only.

Each CSD is held in place by four magnets. To remove, grasp the bottom and pull down.

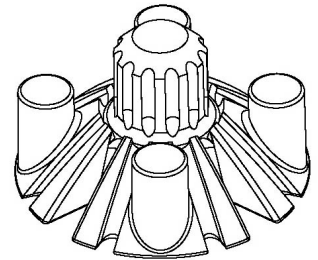

Quarterly:

- Check water temperature and adjust if necessary.
- Check brew levels and adjust if necessary.
- Inspect all fittings and hoses for leaks.
- Inspect inside of tank for lime deposits. De-lime tank and probes if necessary. A qualified service technician should perform this procedure.



ITEM #	QTY	PART #	DESCRIPTION
1	1	001088	WELDMENT CBS-2031ee
2	1	51089	BOARD, SWITCHING / CONTROL, 100-120VAC (SINGLE)
3	8	29007	NUT, #4-40 KNURLED THUMB
4	1	57006	VALVE, S-53 120VAC
5	1	24012	GASKET, S-53 FILL VALVE
6	1	31078	FITTING, S-53 FILL VALVE INLET
7	1	03074	BRACKET, S-53
8	4	82020	SCREW, S-53 FILL VALVE
9	1	31031	FITTING, 90° MALE ELBOW, 3/8 TUBE OD X 3/8 MPT
10	1	86040	CONNECTOR, CABLE CLAMP, 3/4"
11	1	52090	TERMINAL BLOCK, 3 POLE, W/ MARKING STRIP
12	1	65002	CONNECTOR, COPPER LUG
13	5	83026	WASHER, INTERNAL TOOTH LOCK, #8 SCREW SIZE
14	9	84002	NUT, HEX, #8-32 MACHINE SCREW
15	1	24101	O-RING, 3.739" ID X 0.070" CS, 70 DURO, BUNA "N", FDA
16	1	102357	ASSEMBLY, HOUSING SPRAY W/VALVE 120 VAC, CSD Ø 3.6" (SEE FIG. 10)
17	1	102363	ASSEMBLY, CASCADE SPRAY DOME, "EE"
18	1	71021	FAUCET, COMPLETE, HOT WATER, RED SAFETY HANDLE
18		71023	FAUCET UPPER ASSY., HOT WATER, RED SAFETY HANDLE
18		71003	FAUCET SEAT CUP, HOT WATER
19	1	31075	FITTING, 3/8" ID x 1/4" FPT
20	3	86007	CLAMP, HOSE, .593"-.656" DIA RANGE
21	4	83076	WASHER, #8 SCREW SIZE, CUSHION AND SEALING
22	4	73029	LEG, THERMOPLASTIC, 2.50"(63mm)
23	1	104094	ASSEMBLY, TANK CBS-2031ee, O-RING FITTINGS (SEE FIG. 2)
24	1	22125	INSULATION TANK FRONT CBS-2031ee
25	1	22063	INSULATION TANK BACK CBS-2031e
26	1	45097	OVERLAY, CBS-2031ee
27	1	41016	LABEL, EXTRACTOR
28	1	K028	WATER LEVEL PROBE REPLACEMENT, CBS-2030'S
29	1	54026	PROBE, TEMPERATURE 5" LONG, 50k
30	1	25137	TUBE, 5/16" OD X 3/16" ID X 11" LG VENT
31	1	44004	LABEL GROUND
32	1	402094	HARNESS, LOW AMP, CBS-2031ee/41ee
33	1	402095	HARNESS, HIGH AMP, CBS-2031ee/41ee
34	1	63019	CORD, 120 VAC, 12/3 AWG, 20 AMP, W/5-20P NEMA PLUG
35	1	24102	MANIFOLD TEE, REDUCING, WATER DISTRIBUTION, SILICONE
36	1	86038	CLAMP, HOSE, .670"-.780" DIA RANGE
38	1	86016	WORM DRIVE CLAMP 7/16" - 25/32"
39	10	84050	NUT, CLIP ON (J-NUT), #6-32, 22 - 20 GA., BLACK-PHOSPHATE FINISH
40	1	01506	COVER TOP CBS-2031 & 41
41	1	01507	COVER BASE UPPER CBS-2031
42	1	401347	WIRING DIAGRAM, CBS-2031ee/2041ee
43	1	25139	TUBE, 5/8" OD X 3/8" ID X 15" LG DRAIN/FILL
44	1	86030	CLAMP, 3/4" MAX TUBE OD FLOW CONTROL
45	1	44048	WARNING LABEL
46	1	102358	ASSEMBLY, RIGHT COVER CBS-2030's ee
47	10	82053	SCREW, # 6-32 X 1/2" TRUSS HD PH
48	1	101266	ASSEMBLY, BREW BASKET, 13 X 5, DIA HOLE 0.218", 0.25" FLG (SEE FIG. 9)
49	1	44050	LABEL, WARNING, "HOT WATER FAUCET"

**Figure 2 – CBS-2031ee Tank Assembly, Part # 104094**

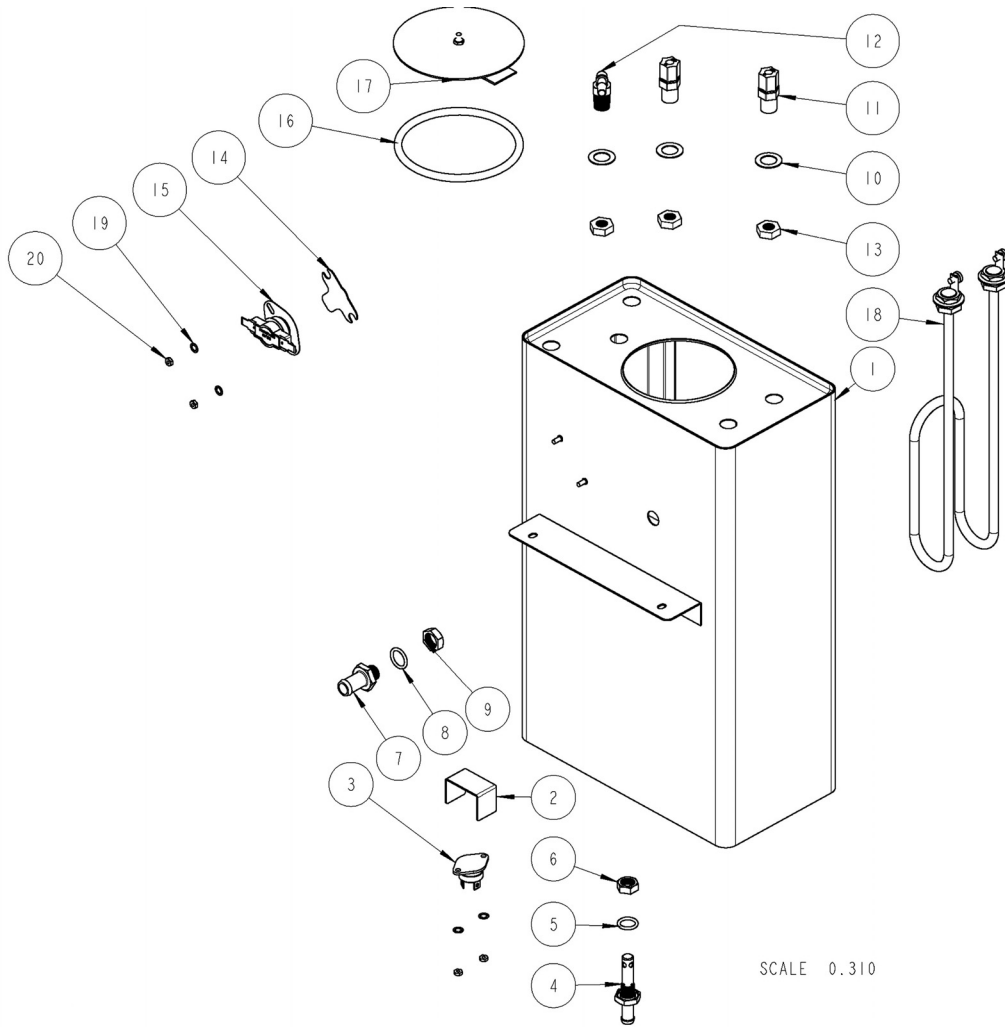

DWG 104094-A

ITEM #	QTY	PART #	DESCRIPTION
1	1	004088	WELDMENT TANK CBS-2031ee, O-RING FITTINGS
2	1	03297	SINK, HEAT FOR 40A TRIAC
3	1	59008	TRIAC 40A, 600V
4	1	13139	FITTING 3/8" HOSE ID WATER INLET/DRAIN
5	1	24099	O-RING, 1/2 X 11/16, 3/32 WIDTH
6	1	13134	NUT FOR 3/8 HOSE ID FITTING
7	1	13137	FITTING 1/2" HOSE ID
8	1	24098	O-RING 9/16 X 3/4, 3/32 WIDTH
9	1	13135	NUT FOR 1/2 HOSE ID FITTING
10	3	83084	WASHER .875"OD X .536"ID, FLA, 22 GA
11	2	25098	FITTING, COMPRESSION MALE CONNECTOR
12	1	25128	FITTING, 90 DEG. ELBOW, 1/4 NPT X 5/16 BARB, KYNAR
13	3	23249	LOCKNUT 1/4"-18 NPT MODIFIED THREAD
14	1	03332	BRACKET 2, ONE SHOT THERMOSTAT
15	1	53071	THERMOSTAT, SINGLE SHOT, 25A
16	1	24002	O-RING, TANK COVER
17	1	102013	ASSEMBLY, TANK COVER
18	1	107020	ASSEMBLY, IMMERSION HEATER, 2300W, 120VAC
19	4	83011	WASHER, #6 SCREW SIZE, INTERNAL
20	4	84045	NUT, HEX 6-32, UNDERSIZED

Figure 3 – CBS-2032ee Main Assembly

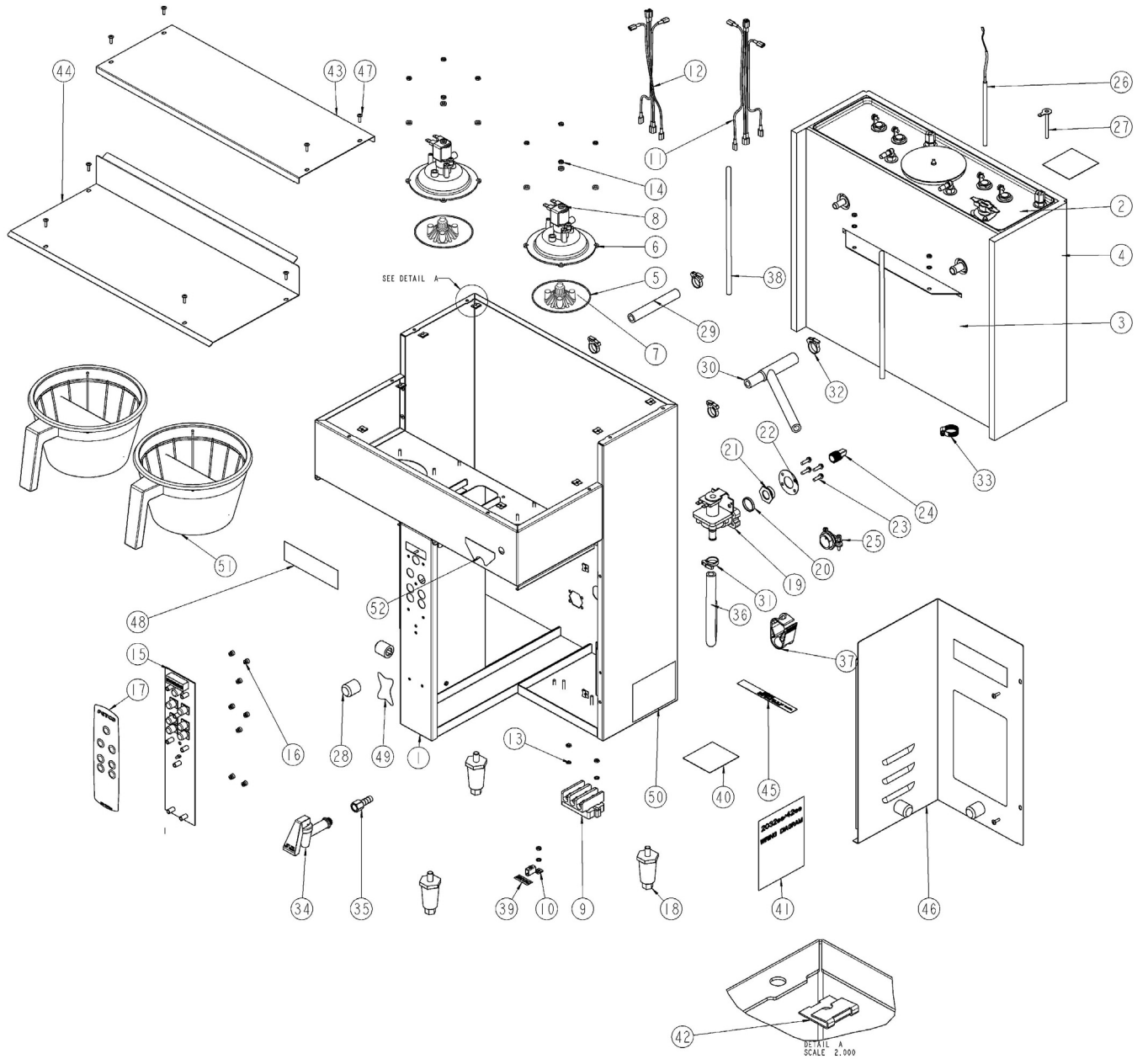

DWG 101270-B

ITEM #	QTY	PART #	DESCRIPTION
1	1	001086	WELDMENT, CBS-2032ee
2	1	104095	ASSEMBLY, TANK CBS-2032ee, O-RING FITTINGS (SEE FIG. 4)
3	1	22126	INSULATION TANK FRONT CBS-2032ee
4	1	22042	INSULATION TANK BACK CBS-2032e
5	2	24101	O'RING, 3.739" ID X 0.070" CS, 70 DURO, BUNA "N", FDA
6	2	102357	ASSEMBLY, HOUSING SPRAY W/VALVE 120 VAC, CSD Ø 3.6" (SEE FIG. 10)
7	2	102363	ASSEMBLY, CASCADE SPRAY DOME, "EE"
8	8	83076	WASHER,#8 SCREW SIZE, CUSHION AND SEALING
9	1	52090	TERMINAL BLOCK, 3 POLE, W/ MARKING STRIP
10	1	65002	CONNECTOR, COPPER LUG
11	1	402096	HARNESS, LOW AMP, CBS-2032ee/42ee
12	1	402097	HARNESS, HIGH AMP, CBS-2032ee/42ee
13	5	83026	WASHER, INTERNAL TOOTH LOCK, #8 SCREW SIZE
14	13	84002	NUT, HEX, #8-32 MACHINE SCREW
15	1	51090	BOARD,SWITCHING/CONTROL, 100-120VAC (DUAL)
16	8	29007	NUT, #4-40 KNURLED THUMB
17	1	45098	OVERLAY CBS-2032ee, ECONOMIC
18	3	73029	LEG, THERMOPLASTIC, 2.50"(63mm)
19	1	57006	VALVE, S-53 120VAC
20	1	24012	GASKET, S-53 FILL VALVE
21	1	31078	FITTING, S-53 FILL VALVE INLET
22	1	03074	BRACKET, S-53
23	4	82020	SCREW, S-53 FILL VALVE
24	1	31031	FITTING, 90° MALE ELBOW, 3/8 TUBE OD X 3/8 MPT
25	1	86040	CONNECTOR, CABLE CLAMP, 3/4"
26	1	54026	PROBE, TEMPERATURE 5" LONG, 50k
27	1	K028	WATER LEVEL PROBE REPLACEMENT, CBS-2030'S
28	2	102195	ASSEMBLY, BUMPER, 2030e
29	1	25140	TUBE, 5/8"OD X 3/8"ID X 4.25"LG BREW
30	1	24102	MANIFOLD TEE, REDUCING, WATER DISTRIBUTION, SILICONE
31	5	86007	CLAMP, HOSE, .593"-.656" DIA RANGE
32	1	86038	CLAMP, HOSE, .670"-.780" DIA RANGE
33	1	86016	WORM DRIVE CLAMP 7/16" - 25/32"
34	1	71021	FAUCET, COMPLETE, HOT WATER, RED SAFETY HANDLE
34	1	71023	FAUCET UPPER ASSY., HOT WATER, RED SAFTEY HANDLE
34	1	71003	FAUCET SEAT CUP, HOT WATER
35	1	31075	FITTING, 3/8"ID x 1/4" FPT
36	1	25139	TUBE, 5/8"OD X 3/8"ID X 15"LG DRAIN/FILL
37	1	86030	CLAMP, 3/4" MAX TUBE OD FLOW CONTROL
38	2	25137	TUBE, 5/16"OD X 3/16"ID X 11"LG VENT
39	1	44004	LABEL GROUND
40	2	44024	LABEL, WARNING-HIGH VOLTAGE
41	1	401348	WIRING DIAGRAM, CBS-2032ee/42ee
42	10	84050	NUT, CLIP ON (J-NUT), #6-32, 22 - 20 GA., BLACK-PHOSPHATE FINISH
43	1	01479	COVER, TOP CBS-2032 & 42
44	1	01463	COVER, UPPER BASE CBS-2032e
45	1	44048	WARNING LABEL
46	1	102358	ASSEMBLY, RIGHT COVER CBS-2030's ee
47	10	82053	SCREW, # 6-32 X 1/2" TRUSS HD PH
48	1	46027	LABEL, SPRAY HOUSING
49	1	41016	LABEL, EXTRACTOR
51	2	101266	ASSEMBLY, BREW BASKET, 13 X 5, DIA HOLE 0.218", 0.25" FLG (SEE FIG. 9)
52	1	44050	LABEL, WARNING, "HOT WATER FAUCET"

**Figure 4 – CBS-2032ee Tank Assembly, Part # 104095**

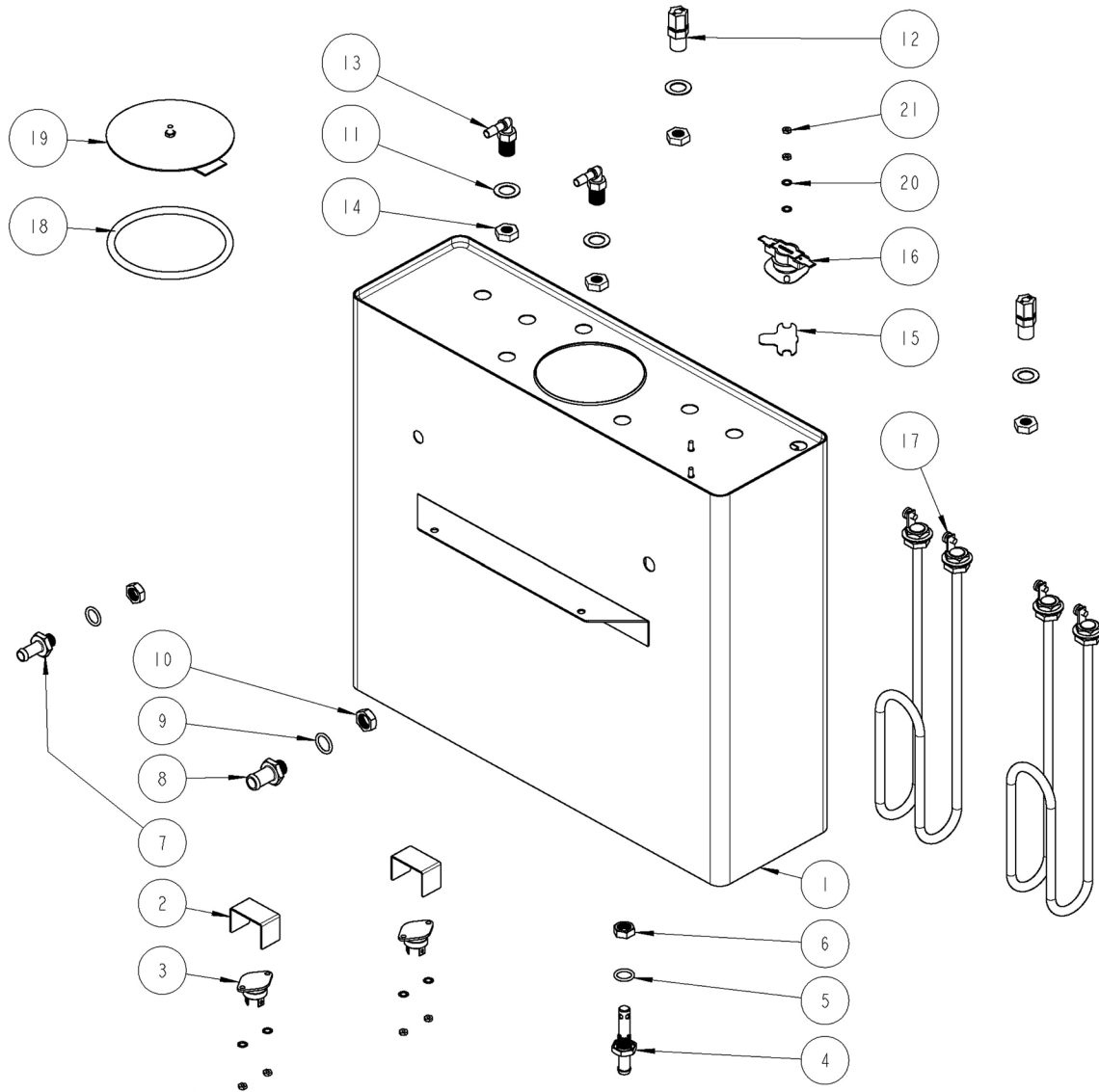

DWG 104095-A

ITEM #	QTY	PART #	DESCRIPTION
1	1	004089	WELDMENT TANK CBS-2032ee, O-RING FITTINGS
2	2	03297	SINK, HEAT FOR 40A TRIAC
3	2	59008	TRIAC 40A, 600V
4	1	13139	FITTING 3/8" HOSE ID WATER INLET/DRAIN
5	2	24099	O-RING, 1/2 X 11/16, 3/32 WIDTH
6	2	13134	NUT FOR 3/8 HOSE ID FITTING
7	1	13138	FITTING 3/8" HOSE ID
8	1	13137	FITTING 1/2" HOSE ID
9	1	24098	O-RING 9/16 X 3/4, 3/32 WIDTH
10	1	13135	NUT FOR 1/2 HOSE ID FITTING
11	4	83084	WASHER .875"OD X .536"ID, FLA, 22 GA
12	2	25098	FITTING, COMPRESSION MALE CONNECTOR
13	2	25128	FITTING, 90 DEG. ELBOW, 1/4 NPT X 5/16 BARB, KYNAR
14	4	23249	LOCKNUT 1/4"-18 NPT MODIFIED THREAD
15	1	03332	BRACKET 2, ONE SHOT THERMOSTAT
16	1	53088	THERMOSTAT, SINGLE SHOT, 240V/40A
17	2	107021	ASSEMBLY IMMERSION HEATER 3000W/240VAC
18	1	24002	O-RING, TANK COVER
19	1	102013	ASSEMBLY, TANK COVER
20	6	83011	WASHER, #6 SCREW SIZE, INTERNAL
21	6	84045	NUT, HEX 6-32, UNDERSIZED

**Figure 5 – CBS-2041ee Main Assembly**

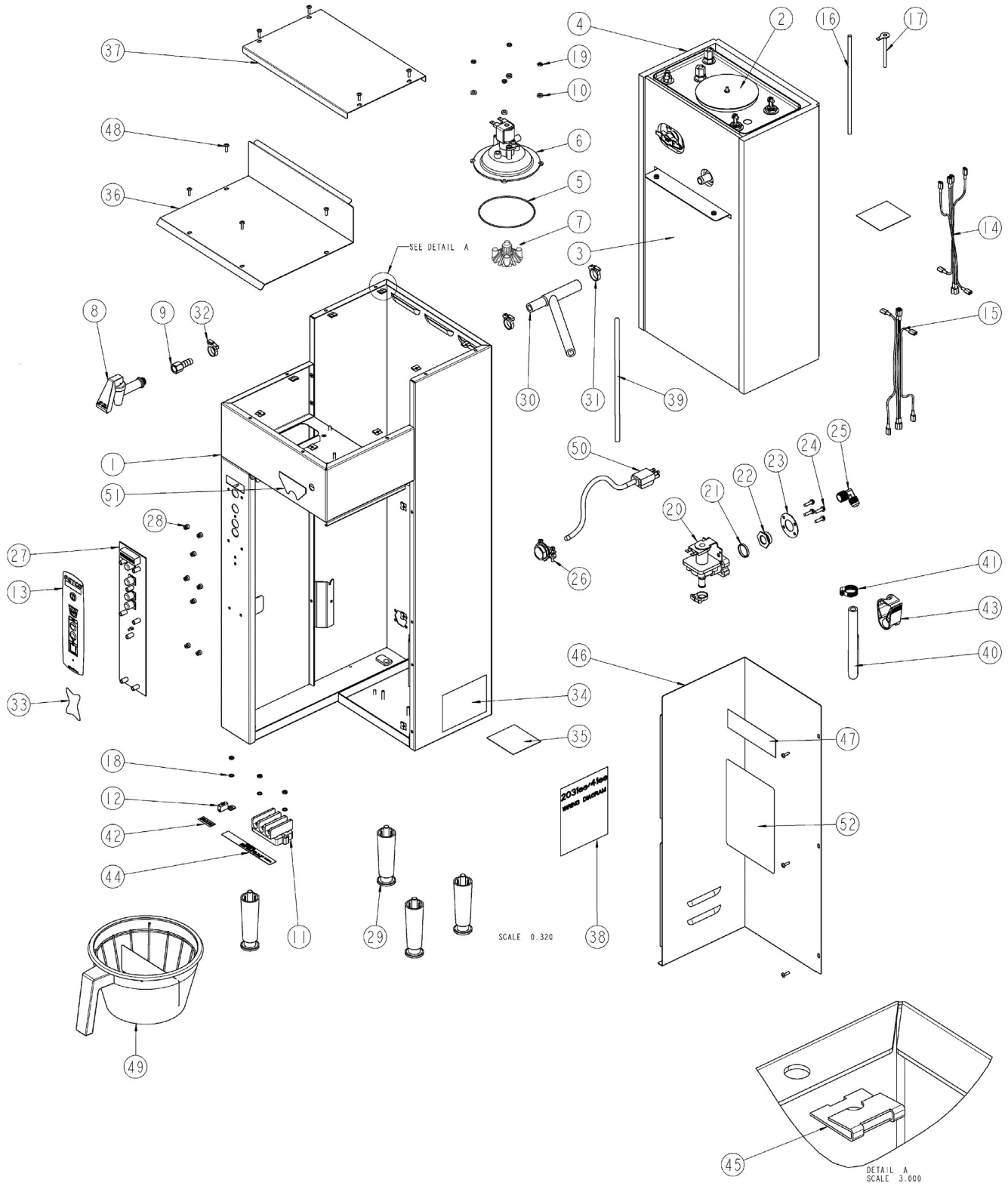

ITEM #	QTY	PART #	DESCRIPTION
1	1	001087	WELDMENT CBS-2041ee
2	1	104097	ASSEMBLY TANK CBS-2041ee, O-RING FITTINGS (SEE FIG. 6)
3	1	22128	INSULATION TANK FRONT CBS-2041ee
4	1	22065	INSULATION TANK BACK CBS-2041e
5	1	24101	O'RING, 3.739" ID X 0.070" CS, 70 DURO, BUNA "N", FDA
6	1	102357	ASSEMBLY, HOUSING SPRAY W/VALVE 120 VAC, CSD Ø 3.6" (SEE FIG. 10)
7	1	102363	ASSEMBLY, CASCADE SPRAY DOME, "EE"
8	1	71021	FAUCET, COMPLETE, HOT WATER, RED SAFETY HANDLE
8	1	71023	FAUCET UPPER ASSY., HOT WATER, RED SAFETY HANDLE
8	1	71003	FAUCET SEAT CUP, HOT WATER
9	1	31075	FITTING, 3/8"ID x 1/4" FPT
10	4	83076	WASHER,#8 SCREW SIZE, CUSHION AND SEALING
11	1	52090	TERMINAL BLOCK, 3 POLE, W/ MARKING STRIP
12	1	65002	CONNECTOR, COPPER LUG
13	1	45099	OVERLAY, CBS-2041EE
14	1	402094	HARNESS, LOW AMP, CBS-2031ee/41ee
15	1	402095	HARNESS, HIGH AMP, CBS-2031ee/41ee
16	1	54022	PROBE, TEMPERATURE 8" LONG, 50k
17	1	K029	WATER LEVEL PROBE REPLACEMENT, CBS-2040'S/50'S
18	5	83026	WASHER, INTERNAL TOOTH LOCK, #8 SCREW SIZE
19	9	84002	NUT, HEX, #8-32 MACHINE SCREW
20	1	57006	VALVE, S-53 120VAC
21	1	24012	GASKET, S-53 FILL VALVE
22	1	31078	FITTING, S-53 FILL VALVE INLET
23	1	03074	BRACKET, S-53
24	4	82020	SCREW, S-53 FILL VALVE
25	1	31031	FITTING, 90° MALE ELBOW, 3/8 TUBE OD X 3/8 MPT
26	1	86040	CONNECTOR, CABLE CLAMP, 3/4"
27	1	51089	OBOARD,SWITCHING / CONTROL, 100-120VAC (SINGLE)
28	8	29007	NUT, #4-40 KNURLED THUMB
29	4	73002	LEG, FLANGE FOOT, 4" HIGH
30	1	24102	MANIFOLD TEE, REDUCING, WATER DISTRIBUTION, SILICONE
31	1	86038	CLAMP, HOSE, .670"-.780" DIA RANGE
32	3	86007	CLAMP, HOSE, .593"-.656" DIA RANGE
33	1	41016	LABEL, EXTRACTOR
35	2	44024	LABEL, WARNING-HIGH VOLTAGE
36	1	01527	COVER BASE UPPER CBS-2041
37	1	01506	COVER TOP CBS-2031 & 41
38	1	401347	WIRING DIAGRAM, CBS-2031ee/2041ee
39	1	25137	TUBE, 5/16"OD X 3/16"ID X 11"LG VENT
40	1	25139	TUBE, 5/8"OD X 3/8"ID X 15"LG DRAIN/FILL
41	1	86016	WORM DRIVE CLAMP 7/16" - 25/32"
42	1	44004	LABEL GROUND
43	1	86030	CLAMP, 3/4" MAX TUBE OD FLOW CONTROL
44	1	44048	WARNING LABEL
45	11	84050	NUT, CLIP ON (J-NUT), #6-32, 22 - 20 GA., BLACK-PHOSPHATE FINISH
46	1	002159	WELDMENT COVER RIGHT CBS-2040e'S
47	1	46027	LABEL, SPRAY HOUSING
48	11	82053	SCREW, # 6-32 X 1/2" TRUSS HD PH
49	1	101266	ASSEMBLY, BREW BASKET, 13 X 5, DIA HOLE 0.218", 0.25" FLG (SEE FIG. 9)
50	1	63019	CORD, 120 VAC, 12/3 AWG .20 AMP , W/5-20P NEMA PLUG
51	1	44050	LABEL, WARNING, "HOT WATER FAUCET"
52	1	46068	LABEL, CONTROL PANEL, CBS2030/40ee

**Figure 6 – CBS-2041ee Tank Assembly, Part # 104097**

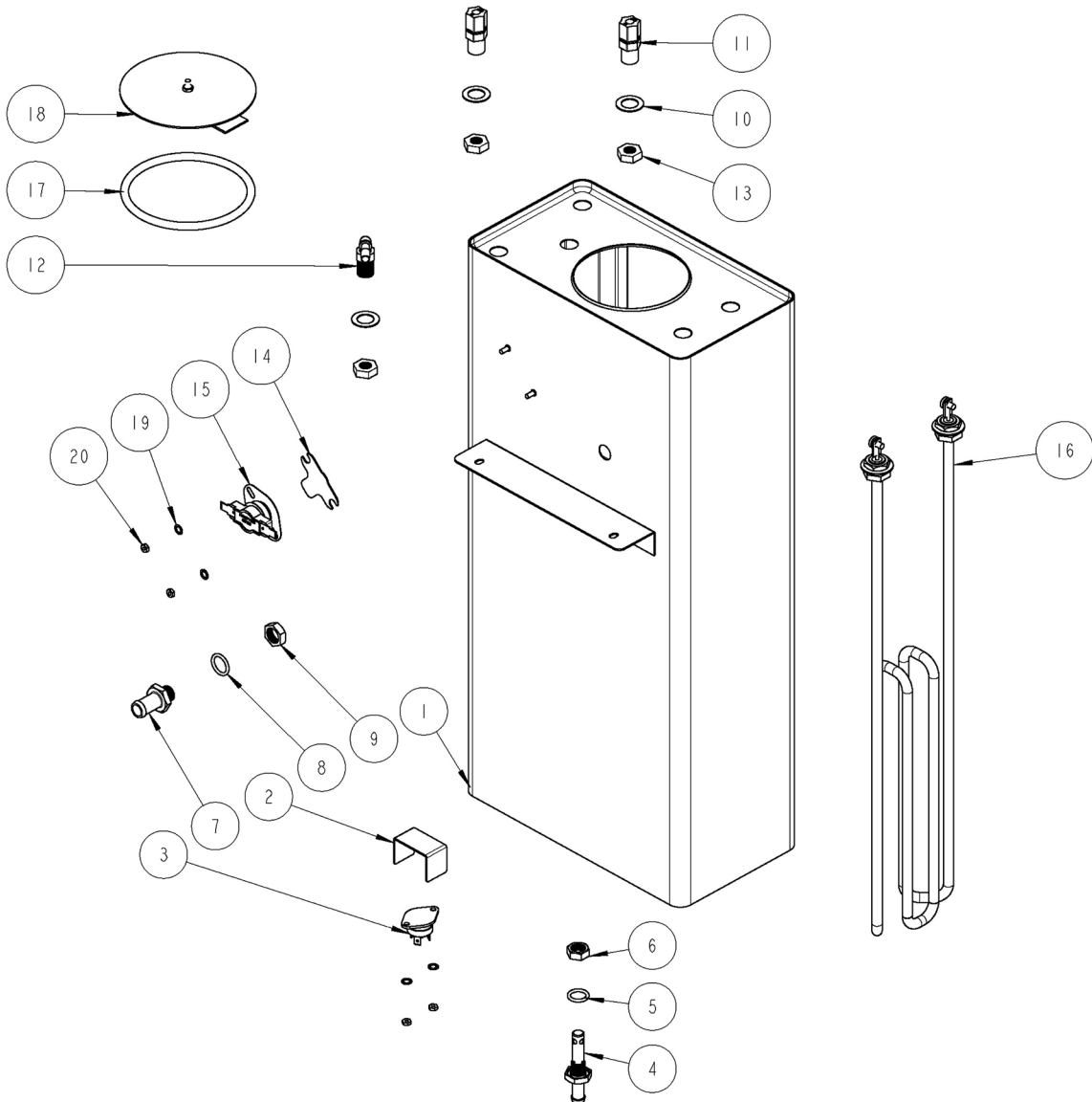

DWG 104097-A

ITEM #	QTY	PART #	DESCRIPTION
1	1	004091	WELDMENT TANK CBS-2041ee, O-RING FITTINGS
2	1	03297	SINK, HEAT FOR 40A TRIAC
3	1	59008	TRIAC 40A, 600V
4	1	13139	FITTING 3/8" HOSE ID WATER INLET/DRAIN
5	1	24099	O-RING, 1/2 X 11/16, 3/32 WIDTH
6	1	13134	NUT FOR 3/8 HOSE ID FITTING
7	1	13137	FITTING 1/2" HOSE ID
8	1	24098	O-RING 9/16 X 3/4, 3/32 WIDTH
9	1	13135	NUT FOR 1/2 HOSE ID FITTING
10	3	83084	WASHER .875"OD X .536"ID, FLA, 22 GA
11	2	25098	FITTING, COMPRESSION MALE CONNECTOR
12	1	25128	FITTING, 90 DEG. ELBOW, 1/4 NPT X 5/16 BARB, KYNAR
13	3	23249	LOCKNUT 1/4"-18 NPT MODIFIED THREAD
14	1	03332	BRACKET 2, ONE SHOT THERMOSTAT
15	1	53071	THERMOSTAT, SINGLE SHOT, 25A
16	1	107024	ASSEMBLY,IMMERSION HEATER,2300W, 120VAC
17	1	24002	O-RING, TANK COVER
18	1	102013	ASSEMBLY, TANK COVER
19	4	83011	WASHER, #6 SCREW SIZE, INTERNAL
20	4	84045	NUT, HEX 6-32, UNDERSIZED

Figure 7 – CBS-2042ee Main Assembly

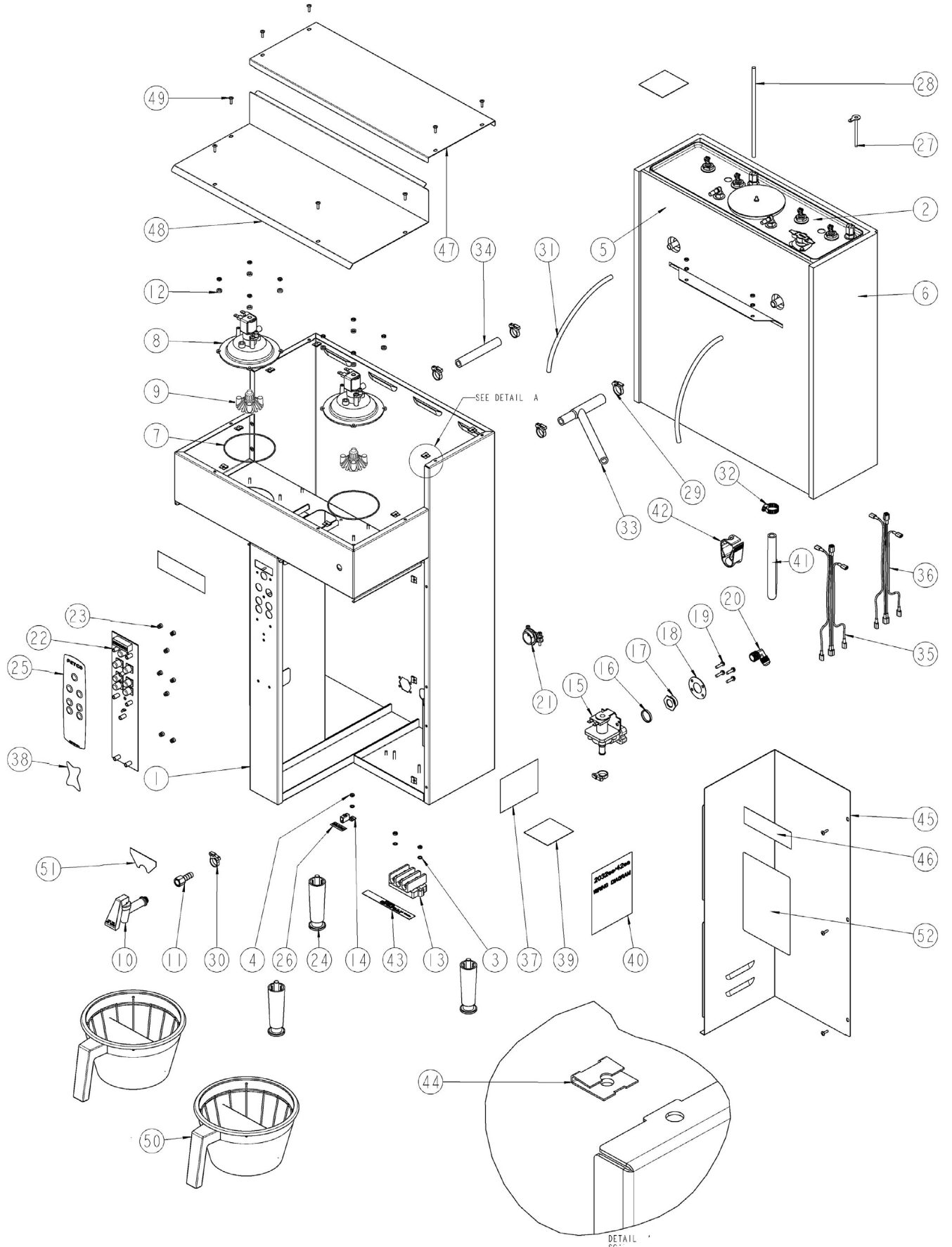

ITEM #	QTY	PART #	DESCRIPTION
1	1	001085	WELDMENT CBS-2042ee
2	1	104096	ASSEMBLY TANK, CBS-2042ee (SEE FIG. 8)
3	5	83026	WASHER, INTERNAL TOOTH LOCK, #8 SCREW SIZE
4	13	84002	NUT, HEX, #8-32 MACHINE SCREW
5	1	22127	INSULATION, TANK FRONT, CBS-2042ee,
6	1	22067	INSULATION, TANK BACK CBS-2042e
7	2	24101	O'RING, 3.739" ID X 0.070" CS, 70 DURO, BUNA "N", FDA
8	2	102357	ASSEMBLY, HOUSING SPRAY W/VALVE 120 VAC, CSD Ø 3.6" (SEE FIG. 10)
9	2	102363	ASSEMBLY, CASCADE SPRAY DOME, "EE"
10	1	71021	FAUCET, COMPLETE, HOT WATER, RED SAFETY HANDLE
10	1	71023	FAUCET UPPER ASSY., HOT WATER, RED SAFETY HANDLE
10	1	71003	FAUCET SEAT CUP, HOT WATER
11	1	31075	FITTING, 3/8"ID x 1/4" FPT
12	8	83076	WASHER,#8 SCREW SIZE, CUSHION AND SEALING
13	1	52090	TERMINAL BLOCK, 3 POLE, W/ MARKING STRIP
14	1	65002	CONNECTOR, COPPER LUG
15	1	57006	VALVE, S-53 120VAC
16	1	24012	GASKET, S-53 FILL VALVE
17	1	31078	FITTING, S-53 FILL VALVE INLET
18	1	03074	BRACKET, S-53
19	4	82020	SCREW, S-53 FILL VALVE
20	1	31031	FITTING, 90 MALE ELBOW, 3/8 TUBE OD X 3/8 MPT
21	1	86040	CONNECTOR, CABLE CLAMP, 3/4"
22	1	51090	BOARD, SWITCHING/CONTROL, 100-120VAC (DUAL)
23	8	29007	NUT, #4-40 KNURLED THUMB
24	3	73002	LEG, FLANGE FOOT, 4" HIGH
25	1	45100	OVERLAY CBS-2042ee
26	1	44004	LABEL GROUND
27	1	K029	WATER LEVEL PROBE REPLACEMENT, CBS-2040'S/50'S
28	1	54022	PROBE, TEMPERATURE 8" LONG, 50k
29	1	86038	CLAMP, HOSE, .670"-.780" DIA RANGE
30	5	86007	CLAMP, HOSE, .593"-.656" DIA RANGE
31	2	25137	TUBE, 5/16"OD X 3/16"ID X 11"LG VENT
32	1	86016	WORM DRIVE CLAMP 7/16" - 25/32"
33	1	24102	MANIFOLD TEE, REDUCING, WATER DISTRIBUTION, SILICONE
34	1	25140	TUBE, 5/8"OD X 3/8"ID X 4.25"LG BREW
35	1	402096	HARNESS, LOW AMP, CBS-2032ee/42ee
36	1	402097	HARNESS, HIGH AMP, CBS-2032ee/42ee
38	1	41016	LABEL, EXTRACTOR
39	2	44024	LABEL, WARNING-HIGH VOLTAGE
40	1	401348	WIRING DIAGRAM, CBS-2032ee/42ee
41	1	25139	TUBE, 5/8"OD X 3/8"ID X 15"LG DRAIN/FILL
42	1	86030	CLAMP, 3/4" MAX TUBE OD FLOW CONTROL
43	1	44048	WARNING LABEL
44	11	84050	NUT, CLIP ON (J-NUT), #6-32, 22 - 20 GA., BLACK-PHOSPHATE FINISH
45	1	02159	WELDMENT COVER RIGHT CBS-2040e'S
46	2	46027	LABEL, SPRAY HOUSING
47	1	01479	COVER, TOP CBS-2032 & 42
48	1	01522	COVER, UPPER BASE CBS-2042
49	11	82053	SCREW, # 6-32 X 1/2" TRUSS HD PH
50	2	101266	ASSEMBLY, BREW BASKET, 13 X 5, DIA HOLE 0.218", 0.25" FLG (SEE FIG. 9)
51	1	44050	LABEL, WARNING, "HOT WATER FAUCET"
52	1	46068	LABEL, CONTROL PANEL, CBS2030/40ee

**Figure 8 – CBS-2042ee Tank Assembly, Part # 104096**

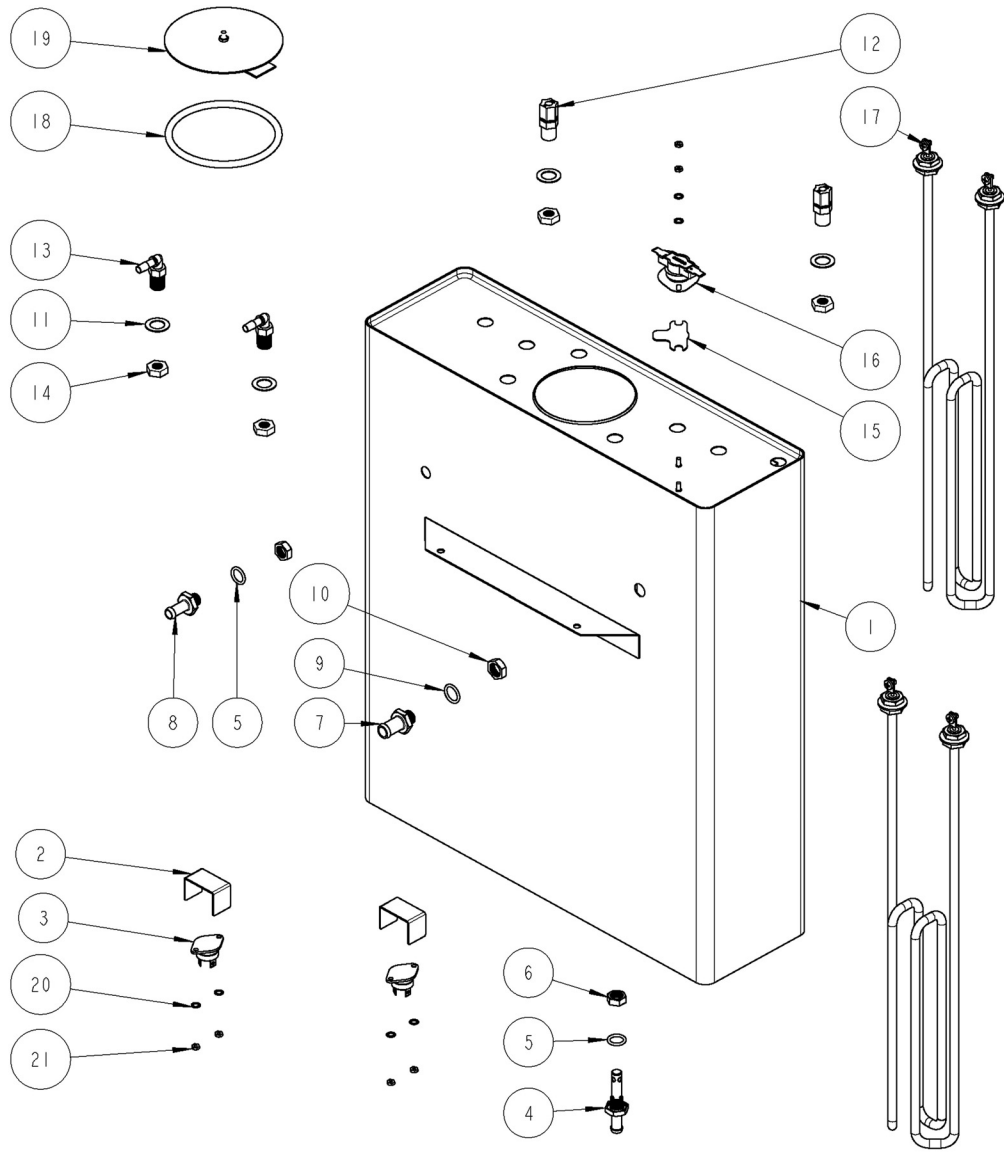

DWG 104096-A

ITEM #	QTY	PART #	DESCRIPTION
1	1	004090	WELDMENT TANK CBS-2042ee, O-RING FITTINGS
2	2	03297	SINK, HEAT FOR 40A TRIAC
3	2	59008	TRIAC 40A, 600V
4	1	13139	FITTING 3/8" HOSE ID WATER INLET/DRAIN
5	2	24099	O-RING, 1/2 X 11/16, 3/32 WIDTH
6	2	13134	NUT FOR 3/8 HOSE ID FITTING
7	1	13137	FITTING 1/2" HOSE ID
8	1	13138	FITTING 3/8" HOSE ID
9	1	24098	O-RING 9/16 X 3/4, 3/32 WIDTH
10	1	13135	NUT FOR 1/2 HOSE ID FITTING
11	4	83084	WASHER .875"OD X .536"ID, FLA, 22 GA
12	2	25098	FITTING, COMPRESSION MALE CONNECTOR
13	2	25128	FITTING, 90 DEG. ELBOW, 1/4 NPT X 5/16 BARB, KYNAR
14	4	23249	LOCKNUT 1/4"-18 NPT MODIFIED THREAD
15	1	03332	BRACKET 2, ONE SHOT THERMOSTAT
16	1	53088	THERMOSTAT, SINGLE SHOT, 240V/40A
17	2	107002	ASSEMBLY, IMMERSION HEATER, 3000W, 240VAC
18	1	24002	O-RING, TANK COVER
19	1	102013	ASSEMBLY, TANK COVER
20	6	83011	WASHER, #6 SCREW SIZE, INTERNAL
21	6	84045	NUT, HEX 6-32, UNDERSIZED

**Figure 9 – Brew Basket Assembly, 13” X 5”, Part # 101266**

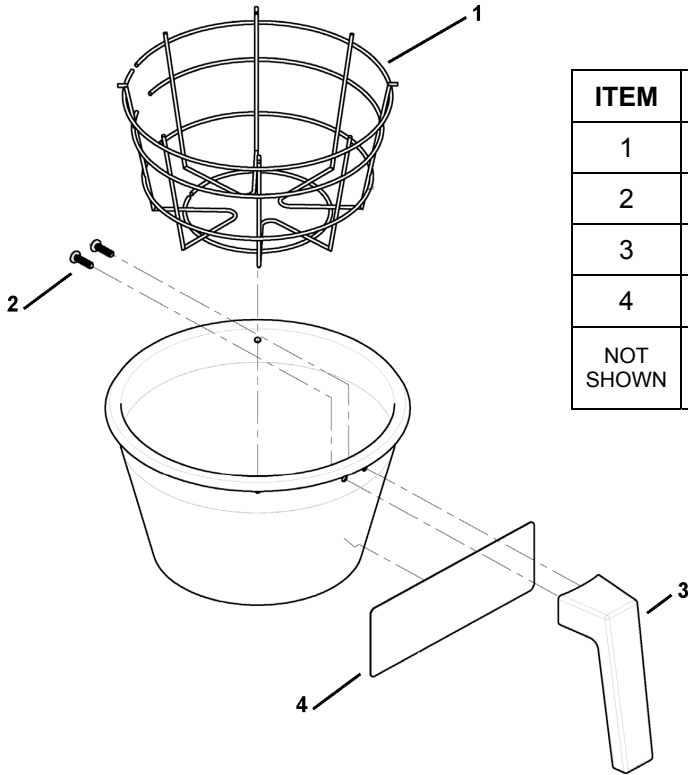

ITEM	QTY	PART #	DESCRIPTION
1	1	09021	WIRE INSERT, 13 X 5
2	2	82118	HANDLE SCREW
3	1	23074	BREW BASKET HANDLE, BLACK
4	1	46011	WARNING LABEL
NOT SHOWN		F002	PAPER FILTERS, 13” X 5” 500 PER CASE

**COLOR BREW BASKET HANDLES**

PART #	DESCRIPTION
23169	BREW BASKET HANDLE, RED
23171	BREW BASKET HANDLE, GREEN

**Figure 10 – ASSEMBLY, HOUSING SPRAY W/VALVE 120 VAC, CSD Ø 3.6", Part # 102357**

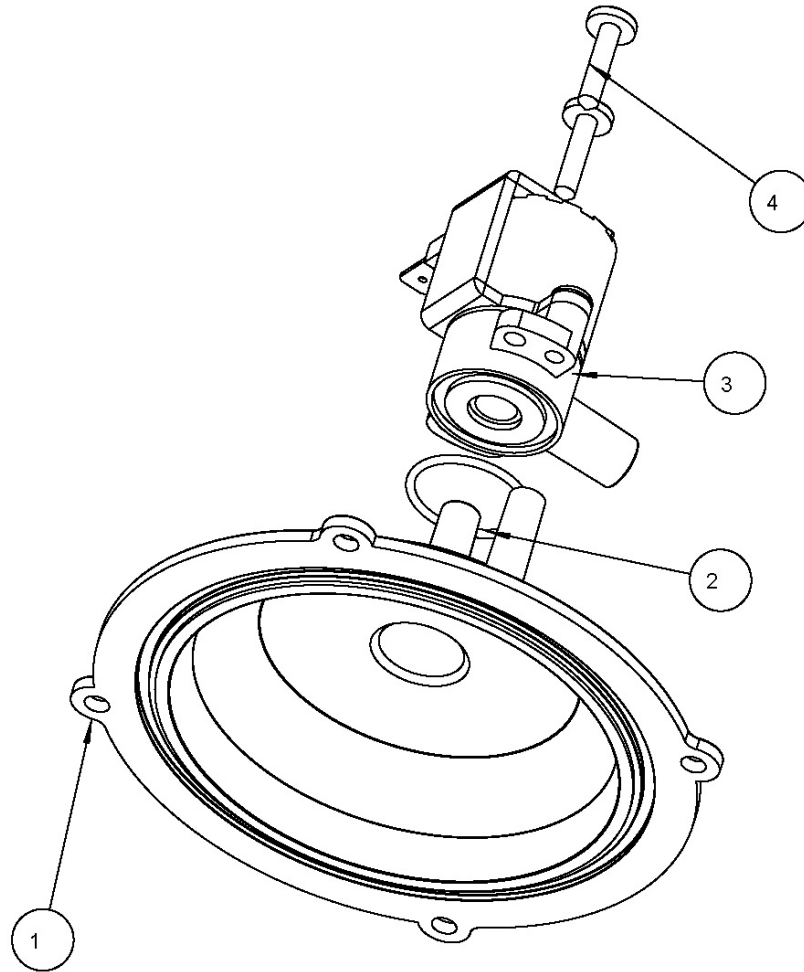

ITEM	QTY	PART #	DESCRIPTION
1	1	102378	ASSEMBLY, HOUSING SPRAY, W/MAGNETS, CSD, DIA 3.6"
2	1	24075	O RING, .801 ID X 1/16 CROSS SEC
3	1	102214	ASSEMBLY, DISPENSE VALVE, RPE, 120V/60Hz
4	2	82104	SCREW, PAN HD #7 x 3/4 LG, SHEET METAL

