

E3265
REV P 6/8/20



The Signature of Quality®

IMSS60, IMSS84, IMSS120, EIMSS60 & EIMSS84 MODELS INSTALLATION & OPERATIONS MANUAL



KEEP THIS MANUAL FOR FUTURE REFERENCE

Engineering and technical data are subject to change without notice.

FEDERAL INDUSTRIES
Toll Free 1(800) 356-4206

215 Federal Ave.
WI Phone (608) 424-3331

Belleville, WI 53508
Fax: (608) 424-3234

IMSS E3265

CONTENTS

| | |
|---|--------------|
| INTRODUCTION..... | 3 |
| WARNING LABELS & SAFETY INSTRUCTIONS | 4 |
| PRE-INSTALLATION PROCEDURES | 5 |
| INSPECTION FOR SHIPPING DAMAGE | 5 |
| INSTALLATION INSTRUCTIONS..... | 5-8 |
| LOCATING THE DISPLAY CASE | 5 |
| ELECTRICAL CONNECTION | 5-6 |
| PERMANENT CONNECTED..... | 5 |
| STANDARD BASE ELECTRICAL CONNECTION | 5-6 |
| TOP ELECTRICAL CONNECTION..... | 6 |
| CORD CONNECTED | 6 |
| REMOVING CASE FROM SHIPPING SKID | 7 |
| REMOVING PACKAGING MATERIAL | 7 |
| LEVELING THE CASE..... | 7 |
| SEALING THE UNIT TO THE FLOOR | 7 |
| BASE PANELS REMOVAL IMSS60 & IMSS84..... | 8 |
| BASE PANELS REMOVAL IMSS120 | 9 |
| BASE COMPONENT LAYOUT | 10-13 |
| CONDENSATE EVAPORATOR | 14 |
| CONDENSATE PAN SHIPPED LOOSE..... | 14 |
| CONDENSATE PUMP | 15 |
| SHELVES | 16-17 |
| OPERATING INSTRUCTIONS..... | 18-21 |
| USER CONTROLS | 18 |
| POWER SWITCH | 18 |
| LIGHT SWITCH | 18 |
| ELECTRONIC CONTROL | 18-21 |
| INITIAL START UP | 21 |
| PLACING PRODUCT IN CASE | 21 |
| CLEANING INSTRUCTIONS..... | 21-24 |
| ACRYLIC AIR DEFLECTOR | 21 |
| DAILY CLEANING..... | 22 |
| WEEKLY CLEANING | 22-23 |
| MAINTENANCE | 24 |
| CLEANING CONDENSER COIL..... | 24 |
| SERVICE INFORMATION | 25 |
| PRE-SERVICE CHECKLIST | 26 |
| SPECIAL SERVICE SITUATIONS | 27 |
| SALE & DISPOSAL..... | 27 |
| ELECTRICAL DATA..... | 28 |
| CONTROL OPERATION | 29 |
| ELECTRONIC CONTROL | 29 |
| OPERATION | 29 |
| DEFROST CYCLE..... | 29 |
| MAXIMUM RUN TIMER | 29 |
| CONTROL PARAMETERS | 30-32 |
| REFRIGERATION OPERATION | 33-35 |
| SELF CONTAINED OPERATION | 33 |
| REMOTE OPERATION..... | 33-34 |
| ELECTRONIC EXPANSION VALVE (EEV)..... | 35 |
| REPLACEMENT PARTS - | 36-37 |
| WIRING DRAWING | 38-68 |

INTRODUCTION

Thank you for purchasing a Federal Industries Merchandiser. This manual contains important instructions for installing and servicing the RSSM, Refrigerated Self-Service Merchandisers. A repair parts list is also included in the manual. Read all of these documents carefully before installing or servicing your case.



NOTICE

Read this manual before installing your case. Keep this manual and refer to it before doing any service on the equipment. Failure to do so could result in personal injury or damage to the case.



NOTICE

Installation and service of the electrical components in the case must be performed by a licensed electrician.

The portions of this manual covering components contain technical instructions intended only for persons qualified to perform electrical work.



DANGER

Improper or faulty hookup of electrical components in the case can result in severe injury or death.

All electrical wiring hookups must be done in accordance with all applicable local, regional, or national standards.

NOTE: UNIT MUST BE GROUNDED

REGISTRATION & SERIAL NUMBER

It's important to keep a record of the model and serial number of your merchandiser for warranty and part identification. Please write them here for your quick reference.

Register your product online! Visit our website at www.federalindustries.com and register your product today.

Case Model _____ Serial Number _____

We're here to provide you with the best possible experience with your new product, however, we cannot cover everything about your merchandiser in this manual, so if you have any additional questions or issues, please see the SERVICE INFORMATION PAGE to find who you should contact.

WARNING LABELS & SAFETY INSTRUCTIONS



This is the safety-alert symbol. When you see this symbol on your case or in the manual, be alert to the potential for personal injury or damage to your equipment.

Be sure you understand all safety messages and always follow recommended precautions and safe operating procedures.



NOTICE TO EMPLOYERS

You must make sure that everyone who installs, uses, or services your case is thoroughly familiar with all safety information and procedures.

Important safety information is presented in this section and throughout the manual. The following signal words are used in the warning and safety messages:

- DANGER:** Severe injury or death will occur if you ignore the message.
- WARNING:** Severe injury or death can occur if you ignore the message.
- CAUTION:** Minor injury or damage to your case can occur if you ignore the message.
- NOTICE:** This is important installation, operation, or service information. If you ignore the message, you may damage your case.

The warning and safety labels shown throughout this manual are placed on your Federal Industries case at the factory. Follow all warning label instructions. If any warning or safety labels become lost or damaged, call our customer service department at 1(800) 356-4206 for replacements.

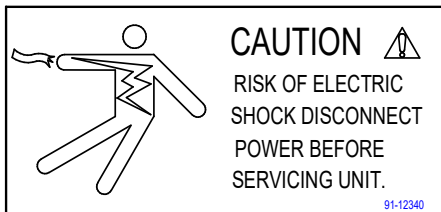

This label is located behind the removable base and under the display deck pans.

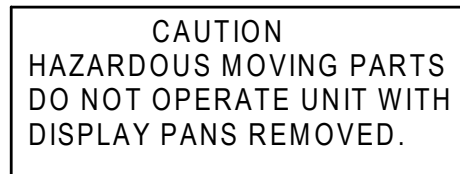

This label is located below panels display deck pans.

PRE-INSTALLATION PROCEDURES

Inspection For Shipping Damage

You are responsible for filing all freight claims with the delivering truck line. Inspect all cartons and crates for damage as soon as they arrive. If damage is noted to shipping crates, cartons, or if a shortage is found, note this on the bill of lading (all copies) prior to signing.

If damage is discovered when the case is uncrated, immediately call the delivering truck line and follow-up the call with a written report indicating concealed damage to your shipment. Ask for an immediate inspection of your concealed damaged item. Crating material must be retained to show the inspector from the truck line.

INSTALLATION INSTRUCTIONS

Locating The Display Case

The case should be located where it is not subjected to the direct rays of the sun, heating ducts, grills, radiator, or ceiling fans, nor should it be located near open doors or main door entrances. Also, avoid locations where there is excessive air movement or air disturbances and avoid high humidity locations such as near cases with water misting or fogging devices. Failure to locate this case as stated will reduce the performance of your Island display and will affect temperature of interior of case and product.

The case requires a minimum of 48" of clearance is needed on all sides of unit.

Electrical Connection

(See condensate pan section for special condensate pan wiring)



DANGER: Improper or faulty hookup of electrical components in the display case can result in severe injury or death.

Permanent Connected (Standard)

- Only a licensed electrician must perform all case electrical connections.
- All electrical wiring hookups must be done in accordance with all applicable local, regional, or national electrical standards.
- A separate circuit for each display case is required to prevent other appliances on the same circuit from overloading the circuit and causing malfunction.
- The electrical service must be grounded upon installation.
- See the electrical data plate located on the base end, for proper circuit size and wire ampacity.

Standard Base Electrical Connection: There are (2) different styles of electrical box connections as shown in pictures below. The electrical connection box is in the base for floor electrical connection. The box is accessible by removing the base panel. See “Panel Removal Section” of this manual for panel removal instructions. Remove electrical box cover to access electrical connection.

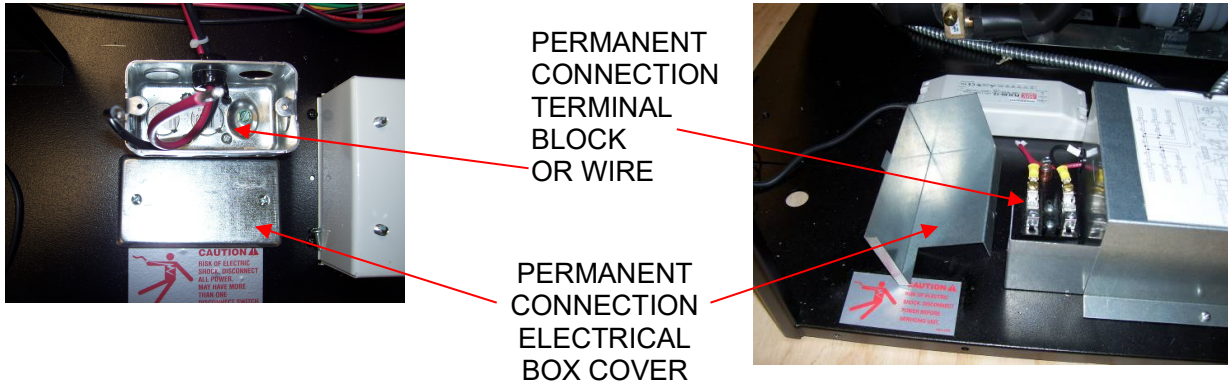

Optional Top Electrical Connection: The electrical connection box is accessible on the top of the case for ceiling drop electrical connection. Remove electrical box cover to access electrical connection.

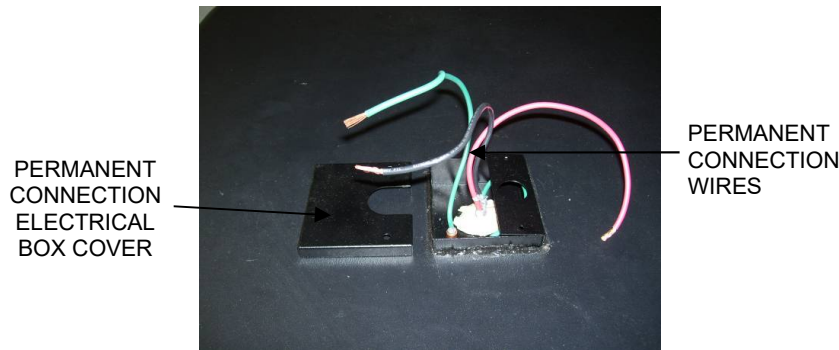

Cord Connected (OPTION)

- A factory installed optional power cord is properly sized to the amperage requirements of the case. See the electrical data plate located on the rear exterior of the case for the proper circuit size for each case.
- The cord is factory installed protruding from the corner of the case.
- A separate circuit for each display case is required to prevent other appliances on the same circuit from overloading the circuit and causing malfunction.

CAUTION Risk of Electric Shock. If the cord or plug becomes damaged, replace only with a cord and plug of the same type".



Removing Case From Shipping Skid

CAUTION: Do not push against the clear acrylic deflector around the sides and nose.
Doing so can cause the acrylic to break.
Do not lift or push on the top canopy located on top of the case.
Doing so can permanently damage the tower frame.
Care must be taken not to damage or tip the case when removing it from the skid or moving the case.

Remove the screws and brackets that secure the case to the skid. Remove the brackets from the case.

Note that the case may have optional wheels installed and once the brackets holding the case to the skid are removed the case will roll.



Removing Packaging Material

Remove bubble wrap and packing material for all shelves and panel, brackets, etc. If it is necessary to remove tape residue from plastic materials, use cleaning compounds recommended in the cleaning section of this manual.

Leveling The Case

The case must be level for proper drainage of defrost water to the condensate pump. A wrench is included to aid in adjusting leg levelers

Check the level of the case where the display overhangs the base.

Adjust the (4) outside leg levelers as needed to **level** the case in each direction.

The IMSS120 has (2) center leg levelers adjust these so that the center of base floor is flat.

NOTE: Use a wood or plastic shim under each leg leveler to avoid scratching the tile floor.

Sealing Unit To The Floor

After the unit is positioned and the leg levelers are turned out, the unit needs to be sealed to the floor for NSF approved installation.

Base Panel Removal IMSS60 and IMSS84 Panels



DANGER: Electric shock hazard. Do not operate unit with panels removed.

Panels must be in place when operating the case.

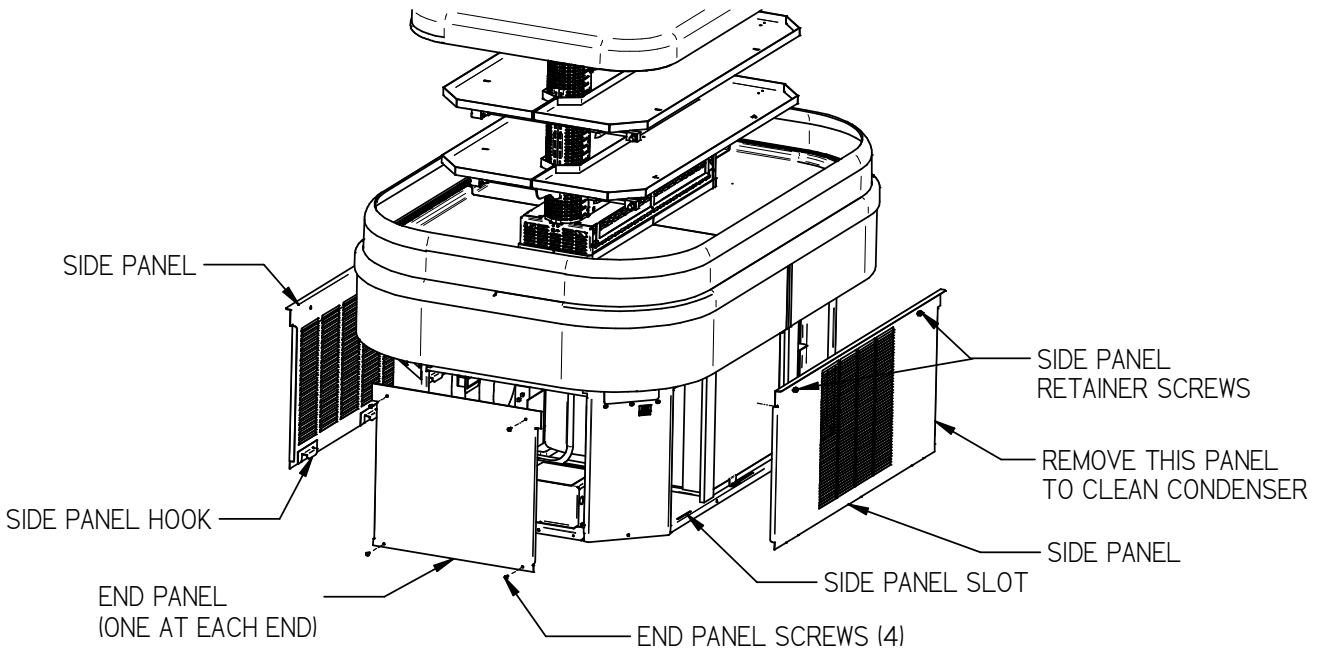

Side Panels

1. Loosen the 2 retainer screws from top of panel.
(The screws will stay on the panel even after they are detached from base)
2. Tilt the top of the panel away from the base and pull up on panel to allow the side panel tabs to pull out of the side panel slots.
3. Set the panel in safe place to prevent damage.
4. Reinstall panels in the reverse order.

End Panels

1. Remove the (4) retainer screws from all four corners of end panel.
2. Remove end panel from case and set it in safe place to prevent damage.
3. Reinstall panels in the reverse order.

Base Panel Removal IMSS120 Panels



DANGER: Electric shock hazard. Do not operate unit with panels removed.

Panels must be in place when operating the case.

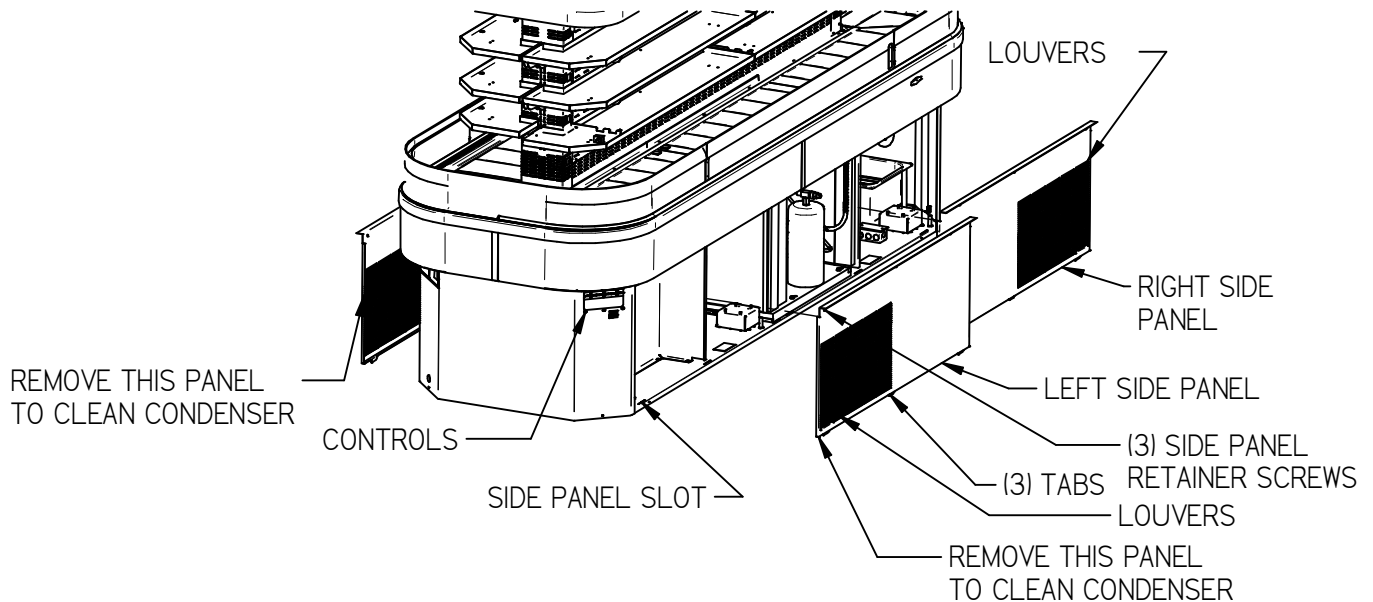

Side Panels

1. Loosen the 3 retainer screws from top of each side panel.
(The screws will stay on the panel even after they are detached from base)
2. Tilt the top of the panel away from the base and pull up on panel to allow the side panel tabs to pull out of the side panel slots.
3. Set the panel in safe place to prevent damage.
4. Reinstall panels in the reverse order.

NOTE: left and right-side panels can only be installed as shown. Louvers must be near the end of case for the tabs to align with side panel slots. Be sure all (3) tabs are engaged into side panel slots.

Base Component Layouts Self Contained IMSS60 & IMSS84

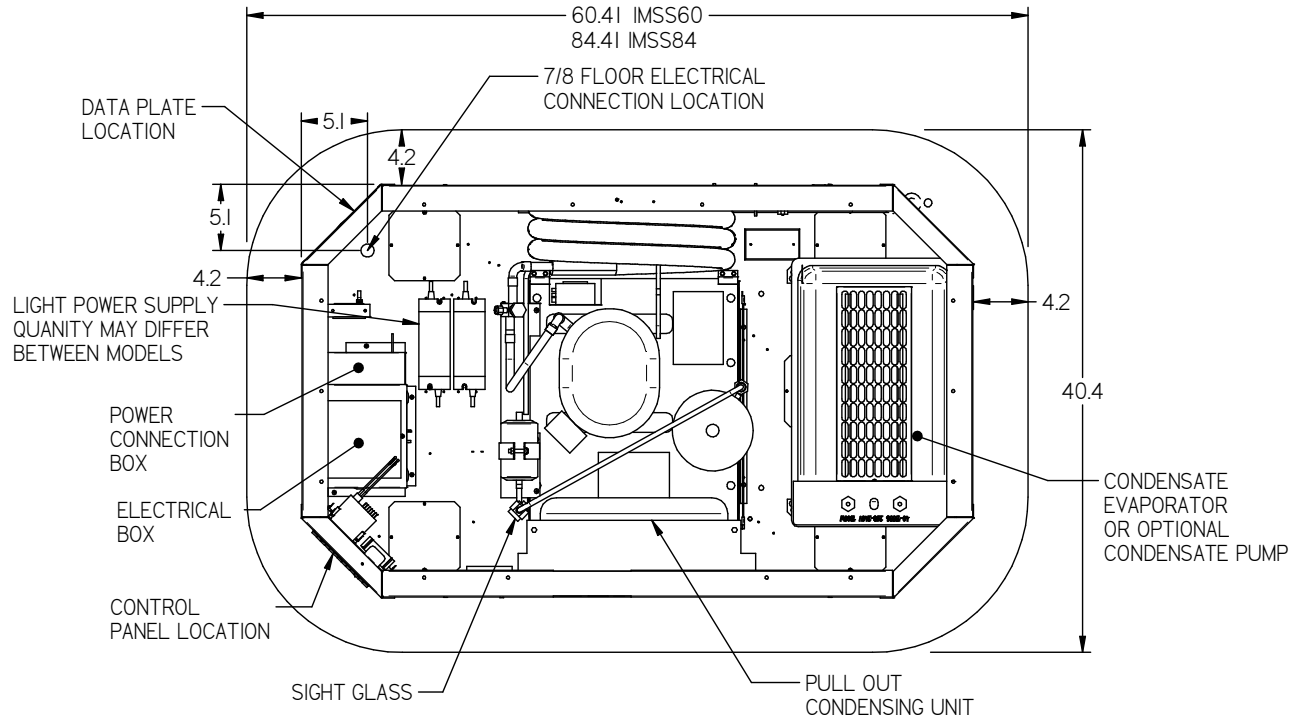

LAYOUT AFTER 12/1/19

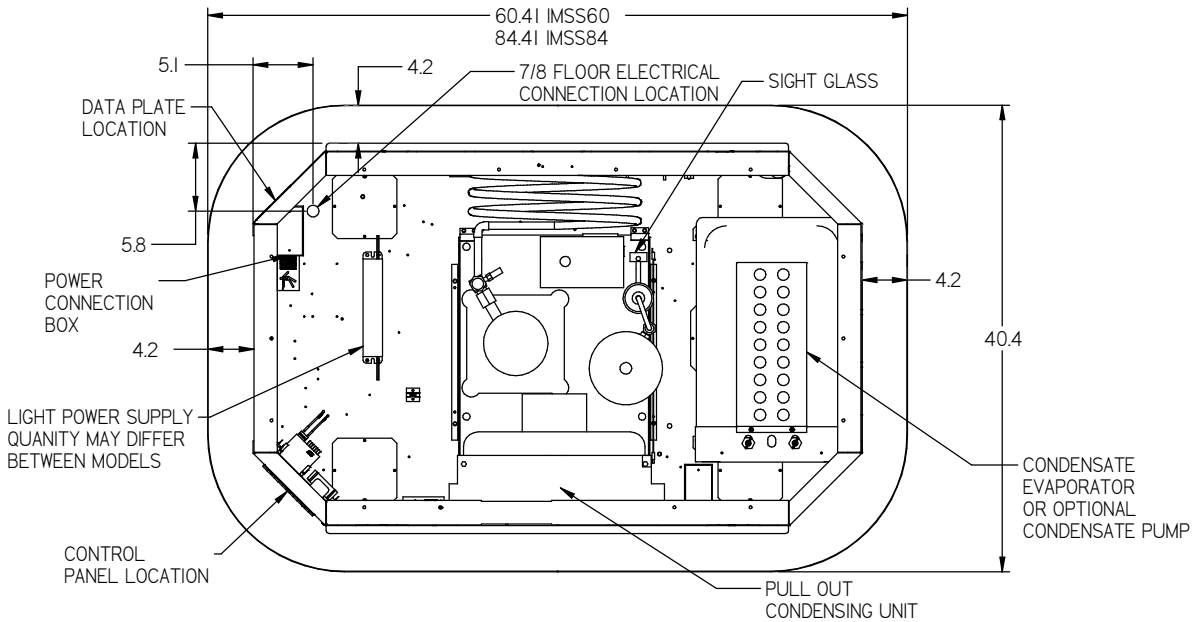

Base Component Layout Remote IMSS60 & IMSS84

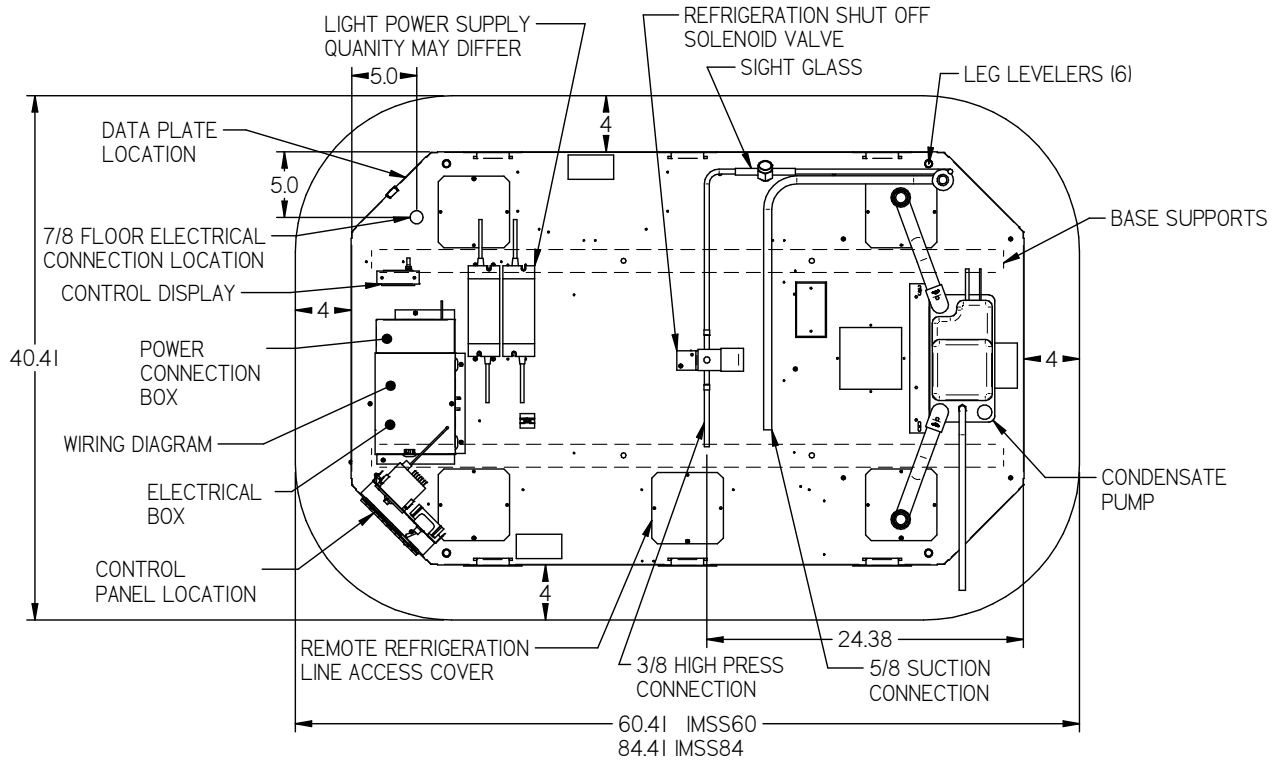

LAYOUT AFTER 12/1/19

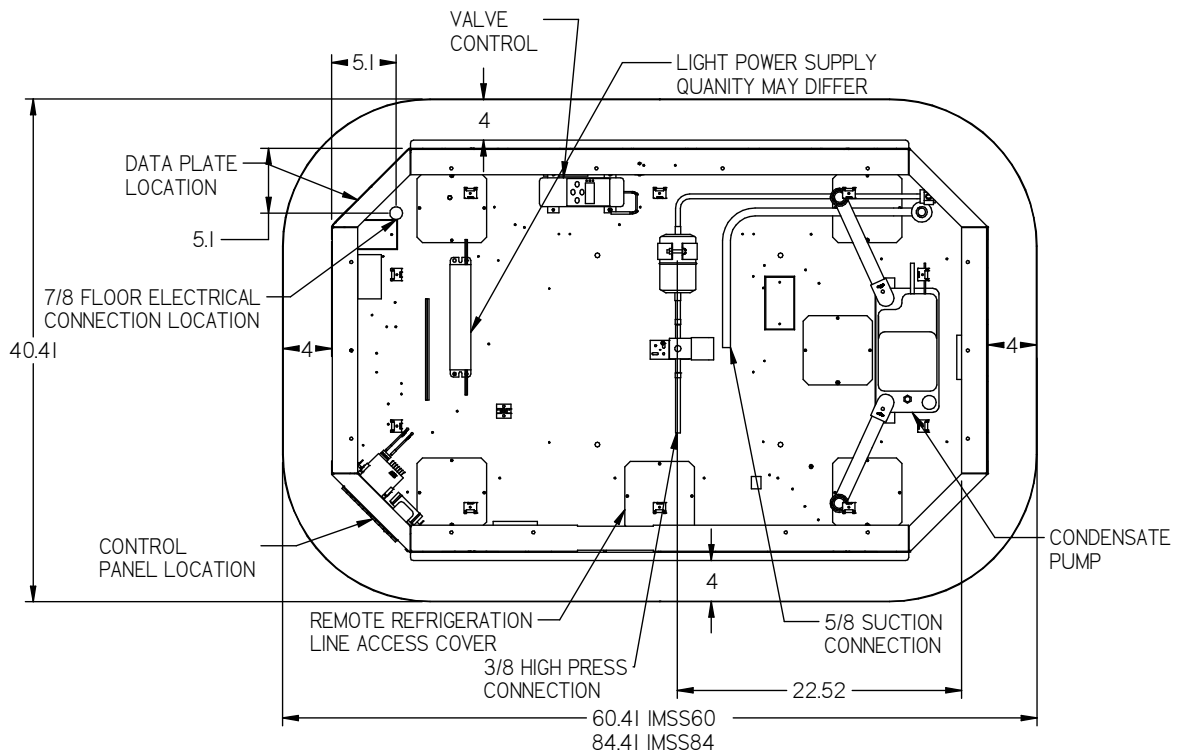

Base Component Layout Self Contained IMSS120

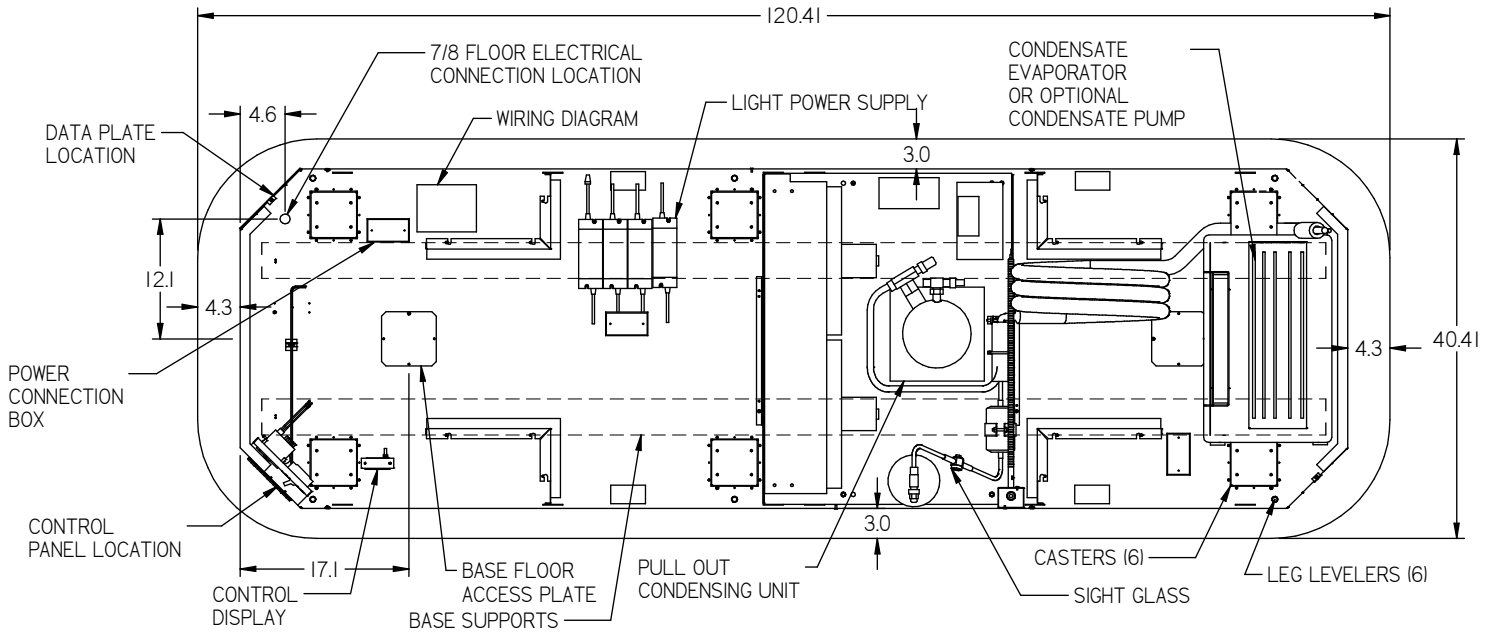

Base Component Layout Remote 120

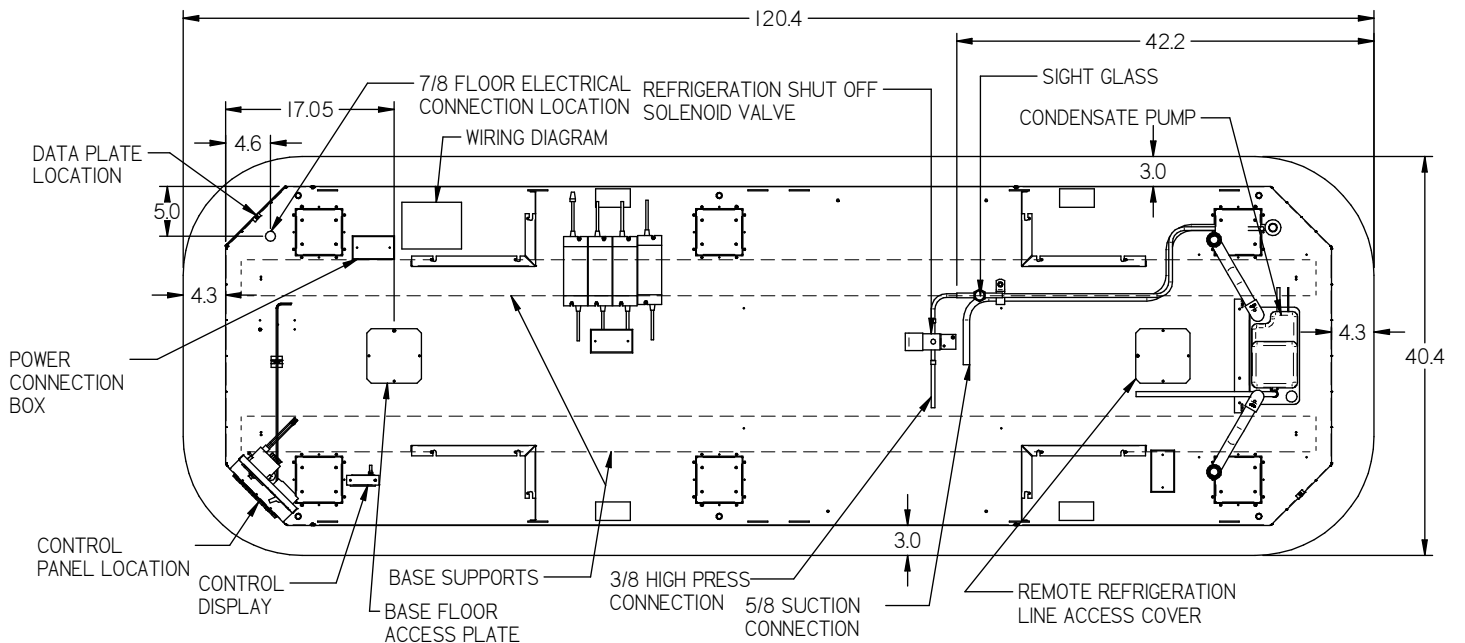

Layout after 12/1/19

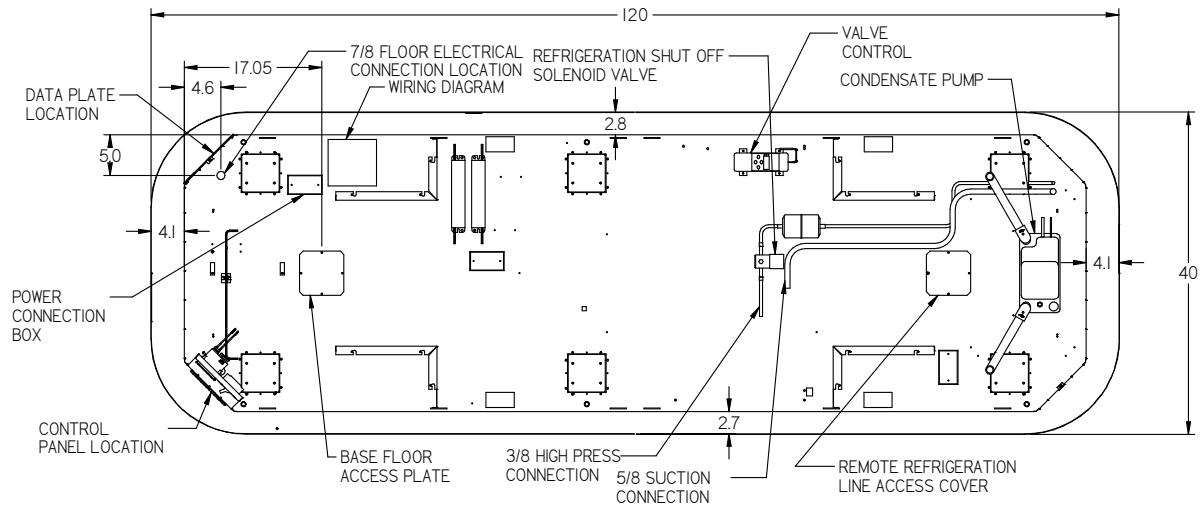

Condensate Evaporator Pan (Standard 3 Shelf Self Contained Models)



The standard Self-Contained case is furnished with an electric condensate evaporator. Plumbing connections are not required.

Make sure that the drain line has not been dislodged during shipment and that the drain trap terminates properly over the water reservoir.

The condensate evaporator can be removed from the case and the drain lines can be plumbed to a drain or a condensate pump to conserve energy. A licensed electrician will need to disconnect the condensate evaporator wires.

Condensate Evaporator Pan Shipped Loose (OPTION)

If the optional high output condensate pan was ordered it will be shipped loose in a separate box. This high output pan must be field mounted and wired by a licensed electrician.

If there is already a factory condensate pan and mounting brackets installed in the base compartment they must be removed before installing the optional high output pan.

Unwire the heater wires from the 2x 4 electrical box and cap remaining wire ends with UL approved wire nuts. NOTE: THESE WIRES CAN NOT BE CONNECTED TO THE FIELD INSTALLED HIGH OUTPUT PAN.

Mount the high output condensate pan inside the base compartment so that the (2) condensate drain tubes drain directly into the pan as shown in photo.

The field installed high output condensate pan must be wired to its own designated circuit breaker and **cannot** be wired into the same circuit breaker that the display case uses. The display case circuit and wiring are not sized to handle the extra amperage of the high output condensate pan. See label on condo pan for proper circuit sizing.

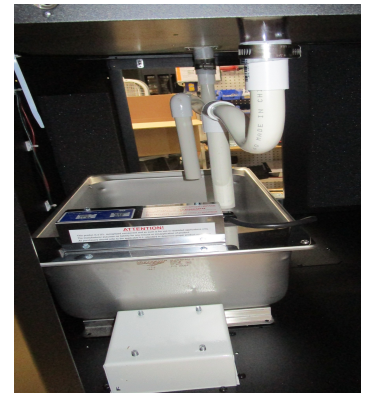

- Bottom Electrical (standard): There is cord and plug provided on the high output condensate pan. a licensed electrician must provide a designated receptacle to plug in the high output condensate pan. There are access holes in various locations in the base enclosure to run wires out of the case to electrical source.

-Top Electrical (optional): There is also a top wiring condensate pan option that provides a top electrical box on the top side of the canopy. This allows wires to be run to the store ceiling. There are (2) sets of wires, "main case wiring" and "condensate pan wiring". Each circuit is labeled and must run to separate circuits. The condensates pan wires run down through the case into a 2 x 4 electrical box in the base compartment. A licensed electrician will need to provide a designated receptacle to plug in the high output condensate pan.

Condensate Pump Standard - Remote & 2 Shelf Self-Contained
Optional - 3 Shelf Self Contained

The pump is mounted in the base compartment and is designed to automatically remove the condensate water that collects from defrosting the evaporator coil. The pump has a built-in tank that collects water from the evaporator coil defrost cycle. When the pump tank is full the pump switches on and pumps water to a remote location for disposal. When the tank is empty the pump automatically switches off. The pump is capable of lifting water to a maximum of 20'.

Condensate Discharge Hose.

The case is provided with a 25' of 3/8ID clear flexible tubing. Depending on options it is either coiled up on top of the case or in the base compartment.

Hose Coiled in Base

Disconnect Power: Access the hose located in base compartment by removing one of the base side panels. The hose can be routed to the nearest remote drain through one of the provided openings or holes Do not run hose in heavy traffic areas and be sure hose does not get kinked or pinched.

Hose Coiled on Top

Hose coiled on top of the unit is designed to be run vertical to the ceiling before being routed to the nearest remote drain. The maximum vertical height the hose can run is 20' from floor. Once the hose turns to a horizontal direction the hose must have a downward slope to avoid low spots that water can collect. Be sure the hose does not get kinked or pinched.

Shelves

The IMSS has solid metal shelves with LED lighting as standard.

There are (4) brackets required for each shelf (2 long brackets and (2) short brackets. The long brackets are for the long side of case and the short brackets are at the short end of case. The short bracket with cord retainer clip must be used at the short end of case where the light cord plugs in.

The shelves are adjustable in ~ 1 1/16" increments.

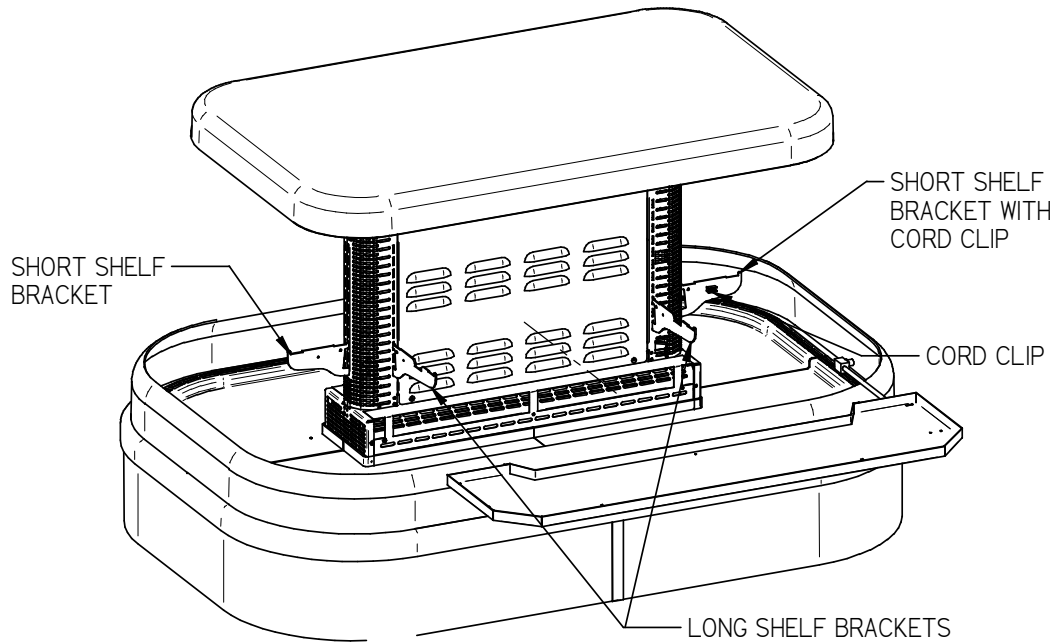

1. Turn the light switch to the off position.
2. Follow the instruction in the illustration below and insert (1) of the (4) shelf brackets in the desired tower slot on one side of the case. Place the additional shelf brackets in the same height level on the opposite end of case. The (2) short brackets must go on the short end and (2) long brackets must go on the long end. The short bracket with a shelf light cord retainer clip must be on the side with the shelf light receptacle.

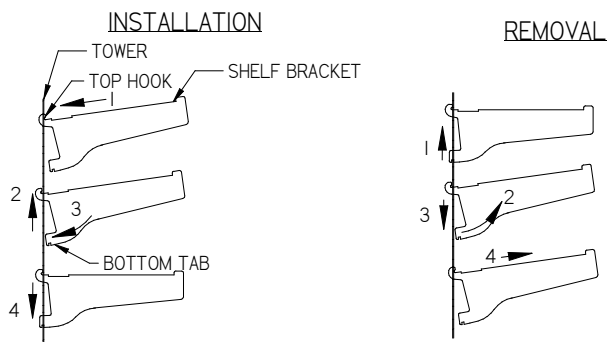

1. Place shelf bracket top hook into desired slot in the tower.
2. Lift shelf bracket top hook to allow shelf bracket bottom tab to clear slot in tower.
3. Swing shelf bracket bottom tab into tower slot.
4. Place the shelf bracket notch onto bottom of tower slot.

1. Lift shelf bracket up to allow shelf bracket notch to clear the bottom of slot in tower.
2. Swing shelf bracket bottom tab out of slot in tower.
3. Drop shelf bracket down to allow shelf bracket top hook to clear the slot in tower.
4. Remove shelf bracket top from slot in tower.

3. Set the shelf on to the brackets and place the bracket retainer clip into slots on shelf.
4. Push shelf light cords into plastic shelf cord retainer clip located on inside of shelf bracket.
5. Remove the cap from the appropriate female light sockets.
6. If the socket is not being used for a shelf light, the cap must be plugged into socket to prevent contamination and moisture out of the socket.
7. Plug in each shelf light by aligning the male pins on the appropriate shelf light cord plugs with the female light sockets and push together. **IMPORTANT:** Do not roll plug during insertion.



8. Place extra cord into cord clip as shown to keep it out of the way.



9. Removal of shelving is performed by following steps in reverse order.

OPERATING INSTRUCTIONS

User Controls

ELECTRONIC CONTROL / DISPLAY

POWER SWITCH

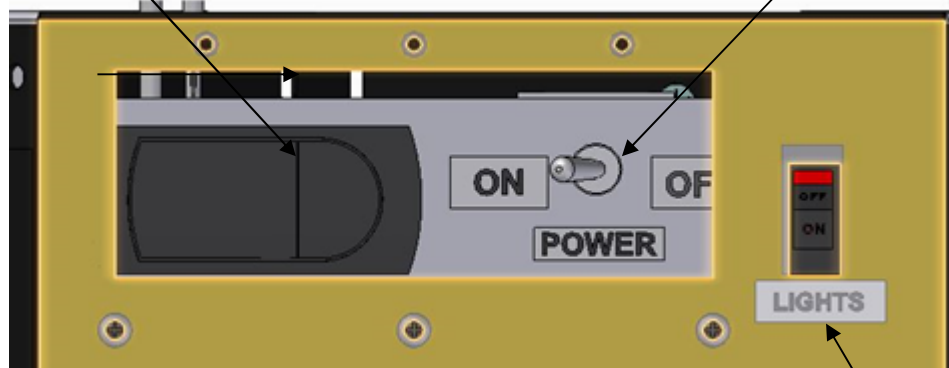

LIGHT SWITCH

Power Switch

The unit has a power switch that turns off power to the entire unit, including the condensate evaporator and the lights. This switch is located behind a lift up panel on the unit base.

Light Switch

The unit has a light switch that turns on and off the interior lights of unit. This switch is located below the lift up panel on the unit base.

Electronic Control

This control is located behind a lift up panel on the unit base.

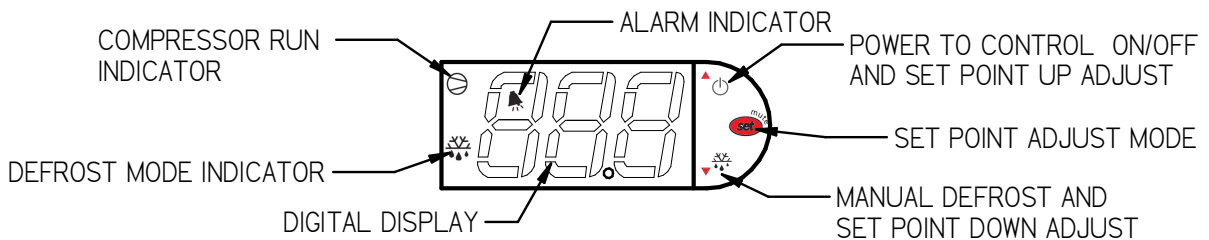

Using Electronic Temperature Control (Refrigerated Models Only)





Button Overview

| | |
|--|--|
| | <p>Press and hold this button for 3 seconds to turn system on (if off) or off (if on). Also used to adjust set point when in set point adjust mode</p> |
| | <p>Press to enter set point adjust mode, confirm set point changes, and mute alarms.</p> |
| | <p>Press and hold this button for 3 seconds to initiate a manual defrost (and cancel defrost if initiated), also adjusts set point down when in set point adjust mode</p> |
| | |





Powering on control

To turn refrigeration control power on, press and hold  for approx. five seconds. The display will read “On” while the button is depressed. When the control powers on, the display will read the current set point numbers 1 thru 9. The compressor run indicator  will illuminate on the display, meaning that the compressor is running. (Note: the control may already be in the on mode when shipped from factory).

To turn refrigeration control power to off, press and hold  for approx. five seconds. The display will read “Off” while the button is depressed. When the control powers off the display will flash back and forth between the current set point and “Off”. The compressor run indicator  will be off on the display. When refrigeration control is in the off-mode cabinet lights and evaporator fans will still operate, but the compressor will not turn on causing the case to gradually reach room temperature.





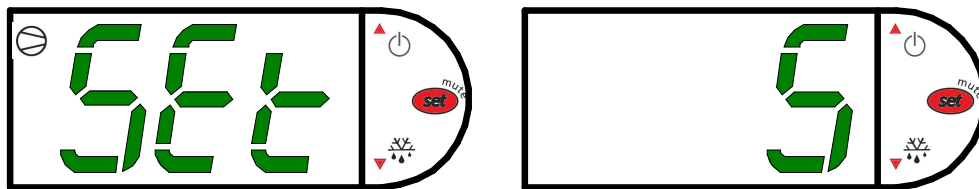

Adjusting the set point

The set point is what determines how cold the display case will hold food and beverage. To adjust the set point press and hold the  button approx. 5 seconds until the display begins to flash a number. Then press the use the  button to scroll number up (colder) or press the  button to scroll number lower (warmer). There are nine (9) available set points numbers, the higher the number of the set point, the colder the display case will run, with setting “9” being the coldest and setting “1” being the warmest. Once you have chosen your desired setting press the  button again to confirm your choice.



Entering manual defrost mode

To initiate a manual defrost press and hold the  button approx. 5 seconds. The control will read “dEF” while the button is being held. The defrost is initiated when the defrost mode indicator  illuminates on the display. The control display will then return to reading the set point. when the defrost mode indicator  turns off the defrost is complete and the compressor will turn back on illuminating the compressor run indicator  .



Error codes

It is possible for error codes to be displayed on the control screen. In the event of a malfunction an alarm will sound and the alarm indicator  will be displayed on the display. An error code or codes will flash intermittently on the display. If there are multiple codes, the display will continuously cycle through them. The following photo shows error code “E0” as an example.



Mute: You may mute the alarm by pressing and releasing the wrench button. The red ringing bell and all error codes will still be displayed. When the fault is remedied the control will return to normal operation and will automatically clear the codes from the display.

Carel Control

E0 = Air sensing probe - Open or shorted

E1 = Evap. coil probe - Open or shorted

| Code | Description | Cause | Resolution |
|------|-----------------------------------|--|---|
| E0 | Temperature probe error | Probe signal is interrupted or short-circuited | Check to ensure probe wires and quick disconnect are secure in control. Check probe resistance to table below. If 0 resistance is present check wiring insulation. If infinite resistance is present check for breaks in wiring (meter will likely read overload or very high in the mega-ohm range). Ensure that probes are wired per the wiring diagram provided. Replace probe if other remedies fail, or if probe resistance deviates from “Table 3” below |
| E1 | Defrost probe error | See E0 | |
| EE | Unit parameter reading error | Operating conditions | Remedy abnormal operating conditions. The control is rated to operate in a range of 14 to 122°F (-10 to 50°C) and less than 90%RH non-condensing. Replace control if problem persists. |
| EF | Operating parameter reading error | See EE | |

Initial Start-Up

After all the checks outlined in the installation section of this manual have been made, the case is ready to be put into service. Turn on the Power at the breaker box and flip the Power Switch and Light Switch on unit to the on position. At start up from a warm unit, it is recommended that the temperature control is set at a warm setting, such as After the unit has gone through several cycles, change the control to a mid-range setting, then to a colder setting if necessary to maintain desired product temperature



NOTICE: This refrigerated display case is designed to operate in a maximum environment of 75 DEG. F and 55% relative humidity. Exceeding these limits will cause poor case performance, excessive sweating & overflow condensate pan.

Placing Product into Case

- Do not exceed 75 pounds of weight per shelf. Heavy product should be distributed evenly across the entire shelving area.
- Determine desired shelving location before placing product in case. Product must be removed to readjust shelf location.
- Allow a minimum of 2" between top of product and bottom of shelf.
- Do not overhang the front or rear of shelves with product. Improper clearance in front and rear of shelf will block the refrigerated airflow and will cause product loss.
- Do not block the slots along the front and rear air discharge slots. Covering these slots will block the refrigerated airflow and could cause product loss.
- The display deck is removable for cleaning and can become dislodged in shipment. To ensure proper airflow and performance of the case, make sure that the display deck is pushed completely down.
- Allow refrigerated models to run for at least two hours before placing pre-chilled product into unit.



NOTICE: CASE MUST BE STOCKED WITH PRE-CHILLED PRODUCT ONLY.

CLEANING INSTRUCTIONS

Acrylic Air Deflector Cleaning



NOTICE: Clear acrylic air deflector requires special washing procedures to prevent hazing and yellowing of material.

NEVER USE paper towels (wet or dry) for cleaning or drying and never use a dry towel.

NEVER USE glass cleaner of any kind.

Lightly dust (not wipe) surface with a damp Micro Fiber towel or chamois. The surface can then be washed using a small amount of dishwashing detergent such as Dawn or Joy and lukewarm water. Use a Micro Fiber towel or chamois, applying only light pressure. The cloth or chamois must be kept free of grit by frequently rinsing. Rinse surface with clear water and dry by blotting with a damp Micro Fiber towel or chamois.

Daily Cleaning

The case should be cleaned thoroughly, as described in the weekly cleaning section, before it is used for the first time.



NOTICE: Avoid splashing or soaking any electrical components with water to prevent electrical damage to the case.



NOTICE: Shut off lights and power switches and remove all products from case. Allow sufficient time for the unit to reach room temperature before proceeding with cleaning.



NOTICE: Remove all products from the case before proceeding with cleaning procedure.



NOTICE: Acrylic air deflector requires special washing procedures to prevent hazing and yellowing of material. Clean as described in “Acrylic Air Deflector Cleaning” section of this manual.

Note: For major spills or foreign material buildup use complete weekly cleaning instructions.

Note: Detergents are not recommended and do not use abrasive cleaners or pads to prevent scratching of surfaces.

1. Dip rag in warm soapy water and ring out thoroughly. Wipe complete interior of case and dry with soft dry towel.
2. The remaining exterior surface should be wiped down using any ammoniated cleaners or soapy warm water and dried with soft dry towel.
3. **IMPORTANT: Cleaning the clear acrylic plastic front air deflector. Clean as described in “Acrylic Air Deflector Cleaning” section of this manual.**

Weekly Cleaning



NOTICE: Avoid splashing or soaking any electrical components with water to prevent electrical damage to the case.



NOTICE: Shut off lights and power switches and remove all products from case. Allow sufficient time for the unit to reach room temperature before proceeding with cleaning.



NOTICE: Remove all products from case before proceeding with cleaning procedure.



NOTICE: Acrylic front air deflector requires special washing procedures to prevent hazing and yellowing of material.

Note: Detergents are not recommended and do not use abrasive cleaners or pads to prevent scratching of surfaces.

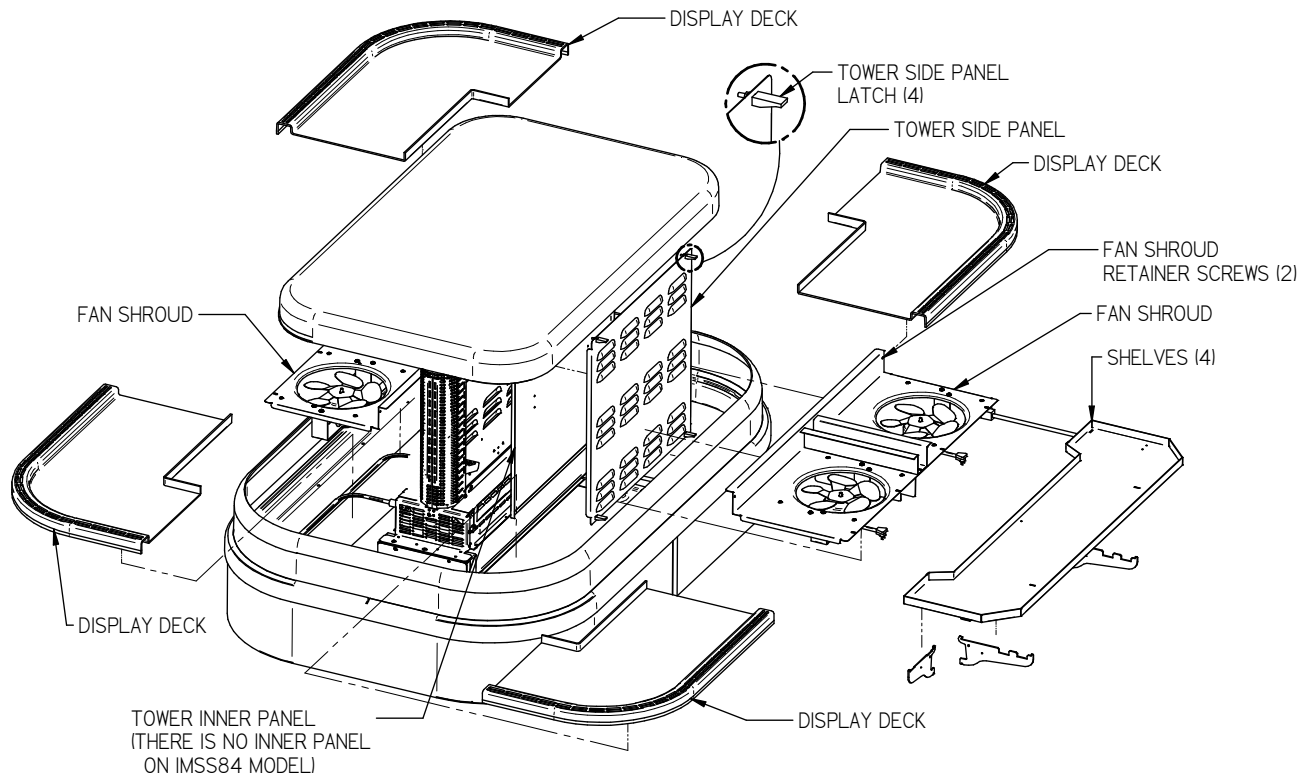

ILLUSTRATION IS TYPICAL,
SOME MODELS MAY HAVE MORE PANELS, SHELVES AND DISPLAY DECKS

1. Remove interior shelving from unit as described in the “Shelving Installation and Removal” section of this manual.
2. Dip rag in warm soapy water and ring out thoroughly. Clean all shelves and shelf brackets and dry with soft dry towel.
3. Remove tower side panels by lifting (4) latch levers and pulling tower side panel out away from tower.
4. Remove the tower inner panel by lifting panel up until retaining pins clear key slots hole. Pull panel out of tower.
5. Dip rag in warm soapy water and ring out thoroughly. Clean the tower side panels, tower inner panels and inside both tower ends. Dry with soft dry towel
6. Lift the display decks up and out of evaporator tub.
7. Remove the fan shroud assembly by removing (4) retaining screws from the outer flange and the (2) from the inner flange. Lift the fan shroud assembly and reach in and unplug the evaporator fan motor cord(s). Lift fan shroud assembly out of tub.
8. Clean the display deck(s) using warm soapy water and a brush. Rinse thoroughly and allow dry. Wipe off fan shroud assembly (do not rinse or submerge fan motors).
9. Clean the entire interior of the case using warm soapy water. Wipe off all soapy water with a damp cloth and allow to dry. (DO NOT use solvents such as Acetone, Benzene, Carbon Tetrachloride, and Lacquer Thinners)

10. IMPORTANT: Cleaning the clear acrylic plastic front air deflector. Clean as described in “Acrylic Air Deflector Cleaning” section of this manual.

11. Reassemble all components in reverse order.

NOTE: Depending on the amount of usage and spillage of foreign material, some fasteners may have to be removed and parts disassembled to allow proper cleaning of the unit.

Maintenance

Cleaning Condenser Coil



NOTICE:

Condenser coil or optional air filter must be cleaned a minimum of twice per month to insure proper refrigeration performance and prevent compressor failure. In some environments it may be necessary to clean more frequently. FAILURE TO CLEAN CONDENSER COIL WILL VOID COMPRESSOR WARRANTY.

It is very important that the Condenser coil or optional air filter is cleaned twice per month to insure proper refrigeration performance and to prevent compressor failure. In some environments, it may be necessary to clean more frequently. Failure to clean condenser coil will void condenser warranty. This procedure is for Self-Contained models. The remote condenser coil must also be cleaned at same intervals.

1. Disconnect power to the unit.
2. On IMSS60 and IMSS84 Remove the side panel with the narrow set of louvers and on IMSS120 remove panels from both sides at the end the control panel is located. See the illustration in the "Bottom Panel Removal" section of this manual for panel clarification.

Carefully vacuum the front surface of condenser coil. Take care not to bend coil fins with vacuum cleaner nozzle.

-If equipped with optional air filter remove filter and carefully vacuum the front surface of condenser coil. Take care not to bend coil fins with vacuum cleaner nozzle. Wash filter using warm soapy water, rinse, and let dry. Apply a generous coat of filter coat adhesive to both sides of filter. (Filter coat adhesive is available through any restaurant supply distributor.) Recommended Super Filter Coat

NOTE: Failure to coat filter with a fresh coat of filter adhesive after cleaning will prevent filter from working properly. Failure to do so will allow the condenser coil to plug, which will affect refrigeration performance and could cause compressor failure.

3. Reinstall side panel(s).

VACUUM FRONT
SURFACE OF
CONDENSER COIL



SERVICE INFORMATION

CAUTION
RISK OF ELECTRIC SHOCK

DISCONNECT POWER BEFORE
SERVICING UNIT

**Before any service work
is performed on the
case, make sure all
power is disconnected
to the case.**

To find a service company in your area, please visit our website at www.federalindustries.com. There you can also find self-service tools to help you get the answers you need faster!

For Warranty Service Requests & ALL Technical Support please contact:

- Phone: (800) 356-4206 and choose the Tech Support/Warranty Option
- Email: Service@federalind.com

For Warranty Compressors please contact the Parts Department:

- Phone: (800) 356-4206 and choose the Warranty Parts Option
- Email: Parts@Federalind.com



Federal Industries has partnered with Parts Town for ALL Non-Warranty Part Identification, Pricing, Lead Times, Orders & Freight Quotes. Please contact Parts Town directly if you need parts:

- Website: PartsTown.com
- Email: CustomerService@PartsTown.com
- Phone: 833-809-8188



Pre-Service Checklist

You may avoid the cost and inconvenience of an unnecessary service call by first reviewing this checklist of frequently encountered situations that can cause unsatisfactory case performance.



CAUTION: Before servicing case, turn off power at the main breaker of fuse box.

Case Does Not Operate

- Check for disconnected power supply.
- Check for tripped breaker on blown fuse.
- Check that the thermostat display is on and that the green indicator light is lit.

Lights Do Not Operate

- Check that light switch is on.
- Check for tripped breaker or blown fuse.
- Check that light housing cords are plugged in correctly to sockets in the tower

Case Temperature Too Warm

- Check that the cold air inlet and outlet slots are not blocked.
- Check for a blocked or dirty condenser coil.
- Check for cold airflow. Lack of adequate cold airflow could indicate a defective evaporator fan or a blocked evaporator coil. Check that paper or foreign materials are not blocking evaporator. If the evaporator coil is blocked due to excessive frost, put into manual defrost. Excessive frost can buildup overtime if the case is set too cold or if there is excessive humidity in the store.
- Check all the fans in the evaporator compartment and tower are running.

Case Sweating Note: Some interior sweating is normal on this case.

- Check room ambient – Case is designed to operate in an environment not to exceed 75°F and 55% relative humidity.
- Check all the fans in the evaporator compartment and tower are running.

Overflow of Condensate Pan

- Check that drain in bottom of tub floor is not plugged.
- Check that drain trap to the condensate pan is not plugged

Overflow of Optional Condensate Pump:

- Check that drain in bottom of tub floor is not plugged.
- Check that drain trap to the condensate pan is not plugged
- Check that drain lines from pump is not plugged or pinched.
- Check to see that pump float is operating correctly.
- Verify that pump is plugged in and has power.
- Replace pump if still not pumping condensate.

Special Service Situations

There are rare occasions when the refrigerant charge must be evacuated from a case to perform service work. In those situations, Federal Industries recommends that the refrigerant charge be evacuated into a recovery system to prevent the possibility of hydrofluoro olefin (HFO) from being released into the atmosphere.

The release of HFO into the atmosphere is a potential source of global warming. Note the condensing unit that was supplied with this case has a receiver tank large enough to hold all the charge you may be able to pump down the system when service is required.

If moisture or liquid is observed around or under a Federal Industries case, an immediate investigation should be made by qualified personnel to determine the source of the moisture or liquid. The investigation made should determine if the case is malfunctioning or if there is a simple housekeeping problem.

Moisture or liquid around or under a case is a potential slip / fall hazard for persons walking by or working in the general area of the case. Any case malfunction or housekeeping problem that creates a slip / fall hazard around or under a case should be corrected immediately.

SALE & DISPOSAL

If you the owner sells or gives away this Federal Industries case it is the owner's responsibility to make sure that all safety labels and the Installation-Service Manual are included with it. If you need replacement labels or manuals, Federal Industries will provide them free of charge. Contact the customer service department at Federal Industries at (800) 356-4206.

The customer service department at Federal Industries should be contacted at the time of sale or disposal of your case so records may be kept of its new location.

If you sell or give away your Federal Industries case, you should evacuate the refrigerant charge before shipment. Federal Industries recommends that the charge be evacuated into a recovery system to prevent the possibility of HFO's from being released into the atmosphere.

ELECTRICAL DATA

| <u>Model</u> | <u>IMSS60SC/IMSS84SC</u> | | <u>IMSS60R/IMSS84R</u> | |
|-----------------------------------|--------------------------|---------------------|-------------------------|---------------------|
| <u>Power Supply, Volts</u> | <u>230 Volts</u> | | <u>230 Volts</u> | |
| Frequency | 60 Hertz | | 60 Hertz | |
| Phase | 1 Phase | | 1 Phase | |
| Number of Wires | 2 + GND | | 2 + GND | |
| | <u>AMPS</u> | <u>VOLTS</u> | <u>AMPS</u> | <u>VOLTS</u> |
| Compressor | 12.6/12.0 | 230 | - | - |
| Condenser Fan | .8 | 230 | - | - |
| Base Fan | - | - | .15 | 230 |
| Evaporator Fan Motor (QTY 2 or 4) | 0.15 ea. | 230 | 0.15 ea. | 230 |
| Lights Power Supply 24V | .8 | 230 | .8 | 230 |
| Condensate Pan Heater | 7.8 | 230 | - | - |
| Condensate Pump | - | - | .75 | 230 |

Refer to the rating plate data attached to side of base for Maximum Fuse Size and Minimum Circuit Ampacity.

| <u>Model</u> | <u>IMSS120SC</u> | | <u>IMSS120R</u> | |
|-----------------------------------|-------------------------|---------------------|-------------------------|---------------------|
| <u>Power Supply, Volts</u> | <u>230 Volts</u> | | <u>230 Volts</u> | |
| Frequency | 60 Hertz | | 60 Hertz | |
| Phase | 1 Phase | | 1 Phase | |
| Number of Wires | 2 + GND | | 2 + GND | |
| | <u>AMPS</u> | <u>VOLTS</u> | <u>AMPS</u> | <u>VOLTS</u> |
| Compressor | 12 | 230 | - | - |
| Condenser Fan (QTY 2) | .5 ea | 230 | - | - |
| Evaporator Fan Motor (QTY 6) | 0.15 ea. | 230 | 0.15 ea. | 230 |
| Lights Power Supply 24V (QTY 2) | 1.6 | 230 | 1.6 | 230 |
| Condensate Pan Heater | 9.0 | 230 | - | - |
| Condensate Pump | - | - | .75 | 230 |

Refer to the rating plate data attached to side of base for Maximum Fuse Size and Minimum Circuit Ampacity.

CONTROL OPERATION

Electronic Control

This unit is equipped with CAREL temperature control. The control parameters are set at the factory and cannot be manually changed in the field. Control parameter changes can only be made by downloading a new set of parameters via a program chip supplied by Federal Industries. The preset control parameters are listed on the chart in the Settings Chart below.

Operation

The control uses two sensors, one located in the air stream and one located on the evaporator coil. The sensor located in the air stream is referred to as the temperature control sensor. The sensor located on the evaporator coil is referred to as the coil sensor.

The temperature control sensor is located inside the center tower at the top. The sensor location is critical for proper operation on the unit. Do not move or relocate this sensor.

The coil sensor is strapped to the evaporator coil. This sensor location is critical for proper operation of the unit. Do not move or relocate this sensor.

The temperature control is set to cut in at 39 degrees F. The Temp control cuts out at 14 degrees F at the coldest setting "9" and 28 degrees F at the warmest setting, '1' on the control display.

The temp control turns off the refrigeration system when you "press and hold" the top arrow / power button for approx. 3 seconds until "OFF" flashes on display.

Defrost Cycle

The CAREL control is programmed to initiate defrost via two different methods. There are 3 programmed defrost cycles in the case which will initiate a defrost cycle every 8 hours. The unit does not have a time clock so the defrost cycles cannot be set for any specific time of day.

The unit also has an 'On demand' defrost feature that will initiate a defrost when the temperature differential between the evaporator temperature and the air temperature is more than 15 degrees for 5 minutes after 30 minutes into the refrigeration cycle.

Maximum Run Timer, Before 5/23/12 Only

The unit is equipped with a maximum run timer that is preset at the factory for 60 minutes on and 10 minutes off. If the temperature control does not reach cut out set point after running for one hour, the timer will turn the compressor off for 10 minutes.

Maximum Run Timer, After 5/1/18

The unit is equipped with a maximum run timer that is preset at the factory for 75 minutes on. If the temperature control does not reach cut out set point after running for one hour, the timer will turn the compressor off for a minimum of 2 minutes.

CONTROL PARAMETERS IMSS60 & 84 SELF-CONTAINED

Table 1 - Control Parameters

| Parameter Description | | | | | | | | | |
|---|--------|------|------|------|------|------|------|------|------|
| Control Setpoint → | 1 | 2 | 3 | 4 | 5 | 6 | 7 | 8 | 9 |
| Compressor Cut out [°F] | 28.0 | 26.2 | 24.5 | 22.7 | 21.0 | 19.2 | 17.5 | 15.7 | 14.0 |
| Compressor Cut in [°F] | 39.0° | | | | | | | | |
| Compressor Min On Time | 5 min | | | | | | | | |
| Compressor Min Off Time | 2 min | | | | | | | | |
| Compressor Max Run Time | 75 min | | | | | | | | |
| Defrost Termination Temp [°F] | 43.0 | | | | | | | | |
| Time to first defrost | 8 hr. | | | | | | | | |
| Time to subsequent defrost | 8 hr. | | | | | | | | |
| Maximum Defrost duration | 30 min | | | | | | | | |
| Defrost on demand differential [°F] | 15.0 | | | | | | | | |
| Delay for defrost on demand | 5 min | | | | | | | | |
| Time delay to the next defrost on demand | 30 min | | | | | | | | |

Table 2 - Temperature Probe Common Resistance Chart

| Probe Temp | Maximum Resistance [Ω] | Normal Resistance [Ω] | Minimum Resistance [Ω] |
|---------------|------------------------|-----------------------|------------------------|
| 32°F (0°C) | 27.83 | 27.28 | 26.74 |
| 77°F (25°C) | 10.1 | 10 | 9.9 |
| 212°F (100°C) | 1 | 0.97 | 0.94 |

CONTROL PARAMETERS IMSS120 SELF-CONTAINED

Table 3 - Control Parameters

| Parameter Description | | | | | | | | | |
|---|--------|------|------|------|------|------|------|------|------|
| Control Setpoint → | 1 | 2 | 3 | 4 | 5 | 6 | 7 | 8 | 9 |
| Compressor Cut out [°F] | 32.0 | 30.5 | 29.0 | 27.5 | 26.0 | 24.5 | 23.0 | 21.5 | 20.0 |
| Compressor Cut in [°F] | 39.0° | | | | | | | | |
| Compressor Min On Time | 5 min | | | | | | | | |
| Compressor Min Off Time | 2 min | | | | | | | | |
| Compressor Max Run Time | 75 min | | | | | | | | |
| Defrost Termination Temp [°F] | 43.0 | | | | | | | | |
| Time to first defrost | 8 hr. | | | | | | | | |
| Time to subsequent defrost | 8 hr. | | | | | | | | |
| Maximum Defrost duration | 30 min | | | | | | | | |
| Defrost on demand differential [°F] | 15.0 | | | | | | | | |
| Delay for defrost on demand | 5 min | | | | | | | | |
| Time delay to the next defrost on demand | 30 min | | | | | | | | |

Table 4 - Temperature Probe Common Resistance Chart

| Probe Temp | Maximum Resistance [Ω] | Normal Resistance [Ω] | Minimum Resistance [Ω] |
|---------------|------------------------|-----------------------|------------------------|
| 32°F (0°C) | 27.83 | 27.28 | 26.74 |
| 77°F (25°C) | 10.1 | 10 | 9.9 |
| 212°F (100°C) | 1 | 0.97 | 0.94 |

CONTROL PARAMETERS ALL 1MSS REMOTES

Table 5 - Control Parameters

| Parameter Description | | | | | | | | | |
|---|--------|------|------|------|------|------|------|------|------|
| Control Setpoint → | 1 | 2 | 3 | 4 | 5 | 6 | 7 | 8 | 9 |
| Compressor Cut out [°F] | 30.0 | 28.0 | 26.0 | 24.0 | 22.0 | 20.0 | 18.0 | 16.0 | 14.0 |
| Compressor Cut in [°F] | 38.0° | | | | | | | | |
| Compressor Min On Time | 5 min | | | | | | | | |
| Compressor Min Off Time | 2 min | | | | | | | | |
| Compressor Max Run Time | 60 min | | | | | | | | |
| Defrost Termination Temp [°F] | 43.0 | | | | | | | | |
| Time to first defrost | 6 hr. | | | | | | | | |
| Time to subsequent defrost | 6 hr. | | | | | | | | |
| Maximum Defrost duration | 30 min | | | | | | | | |
| Defrost on demand differential [°F] | 18.0 | | | | | | | | |
| Delay for defrost on demand | 5 min | | | | | | | | |
| Time delay to the next defrost on demand | 30 min | | | | | | | | |

Table 6 - Temperature Probe Common Resistance Chart

| Probe Temp | Maximum Resistance [Ω] | Normal Resistance [Ω] | Minimum Resistance [Ω] |
|---------------|------------------------|-----------------------|------------------------|
| 32°F (0°C) | 27.83 | 27.28 | 26.74 |
| 77°F (25°C) | 10.1 | 10 | 9.9 |
| 212°F (100°C) | 1 | 0.97 | 0.94 |

REFRIGERATION OPERATION

Self-Contained Models

| | |
|-----------------------------------|-------------------|
| Refrigeration R449 Charge IMSS60 | 6.0 Pounds |
| Refrigeration R449 Charge IMSS84 | 7.5 Pounds |
| Refrigeration R449 Charge IMSS120 | 9.5 Pounds |

The self-contained models are shipped from the factory with a completely operational R449A refrigeration system and require no modifications or adjustments upon installation. Case must be installed as per the installation section of this manual to provide proper condensing air cooling.

Self-Contained Refrigeration Operation

The unit temperature is controlled by the Electronic control and timers outlined in the control section of this manual.

Note: The condenser fan runs continuously.

Remote Models

BTU Requirements

| | |
|----------|--------------------------------------|
| IMSS60R | 12,800 BTU'S @20F EVAP / 90F Ambient |
| IMSS84R | 16,400 BTU'S @20F EVAP / 90F Ambient |
| IMSS120R | 25,200 BTU'S @20F EVAP / 90F Ambient |

Pressure Control Settings

- Use pressure gauges to set pressure control.

| | |
|-----------------------------------|-------------------------|
| Refrigeration R449A Charge | CHARGED IN FIELD |
| Remote Low Press. Switch Cut In | 50 psi |
| Remote Low Press. Switch Cut Out | 15 psi |
| Adjustable Head Master | 200 psi |
| Remote High Press. Switch Cut Out | 400 psi |

The remote models are designed to use R449A refrigerant and shipped from the factory with the evaporator coil, expansion valve, sight glass and refrigerant solenoid valve. Drier filter must be installed in field for proper operation. Electronic control runs identical to the Self-Contained models except the electronic control opens and closes a refrigeration solenoid valve located on the suction line instead of turning on and off a compressor. The solenoid valve closes and shuts off the refrigeration flow to the unit and initiates a pump down cycle. This will allow the remote low-pressure switch to open and shut off remote compressor.

The condensing unit and pressure controls are optionally supplied from the factory for remote location installation. The condensing unit must be mounted and wired by the installer. The high low-pressure switch must be wired in series with the compressor power supply as shown in diagram on the next page.

Remote Condensing Unit Installation

1. Mount condensing unit as close as possible to the remote display case as practical. Follow condensing unit manufacturer guidelines for proper piping and distance requirements.
2. All refrigeration and/or electrical materials between the condensing unit and display case are to be supplied by installing contractor.
3. Route properly sized and designed refrigeration lines from the condensing unit to the cabinet.

Horizontal suction lines should be pitched downward towards the condensing unit at least $\frac{1}{2}$ " per 10' run to aid the oil drainage. A "P" trap must be installed in the suction line at the foot of every riser to insure oil return. Dry nitrogen must be used to flow through tubing while brazing refrigeration lines.

4. Suction line must be insulated the entire length with Armaflex (or equivalent). Do not run liquid line inside insulation with suction line.
5. The remote high/low-pressure control must be mounted, wired and set pressures by the installer.
6. Leak check condensing unit, cabinet, and all connecting tubing. Cabinet and condensing unit tubing should be checked to insure no leaks occurred during shipping or from rough handling.

Make certain all refrigeration valves are opened and evacuate system to 500 microns. Charge the system with refrigerant type specified on the data plates.

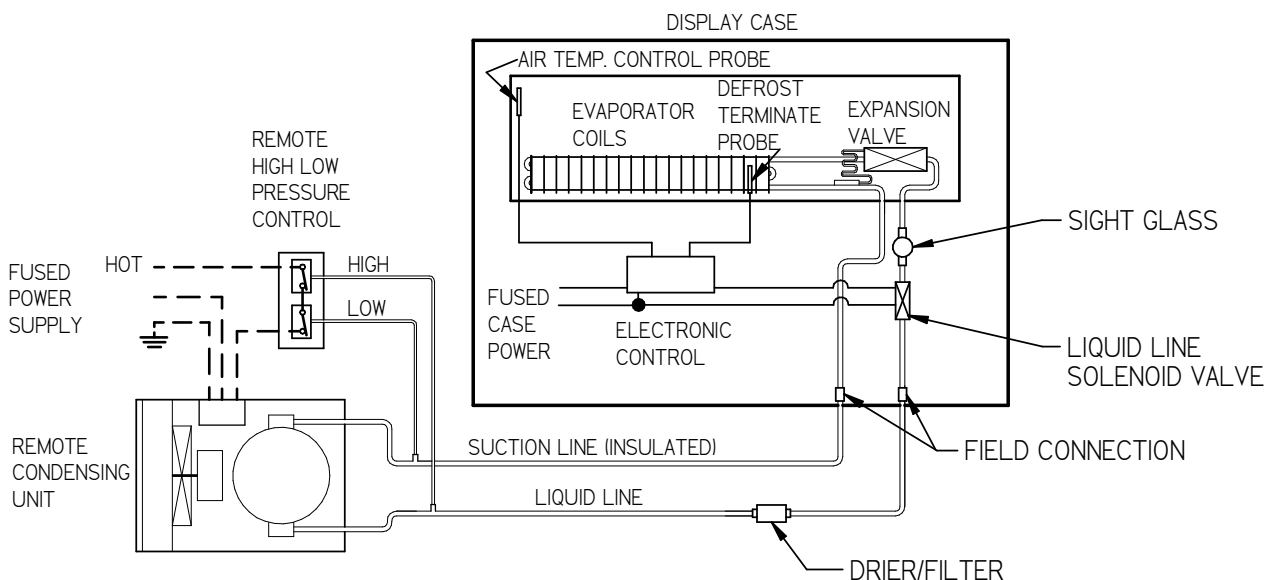

Electronic Expansion Valve (EEV) After 12/1/19

A traditional TXV uses springs and a temperature bulb to open and close a valve port that controls the flow of refrigerant entering the evaporator coil. An electronic expansion valve (EEV) controls the refrigerant flow much more precisely, increasing the performance and efficiency of the refrigeration system. The EEV controls the flow of Refrigerant by opening and closing the valve port based on the response to signals sent to the EEV by an electronic controller. The electronic Control bases these signals by processing information provided from a temperature sensor and pressure transducer located on the discharge side of the evaporator coil. These sensors monitor the evaporator superheat and protects the compressor from any liquid flood back under low superheat conditions.

EEV Controller Settings

The electronic expansion valve controller also allows the use of different types of refrigerants without the need to change the expansion valve.

The controller is set from the factory to run on 449A refrigerant and will not need any changes to the control unless another refrigerant is used.

Note: Check your State and Local regulations for approved refrigerants for your install location. Federal Industries is not liable for any alternate refrigerants used.

The control is located on the side of the case opposite the condo pump.

Note: Never change any of the other setting other than the refrigerant type. It may also be necessary to change the superheat setting only when using a different refrigerant.



| Indicator lights | |
|------------------|---|
| Red light | - critical alarm (system is NOT running) |
| Yellow light | - non-critical alarm (system running) |
| Green light | - compressor on |
| Green blinking | - compressor waiting on timer to start/stop |

Changing Refrigerant

- Access the set point mode by pressing and holding the **ENTER** button until Ctl displays on the screen.
- Use the **▲** up or **▼** down arrows to advance through the available set points until rFG displays on the screen and press the **ENTER** button.
- Use the **▲** up or **▼** down arrows until the desired refrigeration displays on the screen and press and hold the **ENTER** button until rFG once again displays on the screen.
- Press the **BACK** to return to escape the settings menu.

Changing Superheat

- Access the set point mode by pressing and holding the **ENTER** button until Ctl displays on the screen.
- Use the **▲** up or **▼** down arrows to advance through the available set points until SSP displays on the screen and press the **ENTER** button.
- Use the **▲** up or **▼** down arrows to set the desired superheat displays on the screen and press and hold the **ENTER** button until SSP once again displays on the screen.
- Press the **BACK** to return to escape the settings menu.

PARTS LIST

| Refrigeration System | IMSS60 | IMSS84 | IMSS120 |
|---|-----------------------|------------------------|------------------------|
| Condensing Unit (Self Contained) Before 8/1/14 | 30-19025 | 30-19025 | 30-19675 |
| Replacement Compressor | 30-19719 | 30-19719 | 30-20041 |
| Condensing Unit (Self Contained) After 8/1/14 | 30-20448 | 30-20183 | 30-20284 |
| Replacement Compressor | 30-20290 | 20-20291 | 30-20848 |
| Evaporator Coil Left/ Right (Before 12/1/19) | 33-18811-L/33-18811-R | 33-19287-L/33-19287-R | 33-19647-L/33-19647-R |
| Evaporator Coil Left/ Right (After 12/1/19) | 33-19518-L/33-19518-R | 33-19287-L/33-19287-1R | 33-19647-L/33-19647-1R |
| Expansion Valve TXV (Before 12/1/19) | 32-19408 | 32-19408 | 32-19750 |
| Expansion Valve TXV (After 12/1/19) | 32-20874 | 32-21063 | 32-21063 |
| Remote EEV (After 12/1/19) | 32-21226 | 32-21226 | 32-21227 |
| Sight Glass | 32-54011 | 32-54011 | 32-54011 |
| Refrigerant Filter/Drier | 32-19067 | 32-19067 | 32-19067 |
| Refrigeration Solenoid Valve (Remote) | 32-19153 | 32-19153 | 32-19153 |
| Motor Evaporator Fan | 41-19070 | 41-19070 | 41-19070 |
| Wire Harness Evaporator Motor | 43-19083 | 43-19083 | 43-19735 |
| Blade Evaporator Fan | 72-12254 | 72-11450 | 72-12254 |
| Electrical Components | | | |
| LED Light Bar Top BEFORE 8/1/18 | 42-19038 | 42-19038-3 | 42-19038-6 |
| LED Light Bar Shelf BEFORE 8/1/18 | 42-19038-7 | 42-19038-3 | 42-19038 |
| Shelf Lamp Cord BEFORE 8/1/18 | 43-19061 | 43-19061 | 43-19061 |
| Shelf Lamp Socket | 43-19060 | 43-19080-B | 43-19080-B |
| Light power Supply 12V BEFORE 8/1/18 | 39-19039 | 39-19039 | 39-19039 |
| LED Light Bar Top AFTER 8/1/18 | 42-20871-42C35 | 42-20871-66C35 | 42-20871-54C35 |
| LED Light Bar Shelf AFTER 8/1/18 | 42-20871-38C35 | 42-20871-60C35 | 42-20871-48C35 |
| Top Lamp Cord AFTER 8/1/18 | 43-20867-1B | 43-20867-1B | 43-20867-1B |
| Shelf Lamp Cord AFTER 8/1/18 | 43-20861-1B | 43-20861-1B | 43-20861-1B |
| Light power Supply 24V AFTER 8/1/18 | 39-20555 | 39-20555 | 39-20555 |
| Power Switch | 41-13733 | 41-13733 | 41-19760 |
| Light Switch | 41-11066 | 41-11066 | 41-11066 |
| Temp Control (Before 5/23/12) | 32-19027 | 32-19027 | 32-19027 |
| Temp Control Display (Before 5/23/12) | 32-19092 | 32-19092 | 32-19092 |
| Temp Control Self Contained(Between 5/23/12-5/1/18) | 32-19445-3 | 32-19445-7 | 32-19445-7 |
| Temp Control Self Contained(After 5/1/18) | 32-19865-3 | 32-19865-3 | 32-19865-7 |
| Temp Control Remote (Between 5/23/12-5/1/18) | 32-19445-3 | 32-19445-71 | 32-19445-71 |
| Temp Control Remote (After 5/1/18) | 32-19865-71 | 32-19865-71 | 32-19865-71 |
| Temp Control Display (Between 5/23/12 - 5/1/18) | 32-19446 | 32-19446 | 32-19446 |
| Ribbon Cable display (Before 5/1/18) | 32-19093 | 32-19093 | 32-19093 |
| Probe Temp | 32-19094 | 32-19094 | 32-19209 |
| Timer, Max Run (Before 5/23/12) | 41-17324 | 41-17324 | - |
| Condensate Pan Ass'y (After 9/13) | SA5945 or 40-19996 | SA5945 or 40-19996 | SA5946 or 40-19997 |
| Heater Condensate Pan ((After 9/13) | 40-19996-1 | 40-19996-1 | 40-19997-1 |
| Condensate Pan Ass'y (Before 9/13) | SA4889 | SA4889 | SA5345 |
| Heater Condensate Pan (Before 9/13) | 40-17861 | 40-17861 | 40-19392 |
| Condensate evap pan (Before 9/13) | 47-15679 | 47-15679 | M19107 |
| HighTemp Safety Ass'y (Before 9/13) | SA-1880 | SA-1880 | - |
| Float Switch condensate Pan (Before 9/13) | 41-13022 | 41-13022 | - |
| Float Condensate Pan (Before 9/13) | SA2928-1 | SA2928-1 | - |
| Optional Power Cord | 43-19090 | 43-19090 | - |
| Optional Condensate Pump | 47-15687 | 47-15687 | 47-15687 |

PARTS LIST CONTINUED

| | | | |
|---|------------------------|------------------------|------------------------|
| EEV Control | 32-21223 | 32-21223 | 32-21223 |
| EEV Temp Control Probe | 32-21224 | 32-21224 | 32-21224 |
| EEV Pressure Transducer | 32-21225 | 32-21225 | 32-21225 |
| Miscellaneous Components | IMSS60 | IMSS84 | IMSS120 |
| Display Deck Plastic Left/Right | 15-18856-L/ 15-18856-R | 15-19292-L/ 15-19292-R | 15-19292-L/ 15-19292-R |
| Display Deck Plastic Center | - | - | 15-19720 |
| Fastener Pad Set Display Deck | 77-17848/77-17849 | 77-17848/77-17849 | 77-17848/77-17849 |
| Metal Shelf Assy w/light BEFORE 8/1/18 | SA5397-2 | SA5397-1 | SA5399-1L/SA5399-1R |
| Metal Shelf NO LIGHT AFTER 8/1/18 | M20958-2 | M20958-1 | M20957-1L/M20957-1R |
| Air Diffuser Air Discharge | W11533-1 | W11533-5 | W11533-7 |
| Shelf Bracket Long | 67-18727 | 67-18727 | 67-18727 |
| Shelf Bracket Short | 67-18727-1 | 67-18727-1 | 67-18727-1 |
| Thermometer | 32-13662 | 32-13662 | 32-13662 |
| Straight Deflector End | 15-19729-1 | 15-19729-1 | 15-19729-1 |
| Straight Deflector Side | 15-19730-4 | 15-19730-2 | 15-19730-1 |
| Acrylic Air Deflector Seal | 64-19773 | 64-19773-1 | 64-19773-2 |
| Acrylic Deck Product Stop | 15-19863-1 | 15-19863-3 | 15-19863-3/15-19863-5 |
| Replacement Optional Condenser Air Filter | 16-19228 | 16-19228 | 16-19228-1 |
| Super Filter Coat | 22-21164 | 22-21164 | 22-21164 |

Case Wiring Diagrams

Self-Contained IMSS60SC BEFORE 5/23/12

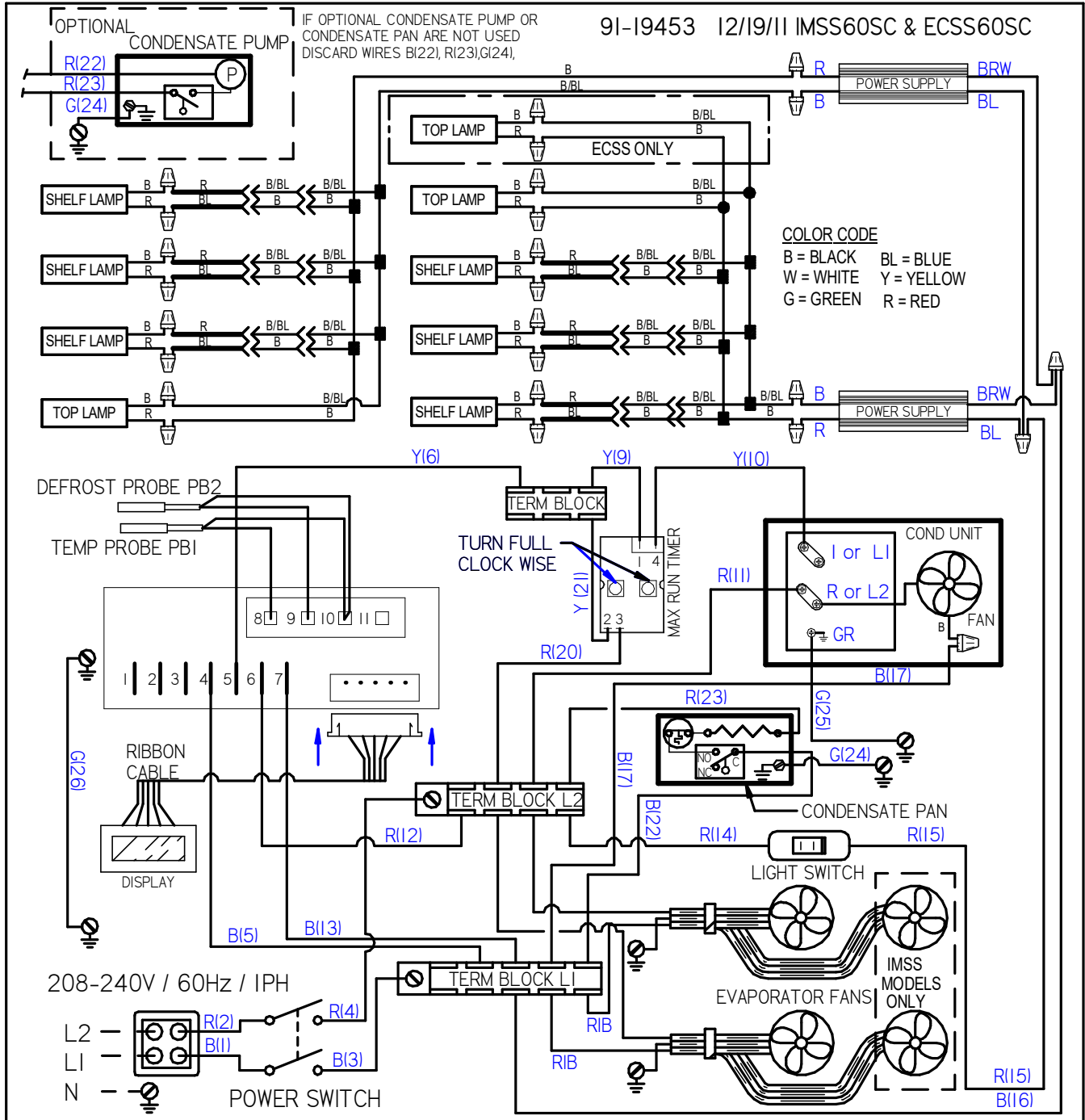

Self-Contained IMSS60SC BETWEEN 5/23/12 & 8/1/14

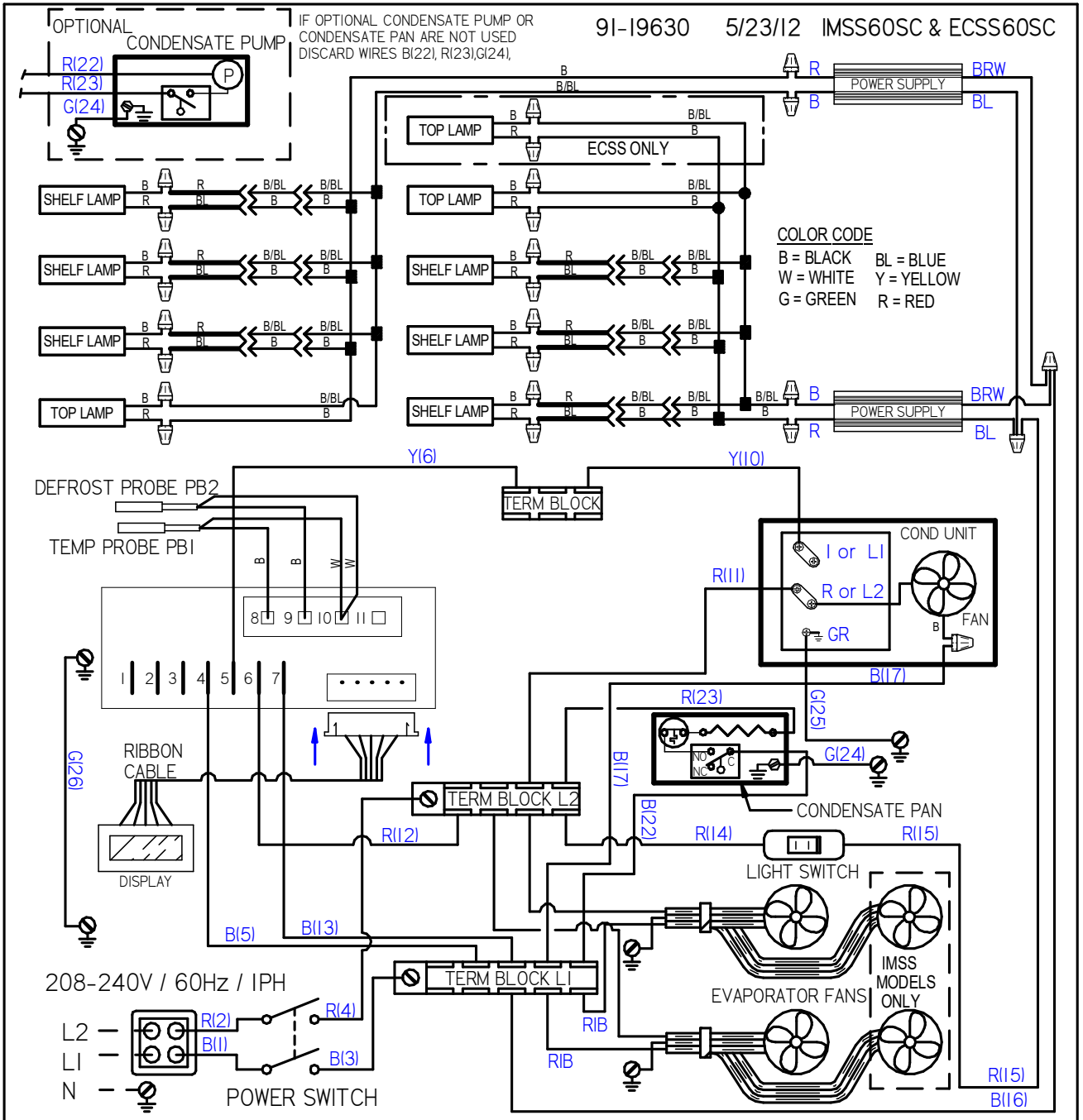

Self-Contained IMSS60SC AFTER 12/1/19

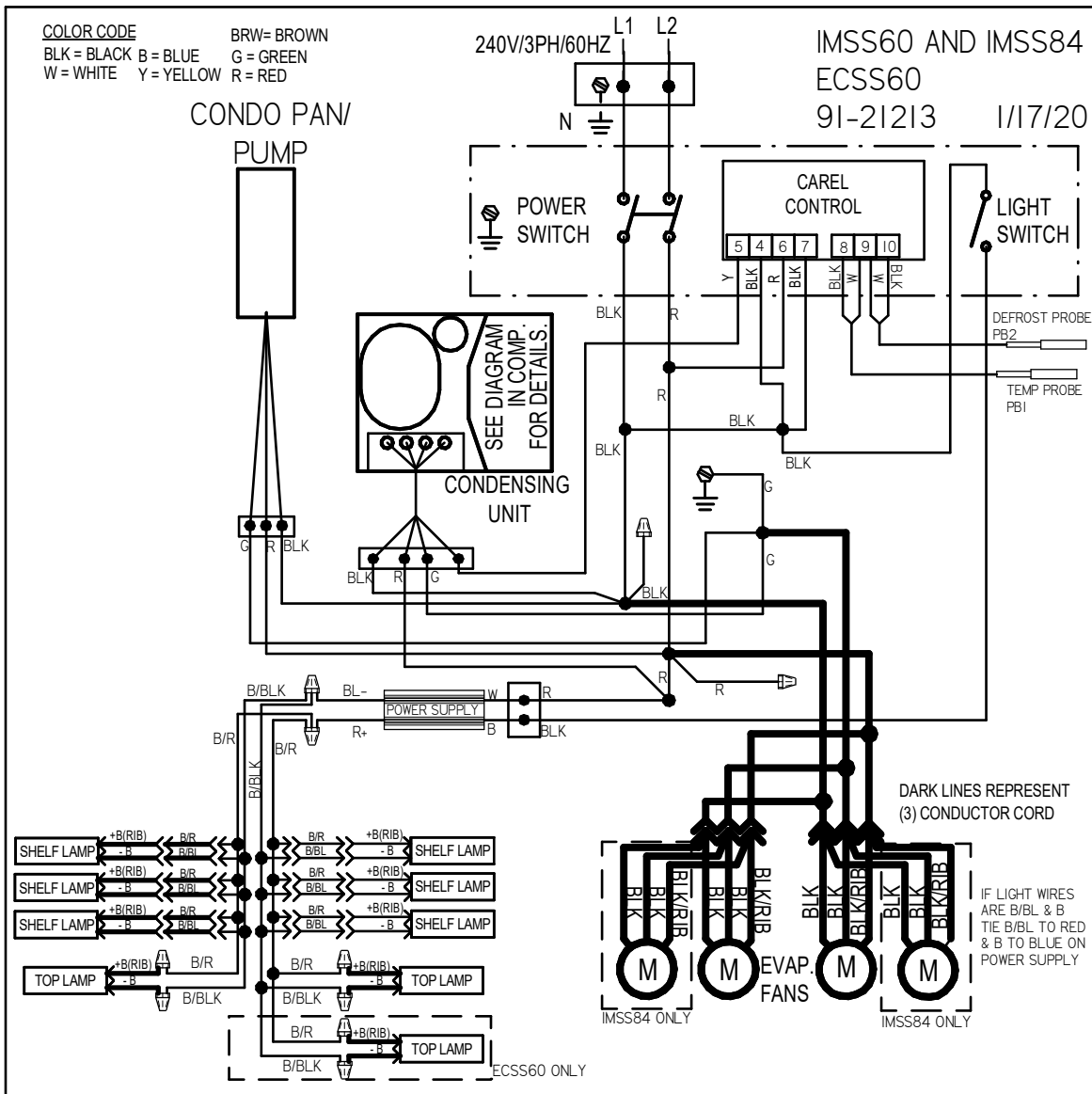

Self-Contained IMSS84SC BEFORE 5/23/12

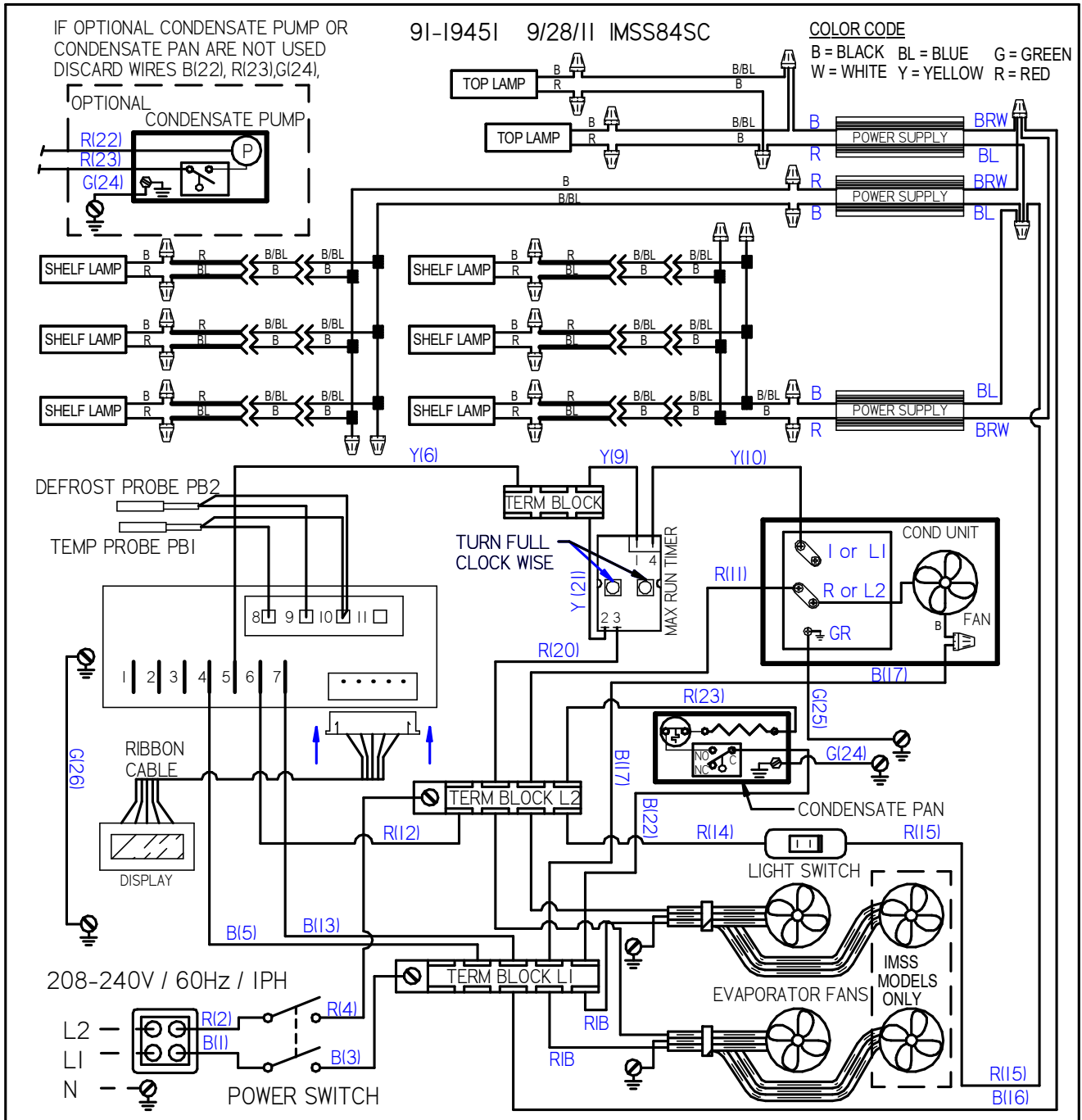

Self-Contained IMSS84SC BETWEEN 5/23/12 & 8/1/14

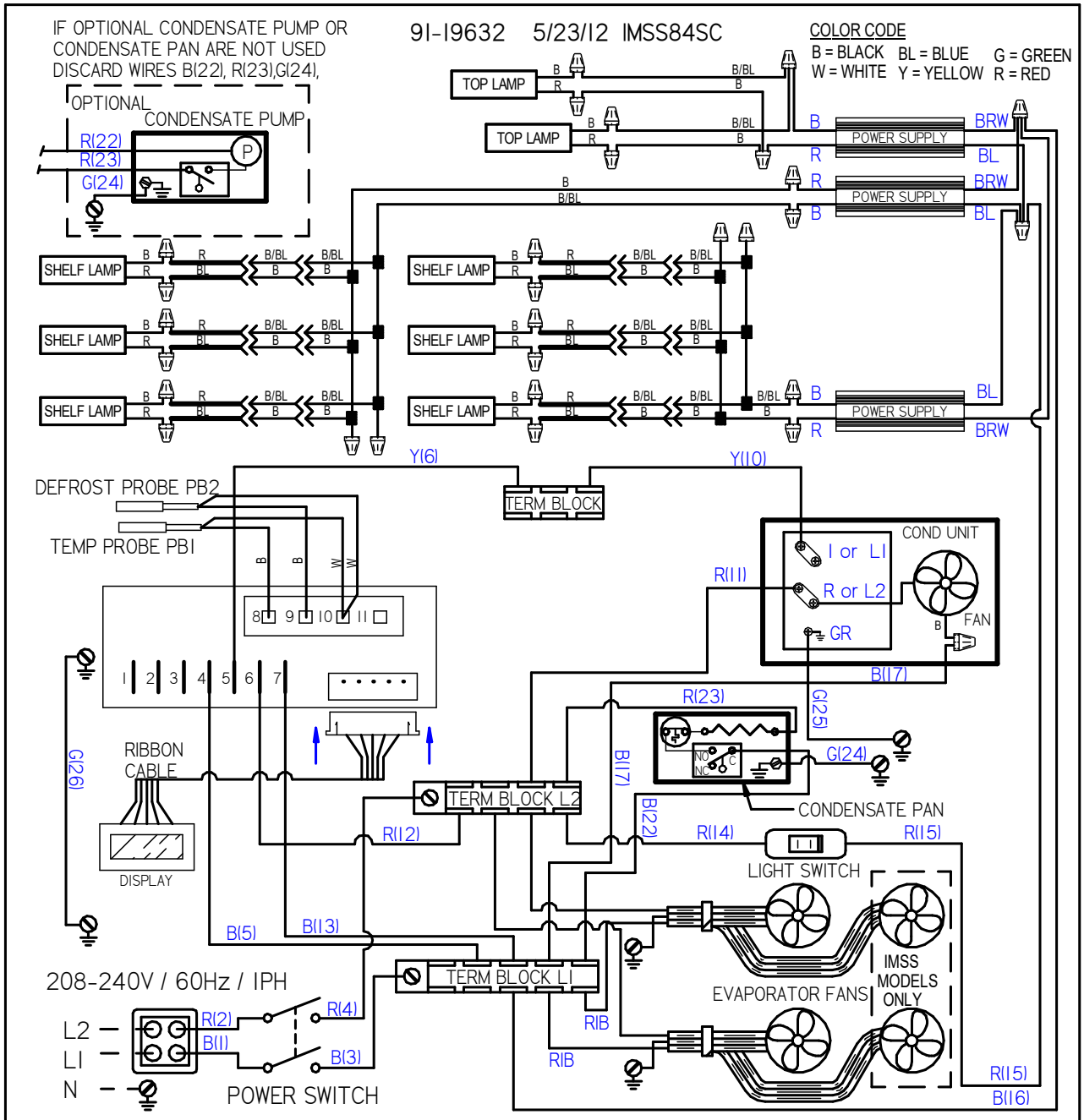

Self-Contained IMSS84SC BETWEEN 8/1/14 – 5/1/18

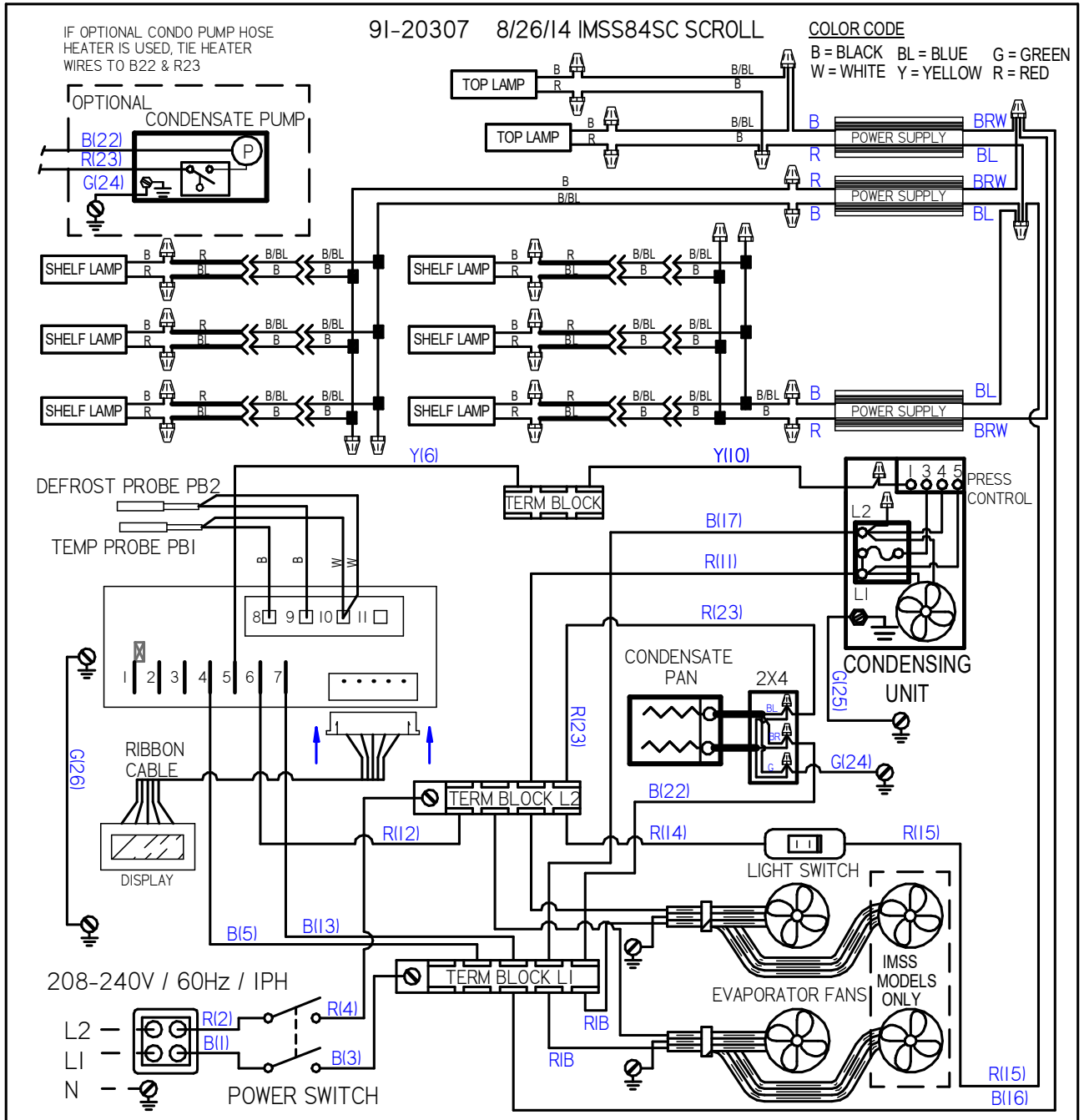

Self-Contained IMSS84SC BETWEEN 5/1/18 & 2/15/18

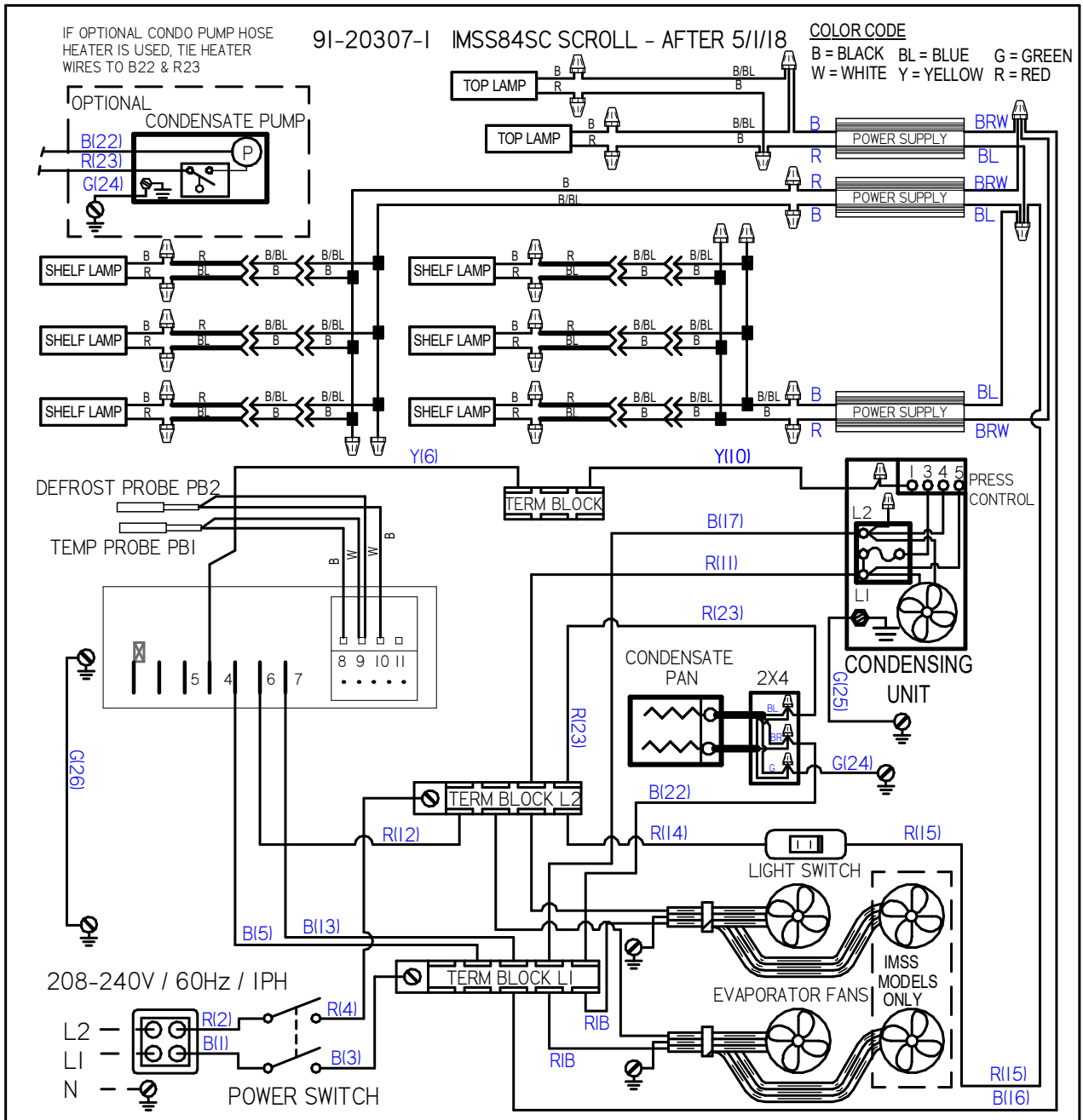

Self-Contained IMSS84SC AFTER 12/1/19

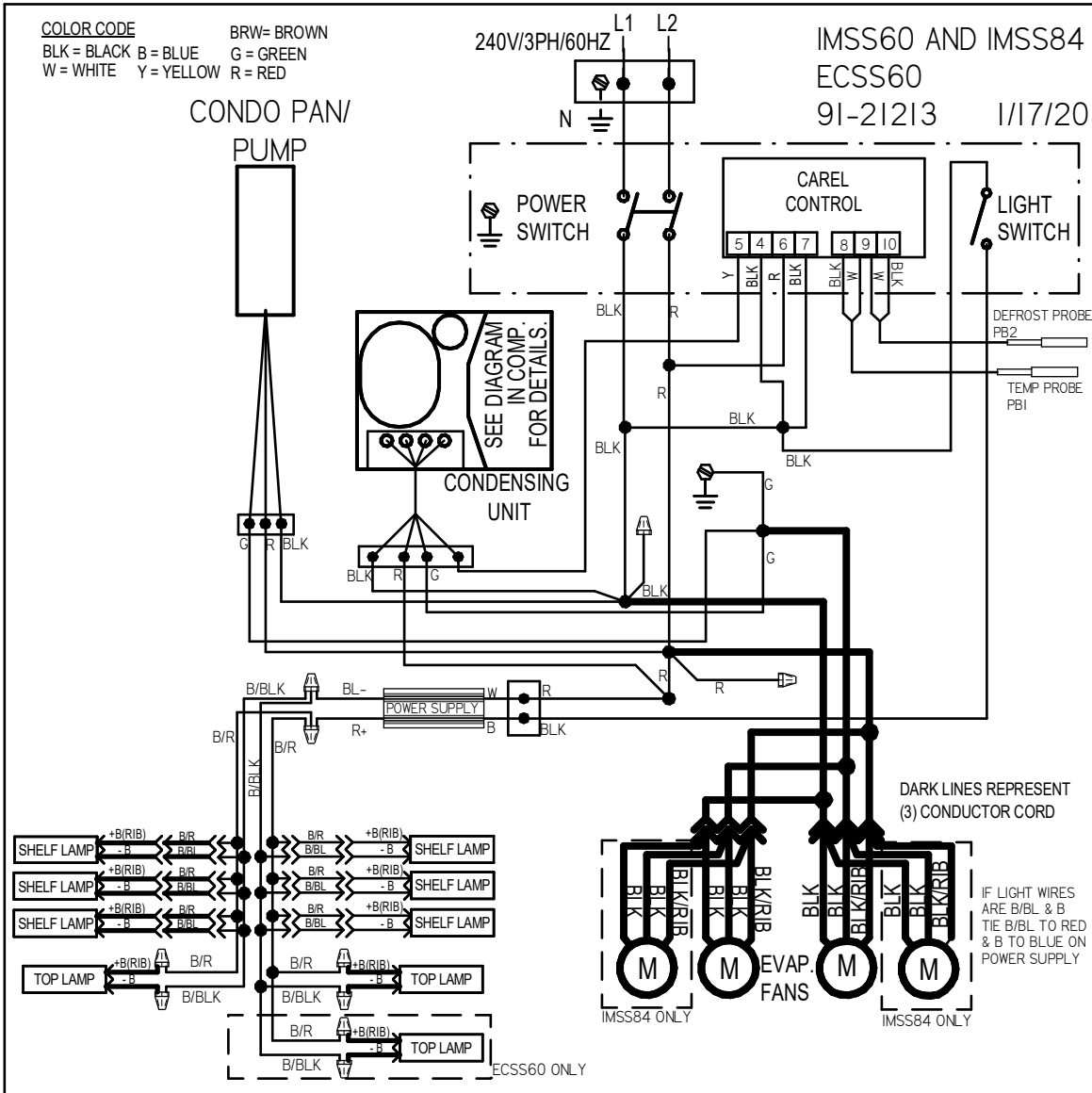

Self-Contained IMSS120SC BEFORE 9/1/14

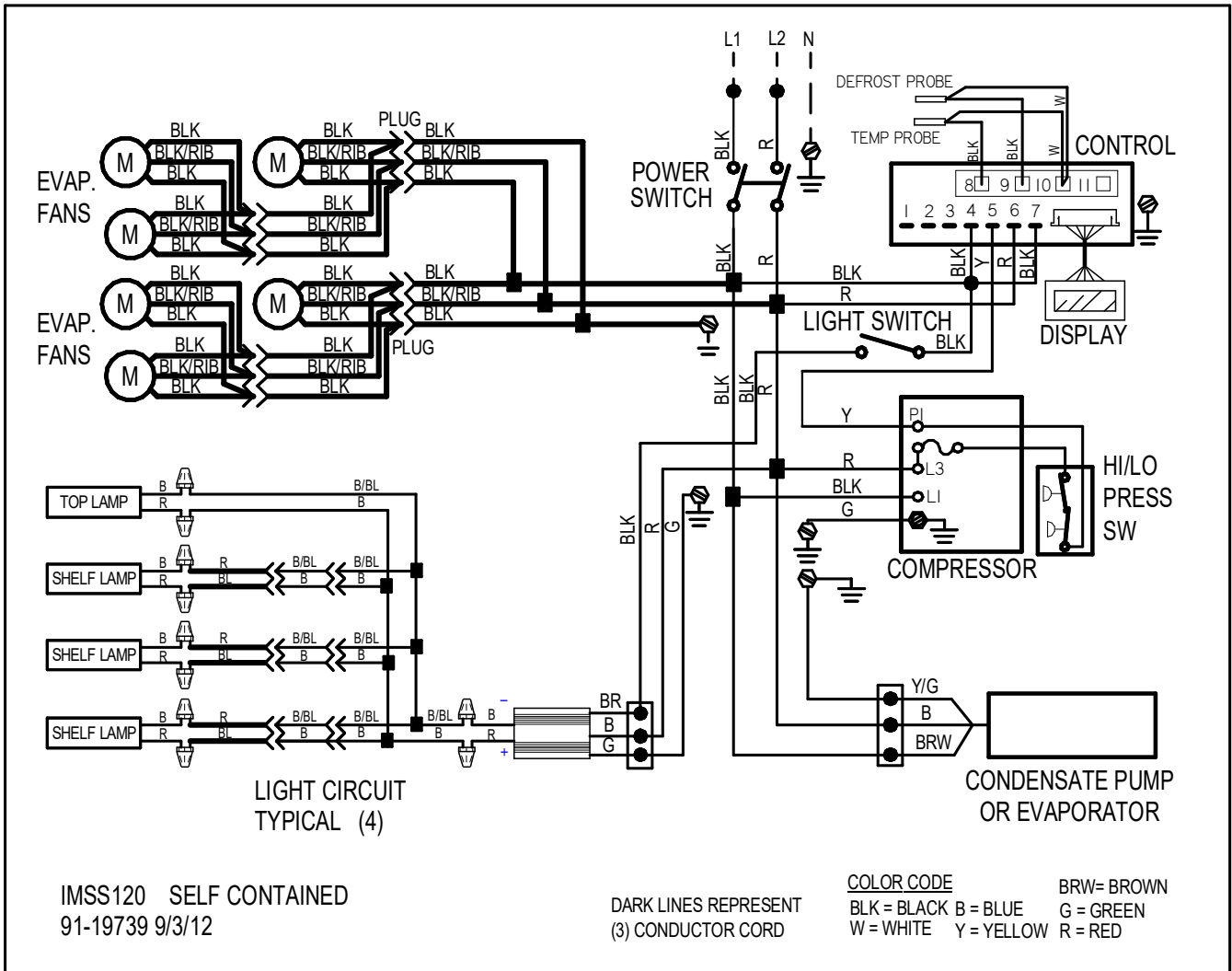

Self-Contained IMSS120SC BETWEEN 9/1/14 & 5/1/18

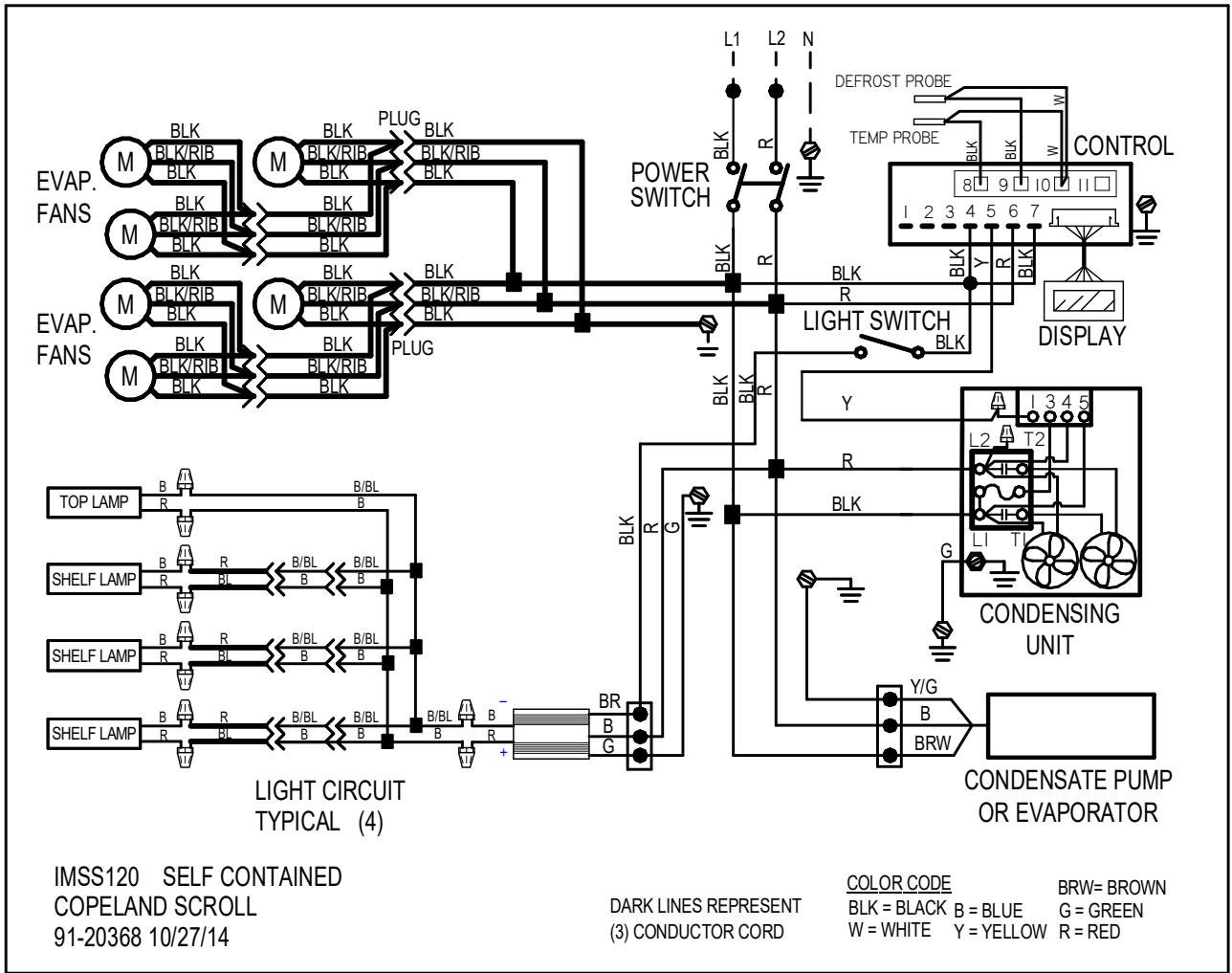

Self-Contained IMSS120SC BETWEEN – 5/1/18 & 12/15/18

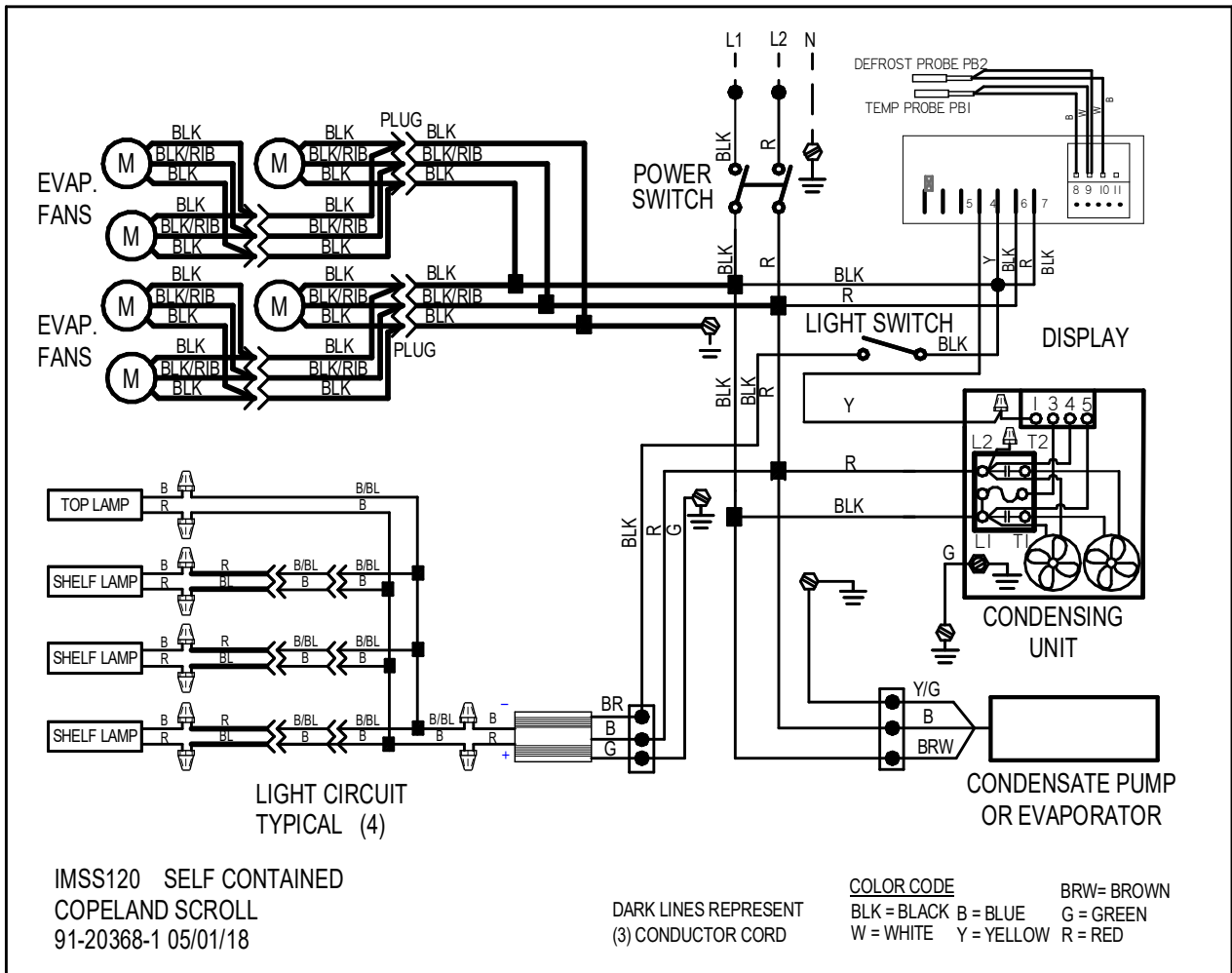

Self-Contained IMSS120SC AFTER – 12/15/18

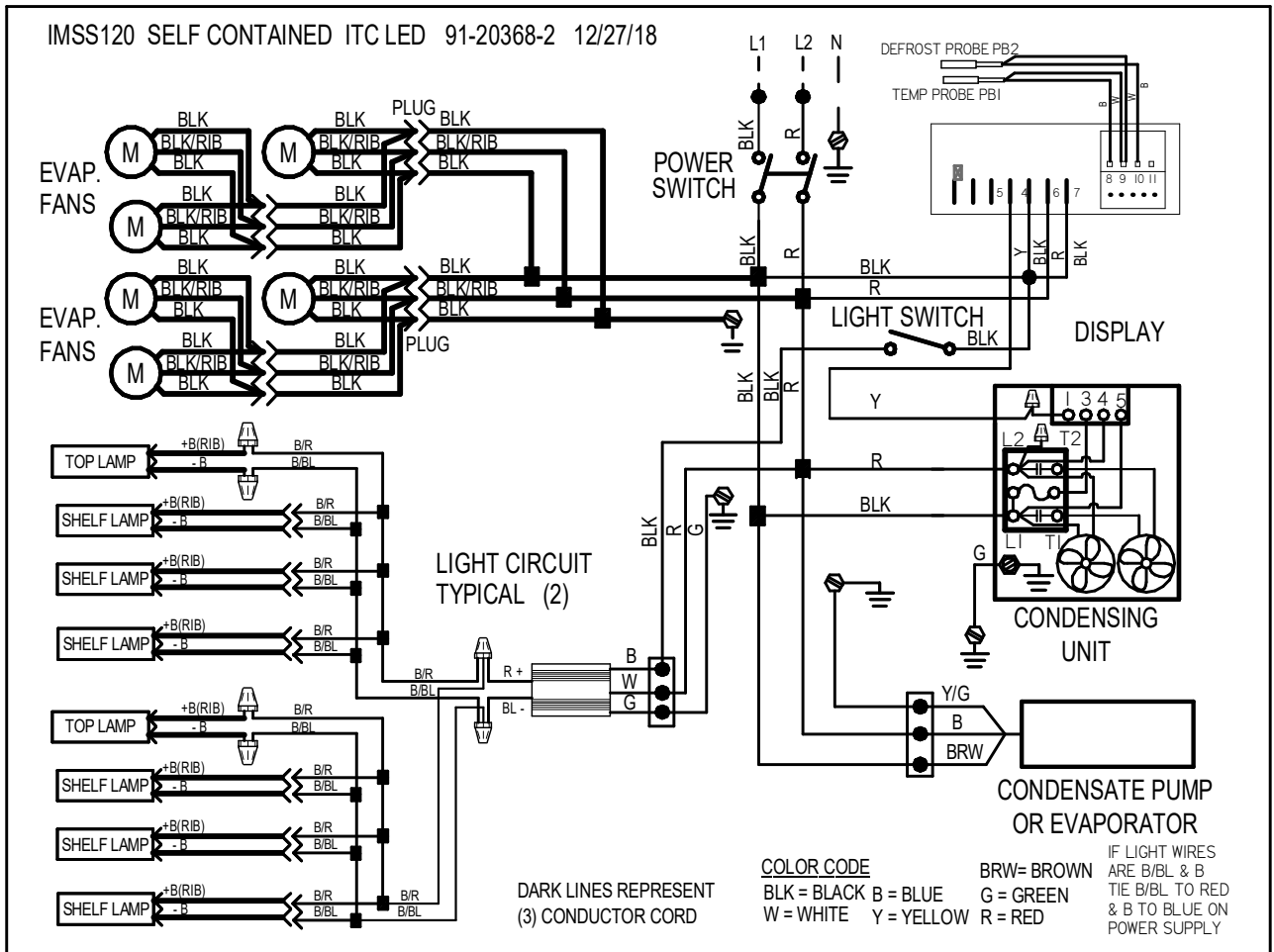

Self-Contained IMSS120SC AFTER – 12/1/19

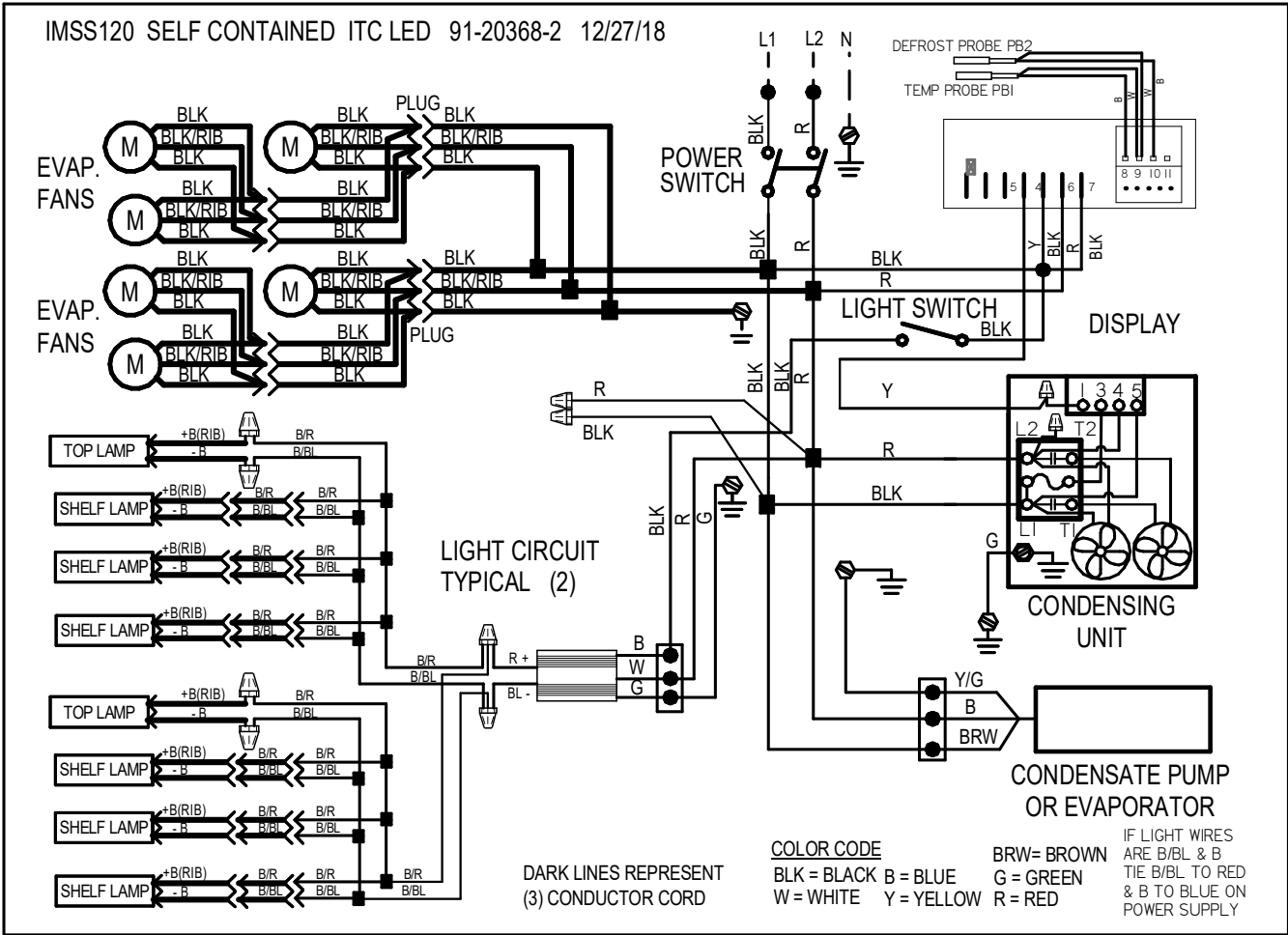

Remote IMSS60R BEFORE 5/23/12

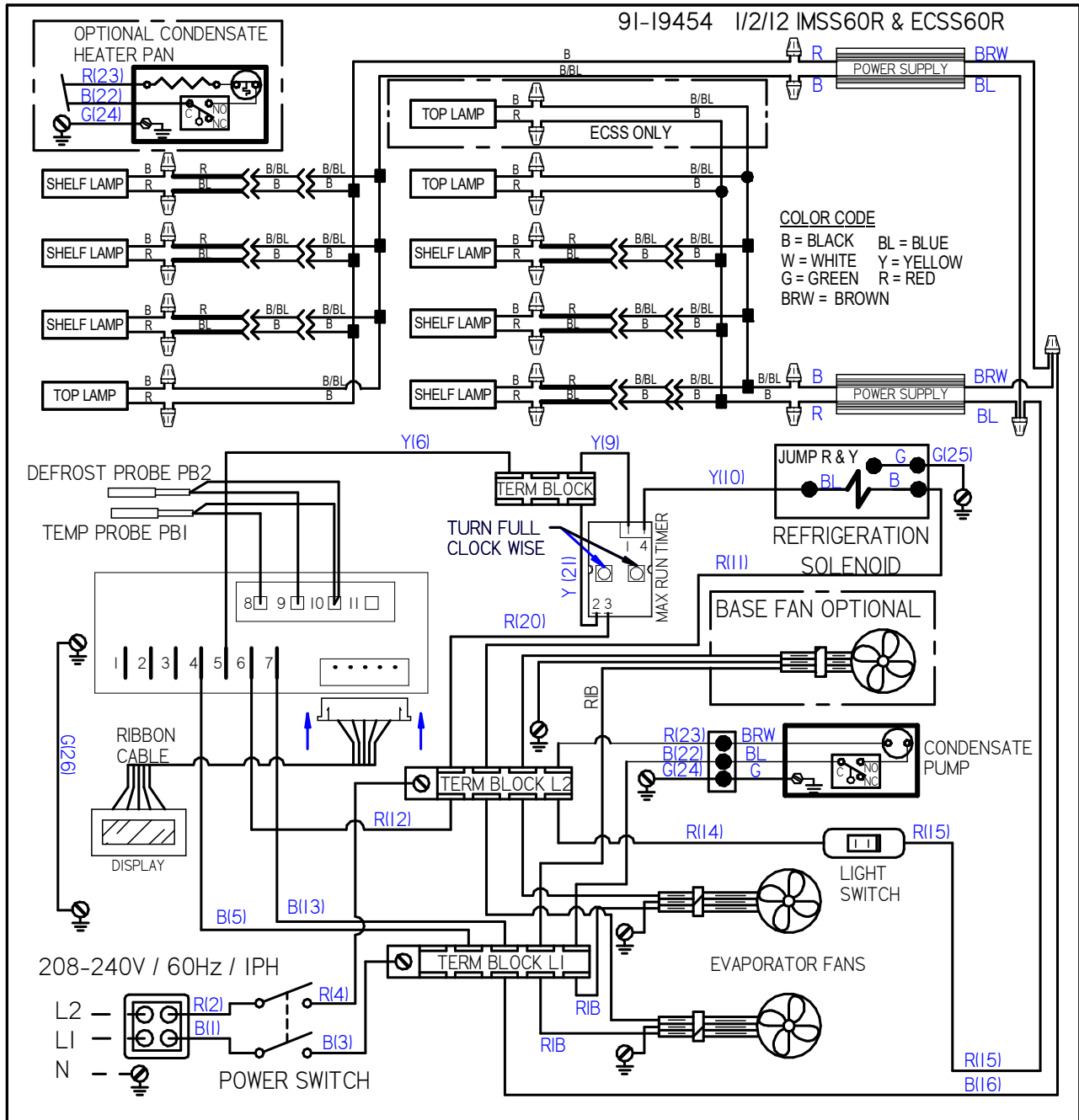

Remote IMSS60R BETWEEN 5/23/12 & 5/1/18

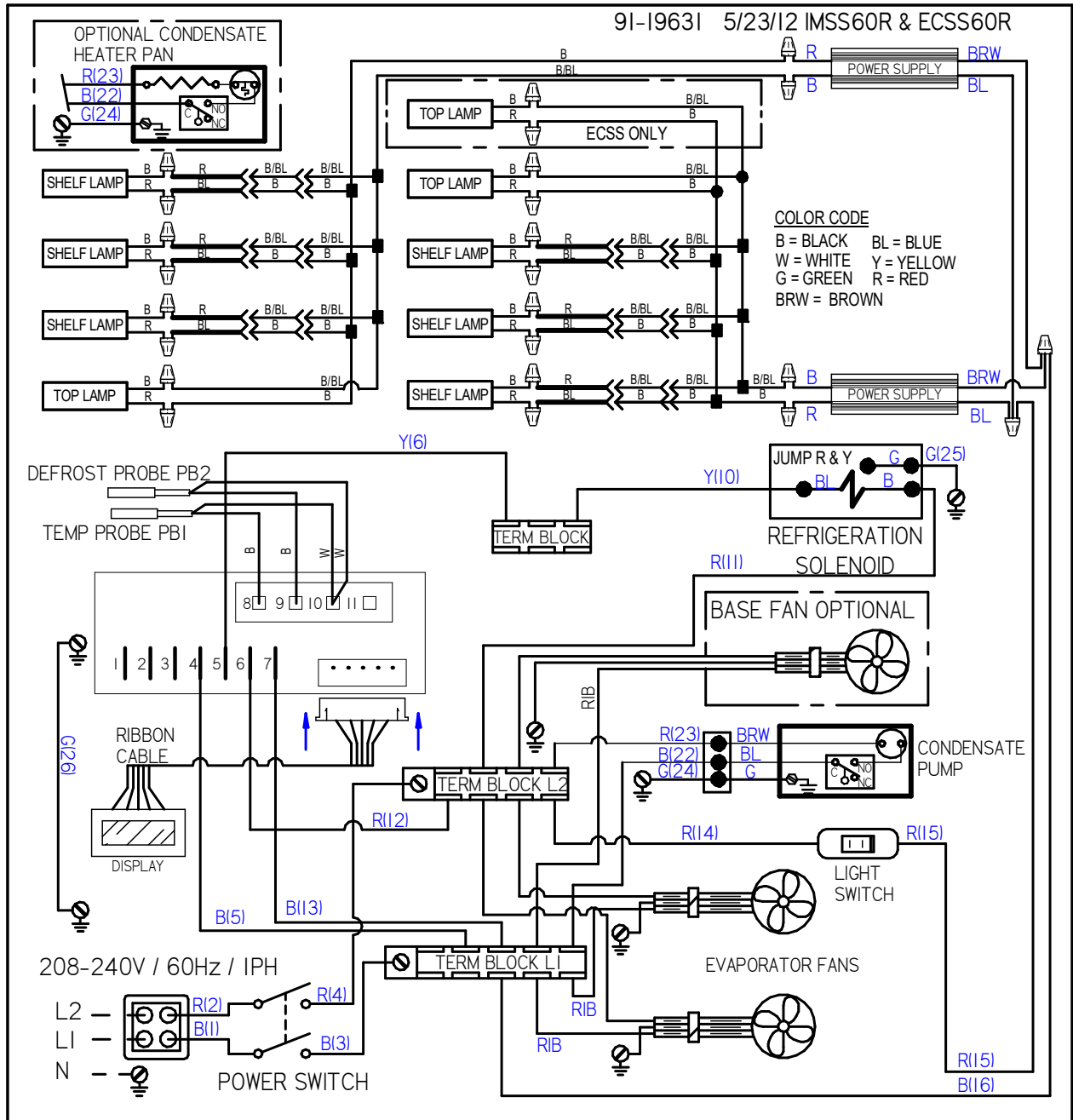

Remote IMSS60R BETWEEN 5/1/18 & 12/15/18

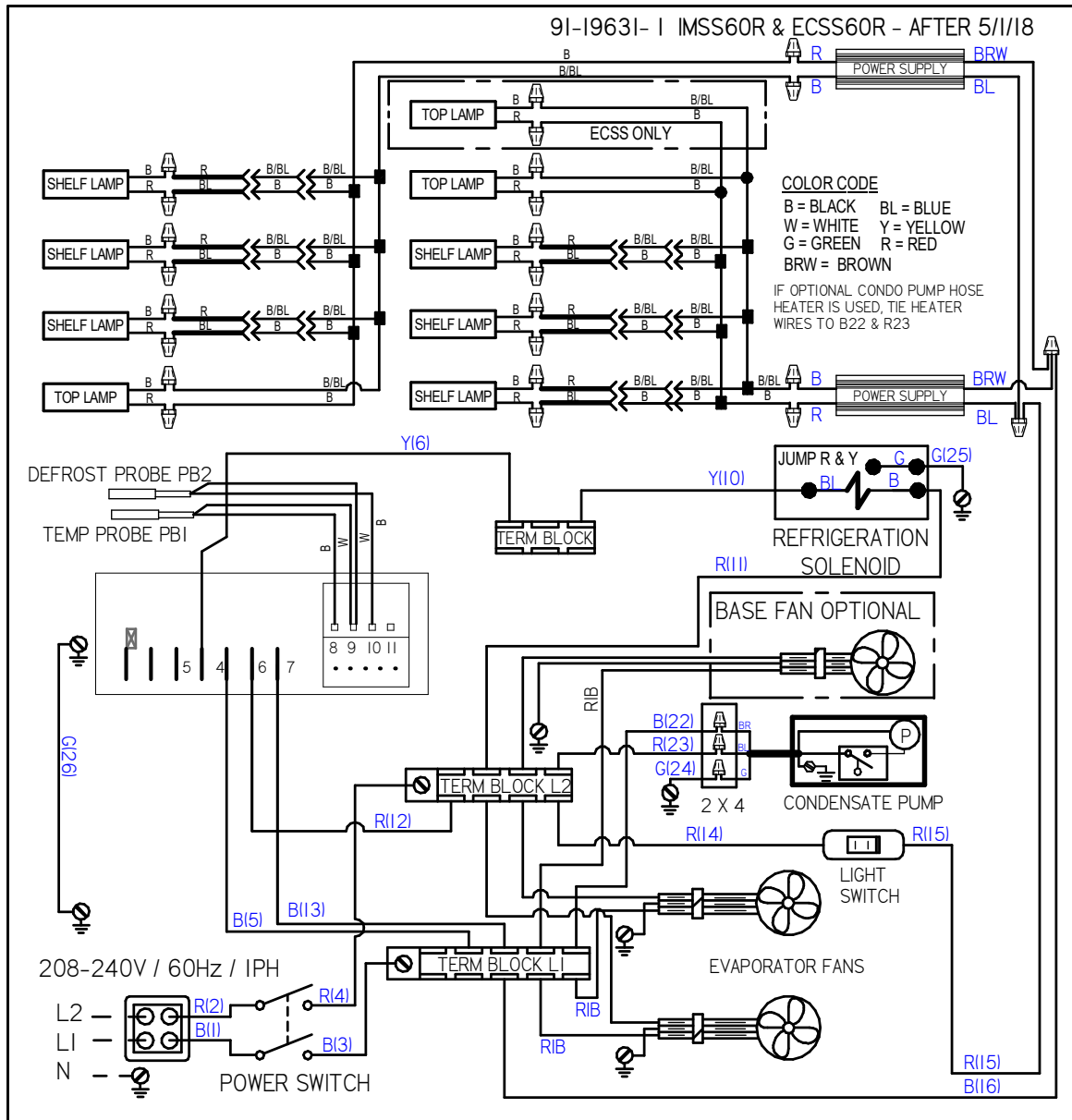

Remote IMSS60R AFTER 12/1/19

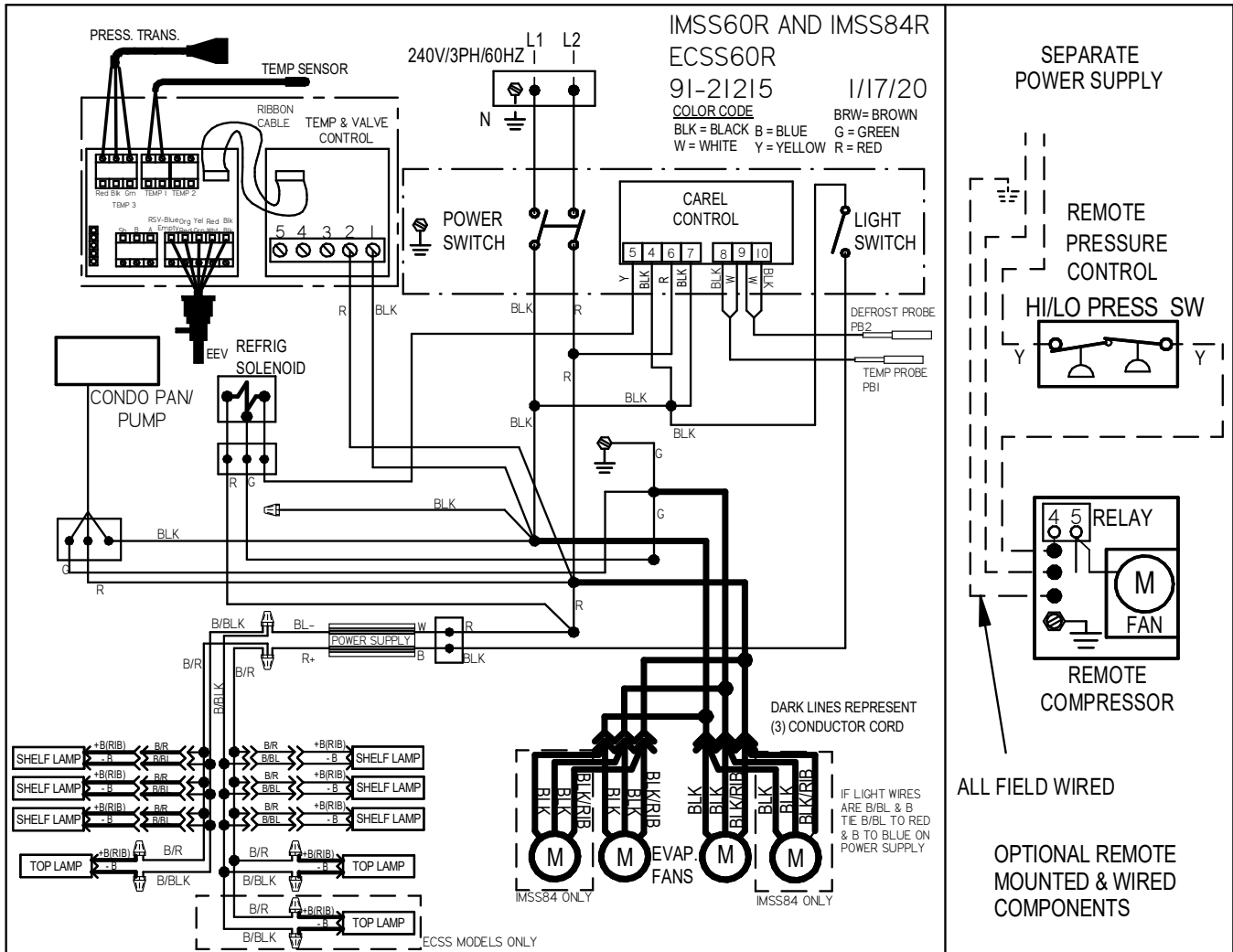

Remote IMSS84R BEFORE 5/23/12

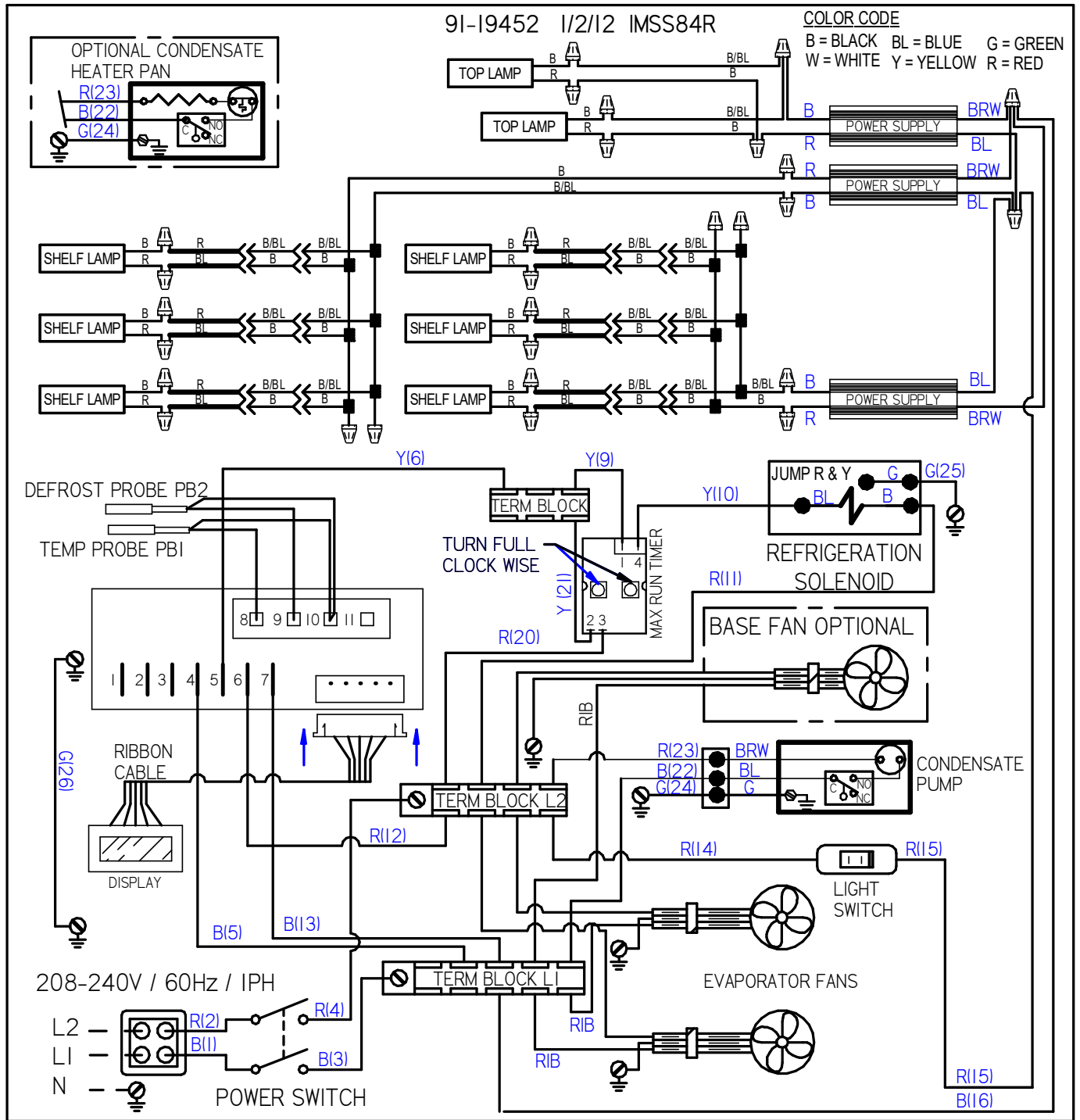

Remote IMSS84R BETWEEN 5/23/12 & 5/1/18

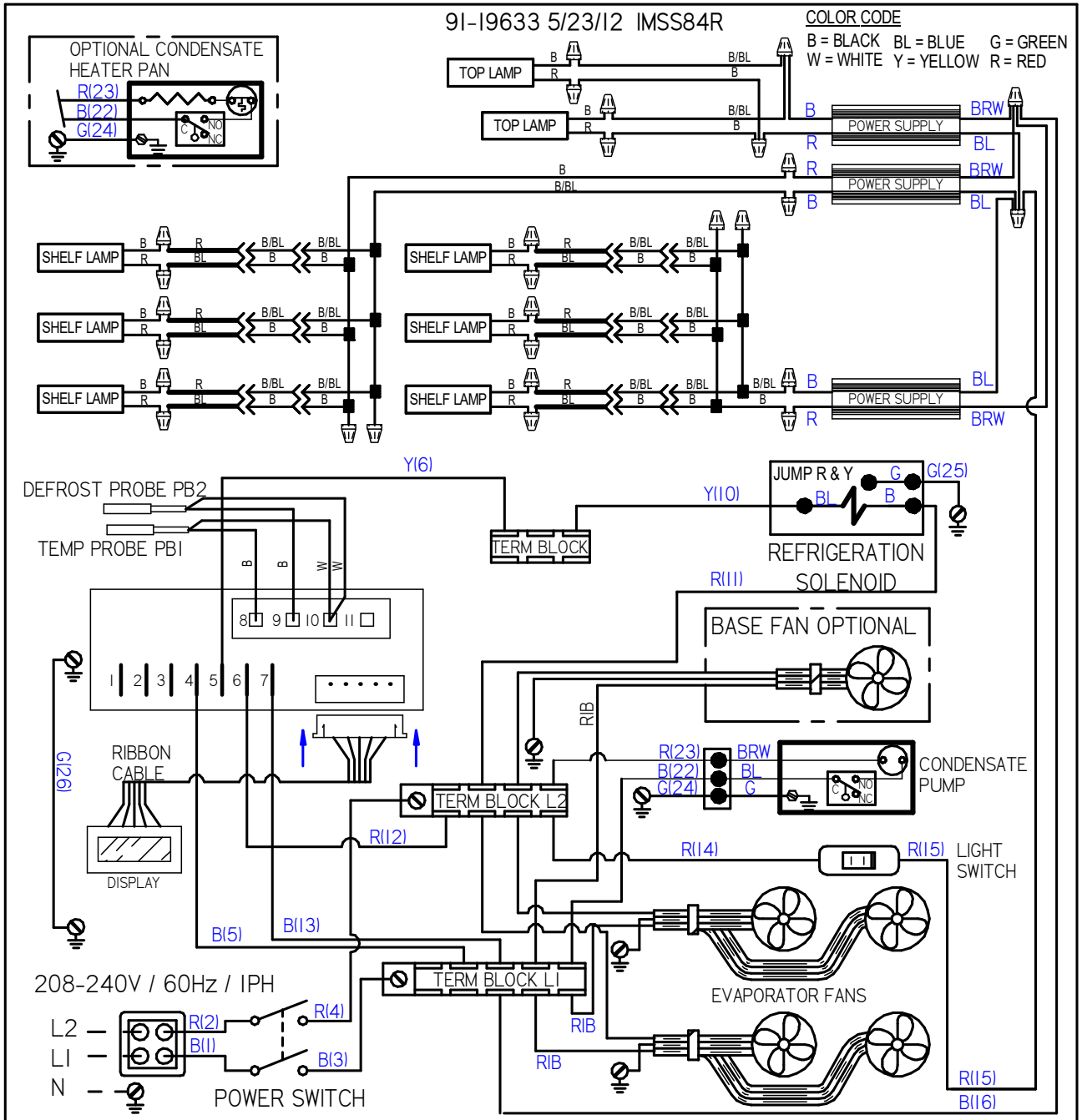

Remote IMSS84R BETWEEN 5/1/18 & 12/15/18

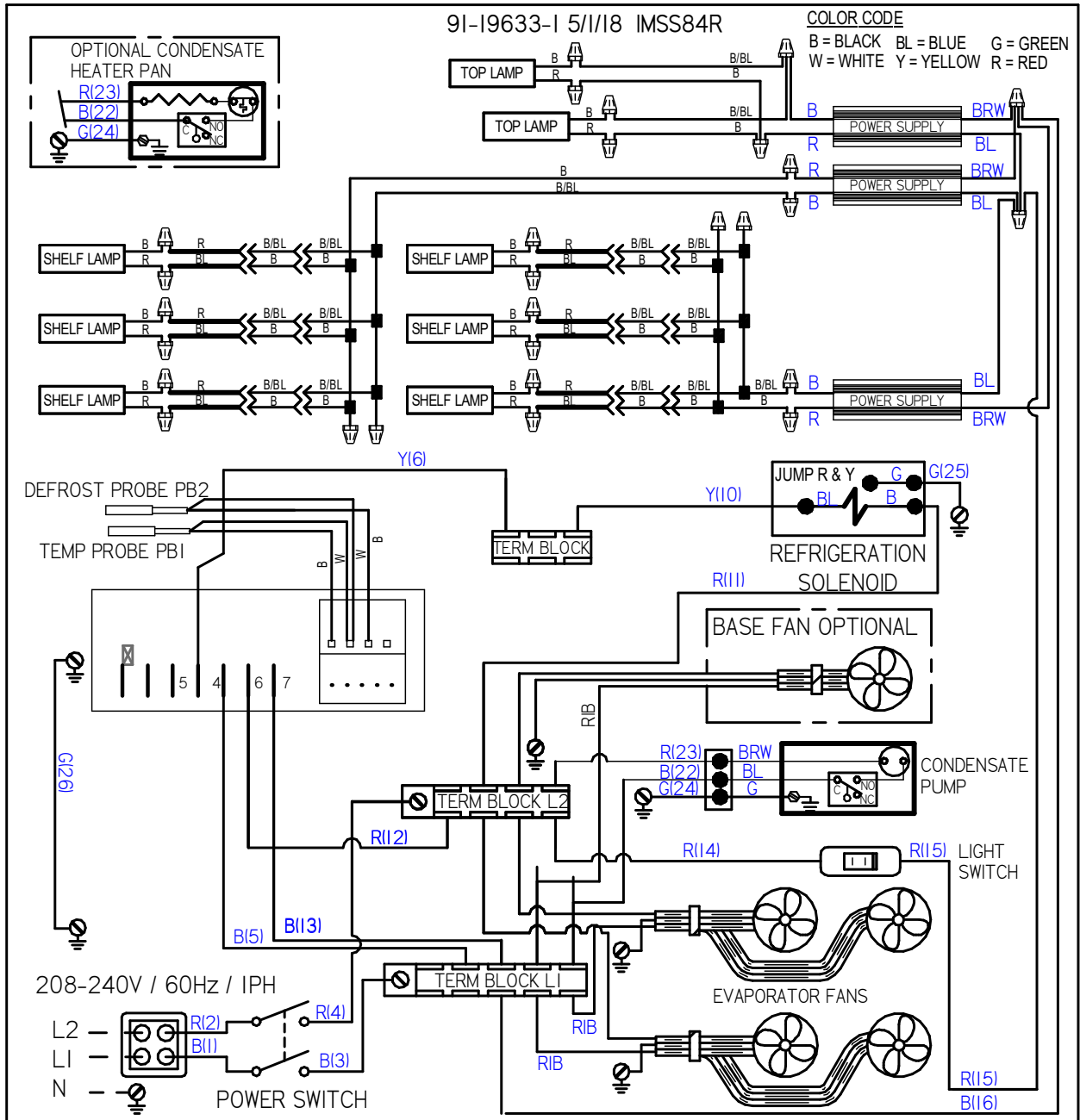

Remote IMSS84R BETWEEN 12/15/18 & 12/1/19

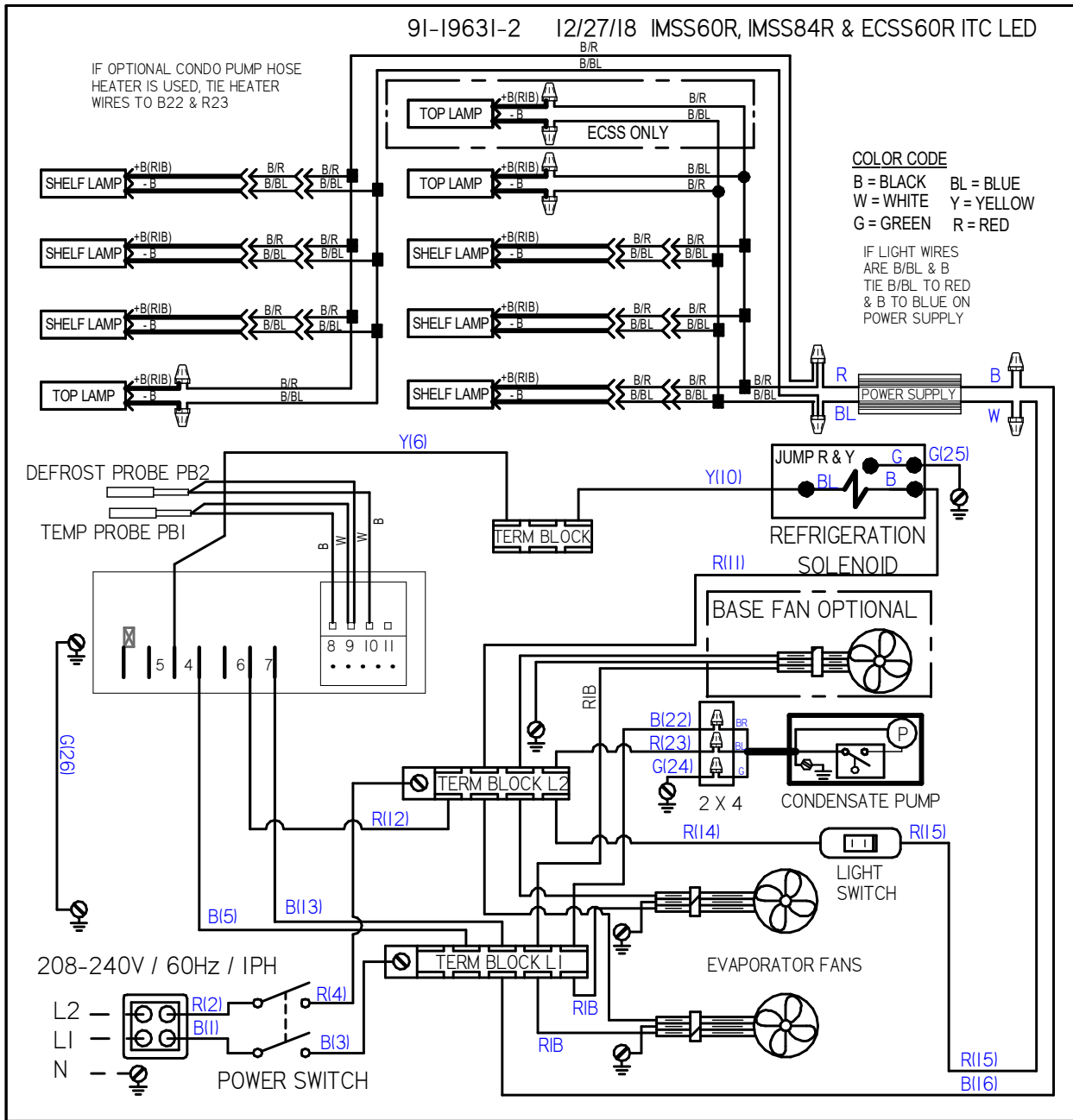

Remote IMSS84R AFTER 12/1/19

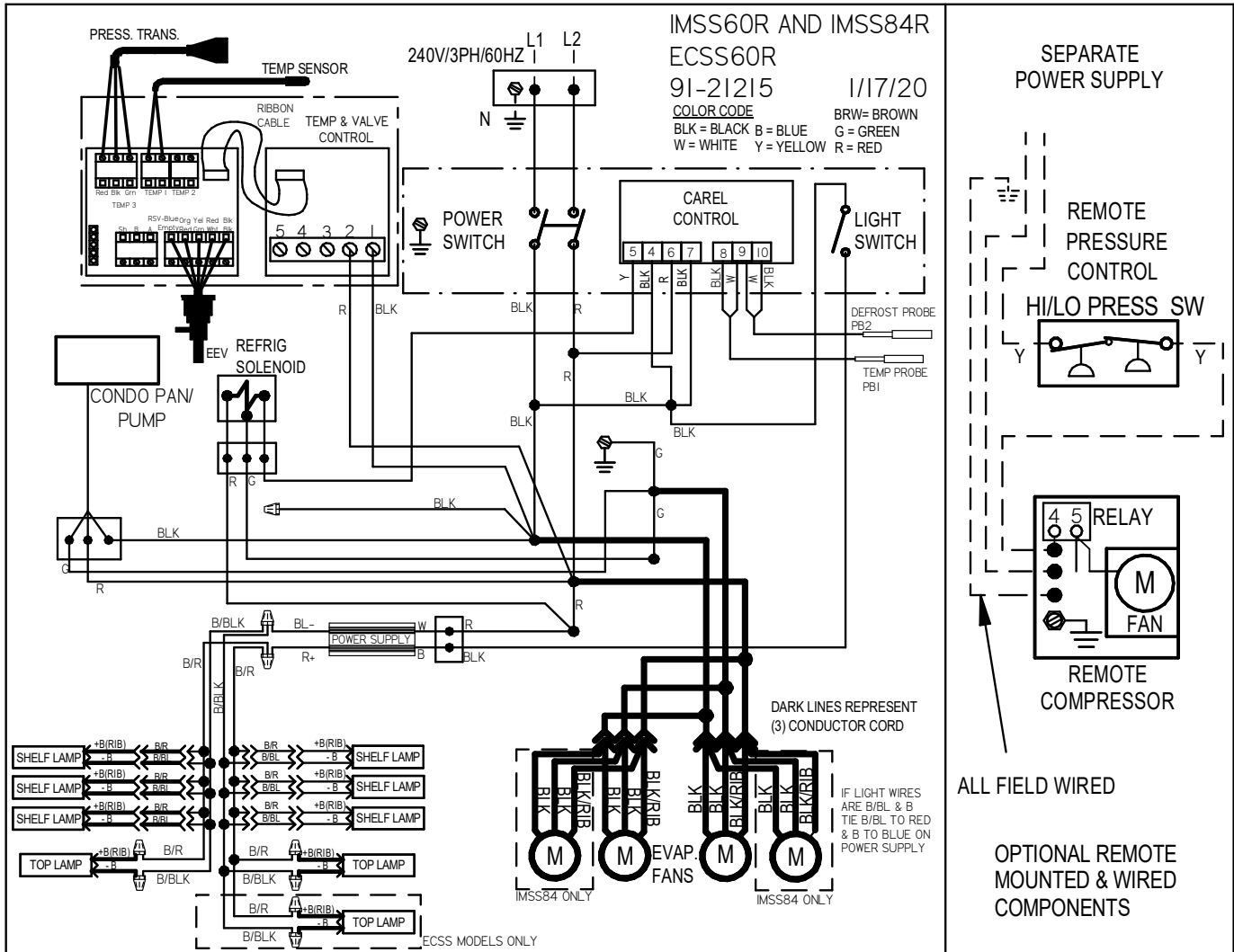

Remote IMSS120R BEFORE 5/1/18

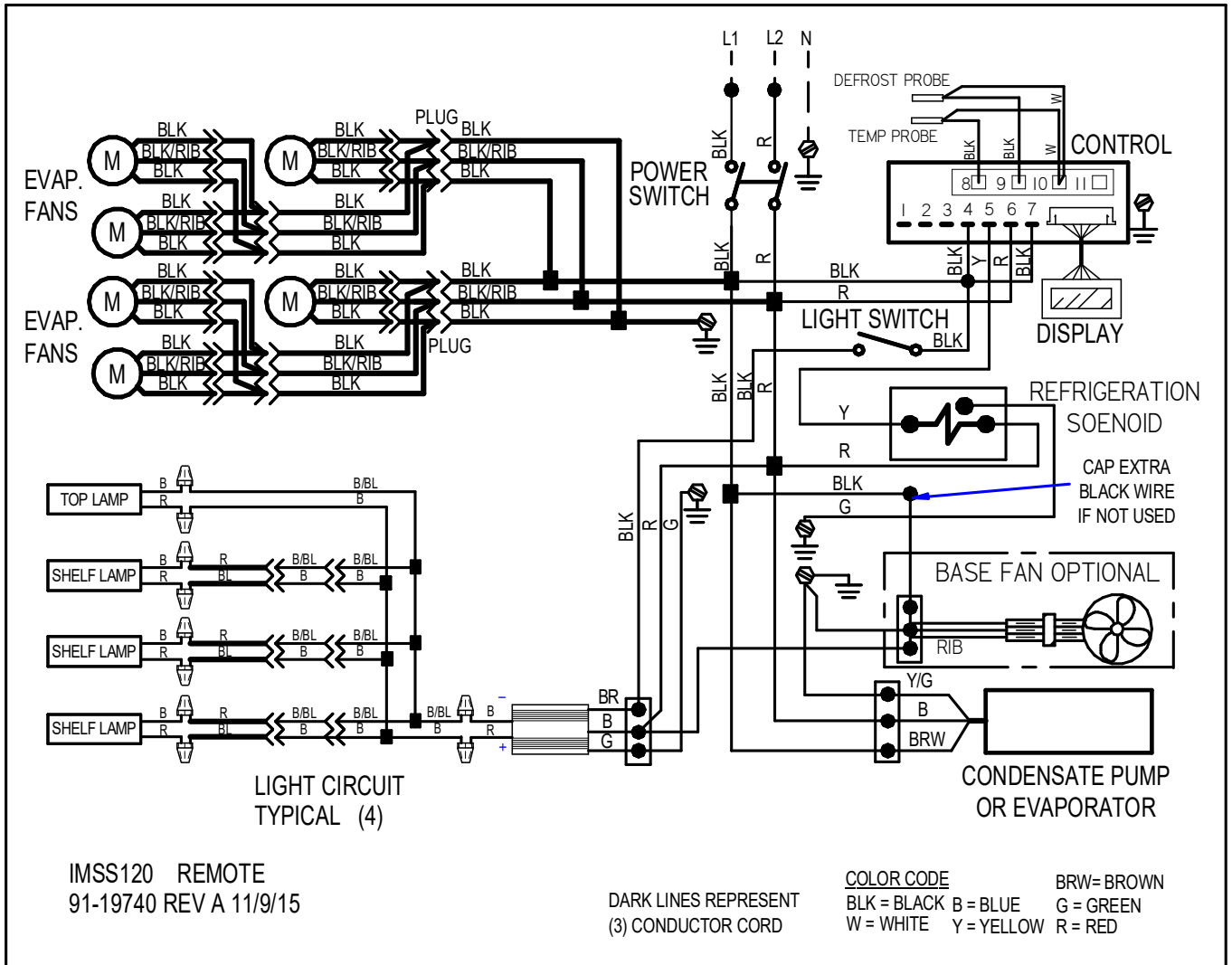

Remote IMSS120R BETWEEN 5/1/18 & 12/15/18

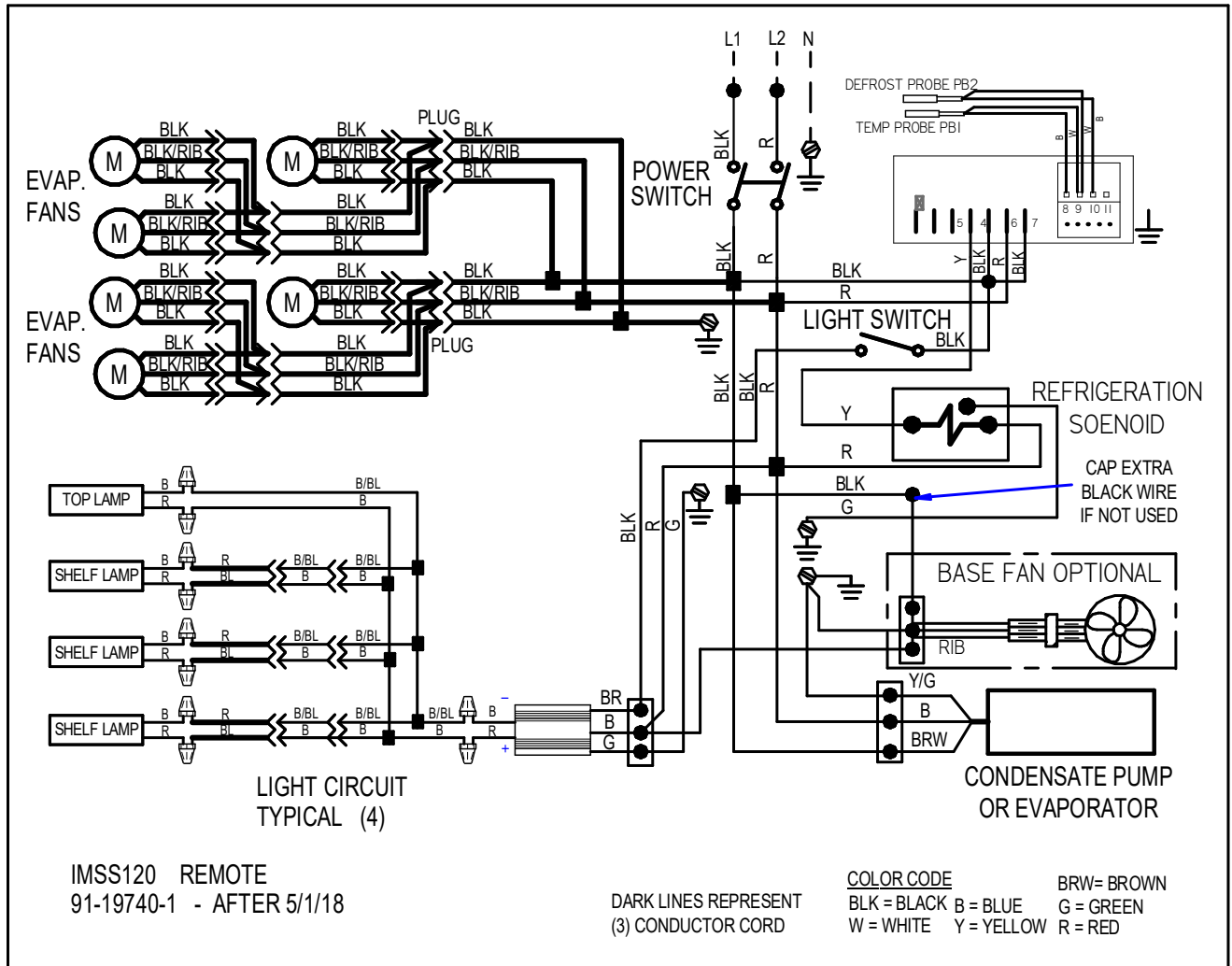

Remote IMSS120R AFTER 12/15/18

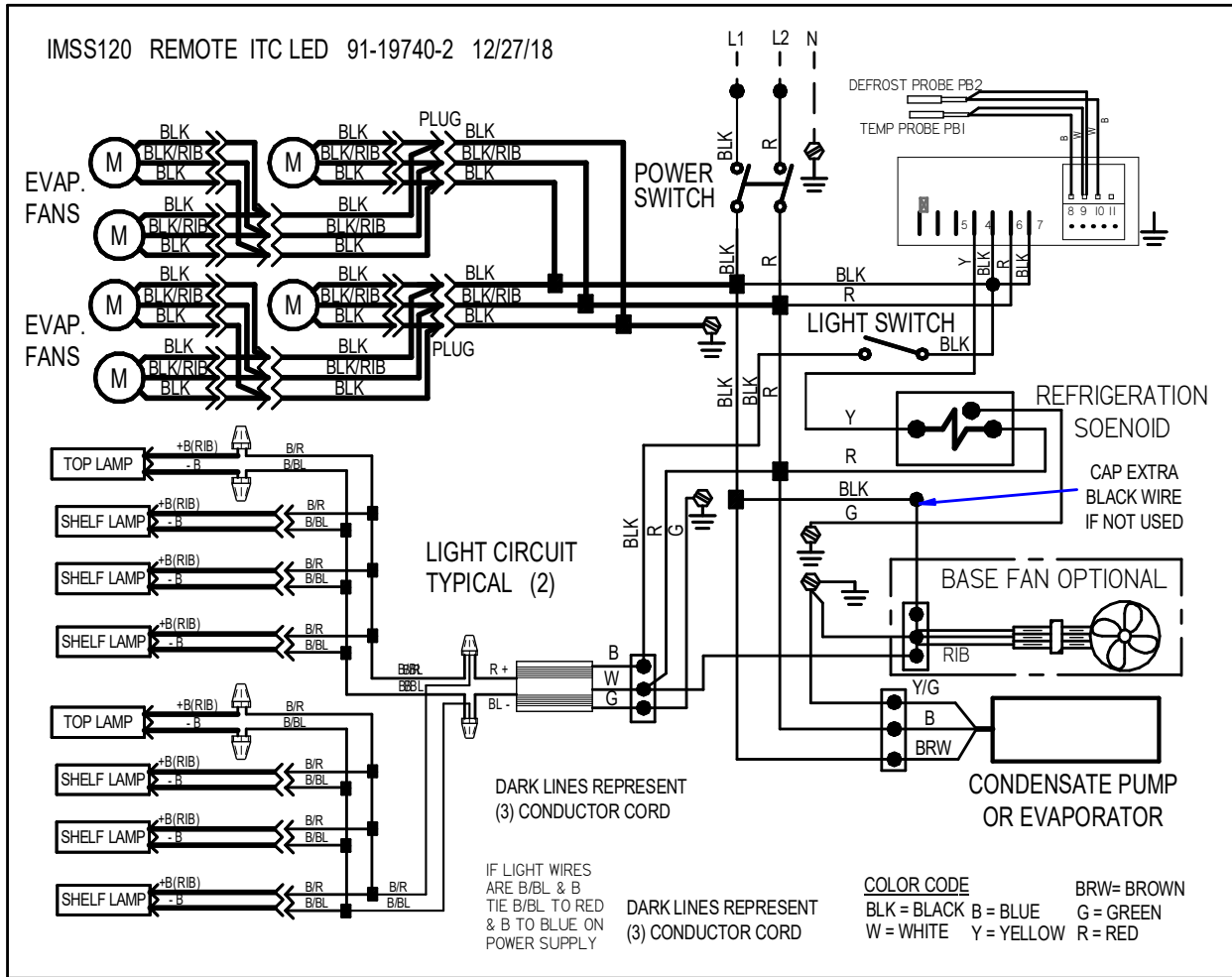

Remote IMSS120R AFTER 12/1/19

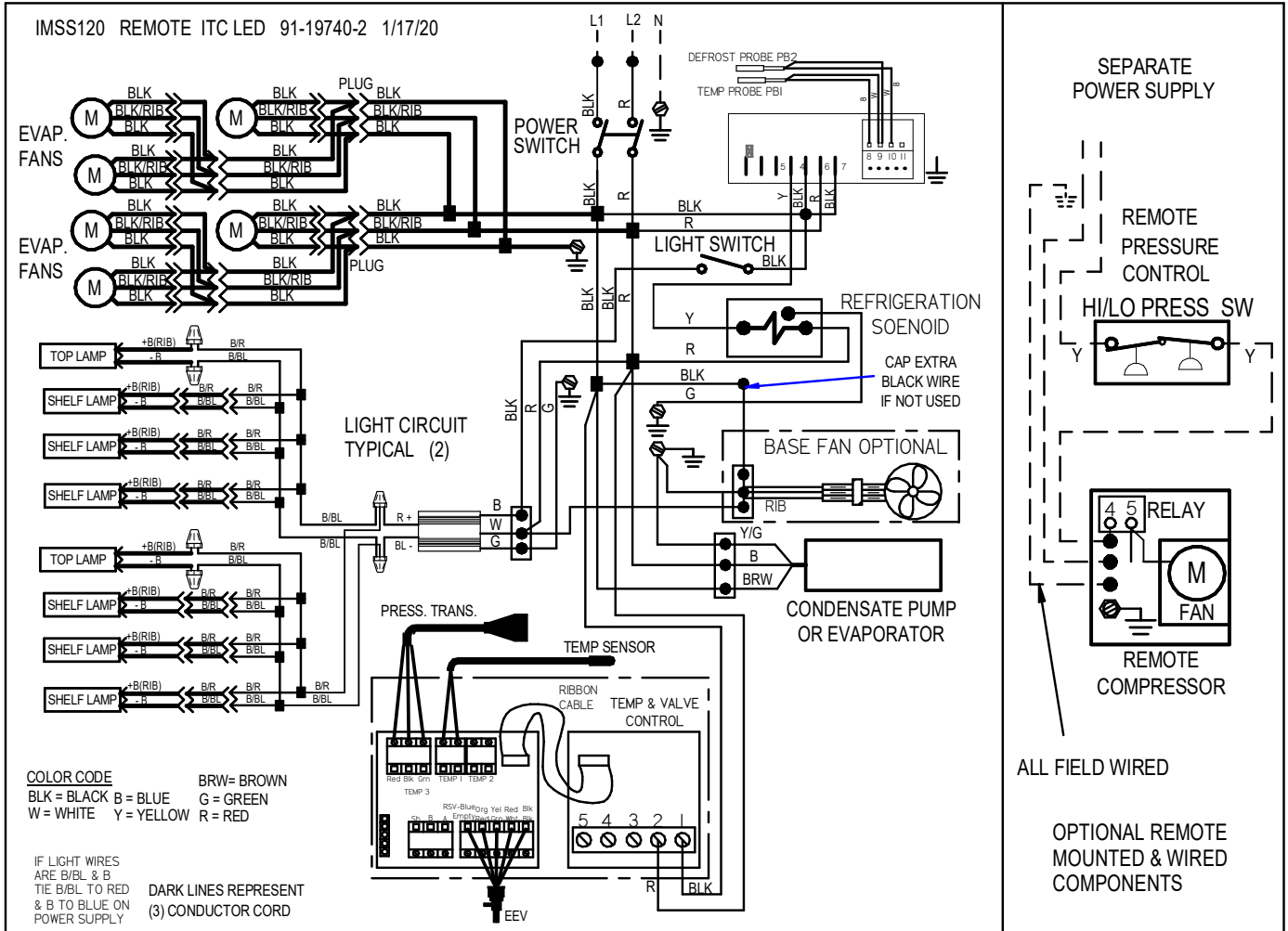

California Residents Only.

⚠ **WARNING**

This product can expose you to chemicals including chromium which is known to the State of California to cause cancer and birth defects or other reproductive harm. For more information

go to www.P65Warnings.ca.gov

