

E3940
2/10/20



The Signature of Quality®

SN-4CD-SS, SN-6CD-SS, SN-8CD-SS

Self-Contained & Remote Models

INSTALLATION & OPERATION INSTRUCTIONS



KEEP THIS MANUAL FOR FUTURE REFERENCE

Engineering and technical data are subject to change without notice.

FEDERAL INDUSTRIES
Toll Free 1(800)256-4206

215 Federal Avenue
WI Phone (608)424-3331

Belleville, WI 53508
Fax: (608)424-3234

Contents

INTRODUCTION.....	3
WARNING LABELS & SAFETY INSTRUCTIONS.....	4
PRE-INSTALLATION PROCEDURES.....	5
INSPECTION FOR SHIPPING DAMAGE.....	5
INSTALLATION INSTRUCTIONS.....	5
LOCATING THE DISPLAY CASE.....	5
REMOVING CASE FROM SHIPPING SKID.....	6
REMOVING PACKAGING MATERIAL.....	6
LEVELING THE CASE.....	6
REFRIGERATION INSTALLATION.....	7
GRILL REMOVAL.....	8
CONDENSATE EVAPORATOR.....	8
DISPLAY COMPONENT CHECK.....	9
CLEANING.....	9
ELECTRICAL INFORMATION & GROUNDING.....	10
OPERATING INSTRUCTIONS.....	11
INITIAL START-UP.....	11
CONTROLS.....	11
PLACING PRODUCT INTO CASE.....	12
PERIODIC MAINTENANCE.....	12
CLEANING INSTRUCTIONS.....	13
DAILY CLEANING.....	13
WEEKLY CLEANING.....	13
INTERIOR CLEANING.....	14
EXTERIOR CLEANING.....	14
SERVICE INFORMATION.....	15
PRE-SERVICE CHECKLIST.....	16
SPECIAL SERVICE SITUATIONS.....	17
SALE & DISPOSAL.....	17
OWNER RESPONSIBILITY.....	17
SELF-CONTAINED REFRIGERATION & ELECTRICAL DATA.....	18
REMOTE REFRIGERATION & ELECTRICAL DATA (OBS 1/1/2012)	19
REPLACEMENT PARTS.....	20
REPLACEMENT PARTS.....	21
WIRING DIAGRAM- MAIN WIRING SELF-CONTAINED.....	22
WIRING DIAGRAM- SN4CD-SS & SN6CD-SS.....	23
WIRING DIAGRAM- SN8CD-SS.....	24

INTRODUCTION

Thank you for purchasing a Federal Industries display case. This manual contains important instructions for installing and servicing the Series '90 Refrigerated Self-Serve Bakery/Deli Display Cases. A repair parts list and wiring diagram are also included in the manual. Read all of these documents carefully before installing or servicing your case.



NOTICE

Read this manual before installing your case. Keep this manual and refer to it before doing any service on the equipment. Failure to do so could result in personal injury or damage to the case.



NOTICE

Installation and service of the electrical components in the case must be performed by a licensed electrician.

The portions of this manual covering electrical components contain technical instructions intended only for persons qualified to perform electrical work.



DANGER

Improper or faulty hookup of electrical components in the case can result in severe injury or death.

All electrical wiring hookups must be done in accordance with applicable local, regional, or national standards.

REGISTRATION & SERIAL NUMBER

It's important to keep a record of the model and serial number of your merchandiser for warranty and part identification. Please write them here for your quick reference.

Register your product online! Visit our website at www.federalindustries.com and register your product today.

Case Model _____ Serial Number _____

We're here to provide you with the best possible experience with your new product, however, we cannot cover everything about your merchandiser in this manual, so if you have any additional questions or issues, please see the SERVICE INFORMATION PAGE to find who you should contact.

WARNING LABELS & SAFETY INSTRUCTIONS



This is the safety-alert symbol. When you see this symbol on your case or in the manual, be alert to the potential for personal injury or damage to your equipment.

Be sure you understand all safety messages and always follow recommended precautions and safe operating practices.



Notice to Employers

You must make sure that everyone who installs, uses, or services your case is thoroughly familiar with all safety information and procedures.

Important safety information is presented in this section and throughout the manual. The following signal words are used in the warnings and safety messages:

DANGER: Severe injury or death will occur if you ignore the message.

WARNING: Severe injury or death can occur if you ignore the message.

CAUTION: Minor injury or damage to your case can occur if you ignore the message.

NOTICE: This is important installation, operation, or service information. If you ignore the message, you may damage your case.

The warning and safety labels shown throughout this manual are placed on your Federal Industries case at the factory. Follow all warning label instructions. If any warning or safety labels become lost or damaged, call our customer service department at 1(800)356-4206 for replacements.



This label is located on the back of the display case.

CAUTION
**HAZARDOUS MOVING PARTS.
DO NOT OPERATE UNITE WITH
DISPLAY PANS REMOVED.**

This label is located below the display pan.

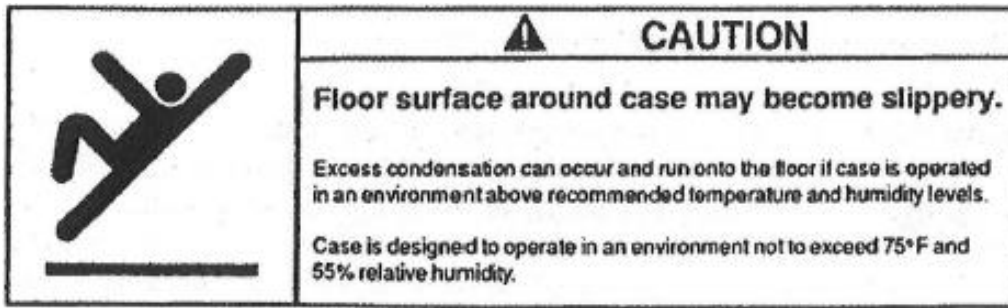

This label is located on the back of the display case.

PRE-INSTALLATION PROCEDURES

Inspection for Shipping Damage

You are responsible for filing all freight claims with the delivering truck line. Inspect all cartons and crates for damage as soon as they arrive. If damage is noted to shipping crates or cartons or if a shortage is found, note this on the bill of lading (all copies) prior to signing.

If damage is discovered when the case is uncrated, immediately call the delivering truck line and follow up the call with a written report indicating concealed damage to your shipment. Ask for an immediate inspection of your concealed damage item. Crating material must be retained to show the inspector from the truck line.

INSTALLATION INSTRUCTIONS

Locating the Display Case

The case should be located where it is not subjected to the direct rays of the sun, heating ducts, grills, radiator, or ceiling fans, nor should it be located near open doors or main door entrances. Also, avoid locations where there is excessive air movement or air disturbances. Failure to do this will cause warm interior case temperature.

The condenser air inlet is located at the rear of the case. Do not block this inlet and do not locate the air inlet near a source of heat.

Removing Case from Shipping Skid

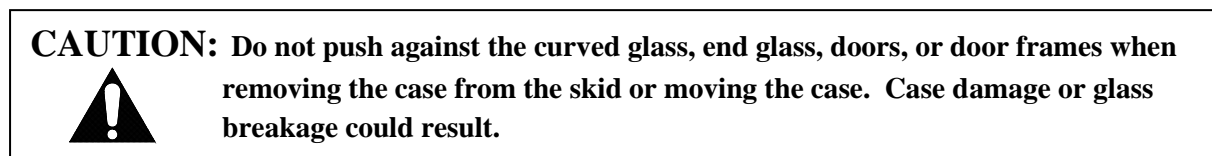

Move the case as near as possible to the final location before removing it from the shipping skid.

Remove the four (4) bolts that secure the case to the skid. **DO NOT REMOVE THE SHIPPING BRACKETS FROM THE CASE. THE BRACKETS ARE INTENDED TO BE USED AS HAND GRIPS FOR LOCATING THE CASE.** Remove the brackets when the case is in the final location.

Removing Packaging Material

Remove the brackets that held the case to the shipping skid.

Remove the shipping tape that secures the doors and lift-up glass. If it is necessary to remove tape residue from plastic materials, use cleaning compounds recommended in the cleaning section of this manual.

Leveling the Case

The case must be level for proper drainage of defrost condensate to the condensate evaporator.

Four (4) leg levelers are provided for leveling the case. The leg levelers can be turned in and the case can be placed with the base frame on the floor.

The leveled case should be sealed to the floor using an NSF Approved sealant.

Refrigeration Installation

Self-Contained Models

The self-contained models are shipped from the factory with a completely operational refrigeration system and require no modifications or adjustments of the system upon installation.

Remote Models (Obsolete as of 1/1/2012)

The remote models are designed to use 134A refrigerant and shipped from the factory with the evaporator coil, expansion valve, refrigerant solenoid valve, and thermostat. The thermostat senses interior case temperature and opens and closes the refrigerant solenoid valve as needed to maintain proper case temperatures. The condensing unit is optionally supplied from the factory for remote location installation.

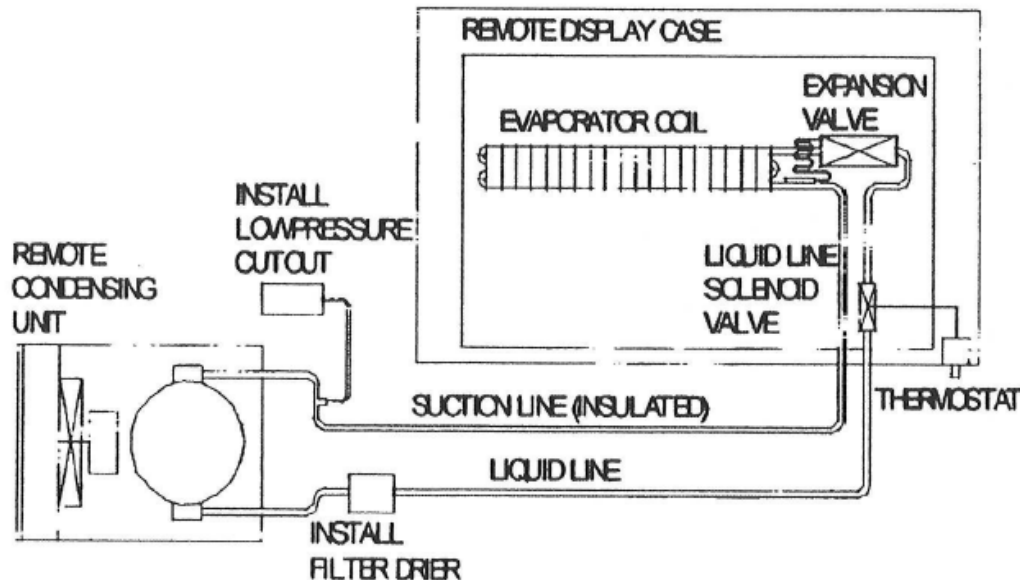

- A. Mount condensing unit indoors as close to the remote display as practical. The refrigeration line should be as short as possible.
- B. All refrigeration and/or electrical materials between the condensing unit and display case are to be supplied by installing contractor.
- C. Route properly sized and designed refrigeration lines from the condensing unit to the cabinet. Horizontal suction lines should be pitched downward towards the condensing unit and least $\frac{1}{2}$ " per 10' run to aid the oil drainage. A "P" trap must be installed in the suction line at the foot of every riser to insure oil return. Dry nitrogen should be used to flow through tubing while brazing refrigeration lines.
- D. Suction line must be insulated the entire length with Armaflex (or equivalent). Do not run liquid line inside insulation with suction line.
- E. The filter drier, sight glass, and low-pressure control are not furnished with remote display case models. The recommended low pressure setting for R134A refrigerant is 32# cut in and 0# cut-out.
- F. Leak check condensing unit, cabinet, and all connecting tubing. Cabinet and condensing unit tubing should be checked to insure no leaks occurred during shipping or from rough handling. Make certain all refrigeration valves are opened and evacuate system to 500 microns. Charge the system with refrigerant type specified on the data plates.

Grill Removal



DANGER: Electric shock hazard. Do not operate unit with panels removed.

The front of the case has a removable base panel to access the front leg levelers of the case. Normally it is not necessary to remove the panel to install the case. This panel must be in place for proper operation of the case.

There are two (2) removable panels on the back of the case. The left side panel allows access to the lamp ballasts, the pullout condensing unit, and the field wiring connection box. Remove this panel to make field wiring connections. The panel must be in place for proper operation of the case.

The right side panel has the temperature display, power switch, and thermostat mounted to it. Removing this panel allows access to the terminal board, branch circuit fuse, condensate evaporator, and compressor service parts. Normally it is not necessary to remove this panel to install the case.

The panel must be in place for proper operation of the case.

Condensate Evaporator

This case is furnished with an electric condensate evaporator. A separate 115 volt power supply is required for this device on self-contained units. Plumbing connections are not required.

The condensate evaporator is located behind the control panel box and is accessible from the rear of the case.

The condensate evaporator can be removed from the case and the condensate drain can be plumbed to a drain to conserve energy if desired. Disconnect the condensate evaporator wires at the condensate evaporator to remove. This must be done by a qualified electrician.

This is an open merchandiser and at times can produce a large amount of condensate water. To ensure that adequate evaporator capacity is available, a high wattage heater is used. The heater turns off automatically when the water level in the pan drops.

Check that the float is positioned correctly and that the switch operates at time of installation.

Make sure that the drain line has not been dislodged during shipment and that the drain trap terminates properly over the water reservoir.

Display Component Check

The display case power switch is located in the control panel on the back of the case. After the case is properly wired to the power source, the switch should be moved to the “on” position to check the case components. The switch should be turned off any time the case is not in operation.

The case is equipped with a top light. The light switch is in the control panel on the back of the case. The switch should be moved to the “on” position to verify that the lights are working properly. The light should be turned off any time the case is not in operation.

The refrigeration system temperature control is in the control panel on the back of the case. The temperature control knob has an “off” position and numbered positions from 1 to 9. The temperature control knob should be moved to a numbered position to verify that the refrigeration system functions properly. The temperature control knob should be in the “off” position when the case is not in use.

Cleaning

For initial setup, clean the case as outlined in the weekly cleaning section.

ELECTRICAL INFORMATION & GROUNDING

This Case Must Be Grounded



DANGER: Improper or faulty hookup of electrical components in the display case can result in severe injury or death.

All case electrical connections must be performed by a licensed electrician.

All electrical wiring hookups must be done in accordance with all applicable local, regional, or national electrical standards.

A separate circuit for each display case is recommended to prevent other appliances on the same circuit from overloading the circuit and causing malfunction.

The electrical service must be grounded upon installation.

This unit is designed for permanent connection to a power source. See the electrical data plate located next to electrical junction box for proper circuit size and wire ampacity.

Self-contained units require two (2) 115 volt power supplies. One power connection supplies voltage to the entire refrigeration and lighting systems. The second power source supplies power to the condensate evaporator assembly.

Remote units require (1) 115 volt power supply because the refrigeration compressor system is wired separately in a remote location.

A 7/8" diameter hole is provided in the back of the case for field wiring connection. An access hole is also provided in the unit base for running power supply up through the floor. See diagram below:

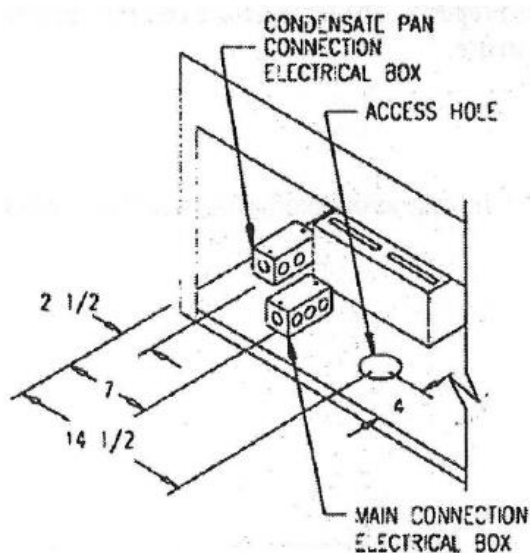

OPERATING INSTRUCTIONS

Initial Start-Up

After all the checks outlined in the installation section of this manual have been made, the case is ready to be put into service.

Series '90 Refrigerated Self-Serve cases are designed to operate at 40 to 42F under maximum ambient conditions of 75F and 55% relative humidity.

Nearly all open refrigerated merchandisers operate better when loaded with product than they do when empty. If a check is made of the case operating temperatures, perform this check with product in the case.

Controls

Light Switch

The light switch controls the power to the lighting circuit. The switch rocker is red in the "on" position, black in the "off" position.

Power Switch

The power switch controls power to the entire case. The switch rocker is red in the "on" position, black in the "off" position.

Temperature Control

This controls the case temperature by cycling the compressor/condensing unit. It has an "off" position and numbered positions 1 through 9. The coldest setting is 9. Set this control at the smallest number while maintaining desired case temperature.

Thermometer

This is a solar powered device. It updates the temperature display approximately every ten seconds.

Placing Product into Case

Do not block the slots along the front of the case display floor or the honeycomb grill in the back of the display area.

CASE SHOULD BE STOCKED WITH PRE-CHILLED PRODUCT ONLY.

The display pans are removable for cleaning and can become dislodged in shipment. To ensure proper air flow and performance of the case, make sure that the display pans are positioned correctly with the side flanges facing down and the front and rear flanges facing up with the taller flange in the front. Check that the pans are installed properly before placing product on the display pans.

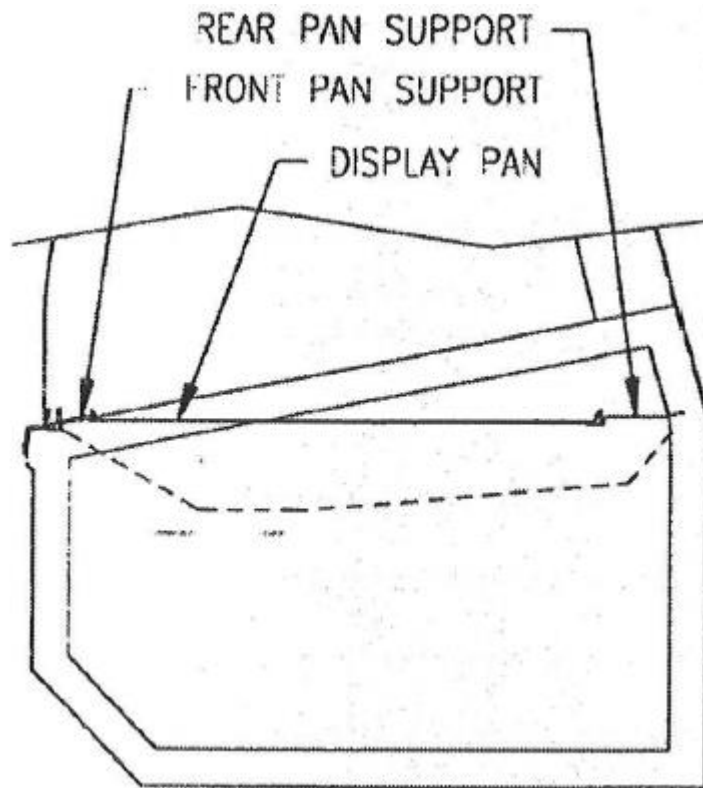

Periodic Maintenance

Cleaning Condenser Coil (Self-Contained Units)

Disconnect power to the unit.

Remove the rear grill and vacuum the front surface of the condenser coil.
This should be done every one to two months as necessary.

CLEANING INSTRUCTIONS

Daily Cleaning

The case should be cleaned thoroughly, as described in the weekly cleaning section, before it is used for the first time.



NOTICE: Avoid splashing or soaking any electrical components with water to prevent electrical damage to the case.



NOTICE: Shut off lights and power switches and remove all product from case. Allow sufficient time for the unit to reach room temperature before proceeding with cleaning.

Note: For major spills or foreign material buildup use complete weekly cleaning instruction.

1. Clean all foreign materials from the door opening.
2. Wipe complete interior of case using a damp cloth.
3. The glass can be cleaned with common window cleaners. The remaining exterior surface should be wiped down using any ammoniated cleansers or warm soapy water.

Note: Detergents are not recommended.

Weekly Cleaning

This procedure is recommended on a weekly basis. It may need to be performed more often if necessary, to maintain a clean, sanitary case. The case should be cleaned to this procedure before using it the first time.



NOTICE: Avoid splashing or soaking any electrical components with water to prevent electrical damage to the case.



NOTICE: Shut off lights and power switches and remove all product from case. Allow sufficient time for the unit to reach room temperature before proceeding with cleaning.

Interior Cleaning

1. Lift the display pans up and take them out of the case.
2. Clean the entire interior of the case using warm soapy water. Wipe off all soapy water with a damp cloth and allow to dry.

Note: Depending on the amount of usage and spillage of foreign material, some fasteners may have to be removed and parts disassembled to allow proper cleaning of the unit.

3. Clean the display pans using warm soapy water and a brush. Rinse thoroughly and allow to dry.
4. Clean both sides of the doors and interior of the front glass using any common window cleaner.
5. Reassemble the case in reverse order start with step 1.

Exterior Cleaning

1. Clean the front glass using any common window cleaner.
2. The exterior surfaces should be wiped down using any ammoniated cleansers or warm soapy water.

Plastic exterior surfaces can be cleaned with any ammoniated household cleaner.

Stains can be removed by scrubbing with TRIAENE Soap, ETHYL CELLOSOLVE, CARBONA, or similar solvent base cleaning fluids. The surfaces must be thoroughly rinsed with water using solvent based cleaners.

SERVICE INFORMATION

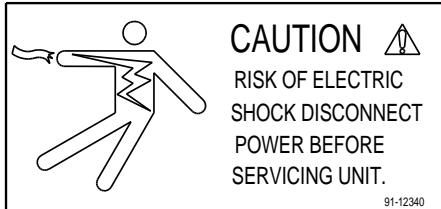

Before any service work is performed on the case, make sure all power is disconnected to the case.

To find a service company in your area, please visit our website at www.federalindustries.com. There you can also find self-service tools to help you get the answers you need faster!

For Warranty Service Requests & ALL Technical Support please contact:

- **Phone:** (800) 356-4206 and choose the Tech Support/Warranty Option
- **Email:** Service@federalind.com

For Warranty Compressors please contact the Parts Department:

- **Phone:** (800) 356-4206 and choose the Warranty Parts Option
- **Email:** Parts@Federalind.com



Federal Industries has partnered with Parts Town for ALL Non-Warranty Part Identification, Pricing, Lead Times, Orders & Freight Quotes. Please contact Parts Town directly if you need parts:

- **Website:** PartsTown.com
- **Email:** CustomerService@PartsTown.com
- **Phone:** 833-809-8188

Pre-Service Checklist

You may avoid the cost and inconvenience of an unnecessary service call by first reviewing this checklist of frequently encountered situations that can cause unsatisfactory case performance.



CAUTION: Before servicing case turn off power at the main breaker of fuse box.

1. Case Does Not Operate

- a. Check for disconnected power supply.
- b. Check for tripped breaker or blown fuse.
- c. Check that the power switch and thermostat are not “off”

2. Lights Do Not Operate

- a. Check that light switch is on.
- b. Be sure light is properly seated in the sockets.
- c. Check that light cords are tight in the sockets.

3. Case Temperature Too Warm

- a. Check that the cold air inlet and outlet slots are not blocked.
- b. Be sure that optional front glass is closed tightly, and optional back doors are closed.
- c. Check for a blocked or dirty condenser coil.
- d. Check that there are no outside air disturbances in or around case. These disturbances can be caused by nearby doors or entrances, overhead ceiling fans, air handling vents, direct sunlight, or other heat sources. The location of open merchandisers is critical to case performance.
- e. Make sure that warm product is not being loaded into case interior. All product must be pre-chilled prior to loading for proper case performance. Warm product can cause excessive compressor run time and frosting and icing of the evaporator coil.
- f. Check cold air flow. Lack of or no air flow inside case may indicate a blocked evaporator coil or defective evaporator fan. Check that paper or foreign material is not blocking the evaporator. If the evaporator coil is blocked due to excessive frost, turn the thermostat knob to the “off” position for approximately one hour with the power switch in the “on” position to defrost.
- g. Check ambient- case is designed to operate in an environment of 75F and 55% relative humidity.
- h. Check case temperature- case is designed to operate between 40F and 42F.

Special Service Situations

There are rare occasions when the refrigerant charge must be evacuated from a case in order to perform service work. In those situations, Federal Industries recommends that the refrigerant charge be evacuated into a recovery system to prevent the possibility of hydrochlorofluorocarbons (HCFC's) from being released into the atmosphere. The release of HCFC's into the atmosphere is a potential source of ozone depletion.

If moisture or liquid is observed around or under a Federal Industries case, an immediate investigation should be made by qualified personnel to determine the source of moisture or liquid. The investigation made should determine if the case is malfunctioning or if there is a simple housekeeping problem.

Moisture or liquid around or under a case is a potential slip/fall hazard for persons walking by or working in the general area of the case. Any case malfunction or housekeeping problem that creates a slip/fall hazard around or under a case should be corrected immediately.

SALE & DISPOSAL

Owner Responsibility

If you sell or give away your Federal Industries case you must make sure that all safety labels and the Installation-Service Manual are included with it. If you need replacement labels or manuals, Federal Industries will provide them free of charge. Contact the customer service department at Federal Industries at (800)356-4206.

The customer service department at Federal Industries should be contacted at the time of sale or disposal of your case so records may be kept of its new location.

If you sell or give away your Federal Industries case and you evacuate the refrigerant charge before shipment, Federal Industries recommends that the charge be evacuated into a recovery system to prevent the possibility of HCFC's from being released into the atmosphere. The release of these HCFC's is a potential source of ozone depletion.

REFRIGERATION & ELECTRICAL DATA

SELF-CONTAINED MODELS

	SN-4CD-SS	SN-6CD-SS	SN-8CD-SS
Refrigerant Charge (R22) before 1/1/00	2 lbs.	3 lbs.	3.5 lbs.
Refrigerant Charge (R134a) before 1/1/2020	1.375 lbs.	1.75 lbs.	2 lbs.
Refrigerant Charge (R513a) after 1/1/2020	1.3125 lbs.	1.6875 lbs.	1.9375 lbs.

ALL MODELS ARE 115 VOLT, 1 PHASE, 60 HERTZ, 2 WIRE

	AMPS	AMPS	AMPS
Compressor			
RLA	8.8	10.1	10.1
LRA	58.8	68.0	68.0
Condenser Fan Motor	0.5	1.4	1.4
Evaporator Fan Motor	0.3	0.3 (2 ea.)	0.3 (2 ea.)
Lights	0.9	0.9	0.9

Refer to the rating plate data attached to the rear of the case for Maximum Fuse Size and Minimum Circuit Ampacity.

REFRIGERATION & ELECTRICAL DATA

REMOTE MODELS (OBSOLETE 1/1/2012)

	SN-4CD-SS-R	SN-6CD-SS-R	SN-8CD-SS-R
Refrigerant Charge before 3/1/01	R22	R22	R22
Refrigerant Charge after 3/1/01	R134a	R134a	R134a

ALL MODELS ARE 115 VOLT, 1 PHASE, 60 HERTZ, 2 WIRE

	AMPS	AMPS	AMPS
Evaporator Fan Motor	0.4	0.8 (2 ea.)	0.8 (2 ea.)
Lights	1.2	1.3	1.7
Condensate Evaporator	10.0	10.0	10.0

Refer to the rating plate data attached to the rear of the case for Maximum Fuse Size and Minimum Circuit Ampacity.

REPLACEMENT PARTS

MODELS: SN-4CD-SS, SN-6CD-SS, & SN-8CD-SS

Part Description	Part Number		
	<u>SN-4CD-SS</u>	<u>SN-6CD-SS</u>	<u>SN-8CD-SS</u>
<u>Refrigeration System</u>			
Condensing Unit (Self-Contained before 5/1/16)	30-14218	30-14219	30-14219
Compressor (Replacement before 5 /1/16)	30-15036	30-15038	30-15038
Condensing Unit (Self-Contained after 5/1/16)	30-20513	30-14219	30-14219
Compressor (Replacement after 5/1/16)	30-20966	30-15038	30-15038
Expansion Valve	32-12625	32-12625	32-15346
Evaporator Coil	33-50053	33-50037	33-11360
Evaporator Fan Motor	41-11628	41-11628	41-11628
Evaporator Fan Blade	72-11450	72-11450	72-11450
Filter Drier	32-12626	32-12391	32-12391
Thermostat	32-15495	32-15495	32-15495
Thermostat Knob	72-15447	72-15447	72-15447
<u>Electrical Components</u>			
Power Switch	41-11066	41-11066	41-11066
Light Switch	41-11066	41-11066	41-11066
Fuse	---	---	41-10713
Terminal Block	45-11056	41-11056	45-11056
Ballast	39-12902	39-12902	39-12902
Light	42-11069	42-11071	42-11069
Light Socket (Stationery)	42-10834	42-10834	42-10834
Light Socket (Spring Loaded)	42-10833	42-10833	42-10833
<u>Condensate Removal</u>			
Condensate Evaporator Assembly (before 3/1/17)	SA-1878	SA-1878	SA-1878
Condensate pump (after 3/1/17)	47-15686	47-15686	47-15686

REPLACEMENT PARTS

MODELS: SN-4CD-SS, SN-6CD-SS, & SN-8CD-SS

Part Description	Part Number		
	<u>SN-4CD-SS</u>	<u>SN-6CD-SS</u>	<u>SN-8CD-SS</u>
<u>Misc. Components</u>			
Lamp Shield	42-30212	42-30212	42-30212
Built-In Front Glass	50-12155	50-11726	50-12155
Leg Leveler	65-11116	65-11116	65-11116
Decal- Electrical Hazard	91-10743	91-10743	91-10743
Decal- Slip Hazard	91-11175	91-11175	91-11175
Countertop	15-11496	15-11497	15-11498
Display Deck	M14697	M14624	M14698-L M14698-R
Honeycomb	W-10492-1	W-10492-2	W-10492-3
Control Panel Cover	15-11469	15-11469	15-11469

WIRING DIAGRAM- MAIN WIRING SELF-CONTAINED

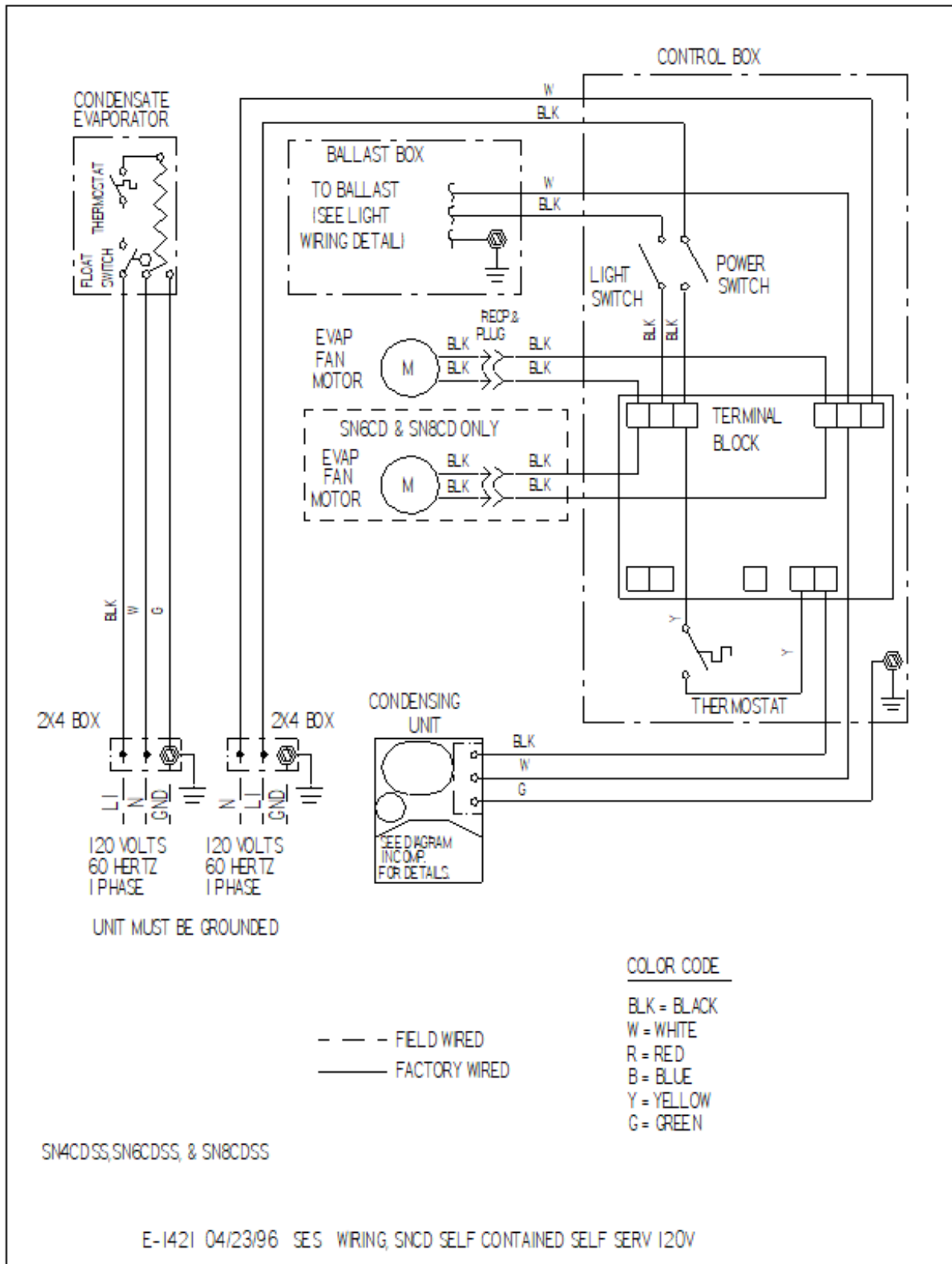

WIRING DIAGRAM- SN4CD-SS & SN6CD-SS

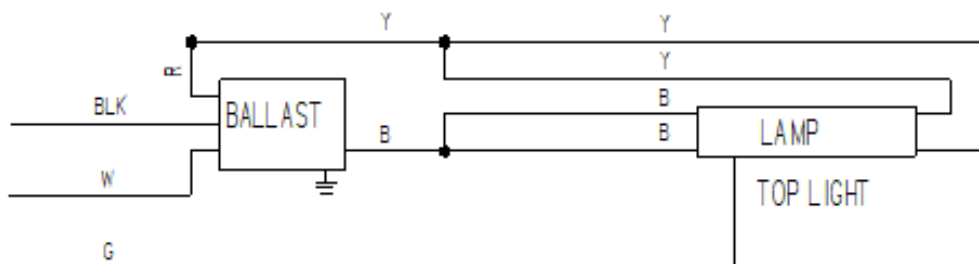

COLOR CODE

BLK = BLACK
W = WHITE
R = RED
B = BLUE
Y = YELLOW
G = GREEN

III F017T8, F025T8, F032T8

E-1322 11/20/95

WIRING DIAGRAM- SN8CD-SS

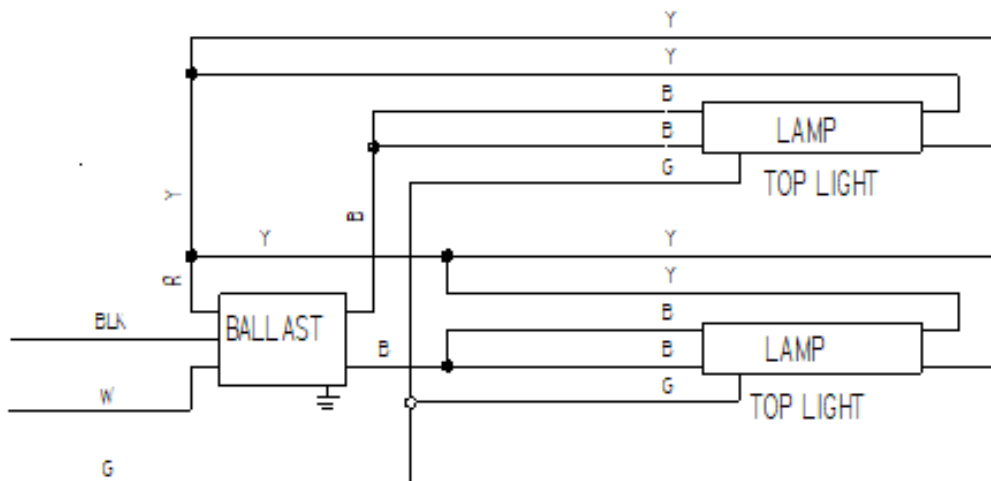

COLOR CODE

BLK = BLACK
W = WHITE
R = RED
B = BLUE
Y = YELLOW
G = GREEN

(2) F017T8, F025T8, F032T8, F040T8
NO PLUG
E-1425 4/23/96

California Residents Only.

 **WARNING**

This product can expose you to chemicals including chromium which is known to the State of California to cause cancer and birth defects or other reproductive harm. For more information go to www.P65Warnings.ca.gov

