

E3981
Rev B 12/21/21



The Signature of Quality®

INSTALLATION & OPERATIONS INSTRUCTIONS
VHSS: Heated Models





CONTENTS

(1)	Introduction	3
1.1	Serial Number.....	3
(2)	Warning Labels & Safety Instructions.....	4
(3)	PRIOR TO UNPACKING EQUIPMENT!.....	5
(4)	General Electrical & Grounding	6
4.1	Cord Connected	6
(5)	Installation Instructions	7
5.1	Locating The Display Case.....	7
5.2	Removing Case From Shipping Skid	7
5.3	Single Case Installation (Stand alone units).....	8
(6)	Joining kit installation (VHSS to VHSS).....	10
6.1	Installation for joined cases (Lineups).....	10
(7)	Feature Overview.....	13
(8)	Shelving Installation and Removal.....	14
8.1	Shelf Brackets and Supports.....	14
(9)	Control Operation.....	17
(10)	Food Packaging Recommendations	19
(11)	Cleaning Instructions	20
11.1	Daily Cleaning	20
11.2	Weekly Cleaning	20
(12)	Service.....	22
(13)	Sale & Disposal	23
13.1	Owner Responsibility	23
(14)	Troubleshooting.....	24
(15)	Wiring Diagrams	25
(16)	VHSS Service Parts	26
(17)	Options	27
17.1	Rear Swinging Door	27
17.2	Rear Sliding Doors	28

(1) Introduction

Thank you for purchasing a Federal Industries display case. This manual contains important instructions for installing and servicing your new display case. A repair parts list and wiring diagram are also included in the manual. Read all of these documents carefully before installing or servicing your case.

	<p>NOTICE</p> <p>Read this manual before installing your case. Keep this manual and refer to it before doing any service on the equipment. Failure to do so could result in personal injury or damage to the case.</p>
	<p>NOTICE</p> <p>Installation and service of the electrical components in the case must be performed by a licensed electrician.</p> <p>The portions of this manual covering components contain technical instructions intended only for persons qualified to perform electrical work.</p>
	<p>DANGER</p> <p>Improper or faulty hookup of electrical components in the case can result in severe injury or death.</p> <p>All electrical wiring hookups must be done in accordance with all applicable local, regional, or national standards.</p>

1.1 SERIAL NUMBER

Record the model and serial numbers of the case for easy reference. Always refer to both model and serial numbers in your correspondence with Federal regarding the case.

Case Model _____ Serial Number _____

This manual cannot cover every installation, use, or service situation. If you need additional information, call or write us:

WARRANTY/TECHNICAL SERVICE DEPARTMENT

Parts Town

1200 Greenbriar Dr.

Addison, IL 60101

Toll Free: (833) 238-8168

Email: techservice@partstown.com



(2) WARNING LABELS & SAFETY INSTRUCTIONS



This is the safety-alert symbol. When you see this symbol on your case or in the manual, be alert to the potential for personal injury or damage to your equipment.

Be sure you understand all safety messages and always follow recommended precautions and safe operating procedures.



NOTICE TO EMPLOYERS:

You must make sure that everyone who installs, uses, or services your case is thoroughly familiar with all safety information and procedures.

Important safety information is presented in this section and throughout the manual. The following signal words are used in the warning and safety messages:

DANGER:	Severe injury or death will occur if you ignore the message.
WARNING:	Severe injury or death can occur if you ignore the message.
CAUTION:	Minor injury or damage to your case can occur if you ignore the message.
NOTICE:	This is important installation, operation, or service information. If you ignore the message, you may damage your case.

The warning and safety labels shown throughout this manual are placed on your Federal Industries case at the factory. Follow all warning label instructions. If any warning or safety labels become lost or damaged, call our customer service department at (800) 356-4206 for replacements.

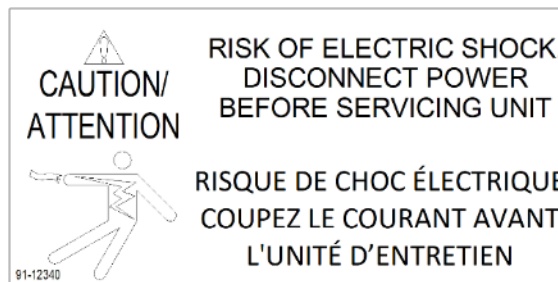

CAUTION: HOT

Located at front of unit and on shelves

(3) PRIOR TO UNPACKING EQUIPMENT!

Inspect for shipping damage.

You are responsible for filing all freight claims with the delivering truck line. Inspect all cartons and crates for damage as soon as they arrive. If damage is noted to shipping crates, cartons, or if a shortage is found, note this on the bill of lading (all copies) prior to signing.

If damage is discovered when the case is uncrated, immediately call the delivering truck line and follow-up the call with a written report indicating concealed damage to your shipment. Ask for an immediate inspection of your concealed damaged item. Crating material must be retained to show the inspector from the truck line.

(4) GENERAL ELECTRICAL & GROUNDING



WARNING:

Improper or faulty hookup of electrical components in the display case can result in severe injury or death.

4.1 CORD CONNECTED

All standard models are supplied with a power cord that is properly sized to the amperage requirements of the case. See the rating plate for specific unit requirements. This can be located as shown in the “FEATURE IDENTIFICATION” section of this manual.

The cord is factory installed protruding from the bottom rear corner of the case.

A separate circuit for each display case is required to prevent other appliances on the same circuit from overloading the circuit and causing malfunction.

MODEL	DIMENSIONS			SHELVING			INTERIOR VOLUME CU FT	STANDARD CONNECTION CORD & PLUG			SHIP WEIGHT
	L	D	H	# OF TIERS	L1	D1		2 WIRE + GROUND		NEMA CORD & PLUG	
	in	in	in		in	in		208-240/60/1			
	mm	mm	mm		mm	mm		AMPS	MAX FUSE SIZE	KILO	
VHSS2460S	24	33	60	3	32.25	16.61	9.07	6.9	15	NEMA 6-15P	310
	610	838	1524		819	422					141
VHSS3660S	36	33	60	3	43.25	16.61	13.98	11.1	15	NEMA 6-15P	355
	914	838	1524		1099	422					161
VHSS4860S	47.25	33	60	3	55.25	16.61	18.48	15.4	20	NEMA 6-20P	490
	1200	838	1524		1403	422					222

MODEL	DIMENSIONS			SHELVING			INTERIOR VOLUME CU FT	STANDARD CONNECTION CORD & PLUG			SHIP WEIGHT
	L	D	H	# OF TIERS	L1	D1		2 WIRE + GROUND		NEMA CORD & PLUG	
	in	in	in		in	in		208-240/60/1			
	mm	mm	mm		mm	mm		AMPS	MAX FUSE SIZE	KILO	
VHSS2478S	24	33	78	4	32.25	16.61	12.64	8.6	15	NEMA 6-15P	510
	610	838	1981		819	422					231
VHSS3678S	36	33	78	4	43.25	16.61	19.47	13.5	20	NEMA 6-20P	555
	914	838	1981		1099	422					252
VHSS4878	47.25	33	78	4	55.25	16.61	25.74			NEMA 6-20P	
	1200	838	1981		1403	422					0



CAUTION

Risk of Electric Shock. If the cord or plug becomes damaged, replace only with a cord and plug of the same type.

(5) INSTALLATION INSTRUCTIONS

5.1 LOCATING THE DISPLAY CASE

The case(s) should be located where it is not subjected to the direct rays of the sun, heating ducts, grills, radiator, or ceiling fans, nor should it be located near open doors or main door entrances. Also, avoid locations where there is excessive air movement or air disturbances and avoid high humidity locations such as near cases with water misting or fogging devices. Failure to locate this case as stated will reduce the performance of your display and will affect temperature of interior of case and product.

5.2 REMOVING CASE FROM SHIPPING SKID

Be sure to leave shelf packaging material intact for this step.

First remove the base front and rear panels

Two or more people should be involved in moving the unit from the pallet onto the ground.

Remove the (4) 1/4" screws that secure the case to the skid. These screws are located in the front and rear corners of the base rails. Base front and rear panels must be removed to access these bolts.

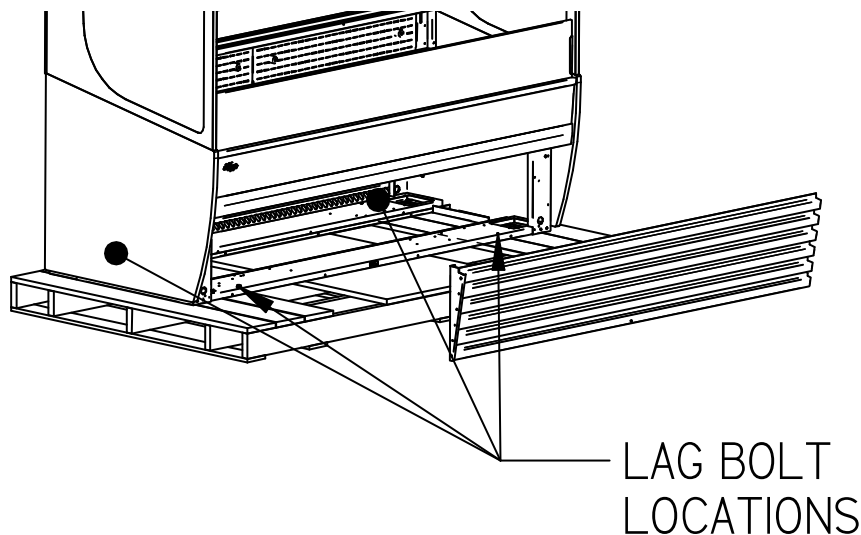

Once all the bolts are removed, slide the unit off the back of the shipping pallet, and tilt it so the rear corner touches the ground. Then have someone move pallet out from under the case and gently tilt the case forward until it touches the floor.

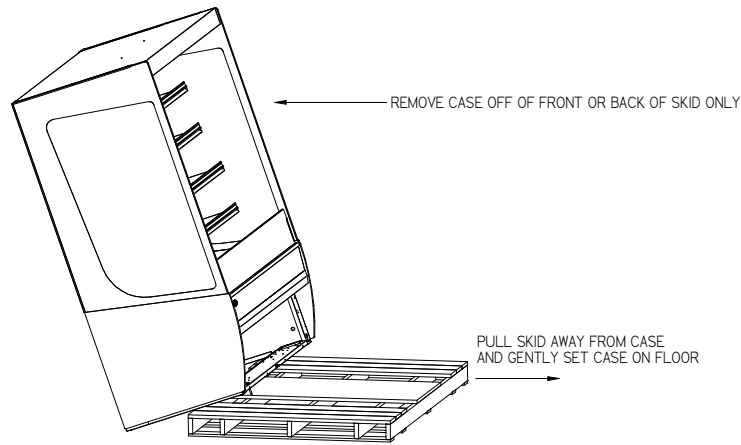

5.2.1 Removing Packaging Material

Remove bubble wrap and packing material for all shelves and panel, brackets, etc. If it is necessary to remove tape residue from plastic materials, use cleaning compounds recommended in the cleaning section of this manual.

5.2.2 Lifting and Moving the Case

	<p>Caution: Do not push or pull against the glass air deflector on front of case. Doing so can cause the glass to break. Do not push or pull on side glass or pull on base panel. Doing so will break glass or pull out panel mounting screws. Care must be taken not to damage the case when removing it from the skid or moving the case.</p>
--	--

5.3 SINGLE CASE INSTALLATION (STAND ALONE UNITS)

Leveling the Case

A wrench is included to aid in adjusting leg levelers.

Check the left-to-right level of the case along front of plastic air deflector retainer.

Check the front-to-rear level of the case along the interior ends of the case.

LEVEL CASE USING THESE SURFACES

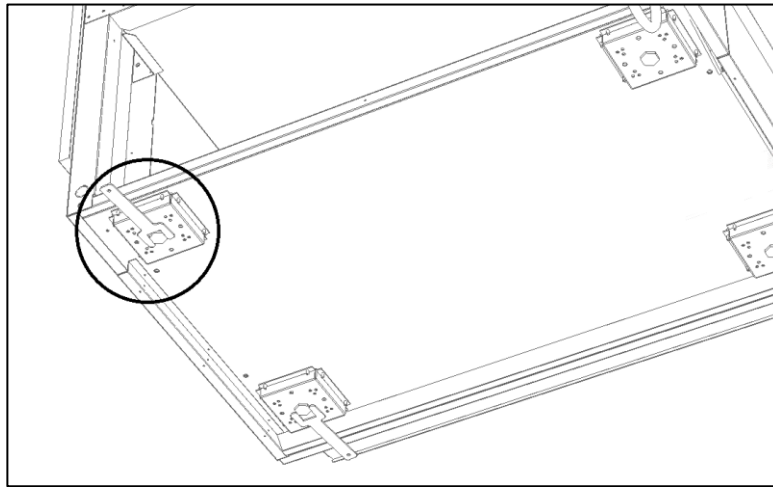
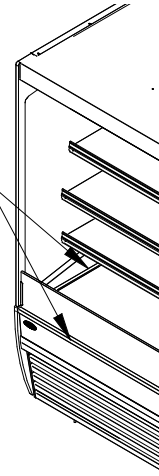

Adjust the (4) outside leg levelers as needed to level the case in each direction.

NOTE: If necessary, use a wood or plastic shim under each leg leveler to avoid scratching the tile floor.

Sealing Unit to The Floor

After the unit is positioned and the leg levelers are turned out, the unit needs to be sealed to the floor for NSF approved installation.

5.4 **PRIOR TO INITIAL USE**

Unit must be cleaned as indicated in the "WEEKLY CLEANING" section of this manual before initial use.

(6) JOINING KIT INSTALLATION (VHSS TO VHSS)

6.1 INSTALLATION FOR JOINED CASES (LINEUPS)

6.1.1 Join heated to heated (VHSS to VHSS)

1. Remove all Shelves, display deck, interior back panel(s), exterior back(s), front and rear base panel, and ceiling.
2. Position the right or left most unit in the desired position for the lineup to start, and level this case.
3. Push the 2nd case next to the 1st and line them up as closely as possible.
4. Adjust the leveling legs of the 2nd case until the units and joining holes align with each other.
5. Using (7) holes noted below, bolt units together with the supplied hardware, and attach joining trim to remove the gap between the decks in the joined units. Re-use the screws in the uprights, as well as the self-drilling screws provided with the kit.

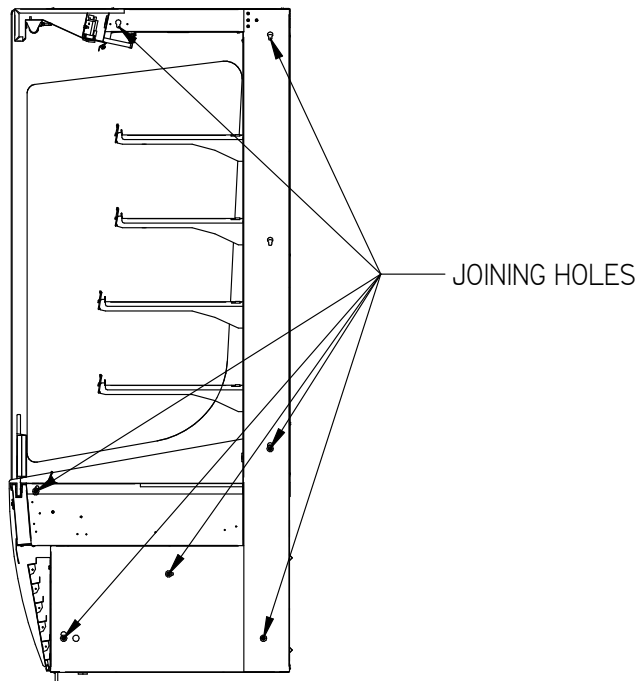

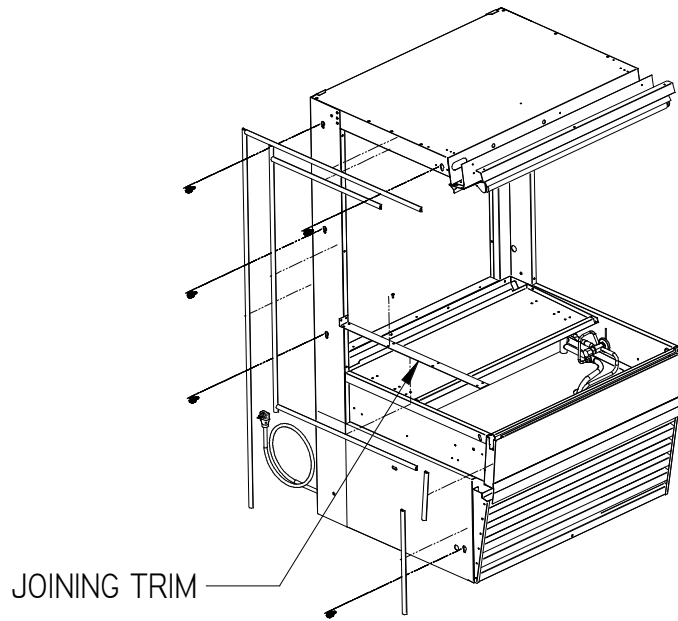

6. Replace all panels that were previously removed.

6.1.2 Join units with glass divider, or join heated to non-refrigerated

For this joining configuration, one unit will come with a lower end panel preinstalled with glass. Five bolt holes will be exposed on the outside of this panel and are the locations that will be used to join the units together. This kit also comes with top and rear exterior trim, but no interior trim.

1. Remove all Shelves, display deck, interior back panel(s), exterior back(s), front and rear base panel, and loosen honeycomb (see cleaning section for honeycomb removal) material on the unfinished end to expose the holes used to bolt units together.
2. Position the right or left most unit in the desired position for the lineup to start, and level this case.
3. Push the 2nd case next to the 1st and line them up as closely as possible.
4. Adjust the leveling legs of the 2nd case until the bolt holes align with the mating holes in the joining case.
5. Push the units together so that the through bolts go through the case to be joined.
6. Using the hardware provided (1/4-20 screw, washer, lock washer), screw the 2nd case with the unfinished end into the first case.

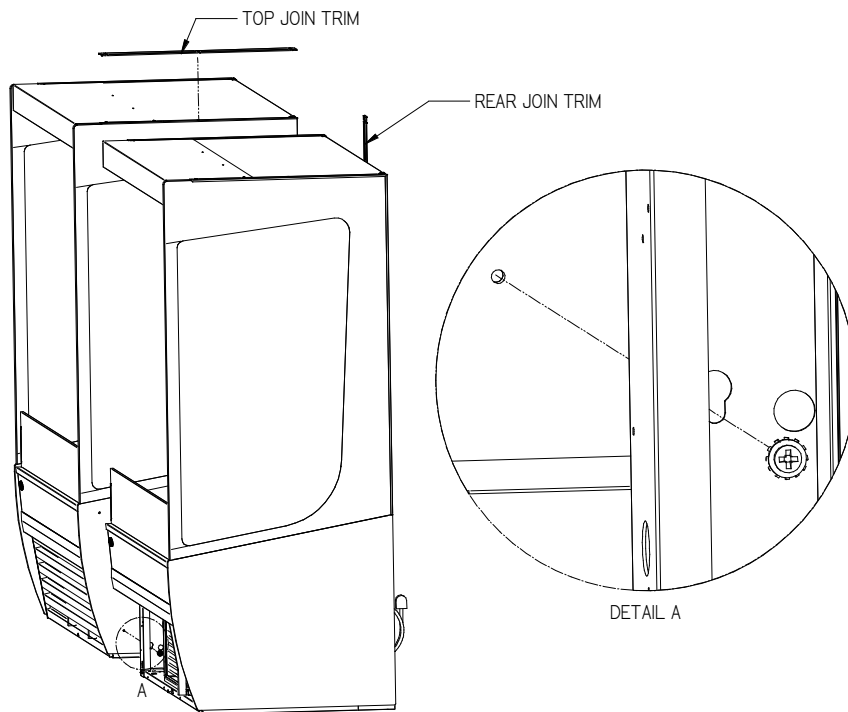

7. Finish the joining process loosening the glass trim on the case to slide the joining trim over the existing trim and secure with the existing fasteners. Do this for both the top trim and the rear trim.

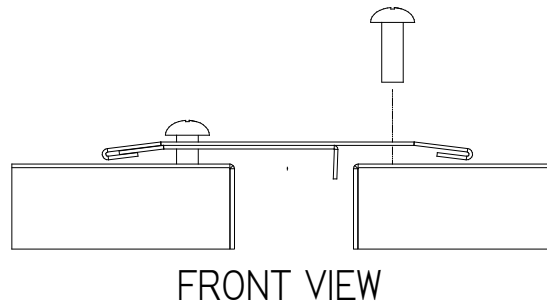

8. Replace any panels previously removed. Units are now joined.

(7) FEATURE OVERVIEW

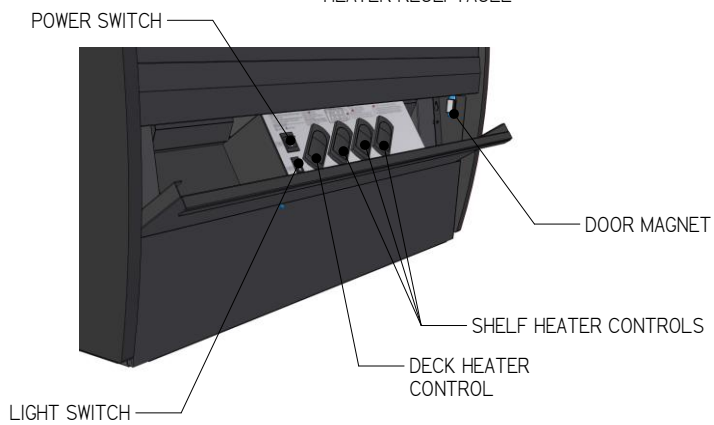
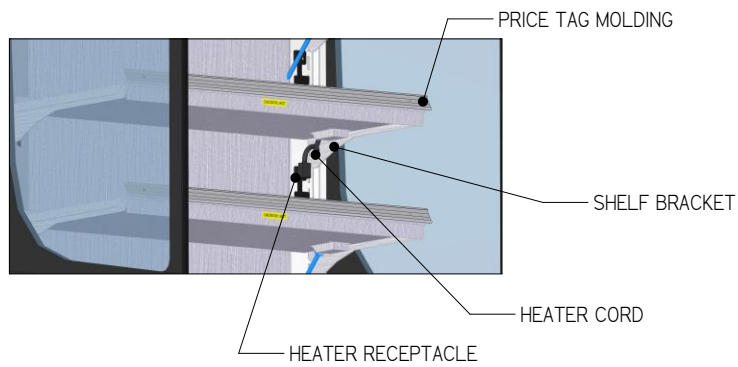
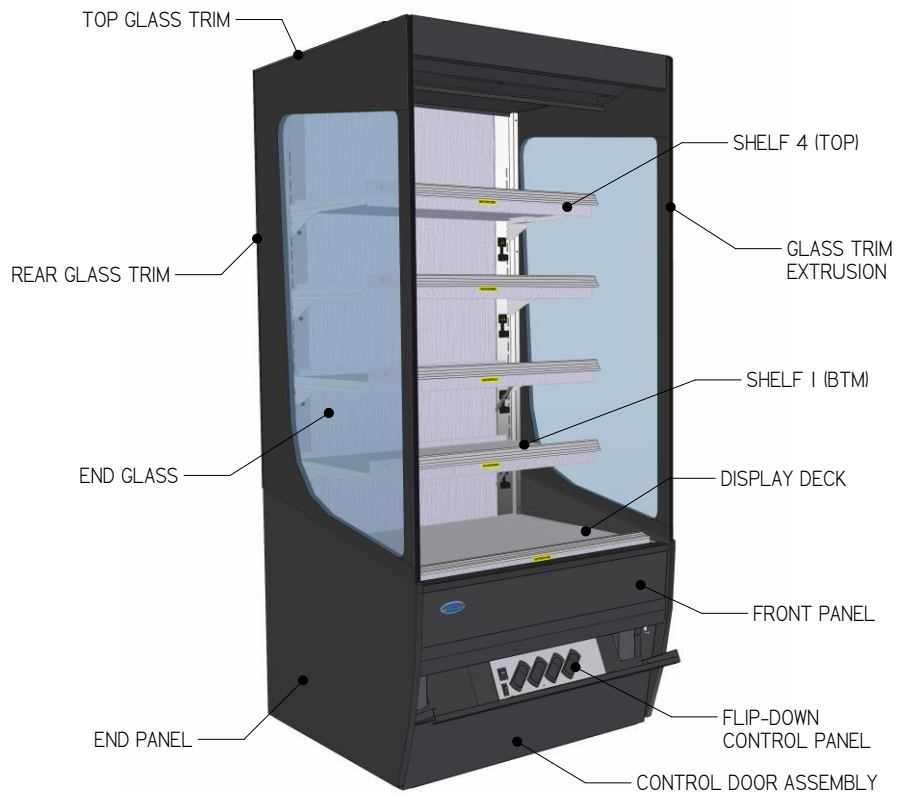

(8) SHELVING INSTALLATION AND REMOVAL

8.1 SHELF BRACKETS AND SUPPORTS

Follow the instructions shown in the diagram below to install shelf brackets. Follow the “LEVEL” path if you want shelves to have no tilt or follow the “SLANTED” path if you want shelves with tilt. Ensure brackets are well seated and face the proper direction.

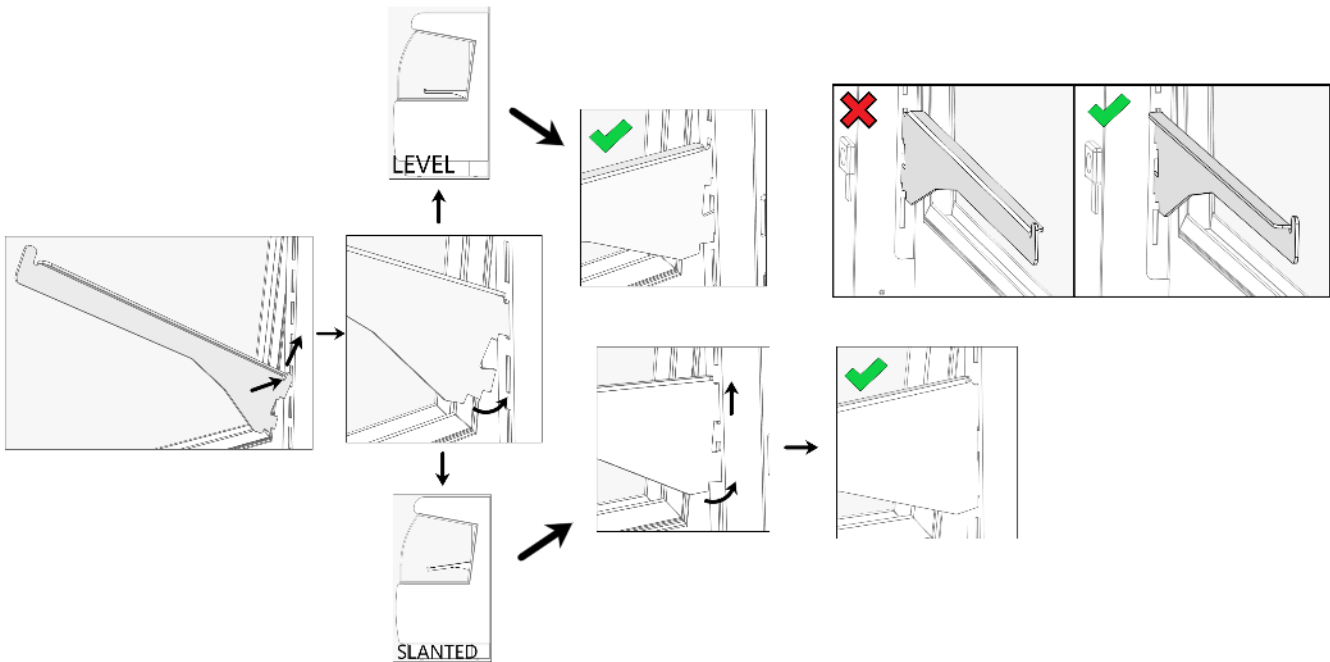

Lay back of shelf across both brackets. Slide it to the rear and then lay the front of the shelf down. Check that the retaining tab of the shelf brackets protrudes through the slot in the shelf.

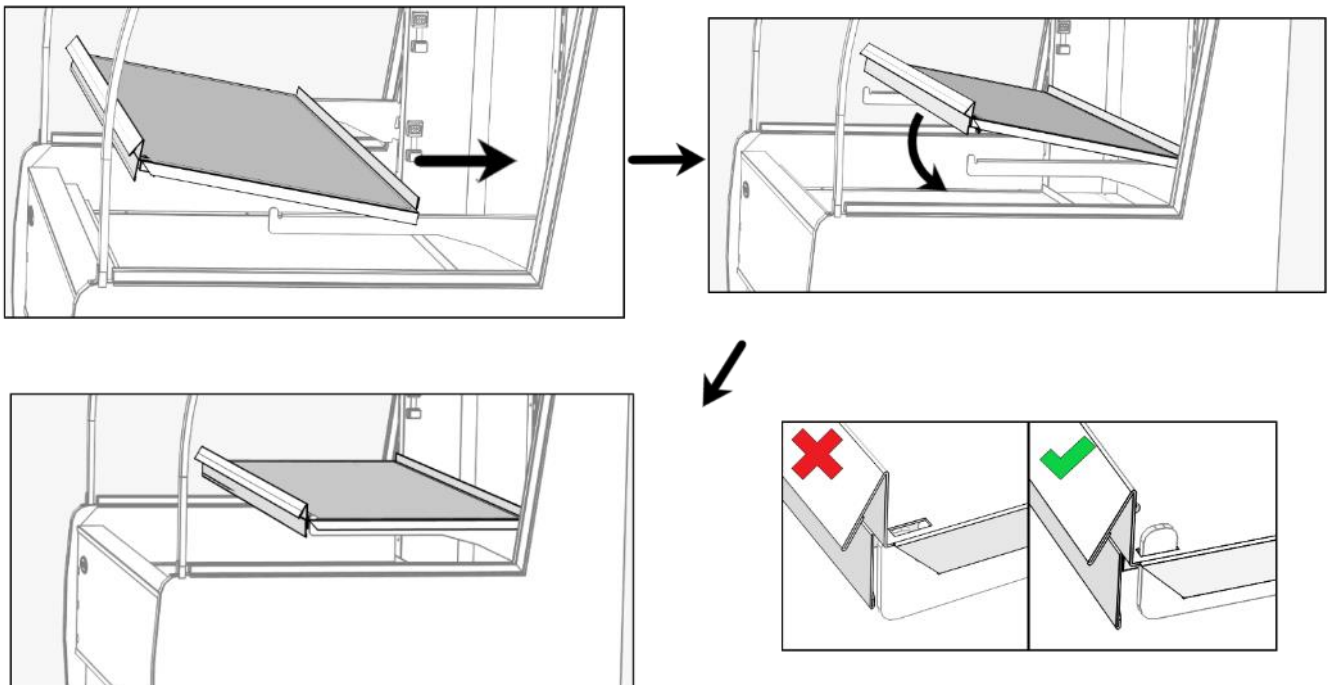

Make the heater connections from the back of the shelf into the receptacle of the vertical frame of the unit. Remove the receptacle cap and push the heater cord (the heater cord comes out of the left side of the shelf) into the nearest heater receptacle. The cord will only insert in one direction as shown below.

Once power is applied to the display case you will be able to check if the cord connection has been adequately made.

Tip: If the rear of the unit is accessible, it may be easier to remove the rear panel and make this connection from the back of the case.

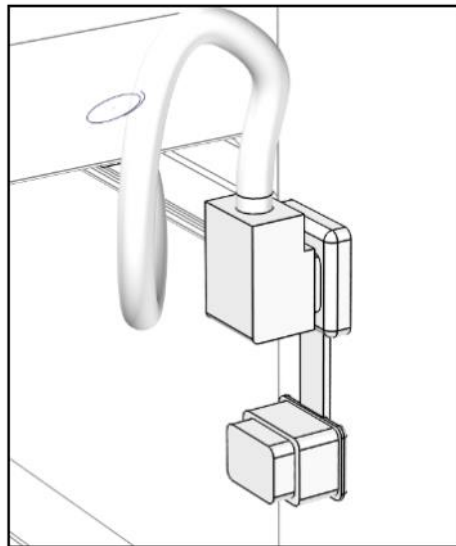
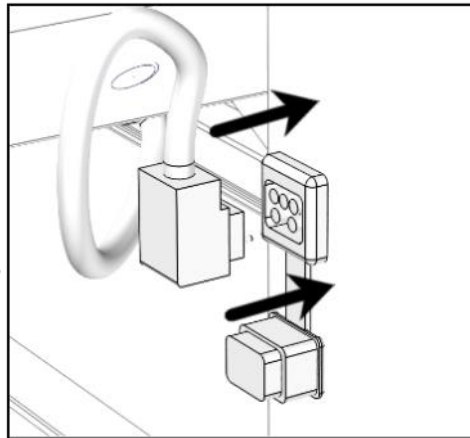

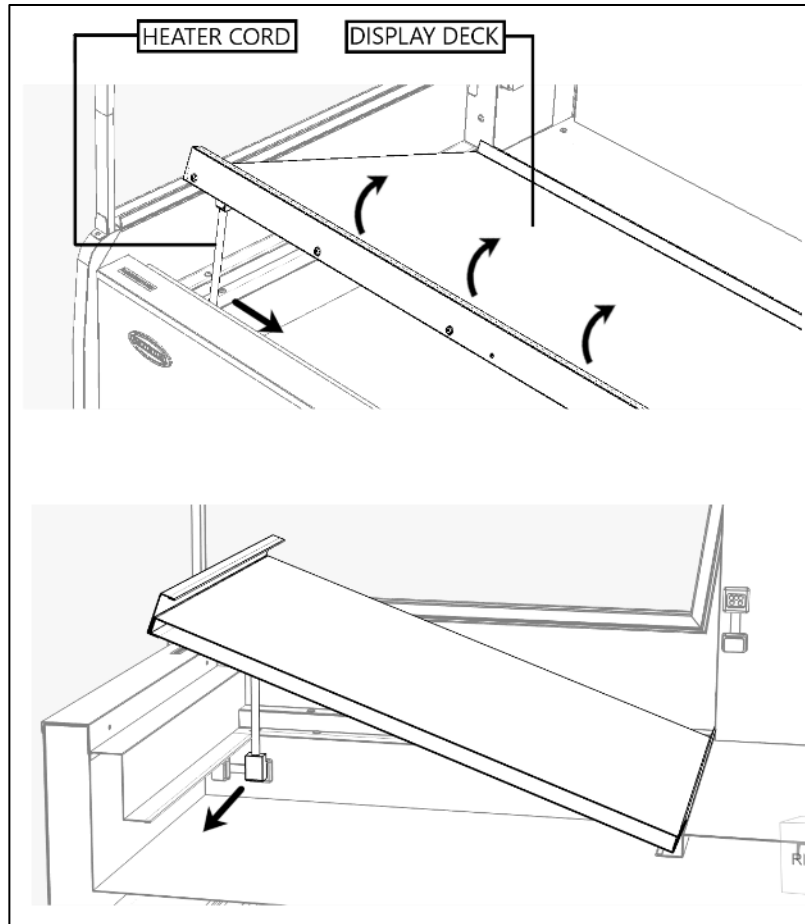

To remove the deck simply lift on the front handle and rotate the front of the deck upward. Hold the assembly in place and use your other hand to disengage the heater cord from the tub. Then simply lift the deck from the unit. Installation is the reverse of removal.

(9) CONTROL OPERATION

▲NOTICE▲

Load items at 170°F or warmer. At time of loading, items stocked in unit **MUST** be pre-heated at 170°F or warmer.

The controls are found behind the front panel pictured below. Pull forward on the short handle of the flip down panel and gently rotate the panel down and let it rest on the toe kick. This exposes the control panel. You now have access to the main power switch, light switch, and the heating controls.

<u>CONTROL</u>	<u>PURPOSE</u>
POWER ON/OFF	POWER ENTIRE UNIT OFF OR ON; TURNS OFF ALL LIGHTS, HEATERS, AND CONTROLS
LIGHTS ON/OFF	TURN ALL LIGHTS ON OR OFF
TOP SHELF	CHANGE SHELF TEMPERATURE SETPOINT AND TURN SHELF ON OR OFF
MIDDLE SHELF 2	
MIDDLE SHELF 1	
BOTTOM SHELF	
DECK	

Use the following procedure to adjust the control setpoints.

ADJUSTMENT

- ▲ Power & setpoint up adjust
- **SET** Set point adjust mode
- ▼ **SET** Set point down adjust

- Power ▲ Hold 3 seconds to start system if off
- Power ▲ Hold 3 seconds to shut down system if on

- Temp Adjust ● **SET** Hold for 3 seconds to enter set point adjust mode
- ▲ Adjusts system to warmer setting while in set point mode
use higher settings for warmer temps - eg. "6" instead of "5"
- ▼ Adjusts system to colder setting while in set point mode
use lower settings for lower temps - eg. "4" instead of "5"

DISPLAY

- Heater on
- Alarm active

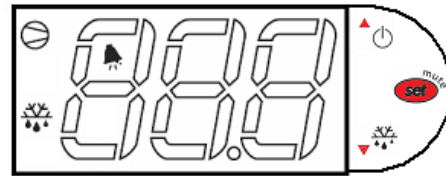

Display Reads:

In normal operation the Display reads control setting
 "OFF" - System is off
 "1" thru "9" - Currently selected set point (system is on)
 "E" followed by any character - Error code see Federal owner's manual
 Some controls display green characters, some display red,
 the control is operating normally in either case.

If control emits beeping noise press and release **SET** to mute
 Read error code and check Federal owner's manual to determine
 if service is required

The temperature controllers each reference one temperature probe that is mounted in the deck or shelf depending on the control. Do not locate the probe to a different position.

Shelf temperature settings are digitally controlled via factory settings 1-9. Setting "1" provides the coolest surface temperatures while setting "9" will provide the warmest.

	Control Setting	Food Recommendations
Coolest	1	Cookies, Pastries, Non-perishables
	2	
	3	
	4	
Warmest	5	Sandwiches
	6	
	7	
	8	Rotisserie Chicken, Pizza, Fries
	9	

(10) FOOD PACKAGING RECOMMENDATIONS





This merchandiser is designed to be used with pre-packaged product only. All food items placed in the merchandiser must be packaged. No foods should be placed in the merchandiser without packaging.

▲NOTICE▲

Load items at 170°F or warmer. At time of loading, items stocked in unit MUST be pre-heated at 170°F or warmer.

Not all packaging is compatible with this merchandiser. Any packaging material with a rating of less than 250°F should not be used.

Typically, polypropylene (recycle code 5) works well, but check with the manufacturer first to get an accurate assessment of the application.





 <u>DO NOT USE</u> the following packaging materials:	
Recycle Code	Material Name
	Polyethylene terephthalate
	High-density polyethylene
	Polyvinyl chloride
	Low-density polyethylene

Materials listed in the table above will not survive the high temperature conditions of this merchandiser.

(11) CLEANING INSTRUCTIONS

11.1 DAILY CLEANING

The case should be cleaned thoroughly, as described in the weekly cleaning section before it is used for the first time.

	NOTICE: Avoid splashing or soaking any electrical components with water to prevent electrical damage to the case.
	NOTICE: Shut off power switch and remove all product from case. Allow enough time for the unit to reach room temperature before proceeding with cleaning.
	NOTICE: Remove all product from case before proceeding with cleaning procedure.
	NOTICE: This case is not designed to be cleaned by flushing.

Note: For major spills or foreign material buildup perform the weekly cleaning instructions.



Note: Detergents are not recommended and do not use abrasive cleaners or pads to prevent scratching of surfaces.

1. Clean all foreign materials from the door opening.
1. Wipe complete interior of both the upper & lower areas of case using a damp cloth.
2. The remaining exterior surface should be wiped down using any ammoniated cleaners or soapy warm water.

11.2 WEEKLY CLEANING

This procedure is recommended on a weekly basis. It may need to be performed more often if necessary, to maintain a clean, sanitary case. The case should be cleaned to this procedure before using the first time.

	NOTICE: Avoid splashing or soaking any electrical components with water to prevent electrical damage to the case.
---	---

	<p>NOTICE: Shut off power switches and remove all product from case. Allow enough time for the unit to reach room temperature before proceeding with cleaning.</p>
	<p>NOTICE: Remove all product from case before proceeding with cleaning procedure.</p>
	<p>NOTICE: This case is not designed to be cleaned by flushing.</p>

1. Side, and rear door glass can be cleaned with common window cleaners.
2. Remove interior shelving and display deck from unit as described in the “Shelving Installation and Removal” section of this manual.
3. Clean all shelves, shelf supports, shelf light deflectors, shelf brackets, shelf standards using warm soapy water and a brush. Rinse thoroughly and allow to dry.
4. Remove the display deck and clean using warm soapy water and a brush. Rinse thoroughly and allow to dry.
5. Clean the entire interior of the case using warm soapy water. Wipe off all soapy water with a damp cloth and allow to dry. (DO NOT use solvents such as Acetone, Benzene, Carbon Tetrachloride, and Lacquer Thinners)
6. Reassemble all components in reverse order.
7. The exterior surfaces should be wiped down using any ammoniated cleansers or warm soapy water.

(12) SERVICE

Service Information

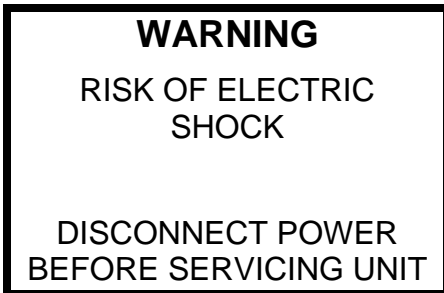

Before any service work is performed on the case, make sure all power is disconnected to the case.

To find a service company in your area, please visit our website at <https://federalind.com/support-service/service-rep-locator>. There you can also find self-service tools to help you get the answers you need faster!

For warranty service requests and all technical support, including compressors and other service parts please contact:

- Phone: (833) 238-8168
- Email: techservice@partstown.com



Federal Industries has partnered with Parts Town for ALL Non-Warranty Part Identification, Pricing, Lead Times, Orders & Freight Quotes. Please contact Parts Town directly if you need parts:

- Website: Partstown.com
- Email: CustomerService@Partstown.com
- Phone: 833-809-8188

(13) SALE & DISPOSAL

13.1 OWNER RESPONSIBILITY

If you sell or give away your Federal Industries case you must make sure that all safety labels and the Installation-Service Manual are included with it. If you need replacement labels or manuals, Federal Industries will provide them free of charge. Contact the customer service department at Federal Industries at (800) 356-4206.

The customer service department at Federal Industries should be contacted at the time of sale or disposal of your case so records may be kept of its new location.

(14) TROUBLESHOOTING

Pre-Service Checklist

You may avoid the cost and inconvenience of an unnecessary service call by first reviewing this checklist of frequently encountered situations that can cause unsatisfactory case performance.

Case Does Not Operate

Check for disconnected power supply.

Check for tripped breaker on blown fuse.

Check that the thermostat display is on and is not displaying an error.

Lights Do Not Operate

Check that light switch is on.

Check for tripped breaker or blown fuse.

Check that light cords are plugged in correctly to sockets. Check connector on LED light, and connector on

Temperature is too low

Increase control setpoint

Check supply voltage to case is above 208V

Look for HVAC discharge vents, fans, and other possible air disruptions.

If using rack, check rack orientation. Flip rack over if needed so product is closer to the shelf surface.

Temperature is too high

Turn down control setpoint

Check the control for errors and contact service

Use supplied food rack to reduce heat intensity on food

Control Error

Turn the main power switch to off to power down the unit

Wait 10s, and power the unit back on

If error is still present, ensure all heater cords are seated fully into their receptacles.

(15) WIRING DIAGRAMS

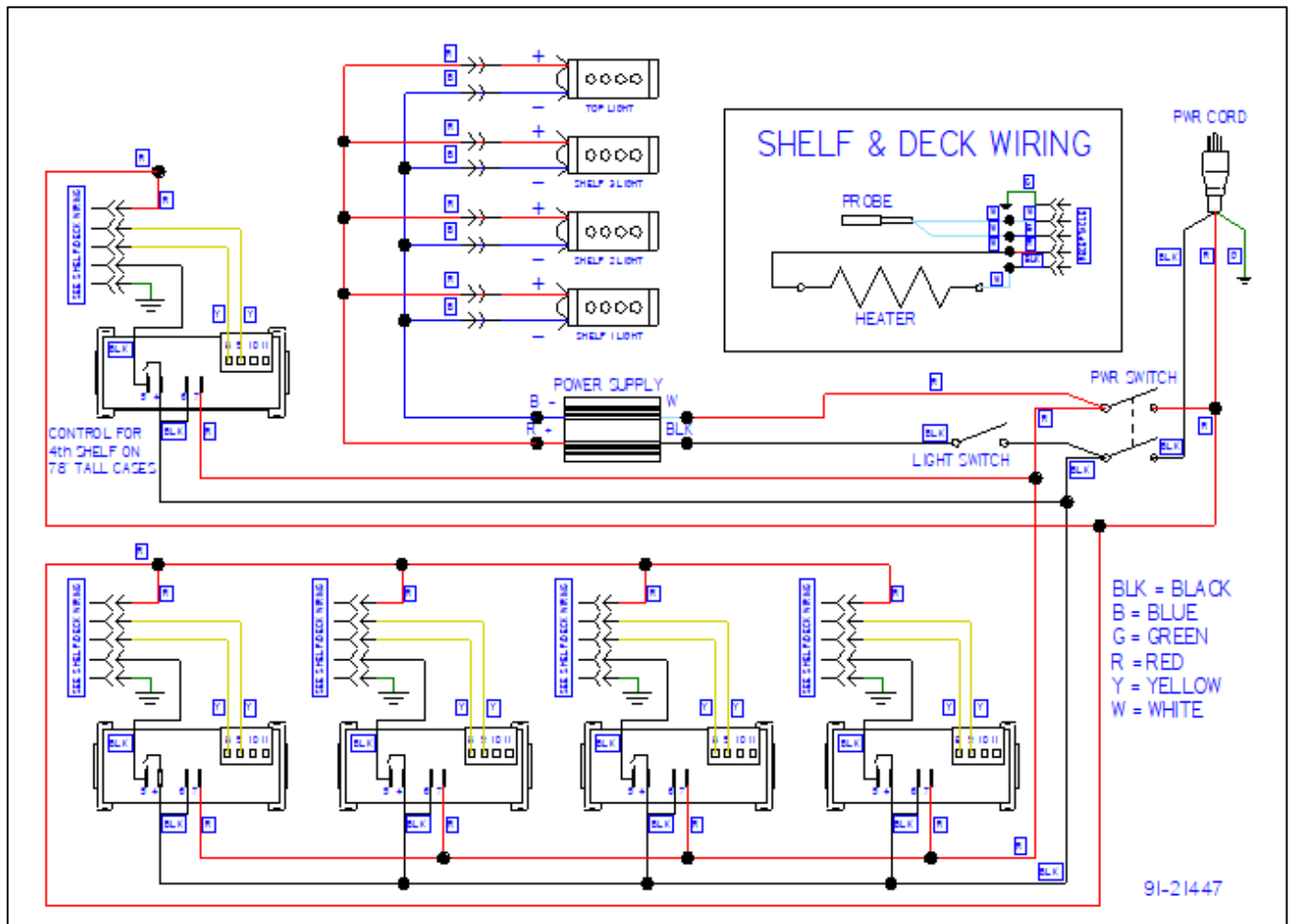

(16) VHSS SERVICE PARTS

Heated Shelves and Deck					
Model	Shelf Part#	Deck Part#	LEFT SHELF BRACKET	RIGHT SHELF BRACKET	CAUTION HOT STICKER
VHSS2460	SA6035-S	SA6041-S	67-21204-L	67-21204-R	91-10207
VHSS3660	SA6035-1S	SA6041-1S	67-21204-L	67-21204-R	91-10207
VHSS4860	SA6035-2S	SA6041-2S	67-21204-L	67-21204-R	91-10207
VHSS2478	SA6035-S	SA6041-S	67-21204-L	67-21204-R	91-10207
VHSS3678	SA6035-1S	SA6041-1S	67-21204-L	67-21204-R	91-10207

ELECTRICAL									
Model	TEMPERATURE CONTROLS	POWER SWITCH	LIGHT SWITCH	LED POWER SUPPLY	POWER CORD	WIRE HARNESS, CONTROL	WIRE HARNESS, HEATER	HARNESS, LIGHTS	RECEPTACLE, HEATER
VHSS2460	32-19865-16	41-18186	41-11066	39-20986	43-17839	43-21093	43-21098	43-21009	43-21100
VHSS3660	32-19865-16	41-18186	41-11066	39-20986	43-17839	43-21093	43-21098	43-21009	43-21100
VHSS4860	32-19865-16	41-18186	41-11066	39-20986	43-19090	43-21093	43-21098	43-21009	43-21100
VHSS2478	32-19865-16	41-18186	41-11066	39-20986	43-17839	43-21093	43-21098	43-21009	43-21100
VHSS3678	32-19865-16	41-18186	41-11066	39-20986	43-19090	43-21093	43-21098	43-21009	43-21100

CONTROL PANEL ASSEMBLY (SEE ELECTRICAL FOR CONTROLS)					
Model	INSTRUCTION DECAL	DOOR MAGNET	HINGE RIVET	HINGE BUSHING	PLASTIC RIVET
ALL VHSS	91-21417	56-17636	77-12280	81-21489	77-21488

STANDARD ENDS AND GLASS		
Model	STANDARD END LEFT/RIGHT	STANDARD END GLASS
VHSS ALL	68-21300-1LB/1RB	50-21330-2B

LED LIGHTS						
Model	TOP LIGHT	SHELF LIGHT	LED LIGHT CORDS, SHELF	LED LIGHT CORDS, TOP LIGHT	LED MOUNTING CLIP	SHELF LIGHT CORD CLIP
VHSS2460	42-20871-20C35	42-20871-18C35	43-21333	43-20862-1B	67-20869-30	67-20952
VHSS3660	42-20871-30C35	42-20871-25C35	43-21333	43-20862-1B	67-20869-30	67-20952
VHSS4860	42-20871-42C35	42-20871-38C35	43-21333	43-20862-1B	67-20869-30	67-20952
VHSS2478	42-20871-20C35	42-20871-18C35	43-21333	43-20862-1B	67-20869-30	67-20952
VHSS3678	42-20871-30C35	42-20871-25C35	43-21333	43-20862-1B	67-20869-30	67-20952

(17) OPTIONS

17.1 REAR SWINGING DOOR

828/829-9640-INTB BLACK INTERIOR PARTS REAR SWING DOOR VHSS/VNSS2460/2478							
ITEM	PART #	QTY	PART #	QTY	BILL. DESIG.	COLOR DESIG.	DESCRIPTION
	828-9640 VHSS2460		828-9640 VHSS2460		829-9640 VHSS2478		
4	75-11483	12	75-11483	12	INT	B	SCREW8-18X.5PH TRTEK2.410SS
11	M21576-1ILB	1	M21576-1LB	1	INT	B	LINERDOOR SIDE
12	M21576-1IRB	1	M21576-1RB	1	INT	B	LINERDOOR SIDE
13	M21577-5B	1	M21577-5B	1	INT	B	LINERDOOR TOP
14	M21577-B	1	M21577-B	1	INT	B	LINERDOOR BOTTOM

828/829-9640-INTW WHITE INTERIOR PARTS REAR SWING DOOR VHSS/VNSS2460/2478							
ITEM	PART #	QTY	PART #	QTY	BILL. DESIG.	COLOR DESIG.	DESCRIPTION
	828-9640 VHSS2460		828-9640 VHSS2460		829-9640 VHSS2478		
4	75-11483	12	75-11483	12	INT	W	SCREW8-18X.5PH TRTEK2.410SS
11	M21576-1ILW	1	M21576-1LW	1	INT	W	LINERDOOR SIDE
12	M21576-1IRW	1	M21576-1RW	1	INT	W	LINERDOOR SIDE
13	M21577-5W	1	M21577-5W	1	INT	W	LINERDOOR TOP
14	M21577-W	1	M21577-W	1	INT	W	LINERDOOR BOTTOM

828/829-9640-INTS S/S INTERIOR PARTS REAR SWING DOOR VHSS/VNSS2460/2478							
ITEM	PART #	QTY	PART #	QTY	BILL. DESIG.	COLOR DESIG.	DESCRIPTION
	828-9640 VHSS2460		828-9640 VHSS2460		829-9640 VHSS2478		
4	75-11483	12	75-11483	12	INT	S	SCREW8-18X.5PH TRTEK2.410SS
11	M21576-1ILS	1	M21576-1LS	1	INT	S	LINERDOOR SIDE
12	M21576-1IRS	1	M21576-1RS	1	INT	S	LINERDOOR SIDE
13	M21577-5S	1	M21577-5S	1	INT	S	LINERDOOR TOP
14	M21577-S	1	M21577-S	1	INT	S	LINERDOOR BOTTOM

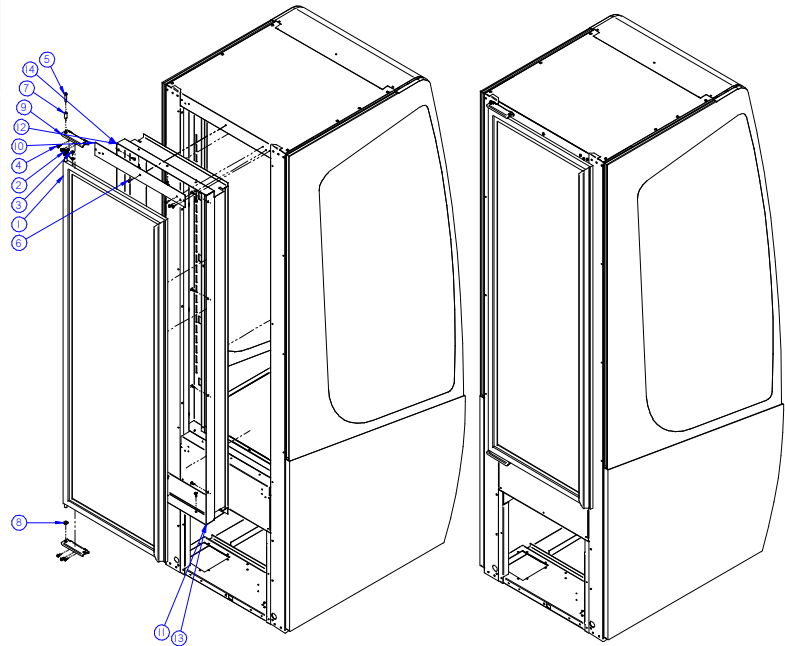

17.2 REAR SLIDING DOORS

INTERIOR PARTS VHSS/VNSS SLIDING REAR DOORS BLACK																	
ITEM	PART #	QTY	PART #	QTY	PART #	QTY	PART #	QTY	PART #	QTY	PART #	QTY	PART #	QTY	BILL DESIG.	COLOR DESIG.	DESCRIPTION
	830-9630 VHSS/VNSS3660		831-9630 VHSS/VNSS3678		832-9630 VHSS/VNSS4860		823-9630 VNSS4878		824-9630 VNSS6060		825-9630 VNSS6078		826-9630 VNSS7260		827-9630 VNSS7260		
5	75-11483	11	75-11483	11	75-11483	11	75-11483	11	75-11483	11	75-11483	11	75-11483	11	INT	B	SCREW 8-18X.5 PH TR, TEK 2.410SS
6	75-12732	3	75-12732	3	75-12732	3	75-12732	3	75-12732	3	75-12732	3	75-12732	3	INT	B	SCREW 10-16X1/2 TK2 PH PN BK
7	M21576-1ILB	1	M21576-1LB	1	M21576-1ILB	1	M21576-1LB	1	M21576-1ILB	1	M21576-1LB	1	M21576-1ILB	1	INT	B	LINER DOOR SIDE
8	M21576-1IRB	1	M21576-1RB	1	M21576-1IRB	1	M21576-1RB	1	M21576-1IRB	1	M21576-1RB	1	M21576-1IRB	1	INT	B	LINER DOOR SIDE
9	M21577-1B	1	M21577-1B	1	M21577-2B	1	M21577-2B	1	M21577-3B	1	M21577-3B	1	M21577-4B	1	INT	B	LINER DOOR BOTTOM
10	M21577-5B	1	M21577-5B	1	M21577-6B	1	M21577-6B	1	M21577-7B	1	M21577-7B	1	M21577-8B	1	INT	B	LINER DOOR TOP

INTERIOR PARTS VHSS/VNSS SLIDING REAR DOORS WHITE																	
ITEM	PART #	QTY	PART #	QTY	PART #	QTY	PART #	QTY	PART #	QTY	PART #	QTY	PART #	QTY	BILL DESIG.	COLOR DESIG.	DESCRIPTION
	830-9630 VHSS/VNSS3660		831-9630 VHSS/VNSS3678		832-9630 VHSS/VNSS4860		823-9630 VNSS4878		824-9630 VNSS6060		825-9630 VNSS6078		826-9630 VNSS7260		827-9630 VNSS7260		
5	75-11483	11	75-11483	11	75-11483	11	75-11483	11	75-11483	11	75-11483	11	75-11483	11	INT	W	SCREW 8-18X.5 PH TR, TEK 2.410SS
6	75-12732	3	75-12732	3	75-12732	3	75-12732	3	75-12732	3	75-12732	3	75-12732	3	INT	W	SCREW 10-16X1/2 TK2 PH PN BK
7	M21576-1ILW	1	M21576-1LW	1	M21576-1ILW	1	M21576-1LW	1	M21576-1ILW	1	M21576-1LW	1	M21576-1ILW	1	INT	W	LINER DOOR SIDE
8	M21576-1IRW	1	M21576-1RW	1	M21576-1IRW	1	M21576-1RW	1	M21576-1IRW	1	M21576-1RW	1	M21576-1IRW	1	INT	W	LINER DOOR SIDE
9	M21577-1W	1	M21577-1W	1	M21577-2W	1	M21577-2W	1	M21577-3W	1	M21577-3W	1	M21577-4W	1	INT	W	LINER DOOR BOTTOM
10	M21577-5W	1	M21577-5W	1	M21577-6W	1	M21577-6W	1	M21577-7W	1	M21577-7W	1	M21577-8W	1	INT	W	LINER DOOR TOP

INTERIOR PARTS VHSS/VNSS SLIDING REAR DOORS S/S																	
ITEM	PART #	QTY	PART #	QTY	PART #	QTY	PART #	QTY	PART #	QTY	PART #	QTY	PART #	QTY	BILL DESIG.	COLOR DESIG.	DESCRIPTION
	830-9630 VHSS/VNSS3660		831-9630 VHSS/VNSS3678		832-9630 VHSS/VNSS4860		823-9630 VNSS4878		824-9630 VNSS6060		825-9630 VNSS6078		826-9630 VNSS7260		827-9630 VNSS7260		
5	75-11483	11	75-11483	11	75-11483	11	75-11483	11	75-11483	11	75-11483	11	75-11483	11	INT	S	SCREW 8-18X.5 PH TR, TEK 2.410SS
6	75-12732	3	75-12732	3	75-12732	3	75-12732	3	75-12732	3	75-12732	3	75-12732	3	INT	S	SCREW 10-16X1/2 TK2 PH PN BK
7	M21576-1ILS	1	M21576-1LS	1	M21576-1ILS	1	M21576-1LS	1	M21576-1ILS	1	M21576-1LS	1	M21576-1ILS	1	INT	S	LINER DOOR SIDE
8	M21576-1IRS	1	M21576-1RS	1	M21576-1IRS	1	M21576-1RS	1	M21576-1IRS	1	M21576-1RS	1	M21576-1IRS	1	INT	S	LINER DOOR SIDE
9	M21577-1S	1	M21577-1S	1	M21577-2S	1	M21577-2S	1	M21577-3S	1	M21577-3S	1	M21577-4S	1	INT	S	LINER DOOR BOTTOM
10	M21577-5S	1	M21577-5S	1	M21577-6S	1	M21577-6S	1	M21577-7S	1	M21577-7S	1	M21577-8S	1	INT	S	LINER DOOR TOP

